

SECTION D-D

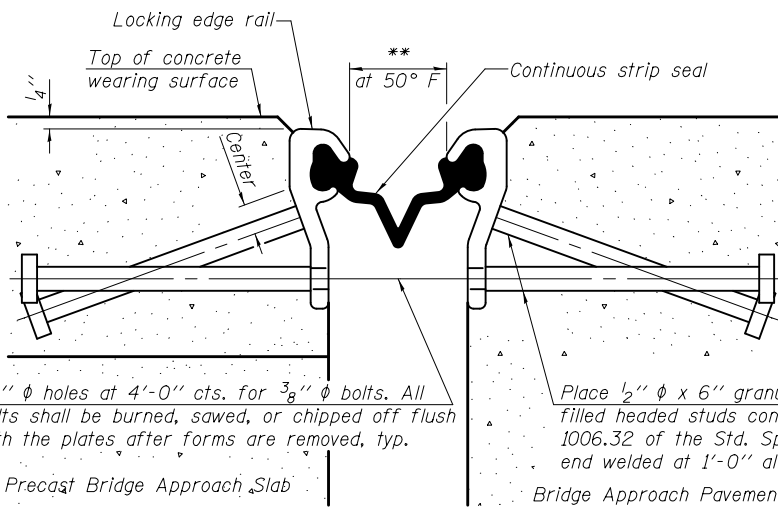

SECTION THRU STRIP SEAL JOINT
(at rt. angles)

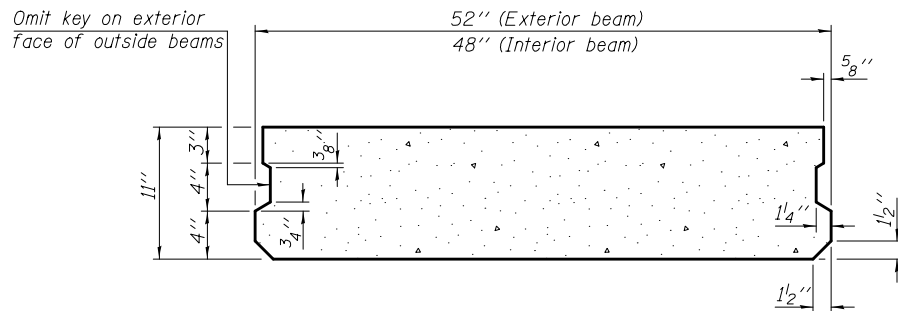

SECTION E-E
(Showing dimensions)

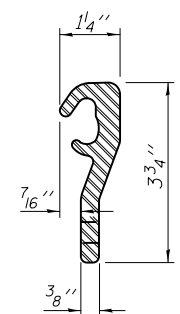

ROLLED (EXTRUDED) RAIL

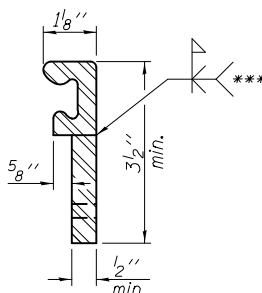

WELDED RAIL

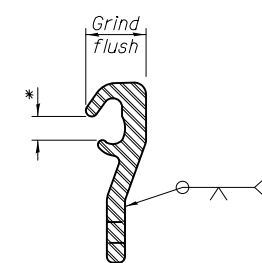

LOCKING EDGE RAIL SPLICE

Rolled rail shown, welded rail similar.

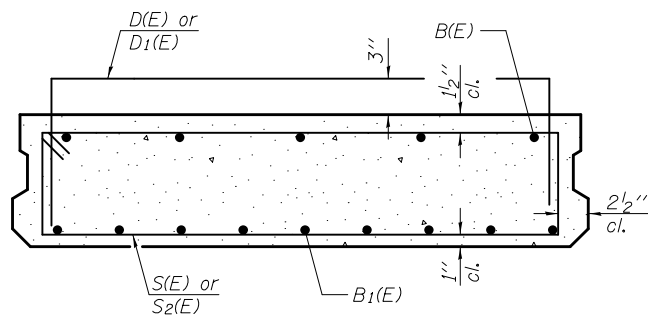

SECTION E-E
(Showing reinforcement)

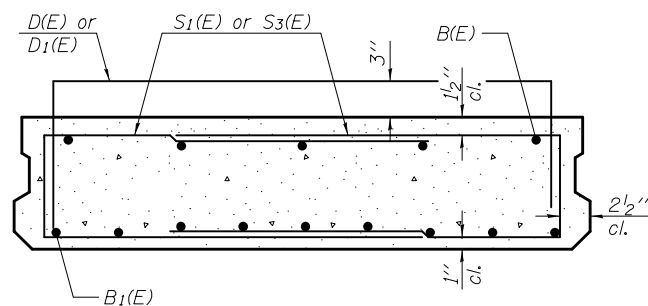

VIEW F-F
(Showing reinforcement)

*Omit weld at seal opening.
 **The joint opening shall be determined per Article 520.04 except that on jointless structures, the distance described as the bridge length between the nearest fixed bearings each way from the joint shall be taken as half the bridge length plus the approach slab length. The minimum dimension shall be 1 1/2" for installation purposes.
 ***Back gouge not required if complete joint penetration is verified by mock-up.

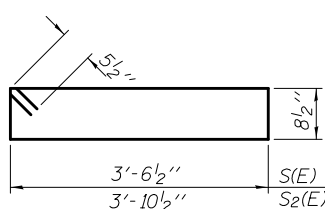

BARS S(E) & S2(E)

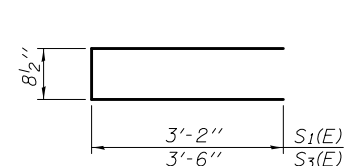

BARS S1(E) & S3(E)

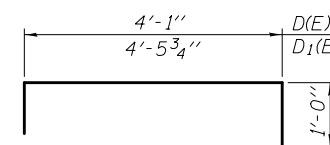

BARS D(E) & D1(E)

BAR LIST EACH INTERIOR BEAM
(For information only)

| Bar | No. | Size | Length | Shape |
|-------|-----|------|--------|-------|
| B(E) | 5 | #5 | 29'-8" | — |
| B1(E) | 9 | #9 | 29'-8" | — |
| D(E) | 22 | #4 | 6'-1" | □ |
| S(E) | 58 | #5 | 9'-5" | ▬ |
| S1(E) | 14 | #5 | 7'-1" | ▬ |

BAR LIST EACH EXTERIOR BEAM
(For information only)

| Bar | No. | Size | Length | Shape |
|-------|-----|------|--------|-------|
| B(E) | 5 | #5 | 29'-8" | — |
| B1(E) | 10 | #9 | 29'-8" | — |
| D1(E) | 31 | #4 | 6'-6" | □ |
| S2(E) | 58 | #5 | 10'-1" | ▬ |
| S3(E) | 14 | #5 | 7'-9" | ▬ |

Notes:

The precast bridge approach slab shall be according to Section 504 of the Standard Specifications and shall be paid for at the contract unit price per square foot for Precast Bridge Approach Slab.
 Cast-in-place substitution of Precast Bridge Approach Slab is not allowed.
 Parapet concrete shall be paid for as Concrete Superstructure.
 Parapet and wearing surface reinforcement shall be paid for as Reinforcement Bars, Epoxy Coated.
 Approach footing concrete shall be paid for as Concrete Structures.
 The top surface of precast bridge approach slabs shall be roughened to a depth of 1/4" according to the IDOT "Manual for Fabrication of Precast Prestressed Concrete Products."
 After precast bridge approach slab has been erected, holes shall be drilled into abutment and anchor dowels placed. Dowel holes shall be filled with non-shrink grout to top of precast slab and allowed to cure fully prior to grouting the longitudinal shear keys.
 Two 1/8" fabric adjusting shims of the dimensions of the exterior bearing pad shall be provided for each bearing pad location. Cost included with Precast Bridge Approach Slab.
 A minimum 2 1/2" diameter lifting pins shall be used to engage the lifting loops during handling.
 Compressive strength of precast concrete, f'c shall be 6,000 psi.
 For additional parapet details, see sheet 10 of 31.
 Any concrete poured monolithically with the wearing surface, such as curbs, will not be paid for separately, but will be included in the cost of Concrete Wearing Surface, 5".
 The strip seal shall be made continuous and shall have a minimum thickness of 1/4". The strip seal shall extend 6" beyond the edge of the approach slab on each end. The configuration of the strip seal shall match the configuration of the Locking Edge Rails.
 The height and thickness of the Locking Edge Rails shown are minimum dimensions. The actual configuration of the Locking Edge Rails and matching strip seal may vary from manufacturer to manufacturer. Flanged edge rails will not be allowed.
 The inside of the Locking Edge Rail groove shall be free of weld residue. Locking Edge Rails may be spliced at slope discontinuities and stage construction joints.
 The manufacturer's recommended installation methods shall be followed.
 All steel components shall be galvanized after fabrication according to Article 520.03 of the Standard Specifications.
 Maximum space between rail segments at stage lines shall be 3/16", sealed with a suitable sealant

TWO APPROACHES BILL OF MATERIAL

| Bar | No. | Size | Length | Shape |
|----------------------------------|-----|---------|--------|-------|
| a5(E) | 62 | #4 | 39'-4" | ▬ |
| a6(E) | 60 | #4 | 7'-5" | ▬ |
| b3(E) | 8 | #4 | 14'-8" | ▬ |
| b4(E) | 66 | #4 | 29'-8" | ▬ |
| b5(E) | 2 | #4 | 14'-3" | ▬ |
| b6(E) | 2 | #4 | 15'-4" | ▬ |
| d(E) | 68 | #5 | 5'-7" | ▬ |
| d2(E) | 68 | #5 | 5'-11" | ▬ |
| e10(E) | 32 | #4 | 14'-8" | ▬ |
| e11(E) | 4 | #8 | 14'-8" | ▬ |
| f(E) | 136 | #4 | 11'-4" | ▬ |
| w(E) | 80 | #5 | 38'-8" | ▬ |
| Concrete Superstructure | | Cu. Yd. | 6.7 | |
| Concrete Structures | | Cu. Yd. | 28.3 | |
| Reinforcement Bars, Epoxy Coated | | Pound | 8890 | |
| Precast Bridge Approach Slab | | Sq. Ft. | 2030 | |
| Concrete Wearing Surface, 5" | | Sq. Yd. | 229.8 | |
| Preformed Joint Strip Seal | | Foot | 78.0 | |

BA-P-R

12-12-12

(Beams: 36" min. width; 72" max. width)

| | | |
|----------------------------|---|-------------------------|
| DESIGNED - Justin T. Belue | EXAMINED - <i>Joanne F. [Signature]</i> | DATE - OCTOBER 16, 2014 |
| CHECKED - David H. Richter | PASSED - <i>Carl [Signature]</i> | REVISED - |
| DRAWN - h.t. duong | | REVISED - |
| CHECKED - JTB/DHR | | |

| | |
|----------------------------|---|
| ACTING ENGINEER OF BRIDGES | ACTING ENGINEER OF BRIDGES AND STRUCTURES |
|----------------------------|---|

| | |
|-------------------------|-----------|
| DATE - OCTOBER 16, 2014 | REVISED - |
| | REVISED - |

STATE OF ILLINOIS
DEPARTMENT OF TRANSPORTATION

PRECAST BRIDGE APPROACH SLAB
STRUCTURE NO. 015-0076

SHEET NO. 15 OF 31 SHEETS

| | | | | |
|--------------------|---------------------|--------------|---------------------------|--------------|
| F.A.P. RTE. 749 | SECTION (122BRIB-1) | COUNTY COLES | TOTAL SHEETS 60 | SHEET NO. 32 |
| CONTRACT NO. 74350 | | | ILLINOIS FED. AID PROJECT | |