

**DETAIL OF COVER PLATE AND FILL PLATE**  
at Stringer S2, S3, S4, S5 and S6

\* Remove existing fill  $\bar{L}$  and center proposed fill  $\bar{L}$  along  $\bar{C}$  stringer line, attach to proposed top cover  $\bar{L}$

**ELEVATION - FLOORBEAM L22**

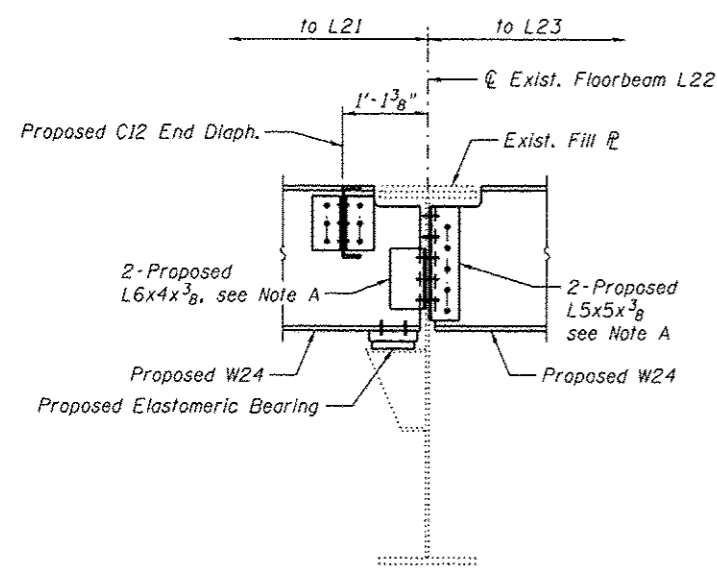

**SECTION A-A**

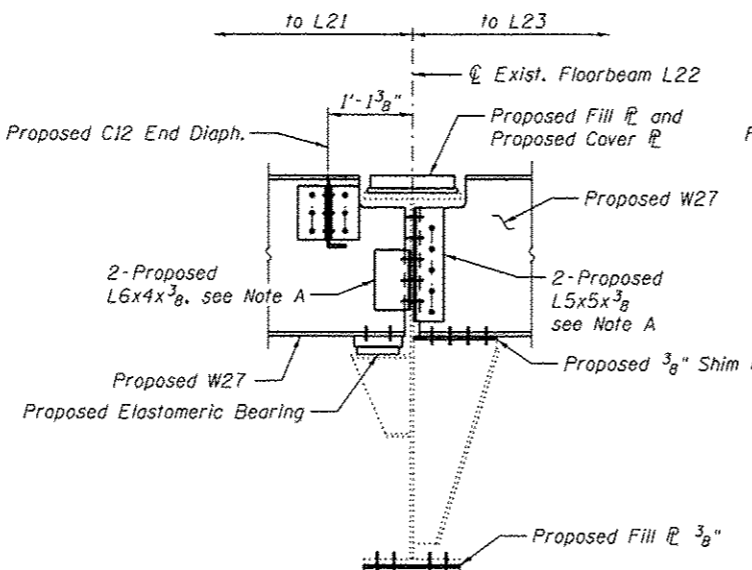

**SECTION B-B**

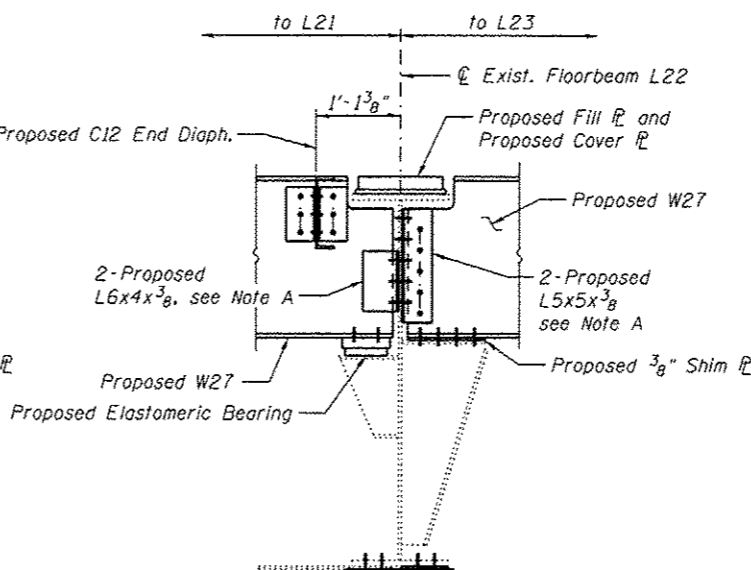

**SECTION C-C**

Note A:  
Field drill holes using existing holes as template. Remainder of holes may be shop or field drilled.

Notes:  
For diaphragm and connection angle details, see sheet S24.  
For elastomeric bearing details and quantities, see sheet S23.  
For additional cover plate details for floorbeam strengthening, see sheet S21.  
Cost of stringer connection angles and shim plates shall be included in Furnishing and Erecting Structural Steel.  
Cost of cover plates and fill plates shall be included in Structural Steel Repair.  
Load carrying components designated "NTR" shall conform to the Impact Testing Requirement, Zone 2.

**BILL OF MATERIAL**

Item	Unit	Total
Structural Steel Repair	Pound	3,430



USER NAME *	DESIGNED - MEL/YSS	REVISED
	CHECKED - COB/ZJB	REVISED
PLOT SCALE *	DRAWN - PRC	REVISED
PLOT DATE * 05/02/2014	CHECKED - MEL/YSS	REVISED

STATE OF ILLINOIS  
DEPARTMENT OF TRANSPORTATION

MAIN SPANS GRID DECK FRAMING DETAILS - 3  
S.N. 082-6001 MLK BRIDGE OVER MISSISSIPPI RIVER

SHEET NO. S19 OF S138 SHEETS

F.A.P. RTE. 799	SECTION 1BR, ORS-2	COUNTY ST. CLAIR	TOTAL SHEETS 156	SHEET NO. 37
ILLINOIS FED. AID PROJECT			CONTRACT NO. 76B03	