

FOR INDEX OF SHEETS, SEE SHEET NO. 2

FOR LIST OF STANDARDS, SEE SHEET NO. 2

MLK BRIDGE (OTHER PRINCIPAL ARTERIAL)

ADT = 26000 (2011)

ADT = 26700 (2015)

ADT = 30700 (2032)

SU = 1.9%

MU = 6.2%

POSTED SPEED = 45 MPH

STATE OF ILLINOIS 11-21-14 LETTING ITEM 101
DEPARTMENT OF TRANSPORTATION
DIVISION OF HIGHWAYS

PROPOSED
HIGHWAY PLANS

FAP ROUTE 799 ILLINOIS AVENUE OVER THE MISSISSIPPI RIVER
SECTION 1BR, DRS-2

PROJECT NO. ACNHPP-0799 (003)

PARTIAL DECK REPLACEMENT AND STRUCTURAL REPAIRS
ST. CLAIR COUNTY

JOB NO. C-98-080-07

F.A.P. RITE	SECTION	COUNTY	TOTAL SHEETS	SHEET NO.
799	1BR, DRS-2	ST. CLAIR	156	1
FED. ROAD DIST. NO. 8	ILLINOIS	CONTRACT NO. 76B03		

* 156 + 11 + 167 TOTAL SHEETS

D-98-074-07

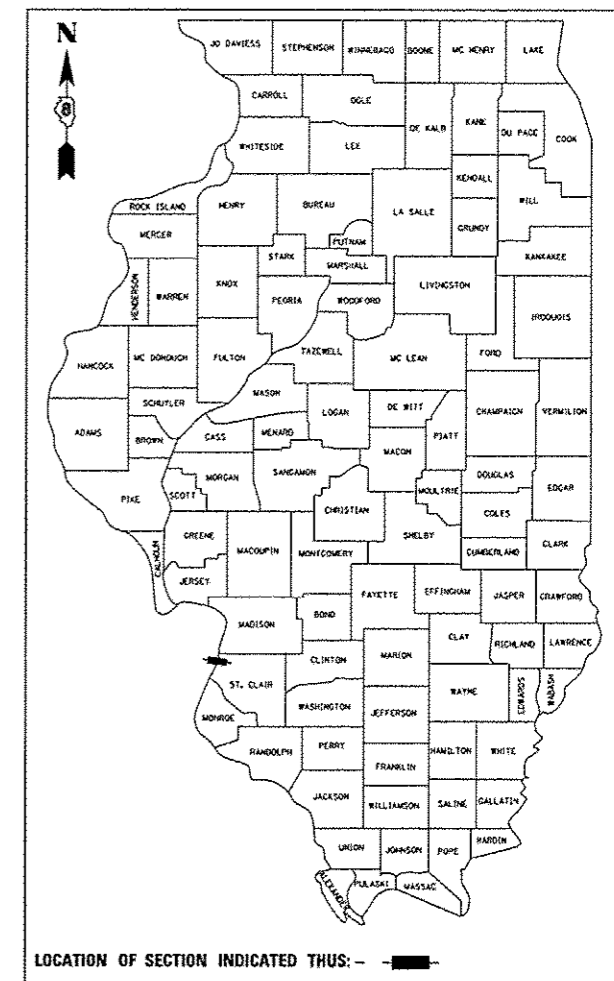

Jerilyn M. Hassard
5/2/14

EXP. 11-30-15

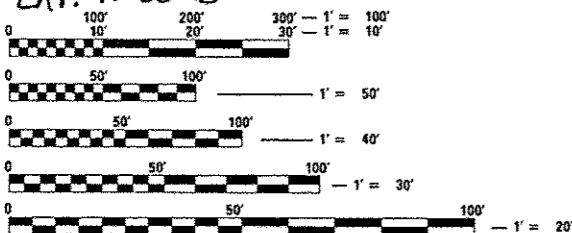

FULL SIZE PLANS HAVE BEEN PREPARED USING STANDARD ENGINEERING SCALES. REDUCED SIZED PLANS WILL NOT CONFORM TO STANDARD SCALES. IN MAKING MEASUREMENTS ON REDUCED PLANS, THE ABOVE SCALES MAY BE USED.

J.U.L.I.E.
JOINT UTILITY LOCATION INFORMATION FOR EXCAVATION
1-800-892-0123
OR 811
MISSOURI ONE CALL (800 DIG RITE)

PROJECT ENGINEER: TIM PADGETT
PROJECT MANAGER: PHIL COPPERNOLL
CONTRACT NO.: 76B03

(618) 346-3325
(618) 346-3480

MLK BRIDGE & 3RD ST
BEGIN IMPROVEMENTS
STA. 3 + 28.07

MLK BRIDGE
SN 082-6001

MLK BRIDGE
END IMPROVEMENTS
STA. 43 + 38.39

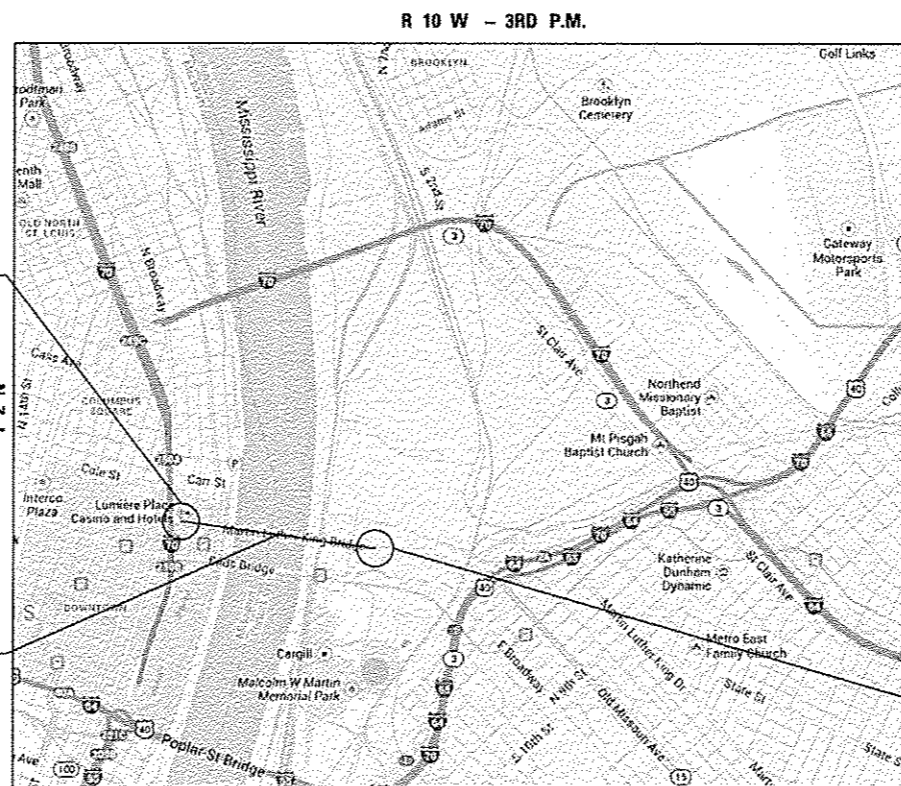

EAST ST. LOUIS TOWNSHIP
ST. CLAIR COUNTY
LOCATION MAP

GROSS AND NET LENGTH OF IMPROVEMENT = 4010.32 FT = 0.76 MILES

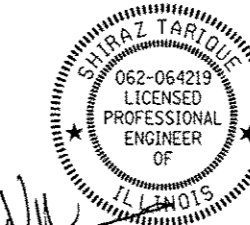

Shiraz Tarique
5/2/14
SHIRAZ TARIQUE, P.E.
ILLINOIS REGISTERED ENGINEER NO. 062-064219
REGISTRATION EXPIRES NOV. 30, 2015



E LIN ENGINEERING, LTD.
WESTMONT, ILLINOIS 60559
(630) 323-5168

STATE OF ILLINOIS
DEPARTMENT OF TRANSPORTATION
DIVISION OF HIGHWAYS

SUBMITTED *Mar 21 20 14*

Jeffrey Z. Kan
DEPUTY DIRECTOR OF HIGHWAYS, REGION ENGINEER

John D. Baranelli, P.E.
ENGINEER OF DESIGN AND ENVIRONMENT

May 9 20 14

Chris Osman, P.E.
DIRECTOR OF HIGHWAYS, CHIEF ENGINEER

PRINTED BY THE AUTHORITY
OF THE STATE OF ILLINOIS

INDEX OF SHEETS

- 1 COVER SHEET
- 2 INDEX OF SHEETS, HIGHWAY STANDARDS, COMMITMENTS, GENERAL NOTES
- 3-6 SUMMARY OF QUANTITIES
- * 7-181 TRAFFIC CONTROL PROTECTION PLAN
- ** 19-156 STRUCTURAL SHEETS

* INCLUDES 18A-18H

** INCLUDES 67A, 68A AND 72A

HIGHWAY STANDARDS

- 000001-06 ABBREVIATIONS, SYMBOLS, AND PATTERNS
- 001001-02 REINFORCEMENT BARS, AREAS, WEIGHTS AND SPACING
- 001006 DECIMAL EQUIVALENTS OF AN INCH AND FOOT
- 664001-02 FENCE, CHAIN LINK
- 701400-07 APPROACH TO LANE CLOSURE, FREEWAY/EXPRESSWAY
- 701401-08 LANE CLOSURE, FREEWAY/EXPRESSWAY
- 701428 TRAFFIC CONTROL SETUP AND REMOVAL FREEWAY/EXPRESSWAY
- 701801-05 SIDEWALK, CORNER OR CROSSWALK CLOSURE
- 701901-03 TRAFFIC CONTROL DEVICES

COMMITMENTS

- A. LANE CLOSURES - THE CONTRACTOR WILL NOT BE ALLOWED TO CLOSE THE ROAD OR ANY TRAFFIC LANES IN THE CITY OF ST. LOUIS ON LEONOR K SULLIVAN, COMMERCIAL STREET, 1ST STREET, 2ND STREET, AND LACLEDE'S LANDING BLVD THURSDAY THRU SUNDAY NIGHTS, HOLIDAYS, THE WEDNESDAY BEFORE THANKSGIVING, OR FOR MAJOR EVENTS AS DETERMINED BY THE ENGINEER FROM 4:00 PM TO 4:00 AM.
- B. IF THE WROUGHT IRON FENCE ON STATE ROW UNDER THE MKL STRUCTURE IN MISSOURI NEEDS TO BE REMOVED FOR ANY REASON, THE CONTRACTOR SHALL EXERCISE CARE WHEN REMOVING. THE CONTRACTOR SHALL BE RESPONSIBLE FOR RE-ENACTING THE WROUGHT IRON FENCE TO ITS ORIGINAL CONDITION. ANY COST RELATED TO THIS WORK SHALL BE AT THE CONTRACTOR'S EXPENSE.

GENERAL NOTES

1. THE STANDARDS AND REVISION NUMBERS SHALL APPLY TO THIS PROJECT.
2. PLAN DIMENSIONS AND DETAILS RELATIVE TO EXISTING PLANS ARE SUBJECT TO VARIATIONS FOUND IN THE FIELD. THE CONTRACTOR SHALL FIELD VERIFY EXISTING DIMENSIONS AND DETAILS AFFECTING NEW CONSTRUCTION AND MAKE NECESSARY ADJUSTMENTS PRIOR TO CONSTRUCTION OR ORDERING MATERIALS. ANY ADJUSTMENTS PROPOSED BY THE CONTRACTOR MUST BE APPROVED BY THE ENGINEER. SUCH VARIATIONS SHALL NOT BE CAUSE FOR ADDITIONAL COMPENSATION FOR A CHANGE IN THE SCOPE OF WORK. HOWEVER, THE CONTRACTOR WILL BE PAID FOR THE QUANTITY ACTUALLY FURNISHED BASED UPON THE UNIT PRICE.
3. THE ILLINOIS DEPARTMENT OF TRANSPORTATION STRONGLY ENCOURAGES THE PRIME CONTRACTOR AND THEIR APPROVED SUB-CONTRACTORS TO HIRE MINORITY, WOMEN AND DISADVANTAGED INDIVIDUALS FROM ITS FEDERALLY FUNDED HIGHWAY CONSTRUCTION CAREERS TRAINING PROGRAM (HCCTP) TO HELP MEET WORKFORCE AND TRAINEE GOALS. THIS PROGRAM IS TRAINING MINORITIES, WOMEN AND DISADVANTAGED INDIVIDUALS IN HIGHWAY CONSTRUCTION-RELATED SKILLS, E.G. MATH FOR THE TRADES, JOB READINESS, TECHNICAL SKILLS COURSEWORK (CARPENTRY, CONCRETE FLATWORK, BLUEPRINT READING, SITE PLANS, SITE WORK, TOOL USE, ETC.) AND OSHA 10 HOUR CERTIFICATION. TO PREPARE THEM FOR A CAREER IN THE HIGHWAY CONSTRUCTION TRADES. GRADUATES ARE WELL-TRAINED AND READY TO BECOME PRODUCTIVE ENTRY-LEVEL CONSTRUCTION WORKERS.

PLEASE CONTACT THE DISTRICT 8 EED OFFICE AT 618-346-3360 AND/OR THE HCCTP COORDINATOR AT 618-874-6528 TO LEARN MORE ABOUT THE PROGRAM AND FOR ASSISTANCE IN MEETING WORKFORCE AND TRAINEE GOALS.
4. FOR INFORMATION ABOUT THE OWNERSHIP OF THE PROPERTY UNDER THE MKL STRUCTURE IN MISSOURI, CONTACT JOHN CLARK AT 314-409-4885.
5. ILLINOIS STATE LAW REQUIRES A 48-HOUR NOTICE BE GIVEN TO ALL UTILITIES WITHIN THE PROJECT AREA BEFORE DIGGING BY CALLING J.U.L.I.E. AND BY NOTIFYING NON-J.U.L.I.E. MEMBERS INDIVIDUALLY. AGENCIES KNOWN TO HAVE FACILITIES WITHIN THE PROJECT AREA ARE AS FOLLOWS:

AMEREN ILLINOIS*
AT&T ILLINOIS*
EXPLORER PIPELINE COMPANY*
ILLINOIS AMERICAN WATER COMPANY*
LACLEDE PIPELINE COMPANY*
LIGHTCORE*
VERIZON BUSINESS*
MCLEOD TELECOMMUNICATIONS SERVICES, LLC*
QWEST SOLUTIONS CENTER*
SPRINT/NEXTEL*

(MEMBERS OF J.U.L.I.E. CALL TOLL FREE (800)892-0123 OR 811 AND ARE INDICATED BY *. NON-J.U.L.I.E. MEMBERS MUST BE NOTIFIED INDIVIDUALLY.)
6. THE PROPOSED PAVEMENT MARKING SHALL MATCH THE LOCATIONS OF THE EXISTING PAVEMENT MARKING, AS DIRECTED BY THE ENGINEER.
7. PROPERTY LINES AND/OR EXISTING ROW SHOWN IN APPROXIMATE.
8. ALL ELEVATIONS REFER TO THE NAVD88 VERTICAL DATUM, UNLESS OTHERWISE NOTED.
9. EXISTING PAVEMENT MARKINGS SHALL BE TEMPORARILY COVERED PRIOR TO APPLICATION OF THE DECK SURFACE TREATMENT TO PREVENT THE MATERIAL FROM BEING APPLIED TO THE MARKINGS AND TO PROTECT THE REFLECTIVE PROPERTIES OF THE MARKINGS. THE TEMPORARY COVERING MATERIAL USED SHALL BE SUCH THAT IT WILL NOT AFFECT THE MARKINGS' REFLECTIVITY WHEN REMOVED AFTER APPLICATION OF THE DECK SURFACE TREATMENT AND PRIOR TO OPENING TO TRAFFIC. COST IS INCLUDED WITH THE DECK SURFACE TREATMENT SPECIFIED.
10. EXISTING STRUCTURE PLANS ARE AVAILABLE FOR REVIEW IN THE DISTRICT OFFICE. CONTACT TIM PADGETT AT (618)346-3325.
11. ALL TURF AREAS DISTURBED BY THE CONTRACTOR SHALL BE SEEDED WITH THE APPROPRIATE EROSION CONTROL, AS DIRECTED BY THE ENGINEER, AT THE CONTRACTOR'S EXPENSE.
12. ACCESS TO THE STATE OF ILLINOIS ROW UNDER THE STRUCTURE WEST OF THE LEVEE ON THE ILLINOIS SIDE WILL BE FROM THE MISSISSIPPI RIVER. THE CONTRACTOR WILL BE ALLOWED TO OFF-LOAD MATERIALS AND EQUIPMENT FROM THE RIVER ACCESS AFTER PROCURING A PERMIT FROM THE ILLINOIS DEPARTMENT OF NATURAL RESOURCES (IDNR), BUT SHALL NOT DISTURB THE LEVEE IN ANY WAY.
13. THE CONTRACTOR SHALL NOTE THAT THE PROPERTY BENEATH THE STRUCTURE IN THE CITY OF ST. LOUIS BETWEEN FIRST STREET AND SECOND STREET IS OWNED BY BLOCK 25 WITH LIMITED STATE ROW AROUND THE PIER FOUNDATIONS. THE STATE MAINTAINS AIR RIGHTS ABOVE DATUM 475.69 USGS IN THESE AREAS. CONSTRUCTION ACCESS WILL BE LIMITED TO STATE ROW AND AIR RIGHTS ONLY AT THIS LOCATION.
14. TWO WEEKS PRIOR TO ANY LANE CLOSURES, THE ENGINEER WILL CONTACT THE AGENCIES LISTED BELOW:
1. ST. CLAIR COUNTY TRANSIT DISTRICT, (618) 628-8090, ATTN: BILL GROGAN
2. MADISON COUNTY TRANSIT DISTRICT, FAX (618) 797-7547
3. EAST ST. LOUIS POLICE DEPARTMENT, (618) 482-6767
4. EAST ST. LOUIS FIRE DEPARTMENT, (618) 482-6840
5. ST. CLAIR COUNTY EMERGENCY TELEPHONE SYSTEM BOARD,
FAX (618) 277-7688, ATTN: CAROLYN LIGON
6. DISTRICT 8 TRAFFIC MANAGEMENT CENTER, (618) 346-3233
7. CITY OF ST. LOUIS, (314) 647-3111, ATTN: TODD WALTERMANN
8. MISSOURI DEPARTMENT OF TRANSPORTATION, (314) 877-0118, ATTN: DEANNA VENKER
9. MISSOURI DEPARTMENT OF TRANSPORTATION TRAFFIC MANAGEMENT CENTER
(314) 275-1513
15. RAILROAD FLAGGERS, IF REQUIRED, SHALL BE PAID FOR ACCORDING TO ARTICLE 109.04 OF THE STANDARD SPECIFICATIONS.

FILE NAME *	USER NAME * haydend	DESIGNED -	REVISED -	STATE OF ILLINOIS DEPARTMENT OF TRANSPORTATION	INDEX OF SHEETS, HIGHWAY STANDARDS, GENERAL NOTES, COMMITMENTS		F.A.P. RTE.	SECTION	COUNTY	TOTAL SHEETS	SHEET NO.	
al\p...work\p...dot\haydend\...32153\0876	83-shi-gemnotadgn	DRAWN -	REVISED -		799	1BR, DRS-2	ST. CLAIR	156	2	CONTRACT NO. 76803		
	PLOT SCALE * 100.0000 1/16"	CHECKED -	REVISED -		SCALE:	SHEET NO. 1 OF 1 SHEETS	STA. _____ TO STA. _____	FED. ROAD DIST. NO. [ILLINOIS] FED. AID PROJECT				
	PLOT DATE * 9/26/2014	DATE -	REVISED -									

CODE NO.	ITEM	UNIT	TOTAL QUANTITY	CONSTRUCTION CODE					
				0014	0040	0043			
				BRIDGE REHAB	SIGN STRUCTURES	UTILITIES			
				80/20 FED/ST	80/20 FED/ST	80/20 FED/ST			
20100210	TREE REMOVAL (OVER 15 UNITS DIAMETER)	UNIT	300	300					
28100813	STONE DUMPED RIPRAP, CLASS A7	TON	35,085	35,085					
50102400	CONCRETE REMOVAL	CU. YD.	109.1	105.8	3.3				
50157300	PROTECTIVE SHIELD	SQ. YD.	617	617					
50300100	FLOOR DRAINS	EACH	100	100					
50300255	CONCRETE SUPERSTRUCTURE	CU. YD.	110	105.2	4.8				
50300260	BRIDGE DECK GROOVING	SQ. YD.	3,058	3,058					
50500105	FURNISHING AND ERECTING STRUCTURAL STEEL	L. SUM	1	1					
50500505	STUD SHEAR CONNECTIONS	EACH	19,740	19,740					
50800205	REINFORCEMENT BARS, EPOXY COATED	POUND	20,850	19,820	1,030				
50800530	MECHANICAL SPLICERS	EACH	6		6				
52000110	PREFORMED JOINT STRIP SEAL	FOOT	504	504					
52000600	FABRIC REINFORCED ELASTOMERIC TROUGH	FOOT	214	214					
52100010	ELASTOMERIC BEARING ASSEMBLY, TYPE 1	EACH	35	35					

USER NAME * #USER*	DESIGNED - JAH	REVISED -
PLOT SCALE * #SCALE*	DRAWN - JAH	REVISED -
PLOT DATE * #DATE*	CHECKED - GRE	REVISED -
	DATE - 2/2014	REVISED -

STATE OF ILLINOIS
DEPARTMENT OF TRANSPORTATION

SUMMARY OF QUANTITIES	
MLK BRIDGE OVER MISSISSIPPI RIVER	
SCALE: N.T.S.	SHEET NO. 1 OF 4 SHEETS
STA.	TO STA.

F.A.P. RTE.	SECTION	COUNTY	TOTAL SHEETS	SHEET NO.
799	1BR. DRS-2	ST. CLAIR	156	3
			CONTRACT NO. 76803	
ILLINOIS FED. AID PROJECT				

CODE NO.	ITEM	UNIT	TOTAL QUANTITY	CONSTRUCTION CODE							
				0014		0040		0043			
				BRIDGE REHAB		SIGN STRUCTURES		UTILITIES			
				80/20	FED/ST	80/20	FED/ST	80/20	FED/ST		
59000200	EPOXY CRACK INJECTION	FOOT	176	176							
66400505	CHAIN LINK FENCE, 8 FT	FOOT	1,884	1,884							
66409200	CHAIN LINK GATES, 8'X8' DOUBLE	EACH	4	4							
67100100	MOBILIZATION	L SUM	1	1							
67000400	ENGINEER'S FIELD OFFICE, TYPE A	CAL MO	12	12							
70102640	TRAFFIC CONTROL AND PROTECTION, STANDARD 701801	L SUM	1	1							
70106800	CHANGEABLE MESSAGE SIGN	CAL MO	44	44							
78100105	RAISED REFLECTIVE PAVEMENT MARKER (BRIDGE)	EACH	20	20							
* 78003130	PREFORMED PLASTIC PAVEMENT MARKING, TYPE B - LINE 6"	FOOT	4,065	4,065							
X0320622	FIELD MEASUREMENTS	L SUM	1	1							
* X0321519	CONDUIT SUPPORT SYSTEM	L. SUM	1				1				
70107005	PAVEMENT MARKING BLACKOUT TAPE, 5"	FOOT	400	400							
* X0325541	REMOVE EXISTING LIGHTING SYSTEM	L. SUM	1	1							
70107009	PAVEMENT MARKING BLACKOUT TAPE, 9"	FOOT	225	225							
X0325583	REMOVE AND REINSTALL FINGER PLATE JOINT	EACH	3	3							
70300530	PAVEMENT MARKING TAPE, TYPE III 5"	FOOT	2,674	2,674							
X0325941	ACCESS LADDER	EACH	3	3							
70300550	PAVEMENT MARKING TAPE, TYPE III 8"	FOOT	1850	1850							
X0326275	RAILROAD RIGHT-OF-WAY ENTRY PERMIT	EACH	1	1							
70300560	PAVEMENT MARKING TAPE, TYPE III 12"	FOOT	271	271							
X0326534	REMOVE AND REINSTALL EXISTING ALUMINUM PARAPET	FOOT	1,905	1,905							
70301000	WORK ZONE PAVEMENT MARKING REMOVAL	SQ. FT.	2,952	2,952							
X5870015	BRIDGE DECK CONCRETE SEALER	SQ. FT.	193,439	193,439							
70400100	TEMPORARY CONCRETE BARRIER	FOOT	3,150	3,150							
X6300231	STEEL POST, ATTACHED TO STRUCTURES	EACH	812	812							
70600251	IMPACT ATTENUATORS, TEMPORARY (NON-REDIRECTIVE, NARROW), TEST LEVEL 3	EACH	2	2							

* SPECIALTY ITEM

USER NAME * #USER*	DESIGNED - JAH	REVISED -
PLOT SCALE * #SCALE*	DRAWN - JAH	REVISED -
PLOT DATE * #DATE*	CHECKED - GRE	REVISED -
	DATE - 2/2014	REVISED -

STATE OF ILLINOIS
DEPARTMENT OF TRANSPORTATION

SUMMARY OF QUANTITIES
MLK BRIDGE OVER MISSISSIPPI RIVER

F.A.P. RTE.	SECTION	COUNTY	TOTAL SHEETS	SHEET NO.
799	18R, ORS-2	ST. CLAIR	156	4
SCALE: N.T.S.			SHEET NO. 2 OF 4 SHEETS	STA. TO STA.
ILLINOIS FED. AID PROJECT				

CONTRACT NO. 76B03

CODE NO.	ITEM	UNIT	TOTAL QUANTITY	CONSTRUCTION CODE						
				0014		0040		0043		
				BRIDGE REHAB		SIGN STRUCTURES		UTILITIES		
				80/20	FED/ST	80/20	FED/ST	80/20	FED/ST	
X7010216	TRAFFIC CONTROL AND PROTECTION, (SPECIAL)	L. SUM	1	1						
X7010410	SPEED DISPLAY TRAILER	CAL MO	10	10						
* X7330310	OVERHEAD SIGN STRUCTURE - SPAN, DUAL MONOTUBE	FOOT	45		45					
* X7830074	GROOVING FOR RECESSED PAVEMENT MARKING 7"	FOOT	4,065	4,065						
* X8260110	NAVIGATION LIGHTING SYSTEM	L. SUM	1	1						
Z0001898	ADJUST AND REPOSITION BEARINGS	EACH	14	14						
Z0001905	STRUCTURAL STEEL REPAIR	POUND	179,190	179,190						
Z0006710	BRIDGE DRAINAGE SYSTEM REPAIR	EACH	10	10						
Z0007101	CONTAINMENT AND DISPOSAL OF LEAD PAINT CLEANING RESIDUES NO. 1	L. SUM	1	1						
Z0010501	CLEANING AND PAINTING STEEL BRIDGE NO. 1	L. SUM	1	1						
Z0010605	CLEANING DRAINAGE SYSTEM	L. SUM	1	1						
Z0012754	STRUCTURAL REPAIR OF CONCRETE (DEPTH EQUAL TO OR LESS THAN 5 IN.)	SQ. FT.	95	95						
Z0016200	DECK SLAB REPAIR (PARTIAL)	SQ. YD.	324	324						
Z0016702	DETOUR SIGNING	L. SUM	1	1						
Z0018800	DRAINAGE SYSTEM	L. SUM	1	1						

* SPECIALTY ITEM

USER NAME * #USER*	DESIGNED - JAH	REVISED -
	DRAWN - JAH	REVISED -
PLOT SCALE * #SCALE*	CHECKED - GRE	REVISED -
PLOT DATE * #DATE*	DATE - 3/2014	REVISED -

STATE OF ILLINOIS
DEPARTMENT OF TRANSPORTATION

SUMMARY OF QUANTITIES
MLK BRIDGE OVER MISSISSIPPI RIVER

F.A.P. RTE.	SECTION	COUNTY	TOTAL SHEETS	SHEET NO.
799	1BR, DRS-2	ST. CLAIR	156	5
SCALE: N.T.S.			SHEET NO. 3 OF 4 SHEETS	STA. TO STA.
ILLINOIS FED. AID PROJECT				

CONTRACT NO. 76B03

NO 0041

50/50 ILLINOIS / MISSOURI

CODE NO.	ITEM	UNIT	TOTAL QUANTITY	CONSTRUCTION CODE						
				0014	0040	0043				
				BRIDGE REHAB	SIGN	UTILITIES				
					STRUCTURES					
				80/20 FED/ST	80/20 FED/ST	80/20 FED/ST				
Z0021906	SILICONE JOINT SEALER, 1.5"	FOOT	300	300						
Z0032300	JACKING EXISTING SUPERSTRUCTURE	L. SUM	1	1						
Z0041895	POLYMER CONCRETE	CU. FT.	5	5						
Z0048665	RAILROAD PROTECTIVE LIABILITY INSURANCE	L. SUM	1	1						
Z0065700	SLOPE WALL REPAIR	SO. YD.	9.1	9.1						
Z0072900	TEMPORARY RAILROAD CROSSING	EACH	1	1						
∅ Z0076600	TRAINEES	Hour	2500	2500						
X5010110	REMOVAL OF EXISTING FILLED GRID DECK	L. SUM	1	1						
∅ Z0076604	TRAINEES TRAINING PROGRAM GRADUATE	Hour	2500	2500						
X0327760	STEEL GRID DECK	SO. FT.	31,026	31,026						
X0327761	CONCRETE BARRIER REPAIR	L. SUM	1	1						
X0327762	RAILROAD FLAGGER	L. SUM	1	1						

∅ 0042

USER NAME * #USER#	DESIGNED - JAH	REVISED -	STATE OF ILLINOIS DEPARTMENT OF TRANSPORTATION	SUMMARY OF QUANTITIES MLK BRIDGE OVER MISSISSIPPI RIVER			F.A.P. RTE.	SECTION	COUNTY	TOTAL SHEETS	SHEET NO.
PLOT SCALE * #SCALE#	DRAWN - JAH	REVISED -		SCALE: N.T.S.	SHEET NO. 4 OF 4 SHEETS	STA.	799	1BR, ORS-2	ST. CLAJR	156	6
PLOT DATE * #DATE#	CHECKED - GRE	REVISED -		TO STA.			CONTRACT NO. 76BD3		ILLINOIS FED. AID PROJECT		
	DATE - 3/2014	REVISED -									

DETOUR PLAN SHEETS
 LANE CLOSURE & SIGN MODIFICATION PLAN SHEETS

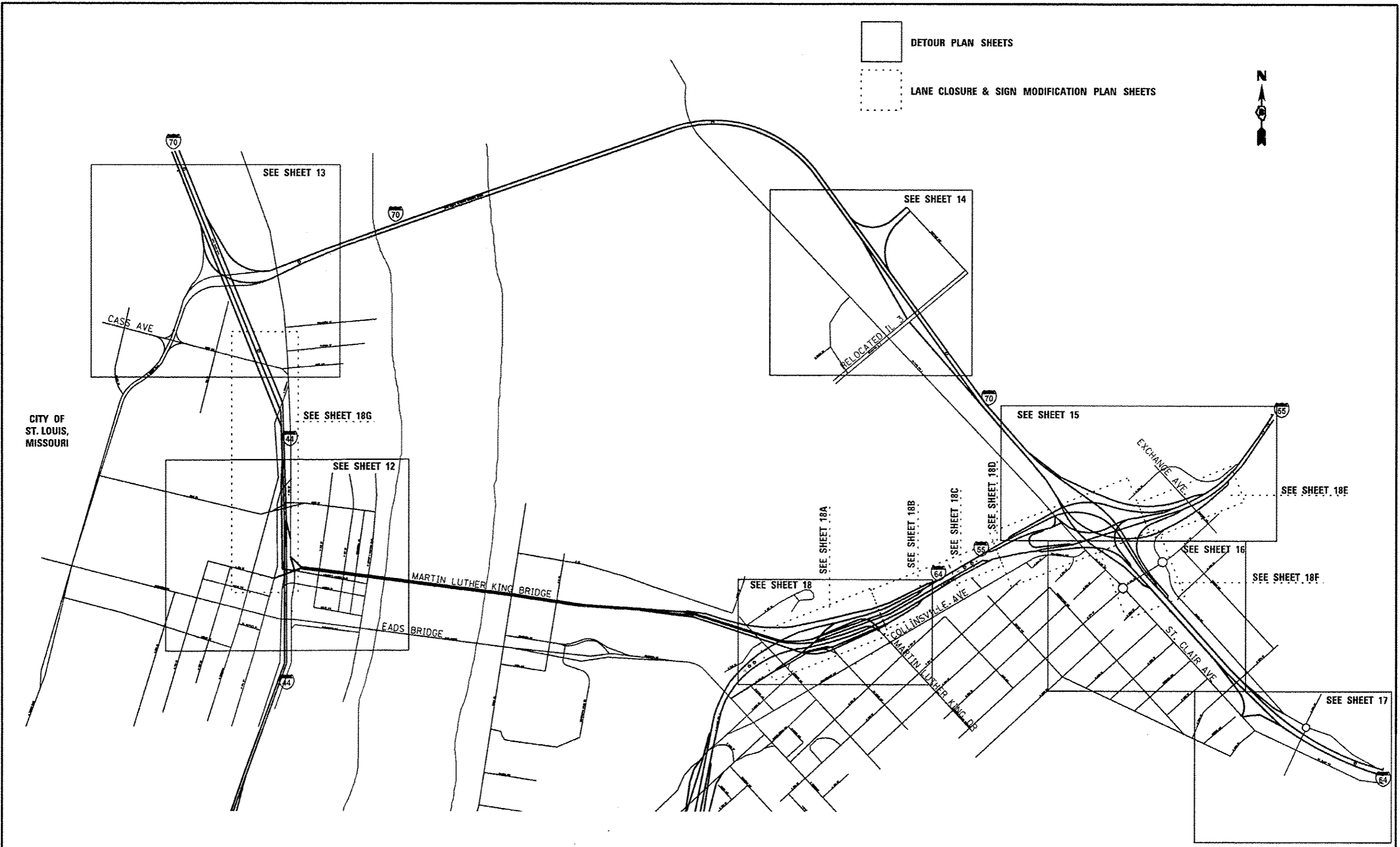

NOT TO SCALE

FILE NAME *	USER NAME * haydend	DESIGNED -	REVISED -	STATE OF ILLINOIS DEPARTMENT OF TRANSPORTATION	TRAFFIC CONTROL PROTECTION PLAN KEY MAP	F.A.P. RTE.	SECTION	COUNTY	TOTAL SHEETS	SHEET NO.	
as\pe-work\pds\dts\haydend\dms52153\0876	87-ahs-a-tagimg.dgn	DRAWN -	REVISED -			799	1BR, DRS-2	ST. CLAIR	156	7	
	PLOT SCALE * 100.0000 "/>	CHECKED -	REVISED -			CONTRACT NO. 76803					
	PLOT DATE * 9/26/2014	DATE -	REVISED -			FED. ROAD DIST. NO. ILLINOIS FED. AID PROJECT					

DETOUR SIGNING NOTES:

- SIX CHANGEABLE MESSAGE SIGNS SHALL BE REQUIRED FOR THIS PROJECT IN ADDITION TO ANY REQUIRED FOR TRAFFIC CONTROL AND PROTECTION STANDARDS. CHANGEABLE MESSAGE SIGNS SHALL BE PLACED TWO WEEKS PRIOR TO ANY MLK BRIDGE LANE CLOSURES. THE CHANGEABLE MESSAGE SIGNS SHALL BE PLACED AS SHOWN IN THE PLANS OR AT THE DIRECTION OF THE ENGINEER. EACH MESSAGE SIGN SHALL HAVE 3 DRUMS OR TYPE II BARRICADES WITH FLASHING LIGHTS AS SHOWN IN TRAFFIC CONTROL AND PROTECTION, STANDARD 701400.
- THE CONTRACTOR SHALL FURNISH AND INSTALL WOOD SIGN SUPPORTS IN ACCORDANCE WITH SECTION 730 OF THE STANDARD SPECIFICATIONS.
- FOR STABILIZATION, ALL TYPE III BARRICADES SHALL REQUIRE A MINIMUM OF FOUR (4) SAND BAGS PER BARRICADE.
- DURING THE PRE-CLOSURE AND POST-CLOSURE PHASES, ONLY THE EASTBOUND DETOUR SHALL BE ERECTED. EASTBOUND DETOUR SIGNING SHALL BE COVERED DURING HOURS WHEN THE DETOUR IS NOT IN EFFECT. WESTBOUND DETOUR SIGNING AND TRAFFIC CONTROL AND PROTECTION SHALL BE ERECTED DURING THE FULL CLOSURE PHASE ONLY.
- TEMPORARY GREENBOARD SIGN MODIFICATIONS SHALL NOT BE IMPLEMENTED DURING THE PRE-CLOSURE OR POST-CLOSURE PHASES.

TEMPORARY GREEN BOARD SIGN MODIFICATIONS IN ILLINOIS					
SIGN NUMBER	LOCATION	EXISTING SIGN STRUCTURE TYPE	EXISTING SIGN TEXT	SIGN MODIFICATION	CONSTRUCTION PHASE
1	I-55 SB - 0.5 MILES BEFORE EXIT 2C	CANTILEVER TRUSS	EXIT 2C ML KING BRIDGE 1/2 MILE EXIT ↓ ONLY	PLACE "CLOSED" PLAQUE OVER "EXIT ↓ ONLY"	FULL CLOSURE WITH WB DETOUR
2	I-64 WB - 0.5 MILES BEFORE EXIT 2B	SIGN TRUSS	EXIT 2B DOWNTOWN ST LOUIS VIA MLK BRIDGE EXIT ↓ ONLY	PLACE "CLOSED" PLAQUE OVER "EXIT ↓ ONLY"	FULL CLOSURE WITH WB DETOUR
3 (LEFT SIGN)	I-55 SB / I-64 WB - 0.25 MILES BEFORE EXIT 2B	SIGN TRUSS	EXIT 2B ML KING BRIDGE DOWNTOWN ST LOUIS ↓ EXIT ONLY ↓	PLACE "CLOSED" PLAQUE OVER "↓ EXIT ONLY ↓"	FULL CLOSURE WITH WB DETOUR
3 (RIGHT SIGN)	I-55 SB / I-64 WB - 0.25 MILES BEFORE EXIT 2B	SIGN TRUSS	EXIT 2C ML KING BRIDGE DOWNTOWN ST. LOUIS EXIT ↓ ONLY	PLACE "CLOSED" PLAQUE OVER "EXIT ↓ ONLY"	FULL CLOSURE WITH WB DETOUR
4 (LEFT SIGN)	I-55 SB / I-64 WB AT EXIT 2B	SIGN TRUSS	EXIT 2B ML KING BRIDGE DOWNTOWN ST LOUIS ↙ EXIT ONLY ↘	PLACE "CLOSED" PLAQUE OVER "↙ EXIT ONLY ↘"	FULL CLOSURE WITH WB DETOUR
4 (RIGHT SIGN)	I-55 SB / I-64 WB AT EXIT 2B	SIGN TRUSS	EXIT 2C ML KING BRIDGE ↗ DOWNTOWN ST. LOUIS EXIT ONLY	PLACE "CLOSED" PLAQUE OVER "EXIT ONLY"	FULL CLOSURE WITH WB DETOUR

TOTAL NUMBER OF "CLOSED" SIGNS IN ILLINOIS = 6
 TOTAL NUMBER OF SIGNS TO BE COVERED IN ILLINOIS = 0
 COST OF MODIFYING EXISTING GREENBOARD SIGNS TO BE INCLUDED IN THE COST OF THE PAY ITEM FOR TRAFFIC CONTROL AND PROTECTION, (SPECIAL).

TEMPORARY GREEN BOARD SIGN MODIFICATIONS IN MISSOURI					
SIGN NUMBER	LOCATION	EXISTING SIGN STRUCTURE TYPE	EXISTING SIGN TEXT	SIGN MODIFICATION	CONSTRUCTION PHASE
5	I-44 WB - 0.5 MILES BEFORE EXIT 292A	SIGN TRUSS	CONVENTION PLAZA ML KING BRIDGE TO ILLINOIS 1/2 MILE	COVER THE FOLLOWING TEXT "ML KING BRIDGE TO ILLINOIS"	FULL CLOSURE WITH EB DETOUR
6	I-44 WB - 0.125 MILES BEFORE EXIT 292A	SIGN TRUSS	EXIT 292A CONVENTION PLAZA ML KING BRIDGE TO ILLINOIS	COVER THE FOLLOWING TEXT "ML KING BRIDGE TO ILLINOIS"	FULL CLOSURE WITH EB DETOUR
7	I-44 WB - AT EXIT 292A	SIGN TRUSS	EXIT 292A CONVENTION PLAZA ML KING BRIDGE TO ILLINOIS	COVER THE FOLLOWING TEXT "ML KING BRIDGE TO ILLINOIS"	FULL CLOSURE WITH EB DETOUR
8 (LEFT SIGN)	ON EXIT 292A	CANTILEVER DUAL TUBE	3RD ST ML KING BRIDGE TO ILLINOIS	COVER THE FOLLOWING TEXT "ML KING BRIDGE TO ILLINOIS"	FULL CLOSURE WITH EB DETOUR
8 (RIGHT SIGN)	ON EXIT 292A	CANTILEVER DUAL TUBE	LACLEDE'S LANDING BLVD ML KING BRIDGE TO ILLINOIS	COVER THE FOLLOWING TEXT "ML KING BRIDGE TO ILLINOIS"	FULL CLOSURE WITH EB DETOUR
9 (LEFT SIGN)	ON N. 4TH ST.	MONOTUBE	ML KING BRIDGE TO ILLINOIS	PLACE "CLOSED" PLAQUE OVER	FULL CLOSURE WITH EB DETOUR
9 (RIGHT SIGN)	ON N. 4TH ST.	MONOTUBE	LACLEDE'S LANDING BLVD ML KING BRIDGE TO ILLINOIS	COVER THE FOLLOWING TEXT "ML KING BRIDGE TO ILLINOIS"	FULL CLOSURE WITH EB DETOUR
10 (LEFT SIGN)	ON CONVENTION PLAZA	CANTILEVER DUAL TUBE	3RD ST ML KING BRIDGE TO ILLINOIS	COVER THE FOLLOWING TEXT "ML KING BRIDGE TO ILLINOIS"	FULL CLOSURE WITH EB DETOUR
10 (RIGHT SIGN)	ON CONVENTION PLAZA	CANTILEVER DUAL TUBE	LACLEDE'S LANDING BLVD ML KING BRIDGE TO ILLINOIS	COVER THE FOLLOWING TEXT "ML KING BRIDGE TO ILLINOIS"	FULL CLOSURE WITH EB DETOUR

TEMPORARY GREEN BOARD SIGN MODIFICATIONS IN MISSOURI (CONTINUED)					
SIGN NUMBER	LOCATION	EXISTING SIGN STRUCTURE TYPE	EXISTING SIGN TEXT	SIGN MODIFICATION	CONSTRUCTION PHASE
11 (MIDDLE SIGN)	ON MEMORIAL DRIVE	CANTILEVER DUAL TUBE	ML KING BRIDGE TO ILLINOIS	PLACE "CLOSED" PLAQUE OVER	FULL CLOSURE WITH EB DETOUR
11 (RIGHT SIGN)	ON MEMORIAL DRIVE	CANTILEVER DUAL TUBE	LACLEDE'S LANDING BLVD ML KING BRIDGE TO ILLINOIS	COVER THE FOLLOWING TEXT "ML KING BRIDGE TO ILLINOIS"	FULL CLOSURE WITH EB DETOUR
12 (LEFT SIGN)	ON CONVENTION PLAZA	STRUCTURE MOUNTED	3RD ST ML KING BRIDGE TO ILLINOIS	COVER THE FOLLOWING TEXT "ML KING BRIDGE TO ILLINOIS"	FULL CLOSURE WITH EB DETOUR
12 (MIDDLE SIGN)	ON CONVENTION PLAZA	STRUCTURE MOUNTED	ML KING BRIDGE TO ILLINOIS	PLACE "CLOSED" PLAQUE OVER	FULL CLOSURE WITH EB DETOUR
13 (LEFT SIGN)	AT EB ENTRANCE TO MLK BRIDGE	DUAL TUBE BUTTERFLY	ML KING BRIDGE TO ILLINOIS	PLACE "CLOSED" PLAQUE OVER	FULL CLOSURE WITH EB DETOUR
14 (RIGHT SIGN)	MORGAN ST.	STRUCTURE MOUNTED	EAST 44 TO 70 ML KING BRIDGE	COVER THE FOLLOWING TEXT "ML KING BRIDGE"	FULL CLOSURE WITH EB DETOUR

TOTAL NUMBER OF "CLOSED" SIGNS IN MISSOURI = 4

TOTAL NUMBER OF SIGNS TO BE COVERED IN MISSOURI = 11

COST OF MODIFYING EXISTING GREENBOARD SIGNS TO BE INCLUDED IN THE COST OF THE PAY ITEM FOR TRAFFIC CONTROL AND PROTECTION, (SPECIAL).

FILE NAME *	USER NAME * haydend	DESIGNED -	REVISED -	STATE OF ILLINOIS DEPARTMENT OF TRANSPORTATION	TRAFFIC CONTROL PROTECTION PLAN SCHEDULES			F.A.P. RTE.	SECTION	COUNTY	TOTAL SHEETS	SHEET NO.
est:\pwork\pwork\haydend\dm52153\0876-93-ahtrating.dgn	PLOT SCALE * 100.0000' / in.	DRAWN -	REVISED -					799	IBR, DRS-2	ST. CLAIR	156	9
PLOT DATE * 9/26/2014	DATE -	CHECKED -	REVISED -		SCALE: _____ SHEET NO. 3 OF 20 SHEETS STA. _____ TO STA. _____			CONTRACT NO. 76803				
					FED. ROAD DIST. NO. ILLINOIS FED. AID PROJECT							

CHANGEABLE MESSAGE SIGN								
SIGN NUMBER	LOCATION	PRE-CLOSURE PHASE (NIGHTLY EB CLOSURE OF MLK)		COMPLETE CLOSURE PHASE (EB AND WB MLK CLOSED)		POST-CLOSURE PHASE (NIGHTLY EB CLOSURE OF MLK)		CALENDAR MONTHS
		2 WEEKS IN ADVANCE	DURING NIGHTLY EB CLOSURES	2 WEEKS IN ADVANCE	DURING CLOSURE	2 WEEKS IN ADVANCE	DURING NIGHTLY EB CLOSURES	
1	ALONG I-70 EB IN ST. LOUIS	X	X	X	X	X	X	15
2	AT ENTRANCE TO EB MLK IN ST. LOUIS	X	X	X	X	X	X	15
3	ALONG I-55 SB / I-70 WB IN ILLINOIS			X	X			6
4	ALONG I-64 WB IN ILLINOIS			X	X			6
5	AT ENTRANCE TO WB MLK IN EAST ST. LOUIS			X				1
6	ALONG I-55 SB / I-64 WB IN ILLINOIS			X				1
TOTAL CALENDAR MONTHS								44

SEE DETOUR PLAN SHEET FOR APPROXIMATE LOCATIONS

TRAFFIC CONTROL SCHEDULE									
LOCATION	PAVEMENT MARKING TAPE, TYPE III				PAVEMENT MARKING BLACKOUT TAPE		WORK ZONE PAVEMENT MARKING REMOVAL	TEMPORARY CONCRETE BARRIER	IMPACT ATTENUATORS, TEMPORARY (NON-REDIRECTIVE, NARROW), TEST LEVEL 3
	5" EDGELINE YELLOW	8" EDGELINE WHITE	GORE		9" EDGELINE	5" SKIP-DASH			
			8" EDGELINE WHITE	12" CHEVRONS WHITE					
FOOT	FOOT	FOOT	FOOT	FOOT	FOOT	SO FT	FOOT	EACH	
I-55 SB TRI-LEVEL		595.5					397		
I-64 WB/ I-55 SB	1500.3					210.0	712.6		
I-64 WB/ I-55 SB ON-RAMP ("RAMP I")	1173.7		1254.2	270.9	224.7	186**	1842.0		
RIGHT WB MLK BRIDGE APPROACH								2312.5	1
LEFT WB MLK BRIDGE APPROACH								725	1
PERPENDICULAR TCB FOR STRUCTURE CLOSURE								112.5	
TOTALS	2674	595.5	1254.2	270.9	224.7	396	2951.6	3150.0	2
		1849.7							



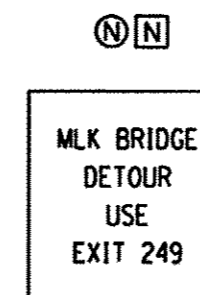
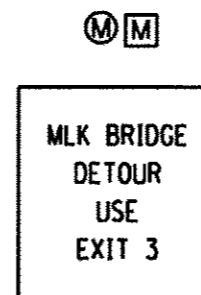
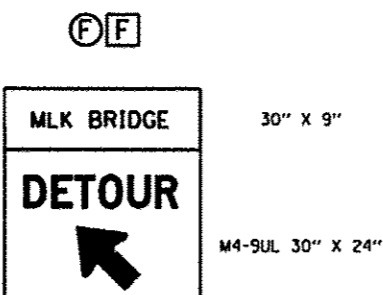
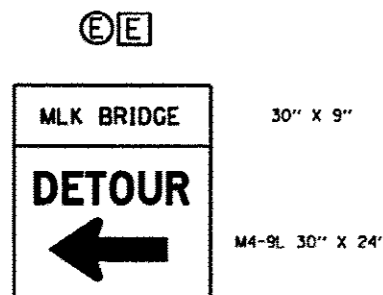
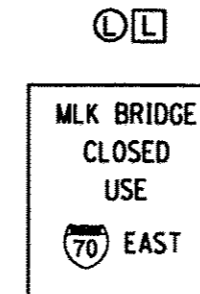
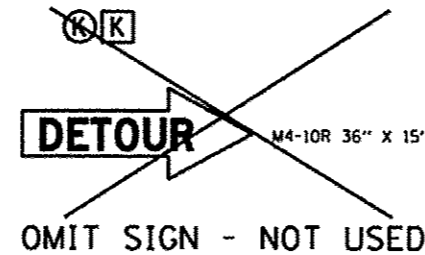
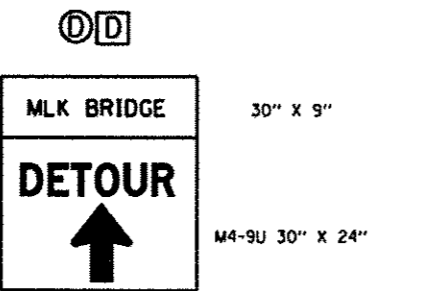
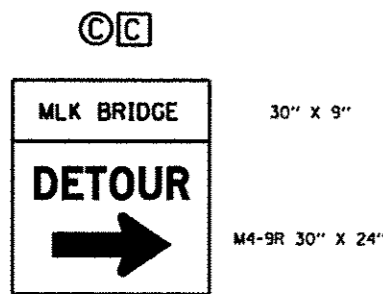
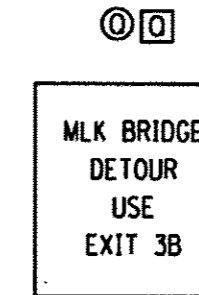
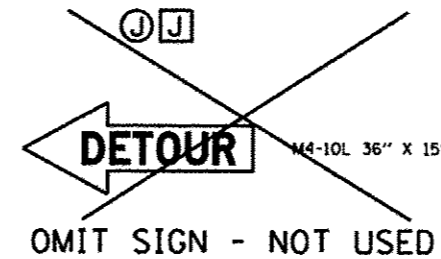
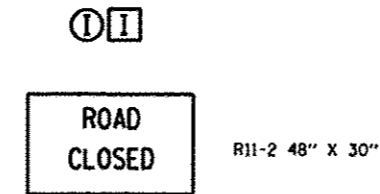
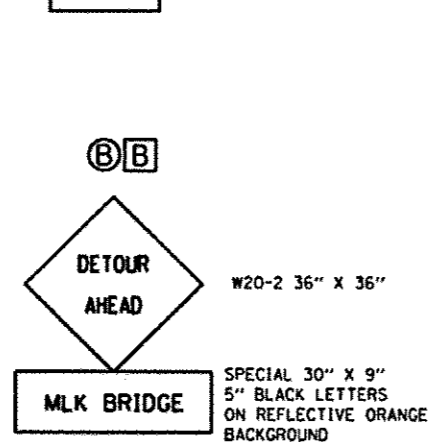
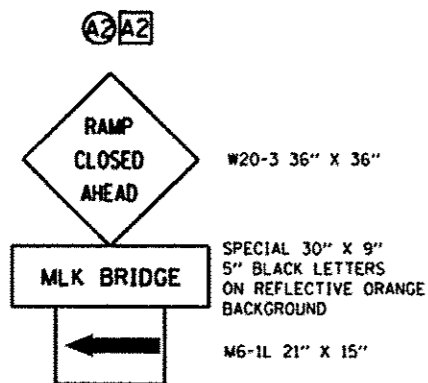
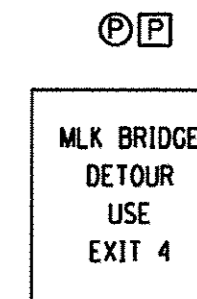
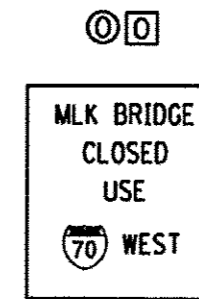
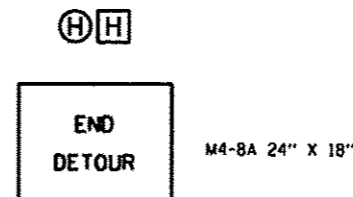
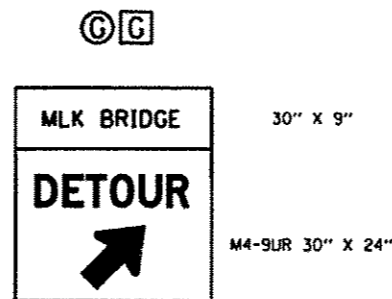
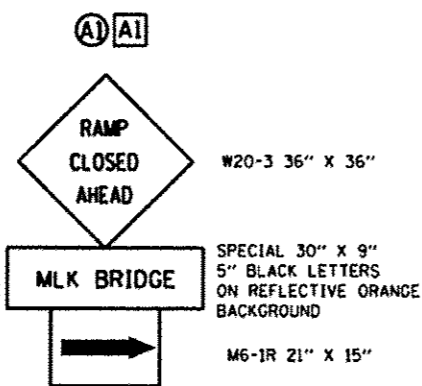
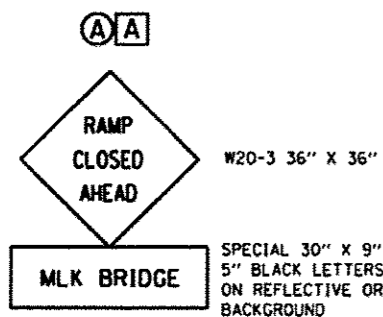

** INCLUDES QUANTITY FOR BLACKOUT OF RAISED REFLECTORS

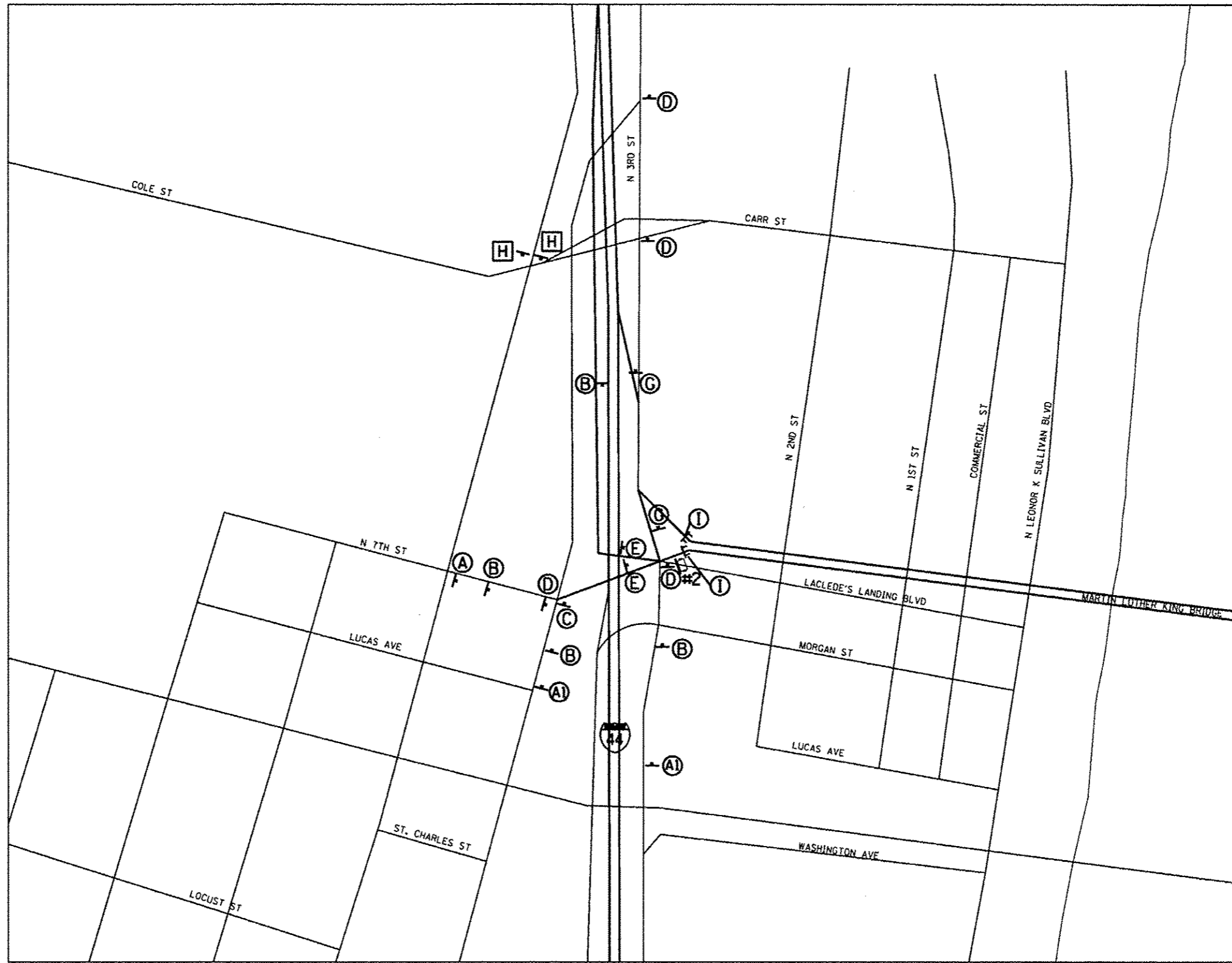

- LEGEND:
- SIGN
 - TYPE III BARRICADE
 - CHANGEABLE MESSAGE SIGN
 - EASTBOUND DETOUR SIGNING
 - WESTBOUND DETOUR SIGNING







NOT TO SCALE

- LEGEND:**
-  SIGN
 -  TYPE III BARRICADE
 -  CHANGEABLE MESSAGE SIGN
 -  EASTBOUND DETOUR SIGNING
 -  WESTBOUND DETOUR SIGNING

FILE NAME * c:\p\work\p\dot\heydend\idea52153\0676	USER NAME * heydend	DESIGNED -	REVISED -	STATE OF ILLINOIS DEPARTMENT OF TRANSPORTATION	TRAFFIC CONTROL PROTECTION PLAN DETOUR PLAN SHEET 1			F.A.P. RTE. 799	SECTION IBR, DRS-2	COUNTY ST. CLAIR	TOTAL SHEETS 156	SHEET NO. 12
	PLOT SCALE * 1/8"=1'-0"	DRAWN -	REVISED -		SCALE: _____	SHEET NO. 6 OF 20 SHEETS	STA. _____ TO STA. _____	FED. ROAD DIST. NO. _____ (ILLINOIS) FED. AID PROJECT				
PLOT DATE * 9/26/2014	CHECKED -	REVISED -	CONTRACT NO. 76B03									
	DATE -	REVISED -										



- LEGEND:
-  SIGN
 -  TYPE III BARRICADE
 -  CHANGEABLE MESSAGE SIGN
 -  EASTBOUND DETOUR SIGNING
 -  WESTBOUND DETOUR SIGNING

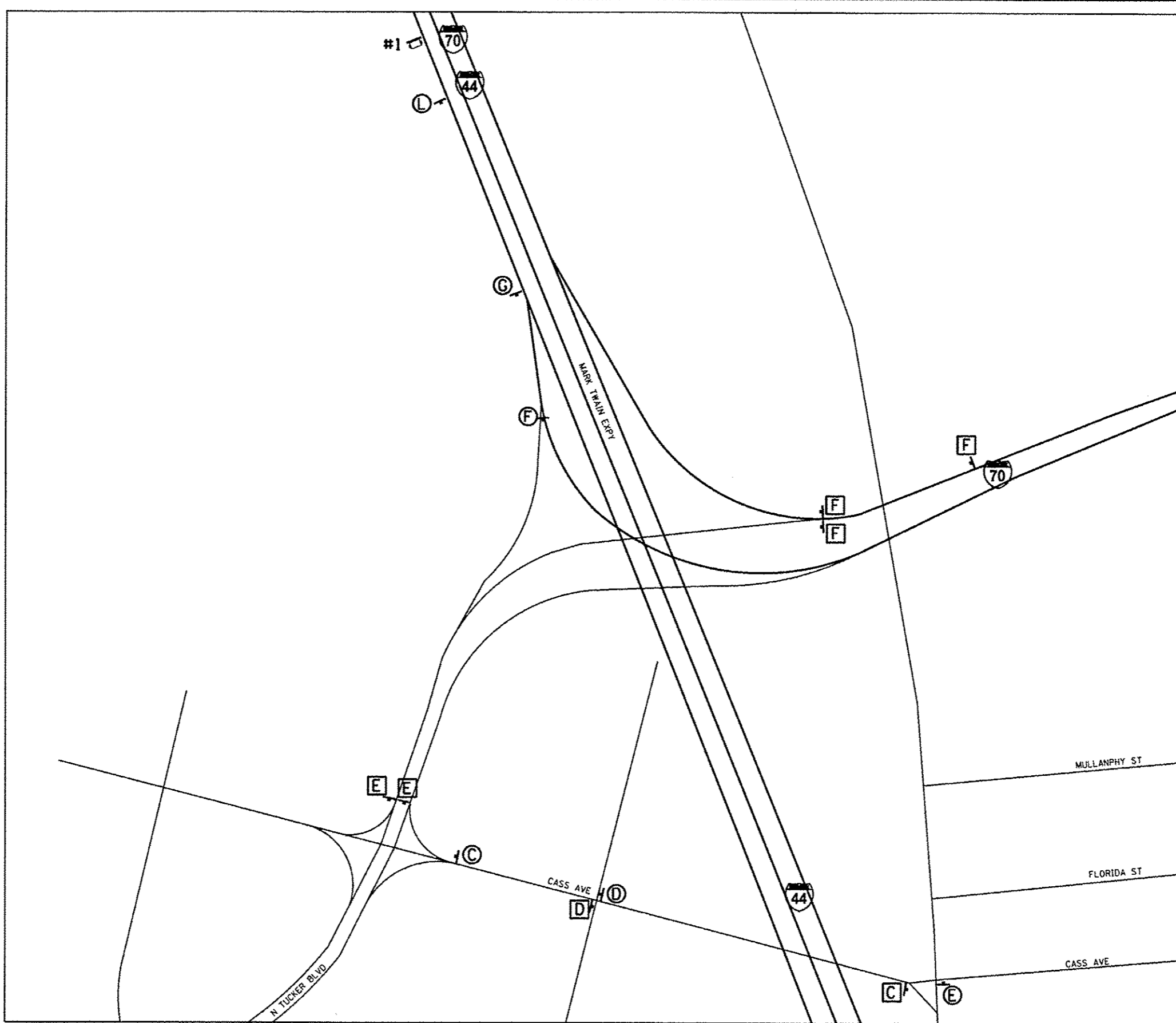

NOT TO SCALE

FILE NAME *	USER NAME * haydend	DESIGNED -	REVISED -	STATE OF ILLINOIS DEPARTMENT OF TRANSPORTATION	TRAFFIC CONTROL PROTECTION PLAN DETOUR PLAN SHEET 2	F.A.P. RTE.	SECTION	COUNTY	TOTAL SHEETS	SHEET NO.	
ca:\pwwork\pwwork\dot\haydend\idms52153\0876	83-ah1-a1eging.dgn	DRAWN -	REVISED -			799	IBR, DRS-2	ST. CLAIR	156	13	
	PLOT SCALE * 100.0000' / 1" =	CHECKED -	REVISED -			CONTRACT NO. 76803					
	PLOT DATE * 9/26/2014	DATE -	REVISED -			FED. ROAD DIST. NO. - ILLINOIS FED. AID PROJECT					

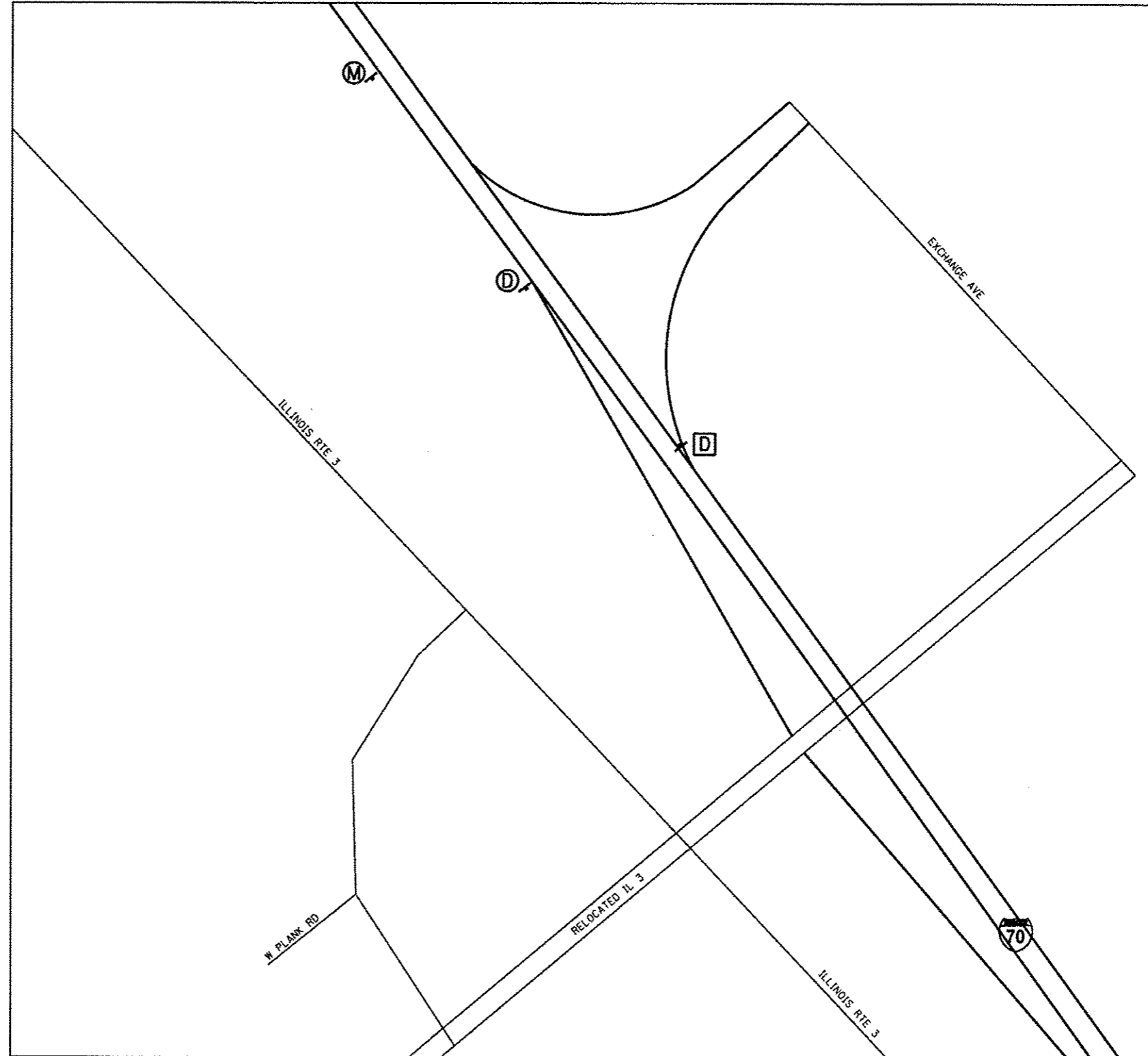





- LEGEND:
- SIGN
 - TYPE III BARRICADE
 - CHANGEABLE MESSAGE SIGN
 - EASTBOUND DETOUR SIGNING
 - WESTBOUND DETOUR SIGNING

NOT TO SCALE

FILE NAME *	USER NAME * haydend	DESIGNED -	REVISED -	STATE OF ILLINOIS DEPARTMENT OF TRANSPORTATION	TRAFFIC CONTROL PROTECTION PLAN DETOUR PLAN SHEET 3			F.A.P. RTE.	SECTION	COUNTY	TOTAL SHEETS	SHEET NO.
ca:\p_w\work\p\p\dot\haydend\des\2153\0876	83-shi-a-leging-dgn	DRAWN -	REVISED -		799	IBR, ORS-2	ST. CLAIR	156	14			
	PLOT SCALE * 100.0000' / 1"	CHECKED -	REVISED -		CONTRACT NO. 76B03							
	PLOT DATE * 9/26/2014	DATE -	REVISED -		FED. ROAD DIST. NO. (ILLINOIS) FED. AID PROJECT							
				SCALE:	SHEET NO. 8 OF 20 SHEETS	STA.	TO STA.					

LEGEND:



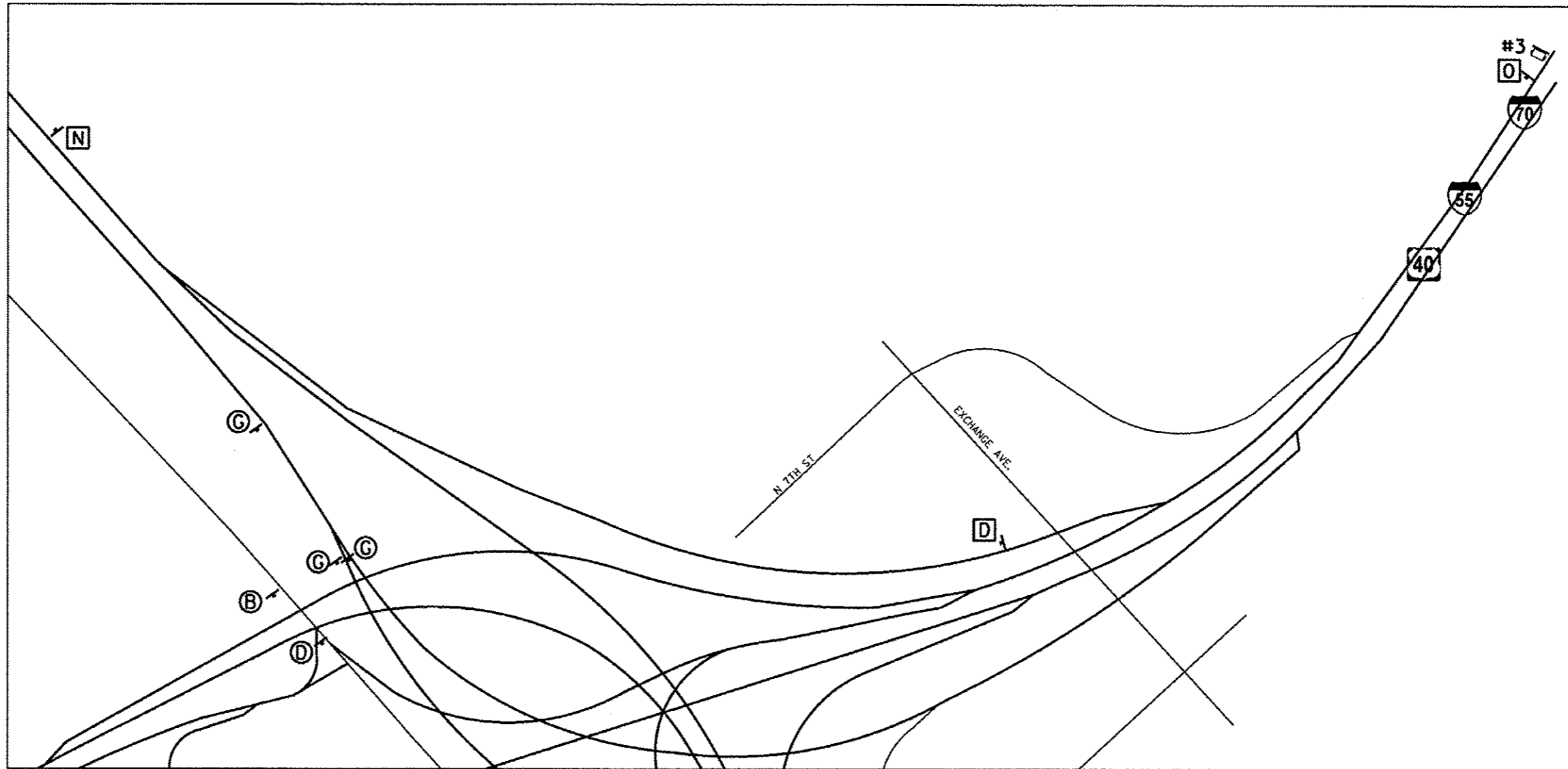

-  SIGN
-  TYPE III BARRICADE
-  CHANGEABLE MESSAGE SIGN
-  EASTBOUND DETOUR SIGNING
-  WESTBOUND DETOUR SIGNING

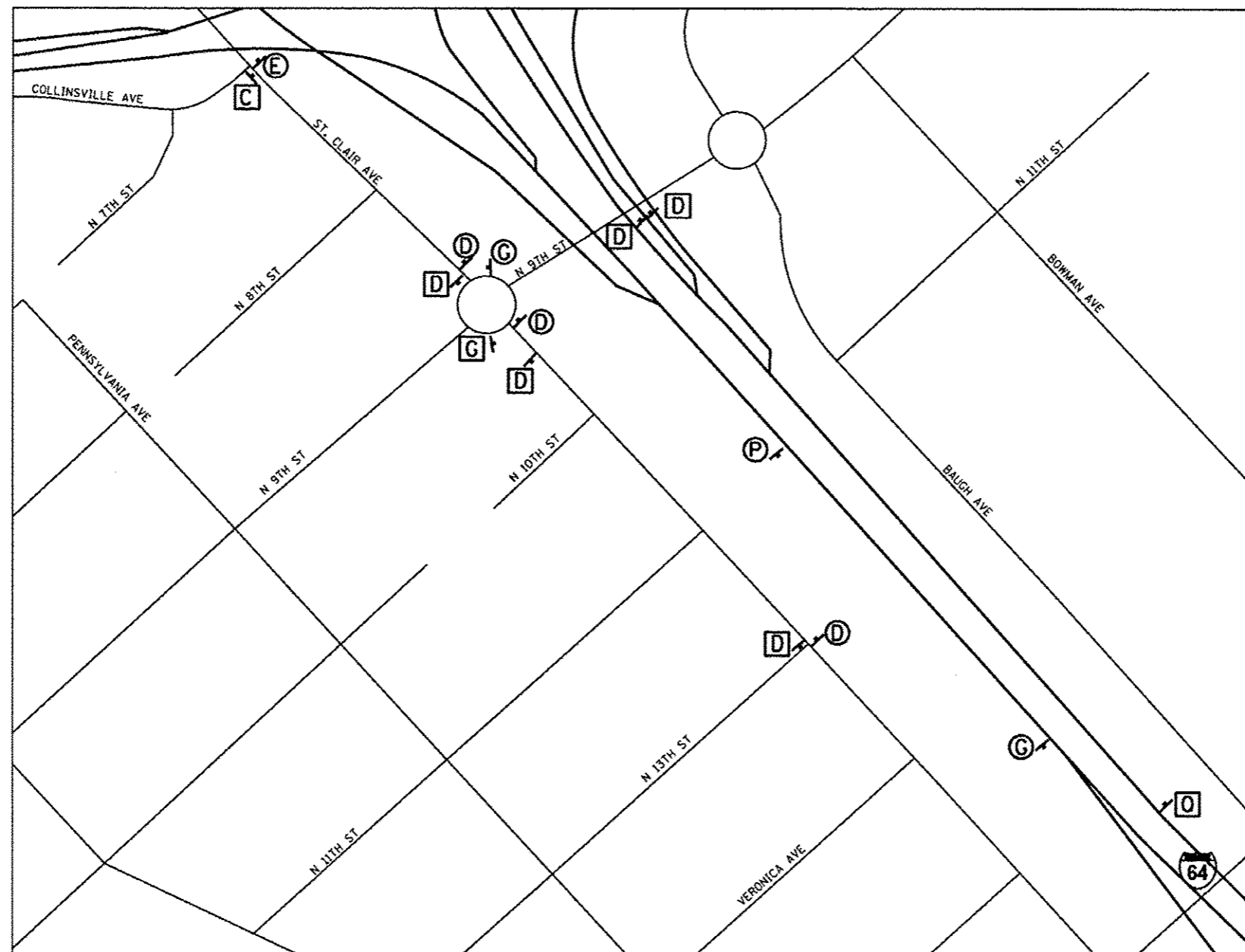

NOT TO SCALE

FILE NAME *	USER NAME * haydend	DESIGNED -	REVISED -	STATE OF ILLINOIS DEPARTMENT OF TRANSPORTATION	TRAFFIC CONTROL PROTECTION PLAN DETOUR PLAN SHEET 4	F.A.P. RTE.	SECTION	COUNTY	TOTAL SHEETS	SHEET NO.	
cs:\pwwork\pwwork\dot\haydend\dms52153\0876	03-ah1-a\taging.dgn	DRAWN -	REVISED -			799	1BR, DRS-2	ST. CLAIR	156	15	
PLOT SCALE * 1/8"=1'-0"	CHECKED -	REVISED -	REVISED -			CONTRACT NO. 76B03					
PLOT DATE * 9/26/2014	DATE -	REVISED -	REVISED -			FED. ROAD DIST. NO. ILLINOIS FED. AID PROJECT					





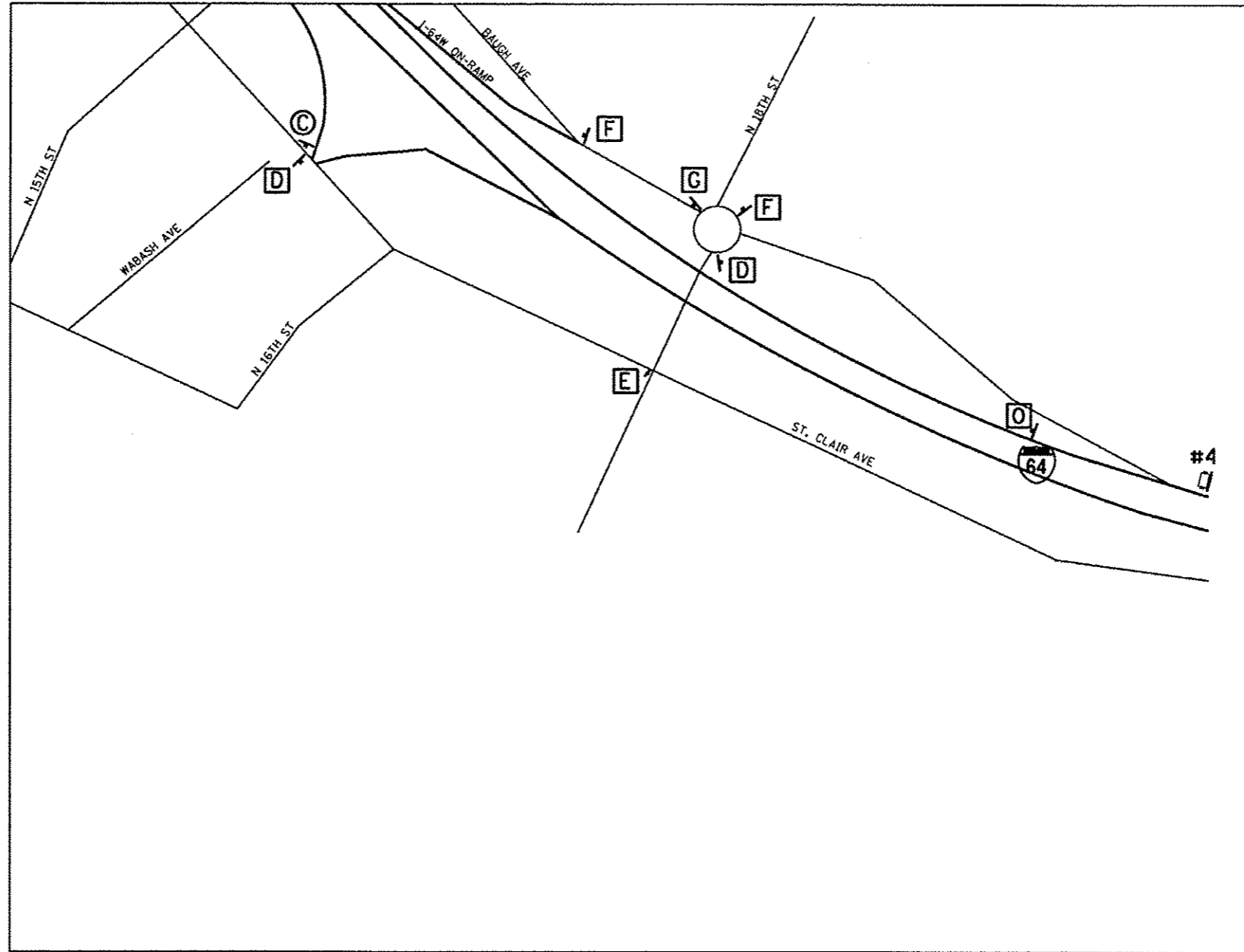

- LEGEND:
-  SIGN
 -  TYPE III BARRICADE
 -  CHANGEABLE MESSAGE SIGN
 -  EASTBOUND DETOUR SIGNING
 -  WESTBOUND DETOUR SIGNING

NOT TO SCALE

FILE NAME *	USER NAME * haydend	DESIGNED -	REVISED -	STATE OF ILLINOIS DEPARTMENT OF TRANSPORTATION	TRAFFIC CONTROL PROTECTION PLAN DETOUR PLAN SHEET 5		F.A.P. RTE.	SECTION	COUNTY	TOTAL SHEETS	SHEET NO.
	ca:\pwork\p1\dot\haydend\des521531\0876\03-ah1-e-tagging.dgn	DRAWN -	REVISED -				799	IBR, DRS-2	ST. CLAIR	156	16
	PLOT SCALE * 100.0000' / 1"	CHECKED -	REVISED -		SCALE: _____	SHEET NO. 10 OF 20 SHEETS	STA. _____	TO STA. _____	CONTRACT NO. 76803		
	PLOT DATE * 9/26/2014	DATE -	REVISED -		FED. ROAD DIST. NO. _____ ILLINOIS FED. AID PROJECT						



- LEGEND:
-  SIGN
 -  TYPE III BARRICADE
 -  CHANGEABLE MESSAGE SIGN
 -  EASTBOUND DETOUR SIGNING
 -  WESTBOUND DETOUR SIGNING

NOT TO SCALE

FILE NAME *	USER NAME * haydend	DESIGNED -	REVISED -	STATE OF ILLINOIS DEPARTMENT OF TRANSPORTATION	TRAFFIC CONTROL PROTECTION PLAN DETOUR PLAN SHEET 6		F.A.P. RTE.	SECTION	COUNTY	TOTAL SHEETS	SHEET NO.
ca:\pwwork\psidot\haydend\idms3215310876	93-ah1-e-tagimg.dgn	DRAWN -	REVISED -		799	IBR, DRS-2	ST. CLAIR	156	17		
	PLOT SCALE * 100.0000' / 1" =	CHECKED -	REVISED -		SCALE: _____ SHEET NO. 11 OF 20 SHEETS STA. _____ TO STA. _____			CONTRACT NO. 76803			
	PLOT DATE * 9/26/2014	DATE -	REVISED -		FED. ROAD DIST. NO. - [ILLINOIS] FED. AID PROJECT						

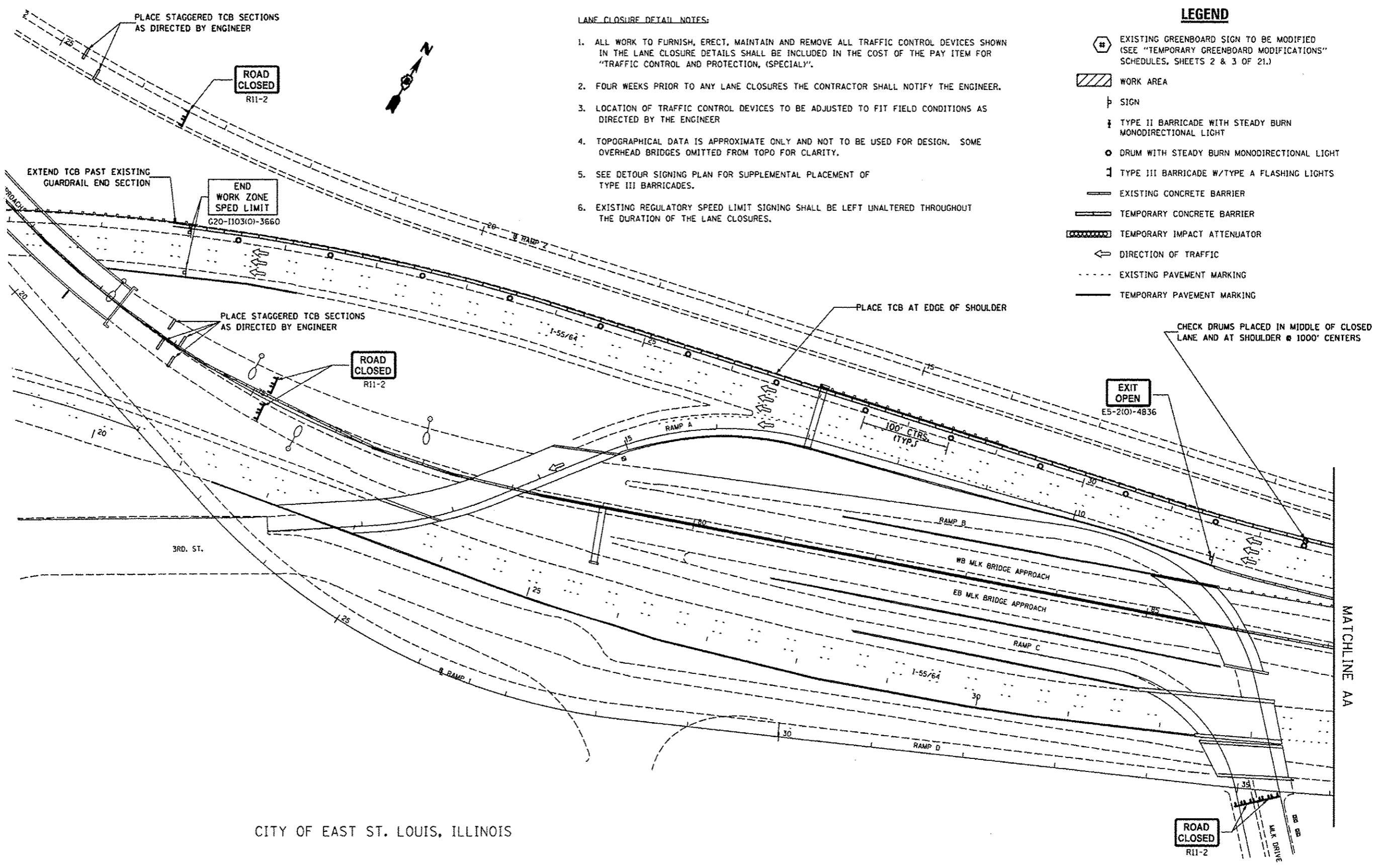

LANE CLOSURE DETAIL NOTES:

1. ALL WORK TO FURNISH, ERECT, MAINTAIN AND REMOVE ALL TRAFFIC CONTROL DEVICES SHOWN IN THE LANE CLOSURE DETAILS SHALL BE INCLUDED IN THE COST OF THE PAY ITEM FOR "TRAFFIC CONTROL AND PROTECTION, (SPECIAL)".
2. FOUR WEEKS PRIOR TO ANY LANE CLOSURES THE CONTRACTOR SHALL NOTIFY THE ENGINEER.
3. LOCATION OF TRAFFIC CONTROL DEVICES TO BE ADJUSTED TO FIT FIELD CONDITIONS AS DIRECTED BY THE ENGINEER
4. TOPOGRAPHICAL DATA IS APPROXIMATE ONLY AND NOT TO BE USED FOR DESIGN. SOME OVERHEAD BRIDGES OMITTED FROM TOPO FOR CLARITY.
5. SEE DETOUR SIGNING PLAN FOR SUPPLEMENTAL PLACEMENT OF TYPE III BARRICADES.
6. EXISTING REGULATORY SPEED LIMIT SIGNING SHALL BE LEFT UNALTERED THROUGHOUT THE DURATION OF THE LANE CLOSURES.

LEGEND

- ⊠ EXISTING GREENBOARD SIGN TO BE MODIFIED (SEE "TEMPORARY GREENBOARD MODIFICATIONS" SCHEDULES, SHEETS 2 & 3 OF 21.)
- ▨ WORK AREA
- ⊥ SIGN
- ⊥ TYPE II BARRICADE WITH STEADY BURN MONODIRECTIONAL LIGHT
- DRUM WITH STEADY BURN MONODIRECTIONAL LIGHT
- ⊥ TYPE III BARRICADE W/TYP A FLASHING LIGHTS
- EXISTING CONCRETE BARRIER
- TEMPORARY CONCRETE BARRIER
- ▬ TEMPORARY IMPACT ATTENUATOR
- ⇐ DIRECTION OF TRAFFIC
- EXISTING PAVEMENT MARKING
- TEMPORARY PAVEMENT MARKING

CITY OF EAST ST. LOUIS, ILLINOIS

MATCHLINE AA

FILE NAME *	USER NAME *	DESIGNED -	REVISED -	STATE OF ILLINOIS DEPARTMENT OF TRANSPORTATION	TRAFFIC CONTROL PROTECTION PLAN LANE CLOSURE DETAILS AND EXISTING SIGN MODIFICATION PLAN	F.A.P. RTE.	SECTION	COUNTY	TOTAL SHEETS	SHEET NO.	
es:\pwork\psidot\hayden\dm52153\0876	83-ah-tracing-lane_closures.dgn	DRAWN -	REVISED -			799	1BR, DRS-2	ST. CLAIR	156	18A	
	PLOT SCALE * 100.0000 / / in.	CHECKED -	REVISED -			SCALE: N.T.S.		SHEET NO. 13 OF 20 SHEETS		STA. _____ TO STA. _____	FED. ROAD DIST. NO. _____ ILLINOIS FED. AID PROJECT
	PLOT DATE * 9/26/2014	DATE -	REVISED -			CONTRACT NO. 76803					

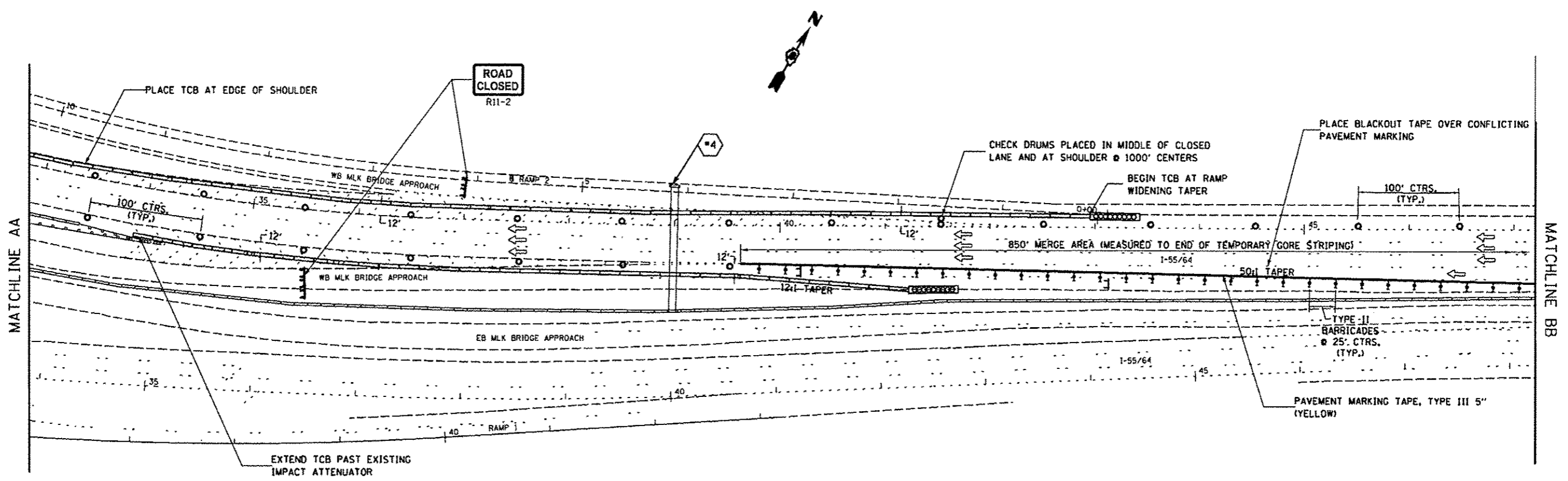

LEGEND

- # EXISTING GREENBOARD SIGN TO BE MODIFIED (SEE "TEMPORARY GREENBOARD MODIFICATIONS" SCHEDULES, SHEETS 2 & 3 OF 21.)
- ▨ WORK AREA
- ⊥ SIGN
- ⊥ TYPE II BARRICADE WITH STEADY BURN MONODIRECTIONAL LIGHT
- DRUM WITH STEADY BURN MONODIRECTIONAL LIGHT
- ⊥ TYPE III BARRICADE W/ TYPE A FLASHING LIGHTS
- EXISTING CONCRETE BARRIER
- TEMPORARY CONCRETE BARRIER
- ▬ TEMPORARY IMPACT ATTENUATOR
- ↔ DIRECTION OF TRAFFIC
- - - - EXISTING PAVEMENT MARKING
- TEMPORARY PAVEMENT MARKING

CITY OF EAST ST. LOUIS, ILLINOIS

FILE NAME * c:\p\work\p\dot\shayden\idea52153\0876	USER NAME * hayden 83-sh-lane-closure.dgn	DESIGNED - _____ DRAWN - _____	REVISED - _____ REVISED - _____	STATE OF ILLINOIS DEPARTMENT OF TRANSPORTATION	TRAFFIC CONTROL PROTECTION PLAN LANE CLOSURE DETAILS AND EXISTING SIGN MODIFICATION PLAN		F.A.P. RTE. 799	SECTION 1BR, DRS-2	COUNTY ST. CLAIR	TOTAL SHEETS 156	SHEET NO. 188	
	PLOT SCALE * 1/8" = 1'	CHECKED - _____	REVISED - _____		SCALE: N.T.S.	SHEET NO. 14 OF 20 SHEETS	STA. _____ TO STA. _____	FED. ROAD DIST. NO. _____ ILLINOIS FED. AID PROJECT				
	PLOT DATE * 9/26/2014	DATE - _____	REVISED - _____		CONTRACT NO. 76803							

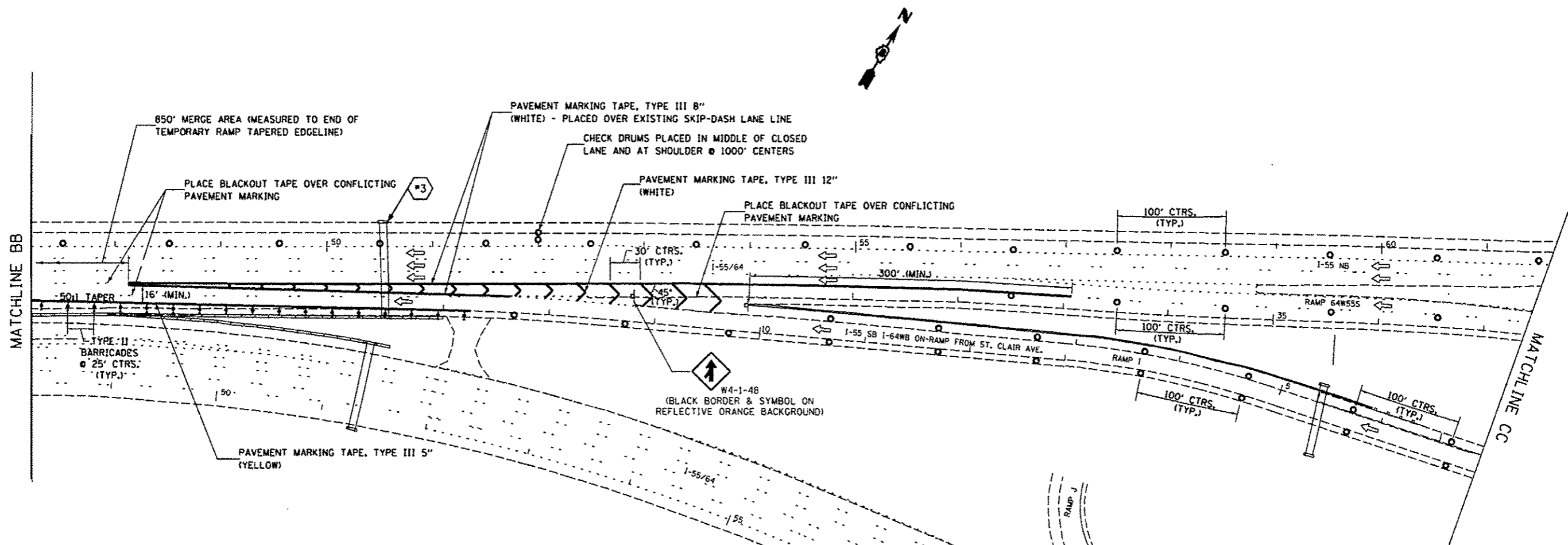

LEGEND

- EXISTING GREENBOARD SIGN TO BE MODIFIED (SEE "TEMPORARY GREENBOARD MODIFICATIONS" SCHEDULES, SHEETS 2 & 3 OF 21.)
- WORK AREA
- SIGN
- TYPE II BARRICADE WITH STEADY BURN MONODIRECTIONAL LIGHT
- DRUM WITH STEADY BURN MONODIRECTIONAL LIGHT
- TYPE III BARRICADE W/ TYPE A FLASHING LIGHTS
- EXISTING CONCRETE BARRIER
- TEMPORARY CONCRETE BARRIER
- TEMPORARY IMPACT ATTENUATOR
- DIRECTION OF TRAFFIC
- EXISTING PAVEMENT MARKING
- TEMPORARY PAVEMENT MARKING

CITY OF EAST ST. LOUIS, ILLINOIS

FILE NAME * c:\p\work\p\dot\hagdend\dms52153\0876	USER NAME * hagdend	DESIGNED -	REVISED -	STATE OF ILLINOIS DEPARTMENT OF TRANSPORTATION	TRAFFIC CONTROL PROTECTION PLAN LANE CLOSURE DETAILS AND EXISTING SIGN MODIFICATION PLAN		F.A.P. RTE.	SECTION	COUNTY	TOTAL SHEETS	SHEET NO.
	193-eh-t-staging-lane-closure.sgn	DRAWN -	REVISED -				799	IBR, ORS-2	ST. CLAIR	156	18C
PLOT SCALE * 100.0000' / 1" =	CHECKED -	REVISED -	REVISED -	SCALE: N.T.S. SHEET NO. 15 OF 20 SHEETS STA. TO STA.		CONTRACT NO. 76803		FED. ROAD DIST. NO. ILLINOIS FED. AID PROJECT			
PLOT DATE * 9/26/2014	DATE -	REVISED -	REVISED -								

LEGEND

- ⊠ # EXISTING GREENBOARD SIGN TO BE MODIFIED (SEE "TEMPORARY GREENBOARD MODIFICATIONS" SCHEDULES, SHEETS 2 & 3 OF 21.)
- ▨ WORK AREA
- ⊥ SIGN
- ⊥ TYPE II BARRICADE WITH STEADY BURN MONODIRECTIONAL LIGHT
- DRUM WITH STEADY BURN MONODIRECTIONAL LIGHT
- ⊥ TYPE III BARRICADE W/ TYPE A FLASHING LIGHTS
- EXISTING CONCRETE BARRIER
- TEMPORARY CONCRETE BARRIER
- ▬ TEMPORARY IMPACT ATTENUATOR
- ← DIRECTION OF TRAFFIC
- - - EXISTING PAVEMENT MARKING
- TEMPORARY PAVEMENT MARKING

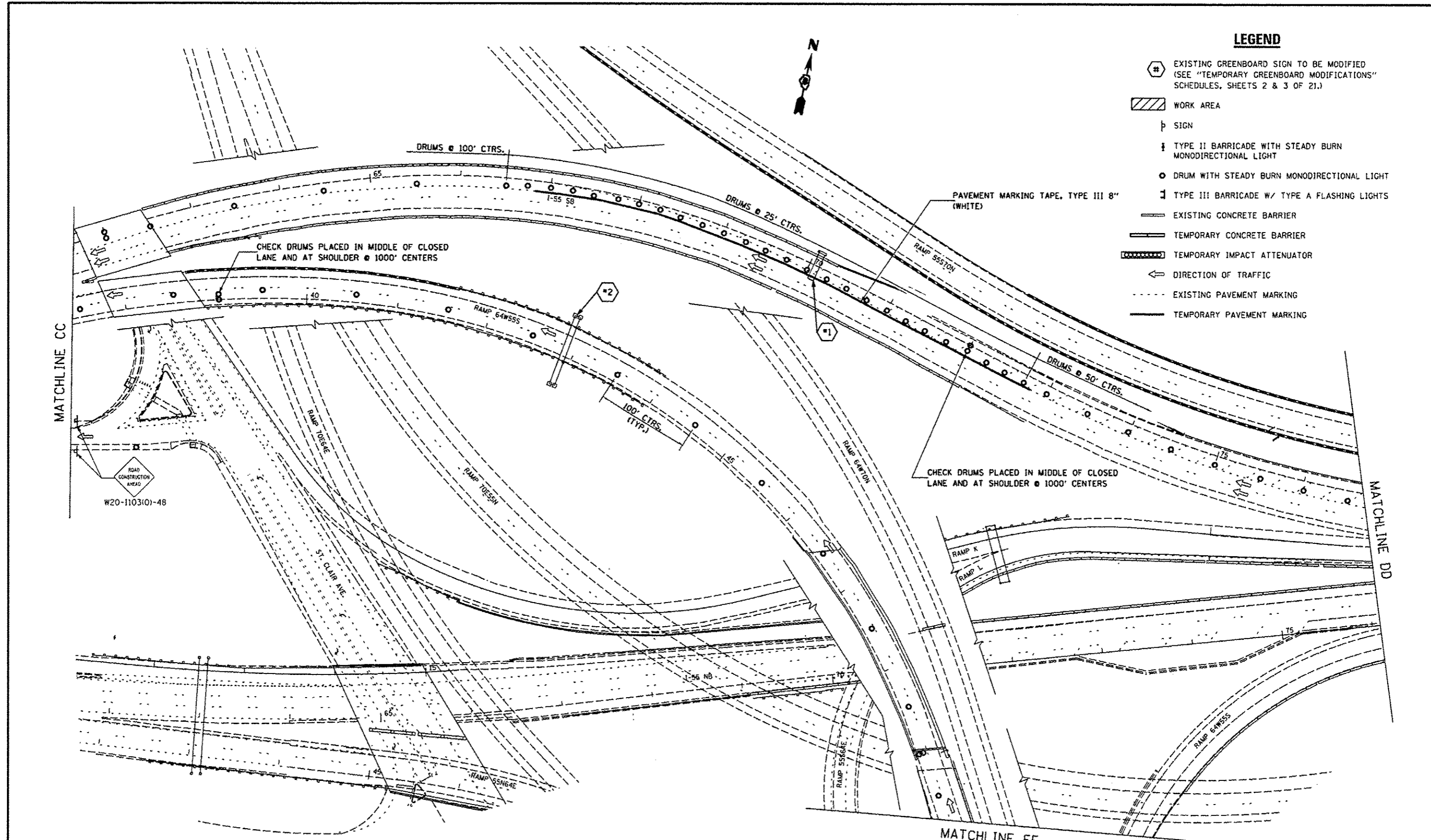

CITY OF EAST ST. LOUIS, ILLINOIS

FILE NAME *	USER NAME * haydend	DESIGNED -	REVISED -	STATE OF ILLINOIS DEPARTMENT OF TRANSPORTATION	TRAFFIC CONTROL PROTECTION PLAN LANE CLOSURE DETAILS AND EXISTING SIGN MODIFICATION PLAN		F.A.P. RTE.	SECTION	COUNTY	TOTAL SHEETS	SHEET NO.
g:\p\work\p\dot\haydend\des\52153\0876\83-ah-t-staging-lane-closure.dgn		DRAWN -	REVISED -		799	1BR, DRS-2	ST. CLAIR	156	180		
PLOT SCALE * 100.0000 / in.		CHECKED -	REVISED -		SCALE: N.T.S. SHEET NO. 16 OF 20 SHEETS STA. TO STA.		CONTRACT NO. 76B03				
PLOT DATE * 9/26/2014		DATE -	REVISED -		FED. ROAD DIST. NO. [ILLINOIS] FED. AID PROJECT						

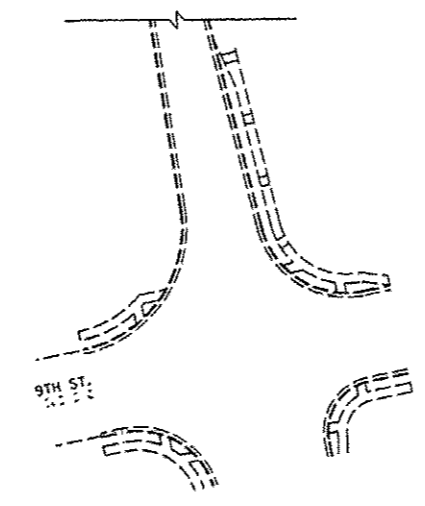
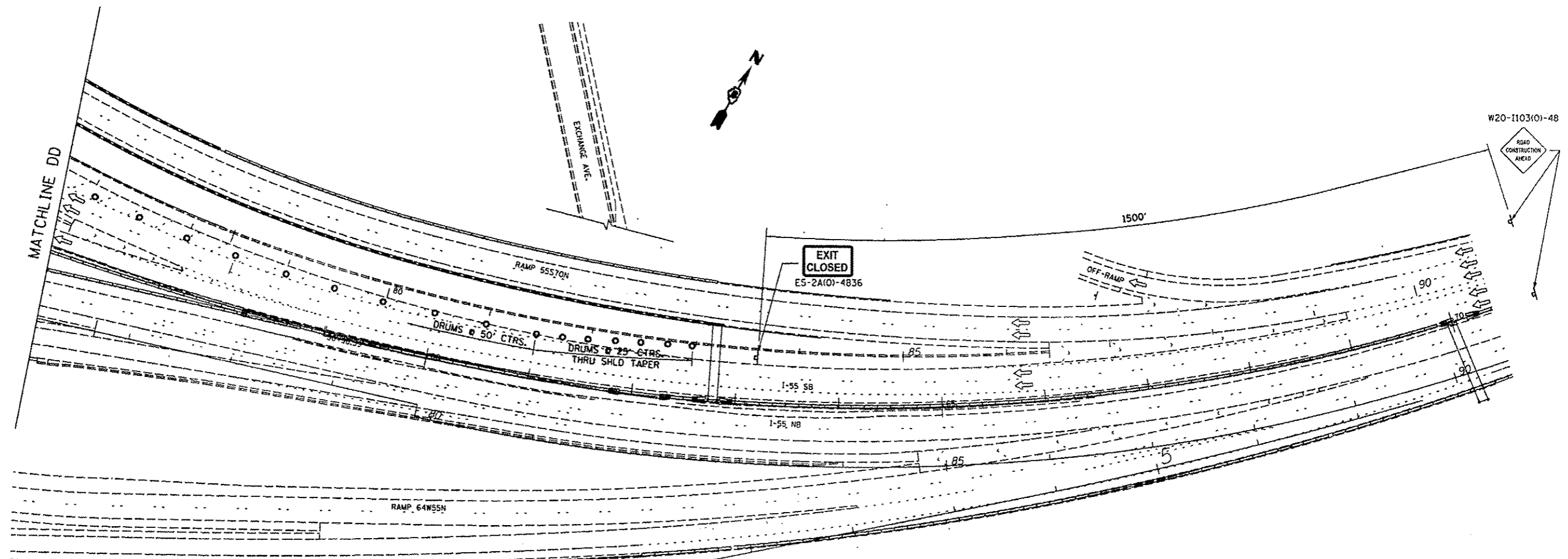

CITY OF EAST ST. LOUIS, ILLINOIS

LEGEND

- ⊛ EXISTING GREENBOARD SIGN TO BE MODIFIED (SEE "TEMPORARY GREENBOARD MODIFICATIONS" SCHEDULES, SHEETS 2 & 3 OF 21.)
- ▨ WORK AREA
- ⊥ SIGN
- ⊚ TYPE II BARRICADE WITH STEADY BURN MONODIRECTIONAL LIGHT
- ⊙ DRUM WITH STEADY BURN MONODIRECTIONAL LIGHT
- ⊚ TYPE III BARRICADE W/ TYPE A FLASHING LIGHTS
- EXISTING CONCRETE BARRIER
- TEMPORARY CONCRETE BARRIER
- ▬ TEMPORARY IMPACT ATTENUATOR
- ⇐ DIRECTION OF TRAFFIC
- ⋯ EXISTING PAVEMENT MARKING
- TEMPORARY PAVEMENT MARKING

FILE NAME *	USER NAME * haydend	DESIGNED -	REVISED -
ca:\p\work\p\dot\haydend\des\52153\0676	03-ph-t-staging-lane-02curas.dgn	DRAWN -	REVISED -
	PLOT SCALE * 1/8"=1'-0"	CHECKED -	REVISED -
	PLOT DATE * 9/26/2014	DATE -	REVISED -

**STATE OF ILLINOIS
DEPARTMENT OF TRANSPORTATION**

**TRAFFIC CONTROL PROTECTION PLAN
LANE CLOSURE DETAILS AND EXISTING SIGN MODIFICATION PLAN**

F.A.P. RTE.	SECTION	COUNTY	TOTAL SHEETS	SHEET NO.
799	1BR, DRS-2	ST. CLAIR	156	18E
CONTRACT NO. 76803				
FED. ROAD DIST. NO. [ILLINOIS] FED. AID PROJECT				

SCALE: H.T.S. SHEET NO. 17 OF 20 SHEETS STA. _____ TO STA. _____

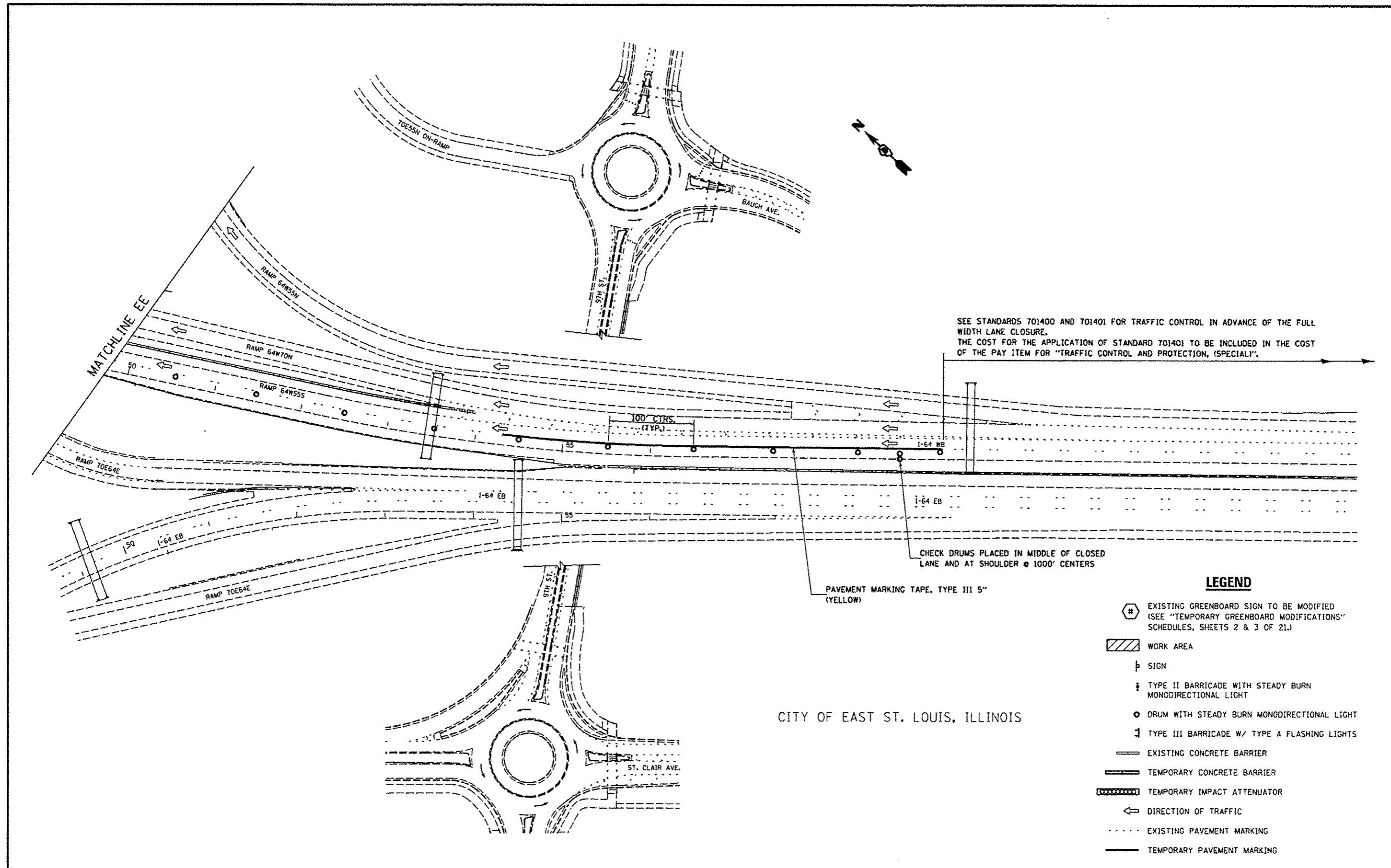

SEE STANDARDS 701400 AND 701401 FOR TRAFFIC CONTROL IN ADVANCE OF THE FULL WIDTH LANE CLOSURE. THE COST FOR THE APPLICATION OF STANDARD 701401 TO BE INCLUDED IN THE COST OF THE PAY ITEM FOR "TRAFFIC CONTROL AND PROTECTION, ISPECIALY".

CHECK DRUMS PLACED IN MIDDLE OF CLOSED LANE AND AT SHOULDER @ 1000' CENTERS

PAVEMENT MARKING TAPE, TYPE III 5" (YELLOW)

LEGEND

- # EXISTING GREENBOARD SIGN TO BE MODIFIED (SEE "TEMPORARY GREENBOARD MODIFICATIONS" SCHEDULES, SHEETS 2 & 3 OF 21.)
- ▨ WORK AREA
- ⊥ SIGN
- ⊥ TYPE II BARRICADE WITH STEADY BURN MONODIRECTIONAL LIGHT
- DRUM WITH STEADY BURN MONODIRECTIONAL LIGHT
- ⊥ TYPE III BARRICADE W/ TYPE A FLASHING LIGHTS
- EXISTING CONCRETE BARRIER
- TEMPORARY CONCRETE BARRIER
- ▬ TEMPORARY IMPACT ATTENUATOR
- ← DIRECTION OF TRAFFIC
- ⋯ EXISTING PAVEMENT MARKING
- TEMPORARY PAVEMENT MARKING

CITY OF EAST ST. LOUIS, ILLINOIS

FILE NAME *	USER NAME * haydend	DESIGNED -	REVISED -
ca:\p\work\p\dot\haydend\des5215310876	03-stg-staging-lane closure.sgn	DRAWN -	REVISED -
	PLOT SCALE * 100.0000' / in.	CHECKED -	REVISED -
	PLOT DATE * 9/26/2014	DATE -	REVISED -

**STATE OF ILLINOIS
DEPARTMENT OF TRANSPORTATION**

**TRAFFIC CONTROL PROTECTION PLAN
LANE CLOSURE DETAILS AND EXISTING SIGN MODIFICATION PLAN**

SCALE: N.T.S. SHEET NO. 18 OF 20 SHEETS STA. TO STA.

F.A.P. RTE.	SECTION	COUNTY	TOTAL SHEETS	SHEET NO.
799	1BR, DRS-2	ST. CLAIR	156	18F
CONTRACT NO. 76803				
FED. ROAD DIST. NO. ILLINOIS FED. AID PROJECT				



CITY OF ST. LOUIS, MISSOURI

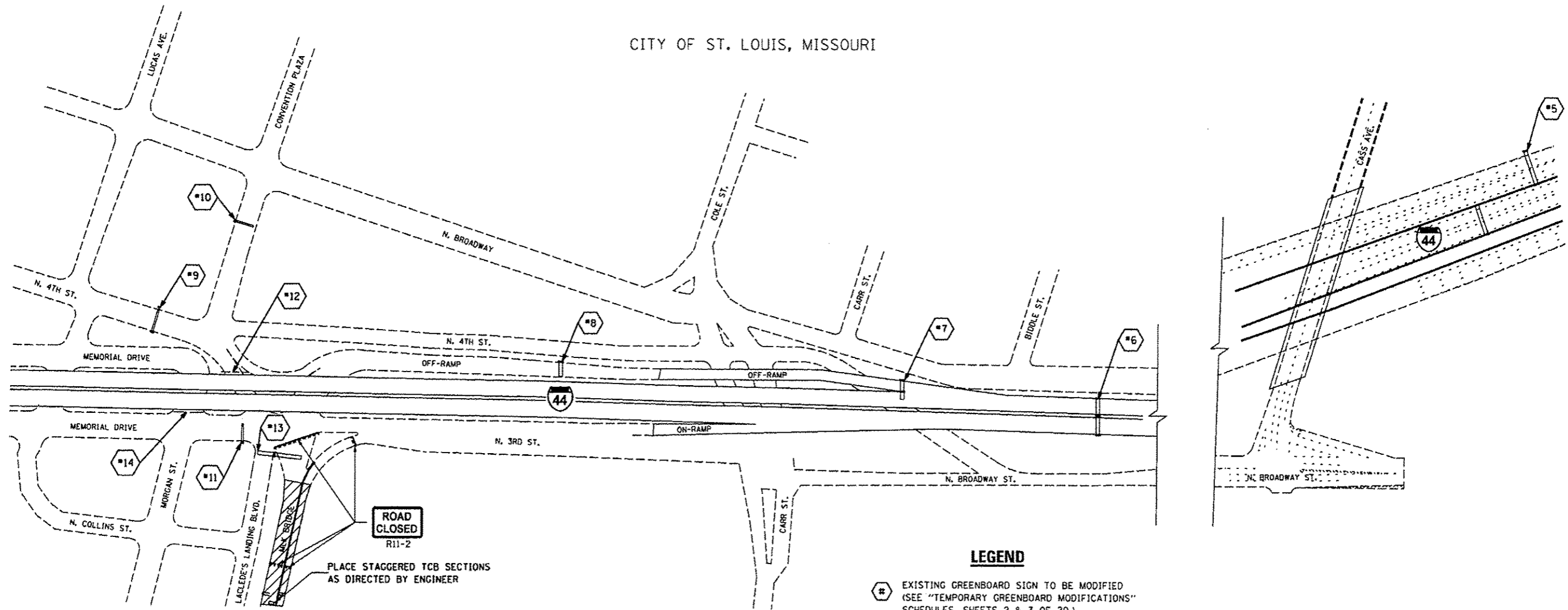

LEGEND

- ⊛ EXISTING GREENBOARD SIGN TO BE MODIFIED (SEE "TEMPORARY GREENBOARD MODIFICATIONS" SCHEDULES, SHEETS 2 & 3 OF 20.)
- ▨ WORK AREA
- ⊥ SIGN
- ⊥ TYPE II BARRICADE WITH STEADY BURN MONODIRECTIONAL LIGHT
- ⊙ DRUM WITH STEADY BURN MONODIRECTIONAL LIGHT
- ⊥ TYPE III BARRICADE W/ TYPE A FLASHING LIGHTS
- EXISTING CONCRETE BARRIER
- TEMPORARY CONCRETE BARRIER
- ⊠ TEMPORARY IMPACT ATTENUATOR
- ⇐ DIRECTION OF TRAFFIC
- - - - EXISTING PAVEMENT MARKING
- TEMPORARY PAVEMENT MARKING

FILE NAME *	USER NAME * haydend	DESIGNED -	REVISED -
ca:\pwork\psidat\haydend\dms521531\0876	03-ah-staging-lane-closure.dgn	DRAWN -	REVISED -
	PLOT SCALE * 100.0000 / in.	CHECKED -	REVISED -
	PLOT DATE * 9/26/2014	DATE -	REVISED -

STATE OF ILLINOIS
DEPARTMENT OF TRANSPORTATION

TRAFFIC CONTROL PROTECTION PLAN
EXISTING SIGN MODIFICATION PLAN

SCALE: N.T.S. SHEET NO. 19 OF 20 SHEETS STA. _____ TO STA. _____

F.A.P. RTE.	SECTION	COUNTY	TOTAL SHEETS	SHEET NO.
799	1BR, DR5-2	ST. CLAIR	156	18C
CONTRACT NO. 76803				
FED. ROAD DIST. NO. - (ILLINOIS) FED. AID PROJECT				

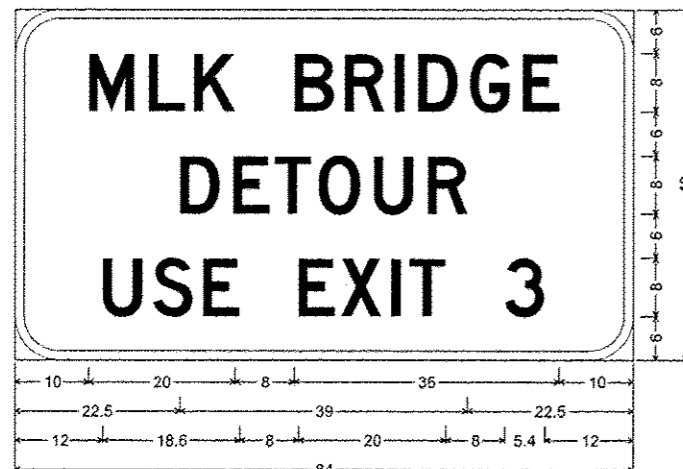

6.0" Radius, 1.3" Border, Black on Orange;
[MLK BRIDGE] D 2K; [DETOUR] D 2K; [USE EXIT 3] D 2K;

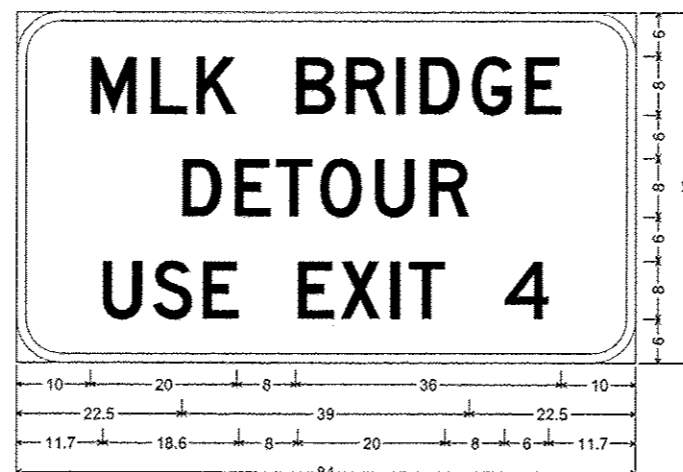

6.0" Radius, 1.3" Border, Black on Orange;
[MLK BRIDGE] D 2K; [DETOUR] D 2K; [USE EXIT 4] D 2K;

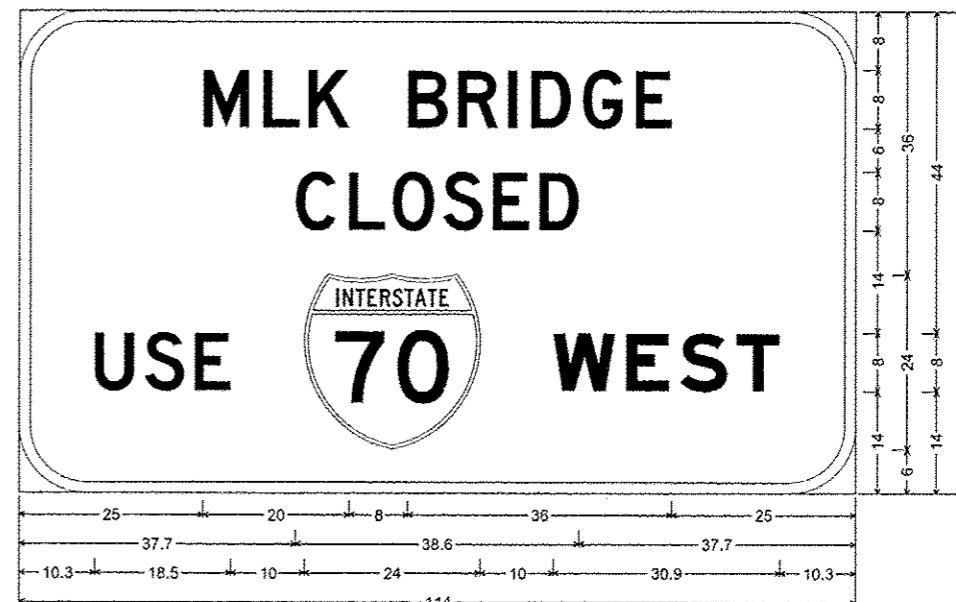

9.0" Radius, 1.5" Border, Black on Orange;
[MLK BRIDGE] D 2K; [CLOSED] D 2K; [USE] D 2K; [WEST] E Mod 2K;

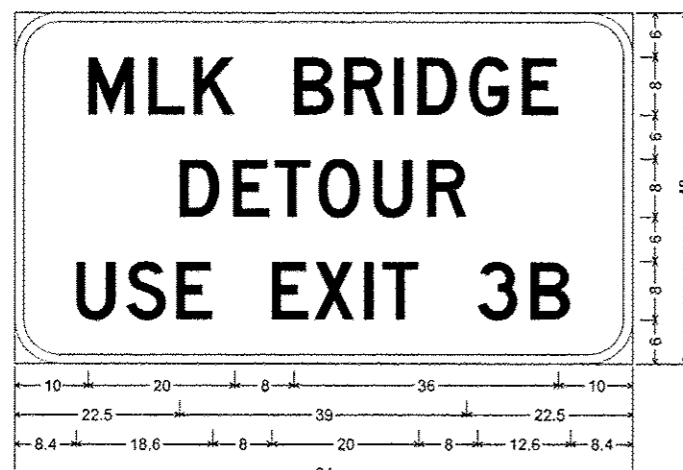

6.0" Radius, 1.3" Border, Black on Orange;
[MLK BRIDGE] D 2K; [DETOUR] D 2K; [USE EXIT 3B] D 2K;

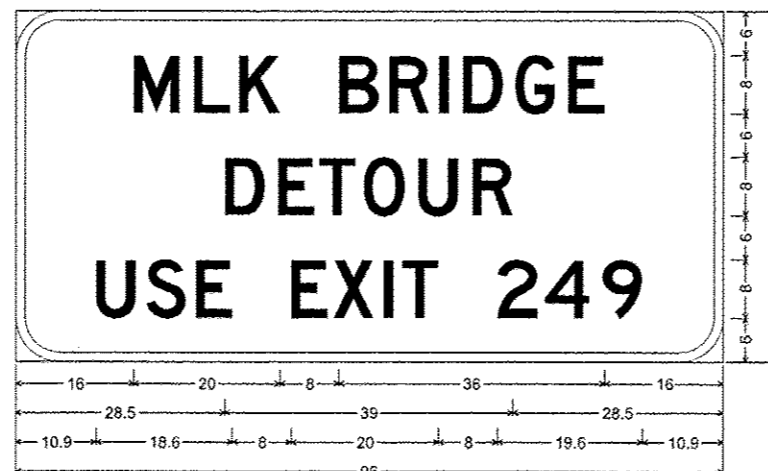

6.0" Radius, 1.3" Border, Black on Orange;
[MLK BRIDGE] D 2K; [DETOUR] D 2K; [USE EXIT 249] D 2K;

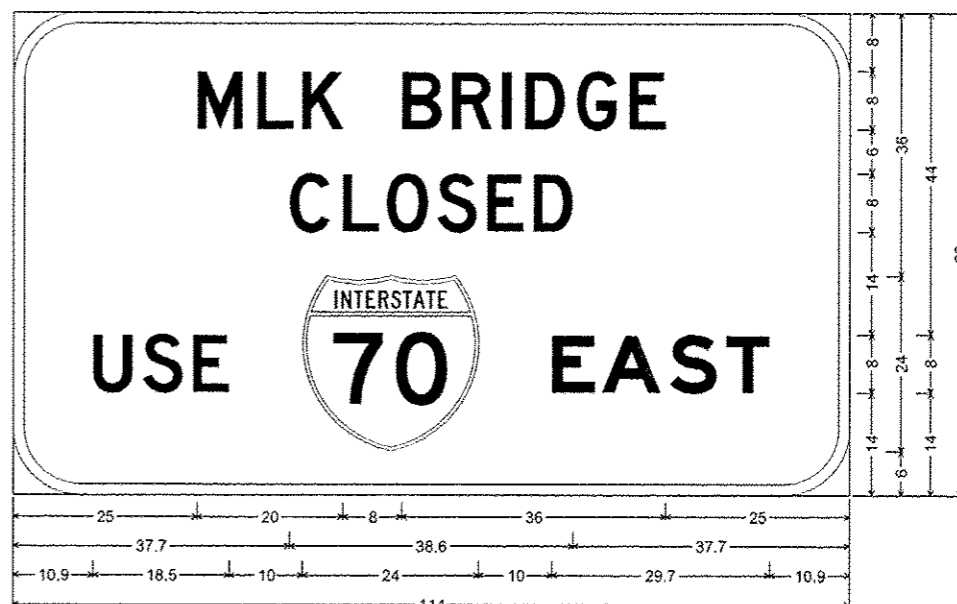

9.0" Radius, 1.5" Border, Black on Orange;
[MLK BRIDGE] D 2K; [CLOSED] D 2K; [USE] D 2K; [EAST] E Mod 2K;

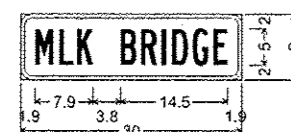

1.5" Radius, 0.5" Border, Black on Orange;
[MLK BRIDGE] B 2K 75% spacing;

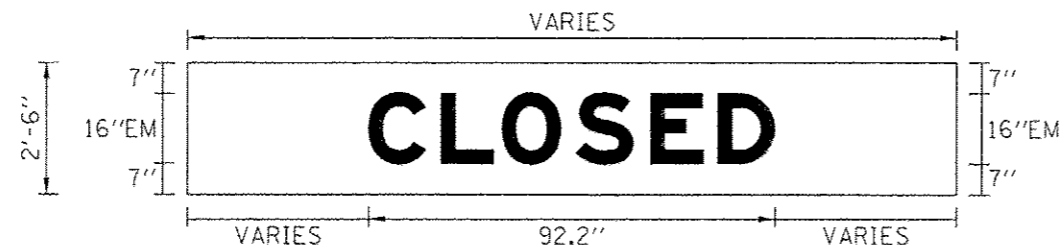

LEGEND: BLACK (NON-REFL)
BACKGROUND: ORANGE (REFL)
DETAIL 'B'

FILE NAME *	USER NAME * #USER*	DESIGNED -	REVISED -	STATE OF ILLINOIS DEPARTMENT OF TRANSPORTATION	TRAFFIC CONTROL PROTECTION PLAN DETOUR SIGNS			F.A.P. RTE.	SECTION	COUNTY	TOTAL SHEETS	SHEET NO.
#FILE#		DRAWN -	REVISED -		SCALE: _____	SHEET NO. 20 OF 20 SHEETS	STA. _____ TO STA. _____	799	1BR, DRS-2	ST. CLAIR	156	10H
		CHECKED -	REVISED -					CONTRACT NO. 76B03				
		DATE -	REVISED -					FED. ROAD DIST. NO. - [ILLINOIS] FED. AID PROJECT				

Bench Mark: BM 107 - Chiseled square on south end of east abutment.
Elev. 439.63 (NAVD 88)

Existing Structure: The Veterans Bridge, S.N. 082-6001, was built in 1951 and renamed the Martin Luther King Bridge in 1968. The 4010'-3 7/8" long structure consists of a three-span cantilevered through truss, seven steel approach spans of various configurations on the Missouri Approach, two simply supported deck truss spans, alternating four-span continuous beam spans and simple beam spans on the Illinois Approach. The structure width varies and currently carries one westbound lane and two eastbound lanes with a concrete median barrier. The deck on the suspended span and the adjacent three panels of each cantilever arm consists of a partially filled steel grid deck. The deck on the remainder of the structure is concrete, acting compositely in some locations. The piers have various concrete wall and steel bent or tower configurations founded on piles or footings on a rock. Abutment A is supported by a spread footing, whereas, Abutment B is pile supported. The bridge underwent a major rehabilitation in 1987 in which the grid deck was replaced and the limits extended from L14-L14' to L17-L17'. Other rehabilitative efforts were made to the floorsystem, joints, and drainage system, in addition to painting the entire structure. Several other rehabilitation contracts have been performed including scour mitigation and changes to the lane configuration.

Traffic: Nightly lane closures and full bridge closure will be utilized to facilitate rehabilitation work.

Salvage: No salvage

LOADING HS20-44 (NEW CONSTRUCTION)

Allow 0#/#sq. ft. for future wearing surface.

DESIGN SPECIFICATIONS

2002 AASHTO Standard Specifications for Highway Bridges, 17th Edition and the AASHTO Manual for Bridge Evaluation, 2nd Edition, with 2011 and 2013 Interims

DESIGN STRESSES (NEW CONSTRUCTION)

FIELD UNITS

f'c = 3,500 psi
f'c = 4,000 psi (Lightweight Concrete)
fy = 60,000 psi (Reinforcement)
fy = 36,000 psi (M270 Grade 36 Structural Steel)
fy = 50,000 psi (M270 Grade 50 Structural Steel)

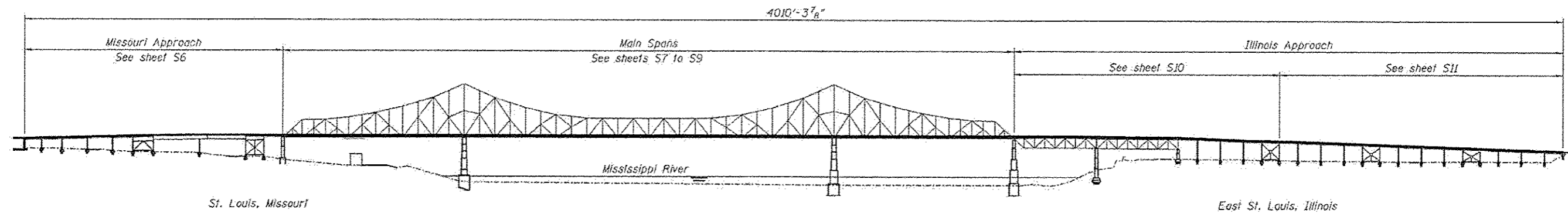

ELEVATION - MARTIN LUTHER KING BRIDGE

(Looking North)

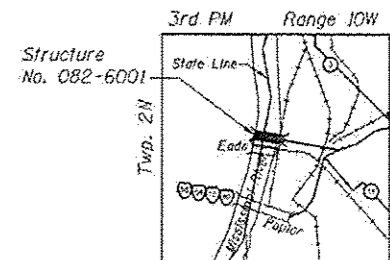
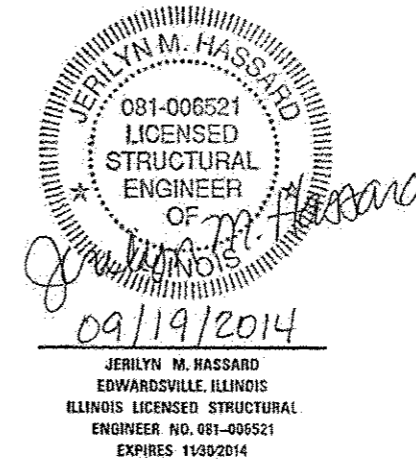

LOCATION MAP

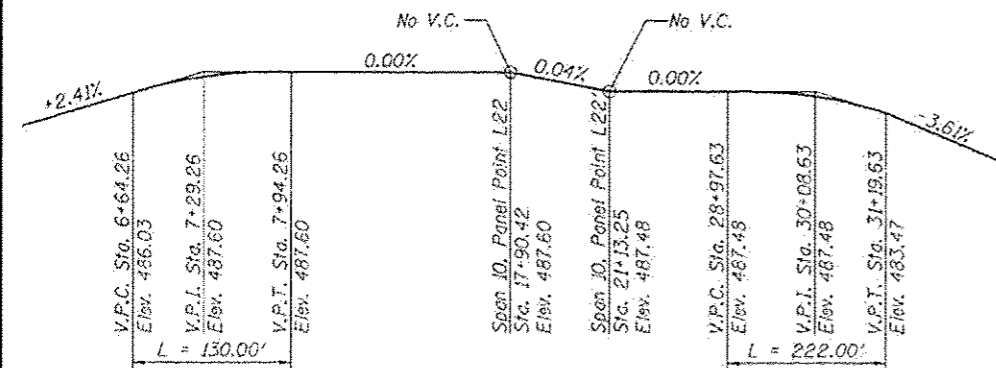

PROFILE GRADE

(@ Bridge)

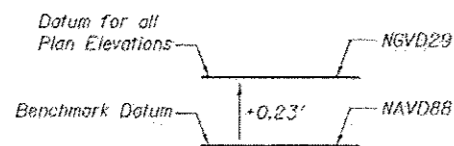

ELEVATION REFERENCES

Note: All elevations refer to U.S.C.&G. Survey - 1929 General Adjustment (NGVD29). Reference is given to the North American Vertical Datum of 1988 (NAVD88) due to the benchmark being referenced to this datum.

DESIGN STRESSES (1951 ORIGINAL)

Design Traffic Lanes: Four - 10' Lanes, No shoulders
Design Specifications: AASHTO 1944
Loading: H20-44
Reinforced Concrete:
Deck Slab: f'c = 1,000 psi, N=10
Substructure: f'c = 1,000 psi, N=10
Structure Steel:
Carbon (A7): fs = 18,000 psi
Silicon: fs = 24,000 psi

DESIGN STRESSES (1987 REHABILITATION)

Design Traffic Lanes: Four - 10' Lanes, No shoulders
Design Specifications: No allowance for future wearing surface
AASHTO 1983 and Manual for Maintenance Inspection for Bridges - 1983, Both with 1984, 1985 and 1986 Interims
Loading: HS20-44
Reinforced Concrete:
Deck Slab: f'c = 3,500 psi, N=9
Lightweight Concrete: f'c = 2,500 psi
Substructure: f'c = 1,400 psi, N=9
Reinforcing Steel: fy = 60,000 psi
fs = 24,000 psi
Structure Steel: fs = 20,000 psi, (M-183)
fs = 27,000 psi, (M-223/Grade 50)
High Strength (H.S.) Bolts: 17,000 psi, (M-164) for Class A Contact Surfaces

GENERAL PLAN
MARTIN LUTHER KING BRIDGE
OVER MISSISSIPPI RIVER (PUBLIC WATER)
F.A.P. ROUTE 799 - SEC. 1BR, DRS-2
ST. CLAIR COUNTY
STATION 20+00.00
STRUCTURE NO. 082-6001

	USER NAME =	DESIGNED - MEL	REVISED	STATE OF ILLINOIS DEPARTMENT OF TRANSPORTATION	GENERAL PLAN S.N. 082-6001 MLK BRIDGE OVER MISSISSIPPI RIVER	F.A.P. RTE.	SECTION	COUNTY	TOTAL SHEETS	SHEET NO.
	PLDT SCALE =	CHECKED - JMH	REVISED			799	1BR, DRS-2	ST. CLAIR	156	19
	PLDT DATE = 09/17/2014	DRAWN - AEC	REVISED			CONTRACT NO. 76803		ILLINOIS FED. AID PROJECT		
		CHECKED - MEL	REVISED			SHEET NO. 51 OF 5139 SHEETS				

INDEX OF SHEETS

S1	General Plan	S69	Main Spans Floorbeam Web Repairs - 5
S2	Index of Sheets and Total Bill of Materials	S70	Main Spans Floorbeam Web Repairs - 6
S3	General Notes, Painting Notes, and Construction Sequence Notes	S71	Main Spans Floorbeam Web Repairs - 7
S4	2013 NBIS Reference Table - 1	S72	Main Spans Floorbeam Web Repairs - 8
S5	2013 NBIS Reference Table - 2	S73	Main Spans Floorbeam Web Repairs - 9
S6	General Plan & Elevation - Missouri Approach Repairs	S74	Main Spans Floorbeam Web Repairs - 10
S7	General Plan & Elevation - Main Span Repairs - 1	S75	Main Spans Floorbeam Web Repairs - 11
S8	General Plan & Elevation - Main Span Repairs - 2	S76	Main Spans Floorbeam Web Repairs - 12
S9	General Plan & Elevation - Main Span Repairs - 3	S77	Main Spans Floorbeam Web Repairs - 13
S10	General Plan & Elevation - Illinois Approach Repairs - 1	S78	Main Spans Floorbeam Web Repairs - 14
S11	General Plan & Elevation - Illinois Approach Repairs - 2	S79	Main Spans Floorbeam Web Repairs - 15
S12	General Plan & Elevation - Lighting Repairs	S80	Main Spans Bottom Lateral Connection Plate Replacements - 1 (Spans 9, 10 and 11)
S13	Existing Lighting Details	S81	Main Spans Bottom Lateral Connection Plate Replacements - 2 (Spans 9, 10 and 11)
S14	Main Spans Grid Deck Details - 1	S82	Illinois Approach End Floorbeam Strengthening - Spans 12 and 13 - 1
S15	Main Spans Grid Deck Details - 2	S83	Illinois Approach End Floorbeam Strengthening - Spans 12 and 13 - 2
S16	Main Spans Grid Deck Details - 3	S84	Illinois Approach Interior Floorbeam Strengthening - Spans 12 and 13
S17	Main Spans Grid Deck Framing Details - 1	S85	Illinois Approach Bottom Lateral Connection Plate Replacement - Span 12 and 13
S18	Main Spans Grid Deck Framing Details - 2	S86	Illinois Approach Beam Strengthening - Span 18, 23, and 28
S19	Main Spans Grid Deck Framing Details - 3	S87	Miscellaneous Repairs
S20	Main Spans Grid Deck Framing Details - 4	S88	Structure Painting
S21	Main Spans Grid Deck Framing Details - 5	S89	Bearing Repairs - 1
S22	Main Spans Grid Deck Framing Details - 6	S90	Bearing Repairs - 2
S23	Main Spans Grid Deck Framing Details - 7	S91	Bearing Repairs - 3
S24	Main Spans Grid Deck Framing Details - 8	S92	Concrete Removal - 1
S25	Main Spans Conduit Hanger Modification Details - 1	S93	Concrete Removal - 2
S26	Main Spans Conduit Hanger Modification Details - 2	S94	Expansion Joint Replacement Details - 1
S27	Main Spans Conduit Hanger Modification Details - 3	S95	Expansion Joint Replacement Details - 2
S28	Concrete Deck Repairs - 1	S96	Expansion Joint Replacement Details - 3
S29	Concrete Deck Repairs - 2	S97	Expansion Joint Replacement Details - 4
S30	Concrete Deck Repairs - 3	S98	Preformed Joint Strip Seal
S31	Main Spans Aluminum Parapet Details - Concrete Deck - 1	S99	Trough Replacement Details - 1
S32	Main Spans Aluminum Parapet Details - Concrete Deck - 2	S100	Trough Replacement Details - 2
S33	Main Spans Aluminum Parapet Details - Grid Deck	S101	Finger Plate Joint Repair - 1
S34	Main Spans Aluminum Parapet Details - Concrete Deck L0-L7	S102	Finger Plate Joint Repair - 2
S35	Main Spans Aluminum Parapet Details - Concrete Deck L7-L14	S103	Finger Plate Joint Repair - 3
S36	Main Spans Aluminum Parapet Details - Concrete Deck L14-L17	S104	Finger Plate Joint Repair - 4
S37	Main Spans Aluminum Parapet Details - Grid Deck L17-L23	S105	Finger Plate Joint Repair - 5
S38	Main Spans Aluminum Parapet Details - Grid Deck L23-L23'	S106	Missouri Approach Bent W Repairs
S39	Main Spans Aluminum Parapet Details - Grid Deck L23'-17'	S107	Missouri Approach Bent 1 Repairs
S40	Main Spans Aluminum Parapet Details - Concrete Deck L17'-L14'	S108	Missouri Approach Bent 2 Repairs
S41	Main Spans Aluminum Parapet Details - Concrete Deck L14'-L7'	S109	Missouri Approach Bent 3 Repairs
S42	Main Spans Aluminum Parapet Details - Concrete Deck L7'-L0'	S110	Missouri Approach Bent 6 Repairs - 1
S43	Missouri Approach Span 6 Cross Beams	S111	Missouri Approach Bent 6 Repairs - 2
S44	Missouri Approach Span 8 Diaphragm Replacement	S112	Missouri Approach Bent 7 Repairs
S45	Main Spans Gusset Plate Strengthening - 1 (L2)	S113	Missouri Approach Bent 13 Repairs
S46	Main Spans Gusset Plate Strengthening - 2 (L4)	S114	Illinois Approach Bent 17 Repairs - 1
S47	Main Spans Gusset Plate Strengthening - 3 (L6)	S115	Illinois Approach Bent 17 Repairs - 2
S48	Main Spans Gusset Plate Strengthening - 4 (L6)	S116	Illinois Approach Bent 18 Repairs
S49	Main Spans Gusset Plate Strengthening - 5 (L8)	S117	Illinois Approach Bent 22 Repairs
S49A	Main Spans Gusset Plate Strengthening - 6 (L10)	S118	Illinois Approach Bent 23 Repairs
S50	Main Spans Gusset Plate Strengthening - 7 (L10)	S119	Illinois Approach Bent 27 Repairs - 1
S50A	Main Spans Gusset Plate Strengthening - 8 (L18)	S120	Illinois Approach Bent 27 Repairs - 2
S51	Main Spans Gusset Plate Strengthening - 9 (L18)	S121	Illinois Approach Bent 28 Repairs - 1
S52	Main Spans Gusset Plate Strengthening - 10 (U2 and M7)	S122	Illinois Approach Bent 28 Repairs - 2
S53	Main Spans Gusset Plate Strengthening - 11 (U4)	S123	Illinois Approach Bent 29 and 30 Repairs
S54	Main Spans Gusset Plate Strengthening - 12 (U8)	S124	Illinois Approach Bent Miscellaneous Details
S54A	Main Spans Gusset Plate Strengthening - 13 (U10)	S125	Substructure and Slope Wall Repair
S55	Main Spans Gusset Plate Strengthening - 14 (U12)	S126	Pier Repair Details
S56	Main Spans Gusset Plate Strengthening - 15 (U18)	S127	Riprap Placement at Piers
S57	Main Spans Stringer Strengthening - PP2-PP6 and PP2'-PP6'	S128	Drainage Repair Details
S62	Main Spans Floorbeam Retrofit Details - 1	S129	Illinois Approach Drainage System - 1
S63	Main Spans Floorbeam Retrofit Details - 2	S130	Illinois Approach Drainage System - 2
S64	Main Spans Floorbeam Retrofit Details - 3	S131	Access Ladder for White Navigation Lights
S65	Main Spans Floorbeam Web Repairs - 1	S132	Proposed Platform for New Red Navigation Light Locations
S66	Main Spans Floorbeam Web Repairs - 2	S133	Dual Monotube Sign Structure
S67	Main Spans Floorbeam Web Repairs - 3	S134	Dual Monotube Sign Structure Details
S68	Main Spans Floorbeam Web Repairs - 4	S135	Bump Out Details 1
		S136	Bump Out Details 2
		S137	Bar Splicer Details
		S138	Illinois ROW Improvements

TOTAL BILL OF MATERIAL

ITEM	UNIT	SUPER	SUB	TOTAL
Tree Removal (Over 15 Units Diameter)	Unit	-	-	300
Stone Dumped Riprap, Class A7	Ton	-	35,085	35,085
Concrete Removal	Cu Yd	109.1	-	109.1
Protective Shield	Sq Yd	617	-	617
Floor Drains	Each	100	-	100
Concrete Superstructure	Cu Yd	110	-	110
Bridge Deck Grooving	Sq Yd	3,058	-	3,058
Furnishing And Erecting Structural Steel	L Sum	1	-	1
Stud Shear Connectors	Each	19,740	-	19,740
Reinforcement Bars, Epoxy Coated	Pound	20,850	-	20,850
Mechanical Splicers	Each	6	-	6
Preformed Joint Strip Seal	Foot	504	-	504
Fabric Reinforced Elastomeric Trough	Foot	214	-	214
Elastomeric Bearing Assembly, Type I	Each	35	-	35
Epoxy Crack Injection	Foot	-	176	176
Chain Link Fence, 8'	Foot	-	-	1,884
Chain Link Gates, 8' X 8' Double	Each	-	-	4
Field Measurements	L Sum	-	-	1
Conduit Support System	L Sum	1	-	1
Remove Existing Lighting System	L Sum	1	-	1
Remove And Reinstall Finger Plate Joint	Each	3	-	3
Access Ladder	Each	3	-	3
Remove And Reinstall Existing Aluminum Parapet	Foot	1,905	-	1,905
Bridge Deck Concrete Sealer	Sq Ft	193,439	-	193,439
Steel Post, Attached To Structures	Each	812	-	812
Overhead Sign Structure - Span, Dual Monotube	Foot	45	-	45
Navigation Lighting System	L Sum	1	-	1
Adjust And Reposition Bearings	Each	14	-	14
Structural Steel Repair	Pound	179,190	-	179,190
Bridge Drainage System Repair	Each	-	10	10
Containment And Disposal Of Lead	L Sum	1	-	1
Paint Cleaning Residues No. 1	L Sum	1	-	1
Cleaning And Painting Steel Bridge No. 1	L Sum	1	-	1
Cleaning Drainage System	L Sum	-	1	1
Structural Repair Of Concrete (Depth Equal To Or Less Than 5 Inches)	Sq Ft	-	95	95
Deck Slab Repair (Partial)	Sq Yd	324	-	324
Drainage System	L Sum	-	1	1
Silicone Joint Sealer, 1.5"	Foot	300	-	300
Jacking Existing Superstructure	L Sum	1	-	1
Polymer Concrete	Cu Ft	-	5	5
Railroad Protective Liability Insurance	L Sum	-	-	1
Slope Wall Repair	Sq Yd	-	9.1	9.1
Temporary Railroad Crossing	Each	-	-	1
Removal Of Existing Filled Grid Deck	L Sum	1	-	1
Steel Grid Deck	Sq Ft	31,026	-	31,026
Concrete Barrier Repair	L Sum	1	-	1



USER NAME =	DESIGNED - JMH	REVISED
PLOT SCALE =	CHECKED - DWP	REVISED
PLOT DATE = 05/09/2014	DRAWN - PRC	REVISED
	CHECKED - JMH	REVISED

**STATE OF ILLINOIS
DEPARTMENT OF TRANSPORTATION**

**INDEX OF SHEETS AND TOTAL BILL OF MATERIAL
S.N. 082-6001 MLK BRIDGE OVER MISSISSIPPI RIVER**

SHEET NO. 52 OF 5138 SHEETS

F.A.P. RTE. 799	SECTION 1BR, DR5-2	COUNTY ST. CLAIR	TOTAL SHEETS 156	SHEET NO. 20
CONTRACT NO. 76B03				
ILLINOIS FED. AID PROJECT				

GENERAL NOTES

Fasteners shall be ASTM A 325 Type 1, mechanically galvanized bolts. Bolts 7/8" dia., open holes 15/16" dia., unless otherwise noted.

The Contractor shall replace all loose, broken, severely corroded or missing rivets with H.S. bolts. Cost included in Structural Steel Repair. The weight of each bolt, not detailed for replacement within the contract plans, shall be in addition to the quantities shown on the plans.

When existing rivets are removed and replaced with bolts, the rivets shall be removed by: 1) drilling, or 2) using a pneumatic chisel to remove the rivet head and a pneumatic punch to drive out the shank. If, in the opinion of the Engineer, rivet shanks cannot be removed by punching without damaging the base metal, the rivet shanks shall be removed by drilling.

Before installing each bolt, all nicks, burrs, corrosion, scale, paint and foreign substance shall be removed from inside the hole and from the surfaces around the hole with a power tool to ensure proper seating of the nut, bolt head and washers. Holes in existing material shall be inspected for fatigue cracking. Any cracking found shall be reported to the Engineer. Necessary repairs will be as directed by the Engineer.

Calculated weight of Furnish and Erect Structural Steel =
 M 270 Grade 36: 29,540 lbs
 M 270 Grade 50: 429,920 lbs

All new Structural Steel shall conform to M270 Grade 36, unless otherwise noted.

No field welding is permitted except as specified in the contract documents.

Reinforcement bars designated (E) shall be epoxy coated.

Cost of removal and re-installation of all steel members necessary to complete the work as detailed on the plans and as specified in the Special Provisions shall be included with Structural Steel Repair or Furnishing and Erecting Structural Steel.

Prior to pouring the new concrete deck, all heavy or loose rust, loose mill scale, and other loose or potentially detrimental foreign material shall be removed from the surfaces in contact with concrete. Tightly adhered paint may remain unless otherwise noted. Removal shall be accomplished by methods that will not damage the steel and the cost will be included in the pay item covering removal of the existing concrete.

As directed by the Engineer, existing construction accessories welded to the top flange of beams and girders shall be removed. The weld areas shall be ground flush and inspected for cracks using magnetic particle testing (MT) or dye penetrant testing (PT) by qualified personnel approved by the Engineer. Any cracks that cannot be removed by grinding 1/4 in. deep shall be identified and reported to the Bureau of Bridges and Structures for further disposition. The cost of removing welded accessories, grinding and inspecting weld areas and grinding cracks will be paid for according to Article 109.04 of the Standard Specifications.

Existing cracked tack welds and miscellaneous steel welded to structural members shall be removed as shown on the plans. The weld areas shall be ground flush and inspected for cracks using magnetic particle testing (MT) or dye penetrant testing (PT) by qualified personnel approved by the Engineer. Any cracks that can not be removed by grinding 1/4 in. deep shall be identified and reported to the Bureau of Bridges and Structures for further disposition. The cost of removing welds, grinding and inspecting weld areas and grinding cracks, as noted on the plans, is included with Structural Steel Repair.

Plan dimensions and details relative to existing plans are subject to nominal construction variations. The Contractor shall field verify existing dimensions and details affecting new construction and make necessary approved adjustments prior to construction or ordering of materials. Such variations shall not be cause for additional compensation for a change in scope of the work, however, the Contractor will be paid for the quantity actually furnished at the unit price bid for the work.

The Contractor shall field verify all proposed R dimensions and spacing of holes prior to ordering steel.

Existing structure plans are available for review in the District office. Contact Tim Padgett at (618) 346-3325.

Structural repairs involving removal and replacement of existing steel components are detailed for replacement in kind. Upon approval by the Engineer, the Contractor may increase angles and/or plate sizes to accommodate current availability restrictions at the expense of the Contractor.

Gaps between the existing steel and the new steel angles and/or cover plates, as well as abandoned holes to be covered by new steel plates and/or angles, shall be sealed with an approved polyurethane sealant. The sealant shall be compatible with the proposed paint system and shall be submitted to the Engineer for approval prior to use. All costs associated with the installation of the sealant shall be included with the cost for Structural Steel Repair.

The Contractor shall perform the work with care, so that any materials which are to remain in place shall not be damaged. If the Contractor damages any materials which are to remain in place, the damaged materials shall be replaced or repaired in a manner satisfactory to the Engineer at the expense of the Contractor.

All material removed from the structure, as specified by this contract, shall become the property of the Contractor and disposed of properly.

The Contractor shall obtain a construction permit from the Illinois Department of Natural Resources (IDNR), Office of Water Resources for any temporary construction activity placed in the water except cofferdams. For this project, the anticipated construction activities within the water are limited to pier repairs, riprap placement, and access to the Illinois riverfront.

PAINTING NOTES

The existing structural steel coating contains lead. The Contractor shall take appropriate precautions to deal with the presence of lead on this project as specified in the special provision for Containment and Disposal of Lead Paint Cleaning Residues.

The Contractor shall submit calculations and details demonstrating the structural integrity of the bridge is maintained under the additional imposed loads of the containment system. See special provisions.

A minimum of 4 air monitors will be required to monitor abrasive blasting operations at this site. See special provision for Containment and Disposal of Lead Paint Cleaning Residues.

Calendar date painting restrictions will be waived for this project. See Special Provisions.

Cleaning and painting of the existing structural steel shall be as specified in the special provision for Cleaning and Painting Existing Steel Structures. All beams, bearings, and other structural steel within 5 ft (measured along the beam) of either side of deck joints shall be cleaned per Near White Blast Cleaning SSPC-SP10. The exterior surfaces, bottom of the bottom flange of the fascia beams, bottom truss chords, splash zone, and noted spot painting shall be cleaned per Commercial Grade Power Tool Cleaning SSPC-SP15. The designated areas cleaned per Near White Blast Cleaning and per Commercial Grade Power Tool Cleaning shall be painted according to the requirements of Paint System 1 OZ/E/U. The Contractor shall match the color of the final finish coat for all interior steel surfaces to the existing paint color on the structure. The Contractor shall match the color of the final finish coat for all exterior surfaces and bottom flange of the fascia beams to the existing paint color on the structure.

Cleaning and painting of existing structural steel in the areas of structural repairs or new structural installations shall be as specified in the special provision for Cleaning and Painting Contact Surface Areas of Existing Steel Structures.

The Organic Zinc Rich Primer/Epoxy/Urethane Paint System shall be used for painting of new structural steel except where otherwise noted. The entire system shall be shop applied, with the exception of the exterior surface and the bottom of the bottom flange of fascia beams, masked off connection surfaces, field installed fasteners and damaged areas shall be touched up in the field. The Contractor shall match the color of the final finish coat for all interior steel surfaces to the existing paint color on the structure. The Contractor shall match the color of the final finish coat for the exterior and bottom flange of the fascia beams to the existing paint color on the structure.

LEGEND

- o Field drill holes
- Shop or field drill holes
- o Existing holes to remain
- I.F. Inside Face
- F.F. Front Face

CONSTRUCTION SEQUENCE

Contractor shall sequence construction in order to complete work in accordance with the required completion date. See Completion Date special provision.

Contractor is required to provide Structural Assessment Reports for proposed work. See special provisions.

The Contractor shall retain the services of an engineering firm, prequalified in the IDOT consultant selection category of Highway Bridges (Complex), for the preparation of the Structural Assessment Report(s). Contractor's pre-approval shall not be applicable for this project. See Special Provision.

Current Ratings on File for Existing Structure
 Inventory: HS 8.8
 Operating: HS 14.8
 Live Load Restrictions: No

Inventory and Operating Ratings and Live Load Restrictions are provided for information only. Inventory and Operating Ratings are based on HS loading and configuration. Live Load Restrictions are based on Illinois legal loads and configurations. The Ratings and Live Load Restrictions are not necessarily representative of capacities to support the Contractor's equipment.

The Contractor is advised that the existing structure contains members that are in a deteriorated condition with reduced load carrying capacity. It is the Contractor's responsibility to account for the condition of the existing structure when developing construction procedures for the complete or partial removal, or replacement of the structure. An Existing Structure Information Package is available upon request as noted in the special provisions.

Grid deck removal and replacement shall be sequenced in order to maintain the structural integrity of the bridge.

COORDINATION

See special provisions for United States Coast Guard (U.S.C.G.) requirements.
U.S.C.G. Contact:
 Mr. Peter J. Sambor, M.P.A.
 U.S.C.G. Bridge Management Specialist
 Coast Guard 8th District
 1222 Spruce Street, Suite 2.107F
 St. Louis, Missouri 63103
 Phone: (314) 269-2380
 U.S.C.G. 24-hour watch center (314) 269-2332

See special provisions for Terminal Railroad Association of St. Louis (T.R.R.A.) requirements.
T.R.R.A. Contact:
 Mr. Asim Raza
 T.R.R.A. of St. Louis
 415 South 18th Street, Suite 200
 St. Louis, Missouri 63103
 Phone: (314) 241-4729



USER NAME	DESIGNED - JMH	REVISED
	CHECKED - DWP	REVISED
PLOT SCALE	DRAWN - PRC	REVISED
PLOT DATE	CHECKED - JMH	REVISED

STATE OF ILLINOIS
 DEPARTMENT OF TRANSPORTATION

GENERAL NOTES
 S.N. 082-6001 MLK BRIDGE OVER MISSISSIPPI RIVER

SHEET NO. 53 OF 5138 SHEETS

F.A.P. RTE.	SECTION	COUNTY	TOTAL SHEETS	SHEET NO.
799	18R, DRS-2	ST. CLAIR	156	21
				CONTRACT NO. 76B03
ILLINOIS FED. AID PROJECT				

Repair Detail No.	09/16/13 NIBS Inspection Deficiency Item No.	Location	Sheet No.
1	99	Abutment A	S99
1	40	Pier 8	S99
1	80	Span 10, Panel Point 22'	S104
1	83	Pier 11	S101
1	96	Pier 13	S102
2	310	Span 6 at Hinge	S92
2	-	Pier 12	S92
2	-	Bent 18	S92
2	-	Bent 23	S92
2	-	Bent 28	S92
3	-	Bent W	S92
3	351	Bent 2	S92
3	-	Bent 3	S92
3	-	Bent 6	S92
3	-	Bent 17	S92
3	-	Bent 22	S92
3	-	Bent 27	S92
4	-	Abutment A to Span 10 L17, Span 10 L17' to Abutment B	S28
5	121	Span 8, Between Beam 5 and Beam 6	S44
6	-	Span 6, Stingers 2 and Stringer 6	S43
7	101	Span W, Beam 7 at Bent W	S90
7	6	Span W, Beam 5 at Bent W	S90
7	110	Span 2, Beam 3 at Bent 2	S90
8	6	Span W, Beam 5 at Bent W	S89
8	7	Span W, Beam 3 at Bent W	S89
8	8	Span X, Beam 6 at Bent W	S89
8	9	Span X, Beam 4 at Bent W	S89
8	10	Span X, Beam 2 at Bent W	S89
8	11	Span 2, Beam 4 at Bent 2	S89
8	115	Span 3, Beam 4 at Bent 2	S89
8	366	Span 18, Beam 3 at Bent 17	S89
8	277	Span 18, Beam 4 at Bent 18	S116
8	34	Span 22, Beam 2 at Bent 22	S89
8	300	Span 28, Beam 4 at Bent 27	S89
9	120	Bent 7, base of North and South Columns	S90
9	280	Bent 18, base of North Column	S90
9	290	Bent 23, base of North Column	S90
9	302	Bent 28, base of North Column	S90
10	67	Span 6, Hinge at Girder 2 and Girder 3	S91
11	102	Bent W, base of South Column	S106
11	350	Bent 1, base of North Column	S107
11	113	Bent 2, base of North Column	S108
11	114	Bent 2, base of South Column	S108
11	384	Bent 2, top of North Column	S108
11	385	Bent 2, top of South Column	S108
11	-	Bent 3 Cap	S109
11	117	Bent 6, 3' above base of South Column	S110
11	-	Bent 6 Cap	S110
11	118	Bent 6, top of North Column	S110
11	13	Bent 6, top of South Column	S110
11	-	Bent 7 Cap	S112
11	-	Bent 13 Cap	S113
11	276	Bent 17, Bent Cap at North end, Beam 5, and South end	S114
11	365	Bent 17, 4' above base of North Column	S114
11	278	Bent 18, Bent Cap at Beam 2	S116
11	343	Bent 18, top of North Column	S116
11	-	Bent 22 Cap	S117
11	380	Bent 22, base of North Column	S117
11	381	Bent 22, base of South Column	S117
11	289	Bent 23, Full Length of Bent Cap	S118
11	35	Bent 23, top of North Column	S118
11	-	Bent 27 Cap	S119
11	382	Bent 27, North Column	S119
11	37	Bent 27, top of North Column	S119
11	97	Bent 27, top of South Column	S119
11	298	Bent 27, top of South Column	S119
11	38	Bent 28, top of North Column	S121
11	301	Bent 28, top and bottom of North Column	S121
11	303	Bent 28, Cap at South Column	S121
11	347	Bent 28, top of South Column	S121
11	304	Bent 29, base of North Column	S123
11	383	Bent 30, base of North Column	S123

Repair Detail No.	09/16/13 NIBS Inspection Deficiency Item No.	Location	Sheet No.
12	-	Span 10, Panel Point 17 to Panel Point 17'	S14
13	122	Span 9 to Span 11	S31
13	123	Span 9 to Span 11	S31
13	22	Span 10, Panel Point 22'N	S33
14	308	Abutment A	S125
14	69	Pier 8	S126
14	82	Pier 10	S126
14	251	Pier 12	S125
14	281	Bent 18 at North Column base	S125
15	228	Pier 11	S126
16	-	Pier 9, Pier 10, Pier 11	S127
17	325	Span 10, U22N Guide Pin	S45
17	326	Span 10, U22S Guide Pin	S45
17	89	Span 10, U22'S Guide Pin	S45
17	90	Span 10, U22'N Guide Pin	S45
17	358	Span 10, L22'N Guide Pin	S45
18	-	Span 9, U4N and U4S	S56
18	-	Span 9, U8N and U8S	S57
18	-	Span 9, U10N and U10S	S58
18	-	Span 9, U12N and U12S	S59
18	-	Span 10, U18N and U18S	S60
18	-	Span 10, U18'N and U18'S	S60
18	-	Span 11, U12'N and U12'S	S59
18	-	Span 11, U10'N and U10'S	S58
18	-	Span 11, U8'N and U8'S	S57
18	-	Span 11, U4'N and U4'S	S56
18	-	Span 9, L2N and L2S	S46
18	-	Span 9, L6N and L6S	S48
18	-	Span 9, L10N and L10S	S51
18	-	Span 10, L18N and L18S	S53
18	-	Span 10, L18'N and L18'S	S53
18	-	Span 11, L10'N and L10'S	S51
18	-	Span 11, L6'N and L6'S	S48
18	-	Span 11, L2'N and L2'S	S46
19	145	Span 9, L8S Inside Gusset Plate	S50
19	146	Span 9, L8N Outside Gusset Plate	S50
19	204	Span 11, L8'S Outside Gusset Plate	S50
19	205	Span 11, L8'S Inside Gusset Plate	S50
19	206	Span 11, L8'N Inside Plate	S50
20	173	Span 10, L25N Inside Plate	S47
21	216	Span 11, L4'N Outside Plate	S47
22	-	Span 9, L4N and L4S	S47
22	-	Span 9, M7N and M7S	S55
22	-	Span 9, U2N and U2S	S55
22	-	Span 11, L4'N and L4'S	S47
22	-	Span 11, M7'N and M7'S	S55
22	-	Span 11, U2'N and U2'S	S55
23	45	Span 9, Sway Brace Connection at M9N	S8
23	354	Span 9, L10S - U10S, 4' above Deck	S8
23	88	Span 10, U17S - M17S, 15' above Deck	S8
23	56	Span 11, L11'S - M11'S, 20' above Deck	S8
23	57	Span 11, Sway Brace Connection at M9'S	S8
23	91	Span 11, L7'S - M7'S, 20' above Deck	S8
24	-	Span 9, Panel Point 2 - Panel Point 6	S61
24	-	Span 11, Panel Point 6' - Panel Point 2'	S61
25	15	Span 9/10, Fibm. 14, South end	S63
25	16	Span 9/10, Fibm. 14, North end	S63
25	-	Span 10, Fibm. 17 North and South ends	S62
25	355	Span 10, Fibm. 20, North and South ends	S62
25	170	Span 10, Fibm. 22, North end	S62
25	49	Span 10, Fibm. 22, South end	S62
25	-	Span 10, Fibm. 25, North and South ends	S62
25	-	Span 10, Fibm. 25', North and South ends	S62
25	23	Span 10, Fibm. 22', North end	S62
25	24	Span 10, Fibm. 22', South end	S62
25	25	Span 10, Fibm. 20', North end	S62
25	26	Span 10, Fibm. 20', South end	S62
25	-	Span 10, Fibm. 17' North and South ends	S62
25	53	Span 10/11, Fibm. 14', North and South ends	S63
25	-	Span 11, Fibm. 8', North and South ends	S63
25	29	Span 11, Fibm. 0', South end	S64
25	30	Span 11, Fibm. 0', North end	S64

Repair Detail No.	09/16/13 NIBS Inspection Deficiency Item No.	Location	Sheet No.
26	78	Span 10, Fibm. 23, North end	S79
27	126	Span 9, Fibm. 1, South end	S65
27	130	Span 9, Fibm. 3, South end	S65
27	148	Span 9, Fibm. 8, near Stringer 7	S66
27	150	Span 9, Fibm. 9, South end	S67
27	153	Span 9, Fibm. 10, South end	S68
27	154	Span 9, Fibm. 11, South end	S69
27	162	Span 10, Fibm. 16, North and South ends	S70
27	168	Span 10, Fibm. 19, North end	S71
27	77	Span 10, Fibm. 21, North and South ends	S78
27	172	Span 10, Fibm. 24, North end	S79
27	180	Span 10, Fibm. 23', 4' from North end	S72
27	184	Span 10, Fibm. 23', South end	S79
27	186	Span 10, Fibm. 21', 4' from North end	S72
27	199	Span 11, Fibm. 11', Btwn. Stringers 1-2 and Stingers 6-7	S73
27	202	Span 11, Fibm. 9', 4' from North end	S75
27	210	Span 11, Fibm. 6', 4' from North end	S76
27	219	Span 11, Fibm. 4', near Stringer 7	S77
28	386	Span 9, Bottom Lateral LOS - LIN at LOS	S80
28	127	Span 9, Bottom Lateral LIN - L2S at LIN	S80
28	129	Span 9, Bottom Lateral L2N - L3S at L2N	S80
28	71	Span 9, Bottom Lateral L3N - L4S at L3N	S80
28	314	Span 9, Bottom Lateral L4N - L5S at L5S	S80
28	86	Span 9, Bottom Lateral L5N - L6S at L6S	S80
28	140	Span 9, Bottom Lateral L6N - L7S at L7S	S80
28	317	Span 9, Bottom Lateral L10S - L11N at L10S	S80
28	320	Span 9, Bottom Lateral L12N - L13S at L13S	S80
28	17	Span 10, Bottom Lateral L15N - L16S at L16S	S81
28	323	Span 10, Bottom Lateral L17N - L18S at L18S	S81
28	165	Span 10, Bottom Lateral L18N - L19S at L19S	S81
28	185	Span 10, Bottom Lateral L22'N - L21'S at L21'S	S81
28	359	Span 10, Bottom Lateral L21'S - L20'N at L21'S	S81
28	188	Span 10, Bottom Lateral L20'N - L19'S at L19'S	S81
28	332	Span 10, Bottom Lateral L18'N - L17'S at L18'N	S81
28	189	Span 10, Bottom Lateral L16'N - L15'S at L16'N	S81
28	55	Span 11, Bottom Lateral L13'S - L12'N at L12'N	S81
28	208	Span 11, Bottom Lateral L7'N - L6'S at L6'S	S81
28	211	Span 11, Bottom Lateral L6'N - L5'S at L6'N	S81
28	94	Span 12, Bottom Lateral U0N - L1S at L1S	S85
28	377	Span 12, Bottom Lateral U0S - L1N at L1N	S85
28	92	Span 12, Bottom Lateral LIN - L2S at LIN	S85
28	95	Span 12, Bottom Lateral LIS - L2N at LIS	S85
28	255	Span 13, Bottom Lateral LOS - LIN at LIN	S85
28	258	Span 13, Bottom Lateral LIN - L2S at LIN	S85
29	-	Span 12 and 13 Floorbeams	S82
30	-	Span 18 Beams 2, 3, 4, 5, 6	S86
30	282	Span 19, Beam 1 at Bent 18	S88
30	-	Span 23 Beams 2, 3, 4, 5, 6	S86
30	-	Span 28 Beams 2, 3, 4, 5, 6	S86
31	363	Span 17, Beam 2 at Bent 17	S90
31	31	Span 17, Beam 6 at Bent 17	S90
31	280	Bent 18, base of North Column	S90
32	306	Span 32, East Abutment Slope Wall	S125
33	-	Spans 9 - 11, replace Navigation Lights and Attachments	S12
34	-	Span 10, install new Navigation Light and Conduit	S12
35	-	Span 10, install access to upper Navigation Lighting	S131

Note:
If repair details encompass multiple sheets,
the first sheet number has been referenced.



USER NAME =	DESIGNED - CDB	REVISED
PLOT SCALE =	CHECKED - ZJB	REVISED
PLOT DATE = 05/02/2014	DRAWN - PRC	REVISED
	CHECKED - JMH	REVISED

STATE OF ILLINOIS
DEPARTMENT OF TRANSPORTATION

2013 NBIS REFERENCE TABLE - 1
S.N. 082-6001 MLK BRIDGE OVER MISSISSIPPI RIVER

SHEET NO. 54 OF 5138 SHEETS

F.A.P. RTE. 799	SECTION 1BR, DRS-2	COUNTY ST. CLAIR	TOTAL SHEETS 156	SHEET NO. 22
ILLINOIS FED. AID PROJECT				

CONTRACT NO. 76B03

Repair Detail No.	09/16/13 NIBS Inspection Deficiency Item No.	Location	Sheet No.
Structural Painting	1	5' Either Side of Deck Joints, Main Spans Splash Zone	S88
Drainage System	368	Span W, South side Deck Drains	S128
Drainage System	369	Bent 1, North Column	S128
Drainage System	309	Span 4, 20' from Bent 3 at Girder 1	S128
Drainage System	-	Span 4, midspan at Girder 4	S128
Drainage System	372	Span 9, South side Deck Drains	S128
Drainage System	-	Span 9, Panel 3 near Stringer 1	S128
Drainage System	-	Span 9, Panel 6 near Stringer 1	S128
Drainage System	144	Span 9, Panel 7 and Panel 8 near Stringer 1	S128
Drainage System	-	Span 9, Panel 8 near Stringer 1 and Stringer 7	S128
Drainage System	305	Bent 31 at North Column	S128
Miscellaneous Steel Repairs	100	Span W, under Stringer 5 at Bent W	S87
Miscellaneous Steel Repairs	-	Bent W, 6' above base of North Column	S87
Miscellaneous Steel Repairs	103	Span X, between Stringer 1 and Stringer 2 at Midspan	S87
Miscellaneous Steel Repairs	104	Span X, between Stringer 3 and Stringer 4 at Midspan	S87
Miscellaneous Steel Repairs	106	Bent 1 at Stringer 6	S87
Miscellaneous Steel Repairs	107	Bent 1 at Stringer 4	S87
Miscellaneous Steel Repairs	-	Bent 1, 4' above base of North Column	S87
Miscellaneous Steel Repairs	-	Bent 1, 4' above base of South Column	S87
Miscellaneous Steel Repairs	108	Span 2, Stringer 7, 5' from Bent 1, 5' from Bent 2, and at Bent 2	S87
Miscellaneous Steel Repairs	109	Span 2, Stringer 1 at Bent 2	S87
Miscellaneous Steel Repairs	-	Bent 3, South Column	S87
Miscellaneous Steel Repairs	66	Bent 3, North Column	S87
Miscellaneous Steel Repairs	-	Bent 4, North Column	S87
Miscellaneous Steel Repairs	-	Bent 6, North Column	S87
Miscellaneous Steel Repairs	-	Bent 6, South Column	S87
Miscellaneous Steel Repairs	119	Bent 7 at Stringer 4	S87
Miscellaneous Steel Repairs	371	Bent 7 at South Column Long. Bracing	S87
Miscellaneous Steel Repairs	311	Span 9, Stringer 7, 6' East of Floorbeam 0	S87
Miscellaneous Steel Repairs	125	Span 9, Floorbeam 1 at Stringer 3	S87
Miscellaneous Steel Repairs	41	Span 9, L4N - U4N, 4' and 20' above Deck	S87
Miscellaneous Steel Repairs	-	Span 9, L4S - U4S, 4' above Deck	S87
Miscellaneous Steel Repairs	-	Span 9, L10S - U10S, 4' above Deck	S87
Miscellaneous Steel Repairs	75	Span 9/10, M14N - M14S, 20' above Deck	S87
Miscellaneous Steel Repairs	48	Span 10, Floorbeam 18 between Stringer 1 and Stringer 2	S87
Miscellaneous Steel Repairs	-	Span 10, L18S - U18S, 4' and 30' above Deck	S87
Miscellaneous Steel Repairs	50	Span 10, L23N - U23N, 4' above Deck	S87
Miscellaneous Steel Repairs	51	Span 10, L23N - U23N, 30' above Deck	S87
Miscellaneous Steel Repairs	177	Span 10, Floorbeam 24' at Stringer 2	S87
Miscellaneous Steel Repairs	21	Span 10, L23'S - U23'S, 30' above Deck	S87

Repair Detail No.	09/16/13 NIBS Inspection Deficiency Item No.	Location	Sheet No.
Miscellaneous Steel Repairs	181	Span 10, Floorbeam 23' at Stringer 3	S87
Miscellaneous Steel Repairs	182	Span 10, Floorbeam 23' at Stringer 4	S87
Miscellaneous Steel Repairs	183	Span 10, Floorbeam 23' at Stringer 4	S87
Miscellaneous Steel Repairs	-	Span 10, L21'N - M21'N, 12' above Deck	S87
Miscellaneous Steel Repairs	187	Span 10, Floorbeam 21' at Stringer 2	S87
Miscellaneous Steel Repairs	-	Span 10, M19'N, outside Gusset Plate	S87
Miscellaneous Steel Repairs	-	Span 10, L18'N - U18'N, 4' and 25' above Deck	S87
Miscellaneous Steel Repairs	190	Span 10, Lower Lateral Connection at L15'N	S87
Miscellaneous Steel Repairs	192	Span 10/11, L14'N, outside Gusset Plate	S87
Miscellaneous Steel Repairs	-	Span 11, L13'S - M13'S, 4' above Deck	S87
Miscellaneous Steel Repairs	54	Span 11, L13'S - M13'S, 40' above Deck	S87
Miscellaneous Steel Repairs	361	Span 11, L11'N inside Gusset Plate	S87
Miscellaneous Steel Repairs	362	Span 11, L11'S inside Gusset Plate	S87
Miscellaneous Steel Repairs	200	Span 11, Stringer 2 at L11'	S87
Miscellaneous Steel Repairs	-	Span 11, L10'N - U10'N, 4' and 30' above Deck	S87
Miscellaneous Steel Repairs	207	Span 11, Floorbeam 8' at L8'N	S87
Miscellaneous Steel Repairs	60	Span 11, Floorbeam 5', North end	S87
Miscellaneous Steel Repairs	-	Span 11, L4'S - U4'S, 4' above Deck	S87
Miscellaneous Steel Repairs	61	Span 11, L4'S - U4'S, 30' above Deck	S87
Miscellaneous Steel Repairs	214	Span 11, L4'N - U4'N, at L4'N	S87
Miscellaneous Steel Repairs	220	Span 11, Floorbeam 4' at Stringer 7	S87
Miscellaneous Steel Repairs	221	Span 11, L4'S - U4'S, at L4'S	S87
Miscellaneous Steel Repairs	62	Span 11, Floorbeam 3' at North end	S87
Miscellaneous Steel Repairs	247	Span 12, U0'S - U1'S at U0'S	S87
Miscellaneous Steel Repairs	339	Span 13, U3N - L4N at 5' from U3N	S87
Miscellaneous Steel Repairs	341	Span 13, Floorbeam 2' at South end	S87
Miscellaneous Steel Repairs	32	Span 21, Stringer 1 at West Splice	S87
Miscellaneous Steel Repairs	33	Bent 22 Tower Bracing	S87
Miscellaneous Steel Repairs	284	Bent 22 at Stringer 2	S87
Miscellaneous Steel Repairs	289	Bent 23 Cap at South end	S87
Miscellaneous Steel Repairs	367	Span 23, Stringer 1 at Bent 23	S87
Miscellaneous Steel Repairs	346	Span 27, Stringer 7 at Midspan	S87
Miscellaneous Steel Repairs	348	Span 30, Stringer 6 at Bent 30	S87
Concrete Median Repair	349	Span X, 12' East of Bent W	S87
Concrete Median Repair	-	Span Y, 12' West of Bent Y	S87
Concrete Median Repair	-	Span 7, at Bent 7	S87
Concrete Median Repair	-	Span 8, 24' West of Pier 8	S87
Concrete Median Repair	-	Span 10, at Panel 22	S87
Decorative Lighting	5	Spans 9 - 13	S12

Note:
If repair details encompass multiple sheets,
the first sheet number has been referenced.



USER NAME =	DESIGNED - CDB	REVISED
	CHECKED - ZJB	REVISED
PLOT SCALE =	DRAWN - PRC	REVISED
PLOT DATE = 03/20/2014	CHECKED - JMH	REVISED

STATE OF ILLINOIS
DEPARTMENT OF TRANSPORTATION

2013 NIBS REFERENCE TABLE - 2
S.N. 082-6001 MLK BRIDGE OVER MISSISSIPPI RIVER

SHEET NO. 55 OF 5138 SHEETS

F.A.P. RTE. 799	SECTION 1BR, ORS-2	COUNTY ST. CLAIR	TOTAL SHEETS 156	SHEET NO. 23
			CONTRACT NO. 76B03	
ILLINOIS FED. AID PROJECT				

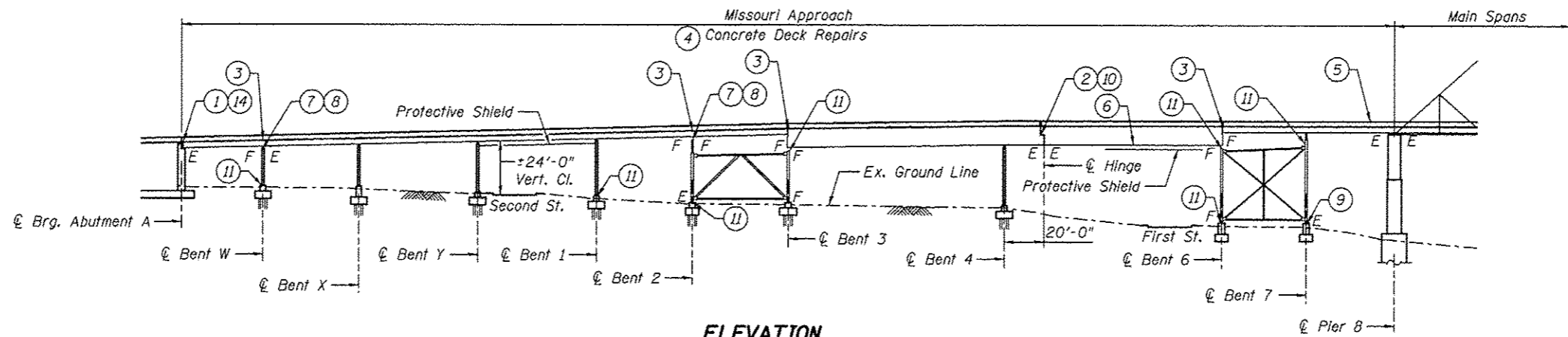

ELEVATION

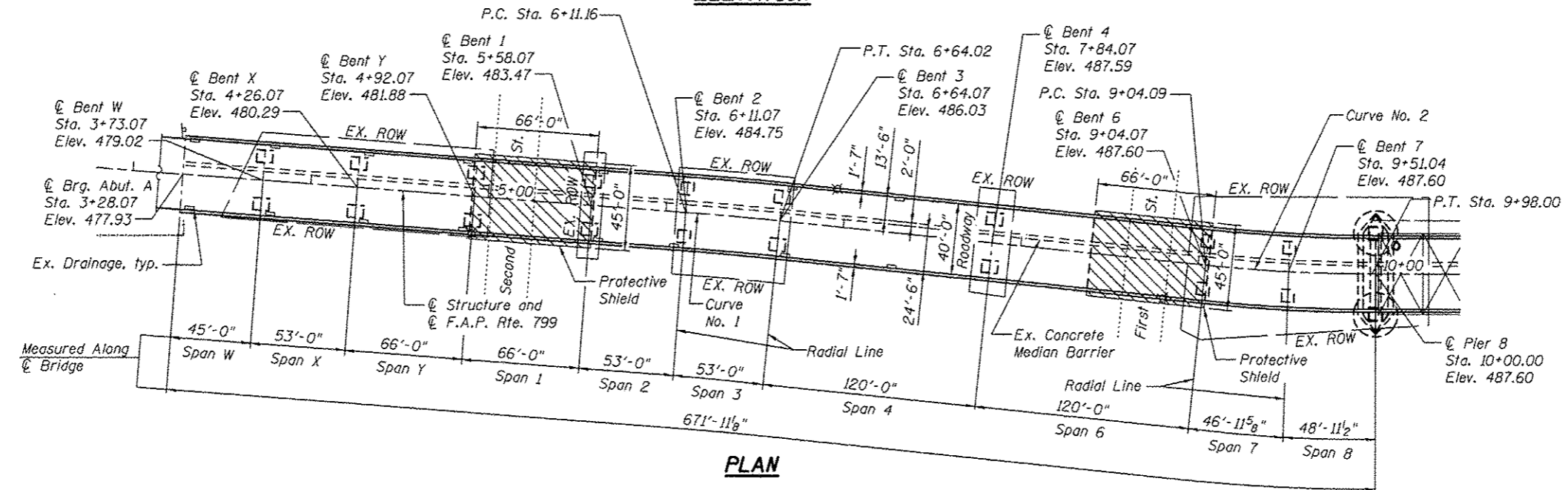

PLAN

CURVE DATA

Curve No. 1
 P.I. Sta. = 6+37.59
 $\Delta = 1^{\circ}35'09''$ (LT)
 $D = 3^{\circ}00'00''$
 $R = 1909.86'$
 $T = 26.43'$
 $L = 52.86'$
 $E = 0.18'$
 P.C. Sta. = 6+11.16
 P.T. Sta. = 6+64.02

Curve No. 2
 P.I. Sta. = 9+51.09
 $\Delta = 5^{\circ}52'10''$ (RT)
 $D = 6^{\circ}15'00''$
 $R = 916.73'$
 $T = 47.00'$
 $L = 93.91'$
 $E = 1.20'$
 P.C. Sta. = 9+04.09
 P.T. Sta. = 9+98.00

MISSOURI APPROACH REPAIR SCHEDULE

ID. NO.	Item	Location	Action
-	Structure Painting	Entire Structure - select locations	Clean and paint repair areas and 5' on each side of deck joints; the existing paint system may contain lead
-	Drainage System	Entire Structure	Repair/Replace drainage system; extend downspouts; clean out drains and drainage system
-	Miscellaneous Steel Repairs	Various members	Remove miscellaneous steel welded to structural members; replace defective fasteners
-	Concrete Median Barrier	Abutment A to Pier 8	Repair median tie rods
1	Joint	Abutment A	Replace finger joint trough
2	Joint	Span 6 at Hinge	Replace neoprene joint with strip seal
3	Joints	Bents W, 2, 3 and 6	Replace preformed joints with strip seals
4	Concrete Deck Repairs	Abutment A to Pier 8	Perform partial depth concrete repairs; seal concrete deck
5	Diaphragm Repair	Span 8 between Beams 5 and 6	Replace diaphragm with excessive offset
6	Stringers	Span 6 Stringers S2 and S6 between Girders G1 and G3 and G5 and G7	Install cross beams to provide additional support
7	Bearings	Bent W, Beams 5 and 7; Bent 2, Beam 3	Repair broken welds
8	Bearings	Bent W, Beams 2, 3, 4, 5, 6 and Bent 2, Beam 4, Spans 2 and 3	Shim gaps between bearing surfaces; repair offset bearing
9	Bearings	Bent 7 N. and S. Column	Clean bearing surfaces at column bases
10	Rocker Bearing	Span 6 Girders 2 and 3 at Hinge	Reset bearings to adjust inclination
11	Steel Columns and Bents	Bent W Cap; Bent W S. Column; Bent 1 N. Column; Bent 2 N. Column, S. Column; Bent 3 Cap; Bent 6 Cap, Bent 6 S. Column, N. Column; Bent 7 Cap	Repair and/or strengthen caps and columns
14	Substructure	Abutment A	Formed Concrete Repair

Notes:
 For 2013 NBIS defect item number and sheet reference, see sheets S4 and S5.
 There is no Bent 5 or Span 5.
 Existing ROW shown is approximate. See general notes on sheet 2 of 156 for further details on ROW limitations and access.



USER NAME :
 PLOT SCALE :
 PLOT DATE : 8/3/2014

DESIGNED - MEL
 CHECKED - CDB
 DRAWN - AEC
 CHECKED - JMH

REVISED
 REVISED
 REVISED
 REVISED

STATE OF ILLINOIS
 DEPARTMENT OF TRANSPORTATION

GENERAL PLAN AND ELEVATION - MISSOURI APPROACH REPAIRS
 S.N. 082-6001 MLK BRIDGE OVER MISSISSIPPI RIVER

SHEET NO. 56 OF 5138 SHEETS

F.A.P. RTE.	SECTION	COUNTY	TOTAL SHEETS	SHEET NO.
799	1BR, DRS-2	ST. CLAIR	156	24

CONTRACT NO. 76B03

ILLINOIS FED. AID PROJECT

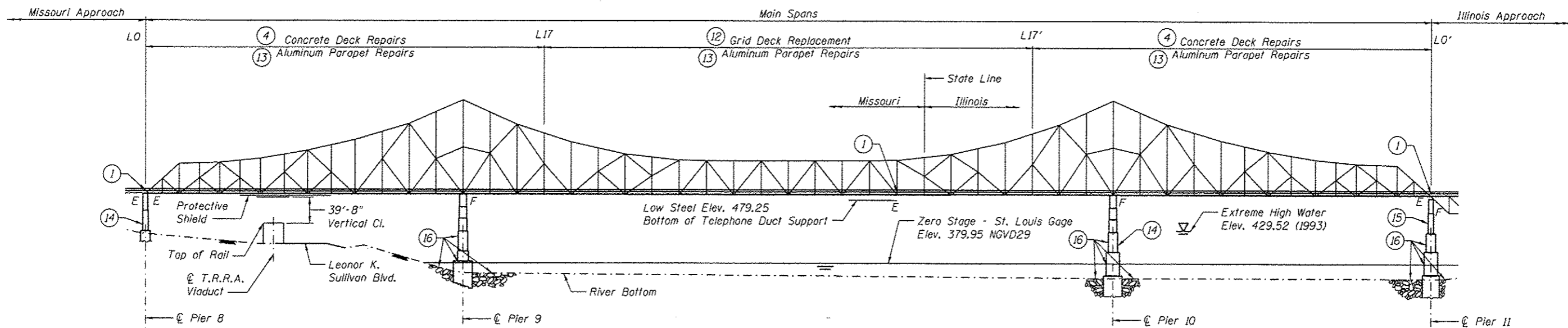

ELEVATION

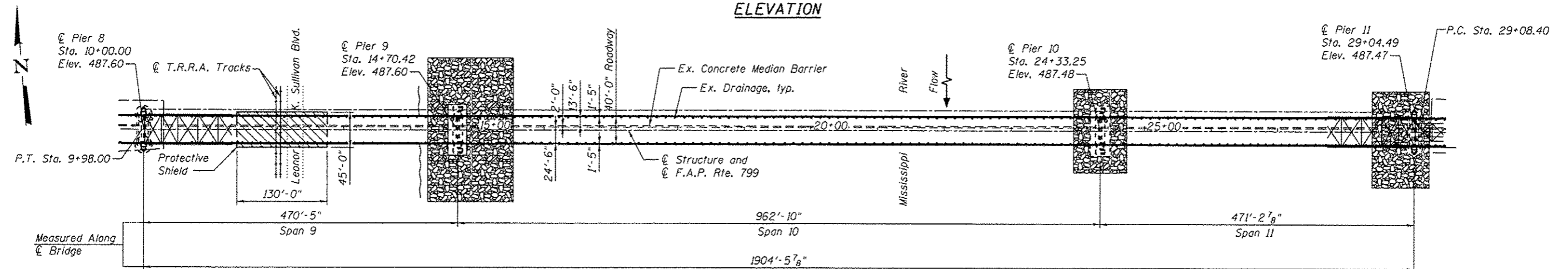

PLAN

MAIN SPAN REPAIR SCHEDULE

ID. NO.	Item	Location	Action
-	Structure Painting	Entire Structure - select locations	Clean and paint splash zone, bottom chord, repair areas, 5' on each side of deck joints, and wind transfer device; the existing paint system may contain lead
-	Drainage System	Entire Structure	Repair/replace drainage system; extend downspouts; clean out drains and drainage system
-	Miscellaneous Steel Repairs	Various members	Remove miscellaneous steel welded to structural members; replace defective fasteners
-	Concrete Median Barrier	Span 9-10 LO to L17, Span 10-11 L17' to LO'	Repair median tie rods
1	Joints	Pier 8, Panel Point 22', Pier 11	Replace finger plate troughs; reset finger plate joint at PP22' and Pier 11
4	Concrete Deck Repairs	Span 9-10 LO to L17, Span 10-11 L17' to LO'	Perform partial depth concrete repairs; seal concrete deck
12	Grid Deck Replacement	Span 10 L17 to L17'	Replace existing grid deck, stringers, and concrete median barrier
13	Aluminum Parapet	Outside limits of grid deck replacement	Install new posts, reuse/replace aluminum skin plate as required; replace fasteners
14	Substructure	Piers 8 and 10	Formed concrete repair
15	Pier	Pier 11	Fill void behind armor plate with polymer concrete
16	Piers	Piers 9, 10 and 11	Seal vertical cracks; place riprap

Notes:
 For 2013 NBIS defect item number and sheet reference, see sheets S4 and S5.
 For guide pin plate repairs see sheet S8.
 For gusset plate strengthening/repairs see sheet S8.
 For floorsystem repairs see sheet S9.
 For navigation/decorative lighting repair/removal see sheet S12.



USER NAME :	DESIGNED - MEL	REVISED
PLOT SCALE :	CHECKED - COB	REVISED
PLOT DATE : 05/02/2014	DRAWN - AEC	REVISED
	CHECKED - JMH	REVISED

STATE OF ILLINOIS
 DEPARTMENT OF TRANSPORTATION

GENERAL PLAN AND ELEVATION - MAIN SPAN REPAIRS 1
 S.N. 082-6001 MLK BRIDGE OVER MISSISSIPPI RIVER

F.A.P. RTE. 799	SECTION 1BR, DRS-2	COUNTY ST. CLAIR	TOTAL SHEETS 156	SHEET NO. 25
CONTRACT NO. 76B03				
ILLINOIS FED. AID PROJECT				

Upper Gusset Plate Numbering

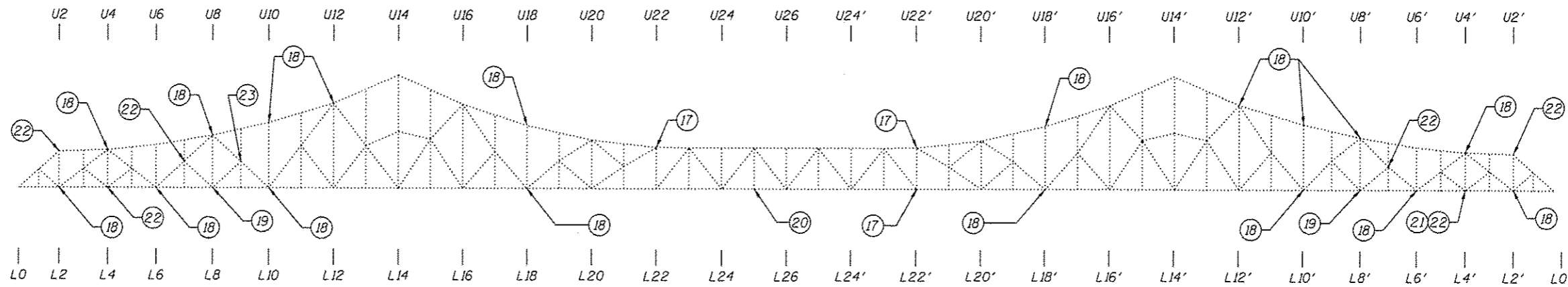

NORTH TRUSS
(Looking North)

Upper Gusset Plate Numbering

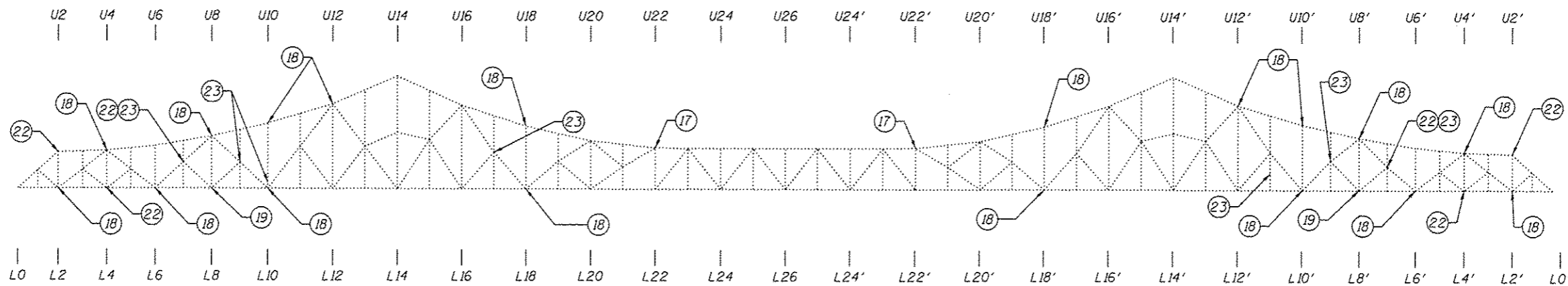

SOUTH TRUSS
(Looking North)

MAIN SPAN TRUSS REPAIR SCHEDULE

ID. NO.	Item	Location	Action
17	Guide Pin Plates	Top and Bottom Chords U22N-U23N, U22S-U23S, U22'N-U23'N, U22'S-U23'S, L22'N-L21'N	Attach new guide plates
18	Gusset Plate Strengthening (North and South Truss)	Upper Chord Gusset Plates U4, U8, U10, U12, U18, U18', U12', U10', U8', U4'	Strengthen
		Lower Chord Gusset Plates L2, L6, L10, L18, L18', L10', L6', L2'	
19	Gusset Plate Repairs	L8S, L8'S, L8N, L8'N	Repair
20	Gusset Plate Repair	L25N	Repair delaminated IS gusset plate
21	Gusset Plate Repair	L4'N	Straighten warped OS gusset plate
22	Gusset Plate Stiffening	L4, M7, U2, L4', M7', U2' (North and South Truss)	Stiffen slender edges of gusset plates
23	Tack Welds	Sway Brace at L7S-M7S; Sway Brace at L9S-M9S; Sway Brace at L9N-M9N; L10S-U10S 4' above deck; M17S-U17S 15' above deck; L11'S-M11'S 20' above deck; Sway Brace at L9'S-M9'S; L7'S-M7'S 20' above deck	Remove partially cracked tack welds

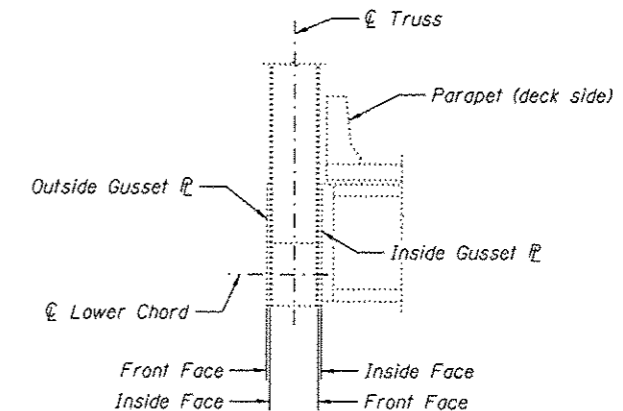

TRUSS CROSS SECTION

Notes:
For 2013 NBIS defect item number and sheet reference, see sheets S4 and S5.
Tack welds shall be removed in accordance with the general notes, see sheet S3. The cost of removing tack welds is included with Structural Steel Repair.



USER NAME	DESIGNED - MEL	REVISED
PLOT SCALE	CHECKED - COB	REVISED
PLOT DATE	DRAWN - AEC	REVISED
	CHECKED - JMH	REVISED

STATE OF ILLINOIS
DEPARTMENT OF TRANSPORTATION

GENERAL PLAN AND ELEVATION - MAIN SPAN REPAIRS 2
S.N. 082-6001 MLK BRIDGE OVER MISSISSIPPI RIVER

SHEET NO. 58 OF 5138 SHEETS

F.A.P. RTE.	SECTION	COUNTY	TOTAL SHEETS	SHEET NO.
799	1BR, DRS-2	ST. CLAIR	156	26
CONTRACT NO. 76B03				
ILLINOIS FED. AID PROJECT				

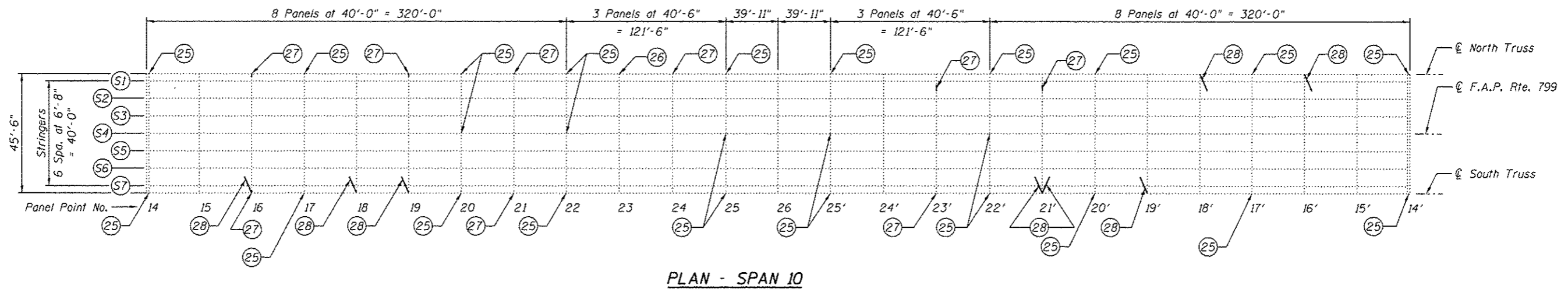
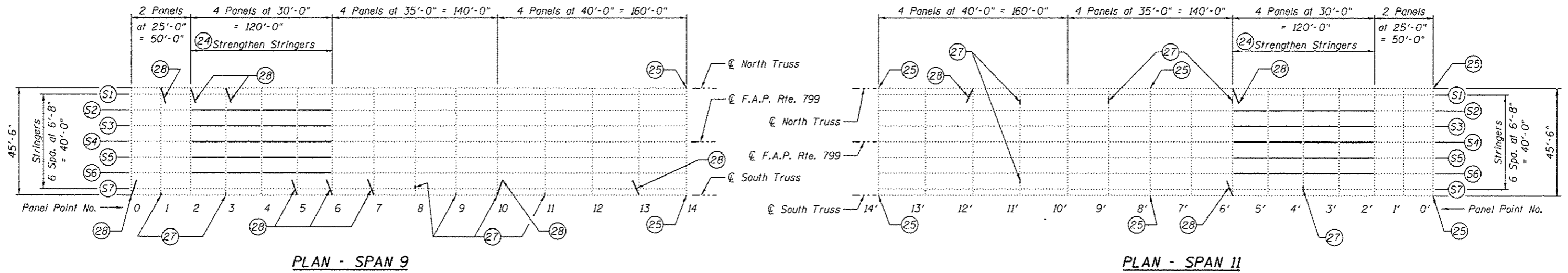

MAIN SPAN FLOORSYSTEM REPAIR SCHEDULE			
ID. NO.	Item	Location	Action
24	Stringers	PP2-PP6, PP6'-PP2'	Strengthen
25	Floorbeams	FB 14, FB 17, FB 20, FB 22, FB 25, FB 25', FB 22', FB 20', FB 17', FB 14', FB 8', FB 0'	Strengthen and/or retrofit for cracking
26	Floorbeam	FB 23, North End	Remove delamination on bottom flange
27	Floorbeams	FB 1S, FB 3S, FB 8 at S7, FB 9S, FB 10S, FB 11S, FB 16N and S, FB 19N, FB 21N and S, FB 24N, FB 23'N 4' from end, FB 23'S, FB 21'N 4' from end, FB 11' between S1-S2 and S6-S7, FB 9'N 4' from end, FB 6'N 4' from end, FB 4' at S7	Repair floorbeam webs
28	Bottom Lateral Connection Plates	L0S-L1N at L0S, L1N-L2S at L1N, L2N-L3S at L2N, L3N-L4S at L3N, L4N-L5S at L5S, L5N-L6S at L6S, L6N-L7S at L7S, L10S-L11N at L10S, L12N-L13S at L13S, L15N-L16S at L16S, L17N-L18S at L18S, L18N-L19S at L19S, L22'N-L21'S at L21'S, L21'S-L20'N at L21'S, L20'N-L19'S at L19'S, L18'N-L17'S at L18'N, L16'N-L15'S at L16'N, L13'S-L12'N at L12'N, L7'N-L6'S at L6'S, L6'N-L5'S at L6'N	Replace bottom lateral connection plates or end stay plates

Note:
For 2013 NBIS defect item number and sheet reference,
see sheets S4 and S5.



USER NAME	DESIGNED - MEL	REVISED
	CHECKED - CDB	REVISED
PLOT SCALE	DRAWN - AEC	REVISED
PLOT DATE - 05/02/2014	CHECKED - JMH	REVISED

STATE OF ILLINOIS
DEPARTMENT OF TRANSPORTATION

GENERAL PLAN AND ELEVATION - MAIN SPAN REPAIRS 3
S.N. 082-6001 MLK BRIDGE OVER MISSISSIPPI RIVER

SHEET NO. 59 OF 5138 SHEETS

F.A.P. RTE. 799	SECTION 1BR, DRS-2	COUNTY ST. CLAIR	TOTAL SHEETS 156	SHEET NO. 27
ILLINOIS FED. AID PROJECT			CONTRACT NO. 76B03	

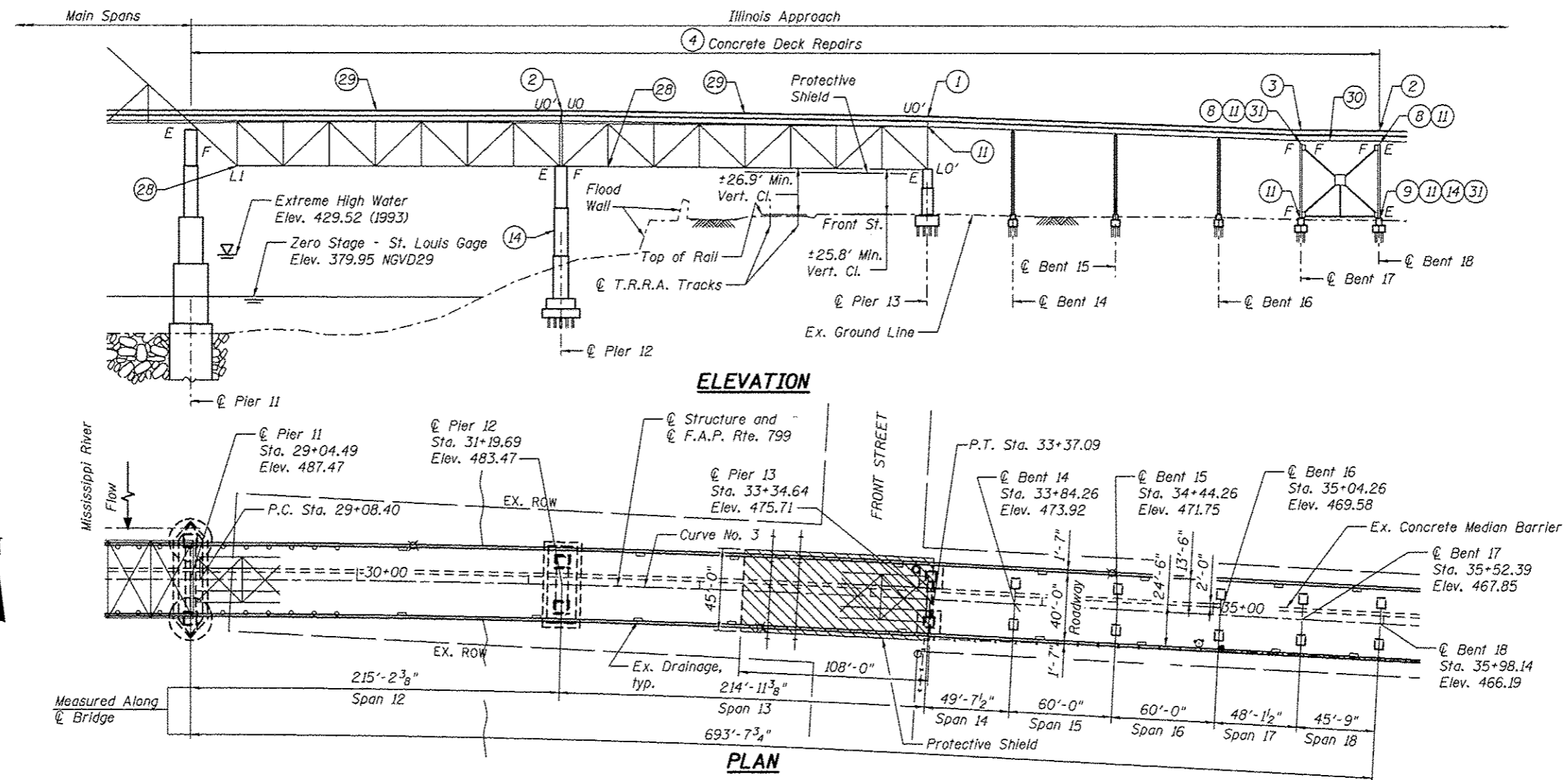

ILLINOIS APPROACH REPAIR SCHEDULE - 1

ID. NO.	Item	Location	Action
-	Structure Painting	Entire Structure - select locations	Clean and paint repair areas and 5' on each side of deck joints; the existing paint system may contain lead
-	Drainage System	Entire Structure	Replace/Repair drainage system; extend downspouts; clean out drains and drainage system
-	Miscellaneous Steel Repairs	Various members	Remove miscellaneous steel welded to structural members; replace defective fasteners
-	Concrete Median Barrier	Pier 11 to Bent 18	Repair median tie rods
1	Joint	Pier 13	Replace finger joint trough
2	Joints	Pier 12 and Bent 18	Replace neoprene joints with strip seals
3	Joint	Bent 17	Replace preformed joint with strip seal
4	Concrete Deck Repairs	Pier 11 to Bent 18	Perform partial depth concrete repairs; seal concrete deck
8	Bearing	Bent 17 at Beam 3; Bent 18 at Beam 4	Shim gap between bearing plates; replace tap bolts
9	Bearing	Bent 18 N. Column Base	Clean bearing surfaces at column bases
11	Steel Columns and Bents	Bent Cap 13; Bent Cap 17; Bent 17 N. Column; Bent Cap 18; Bent 18 N. Column	Repair and/or strengthen caps and columns
14	Substructure	Pier 12 and Bent 18	Formed concrete repair
28	Bottom Lateral Connection Plates	Span 12 UOS-LIN at LIN; UON-LIS at LIS; LIN-L2S at LIN; LIS-L2N at LIS Span 13 LOS-LIN at LIN; LIN-L2S at LIN	Replace bottom lateral connection plates
29	Floorbeams	Spans 12 and 13	Strengthen floorbeams (All 18)
30	Beams	Span 18	Strengthen beams 2, 3, 4, 5 and 6
31	Bearings	Span 17 at Bent 17, Beams 2 and 6; Bent 18, North Column at Base	Remove pack rust

CURVE DATA

Curve No. 3
P.I. Sta. = 31+22.79
 $\Delta = 3^{\circ}00'03''$ (RT)
 $D = 0^{\circ}42'00''$
 $R = 8185.11'$
 $T = 214.39'$
 $L = 428.69'$
 $E = 2.81'$
P.C. Sta. = 29+08.40
P.T. Sta. = 33+37.09

Note:
For 2013 NBIS defect item number and sheet reference, see sheets S4 and S5.



USER NAME =	DESIGNED - MEL	REVISED
	CHECKED - CDB	REVISED
PLOT SCALE =	DRAWN - AEC	REVISED
PLOT DATE = 03/28/2014	CHECKED - JMH	REVISED

STATE OF ILLINOIS
DEPARTMENT OF TRANSPORTATION

GENERAL PLAN AND ELEVATION - ILLINOIS APPROACH REPAIRS 1
S.N. 082-6001 MLK BRIDGE OVER MISSISSIPPI RIVER

F.A.P. RTE. 799	SECTION 1BR, DRS-2	COUNTY ST. CLAIR	TOTAL SHEETS 156	SHEET NO. 28
CONTRACT NO. 76B03			ILLINOIS FED. AID PROJECT	

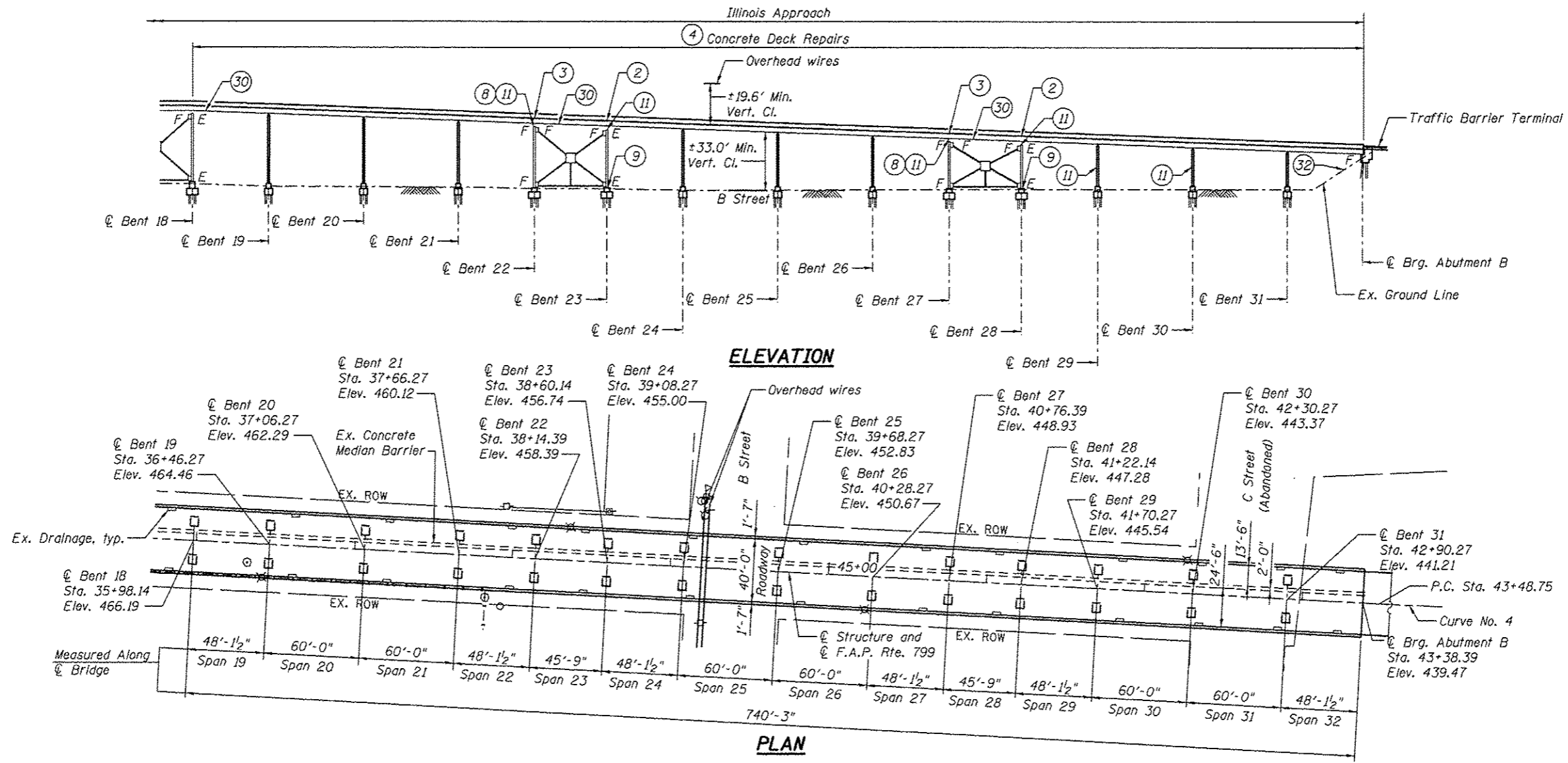

ILLINOIS APPROACH REPAIR SCHEDULE - 2			
ID. NO.	Item	Location	Action
-	Structure Painting	Entire Structure - select locations	Clean and paint repair areas and 5' on each side of deck joints; the existing paint system may contain lead
-	Drainage System	Entire Structure	Replace/Repair drainage system; extend downspouts; clean out drains and drainage system
-	Miscellaneous Steel Repairs	Various members	Remove miscellaneous steel welded to structural members; replace defective fasteners
-	Concrete Median Barrier	Bent 18 to Abutment B	Repair median tie rods
2	Joints	Bent 23 and Bent 28	Replace neoprene joints with strip seals
3	Joints	Bent 22 and Bent 27	Replace preformed joints with strip seals
4	Concrete Deck Repairs	Bent 18 to Abutment B	Perform partial depth concrete repairs; seal concrete deck
8	Bearings	Bent 22 at Beam 2; Bent 27 at Beam 4	Shim gap between bearing plates
9	Bearings	Bent 23, North Column; Bent 28, North Column	Clean bearing surfaces at column bases
11	Steel Columns and Bents	Bent Cap 22; Bent 22 N. and S. Columns; Bent Cap 23, Bent 23 N. Column; Bent Cap 27; Bent 27 N. Column, Bent Cap 28; Bent 28 N. and S. Columns; Bent 29 N. Column; Bent 30 N. Column	Repair and or strengthen caps and columns
30	Beams	Span 19, Beam 1; Span 23 and Span 28 Beams 2, 3, 4, 5 and 6	Paint deteriorated beam end; Strengthen
32	Slopedwall	Abutment B	Repair slopedwall

CURVE DATA
 Curve No. 4
 P.I. Sta. = 44+48.46
 $\Delta = 5^{\circ}58'37''$ (LT)
 $D = 3^{\circ}00'00''$
 $R = 1909.86'$
 $T = 99.71'$
 $L = 199.23'$
 $E = 2.60'$
 P.C. Sta. = 43+48.75
 P.T. Sta. = 45+47.98

Note:
 For 2013 NBIS defect item number and sheet reference, see sheets S4 and S5.



USER NAME =	DESIGNED - MEL	REVISED
	CHECKED - CDB	REVISED
PLOT SCALE =	DRAWN - AEC	REVISED
PLOT DATE = 8/3/2014	CHECKED - JMH	REVISED

STATE OF ILLINOIS
 DEPARTMENT OF TRANSPORTATION

GENERAL PLAN AND ELEVATION - ILLINOIS APPROACH REPAIRS 2
 S.N. 082-6001 MLK BRIDGE OVER MISSISSIPPI RIVER

F.A.P. RTE. 799	SECTION 1BR, DRS-2	COUNTY ST. CLAIR	TOTAL SHEETS 156	SHEET NO. 29
CONTRACT NO. 76B03				

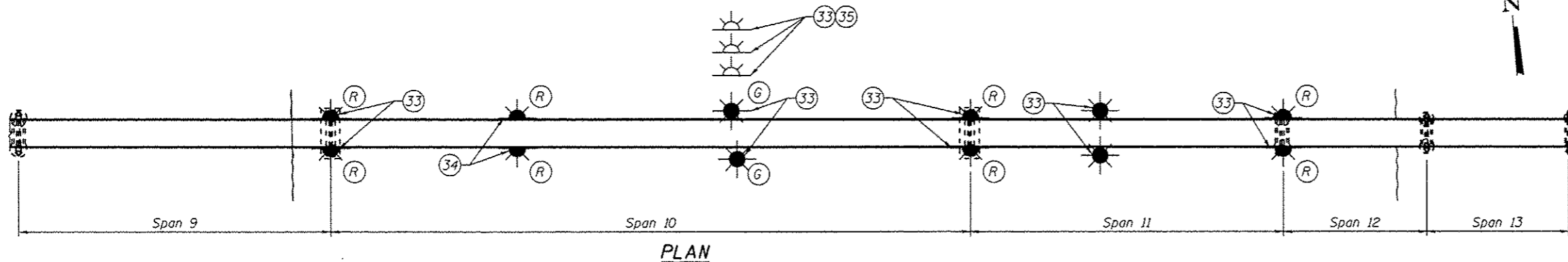
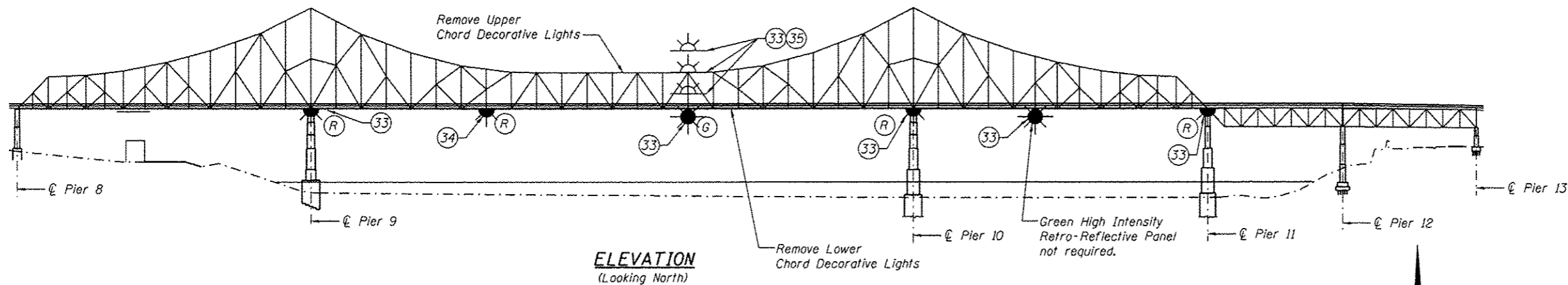

DECORATIVE AND NAVIGATION LIGHTING REPAIR SCHEDULE			
ID. NO.	Item	Location	Action
-	Decorative Lighting	Spans 9-11	Remove decorative lighting wire, junction boxes and mounting bracket - See sheet S13
33	Navigation Lighting	Spans 9-11	Replace navigation light assembly with LED light assembly - See sheet S13
34	Navigation Lighting	Span 10	Install proposed LED assembly, mounting bracket, conduit, retro-reflective panel and access platform with ladder
35	Navigation Lighting	Span 10	Install access ladder to upper white lights

CONSTRUCTION SEQUENCE:

1. Remove the upper chord and lower chord decorative lights including drop boxes, equipment enclosures, mounts and mounting hardware, flexible cables, wires and conduits. The conduits should be checked to ensure that they do not carry wires for other bridge lights.
2. Remove 10 existing red or green navigation light assemblies.
3. Properly mount all proposed LED navigation light assemblies to existing mounts, modifying existing mounts only as needed to keep at same mounting height.
4. Any supporting equipment that is no longer needed shall be removed.
5. Replace white navigation light assemblies.
 - a. Remove 3 existing white navigation light assemblies and replace with LED navigation light assemblies.
 - b. Verify location of existing white navigation light mounting brackets and adjust as necessary to meet current requirements. Replace conduit and mounting brackets as required, to meet vertical location requirements.
 1. The first light to be mounted between 10-15ft above the green light.
 2. The white lights to be mounted 7-15ft apart.
6. Add new hardware at PP 21 for the mounting of the proposed red LED navigation light assembly. Install 4' x 4' red retro reflective panel which conforms to current USCG requirements to proposed North and South navigation light access platforms.

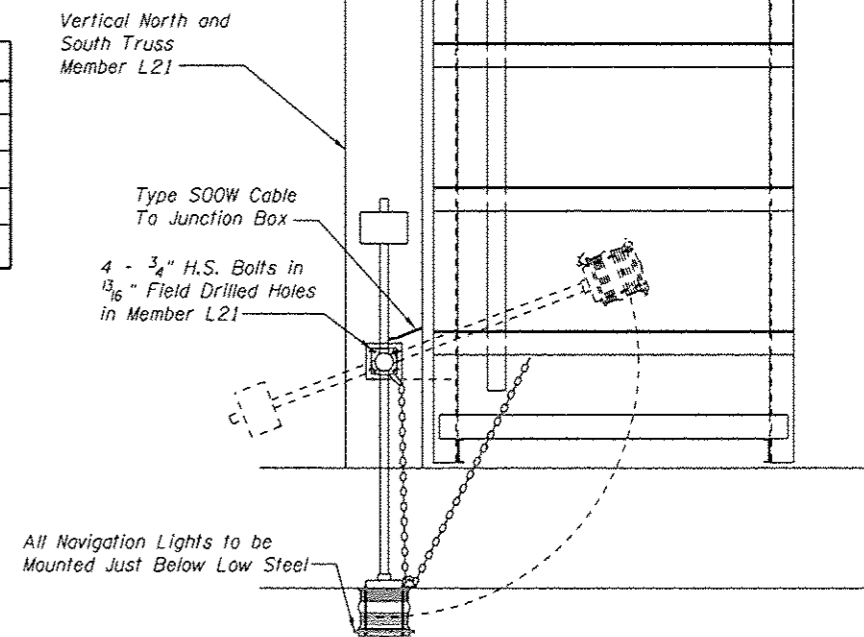
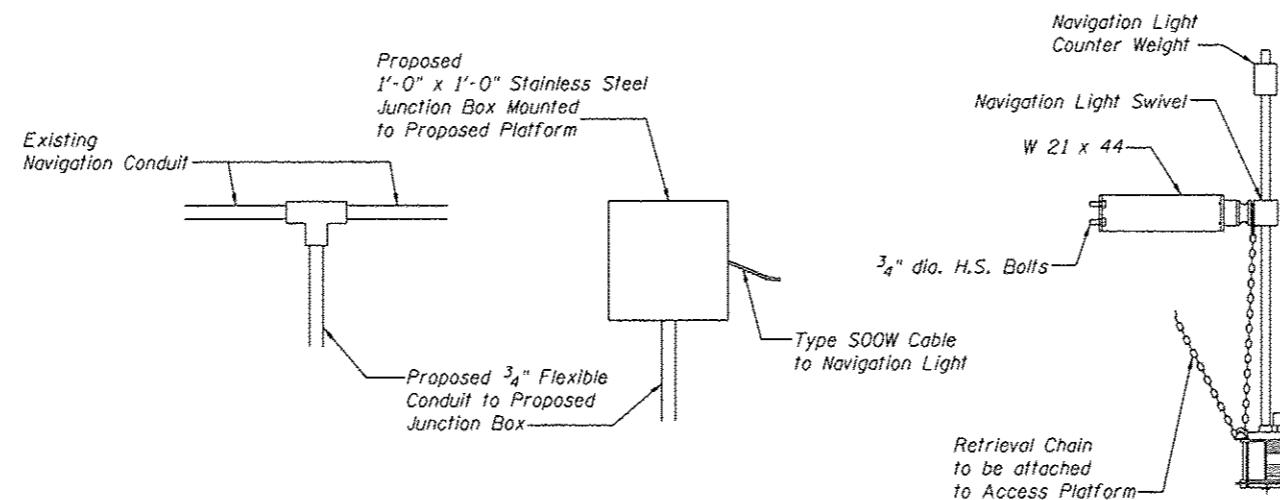

BILL OF MATERIAL

Item	Unit	Total
Navigation Lighting System	L. Sum	1
Remove Existing Lighting System	L. Sum	1

Notes:
See Navigation Lighting System and Remove Existing Lighting System Special Provisions for additional information related to this work.
For access ladder details, see sheet S131.
For proposed platform details, see sheet S132.



Replace Each Span Navigation Light Assembly with LED Navigation Light Assemblies at Existing Mounting Brackets

EXISTING NAVIGATION LIGHT
(TYPICAL)



Replace Each White Navigation Light Assembly with LED Navigation Light Assemblies (see Construction Sequence on Sheet S12)

EXISTING WHITE NAVIGATION LIGHT
(TYPICAL)



Remove Upper Chord Decorative Lights, Supports, and Cable Back to Nearest Junction Box

EXISTING UPPER CHORD
DECORATIVE LIGHTING
(TYPICAL)

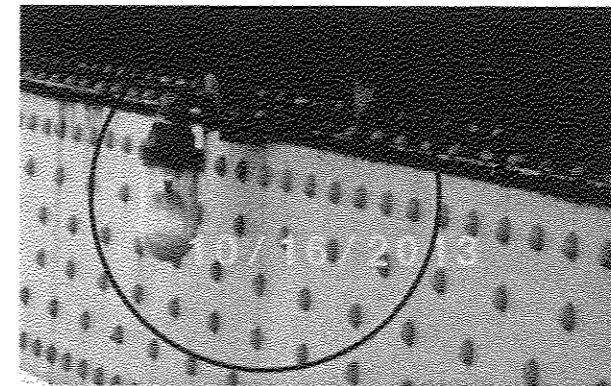

Remove Lower Chord Decorative Lights, Supports, and Cable Back to Nearest Junction Box

EXISTING LOWER CHORD
DECORATIVE LIGHTING
(TYPICAL)



USER NAME	DESIGNED - AMM	REVISED
	CHECKED - JGS	REVISED
PLOT SCALE	DRAWN - AMM	REVISED
PLOT DATE 12/23/2014	CHECKED - JGS	REVISED

STATE OF ILLINOIS
DEPARTMENT OF TRANSPORTATION

EXISTING LIGHTING DETAILS
S.N. 082-6001 MLK BRIDGE OVER MISSISSIPPI RIVER

SHEET NO. 513 OF 5130 SHEETS

F.A.P. RTE.	SECTION	COUNTY	TOTAL SHEETS	SHEET NO.
799	1BR, DRS-2	ST. CLAIR	156	31
CONTRACT NO. 76B03				
ILLINOIS FED. AID PROJECT				

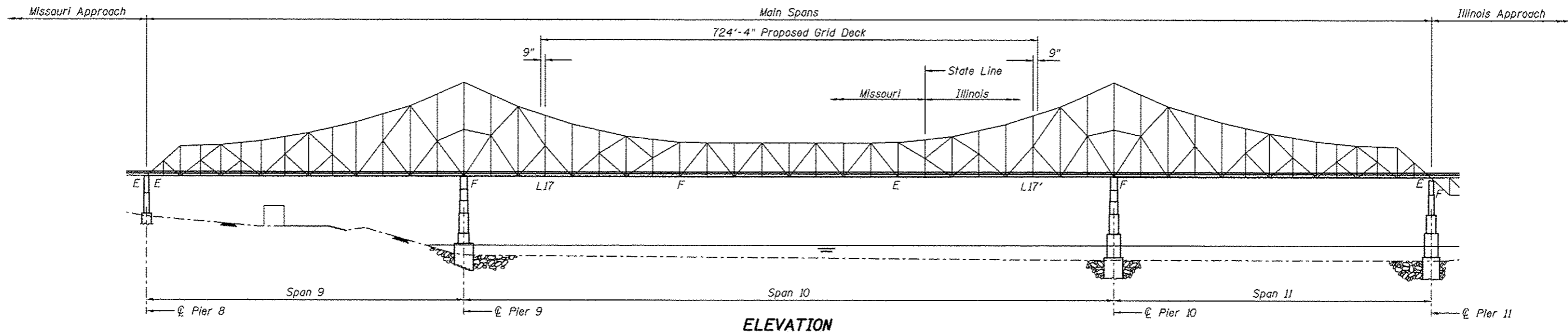

ELEVATION

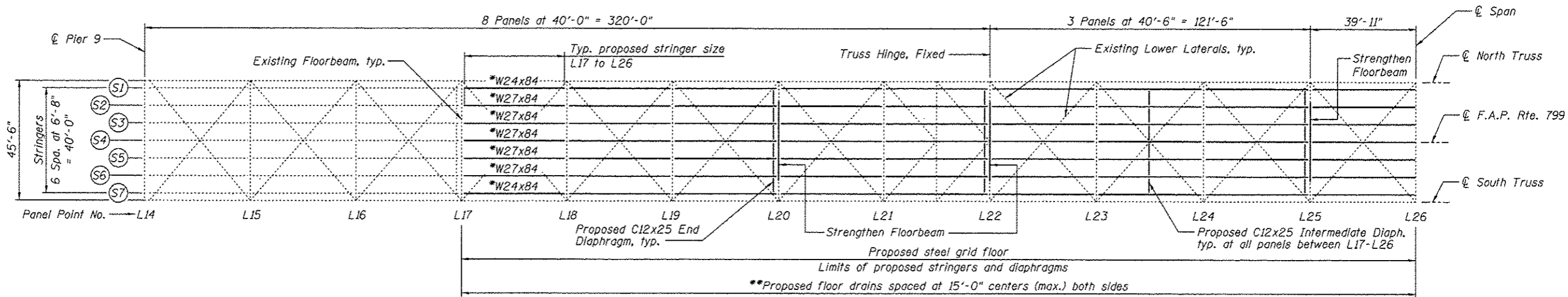

PART PLAN - SPAN 10

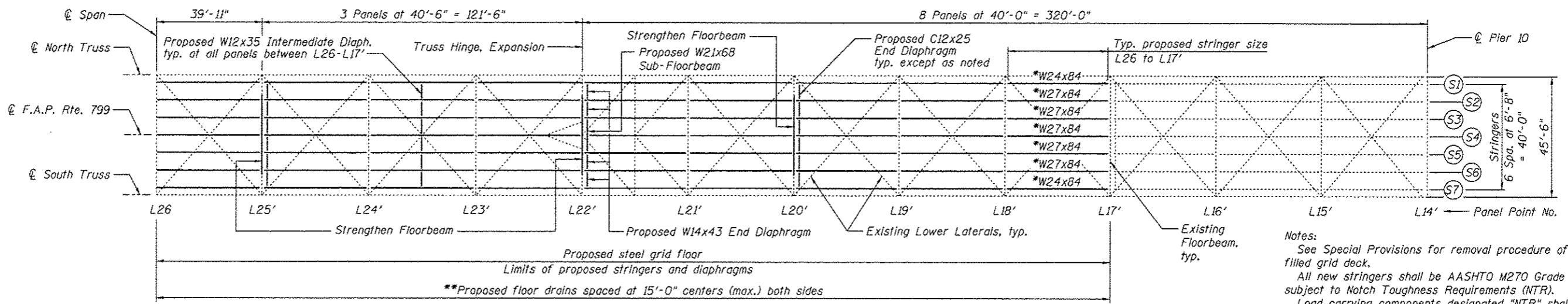

PART PLAN - SPAN 10

* Composite full length

** Adjust floor drains to clear existing obstructions and proposed grid deck bars. Maintain 15'-0" max. spacing.

Notes:
 See Special Provisions for removal procedure of existing filled grid deck.
 All new stringers shall be AASHTO M270 Grade 50 and subject to Notch Toughness Requirements (NTR).
 Load carrying components designated "NTR" shall conform to the Impact Testing Requirement, Zone 2.
 Cost of proposed stringers shall be included in Furnishing and Erecting Structural Steel.
 For stringer shear stud details, see sheet S15.
 For diaphragm and sub-floorbeam details, see sheet S24.
 See sheets S26 and S27 for required conduit hanger modifications.



USER NAME :	DESIGNED - YSS	REVISED
	CHECKED - ZJB	REVISED
PLOT SCALE :	DRAWN - PRC	REVISED
PLOT DATE : 03/20/2014	CHECKED - YSS	REVISED

STATE OF ILLINOIS
 DEPARTMENT OF TRANSPORTATION

MAIN SPANS GRID DECK DETAILS - 1
 S.N. 082-6001 MLK BRIDGE OVER MISSISSIPPI RIVER

SHEET NO. S14 OF S138 SHEETS

F.A.P. RTE. 799	SECTION 1BR, DRS-2	COUNTY ST. CLAIR	TOTAL SHEETS 156	SHEET NO. 32
CONTRACT NO. 76B03			ILLINOIS FED. AID PROJECT	

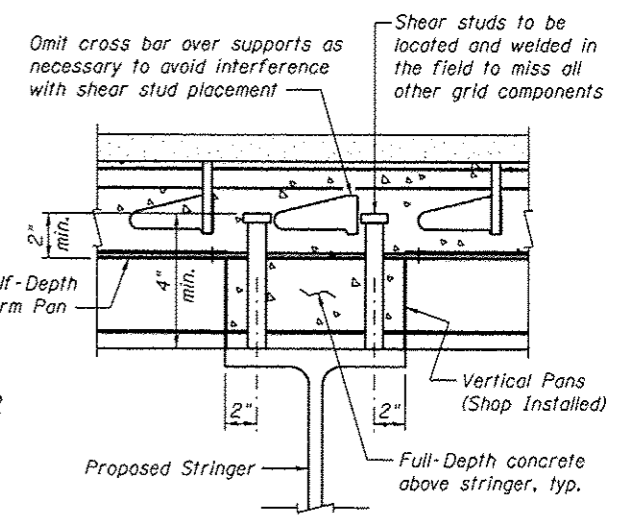
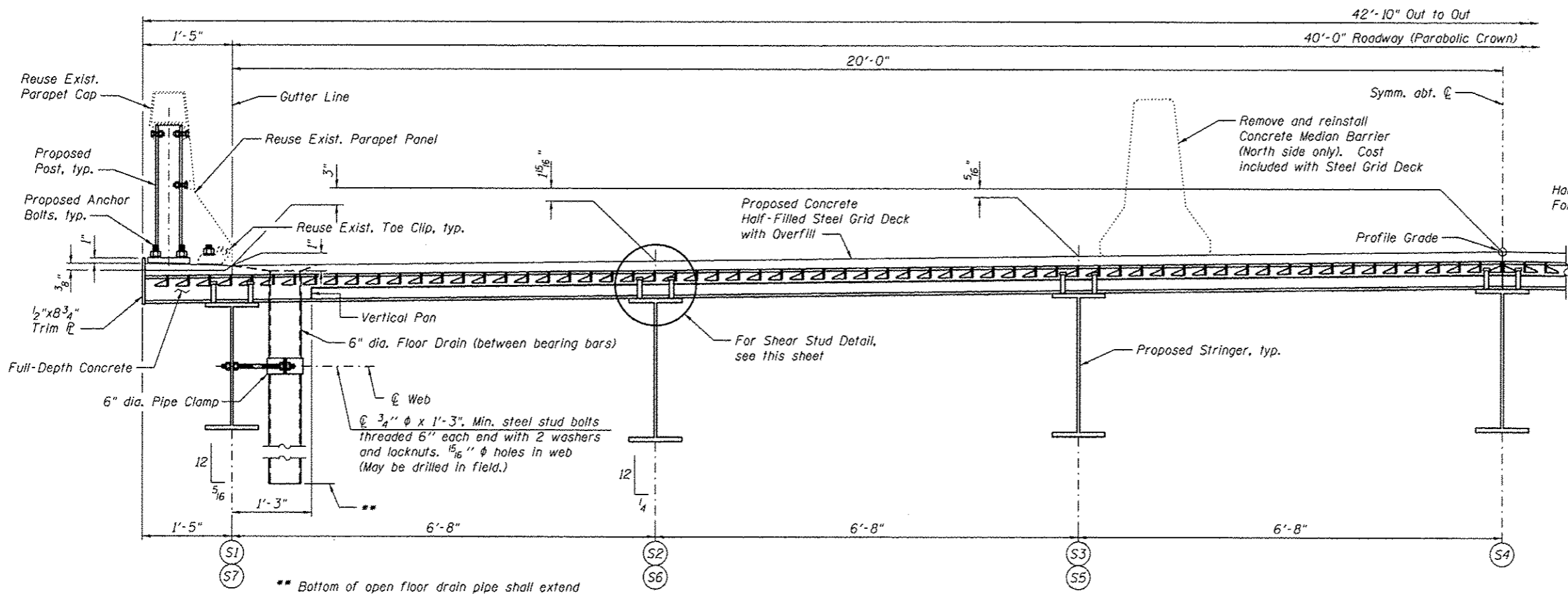

SHEAR CONNECTOR DETAIL

3/4" dia. granular or solid flux filled headed studs, automatically end welded to flange (19,740 req'd.)

** Bottom of open floor drain pipe shall extend 3" minimum below floorbeams at south gutter line, 3" minimum below telephone conduit hangers at north gutter line.

TYPICAL CROSS SECTION

Fabricate steel grid deck units to match crown of roadway

* Shear stud spa. at 5" max. along top of proposed W27x84 stringer and spa. at 10" max. along top of proposed W24x84 stringer.

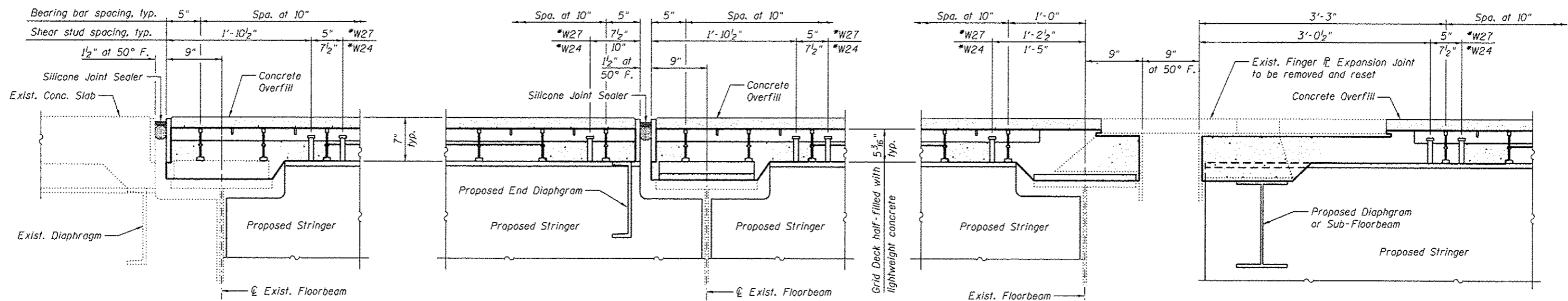

**EXPANSION JOINT AT L17
L17' (OPPOSITE HAND)**

**EXPANSION JOINT AT L20, L22 AND L25
L25' AND L20' (OPPOSITE HAND)**

EXPANSION JOINT AT L22'

Notes:
 Grid deck panel shall be adjusted to proper elevation through the use of built-in leveling bolts or shims.
 For grid deck floor system details, see sheet S16.
 For silicone joint sealer details, see sheet S16.
 For floor drain details, see sheet S17.
 For parapet and post details, see sheet S33.
 For finger plate expansion joint, see sheet S104.



USER NAME :	DESIGNED - YSS	REVISED
PLOT SCALE :	CHECKED - ZJB	REVISED
PLOT DATE :	DRAWN - PRC	REVISED
	CHECKED - YSS	REVISED

STATE OF ILLINOIS
DEPARTMENT OF TRANSPORTATION

MAIN SPANS GRID DECK DETAILS - 2
S.N. 082-6001 MLK BRIDGE OVER MISSISSIPPI RIVER

F.A.P. RTE.	SECTION	COUNTY	TOTAL SHEETS	SHEET NO.
799	1BR, DRS-2	ST. CLAIR	156	33
			CONTRACT NO. 76B03	
ILLINOIS FED. AID PROJECT				

SHEET NO. S15 OF S138 SHEETS

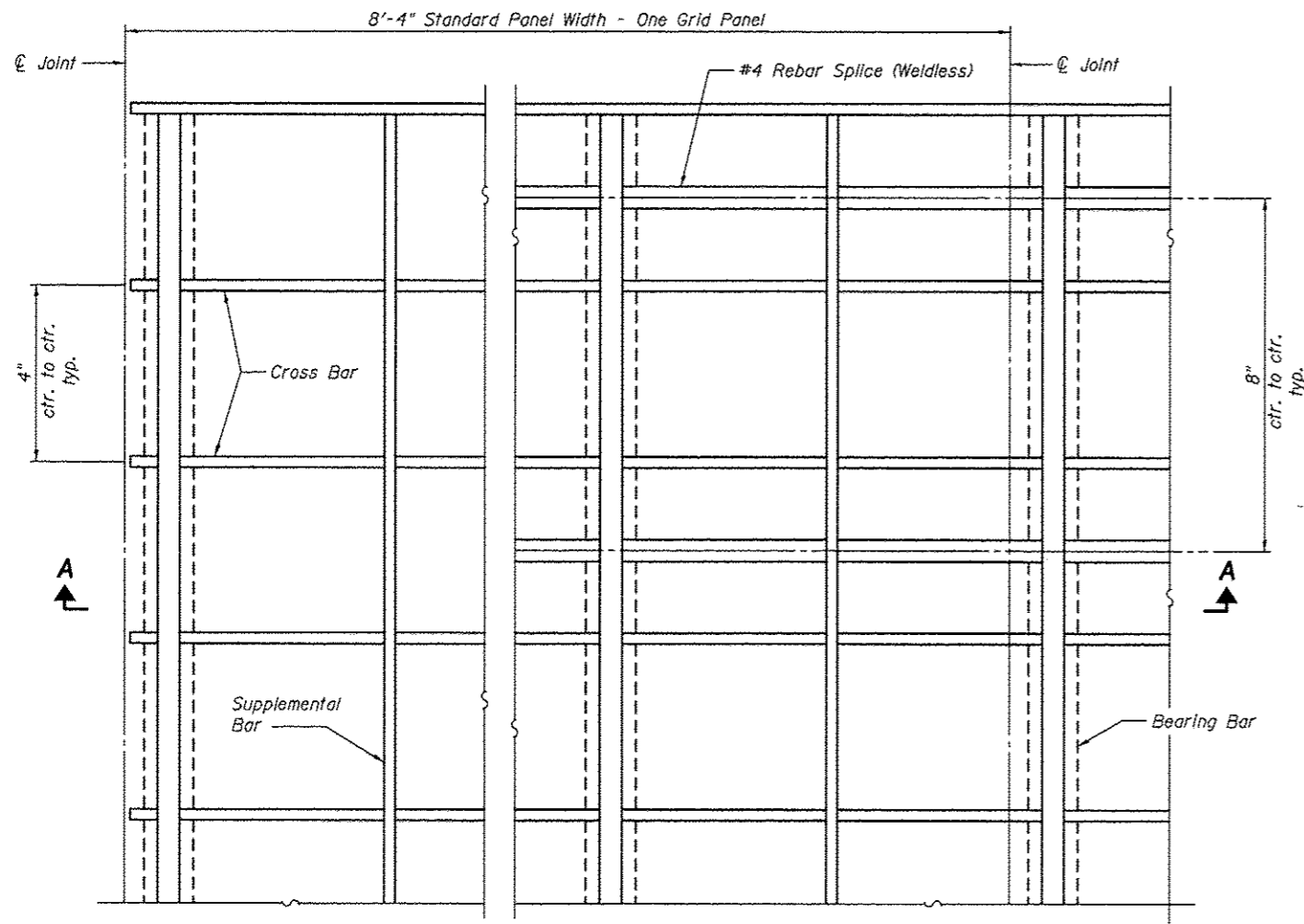

GRID DECK FLOOR SYSTEM

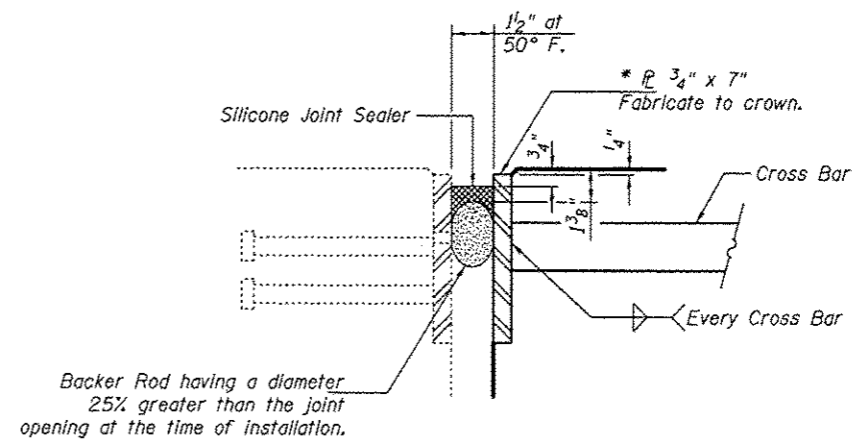

**SILICONE JOINT SEALER DETAIL
AT L17 AND L17'**

* Furnish in segments of 20 ft. maximum length. Maximum space between installed segments shall be 3/16". Seal space with Silicone Sealant suitable for Structural Steel. After fabrication, all surfaces of the steel R shall be galvanized in accordance with the Steel Grid Deck Special Provision. Cost of the plate shall be included with Steel Grid Deck.

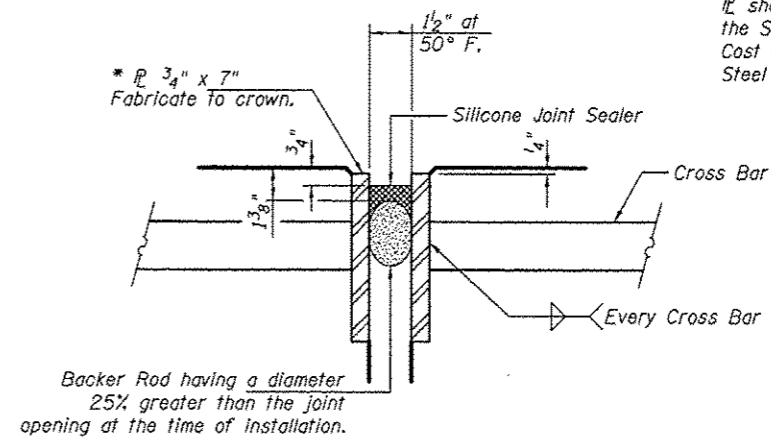

**SILICONE JOINT SEALER DETAIL
AT L20, L22, L25, L25' AND L20'**

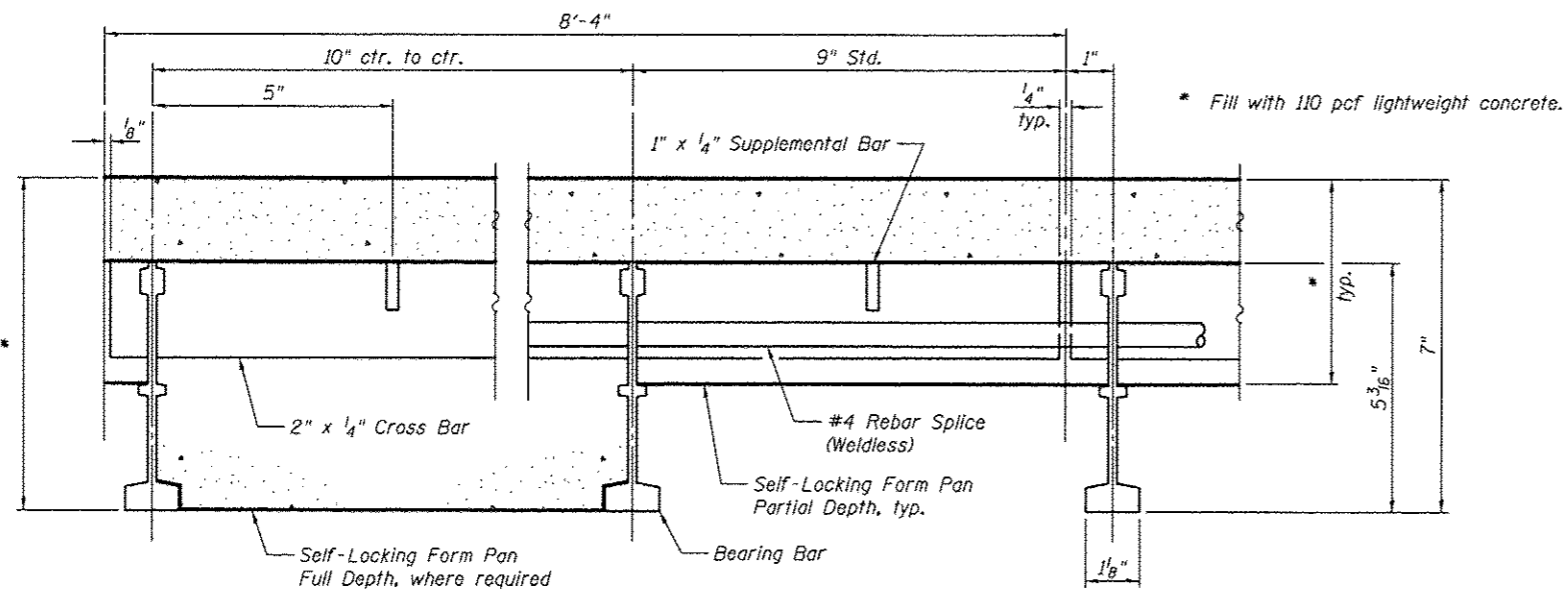

SECTION A-A

Notes:
Grid deck rebar splice, cross bar and supplementary bar sizes shown are minimums, see Special Provisions.
Grid deck panel widths may be adjusted to meet the distance requirements of the grid deck between roadway expansion devices.
Grid deck material shall be AASHTO M270 Grade 50.
Reinforcing bar shall be AASHTO M31 Grade 60.
See Steel Grid Deck Special Provision for additional information related to this work.

BILL OF MATERIAL

Item	Unit	Total
Steel Grid Deck	Sq. Ft.	31,026
Bridge Deck Grooving	Sq. Yd.	3058
Silicone Joint Sealer, 1.5"	Foot	300
Floor Drains	Each	100



USER NAME =	DESIGNED - YSS	REVISED
	CHECKED - ZJB	REVISED
PLOT SCALE =	DRAWN - PRC	REVISED
PLOT DATE = 03/28/2014	CHECKED - YSS	REVISED

STATE OF ILLINOIS
DEPARTMENT OF TRANSPORTATION

MAIN SPANS GRID DECK DETAILS - 3
S.N. 082-6001 MLK BRIDGE OVER MISSISSIPPI RIVER

SHEET NO. S16 OF S138 SHEETS

F.A.P. RTE.	SECTION	COUNTY	TOTAL SHEETS	SHEET NO.
799	1BR, DRS-2	ST. CLAIR	156	34
ILLINOIS FED. AID PROJECT			CONTRACT NO. 76B03	

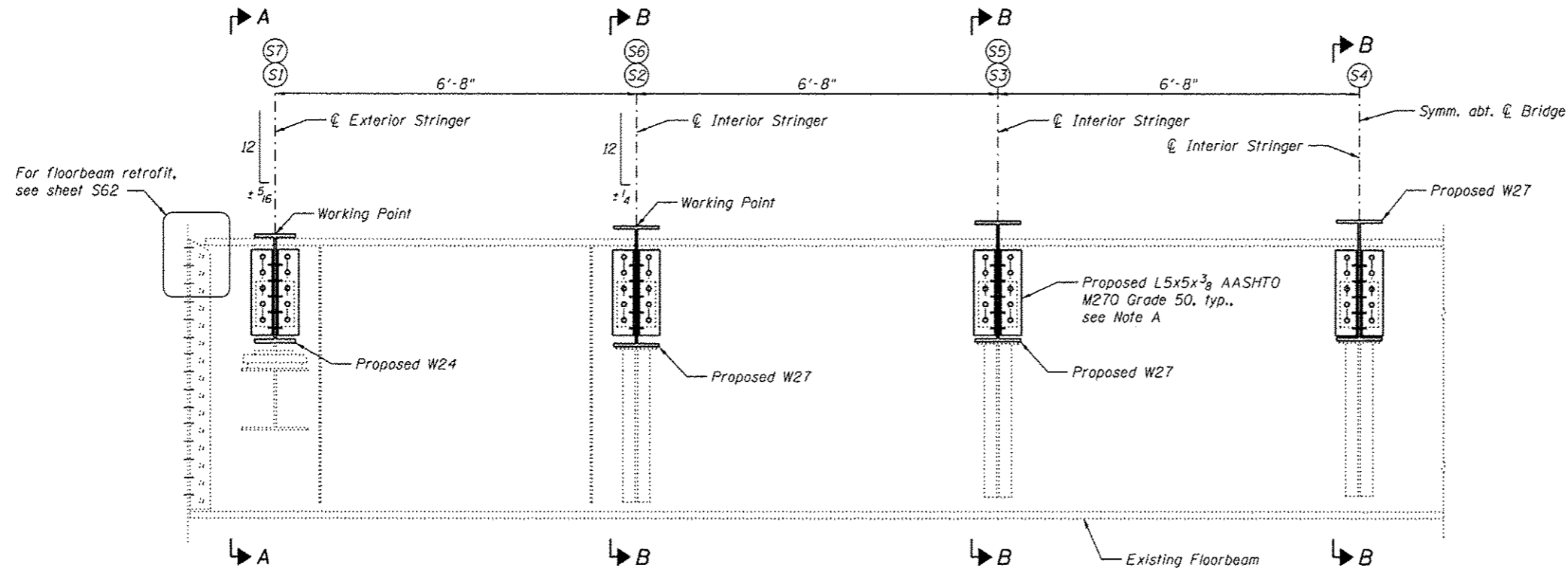

ELEVATION - FLOORBEAM L17 (SHOWN)
ELEVATION - FLOORBEAM L17' (SIMILAR)

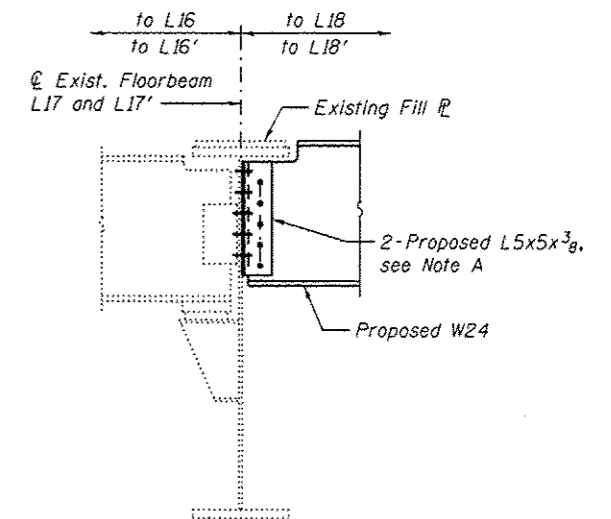

SECTION A-A

Note A:
 Field drill holes using existing holes as template. Remainder of holes may be shop or field drilled.

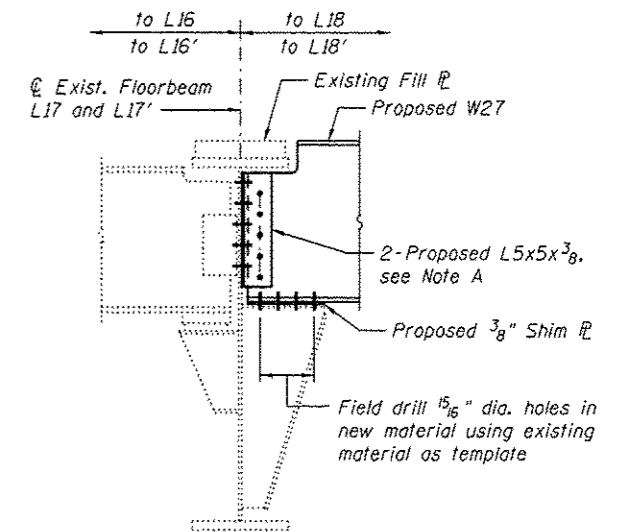

SECTION B-B

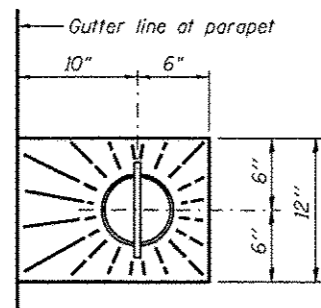

TOP PLAN

Cut grid deck cross and supplemental bars as required for placing anchor bolts. Do not cut bearing bars.

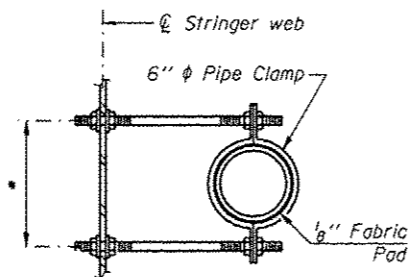

SECTION THRU PIPE AT STRINGER CONNECTION

*Dimension as required by Pipe Clamp

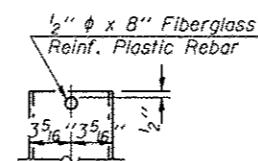

FIBERGLASS PIPE

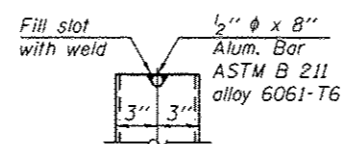

ALUMINUM TUBE

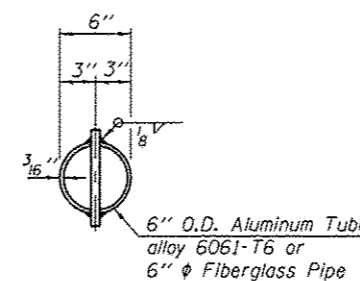

TOP PLAN (Showing Aluminum Tube)

FLOOR DRAIN DETAILS

Floor Drain Notes:
 The exterior surfaces of the floor drains shall be painted with the finish coat as specified in the special provisions for Cleaning and Painting New Metal Structures. The exterior surfaces of the drains shall be cleaned according to Society of Protective Coatings Spec. SSPC-SP1 prior to painting.
 Fiberglass pipe shall conform to ASTM D 2996, with short-time rupture strength hoop tensile stress of 30,000 p.s.i. minimum.
 Galvanize clamping device according to AASHTO M232. Cost of clamping device and inserts is included with Floor Drains.

Note:
 Cost of stringer connection angles and shim plates shall be included in Furnishing and Erecting Structural Steel.



USER NAME *	DESIGNED - YSS	REVISED
	CHECKED - ZJB	REVISED
PLOT SCALE *	DRAWN - PRC	REVISED
PLOT DATE 05/02/2014	CHECKED - YSS	REVISED

STATE OF ILLINOIS
 DEPARTMENT OF TRANSPORTATION

MAIN SPANS GRID DECK FRAMING DETAILS - 1
 S.N. 082-6001 MLK BRIDGE OVER MISSISSIPPI RIVER

SHEET NO. S17 OF S138 SHEETS

F.A.P. RTE.	SECTION	COUNTY	TOTAL SHEETS	SHEET NO.
799	IBR. DRS-2	ST. CLAIR	156	35
CONTRACT NO. 76B03			ILLINOIS FED. AID PROJECT	

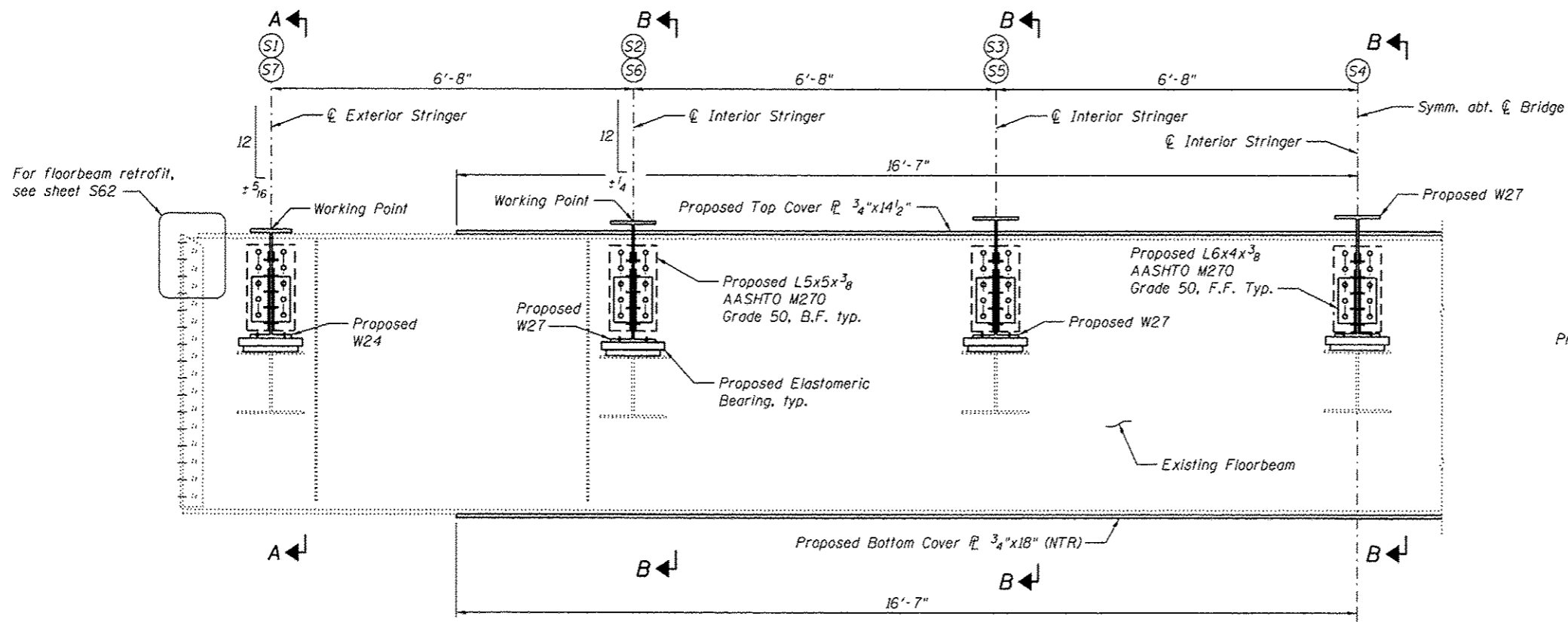

**ELEVATION - FLOORBEAM L20 AND L25 (SHOWN)
ELEVATION - FLOORBEAM L20' AND L25' (SIMILAR)**

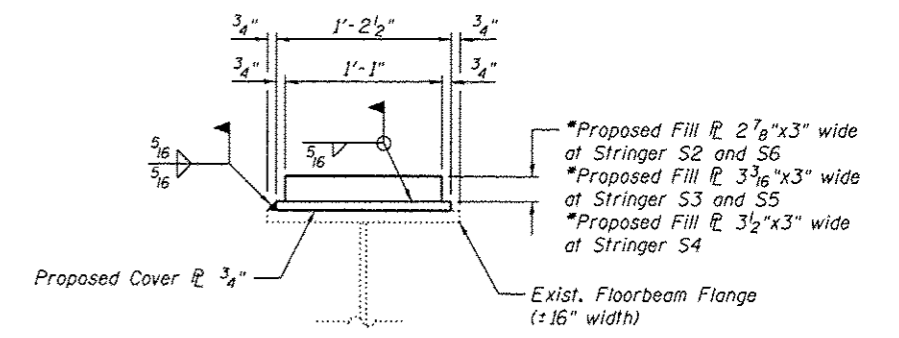

**DETAIL OF COVER PLATE AND FILL PLATE
at Stringer S2, S3, S4, S5 and S6**

* Remove existing fill $\bar{\bar{r}}$ and center proposed fill $\bar{\bar{r}}$ along $\bar{\bar{c}}$ stringer line, attach to proposed cover $\bar{\bar{r}}$

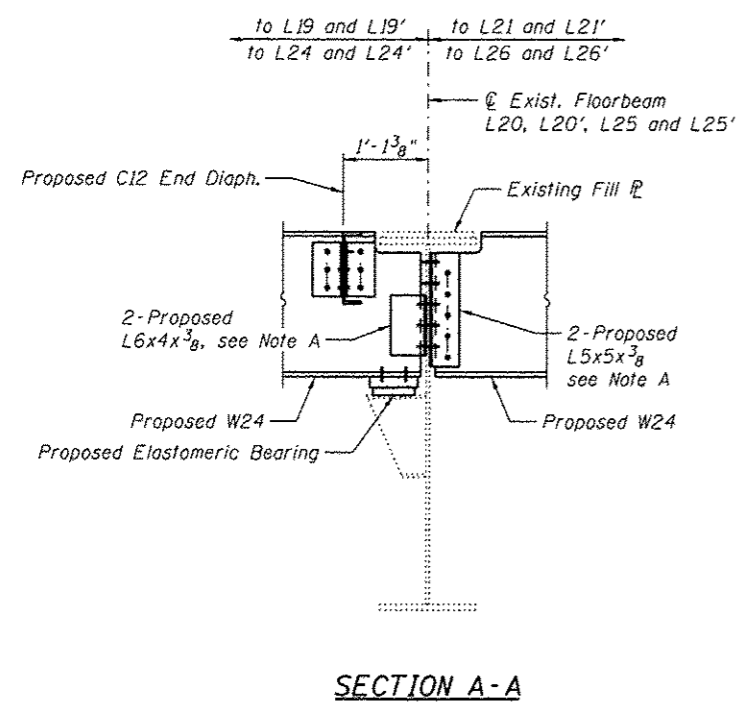

SECTION A-A

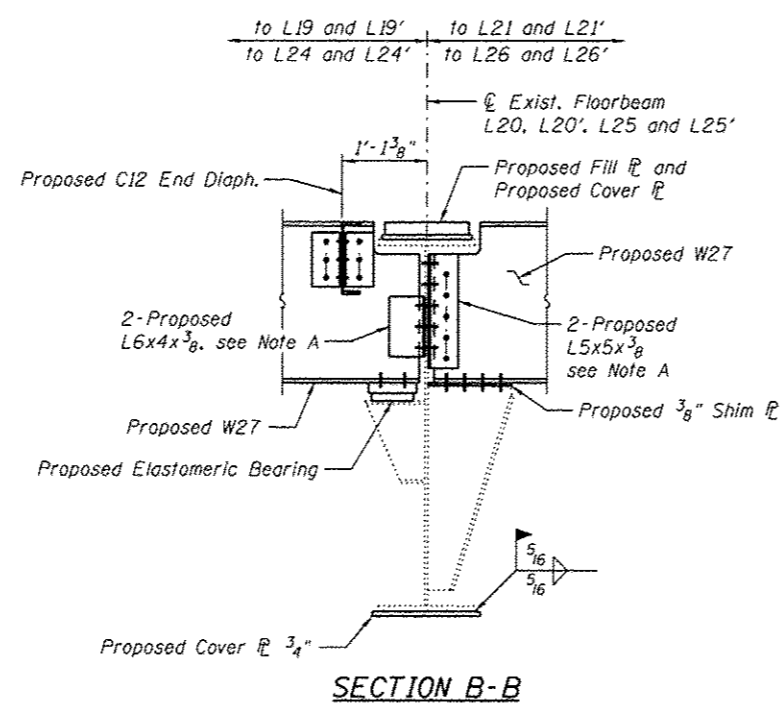

SECTION B-B

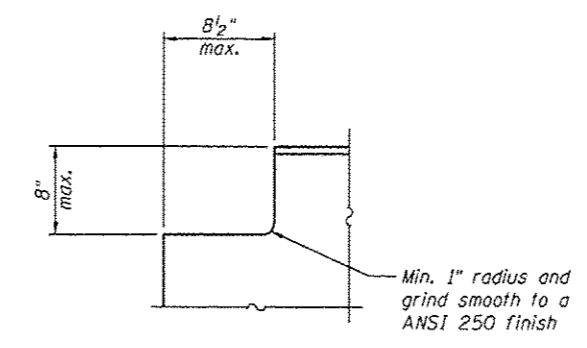

TYPICAL STRINGER COPING DETAIL

Note A:
Field drill holes using existing holes as template. Remainder of holes may be shop or field drilled.

Notes:
For diaphragm and connection angle details, see sheet S24.
For elastomeric bearing details and quantities, see sheet S23.
For additional cover plate details for floorbeam strengthening, see sheet S21.
Cost of stringer connection angles and shim plates shall be included in Furnishing and Erecting Structural Steel.
Cost of cover plates and fill plates shall be included in Structural Steel Repair.
Load carrying components designated "NTR" shall conform to the Impact Testing Requirement, Zone 2.

BILL OF MATERIAL

Item	Unit	Total
Structural Steel Repair	Pound	11,330



USER NAME: _____
DESIGNED - MEL/YSS
CHECKED - COB/ZJB
PLOT SCALE: _____
DRAWN - PRC
PLOT DATE: 05/02/2014
CHECKED - MEL/YSS
REVISED

**STATE OF ILLINOIS
DEPARTMENT OF TRANSPORTATION**

**MAIN SPANS GRID DECK FRAMING DETAILS - 2
S.N. 082-6001 MLK BRIDGE OVER MISSISSIPPI RIVER**

SHEET NO. S18 OF S138 SHEETS

F.A.R. RTE.	SECTION	COUNTY	TOTAL SHEETS	SHEET NO.
799	1BR, ORS-2	ST. CLAIR	156	36

CONTRACT NO. 76B03
ILLINOIS FED. AID PROJECT

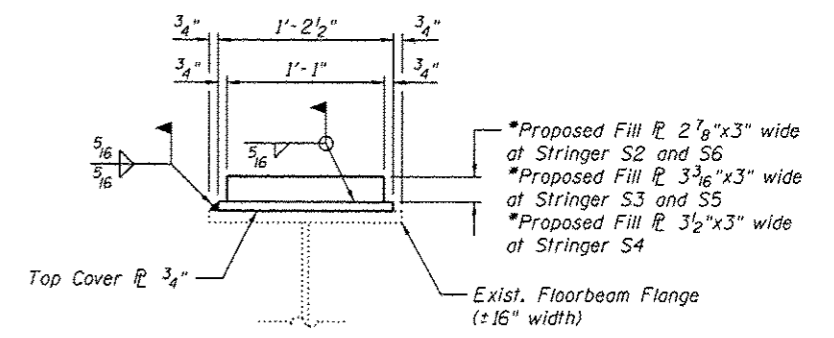
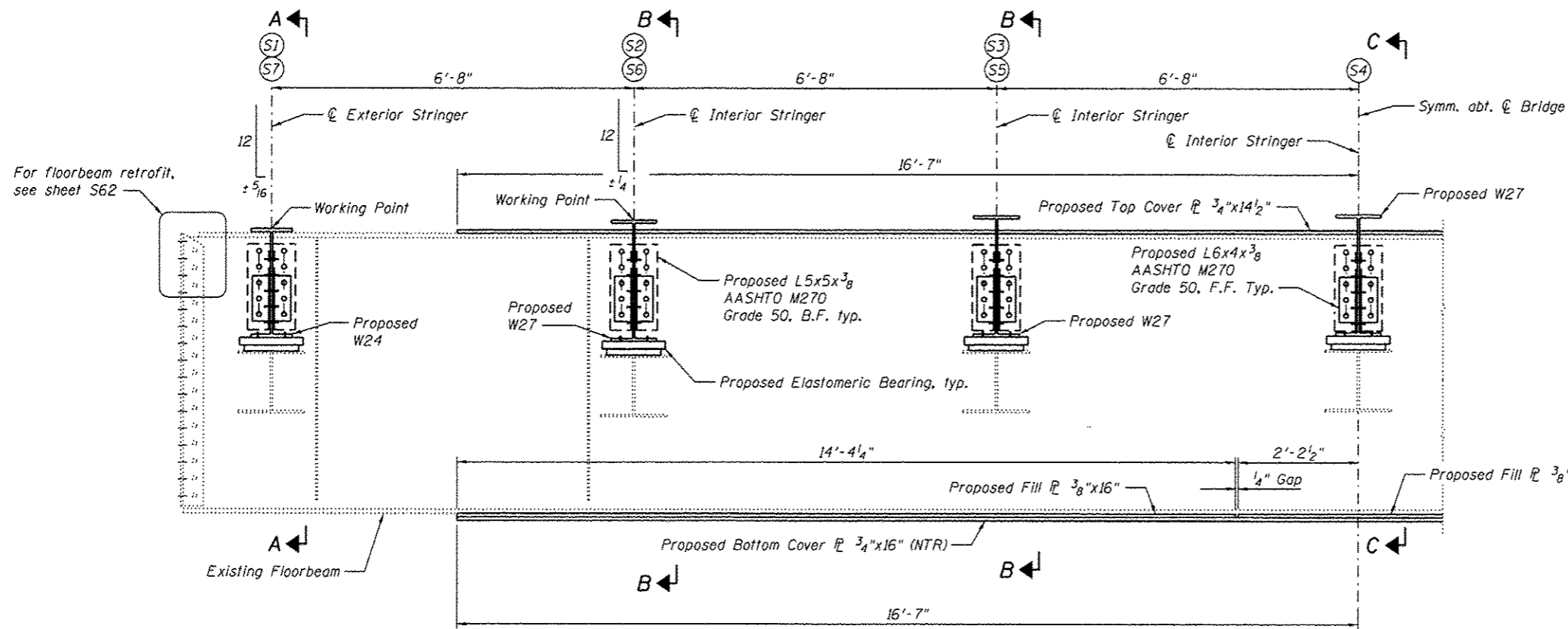

DETAIL OF COVER PLATE AND FILL PLATE
at Stringer S2, S3, S4, S5 and S6

* Remove existing fill \bar{L} and center proposed fill \bar{L} along \bar{C} stringer line, attach to proposed top cover \bar{L}

ELEVATION - FLOORBEAM L22

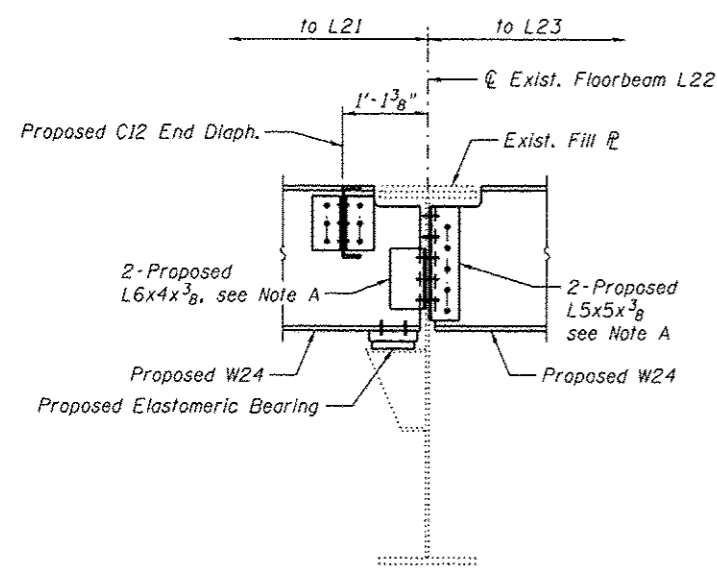

SECTION A-A

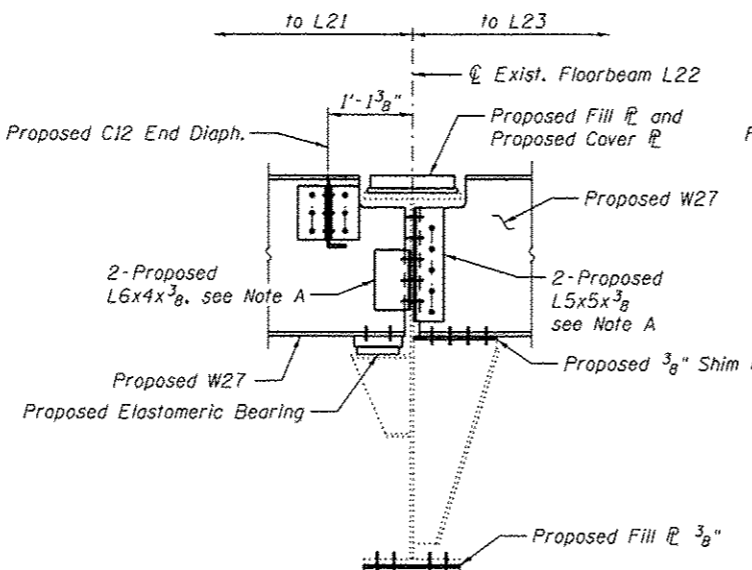

SECTION B-B

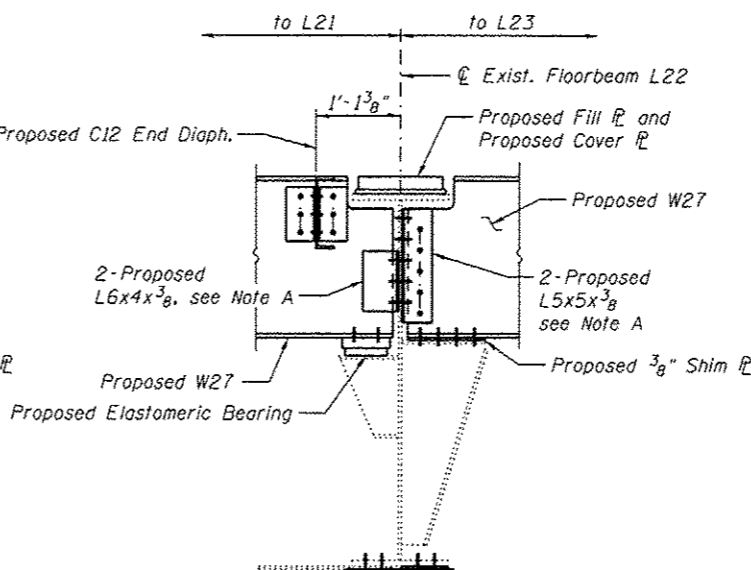

SECTION C-C

Note A:
Field drill holes using existing holes as template. Remainder of holes may be shop or field drilled.

Notes:
For diaphragm and connection angle details, see sheet S24.
For elastomeric bearing details and quantities, see sheet S23.
For additional cover plate details for floorbeam strengthening, see sheet S21.
Cost of stringer connection angles and shim plates shall be included in Furnishing and Erecting Structural Steel.
Cost of cover plates and fill plates shall be included in Structural Steel Repair.
Load carrying components designated "NTR" shall conform to the Impact Testing Requirement, Zone 2.

BILL OF MATERIAL

Item	Unit	Total
Structural Steel Repair	Pound	3,430



USER NAME *	DESIGNED - MEL/YSS	REVISED
	CHECKED - COB/ZJB	REVISED
PLOT SCALE *	DRAWN - PRC	REVISED
PLOT DATE * 05/02/2014	CHECKED - MEL/YSS	REVISED

STATE OF ILLINOIS
DEPARTMENT OF TRANSPORTATION

MAIN SPANS GRID DECK FRAMING DETAILS - 3
S.N. 082-6001 MLK BRIDGE OVER MISSISSIPPI RIVER

SHEET NO. S19 OF S138 SHEETS

F.A.P. RTE. 799	SECTION 1BR, ORS-2	COUNTY ST. CLAIR	TOTAL SHEETS 156	SHEET NO. 37
			CONTRACT NO. 76B03	
ILLINOIS FED. AID PROJECT				

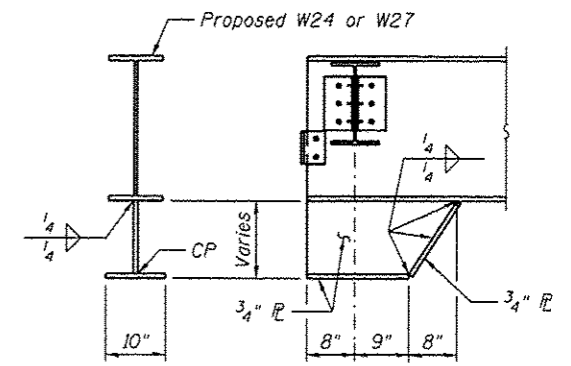
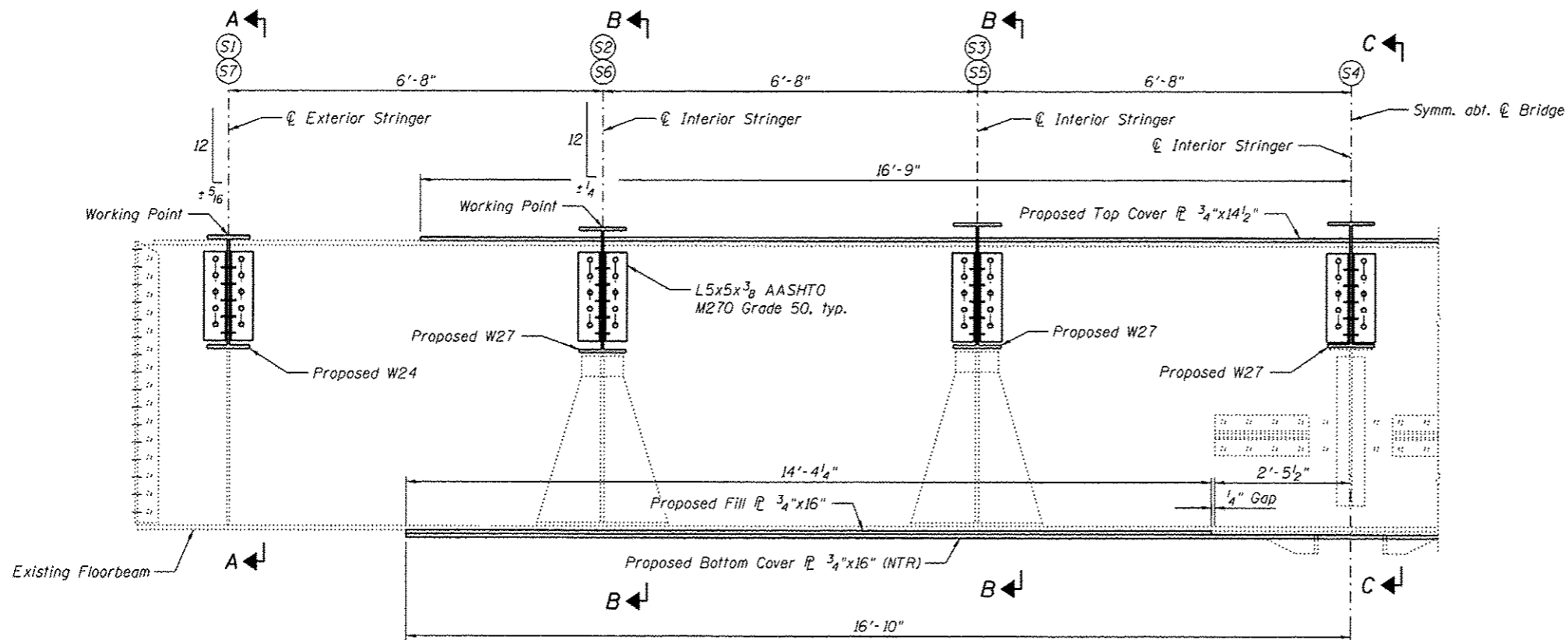

STRINGER UPSET WELDMENT DETAIL

at Stringers 1-3 and 5-7
L22' end (expansion side) only

Note:
All material for weldments shall be
AASHTO M270 Grade 50.

ELEVATION - FLOORBEAM L22'

Existing Finger Plate Expansion Joint to be removed and reset, see sheet S104.
Use existing top flange holes for expansion joint as a template for field drilling
holes in top cover plate.

Note A:
Field drill holes using existing holes as template.
Remainder of holes may be shop or field drilled.

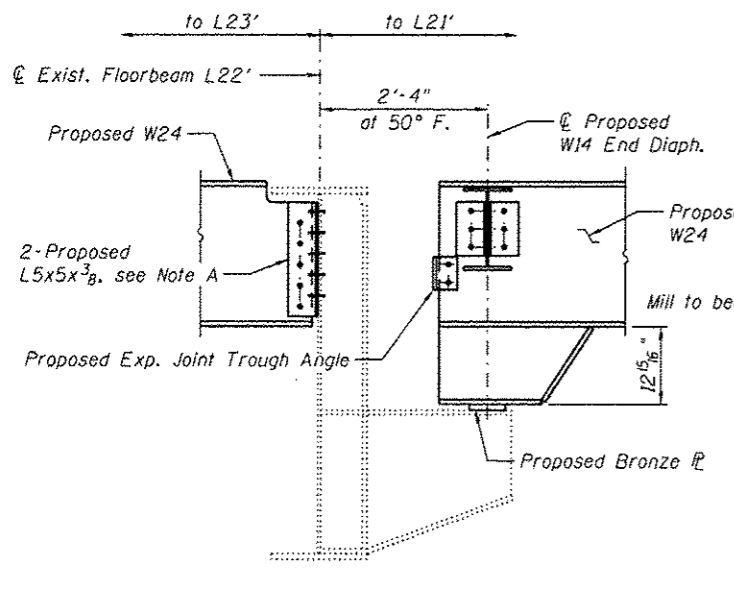

SECTION A-A

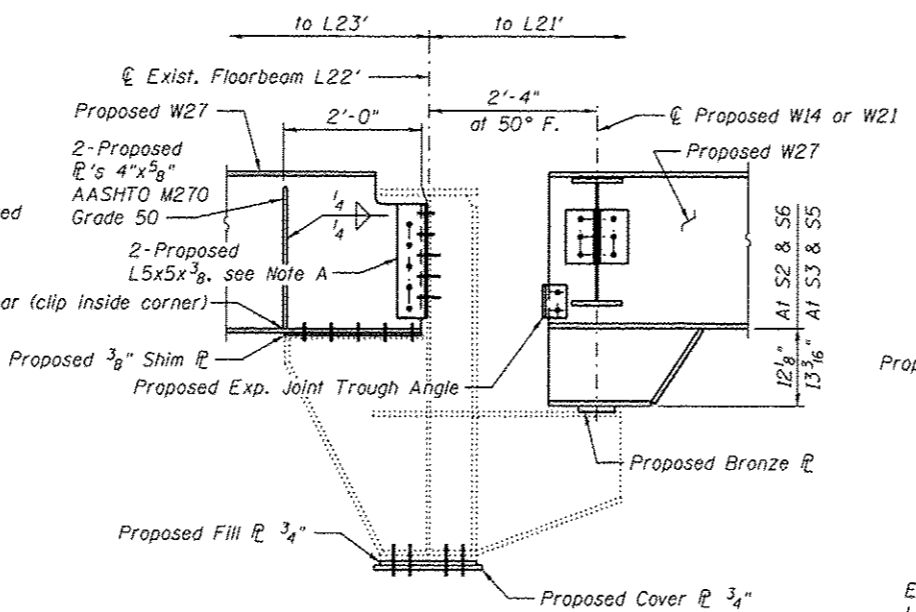

SECTION B-B

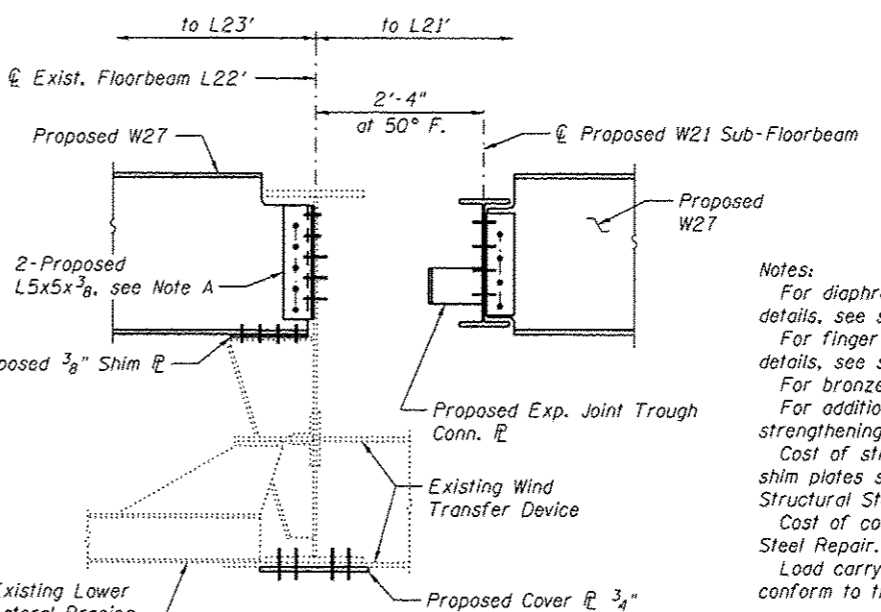

SECTION C-C

Notes:
For diaphragm, sub-floorbeam and connection angle
details, see sheet S24.
For finger plate expansion joint trough connection
details, see sheet S104.
For bronze plate detail, see sheet S23.
For additional cover plate details for floorbeam
strengthening, see sheet S22.
Cost of stringer upset weldment, connection angles and
shim plates shall be included in Furnishing and Erecting
Structural Steel.
Cost of cover plates shall be included in Structural
Steel Repair.
Load carrying components designated "NTR" shall
conform to the Impact Testing Requirement, Zone 2.

BILL OF MATERIAL

Item	Unit	Total
Structural Steel Repair	Pound	3,940



USER NAME *	DESIGNED - MEL/YSS	REVISED
	CHECKED - CDB/ZJB	REVISED
PLOT SCALE *	DRAWN - PRC	REVISED
PLOT DATE * 05/02/2014	CHECKED - MEL/YSS	REVISED

STATE OF ILLINOIS
DEPARTMENT OF TRANSPORTATION

MAIN SPANS GRID DECK FRAMING DETAILS - 4
S.N. 082-6001 MLK BRIDGE OVER MISSISSIPPI RIVER

SHEET NO. S20 OF S138 SHEETS

F.A.P. RTE.	SECTION	COUNTY	TOTAL SHEETS	SHEET NO.
799	IBR, DRS-2	ST. CLAIR	156	38
CONTRACT NO. 76B03				
ILLINOIS FED. AID PROJECT				

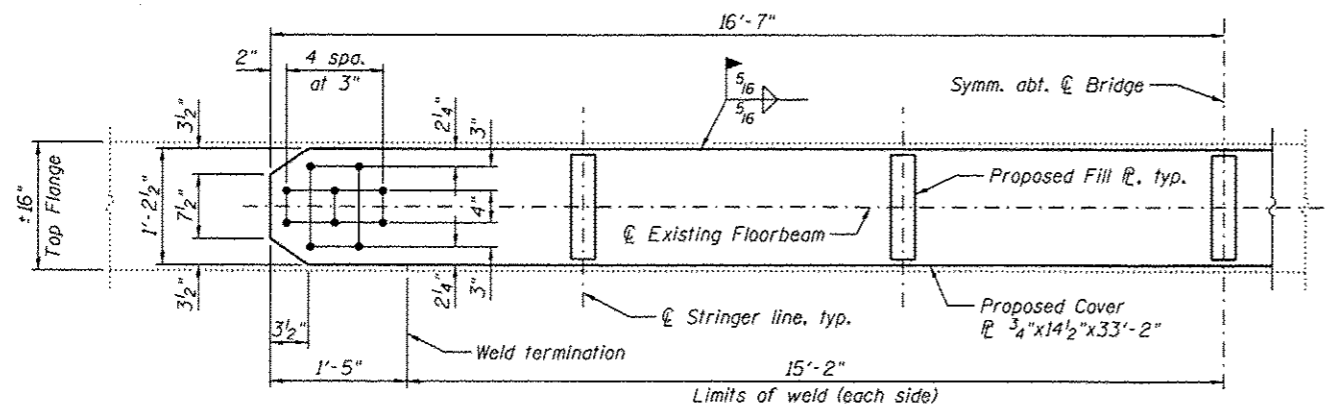

**TOP FLANGE STRENGTHENING
AT FLOORBEAM L20, L20', L22, L25 AND L25'**

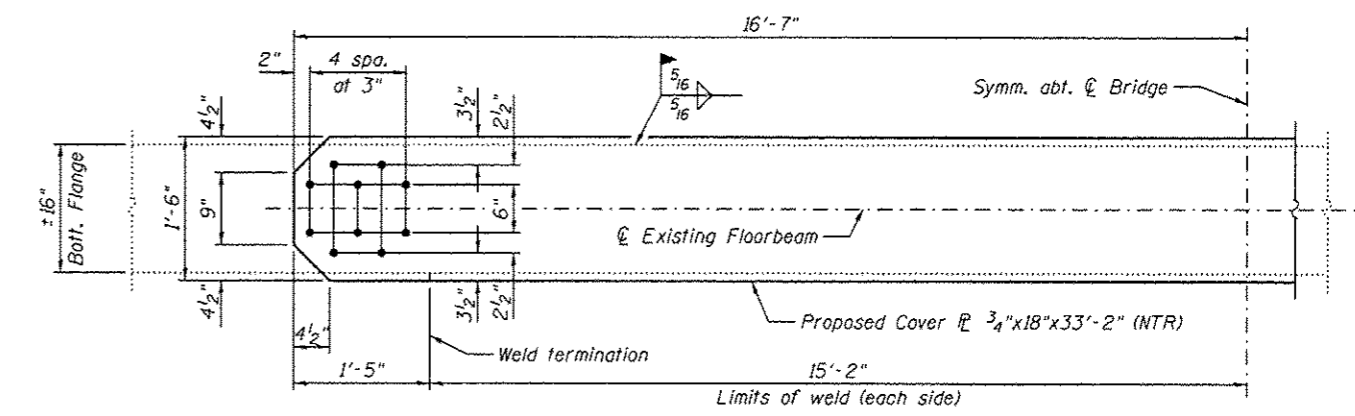

**BOTTOM FLANGE STRENGTHENING
AT FLOORBEAM L20, L20', L25 AND L25'**

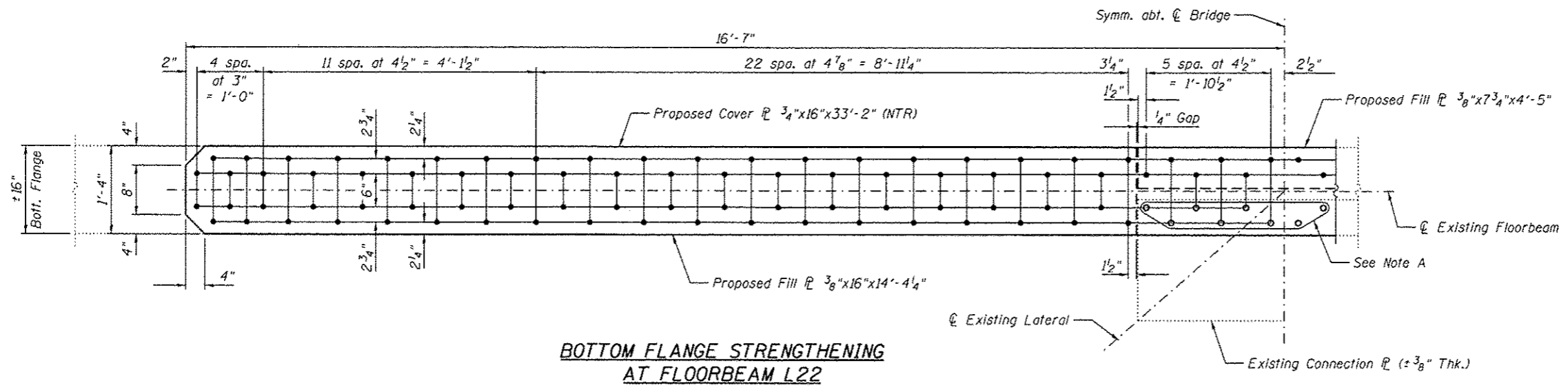

**BOTTOM FLANGE STRENGTHENING
AT FLOORBEAM L22**

Note A:
Field drill holes using existing holes as template.
Remainder of holes may be shop or field drilled.

Note:
Load carrying components designed as "NTR" shall conform to the Impact Testing Requirement, Zone 2.



USER NAME *	DESIGNED - MEL	REVISED
	CHECKED - YSS	REVISED
PLOT SCALE *	DRAWN - PRC	REVISED
PLOT DATE * 05/02/2014	CHECKED - MEL	REVISED

STATE OF ILLINOIS
DEPARTMENT OF TRANSPORTATION

MAIN SPANS GRID DECK FRAMING DETAILS - 5
S.N. 082-6001 MLK BRIDGE OVER MISSISSIPPI RIVER

F.A.P. RTE.	SECTION	COUNTY	TOTAL SHEETS	SHEET NO.
799	1BR, DRS-2	ST. CLAIR	156	39
CONTRACT NO. 76B03				
ILLINOIS FED. AID PROJECT				

SHEET NO. S21 OF 5138 SHEETS

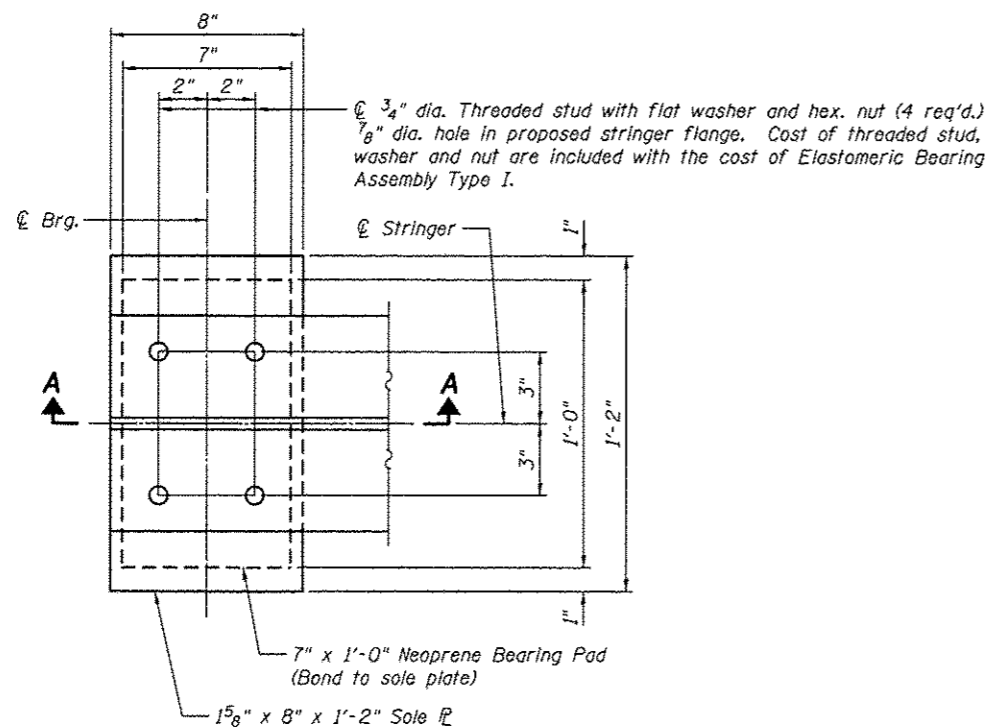

REMOVAL AND INSTALLATION OF STRINGER EXPANSION BEARING
Elastomeric Bearing Assembly Type I
(35 Required)

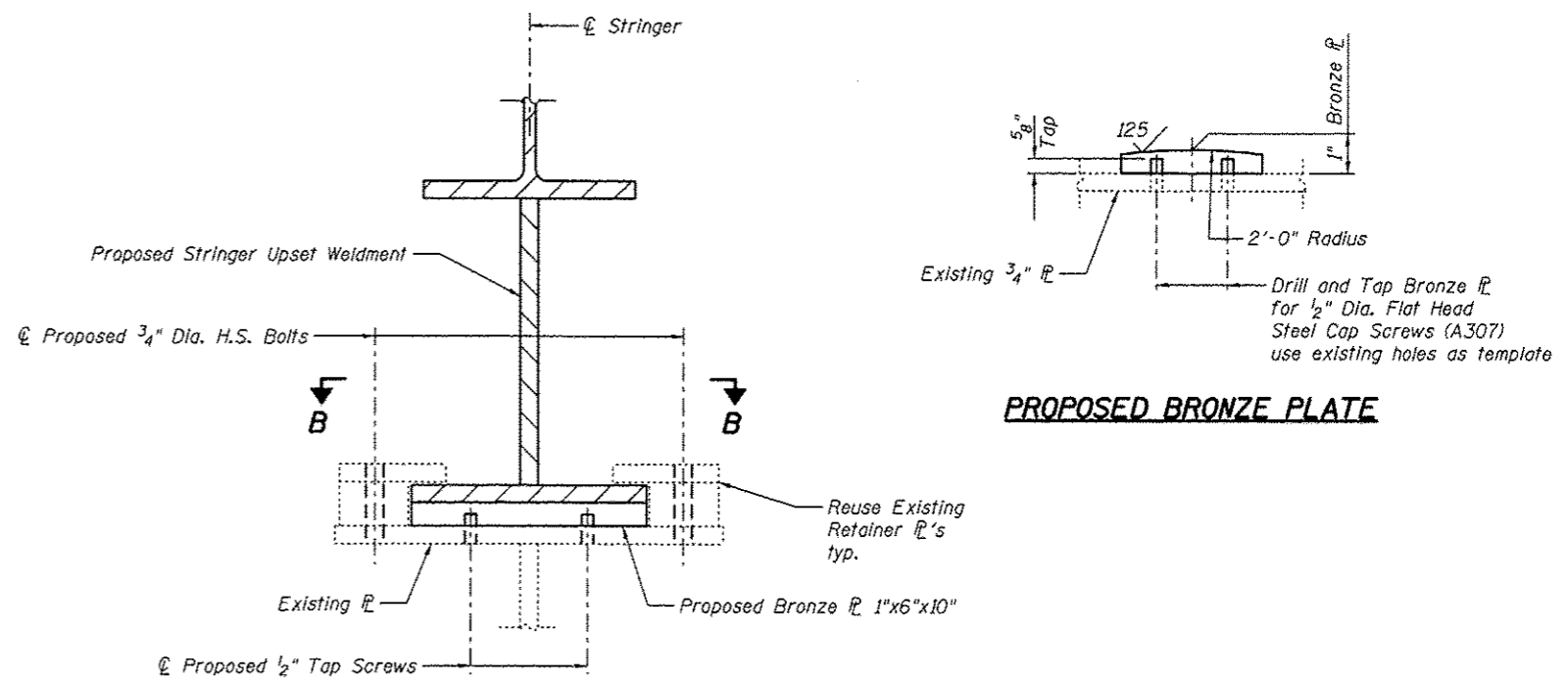

REMOVAL AND INSTALLATION OF BRONZE PLATES
(6 Required)

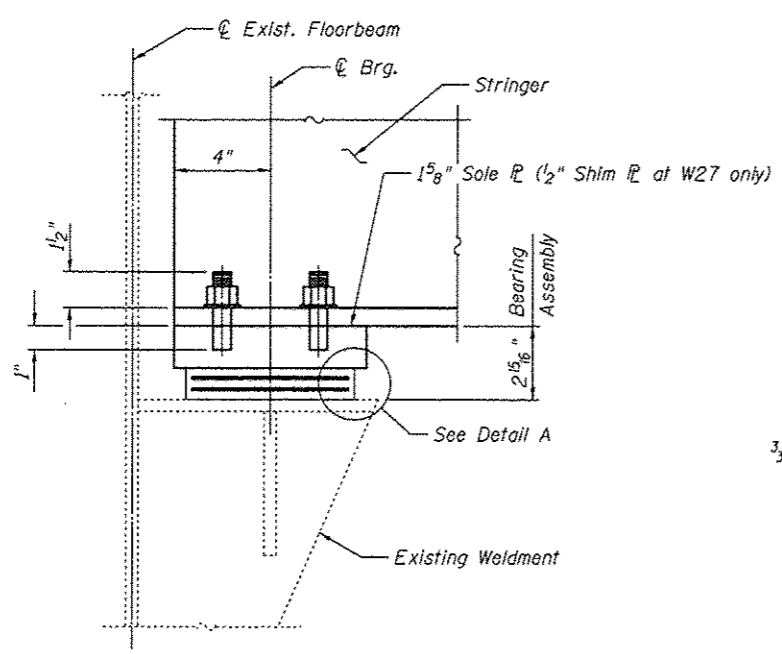

SECTION A-A

Note:
Shim plates shall not be placed under bearing assembly.

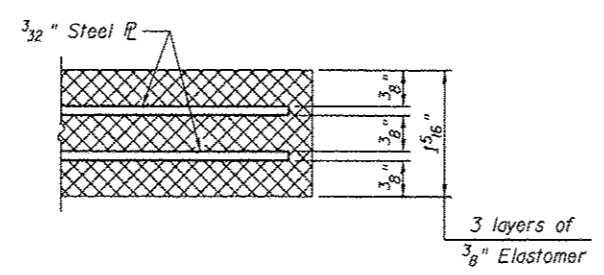

DETAIL A

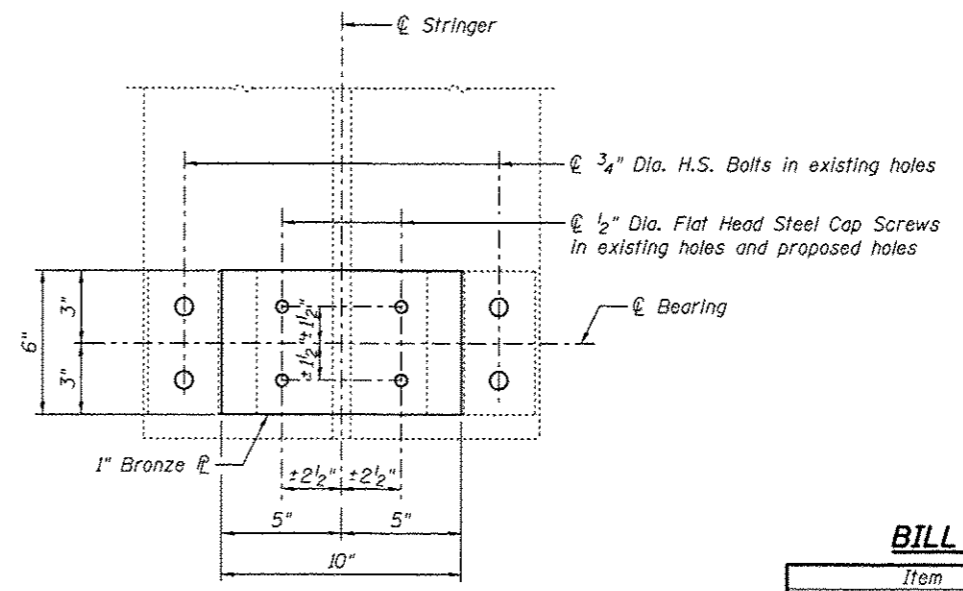

SECTION B-B
Stringer upset weldment not shown for clarity.

BILL OF MATERIAL

Item	Unit	Total
Elastomeric Bearing Assembly Type I	Each	35

Notes:
Bronze plates shall conform to ASTM B22. Cost of bronze plate and tap screw are included with the cost for Furnishing and Erecting Structural Steel.
For removal of existing expansion bearing and bronze plate, see Special Provision "Removal of Existing Filled Grid Deck".



USER NAME =	DESIGNED - YSS	REVISED
	CHECKED - ZJB	REVISED
PLOT SCALE =	DRAWN - PRC	REVISED
PLOT DATE = 03/20/2014	CHECKED - YSS	REVISED

STATE OF ILLINOIS
DEPARTMENT OF TRANSPORTATION

MAIN SPANS GRID DECK FRAMING DETAILS - 7
S.N. 082-6001 MLK BRIDGE OVER MISSISSIPPI RIVER

SHEET NO. S23 OF S138 SHEETS

F.A.P. RTE.	SECTION	COUNTY	TOTAL SHEETS	SHEET NO.
799	1BR, DRS-2	ST. CLAIR	136	41
ILLINOIS FED. AID PROJECT				

CONTRACT NO. 76B03

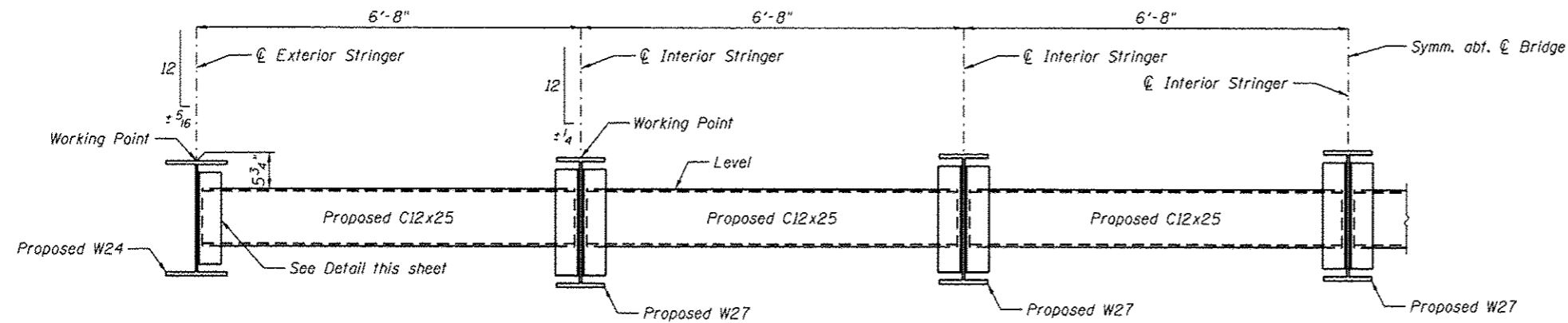

**TYPICAL INTERMEDIATE DIAPHRAGM
PANEL POINTS L17 THRU L17'**

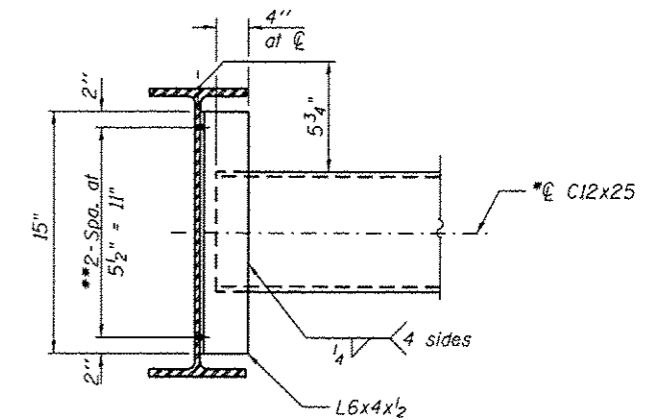

INTERMEDIATE DIAPHRAGM DETAIL

*C12x30 can be used as an alternate channel size. Alternate channels are permitted to facilitate material acquisition. Calculated weight of structural steel is based on the lighter section. The alternate, if utilized, shall be provided at no additional cost to the Department.

**5/16" dia. holes for 3/4" dia. H.S. bolts with 2 hardened washers for each bolt.

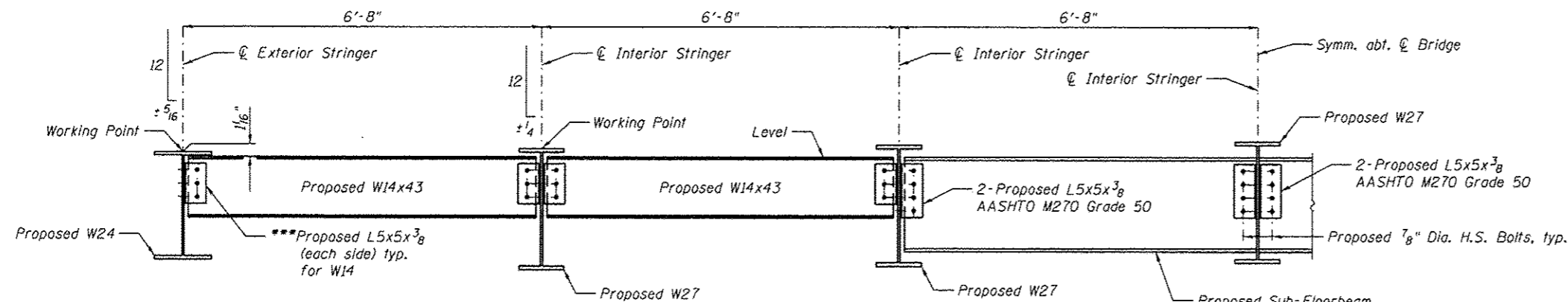

**END DIAPHRAGM
PANEL POINT L22'**

For expansion device stool mounting in top flange of proposed W14 and W21 use existing expansion device as template for field drilling of holes.

*** For connections to diaphragm webs provide 5/16" dia. holes in proposed angles and proposed diaphragm webs for 3/4" dia. H.S. bolts with 2 hardened washers for each bolt.

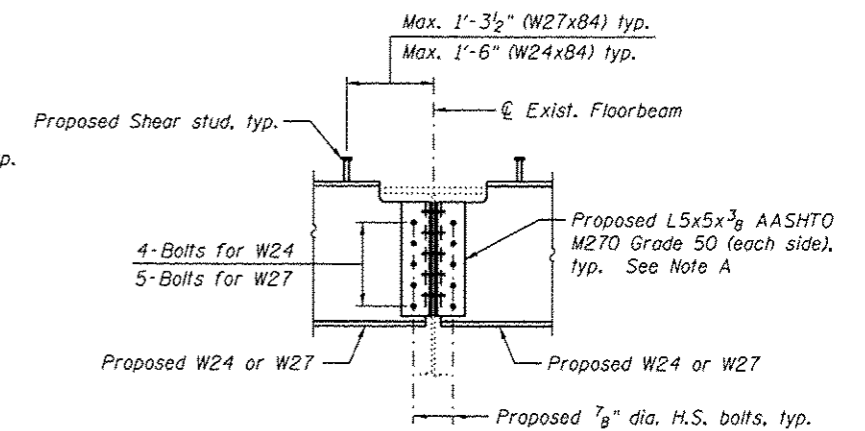

**STRINGER CONNECTION DETAIL
AT PANEL POINTS L18, L19, L21, L23,
L24, L26, L18', L19', L21', L23' AND L24'**

Note A:
Field drill holes using existing holes as template. Remainder of holes may be shop or field drilled.

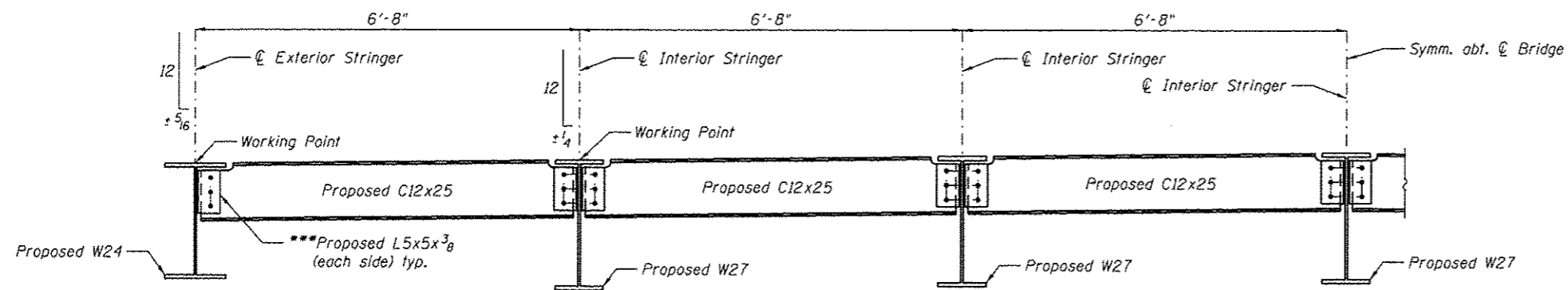

**TYPICAL END DIAPHRAGM
SPAN 10 - PANEL POINTS L20, L22 AND L25
SPAN 10 - PANEL POINTS L20' AND L25'**

Notes:
End diaphragms to be located as shown on floorbeam details or to match existing.
All bolted connections shown on this sheet shall be made with 3/4" dia. H.S. bolts unless otherwise noted.
Load carrying components designated "NTR" shall conform to the Impact Testing Requirement, Zone 2.
Cost of diaphragm, sub-floorbeam and connection angles shall be included in Furnishing and Erecting Structural Steel.



USER NAME *	DESIGNED - YSS	REVISED
PLOT SCALE *	CHECKED - ZJB	REVISED
PLOT DATE * 05/02/2014	DRAWN - PRC	REVISED
	CHECKED - YSS	REVISED

STATE OF ILLINOIS
DEPARTMENT OF TRANSPORTATION

MAIN SPANS GRID DECK FRAMING DETAILS - 8
S.N. 082-6001 MLK BRIDGE OVER MISSISSIPPI RIVER

SHEET NO. 524 OF 5138 SHEETS

F.A.P. RTE.	SECTION	COUNTY	TOTAL SHEETS	SHEET NO.
T99	1BR, DRS-2	ST. CLAIR	156	42
CONTRACT NO. 76B03				
ILLINOIS FED. AID PROJECT				

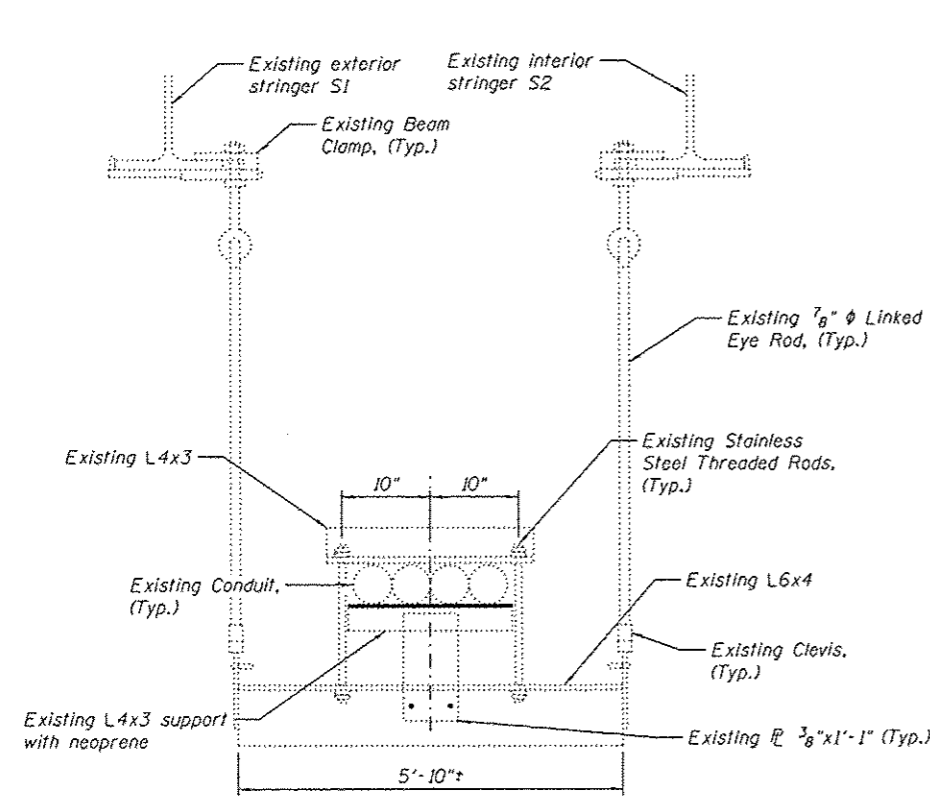

EXISTING CONFIGURATION
(Existing Hanger - H2)
(13 Locations)

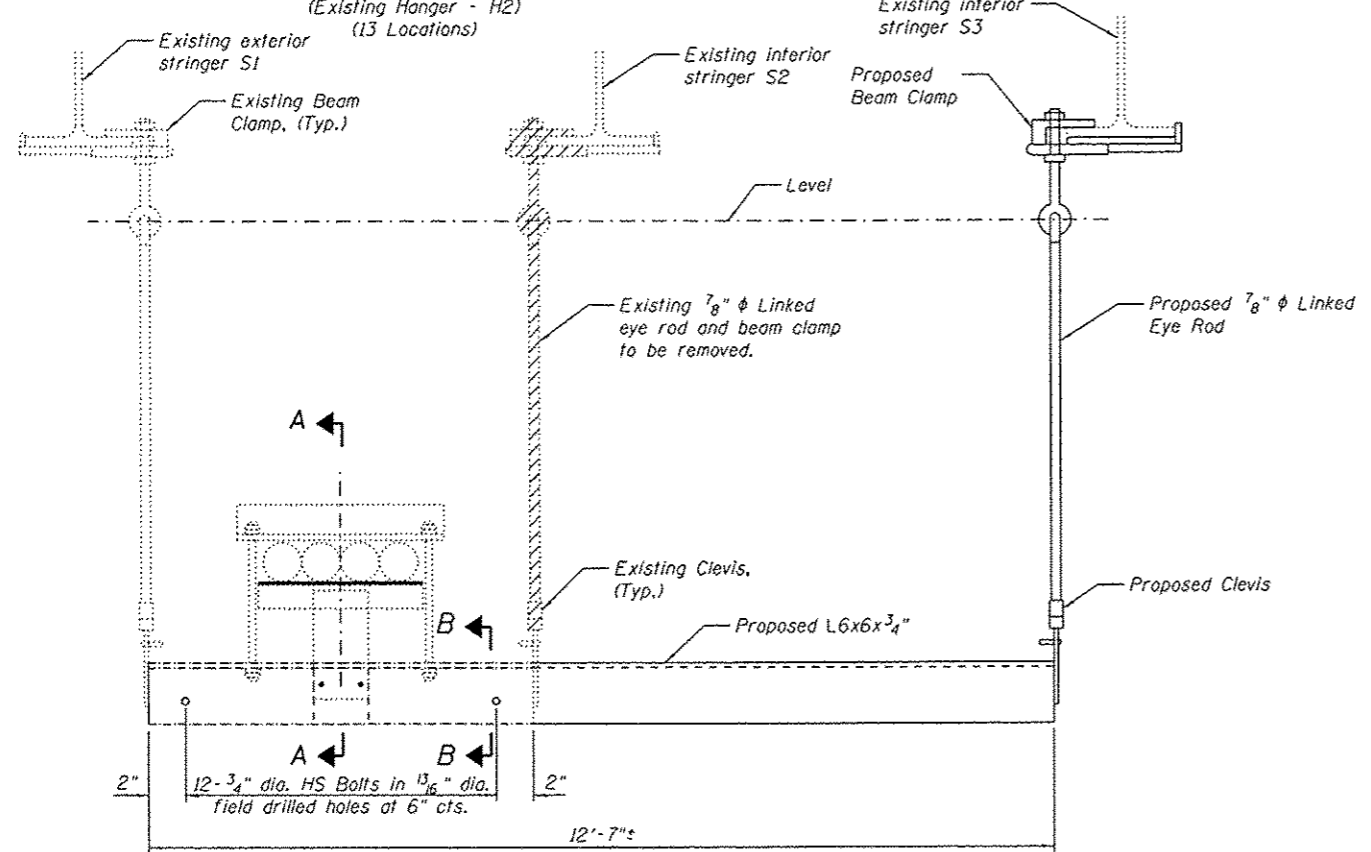

CONDUIT SUPPORT MODIFICATION

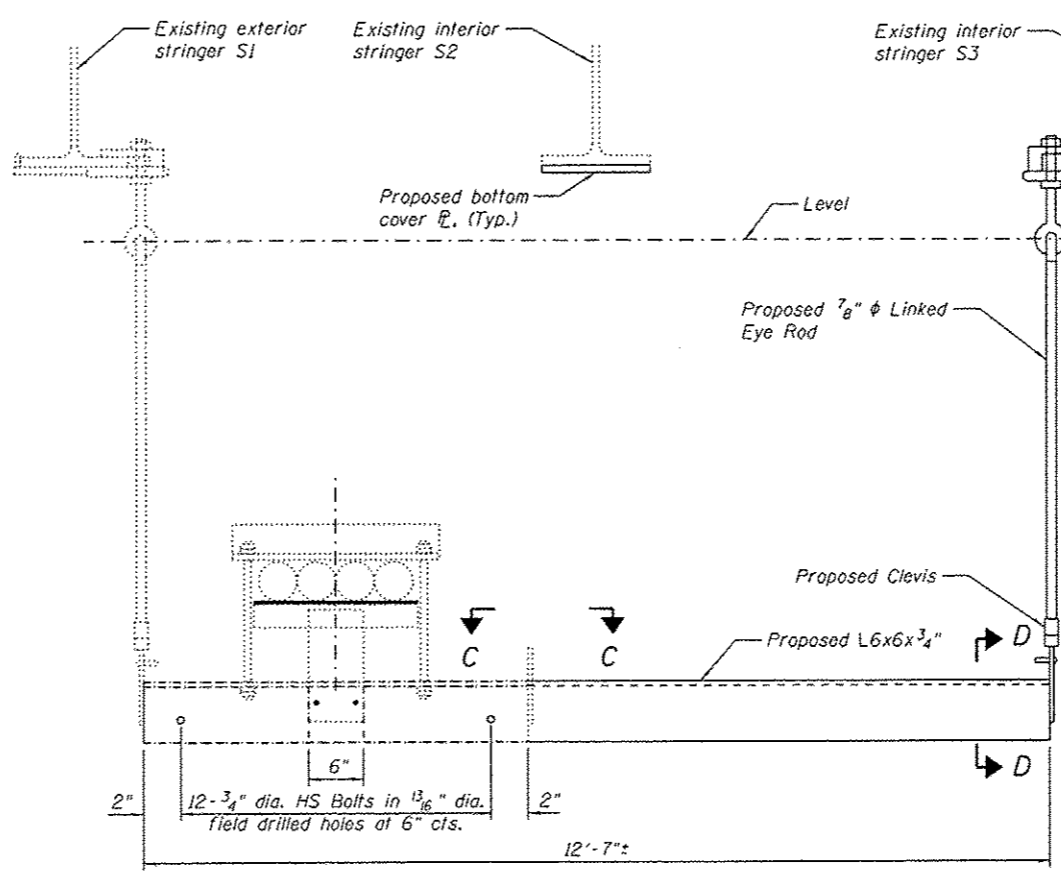

FINAL CONFIGURATION
(Modified Hanger - H2)
(13 Locations)

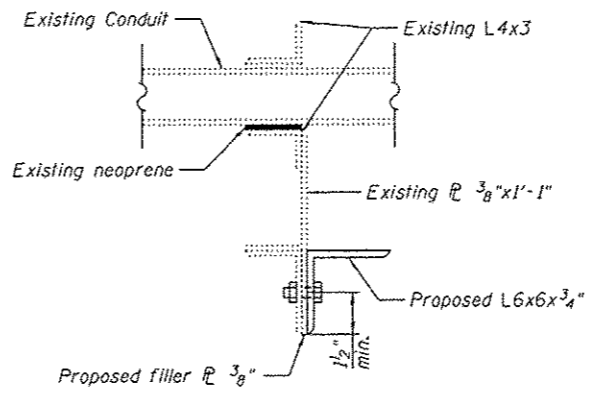

SECTION A-A

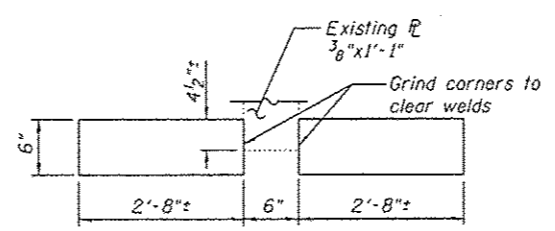

FILLER PLATES 3/8\"/>

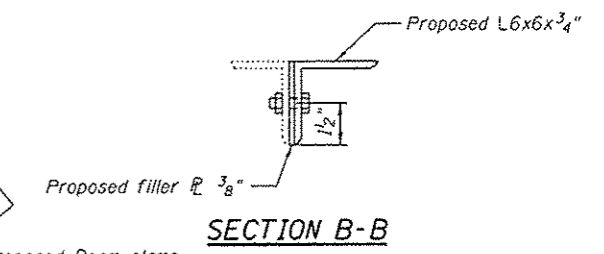

SECTION B-B

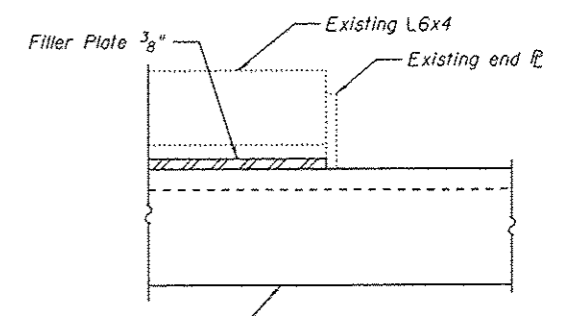

VIEW C-C

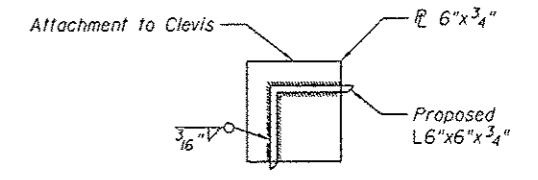

SECTION D-D

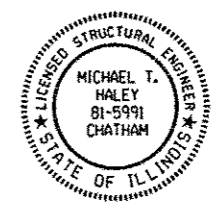

APPROVED
For Structural Adequacy Only

D. Carl Perry
Engineer of Bridges & Structures

Michael T. Haley 5-1-14
Date

Michael T. Haley
Licensed Structural Engineer
State of Illinois No. 81-5991
Expires 11/30/2014

MODIFICATION SEQUENCE FOR H2

1. Complete rehabilitation of interior stringer S3.
2. Install new L6x6x3/4\"/>

Notes:
The Contractor is to verify the existing dimensions prior to fabricating the support assembly. The existing details shown here are derived from the existing plans. It is intended to keep the utility conduit at the current elevation.
See sheets S026 and S027 for details of hangers H6 and H12.
See sheet S027 of S138 for locations of hangers, additional notes and bill of material.
See sheet S088 of S138 for details about painting proposed steel.

(Sheet 1 of 3)



USER NAME *	DESIGNED - JJA	REVISD -
FILE NAME *	CHECKED - TBP	REVISD -
PLOT SCALE *	DRAWN - AJF	REVISD -
PLOT DATE *	CHECKED - VPT	REVISD -

DESIGNED - JJA	REVISD -
CHECKED - TBP	REVISD -
DRAWN - AJF	REVISD -
CHECKED - VPT	REVISD -

STATE OF ILLINOIS
DEPARTMENT OF TRANSPORTATION

MAIN SPANS CONDUIT HANGER MODIFICATION DETAILS
S.N. 082-6001 MLK BRIDGE OVER MISSISSIPPI RIVER

SHEET NO. S025 OF S138 SHEETS

F.A.P. RATE	SECTION	COUNTY	TOTAL SHEETS	SHEET NO.
799	1BR, DRS-2	ST. CLAIR	156	043
			CONTRACT NO. 76B03	
ILLINOIS FED. AID PROJECT				

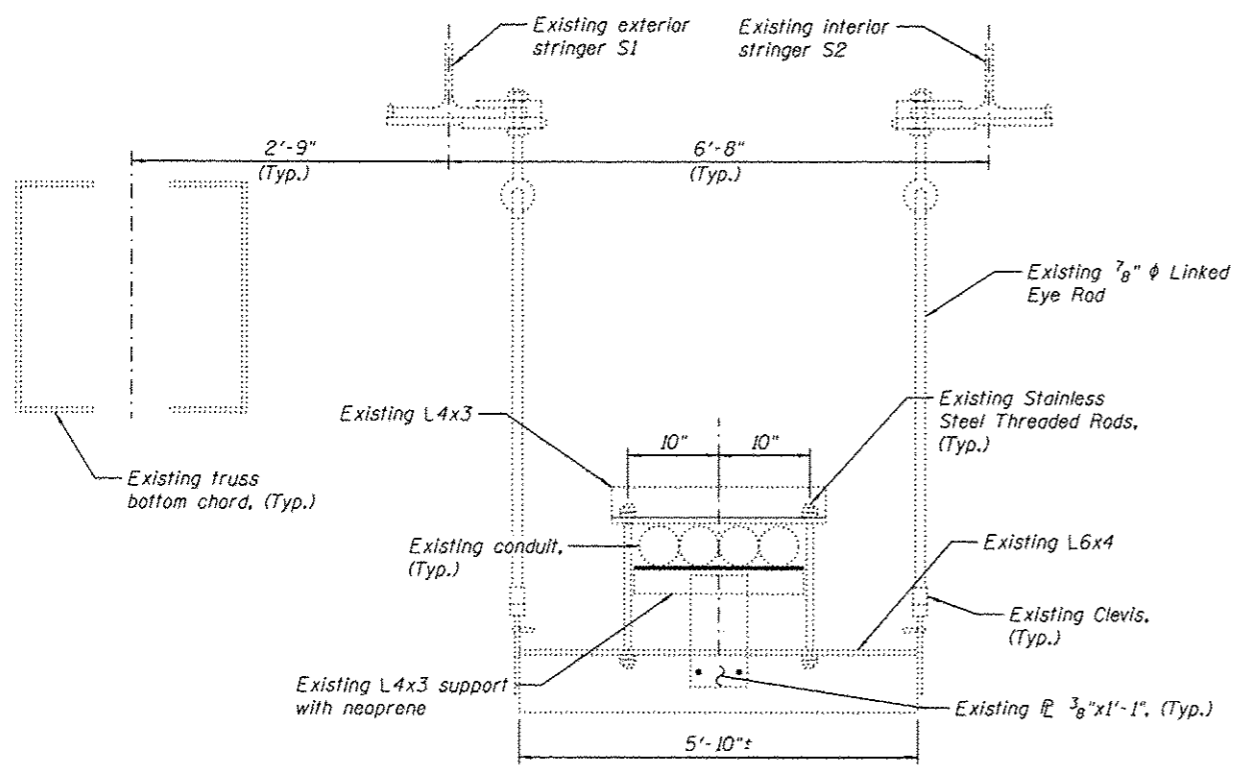

EXISTING CONFIGURATION
 (Existing Hangers - H6 & H12)
 (Total 40 Locations, 4-H6 and 36-H12)

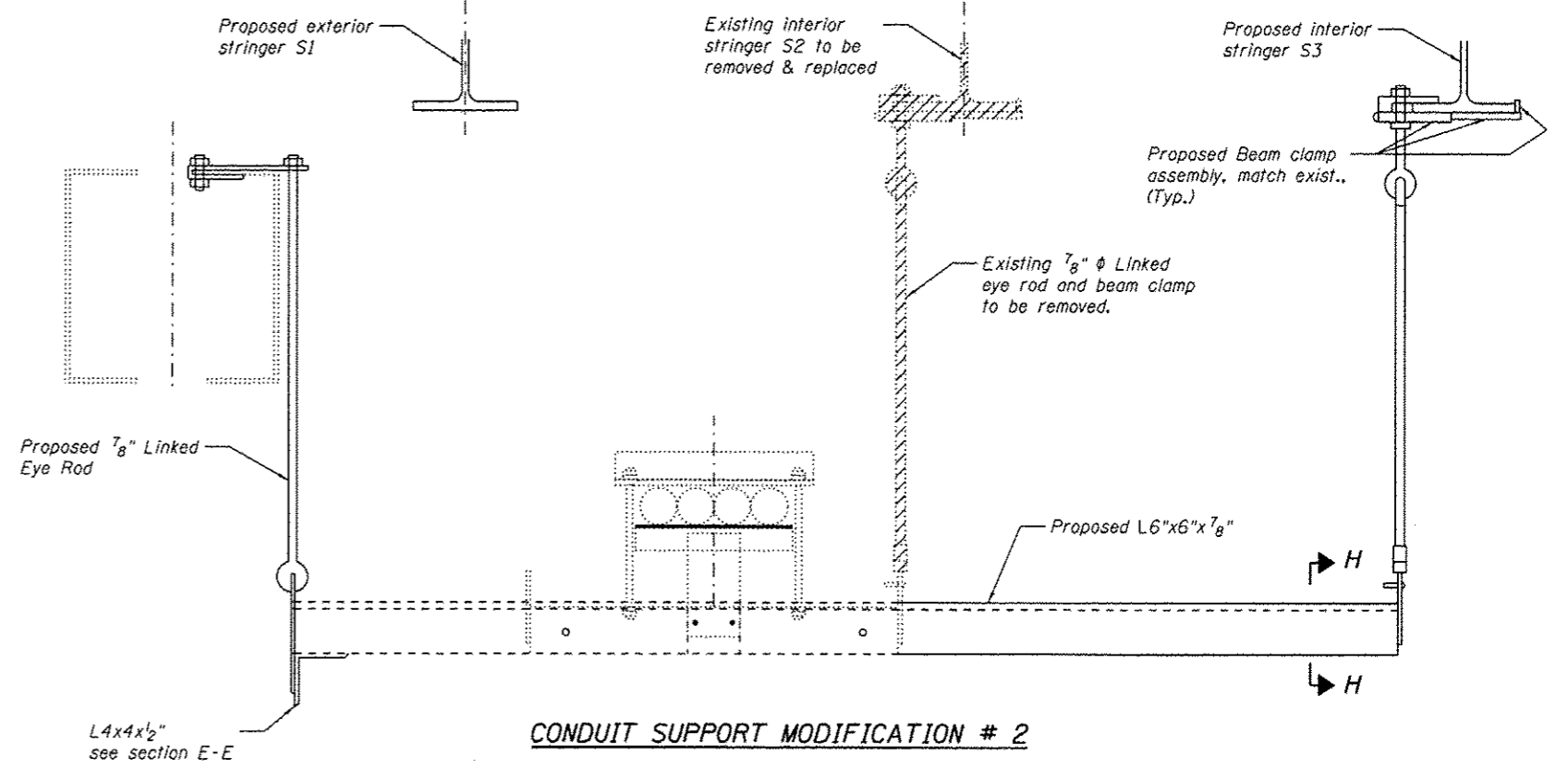

CONDUIT SUPPORT MODIFICATION # 2

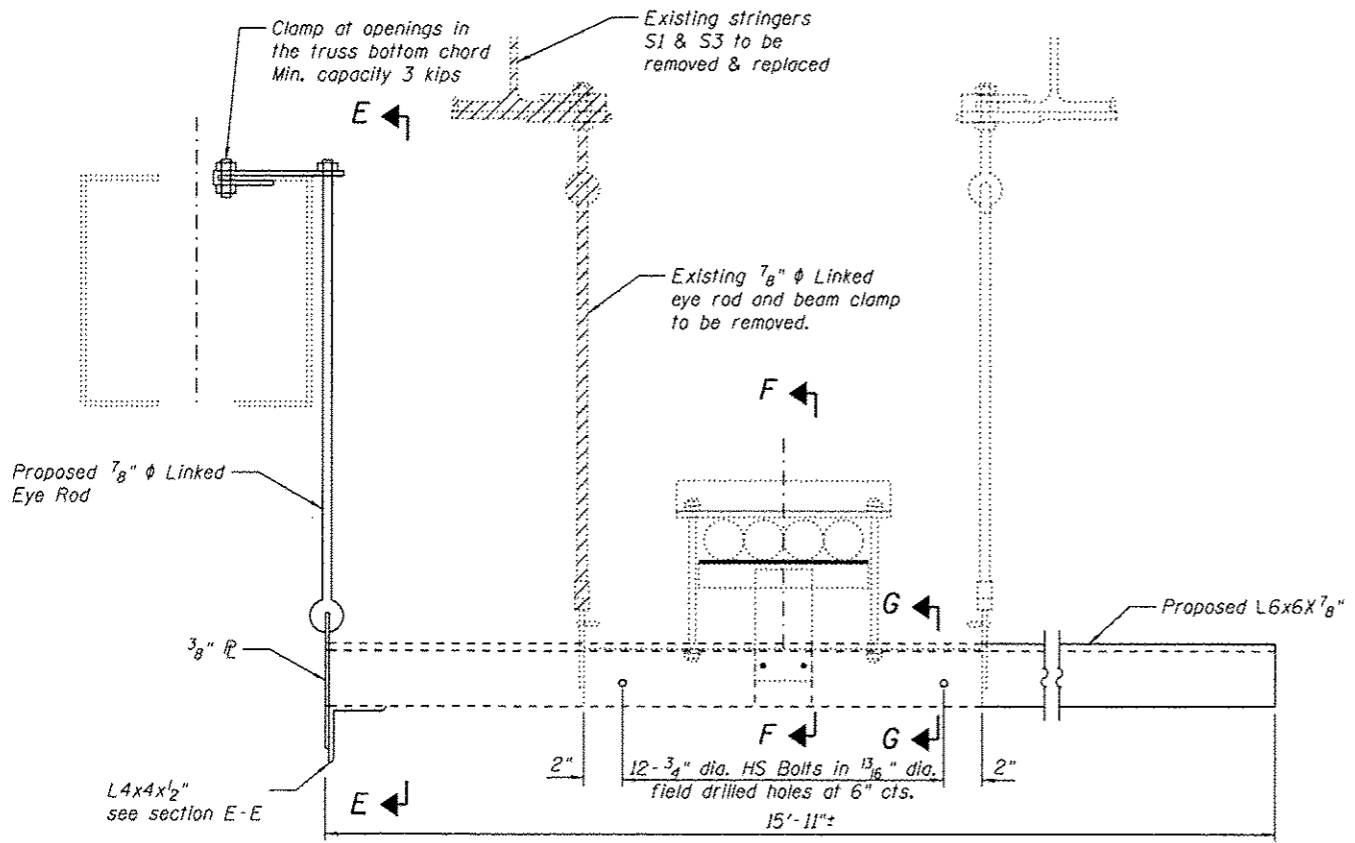

CONDUIT SUPPORT MODIFICATION # 1

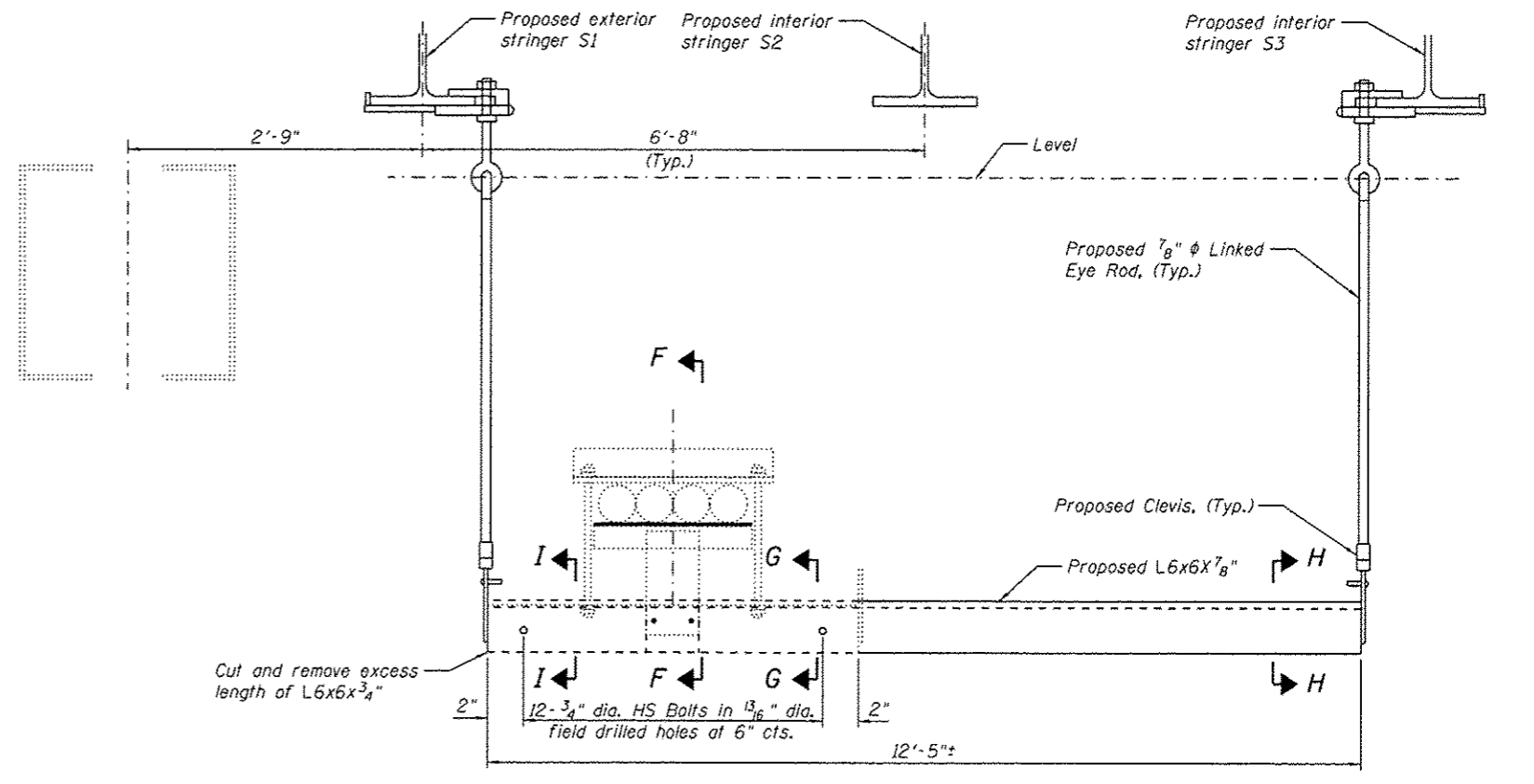

FINAL CONFIGURATION
 (Modified Hangers - H6 & H12)
 (Total 40 Locations, 4-H6 and 36-H12)

Notes:
 See sheet S027 of S138 for bill of material, cross sections, locations of hangers, notes and other details.

(Sheet 2 of 3)



USER NAME *	DESIGNED - JJA	REVISED -
FILE NAME *	CHECKED - TBP	REVISED -
PLOT SCALE *	DRAWN - AJF	REVISED -
PLOT DATE *	CHECKED - VPT	REVISED -

STATE OF ILLINOIS
DEPARTMENT OF TRANSPORTATION

MAIN SPANS CONDUIT HANGER MODIFICATION DETAILS
S.N. 082-6001 MLK BRIDGE OVER MISSISSIPPI RIVER

F.A.P. RTE.	SECTION	COUNTY	TOTAL SHEETS	SHEET NO.
799	1BR, DRS-2	ST. CLAIR	156	044
CONTRACT NO. 76B03				
ILLINOIS FED. AID PROJECT				

SHEET NO. S026 OF S138 SHEETS

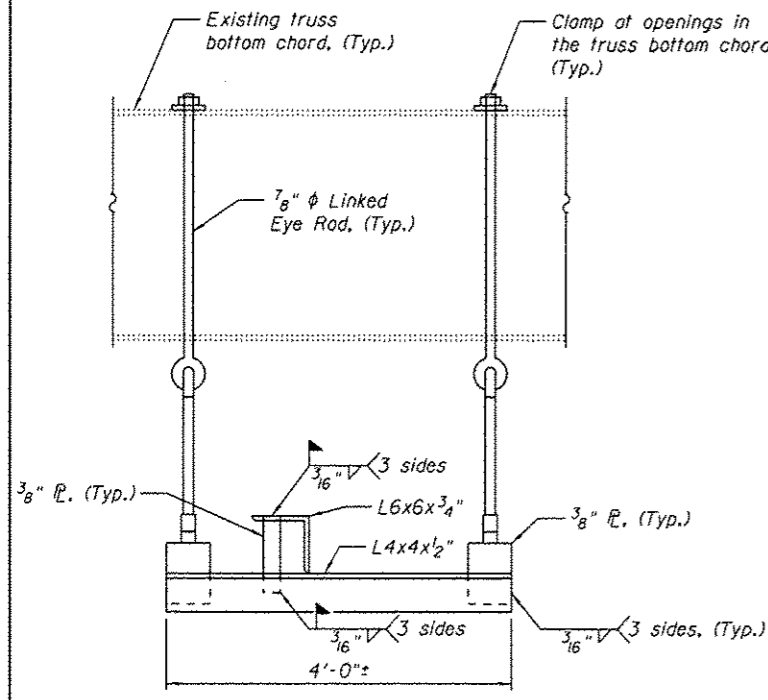

SECTION E-E

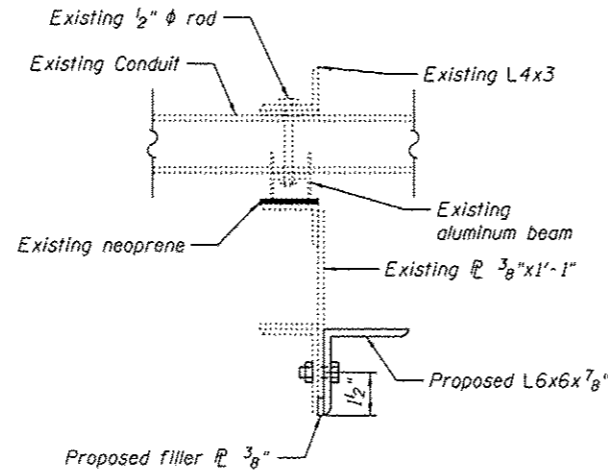

SECTION F-F
(cross section at H-6)

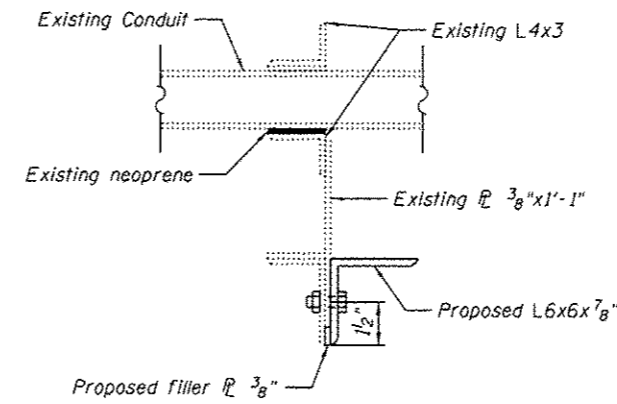

SECTION F-F
(cross section at H-12)

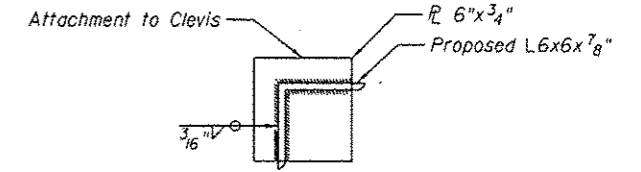

SECTION H-H

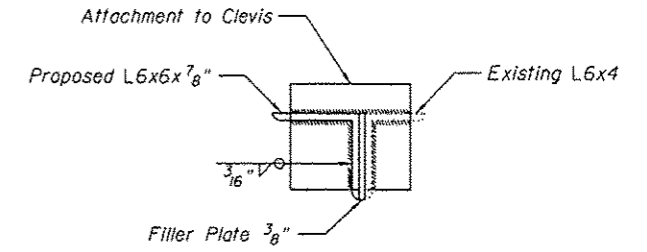

SECTION I-I

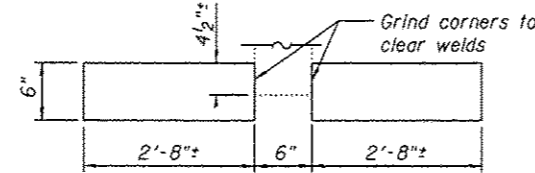

FILLER PLATES 3/8"

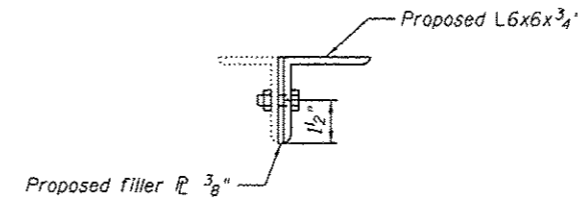

SECTION G-G

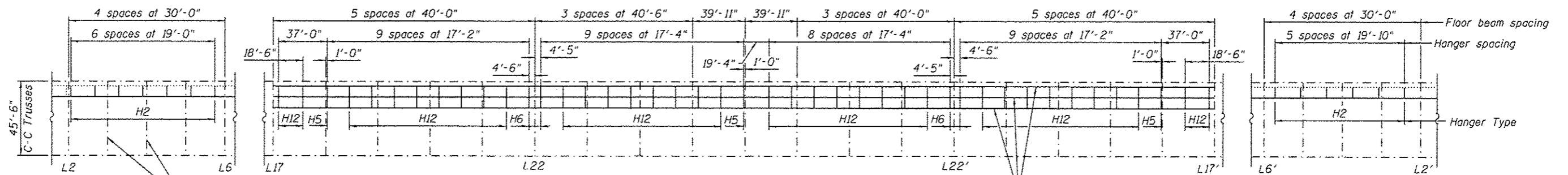

HANGER LOCATION PLAN

Notes:

The Contractor is to verify the existing dimensions prior to fabricating the support assembly. The existing details shown here are derived from the existing plans. It is intended to keep the utility conduit at the current elevation.

Hangers H5 are connected to floor beams and no change is expected to the support assembly.

All hanger assemblies required including angles, eye rods, end plates and fasteners are included in the price of Conduit Support System.

If Contractor chooses to use different configurations for temporary support than shown on sheets S025 thru S027, then plans showing revised configuration shall be submitted to Bridge Office for review.

See Sheet S061 of S138 for stringer repairs at L2 thru L6 and L2' thru L6'.

See Sheet S014 of S138 for stringer replacements between L17 and L17'.

MODIFICATION SEQUENCE FOR H6 & H12

1. Extend bottom support angle and hang from truss chord.
2. Remove attachment to exterior stringer S1.
3. Replace all existing stringers except interior stringer S2.
4. Attach to proposed stringers S1 and S3.
5. Replace interior stringer S2.

BILL OF MATERIAL

Item	Unit	Total
Conduit Support System	L Sum	1

(Sheet 3 of 3)

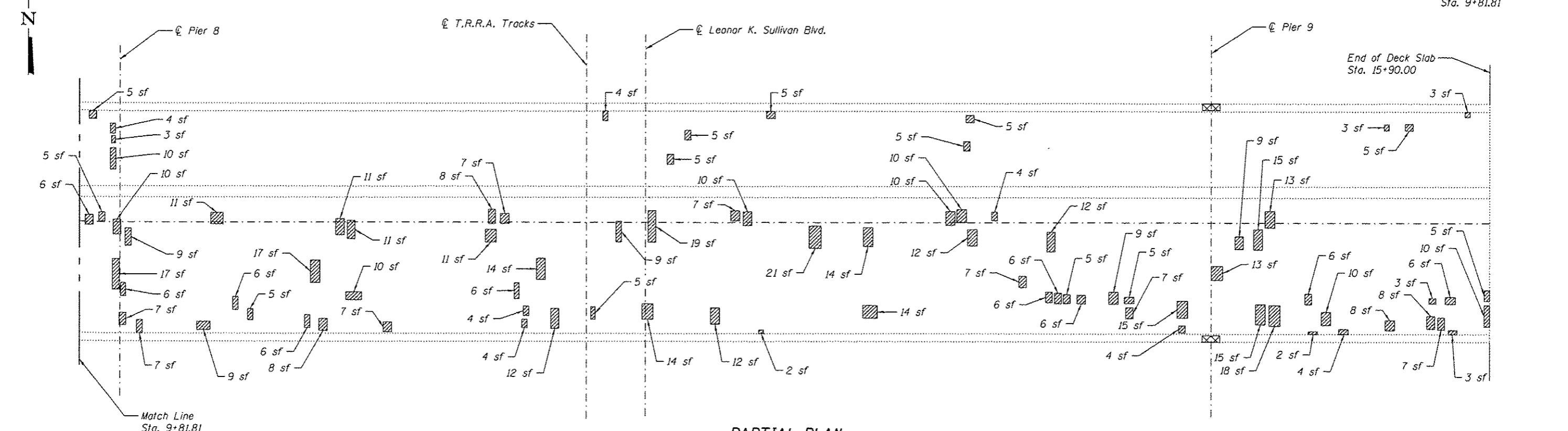
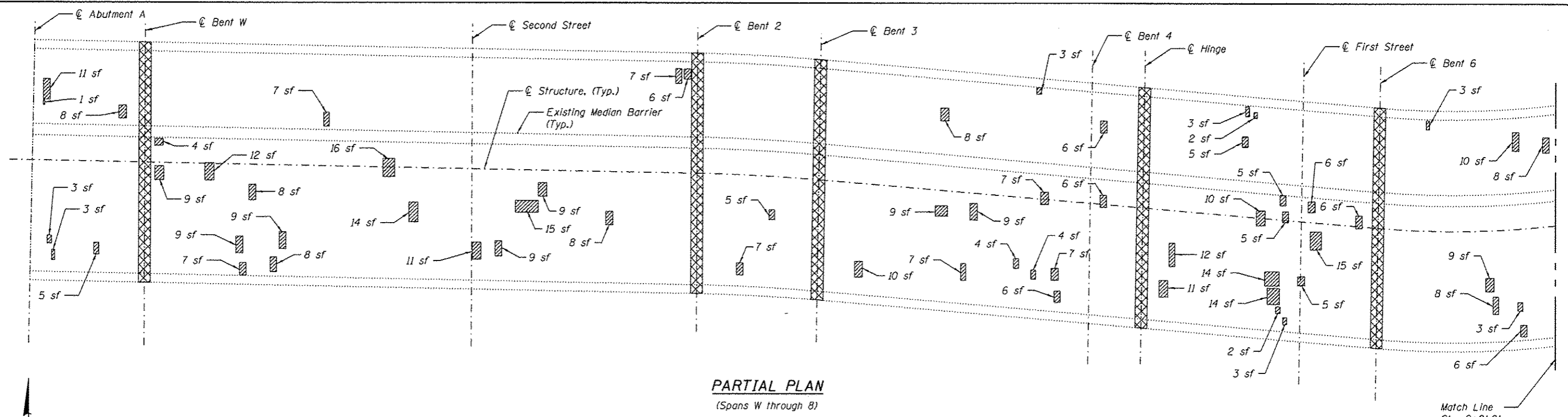

LEGEND

- sf Square Feet
- Deck Slab Repair (Partial)
- Concrete Removal

Notes:
 Repair of the existing deck slab shall include but may not be limited to the areas shown. The actual area to be repaired will be determined by the Engineer at the time of construction. See Sheet S092 of S138 for concrete removal quantities. Bridge deck concrete sealer shall be applied on top and inside surfaces of all concrete barriers and top of slab for entire bridge including grid deck floor system.

BILL OF MATERIAL

ITEM	UNIT	TOTAL
Deck Slab Repair (Partial)	Sq. Yd.	129
Bridge Deck Concrete Sealer	Sq. Ft.	55,653



USER NAME *
 FILE NAME *
 PLOT SCALE *
 PLOT DATE * 05/02/2014

DESIGNED - JJA
 CHECKED - TBP
 DRAWN - AJF
 CHECKED - VPT

REVISED -
 REVISED -
 REVISED -
 REVISED -

STATE OF ILLINOIS
DEPARTMENT OF TRANSPORTATION

CONCRETE DECK REPAIRS
S.N. 082-6001 MLK BRIDGE OVER MISSISSIPPI RIVER

F.A.P. RTE. 799	SECTION 1BR, DRS-2	COUNTY ST. CLAIR	TOTAL SHEETS 156	SHEET NO. 046
SHEET NO. S028 OF S138 SHEETS			CONTRACT NO. 76B03	
ILLINOIS FED. AID PROJECT				

Deck Slab Begins
Sta. 23+13.25

Match Line
Sta. 28+15.24

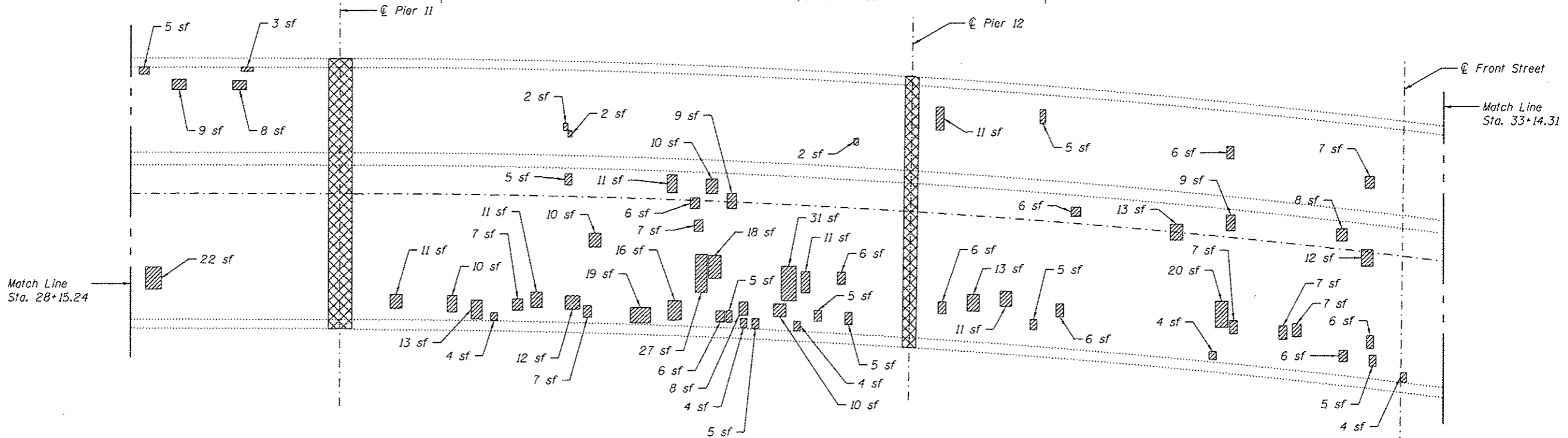
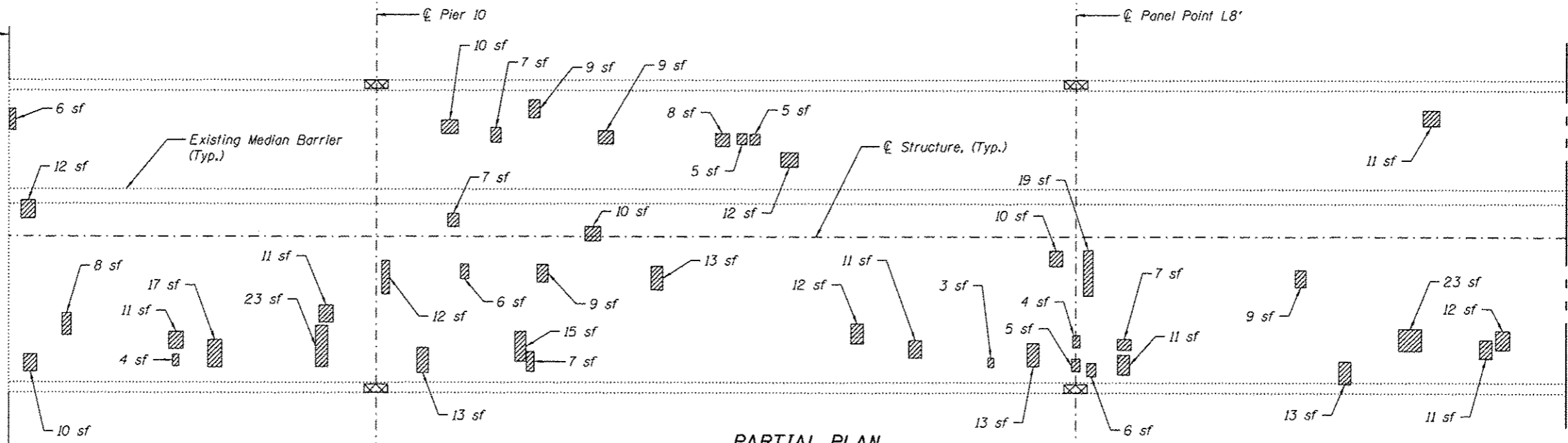

Match Line
Sta. 28+15.24

Match Line
Sta. 33+14.31

LEGEND

sf Square Feet

Deck Slab Repair (Partial)

Concrete Removal

Notes:

Repair of the existing deck slab shall include but may not be limited to the areas shown. The actual area to be repaired will be determined by the Engineer at the time of construction. See Sheet S092 of S138 for concrete removal quantities. Bridge deck concrete sealer shall be applied on top and inside surfaces of all concrete barriers and top of slab for entire bridge including grid deck floor system.

BILL OF MATERIAL

ITEM	UNIT	TOTAL
Deck Slab Repair (Partial)	Sq. Yd.	110
Bridge Deck Concrete Sealer	Sq. Ft.	85,886

(Sheet 2 of 3)



USER NAME *	DESIGNED - JJA	REVISED -
FILE NAME *	CHECKED - TBP	REVISED -
PLOT SCALE *	DRAWN - AJF	REVISED -
PLOT DATE *	CHECKED - VPT	REVISED -

**STATE OF ILLINOIS
DEPARTMENT OF TRANSPORTATION**

**CONCRETE DECK REPAIRS
S.N. 082-6001 MLK BRIDGE OVER MISSISSIPPI RIVER**

SHEET NO. S029 OF S138 SHEETS

F.A.P. RTE.	SECTION	COUNTY	TOTAL SHEETS	SHEET NO.
799	1BR, ORS-2	ST. CLAIR	156	047
			CONTRACT NO. 76B03	
ILLINOIS FED. AID PROJECT				

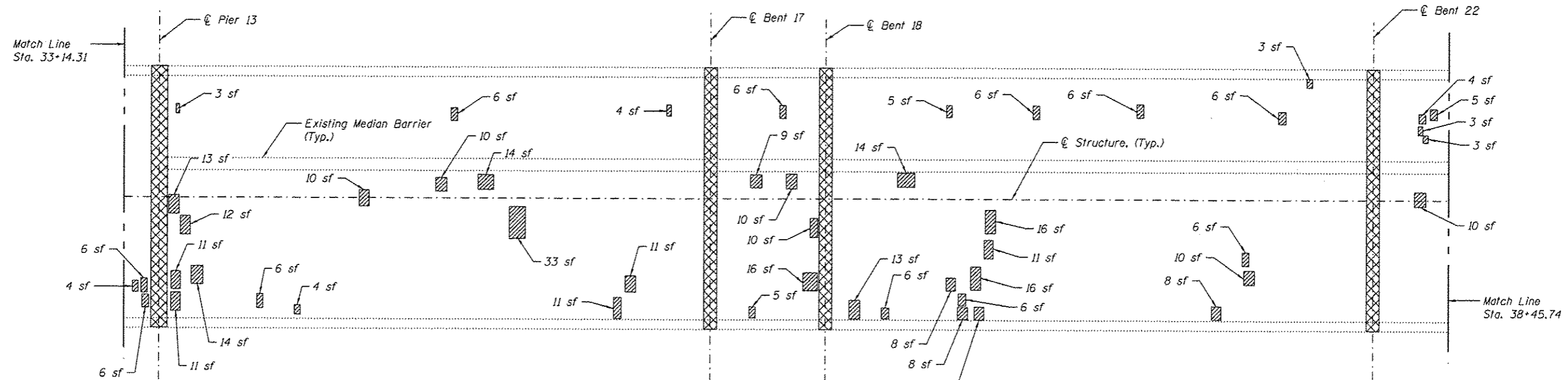

PARTIAL PLAN
(Spans 14 through 23)

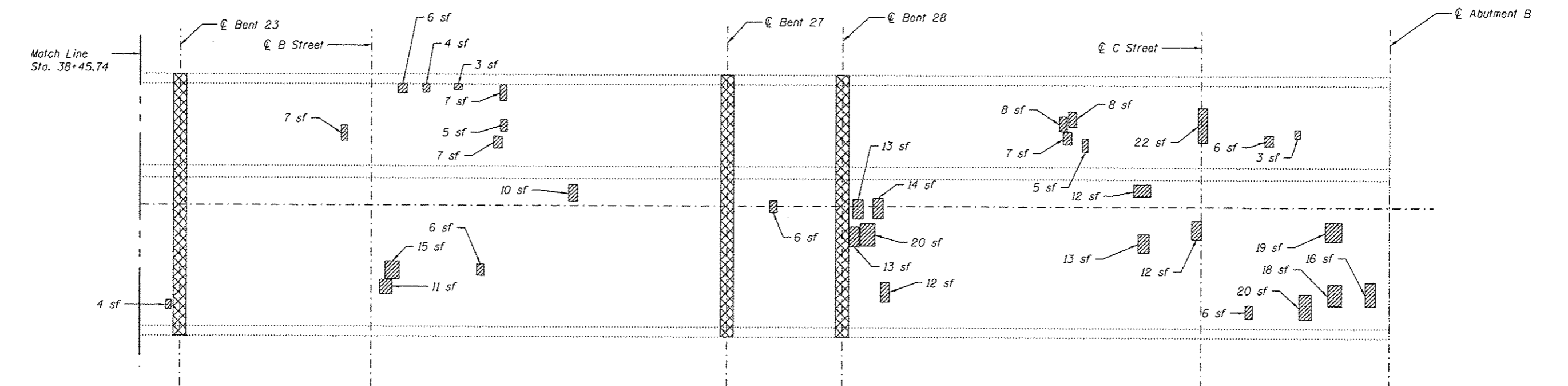

PARTIAL PLAN
(Spans 24 through 32)

LEGEND

sf Square Feet

Deck Slab Repair (Partial)

Concrete Removal

Notes:
 Repair of the existing deck slab shall include but may not be limited to the areas shown. The actual area to be repaired will be determined by the Engineer at the time of construction. See Sheet S092 of S138 for concrete removal quantities. Bridge deck concrete sealer shall be applied on top and inside surfaces of all concrete barriers and top of slab for entire bridge including grid deck floor system.

BILL OF MATERIAL

ITEM	UNIT	TOTAL
Deck Slab Repair (Partial)	Sq. Yd.	85
Bridge Deck Concrete Sealer	Sq. Ft.	51,900

(Sheet 3 of 3)

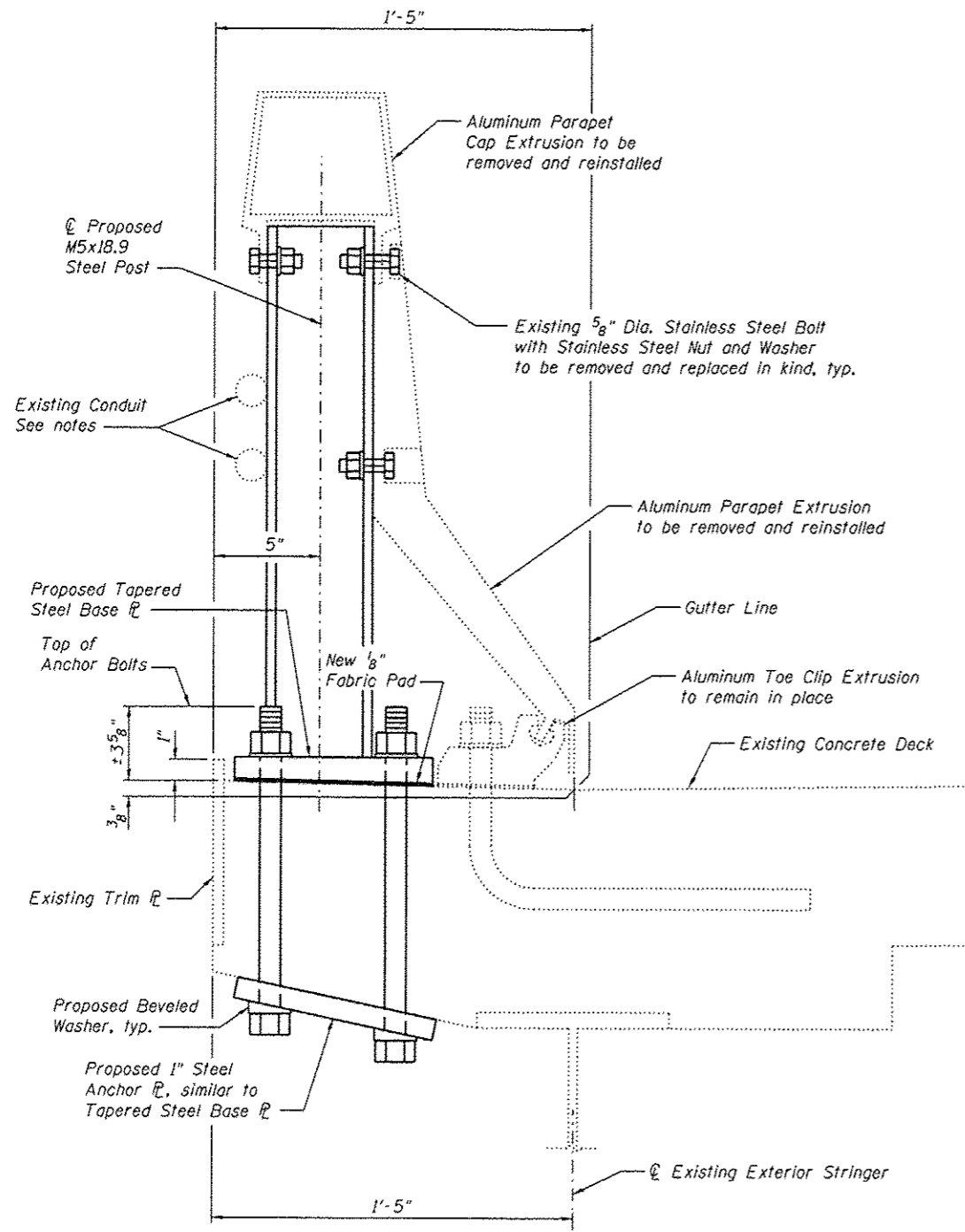

**TYPICAL SECTION THRU PARAPET
AT CONCRETE DECK
SPANS 9, 10 AND 11**

BILL OF MATERIAL

Item	Unit	Total
Steel Post, Attached to Structures	Each	504
Remove and Reinstall Existing Aluminum Parapet	Foot	1180

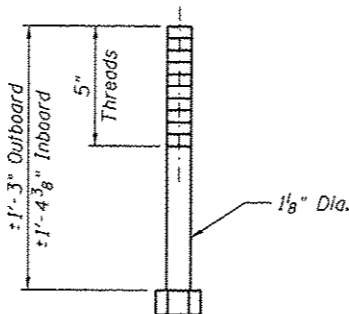

**TYPICAL PROPOSED
ANCHOR BOLT DETAIL**

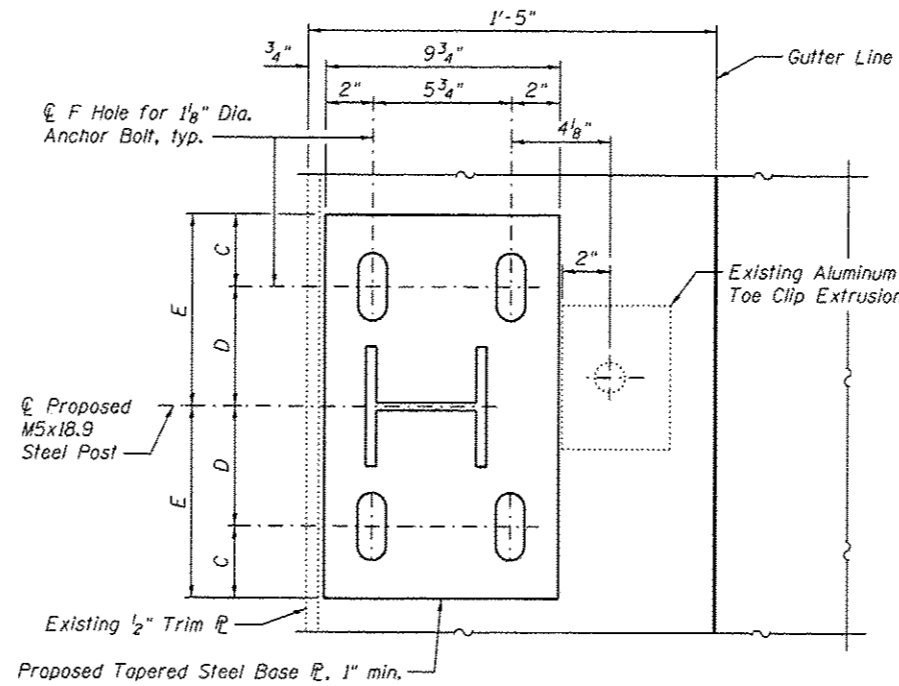

PARAPET ANCHORAGE PLAN

LOCATION	DIMENSIONS						
	A	B	C	D	E	F (Base R)	F (Anchor R)
L6 and L6'	1'-4"	1'-0"	2"	6"	8"	1 3/16" Dia.	1 7/16" Dia.
Otherwise	1'-8"	1'-2"	3"	7"	10"	1 3/16" x 2 13/16" Slotted	1 7/16" Dia.

Notes:
Anchorage plan at L6 and L6' differs from typical due to anchorage proximity to floorbeam.
Anchor plate is not tapered.

Parapet Post Replacement Procedure at Concrete Deck

- Remove fasteners from existing aluminum parapet extrusion and slide extrusion either left or right to facilitate existing post removal.
- Cut existing 1" anchor bolts flush with the existing concrete surface, grind smooth, and seal with epoxy. Cost is included with Remove and Reinstall Existing Aluminum Parapet.
- Layout posts with the following constraints:
 - maximum post spacing = 6'-0"
 - four posts spaced no more than 2'-11" from centerline shall be placed at each end panel posts shall be placed so as to not interfere with floorbeams
 - posts shall be placed with the existing aluminum extrusion attachments in mind and so that the need for additional holes being drilled in the aluminum extrusion is kept to a minimum.
- Install new parapet post with new anchor bolts. Drill new holes in aluminum extrusion using new post as a template when required.
- Re-install existing aluminum parapet extrusion and fasten to new post with new fasteners.

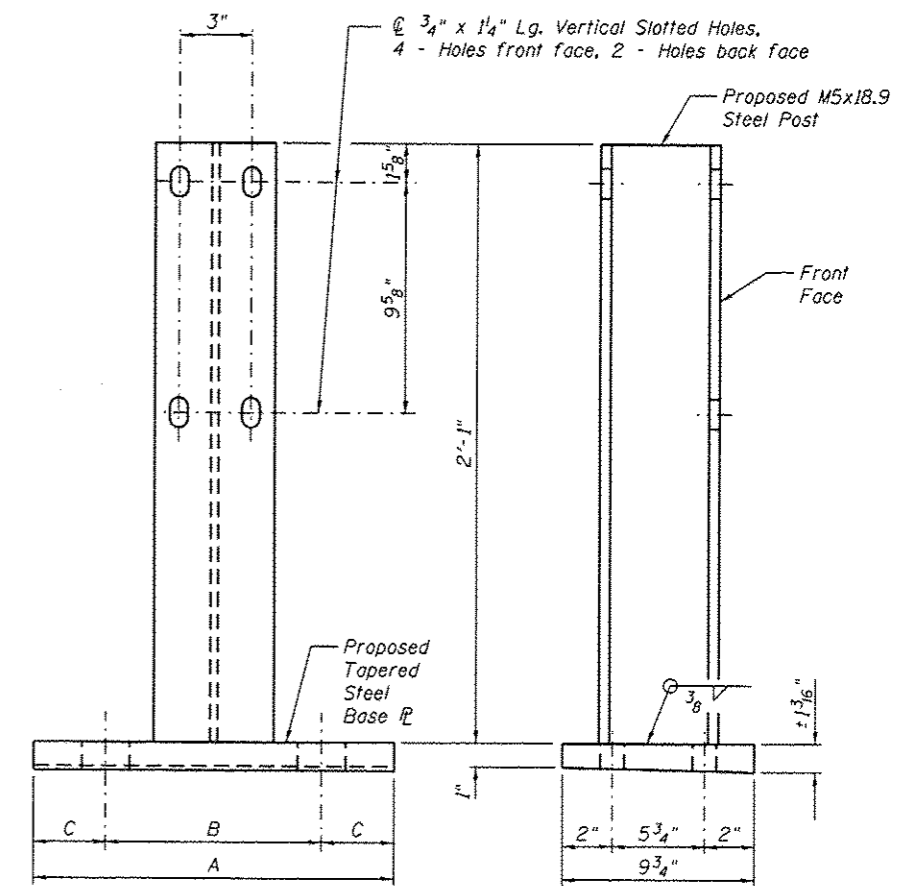

PROPOSED STEEL POST

Notes:
The contractor shall exercise extreme care during removal of existing parapet.
See existing parapet erection plans for additional details.
Field drill additional holes in the aluminum parapet extrusion as required. An estimated 848 additional holes are required.
Abandoned holes in aluminum extrusion shall be filled with a 5/8" dia. Stainless Steel bolt. An estimated 384 bolts are required.
All steel shapes and plates shall conform to the requirements of AASHTO M 270 Gr. 36.
Post and parapet shall be in accordance with Section 509 of the Standard Specifications, except as noted and shall be paid for at the contract unit price Each for Steel Post, Attached to Structures.
All stainless steel hardware for railings shall conform to Section 1006.31 of the Standard Specifications.
All post and anchor devices shall be galvanized after shop fabrication in accordance with AASHTO M 111.
Anchor bolt material shall conform to the requirements of ASTM F 1554 Gr. 36 and Section 1006.09 of the Standard Specifications.
Structural plate washers or a continuous bar with standard holes, not less than 0.3125 in. in thickness shall be required to completely cover long slotted holes in the anchorage. Hardened washers shall be placed over the outer surface of the plate washer or bar.
Nut and washer material for anchor bolts shall conform to Section 1006.09 of the Standard Specifications, except as noted.
Anchor bolts, washers and nuts shall be galvanized in accordance with AASHTO M 232, Class C.
Existing conduit shall be temporarily supported while posts are being replaced and reattached when posts are in place.
The cost of posts, base plates, anchor plates, bolts, nuts, washers, fabric pads, and anchor bolts along with complete installation shall be included in the cost of Steel Post, Attached to Structure.
The cost of drilling new holes in the aluminum parapet extrusion and the cost to temporarily support and reattach existing conduit shall be included in the cost of Remove and Reinstall Existing Aluminum Parapet.

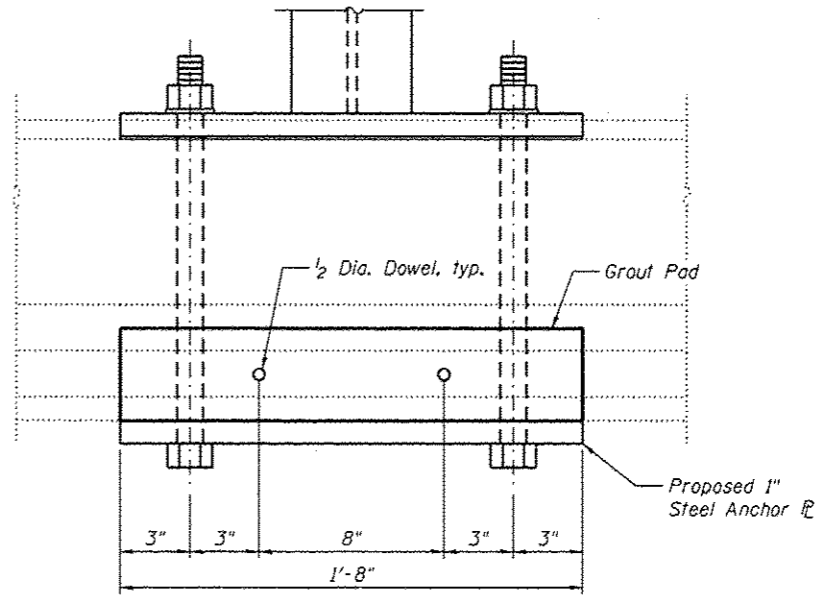
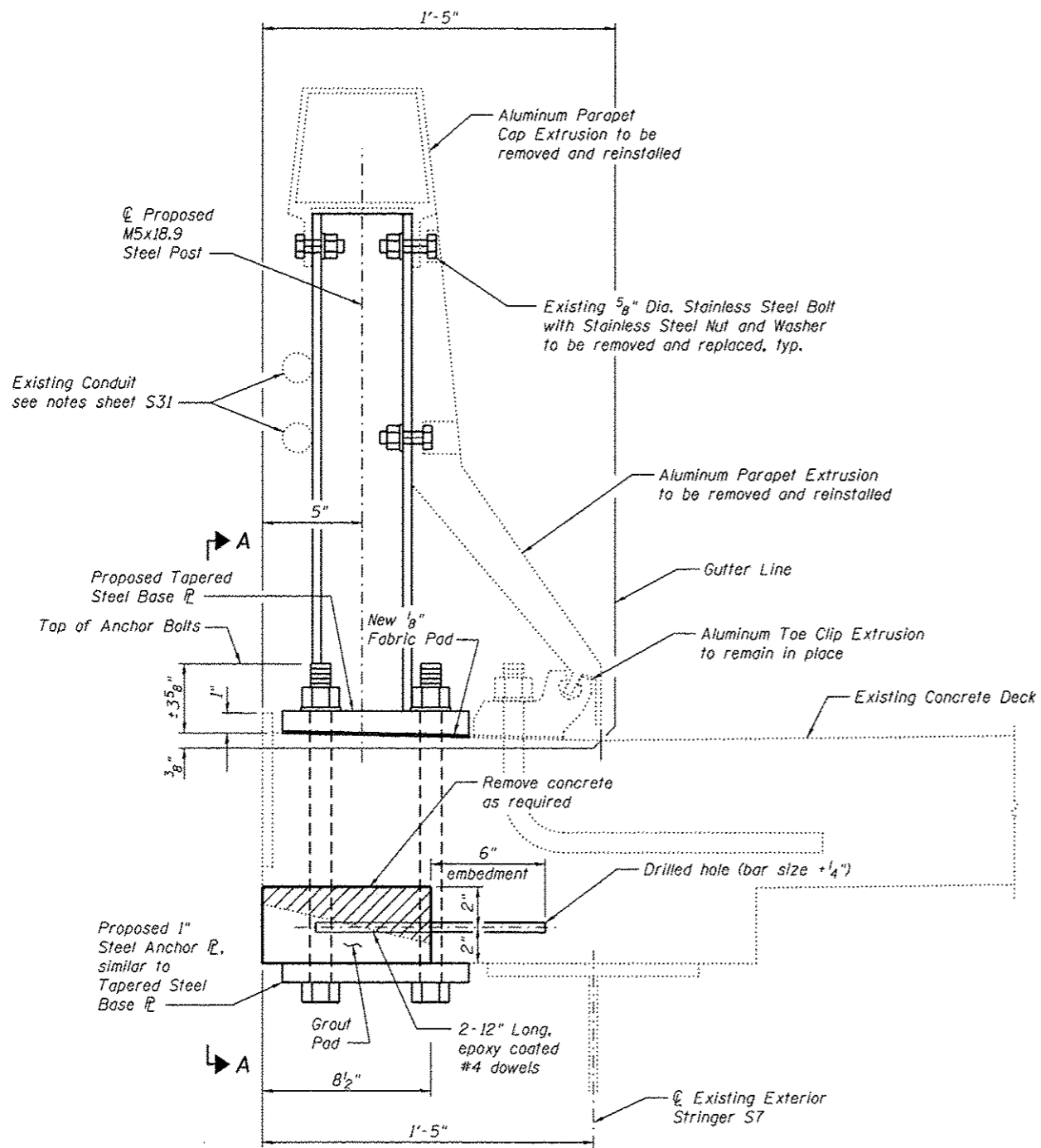

VIEW A-A

From Sta. 9+99.75 to Sta. 10+75.79
**PART SECTION THRU PARAPET
 FOR PANEL POINTS 0 THRU 3**

Notes:
 See existing parapet erection plans and sheet S31 for additional details.
 Drilled and set dowel bars shall be installed according to Article 584 of the Standard Specifications.
 Non shrink grout according to Article 1024 of the Standard Specifications shall be used for the grout pad.
 Dowel bars shall be threaded and the material shall conform to the requirements of ASTM A307.
 The cost of grout pad, dowel bars, chemical adhesive and installation shall be included in the cost of Steel Post, Attached to Structure.



USER NAME *	DESIGNED - ZJB	REVISED
	CHECKED - YSS	REVISED
PLOT SCALE *	DRAWN - PRC	REVISED
PLOT DATE * 05/02/2014	CHECKED - ZJB	REVISED

STATE OF ILLINOIS
 DEPARTMENT OF TRANSPORTATION

MAIN SPANS ALUMINUM PARAPET DETAILS - CONCRETE DECK-2
 S.N. 082-6001 MLK BRIDGE OVER MISSISSIPPI RIVER

F.A.P. RTE.	SECTION	COUNTY	TOTAL SHEETS	SHEET NO.
799	1BR, ORS-2	ST. CLAIR	156	50
			CONTRACT NO. 76B03	
ILLINOIS FED. AID PROJECT				

SHEET NO. 532 OF 5138 SHEETS

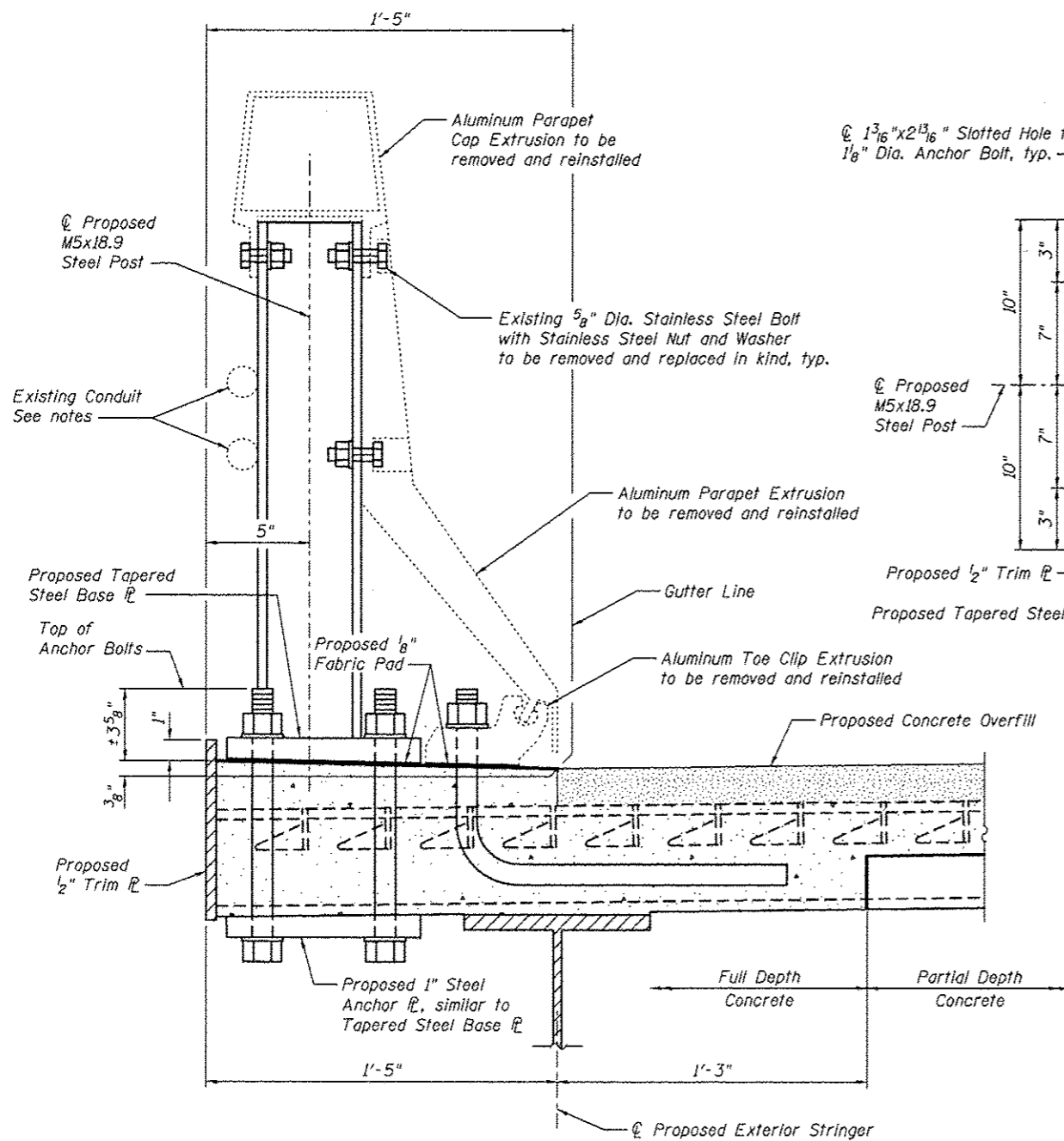

**SECTION THRU PARAPET
AT GRID DECK FLOOR SYSTEM SPAN 10**

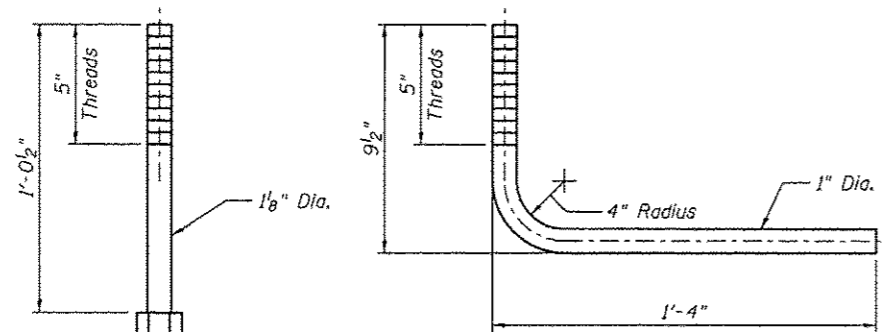

PROPOSED ANCHOR BOLT DETAILS

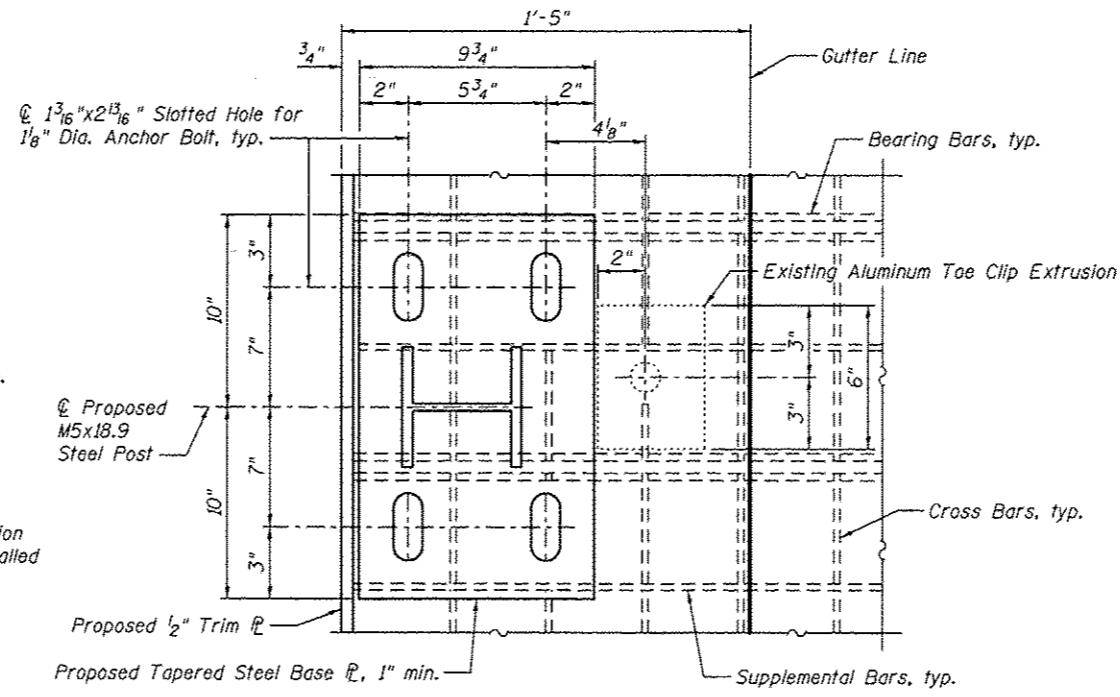

Note:
Cut grid deck cross and supplemental bars as required for placing anchor bolts. Do not cut bearing bars.

PARAPET ANCHORAGE PLAN

- Parapet Post Replacement Procedure at Grid Deck*
- Remove fasteners from existing aluminum parapet extrusion and completely remove during grid deck replacement. Match mark parts for re-installation.
 - Toe clip anchor bolts shall be placed with grid deck. After grid deck concrete has been placed and cured layout posts with the following constraints:
 - maximum post spacing = 6'-0"
 - four posts spaced no more than 2'-11" from centerline shall be placed at each end panel
 - posts shall be placed so as to not interfere with floorbeams
 - posts shall be placed with the existing aluminum extrusion attachments in mind and so that the need for additional holes being drilled in the aluminum extrusion is kept to a minimum.
 - Install new parapet post with new anchor bolts. Drill new holes in aluminum extrusion using new post as a template when required.
 - Re-install existing toe clip and existing aluminum parapet extrusion. Fasten aluminum parapet extrusion to new post with new fasteners.

BILL OF MATERIAL

Item	Unit	Total
Steel Post, Attached to Structures	Each	308
Remove and Reinstall Existing Aluminum Parapet	Foot	725

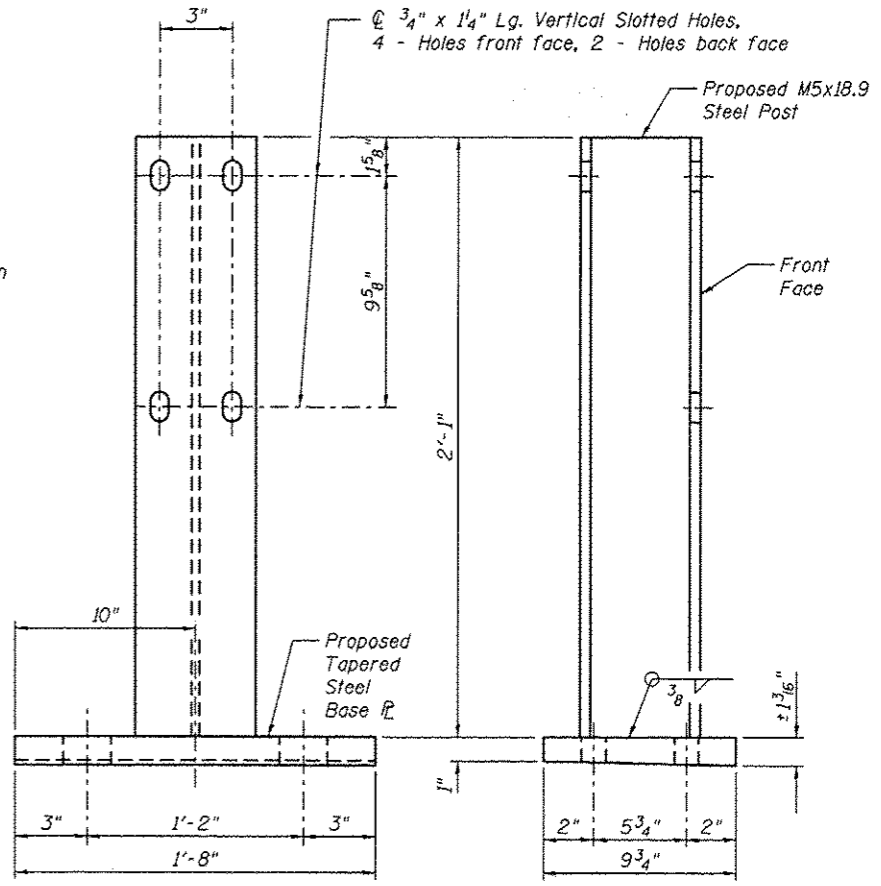

PROPOSED STEEL POST

Notes:
The contractor shall exercise extreme care during removal of existing parapet.
See existing parapet erection plans for additional details.
Field drill additional holes in the aluminum parapet extrusion as required. An estimated 388 additional holes are required.
Abandoned holes in aluminum extrusion shall be filled with a 5/8" dia. Stainless Steel bolt. An estimated 102 bolts are required.
All steel shapes and plates shall conform to the requirements of AASHTO M 270 Gr. 36.
Post and parapet shall be in accordance with Section 509 of the Standard Specifications, except as noted and shall be paid for at the contract unit price each for Steel Post, Attached to Structures.
All stainless steel hardware for railings shall conform to Section 1006.31 of the Standard Specifications.
All post and anchor devices shall be galvanized after shop fabrication in accordance with AASHTO M 111.
Anchor bolt material shall conform to the requirements of ASTM F 1554 Gr. 36 and Section 1006.09 of the Standard Specifications.
Structural plate washers or a continuous bar with Standard holes, not less than 0.3125 in. in thickness, shall be required to completely cover long slotted holes. Hardened washers shall be placed over the outer surface of the plate washer or bar.
Nut and washer material for anchor bolts shall conform to Section 1006.09 of the Standard Specifications, except as noted.
Anchor bolts, washers and nuts shall be galvanized in accordance with AASHTO M232, Class C.
Existing conduit shall be temporarily supported while posts are being replaced and reattached when posts are in place.
The cost of posts, base plates, anchor plates, bolts, nuts, washers, fabric pads, and anchor bolts along with complete installation shall be included in the cost of Steel Post, Attached to Structure.
The cost of drilling new holes in the aluminum parapet extrusion and the cost to temporarily support and reattach existing conduit shall be included in the cost of Remove and Reinstall Existing Aluminum Parapet.



USER NAME *	DESIGNED - ZJB	REVISED
	CHECKED - YSS	REVISED
PLOT SCALE *	DRAWN - PRC	REVISED
PLOT DATE 03/20/2014	CHECKED - ZJB	REVISED

STATE OF ILLINOIS
DEPARTMENT OF TRANSPORTATION

MAIN SPANS ALUMINUM PARAPET DETAILS - GRID DECK
S.N. 082-6001 MLK BRIDGE OVER MISSISSIPPI RIVER

F.A.P. RTE. 799	SECTION 1BR, DRS-2	COUNTY ST. CLAIR	TOTAL SHEETS 156	SHEET NO. 51
CONTRACT NO. 76B03			ILLINOIS FED. AID PROJECT	

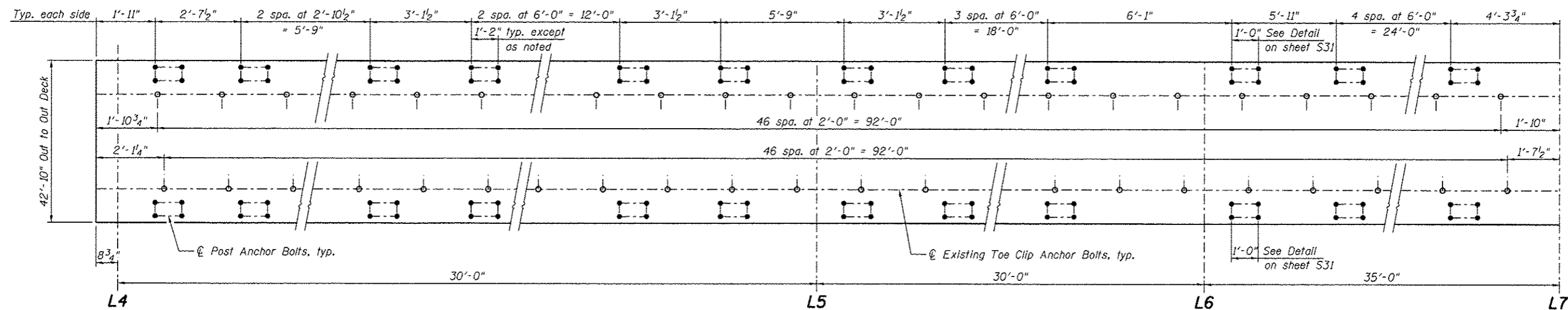
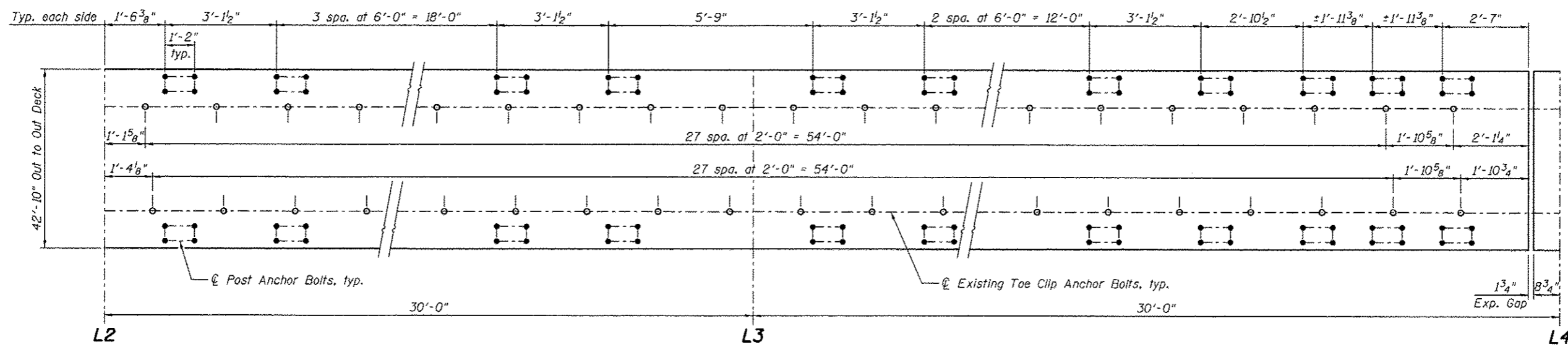
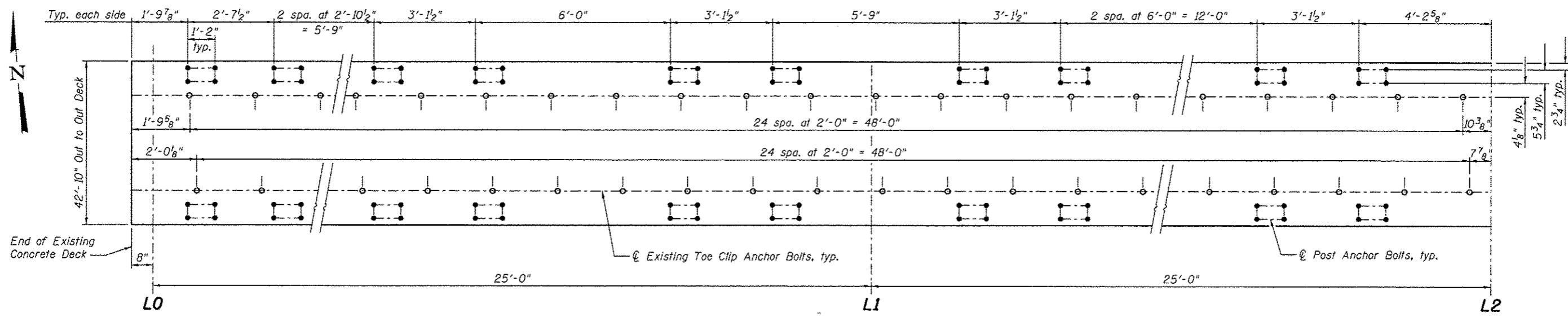

**ALUMINUM PARAPET POST ANCHOR BOLT LAYOUT
SPAN 9 - PANEL POINT L0 TO L7**

Notes:
Layout is suggested. For list of layout constraints see Parapet Post Replacement Procedure at Concrete Deck on sheet S31.
Existing toe clip anchor bolts to remain in place. Spacing shown for information only.
For Parapet Anchorage, see sheets S31 and S32.



USER NAME =	DESIGNED - ZJB	REVISED
PLLOT SCALE =	CHECKED - YSS	REVISED
PLLOT DATE = 03/20/2014	DRAWN - PRC	REVISED
	CHECKED - ZJB	REVISED

**STATE OF ILLINOIS
DEPARTMENT OF TRANSPORTATION**

**MAIN SPANS ALUMINUM PARAPET DETAILS - CONCRETE DECK L0-L7
S.N. 082-6001 MLK BRIDGE OVER MISSISSIPPI RIVER**

F.A.P. RTE. 799	SECTION IBR, DRS-2	COUNTY ST. CLAIR	TOTAL SHEETS 156	SHEET NO. 52
SHEET NO. S34 OF S138 SHEETS			CONTRACT NO. 76B03	
ILLINOIS FED. AID PROJECT				

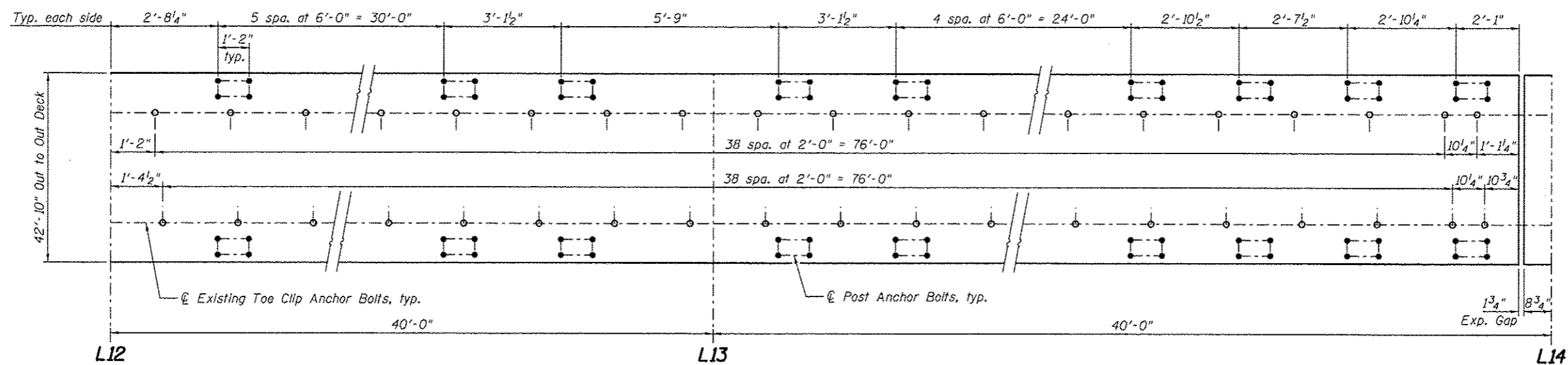
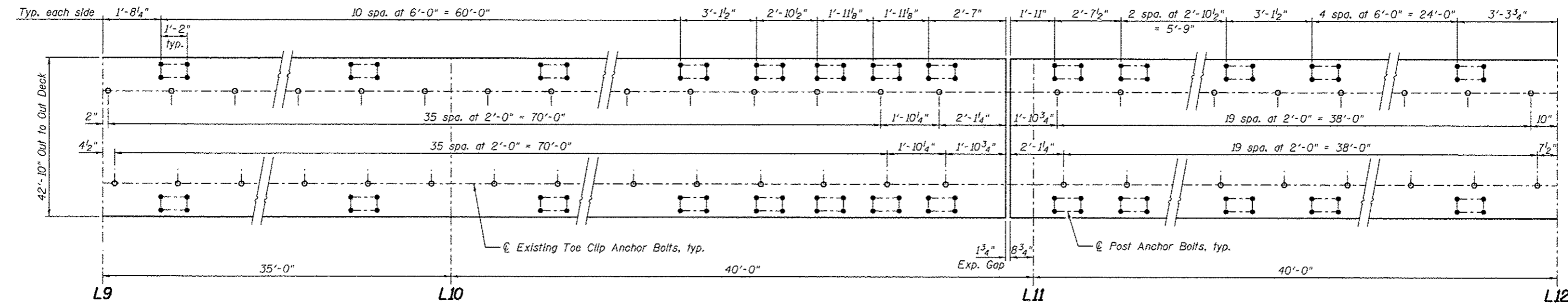
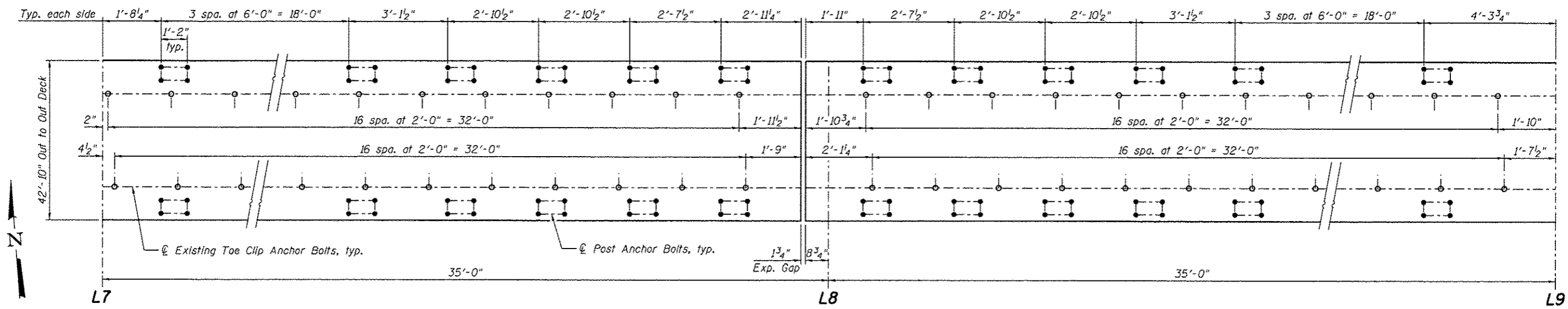

**ALUMINUM PARAPET POST ANCHOR BOLT LAYOUT
SPAN 9 - PANEL POINT L7 TO L14**

Notes:
Layout is suggested. For list of layout constraints see Parapet Post Replacement Procedure at Concrete Deck on sheet S31.
Existing toe clip anchor bolts to remain in place. Spacing shown for information only.
For Parapet Anchorage, see sheet S31.



USER NAME =	DESIGNED - ZJB	REVISED
PLOT SCALE =	CHECKED - YSS	REVISED
PLOT DATE = 8/3/2014	DRAWN - PRC	REVISED
	CHECKED - ZJB	REVISED

**STATE OF ILLINOIS
DEPARTMENT OF TRANSPORTATION**

**MAIN SPANS ALUMINUM PARAPET DETAILS - CONCRETE DECK L7-L14
S.N. 082-6001 MLK BRIDGE OVER MISSISSIPPI RIVER**

F.A.P. RTE. 799	SECTION 1BR, ORS-2	COUNTY ST. CLAIR	TOTAL SHEETS 156	SHEET NO. 53
SHEET NO. S35 OF S138 SHEETS			CONTRACT NO. 76B03	
ILLINOIS FED. AID PROJECT				

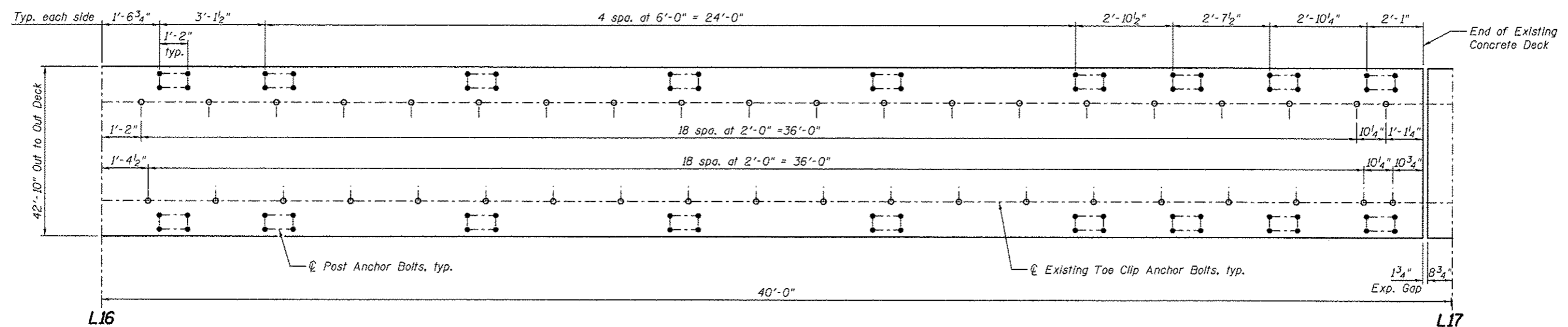
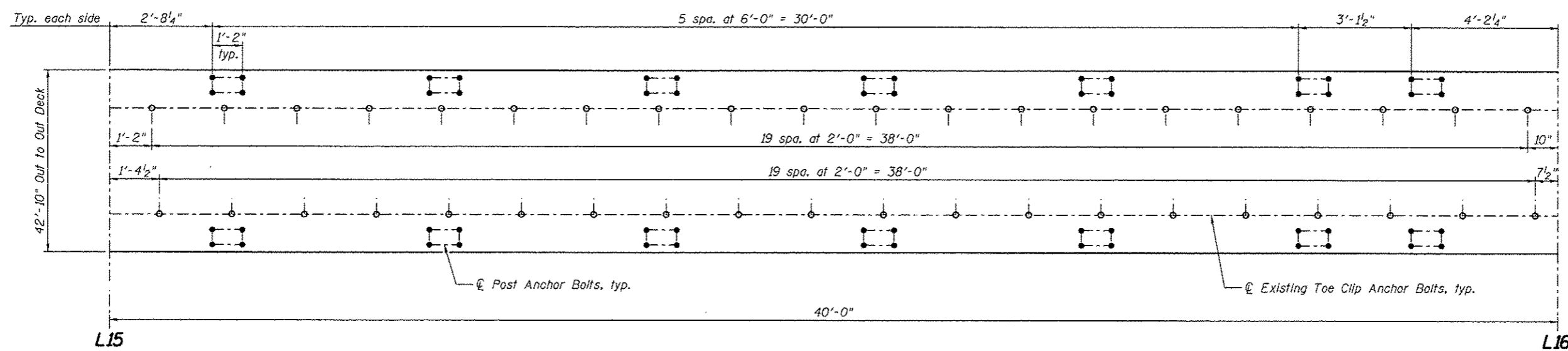
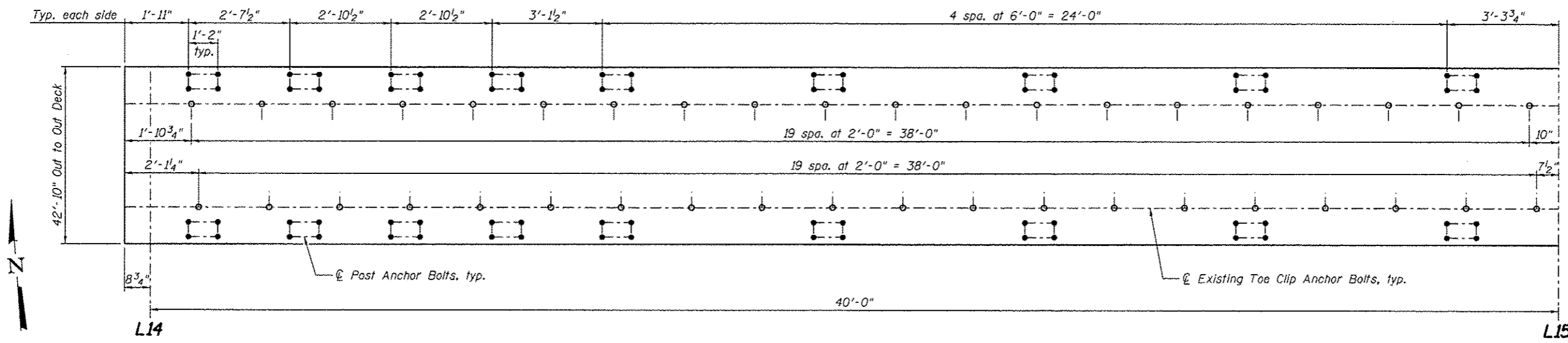

**ALUMINUM PARAPET POST ANCHOR BOLT LAYOUT
SPAN 10 - PANEL POINT L14 TO L17**

Notes:
 Layout is suggested. For list of layout constraints see Parapet Post Replacement Procedure of Concrete Deck on sheet S31.
 Existing toe clip anchor bolts to remain in place. Spacing shown for information only.
 For Parapet Anchorage, see sheet S31.



USER NAME =	DESIGNED - ZJB	REVISED
PLOT SCALE =	CHECKED - YSS	REVISED
PLOT DATE = 03/20/2014	DRAWN - PRC	REVISED
	CHECKED - ZJB	REVISED

**STATE OF ILLINOIS
DEPARTMENT OF TRANSPORTATION**

**MAIN SPANS ALUMINUM PARAPET DETAILS - CONCRETE DECK L14-L17
S.N. 082-6001 MLK BRIDGE OVER MISSISSIPPI RIVER**

F.A.P. RTE. 799	SECTION 1BR, DRS-2	COUNTY ST. CLAIR	TOTAL SHEETS 156	SHEET NO. 54
ILLINOIS FED. AID PROJECT			CONTRACT NO. 76B03	

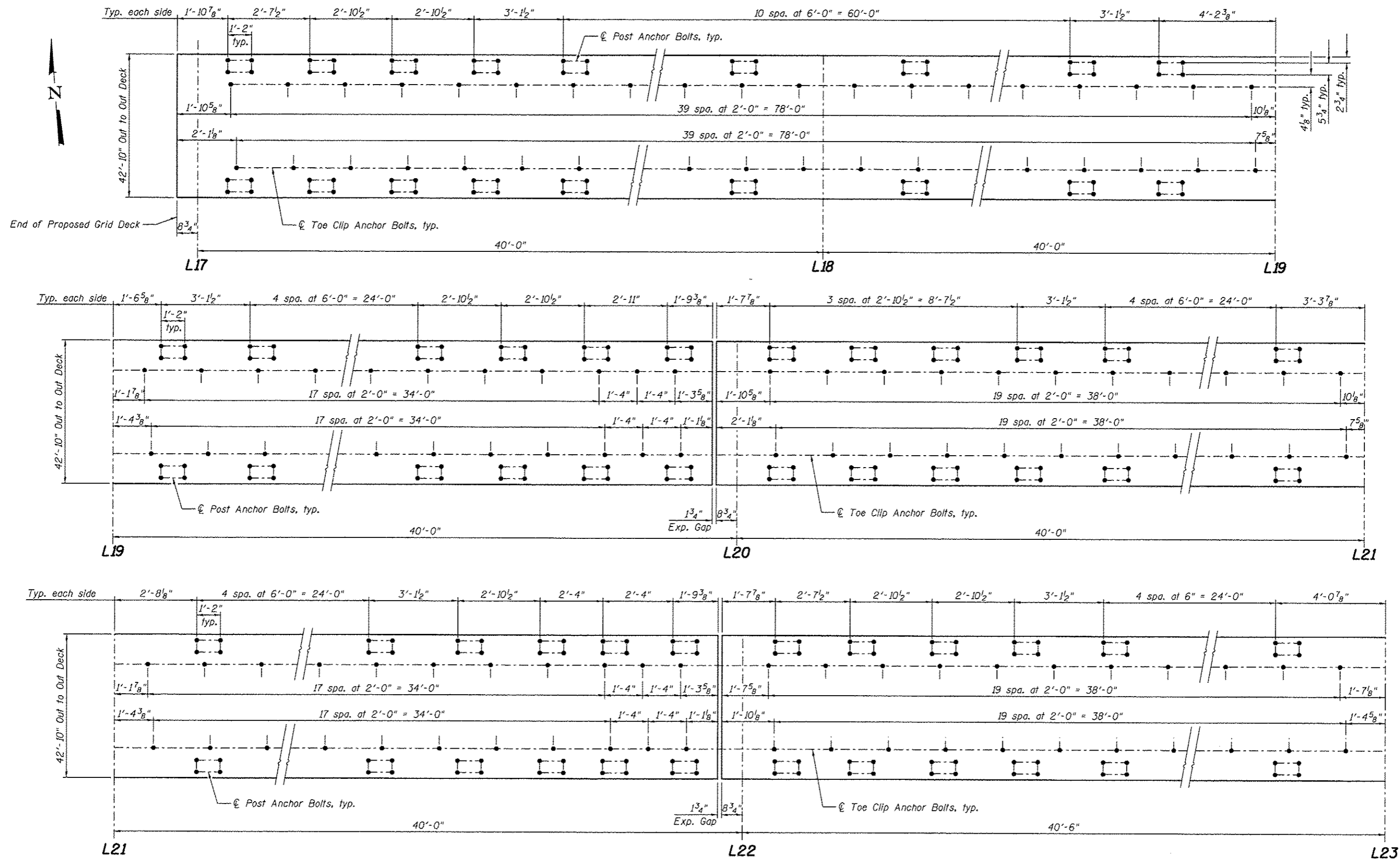

**ALUMINUM PARAPET POST AND TOE CLIP ANCHOR BOLT LAYOUT
SPAN 10 - PANEL POINT L17 TO L23**

Notes:
 Layout is suggested. For list of layout constraints see Parapet Post Replacement Procedure at Grid Deck on sheet S33.
 For Grid Deck Details, see sheets S14 to S16.
 For Parapet Anchorage, see sheet S33.
 Toe clip anchor bolt layout shall match existing.



USER NAME =	DESIGNED - ZJB	REVISED
PLOT SCALE =	CHECKED - YSS	REVISED
PLOT DATE = 03/20/2014	DRAWN - PRC	REVISED
	CHECKED - ZJB	REVISED

**STATE OF ILLINOIS
DEPARTMENT OF TRANSPORTATION**

**MAIN SPANS ALUMINUM PARAPET DETAILS - GRID DECK L17-L23
S.N. 082-6001 MLK BRIDGE OVER MISSISSIPPI RIVER**

F.A.P. RTE. 799	SECTION 1BR, DRS-2	COUNTY ST. CLAIR	TOTAL SHEETS 156	SHEET NO. 55
SHEET NO. S37 OF 513B SHEETS			CONTRACT NO. 76B03	
ILLINOIS FED. AID PROJECT				

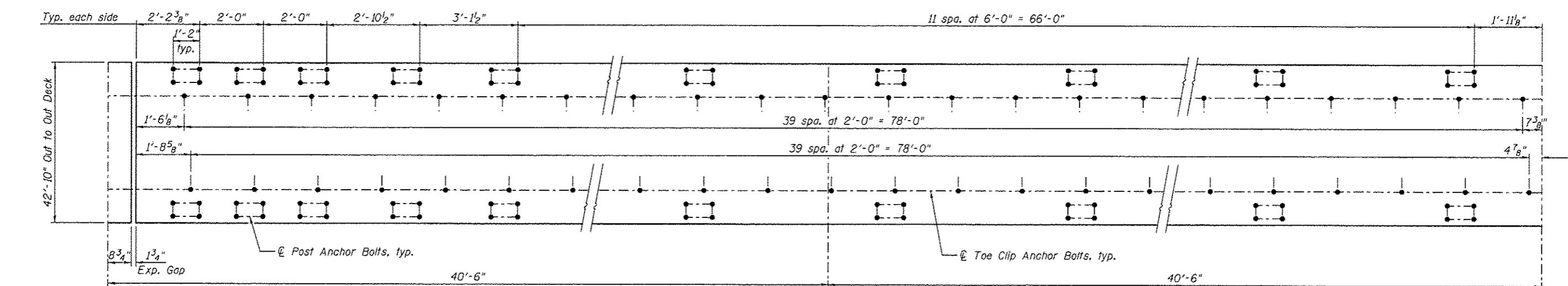
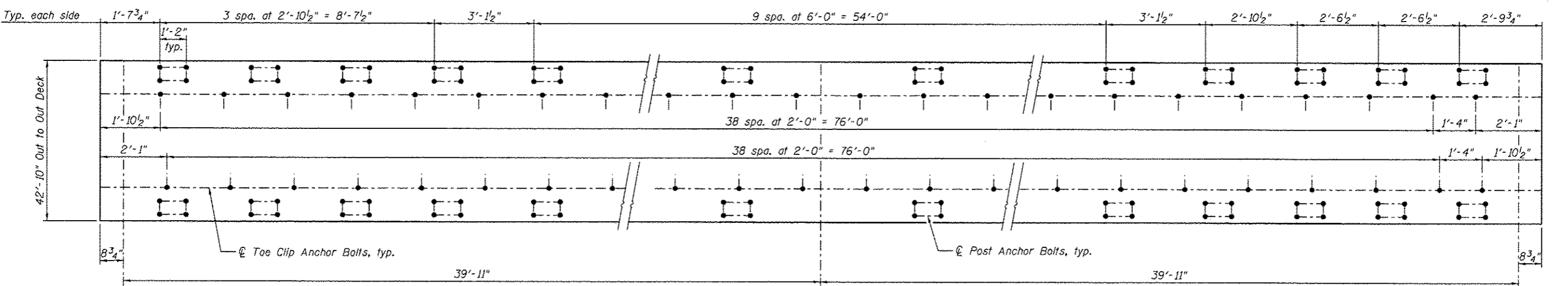
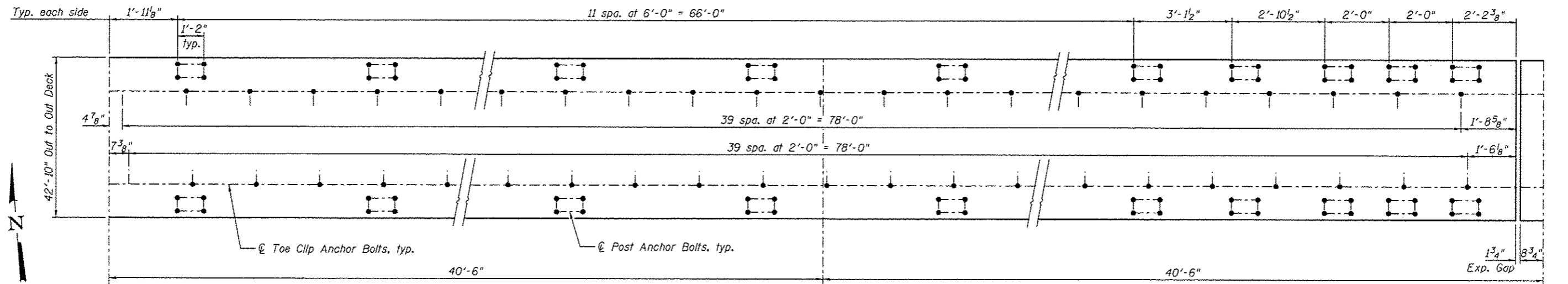

**ALUMINUM PARAPET POST AND TOE CLIP ANCHOR BOLT LAYOUT
SPAN 10 - PANEL POINT L23 TO L23'**

Notes:
 Layout is suggested. For list of layout constraints see Parapet Post Replacement Procedure at Grid Deck on sheet S33.
 For Grid Deck Details, see sheets S14 to S16.
 For Parapet Anchorage, see sheet S33.
 Toe clip anchor bolt layout shall match existing.



USER NAME :	DESIGNED - ZJB	REVISED
	CHECKED - YSS	REVISED
PLOT SCALE :	DRAWN - PRC	REVISED
PLOT DATE : 03/20/2014	CHECKED - ZJB	REVISED

**STATE OF ILLINOIS
DEPARTMENT OF TRANSPORTATION**

**MAIN SPANS ALUMINUM PARAPET DETAILS - GRID DECK L23-L23'
S.N. 082-6001 MLK BRIDGE OVER MISSISSIPPI RIVER**

F.A.P. RTE.	SECTION	COUNTY	TOTAL SHEETS	SHEET NO.
799	1BR, DRS-2	ST. CLAIR	156	56
CONTRACT NO. 76B03				

SHEET NO. S38 OF S138 SHEETS

ILLINOIS FED. AID PROJECT

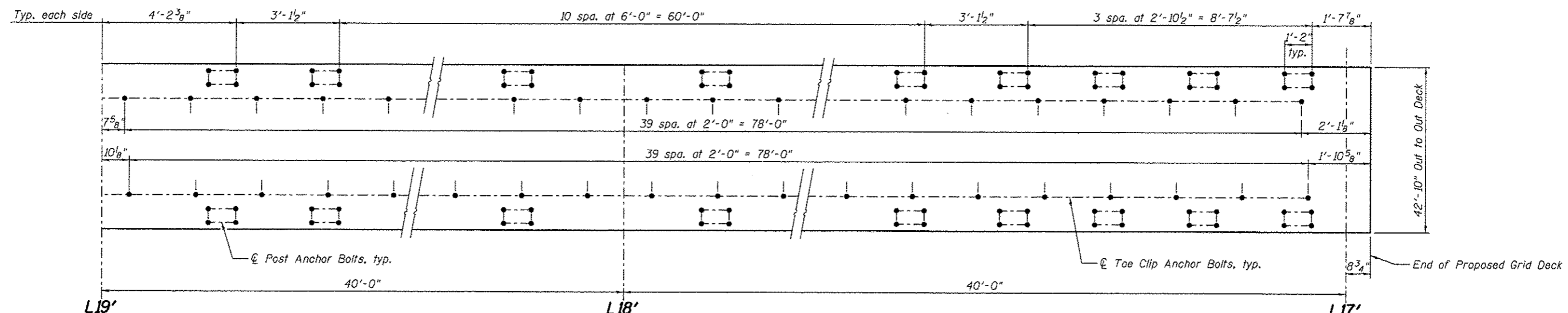
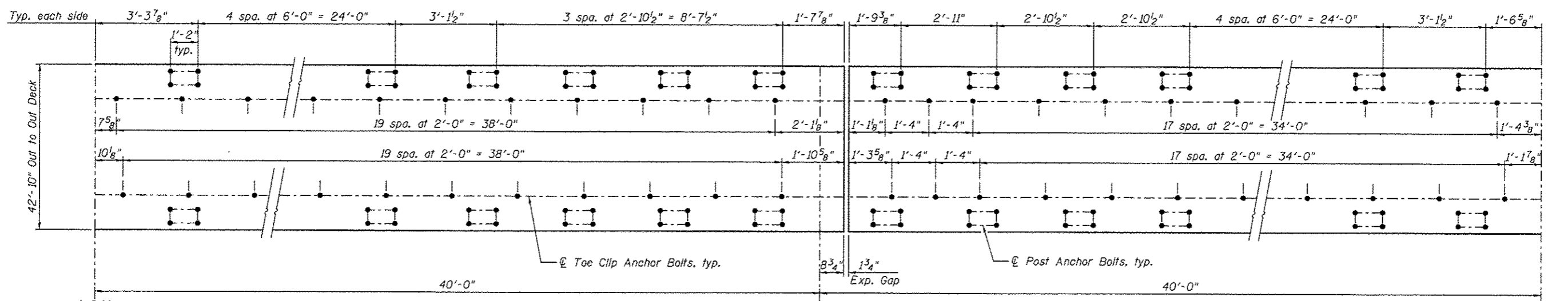
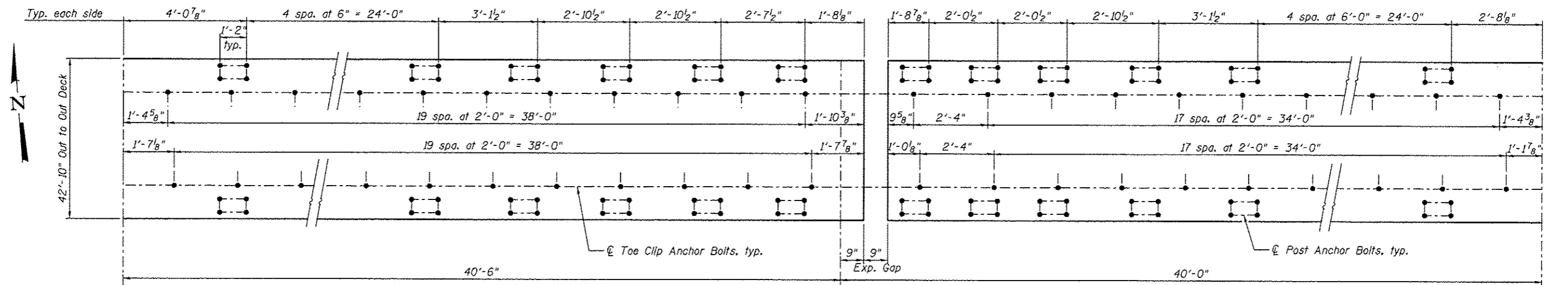

**ALUMINUM PARAPET POST AND TOE CLIP ANCHOR BOLT LAYOUT
SPAN 10 - PANEL POINT L23' TO L17'**

Notes:
Layout is suggested. For list of layout constraints see Parapet Post Replacement Procedure at Grid Deck on sheet S33.
For Grid Deck Details, see sheets S14 to S16.
For Parapet Anchorage, see sheet S33.
Toe clip anchor bolt layout shall match existing.



USER NAME =	DESIGNED - ZJB	REVISED
PLLOT SCALE =	CHECKED - YSS	REVISED
PLLOT DATE = 03/28/2014	DRAWN - PRC	REVISED
	CHECKED - ZJB	REVISED

**STATE OF ILLINOIS
DEPARTMENT OF TRANSPORTATION**

MAIN SPANS ALUMINUM PARAPET DETAILS - GRID DECK L23'-L17'
S.N. 082-6001 MLK BRIDGE OVER MISSISSIPPI RIVER

F.A.P. RTE. 799	SECTION 1BR, DRS-2	COUNTY ST. CLAIR	TOTAL SHEETS 156	SHEET NO. 57
SHEET NO. S39 OF S138 SHEETS				
ILLINOIS FED. AID PROJECT				

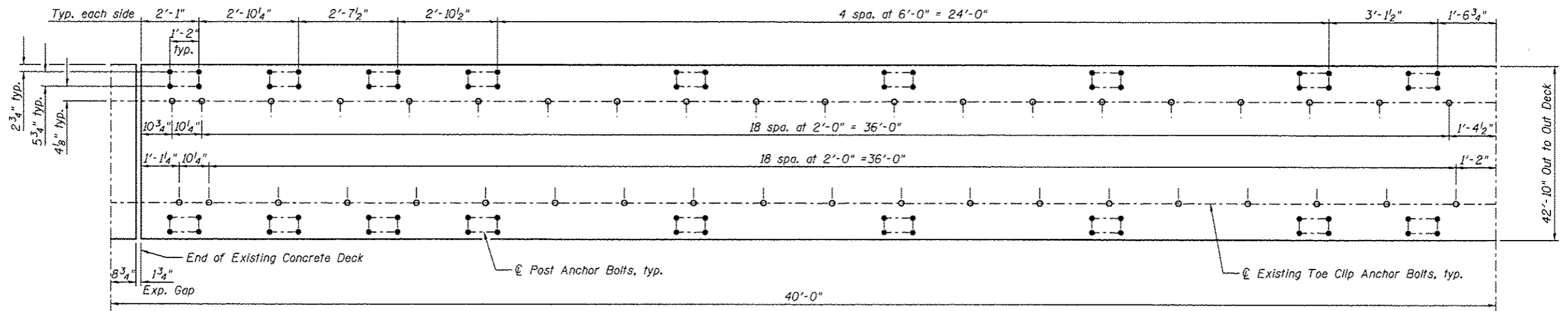
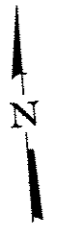

L17'

L16'

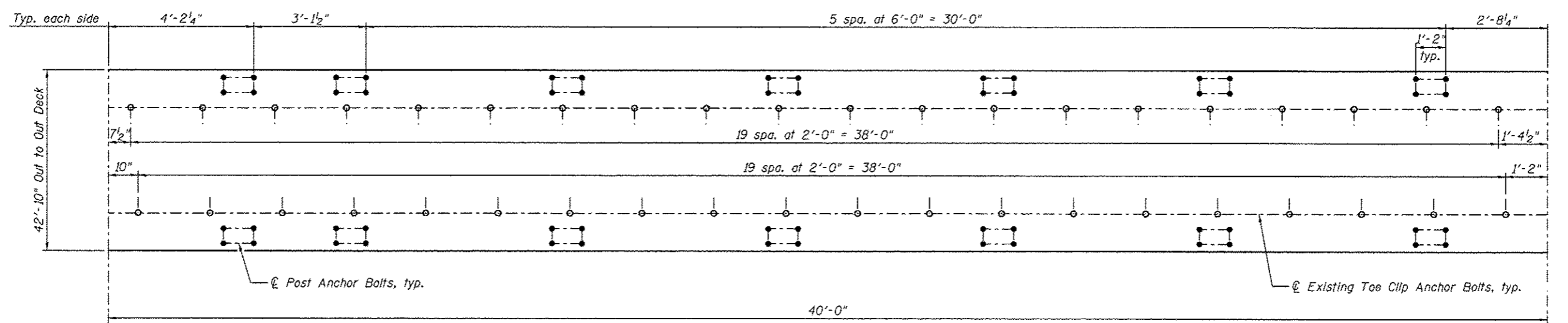

L16'

L15'

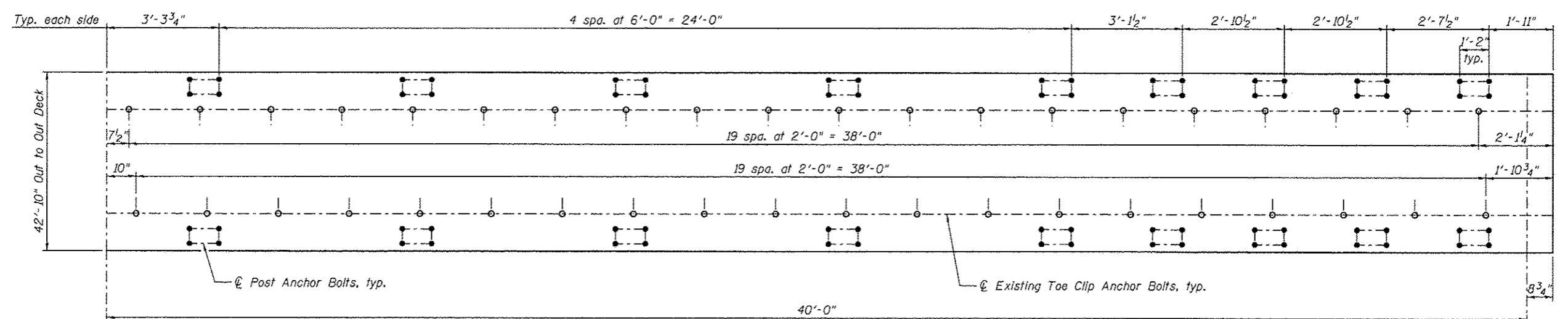

L15'

L14'

**ALUMINUM PARAPET POST ANCHOR BOLT LAYOUT
SPAN 10 - PANEL POINT L17' TO L14'**

Notes:
Layout is suggested. For list of layout constraints see Parapet Post Replacement Procedure at Concrete Deck on sheet S31.
Existing toe clip anchor bolts to remain in place. Spacing shown for information only.
For Parapet Anchorage, see sheet S31.



USER NAME =	DESIGNED - ZJB	REVISED
PLOT SCALE =	CHECKED - YSS	REVISED
PLOT DATE = 03/20/2014	DRAWN - PRC	REVISED
	CHECKED - ZJB	REVISED

STATE OF ILLINOIS
DEPARTMENT OF TRANSPORTATION

MAIN SPANS ALUMINUM PARAPET DETAILS - CONCRETE DECK L17'-L14'
S.N. 082-6001 MLK BRIDGE OVER MISSISSIPPI RIVER

F.A.P. RTE. 799	SECTION 1BR, DRS-2	COUNTY ST. CLAIR	TOTAL SHEETS 156	SHEET NO. 58
ILLINOIS FED. AID PROJECT				

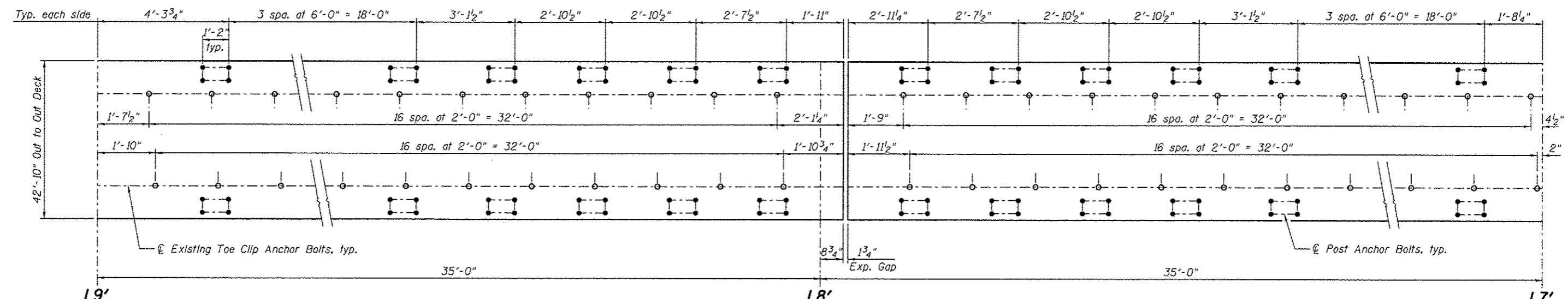
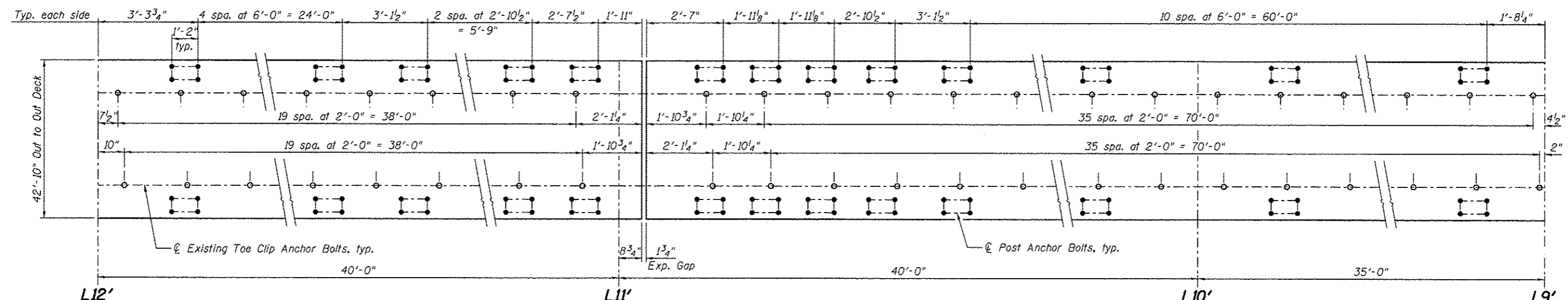
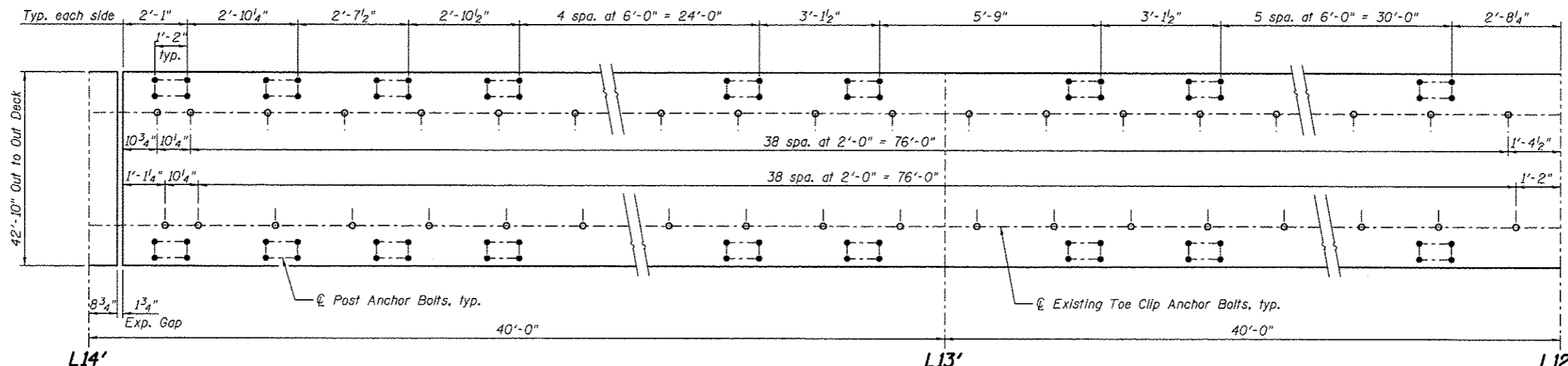
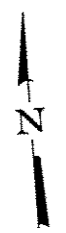

**ALUMINUM PARAPET POST ANCHOR BOLT LAYOUT
SPAN II - PANEL POINT L14' TO L7'**

Notes:
Layout is suggested. For list of layout constraints see Parapet Post Replacement Procedure at Concrete Deck on sheet S31.
Existing toe clip anchor bolts to remain in place. Spacing shown for information only.
For Parapet Anchorage, see sheet S31.



USER NAME *	DESIGNED - ZJB	REVISED
PLOT SCALE *	CHECKED - YSS	REVISED
PLOT DATE = 03/20/2014	DRAWN - PRC	REVISED
	CHECKED - ZJB	REVISED

**STATE OF ILLINOIS
DEPARTMENT OF TRANSPORTATION**

MAIN SPANS ALUMINUM PARAPET DETAILS - CONCRETE DECK L14'-L7'
S.N. 082-6001 MLK BRIDGE OVER MISSISSIPPI RIVER

F.A.P. RTE.	SECTION	COUNTY	TOTAL SHEETS	SHEET NO.
799	IBR, DRS-2	ST. CLAIR	156	59
CONTRACT NO. 76B03				
ILLINOIS FED. AID PROJECT				

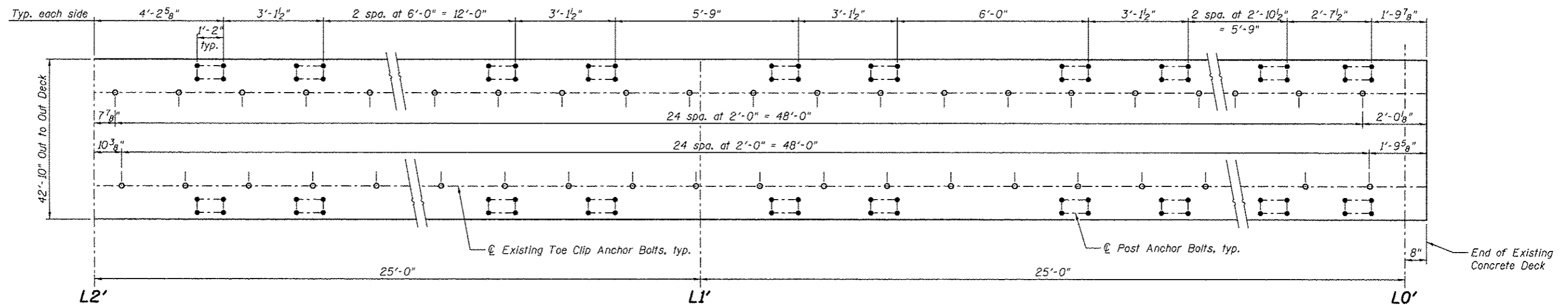
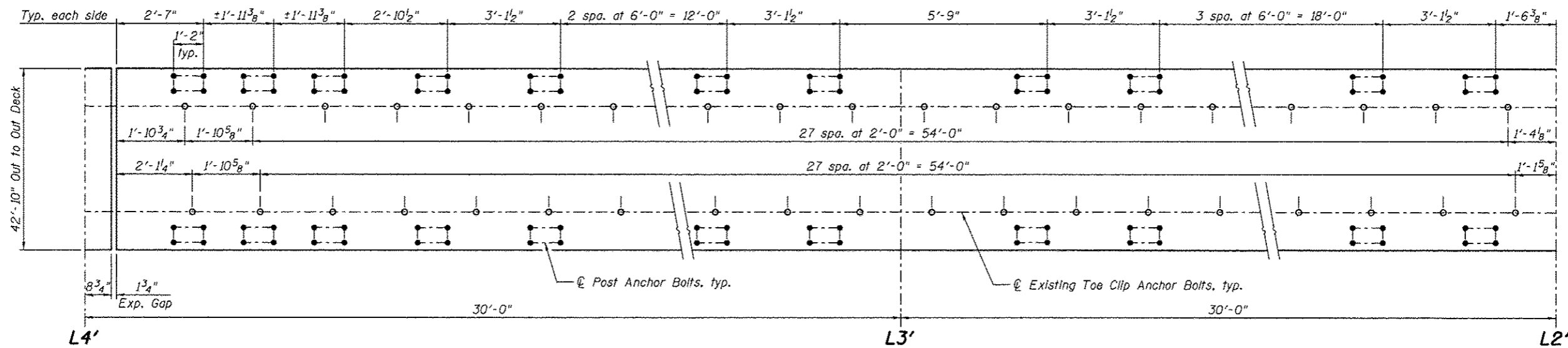
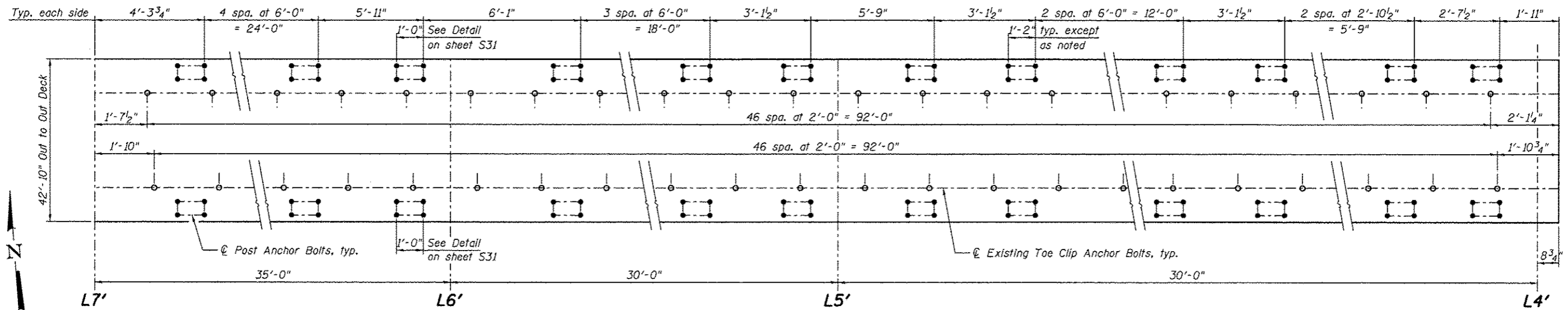

**ALUMINUM PARAPET POST ANCHOR BOLT LAYOUT
SPAN 11 - PANEL POINT L7' TO L0'**

Notes:
Layout is suggested. For list of layout constraints see Parapet Post Replacement Procedure at Concrete Deck on sheet S31.
Existing toe clip anchor bolts to remain in place. Spacing shown for information only.
For Parapet Anchorage, see sheet S31.



USER NAME =	DESIGNED - ZJB	REVISED
	CHECKED - YSS	REVISED
PLOT SCALE =	DRAWN - PRC	REVISED
PLOT DATE = 03/20/2014	CHECKED - ZJB	REVISED

**STATE OF ILLINOIS
DEPARTMENT OF TRANSPORTATION**

MAIN SPANS ALUMINUM PARAPET DETAILS - CONCRETE DECK L7'-L0'
S.N. 082-6001 MLK BRIDGE OVER MISSISSIPPI RIVER

SHEET NO. 542 OF 5138 SHEETS

F.A.P. RTE.	SECTION	COUNTY	TOTAL SHEETS	SHEET NO.
799	1BR, DRS-2	ST. CLAIR	156	60
			CONTRACT NO. 76B03	
ILLINOIS FED. AID PROJECT				

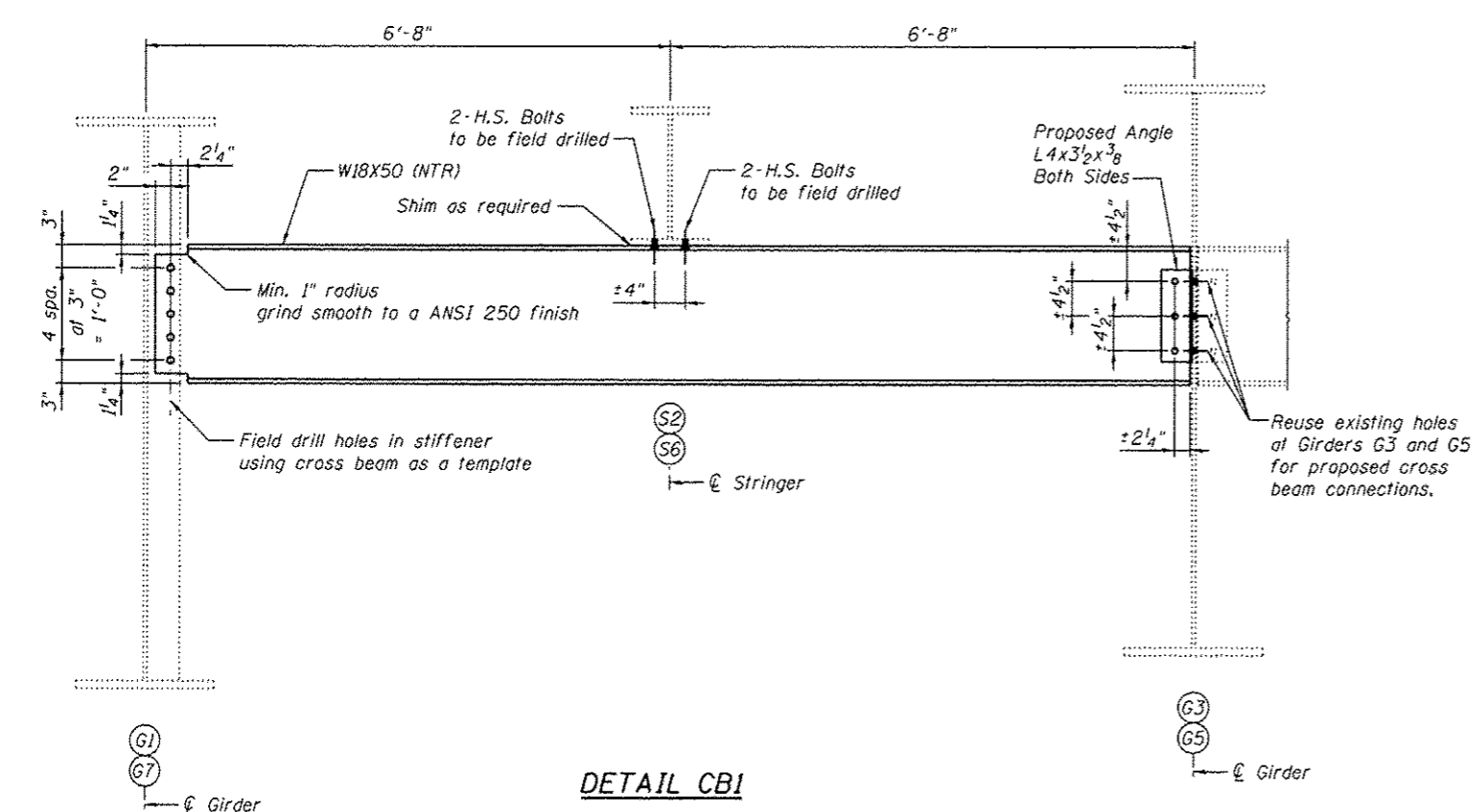
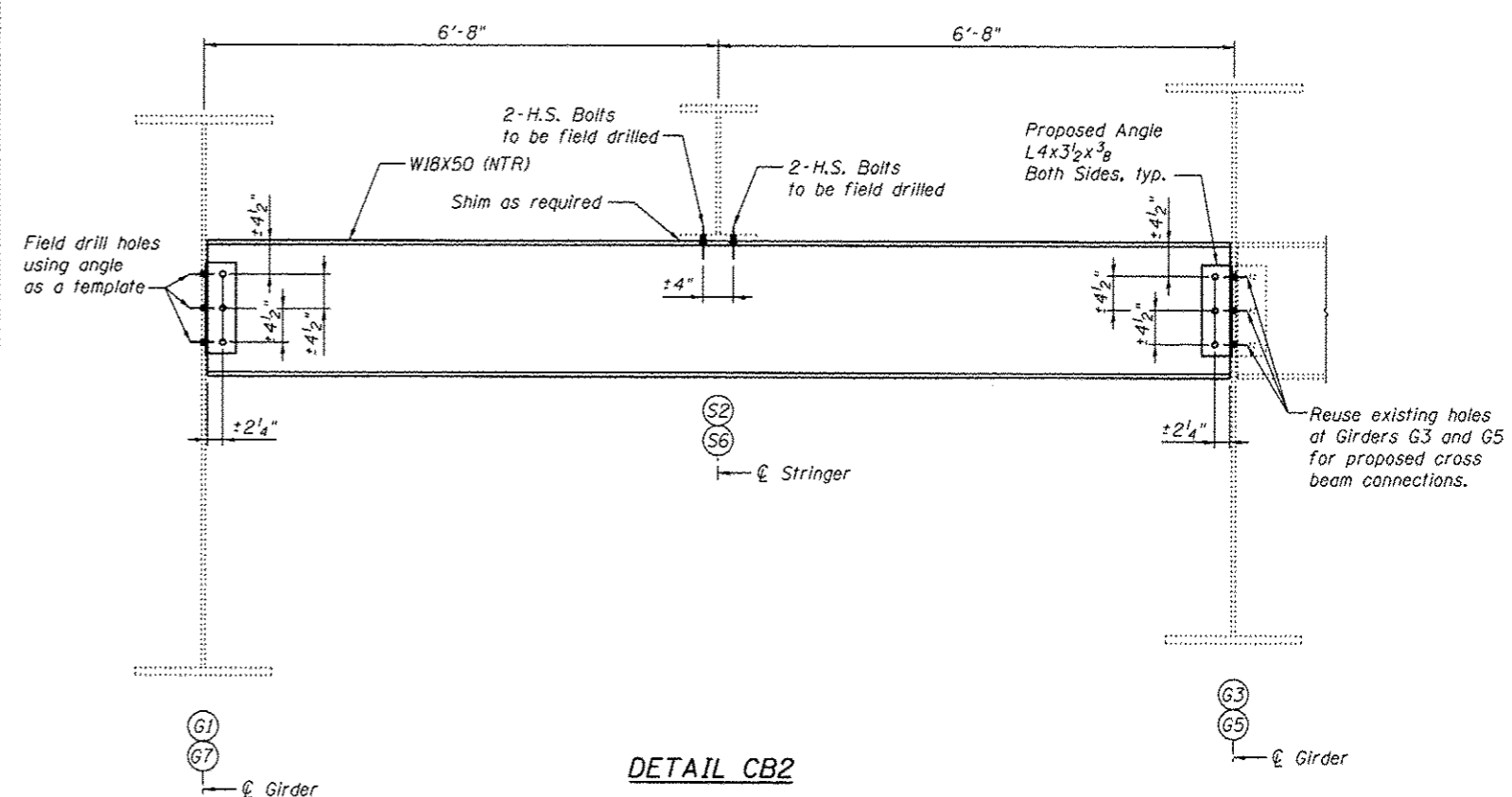
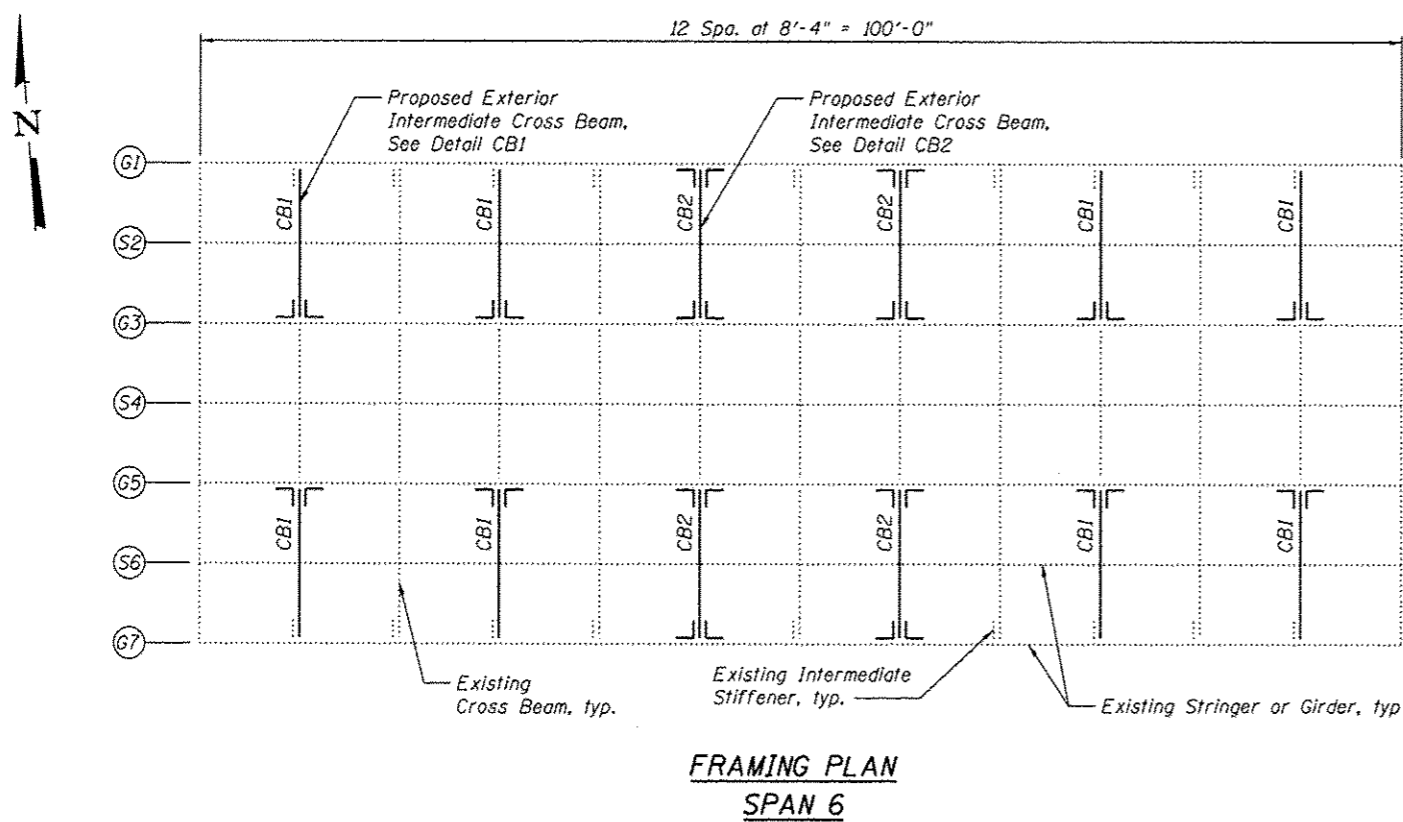

Procedure
Install cross beams between Girders G1 and G3 and G5 and G7 to provide additional support for Stringers S2 and S6.
Clip cross beam flanges as approved by the Engineer if required for installation.

BILL OF MATERIAL

Item	Unit	Total
Structural Steel Repair	Pound	8330

Notes:
All bolted connections shown on this sheet shall be made with 3/4" dia. H.S. bolts.
Load carrying components designed "NTR" shall conform to the Impact Testing Requirement, Zone 2.

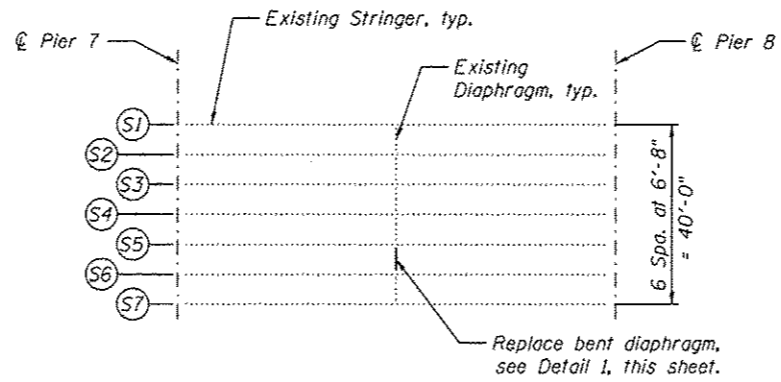

FRAMING PLAN
SPAN 8

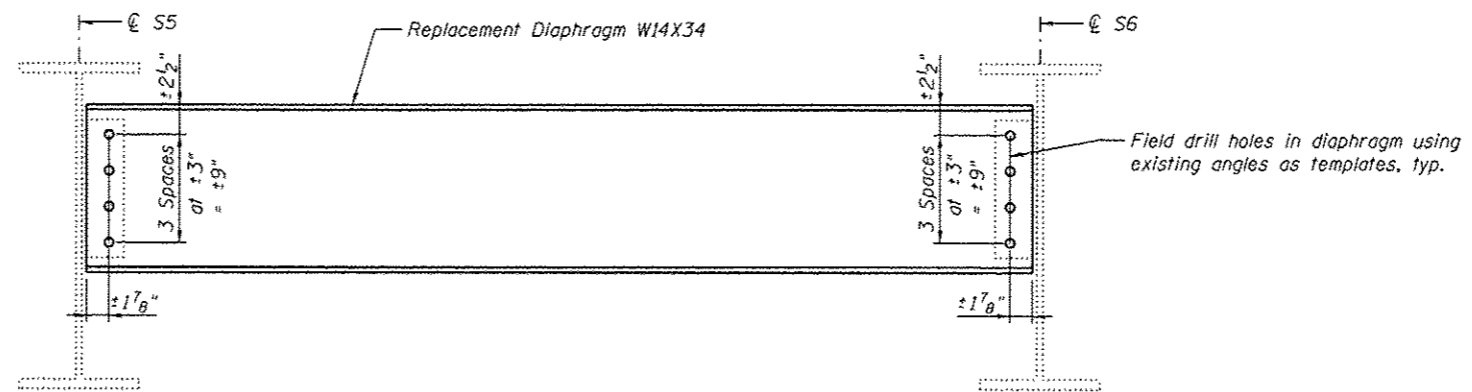

DETAIL 1
(Looking East)

BILL OF MATERIAL

Item	Unit	Total
Structural Steel Repair	Pound	230

Notes:
All bolted connections shown on this sheet shall be made with 3/4" dia. H.S. bolts.
Clip diaphragm flanges as approved by the Engineer if required for installation.



USER NAME :	DESIGNED - CDB	REVISED
	CHECKED - JMH	REVISED
PLOT SCALE :	DRAWN - AEC	REVISED
PLOT DATE : 05/02/2014	CHECKED - CDB	REVISED

STATE OF ILLINOIS
DEPARTMENT OF TRANSPORTATION

MISSOURI APPROACH SPAN 8 DIAPHRAGM REPLACEMENT
S.N. 082-6001 MLK BRIDGE OVER MISSISSIPPI RIVER

SHEET NO. S44 OF S138 SHEETS

F.A.P. RTE.	SECTION	COUNTY	TOTAL SHEETS	SHEET NO.
799	IBR, DRS-2	ST. CLAIR	156	62
			CONTRACT NO. 76B03	
ILLINOIS FED. AID PROJECT				

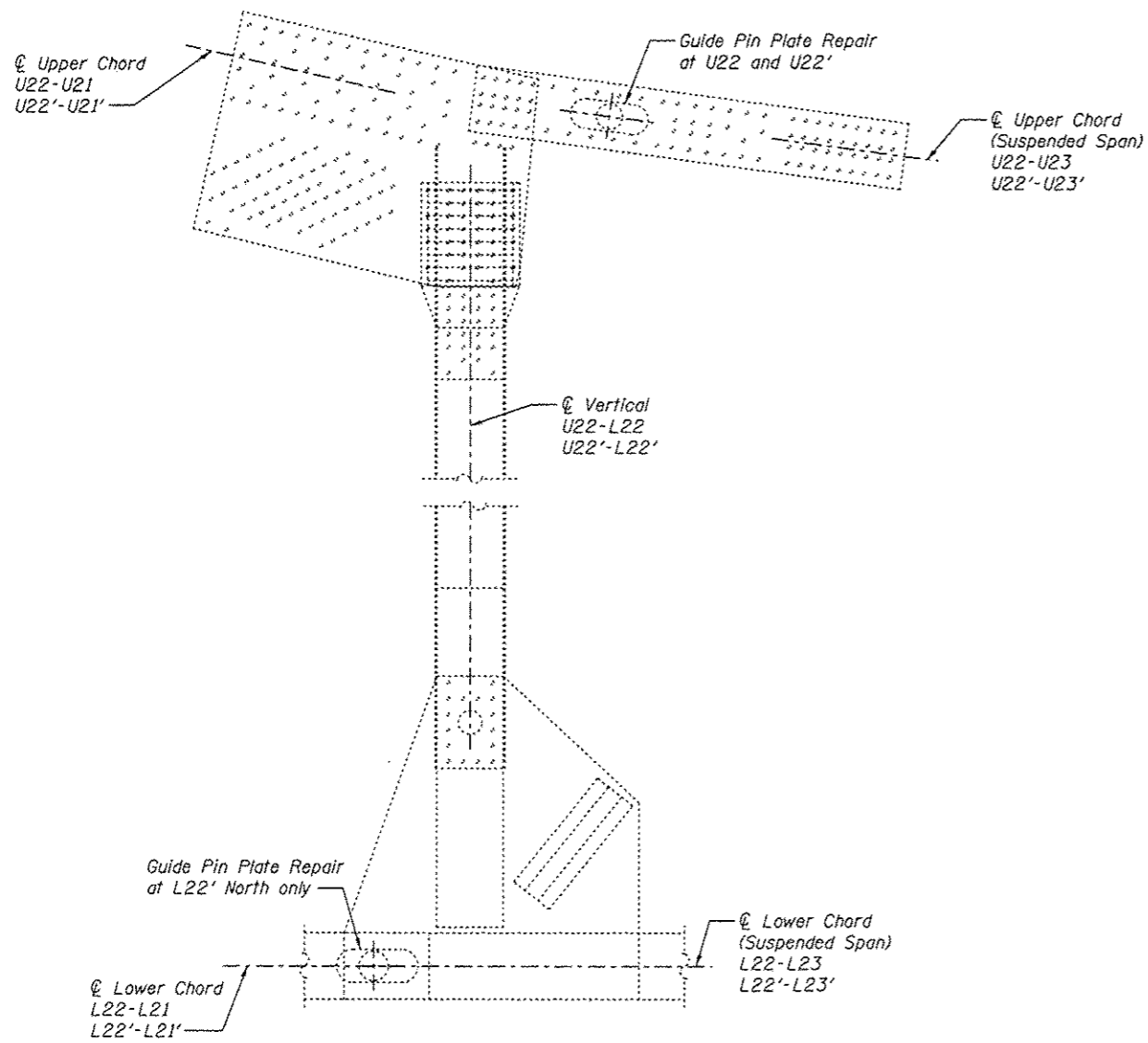

GUIDE PIN PLATE REPAIR U22-L22
(U22'-L22' SIMILAR)
 North and South Truss

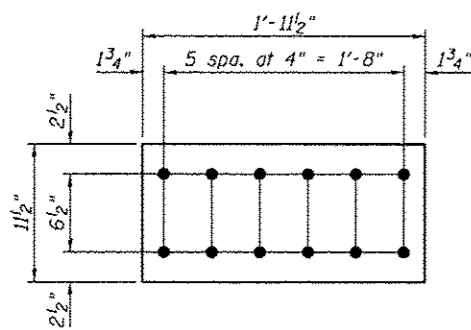

BASE P GPI
 $P \frac{1}{2} \times 1 \frac{1}{2} \times 1' - 11 \frac{1}{2}$

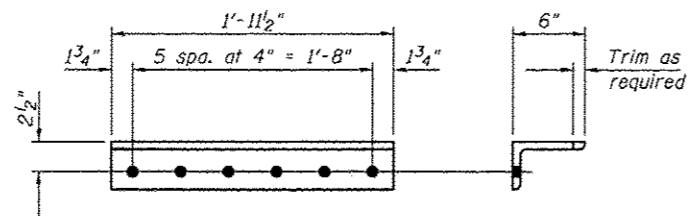

SUPPORT ANGLE GP2
 $L6 \times 4 \times \frac{7}{8}$

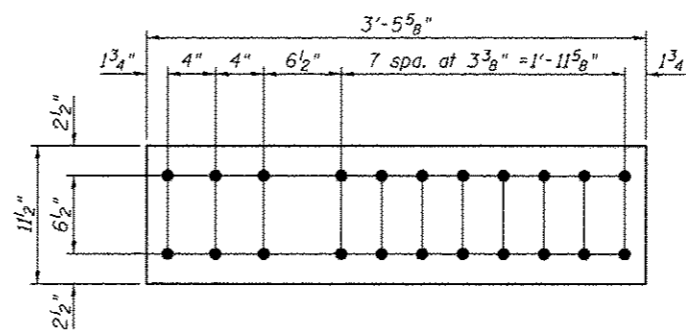

BASE P GP3
 $P \frac{1}{2} \times 1 \frac{1}{2} \times 3' - 5 \frac{5}{8}$

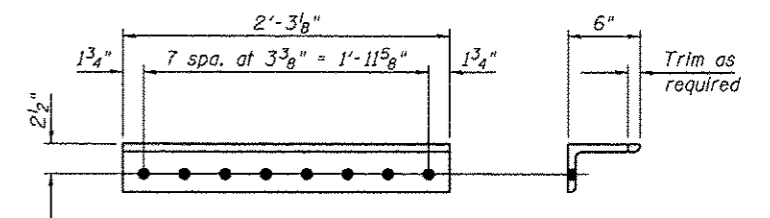
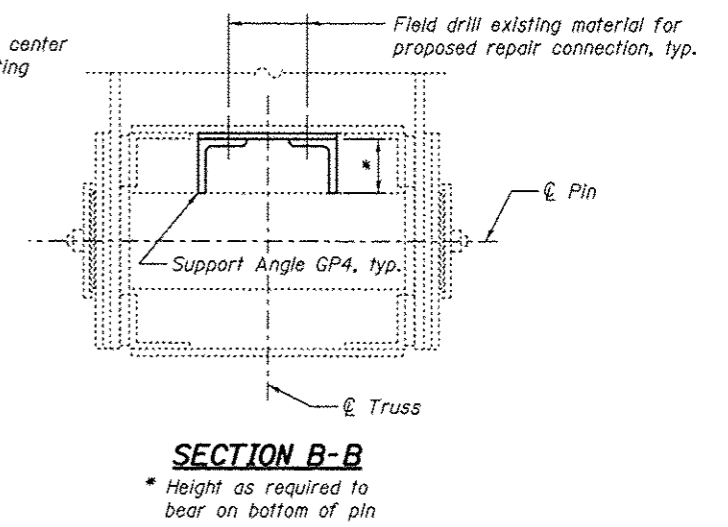
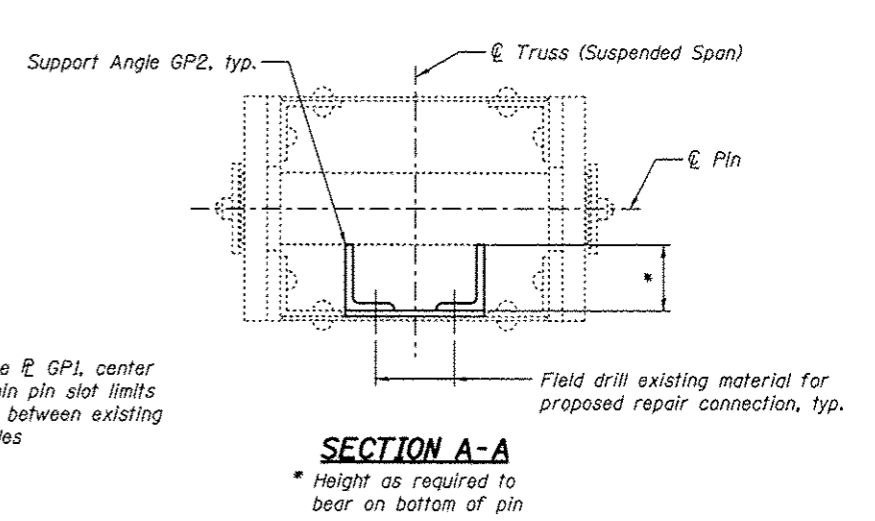
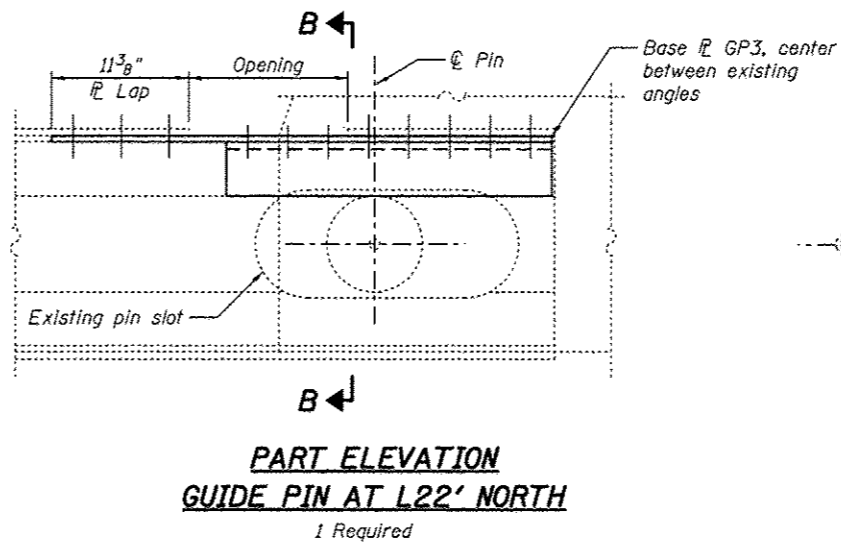
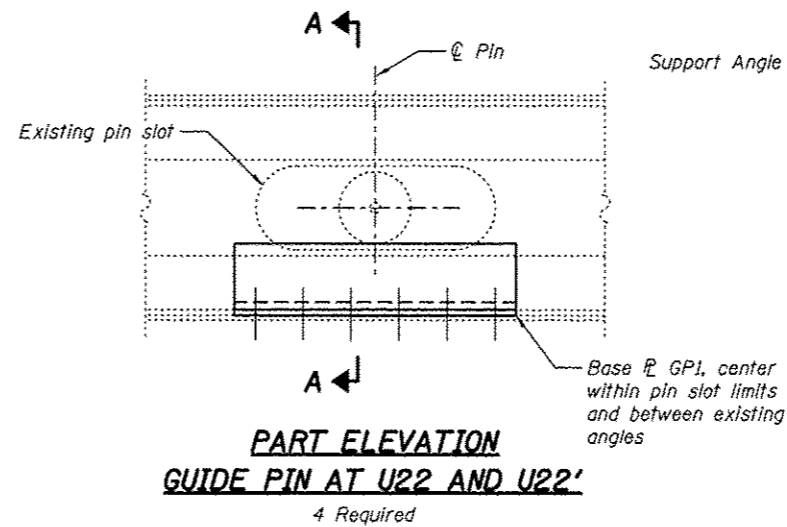

SUPPORT ANGLE GP4
 $L6 \times 4 \times \frac{7}{8}$

BILL OF MATERIAL

Item	Unit	Total
Structural Steel Repair	Pound	840



USER NAME *	DESIGNED - PRC	REVISED
	CHECKED - CDB	REVISED
PLOT SCALE *	DRAWN - PRC	REVISED
PLOT DATE *	CHECKED - CDB	REVISED

STATE OF ILLINOIS
 DEPARTMENT OF TRANSPORTATION

MAIN SPANS GUIDE PIN PLATE REPAIR
 S.N. 082-6001 MLK BRIDGE OVER MISSISSIPPI RIVER

SHEET NO. 545 OF 5138 SHEETS

F.A.P. RTE.	SECTION	COUNTY	TOTAL SHEETS	SHEET NO.
799	18R, ORS-2	ST. CLAIR	156	63
CONTRACT NO. 76B03				
ILLINOIS FED. AID PROJECT				

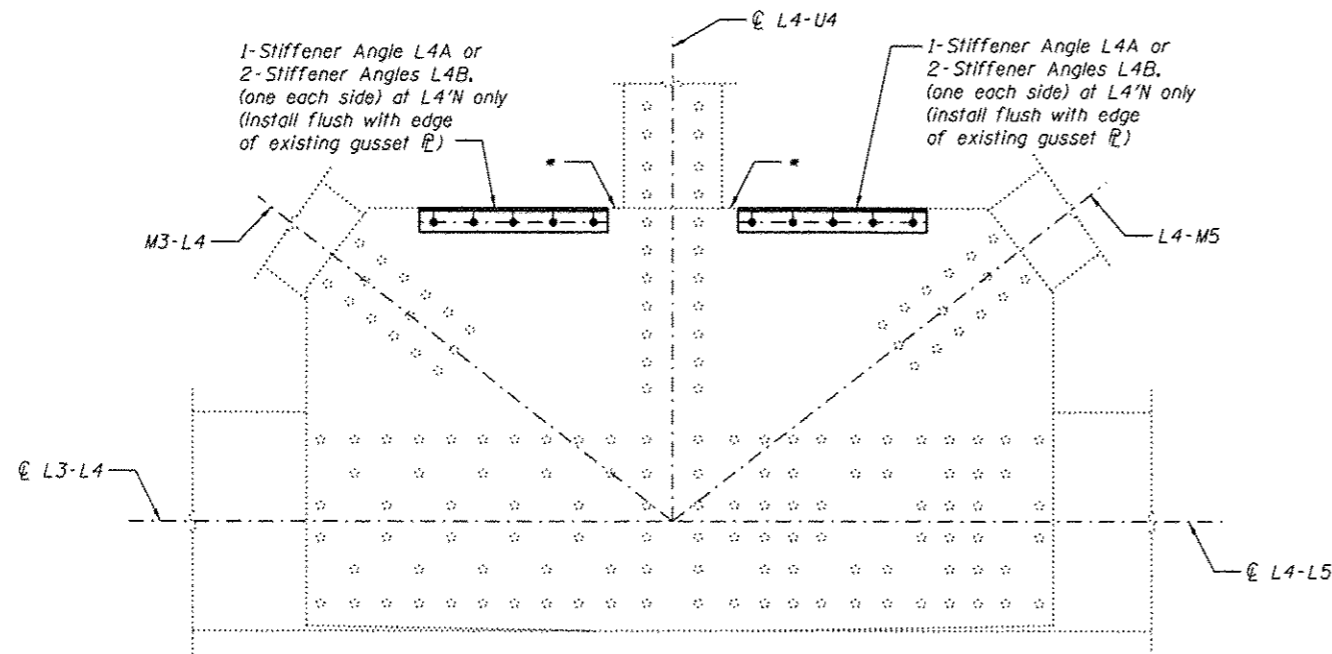

OUTSIDE PLATE AT PANEL POINT L4N AND L4S
(L4'N AND L4'S SIMILAR)
 (Span 9 and 11)

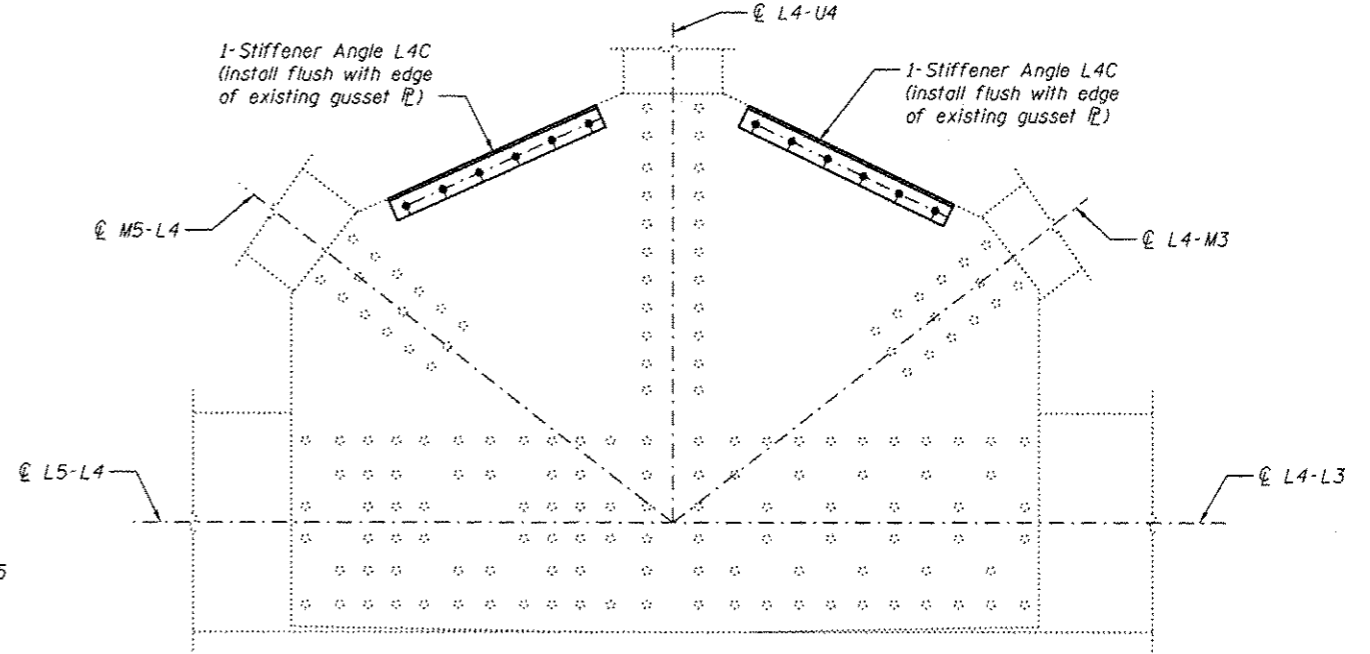

INSIDE PLATE AT PANEL POINT L4N AND L4S
(L4'N AND L4'S SIMILAR)
 (Span 9 and 11)

Outside gusset plate at L4'N is warped both sides of vertical L4-U4. Plates shall be straightened prior to attaching stiffener angles. Contractor shall submit a straightening procedure to the Engineer for review and approval prior to the performing work.

GUSSET PLATE STRENGTHENING

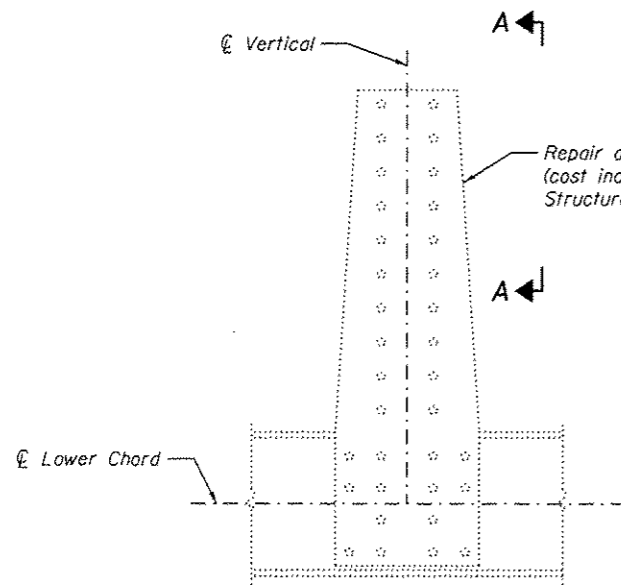

INSIDE PLATE AT PANEL POINT L25N
 (Span 10)

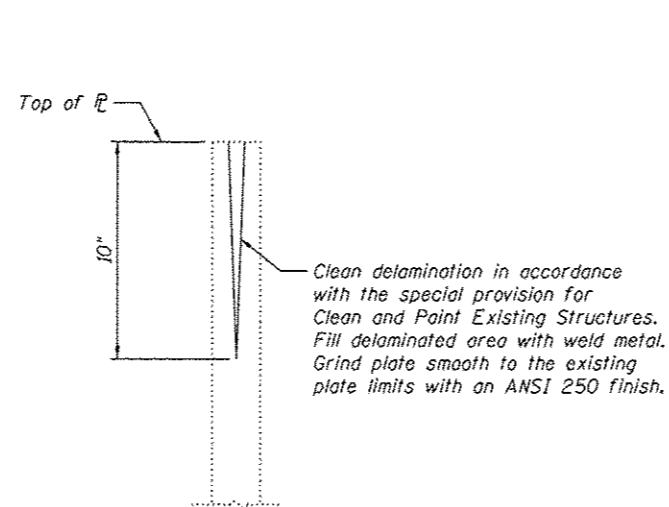

VIEW A-A

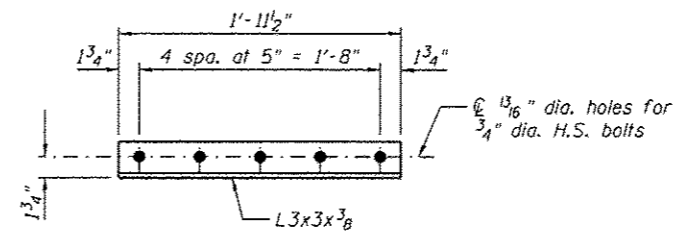

STIFFENER ANGLE L4A

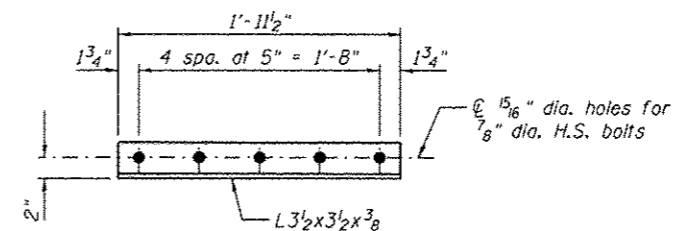

STIFFENER ANGLE L4B

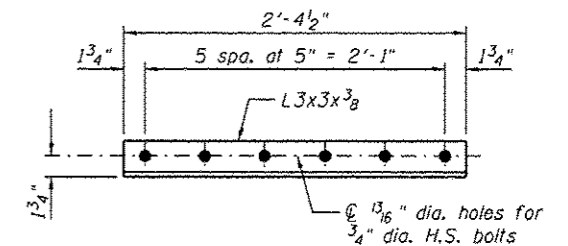

STIFFENER ANGLE L4C

Notes:
 Field drill holes in existing gusset plate using new material as template.

BILL OF MATERIAL

Item	Unit	Total
Structural Steel Repair	Pound	340



USER NAME *	DESIGNED - MEL	REVISED
PLOT SCALE *	CHECKED - CDB	REVISED
PLOT DATE * 05/02/2014	DRAWN - PRC	REVISED
	CHECKED - MEL	REVISED

STATE OF ILLINOIS
DEPARTMENT OF TRANSPORTATION

MAIN SPANS GUSSET PLATE STRENGTHENING - 2
S.N. 082-6001 MLK BRIDGE OVER MISSISSIPPI RIVER

SHEET NO. S47 OF S138 SHEETS

F.A.P. RTE.	SECTION	COUNTY	TOTAL SHEETS	SHEET NO.
799	1BR, DRS-2	ST. CLAIR	156	65
			CONTRACT NO. 76B03	
ILLINOIS FED. AID PROJECT				

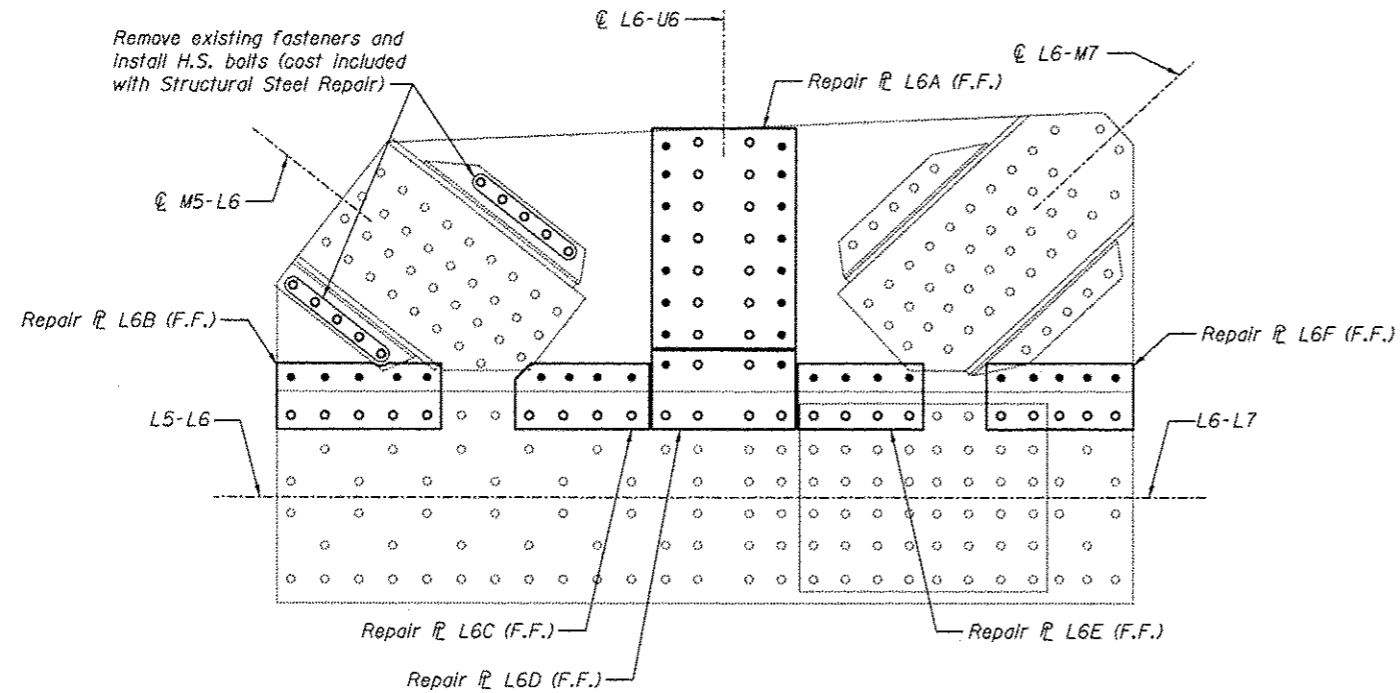

OUTSIDE PLATE AT PANEL POINT L6N AND L6S
(L6'N AND L6'S SIMILAR)
 (Span 9 and Span 11)

GUSSET PLATE STRENGTHENING

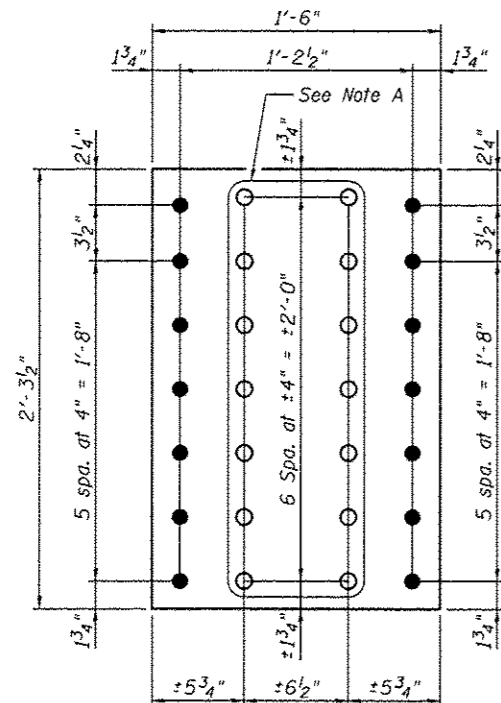

REPAIR P L6A
 P 1 1/4" x 18" x 2'-3 1/2"

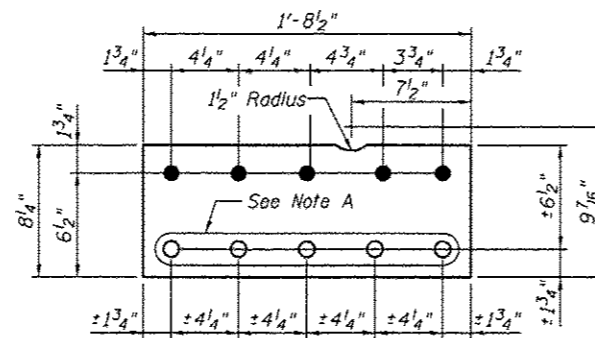

REPAIR P L6B
 P 1 1/4" x 8 1/4" x 1'-8 1/2"

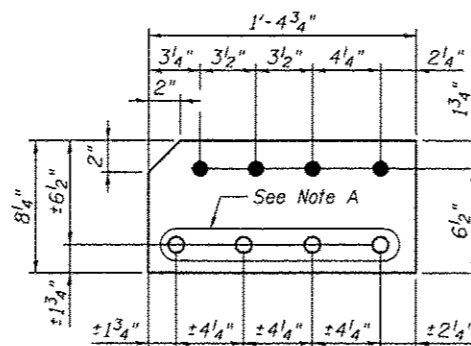

REPAIR P L6C
 P 7/8" x 8 1/4" x 1'-4 3/4"

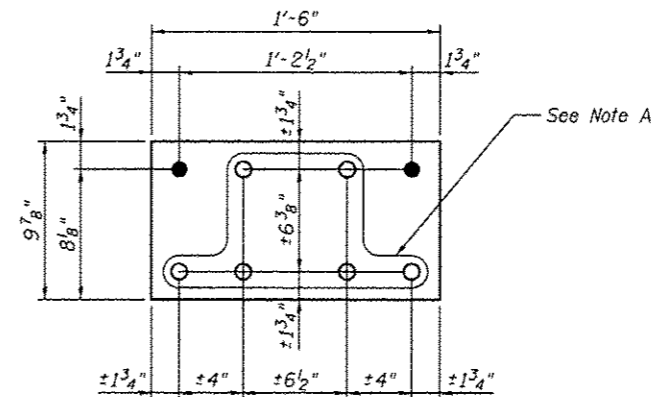

REPAIR P L6D
 P 7/8" x 9 7/8" x 1'-6"

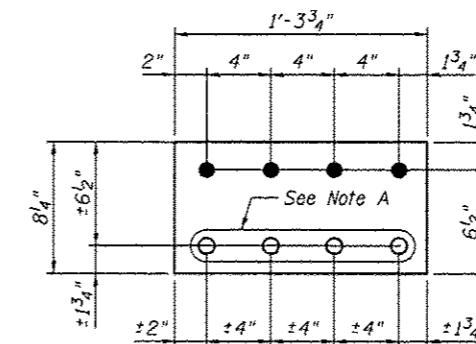

REPAIR P L6E
 P 7/8" x 8 1/4" x 1'-3 3/4"

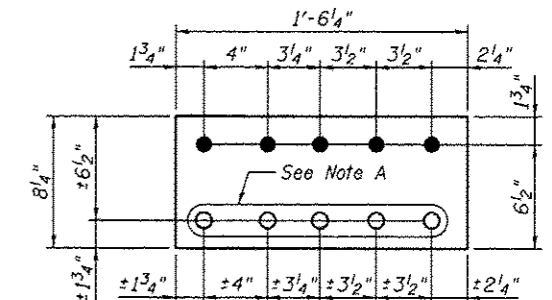

REPAIR P L6F
 P 1 1/4" x 8 1/4" x 1'-6 1/4"

Procedure
 Remove the bottom lateral connection plate and angle; then install repair plates, angles and fills, as shown, one side at a time on the inside gusset plate. Install remaining repair plates and fills, one at a time, on the inside gusset plate, followed by the installation of the repair plates, one at a time, on the outside gusset plate.

If additional fasteners need to be removed other than those shown on this sheet, the Contractor shall submit a procedure for review and approval. If needed, the Contractor shall provide temporary support for floorbeams and joints.

BILL OF MATERIAL

Item	Unit	Total
Structural Steel Repair	Pound	4,870

Note A:
 Field drill holes using existing holes as template.
 Remainder of holes may be shop or field drilled.

Notes:
 All bolted connections shown on this sheet shall be made with 1" dia. H.S. bolts unless otherwise noted.
 For L6 inside gusset P, see sheet S49.
 For front face of gusset P, see sheet S8.



USER NAME =	DESIGNED - MEL/YSS	REVISED
	CHECKED - COB	REVISED
PLOT SCALE =	DRAWN - AEC	REVISED
PLOT DATE = 05/09/2014	CHECKED - MEL	REVISED

STATE OF ILLINOIS
 DEPARTMENT OF TRANSPORTATION

MAIN SPAN GUSSET PLATE STRENGTHENING - 3
 S.N. 082-6001 MLK BRIDGE OVER MISSISSIPPI RIVER

SHEET NO. S48 OF S138 SHEETS

F.A.P. RTE.	SECTION	COUNTY	TOTAL SHEETS	SHEET NO.
799	1BR, ORS-2	ST. CLAIR	156	66
ILLINOIS FED. AID PROJECT			CONTRACT NO. 76B03	

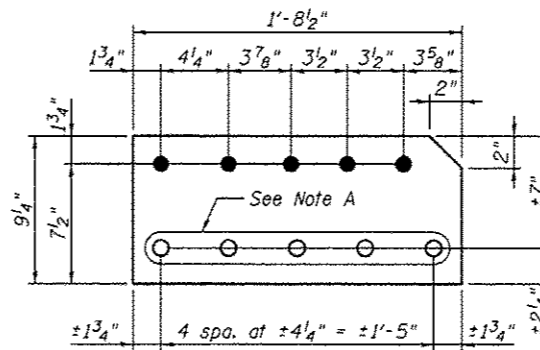
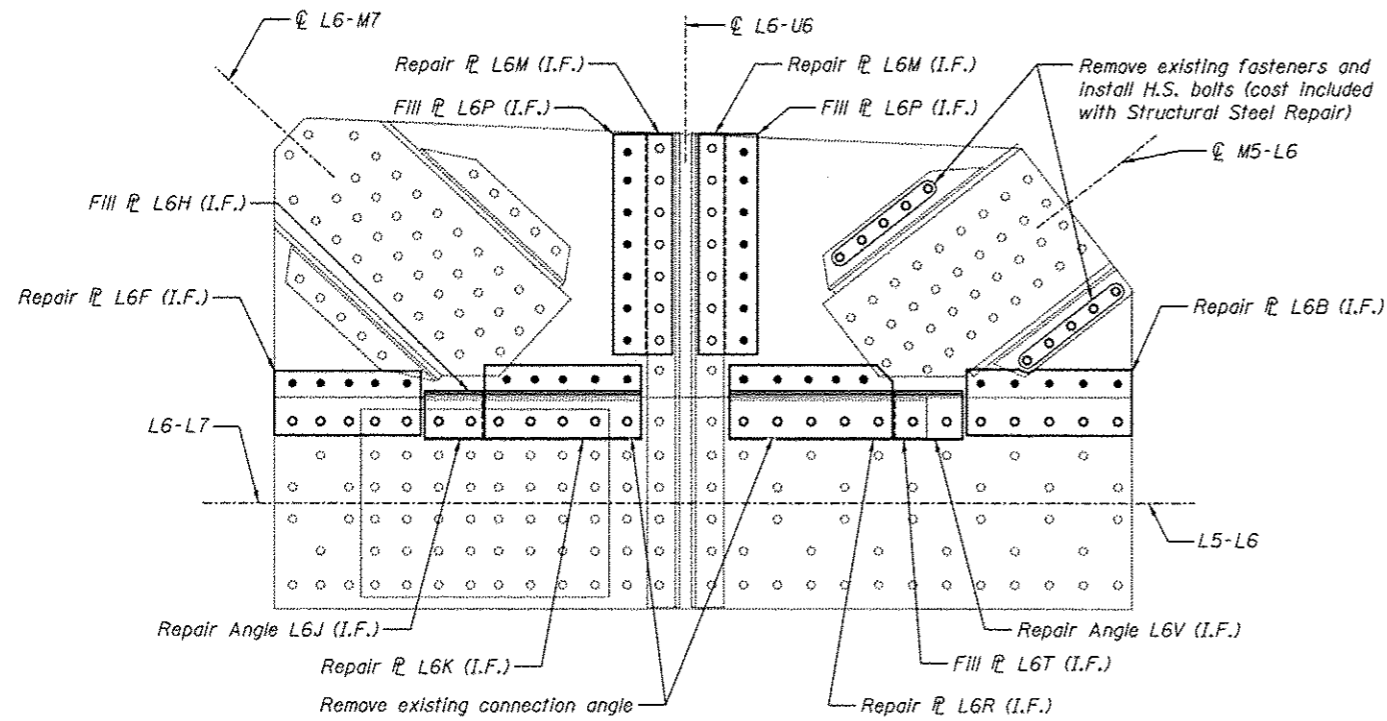

REPAIR P L6R
 P 7/8" x 9 1/4" x 1'-8 1/2"

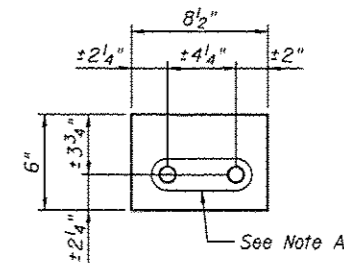

FILL P L6T
 P 7/8" x 6" x 8 1/2"

INSIDE PLATE AT PANEL POINT L6N AND L6S
(L6'N AND L6'S SIMILAR)
 (Span 9 and Span 11)

GUSSET PLATE STRENGTHENING

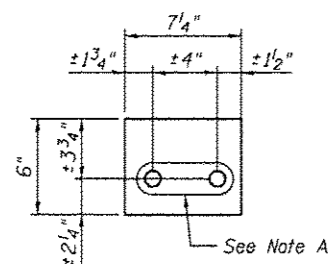

FILL P L6H
 P 7/8" x 6" x 7 1/4"

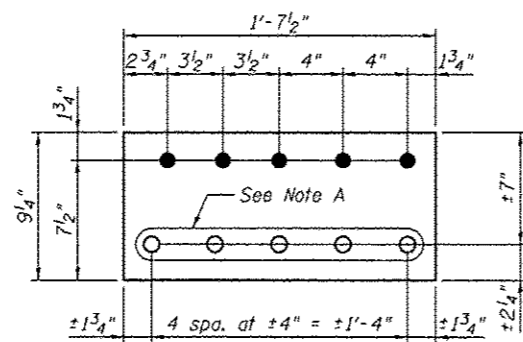

REPAIR P L6K
 P 7/8" x 9 1/4" x 1'-7 1/2"

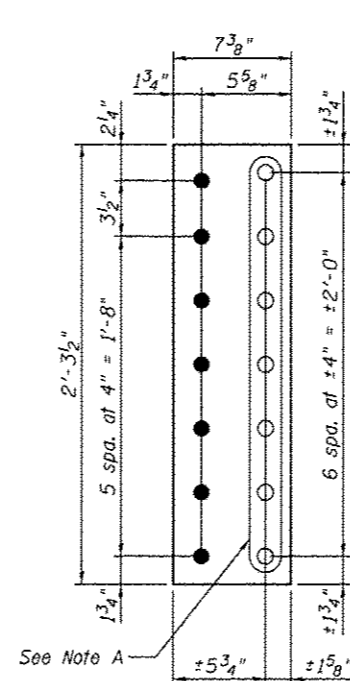

REPAIR P L6M
 P 1 1/4" x 7 3/8" x 2'-3 1/2"

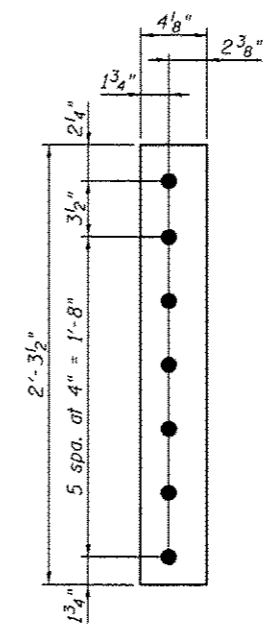

FILL P L6P
 P 1/2" x 4 1/8" x 2'-3 1/2"

Note A:
 Field drill holes using existing holes as template.
 Remainder of holes may be shop or field drilled.

Notes:
 For the Installation Procedure and Bill of Material, see sheet S48.
 For details of pieces, L6F and L6B, see sheet S48.
 For details of pieces, L6J and L6V, see sheet S49A.
 For location and details of lateral connection repair plates, see sheet S49A.
 All bolted connections shown on this sheet shall be made with 1" dia. H.S. bolts unless otherwise noted.
 For inside face of gusset plate, see sheet S8.



USER NAME *	DESIGNED - MEL/YSS	REVISED
	CHECKED - COB	REVISED
PLOT SCALE *	DRAWN - AEC	REVISED
PLOT DATE * 05/09/2014	CHECKED - MEL	REVISED

STATE OF ILLINOIS
 DEPARTMENT OF TRANSPORTATION

MAIN SPAN GUSSET PLATE STRENGTHENING - 4
 S.N. 082-6001 MLK BRIDGE OVER MISSISSIPPI RIVER

SHEET NO. S49 OF S138 SHEETS

F.A.P. RTE.	SECTION	COUNTY	TOTAL SHEETS	SHEET NO.
799	1BR, DRS-2	ST. CLAIR	156	67
CONTRACT NO. 76B03				
ILLINOIS FED. AID PROJECT				

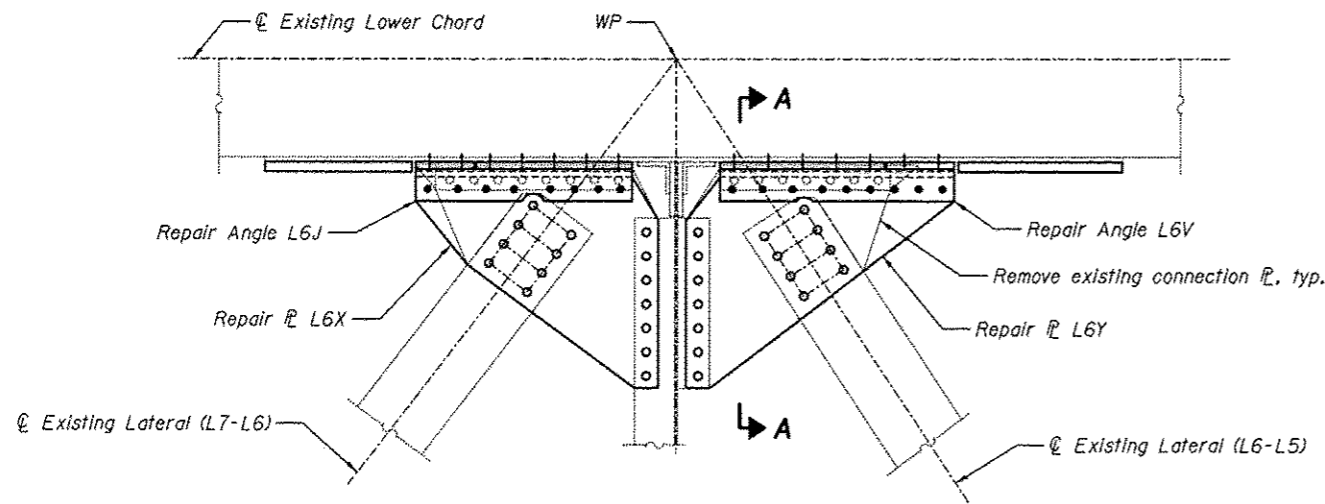

LOWER LATERAL AT PANEL POINT L6N AND L6S
(L6'N AND L6'S SIMILAR)
 (Span 9 and Span 11)

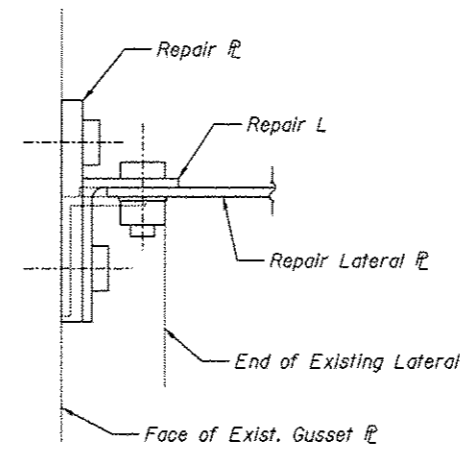

SECTION A-A

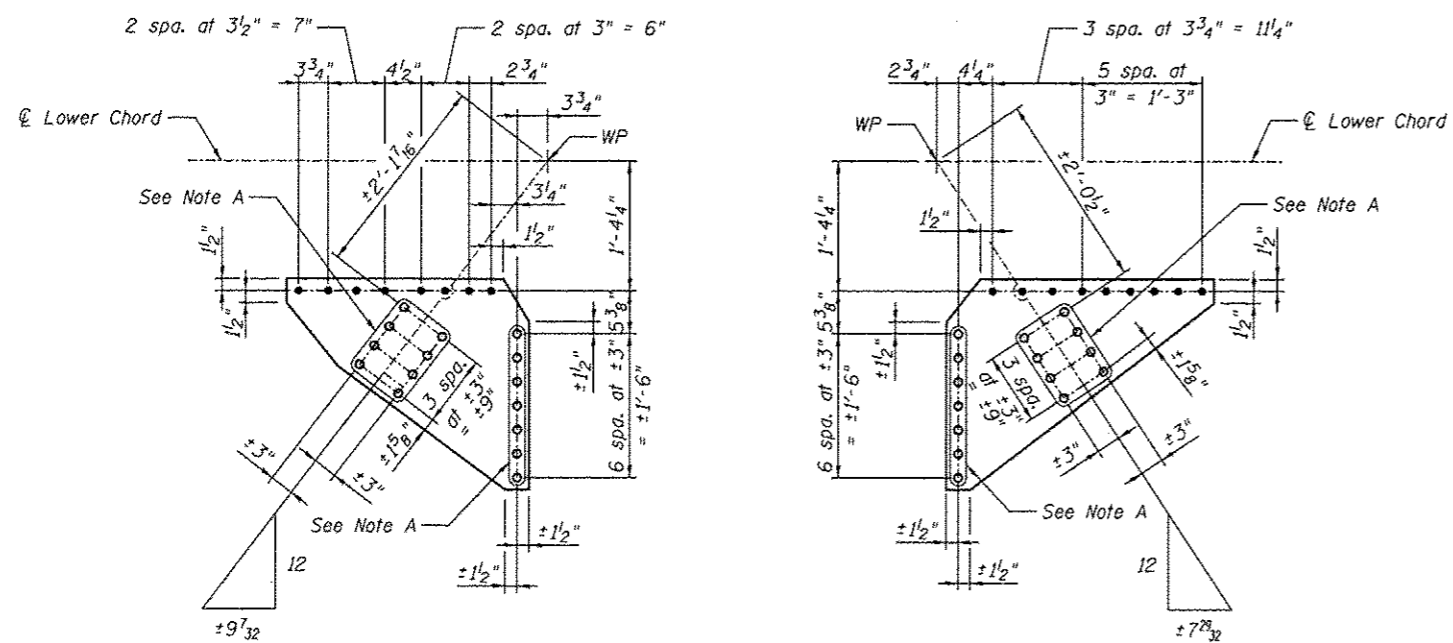

REPAIR ANGLE L6X
 L 3/8" x 26 3/8" x 2'-6 1/4"

Note: Repair ANGLE L6X requires
 15/16" ϕ holes for 7/8" ϕ H.S. bolts.

REPAIR ANGLE L6Y
 L 3/8" x 26 3/8" x 2'-9 1/2"

Note: Repair ANGLE L6Y requires
 15/16" ϕ holes for 7/8" ϕ H.S. bolts.

Note A:
 Field drill holes using existing holes as template.
 Remainder of holes may be shop or field drilled.

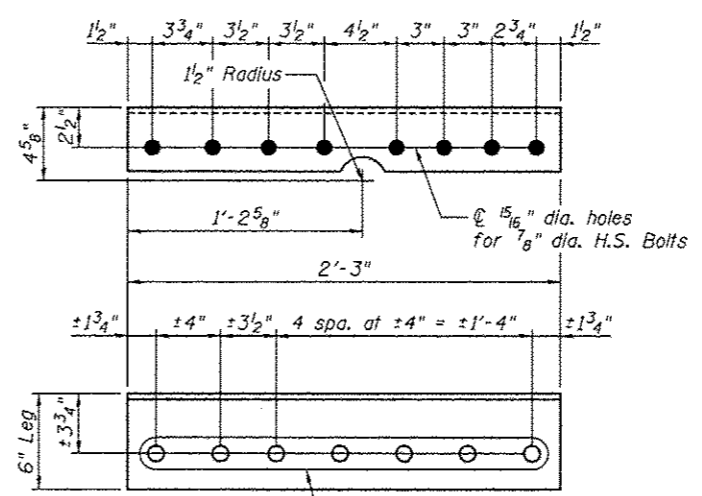

REPAIR ANGLE L6J
 L6 x 4 x 3/8 x 2'-3"

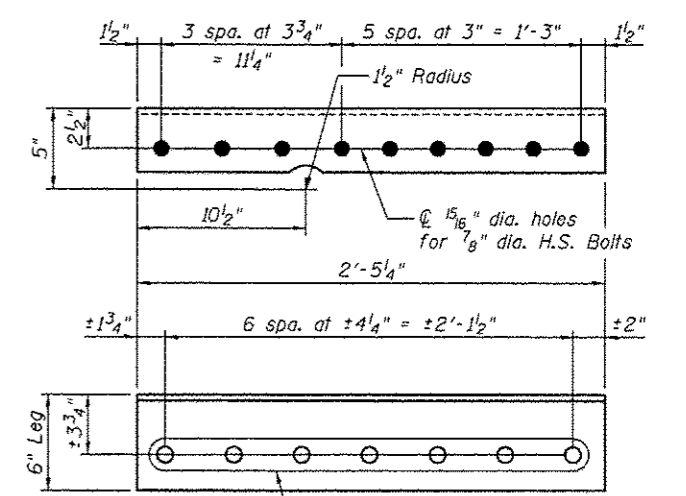

REPAIR ANGLE L6V
 L6 x 4 x 3/8 x 2'-5 1/4"

Notes:
 All bolted connections shown on this sheet shall be made with 1" dia. H.S. bolts unless otherwise noted.



USER NAME =	DESIGNED - MEL/YSS	REVISED
PLOT SCALE =	CHECKED - CDB	REVISED
PLOT DATE = 05/09/2014	DRAWN - AEC	REVISED
	CHECKED - MEL	REVISED

STATE OF ILLINOIS
 DEPARTMENT OF TRANSPORTATION

MAIN SPAN GUSSET PLATE STRENGTHENING - 4A
 S.N. 082-6001 MLK BRIDGE OVER MISSISSIPPI RIVER

SHEET NO. 549A OF 5138 SHEETS

F.A.P. RTE. 799	SECTION 1BR, DRS-2	COUNTY ST. CLAIR	TOTAL SHEETS 156	SHEET NO. 67A
			CONTRACT NO. 76B03	
ILLINOIS FED. AID PROJECT				

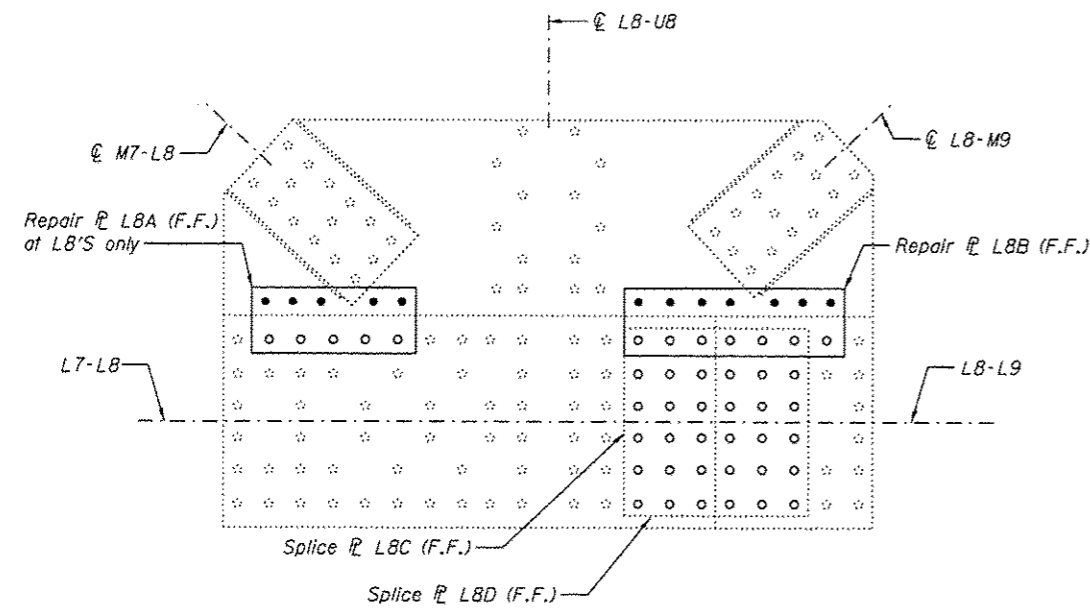

OUTSIDE PLATE AT PANEL POINT L8N AND L8S
(L8'N AND L8'S SIMILAR)
 (Span 9 and Span 11)

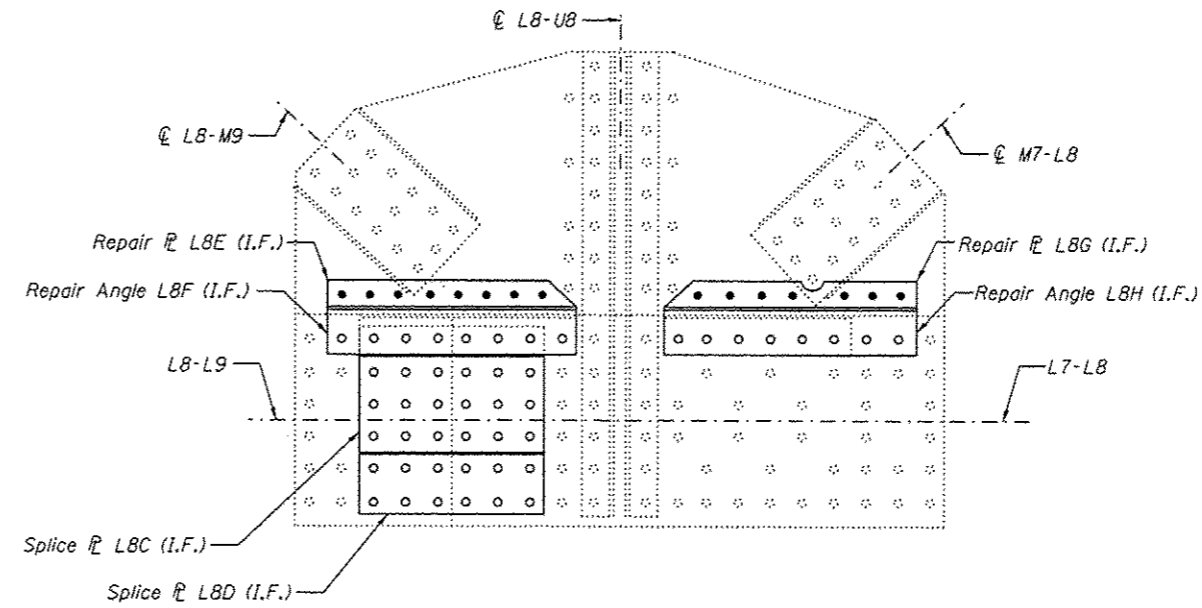

INSIDE PLATE AT PANEL POINT L8N AND L8S
(L8'N AND L8'S SIMILAR)
 (Span 9 and Span 11)

GUSSET PLATE STRENGTHENING

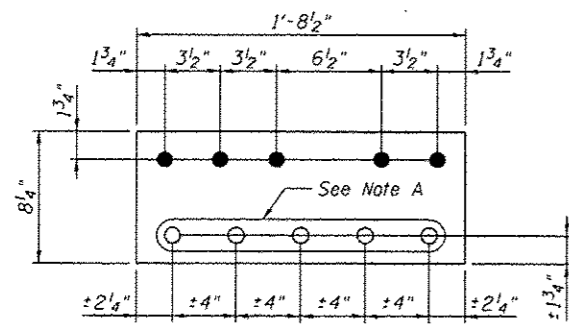

REPAIR P LBA
 P 5/8" X 8 1/4" X 1'-8 1/2"

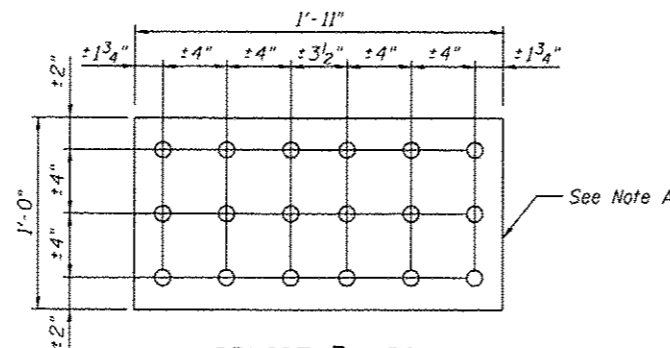

SPLICE P LBC
 P 5/8" X 1'-0" X 1'-11"

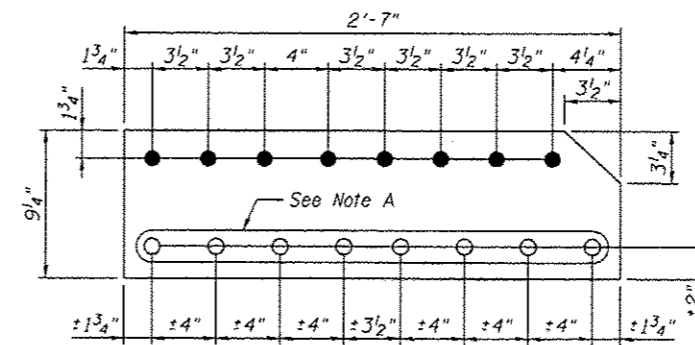

REPAIR P LBE
 P 5/8" X 9 1/4" X 2'-7"

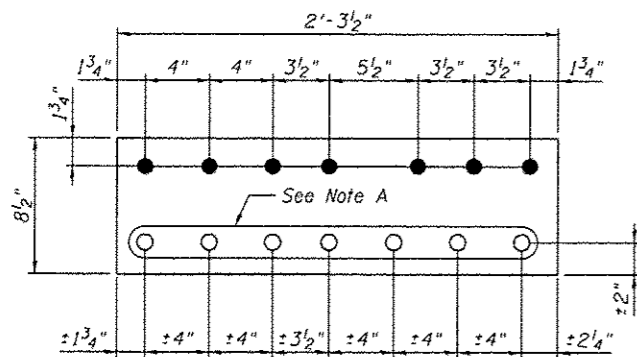

REPAIR P LBB
 P 5/8" X 8 1/2" X 2'-3 1/2"

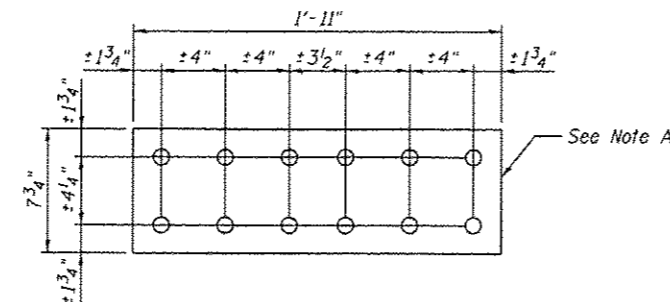

SPLICE P LBD
 P 5/8" X 7 3/4" X 1'-11"

Procedure
 Remove the bottom lateral connection plate and angle; then install repair plates and angles, as shown, one side at a time on the inside gusset plate. Install splice plate LBD on the inside gusset plate, followed by the installation of the splice plate LBC.

After completing the inside gusset plate strengthening, install the repair plates and splice plates, one at a time, on the outside gusset plate.

If additional fasteners need to be removed other than those shown on this sheet, the Contractor shall submit a procedure for review and approval. If needed, the Contractor shall provide temporary support for joints.

BILL OF MATERIAL

Item	Unit	Total
Structural Steel Repair	Pound	2840

Notes:
 All bolted connections shown on this sheet shall be made with 1" dia. H.S. bolts unless otherwise noted.
 For details of pieces LBF, LBG and LBH, see sheet S50A.
 For front and inside faces of gusset plate, see sheet S8.

Note A:
 Field drill holes using existing holes as template. Remainder of holes may be shop or field drilled.



USER NAME =	DESIGNED - MEL / YSS	REVISED
PLOT SCALE =	CHECKED - CDB	REVISED
PLOT DATE = 05/08/2014	DRAWN - AEC	REVISED
	CHECKED - MEL	REVISED

STATE OF ILLINOIS
DEPARTMENT OF TRANSPORTATION

MAIN SPAN GUSSET PLATE STRENGTHENING - 5
S.N. 082-6001 MLK BRIDGE OVER MISSISSIPPI RIVER

SHEET NO. 550 OF 5138 SHEETS

F.A.P. RTE. 799	SECTION 1BR, DRS-2	COUNTY ST. CLAIR	TOTAL SHEETS 156	SHEET NO. 68
CONTRACT NO. 76B03				ILLINOIS FED. AID PROJECT

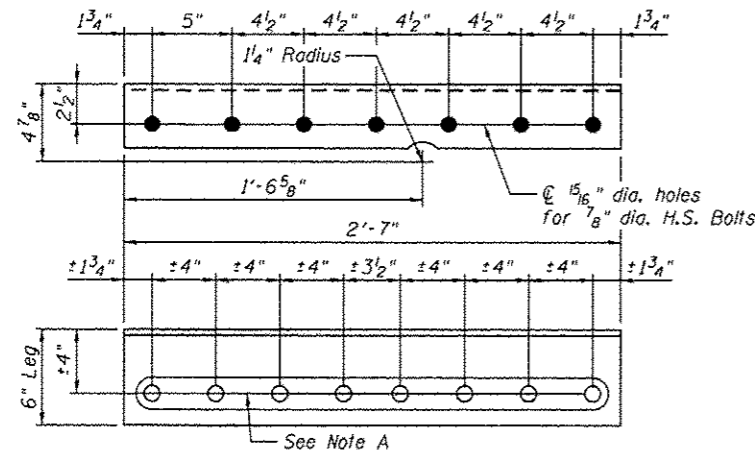

REPAIR ANGLE LBF

L6 x 4 x 3/8 x 2'-7"

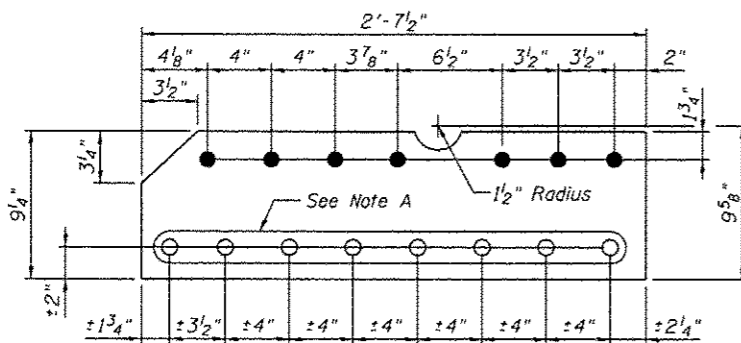

REPAIR PLB G

L 5/8" x 9/4" x 2'-7 1/2"

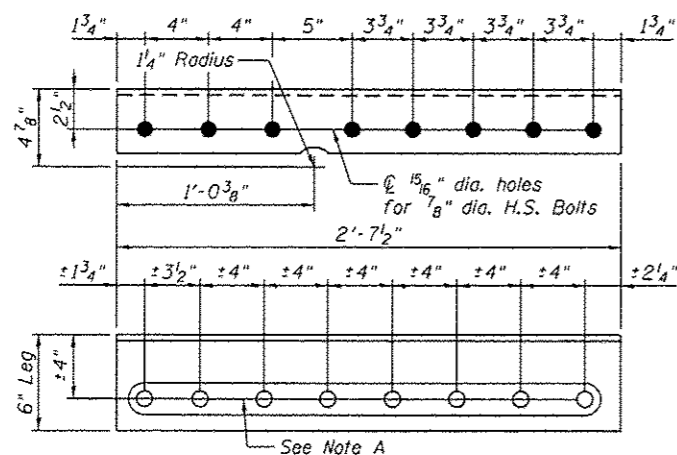

REPAIR ANGLE L8H

L6 x 4 x 3/8 x 2'-7 1/2"

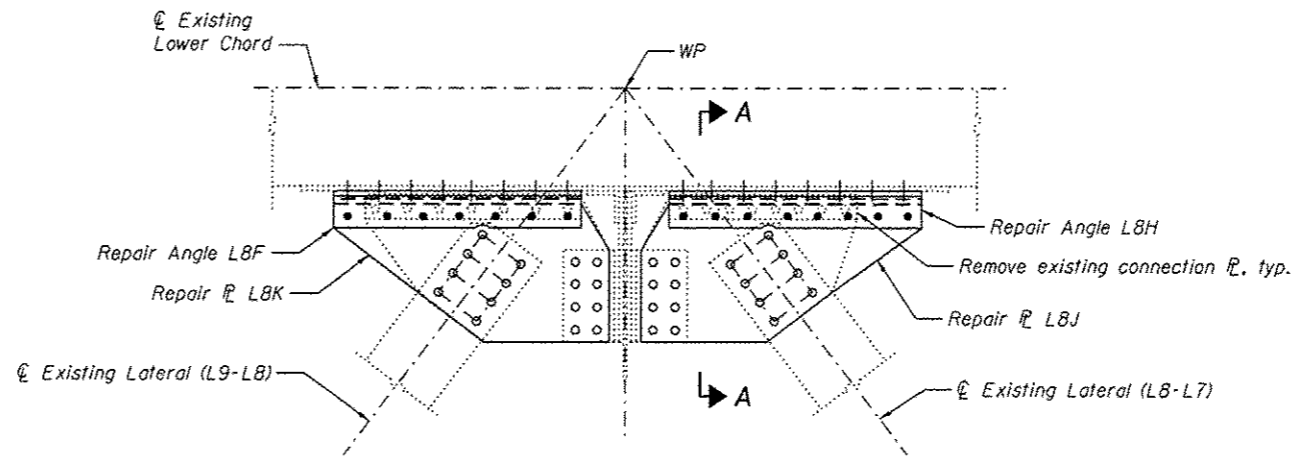

LOWER LATERAL AT PANEL POINT LBN AND LBS

(L8'N AND L8'S SIMILAR)

(Span 9 and Span 11)

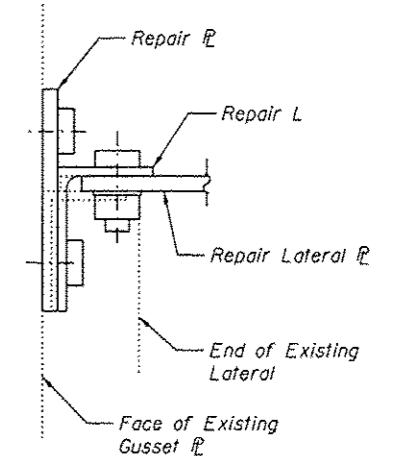

SECTION A-A

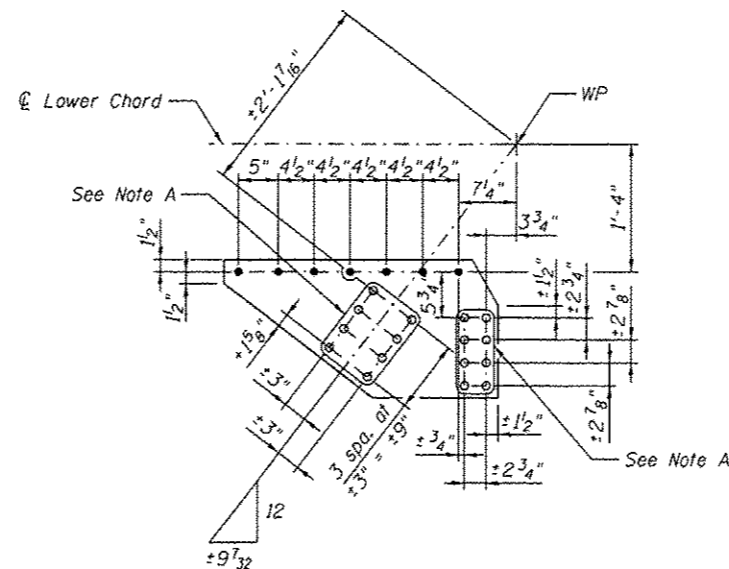

REPAIR PLB K

L 5/8" x 17 1/4" x 2'-10 1/4"

Note: Repair PLB K requires 15/16" φ holes for 7/8" φ H.S. bolts.

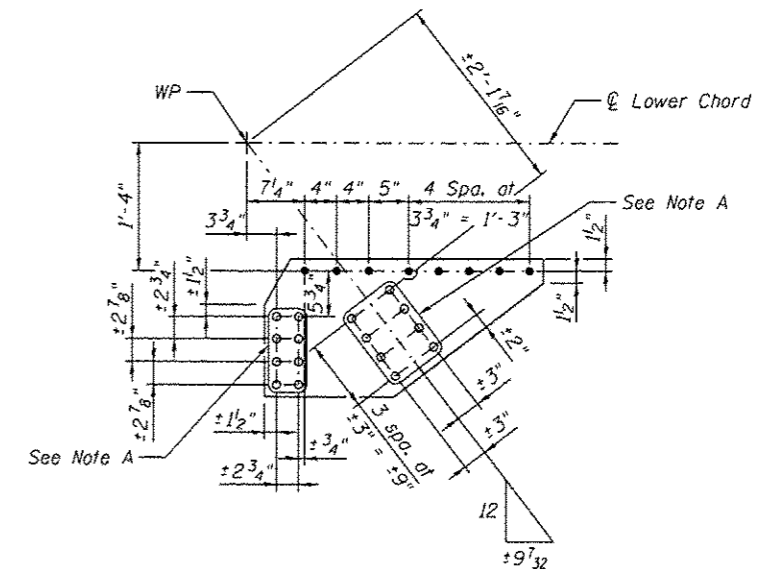

REPAIR PLB J

L 5/8" x 17 1/4" x 2'-10 3/4"

Note: Repair PLB J requires 15/16" φ holes for 7/8" φ H.S. bolts.

Note A:
Field drill holes using existing holes as template.
Remainder of holes may be shop or field drilled.

Notes:
All bolted connections shown on this sheet shall be made with 1" dia. H.S. bolts unless otherwise noted.
For locations of pieces L8F, L8G and L8H, see sheet S50.



USER NAME *	DESIGNED - MEL /YSS	REVISED
PLOT SCALE *	CHECKED - CDB	REVISED
PLOT DATE *	DRAWN - AEC	REVISED
	CHECKED - MEL	REVISED

STATE OF ILLINOIS
DEPARTMENT OF TRANSPORTATION

MAIN SPAN GUSSET PLATE STRENGTHENING - 5A
S.N. 082-6001 MLK BRIDGE OVER MISSISSIPPI RIVER

SHEET NO. S50A OF S138 SHEETS

F.A.P. RTE.	SECTION	COUNTY	TOTAL SHEETS	SHEET NO.
799	IBR, ORS-2	ST. CLAIR	156	68A
			CONTRACT NO. 76B03	
ILLINOIS FED. AID PROJECT				

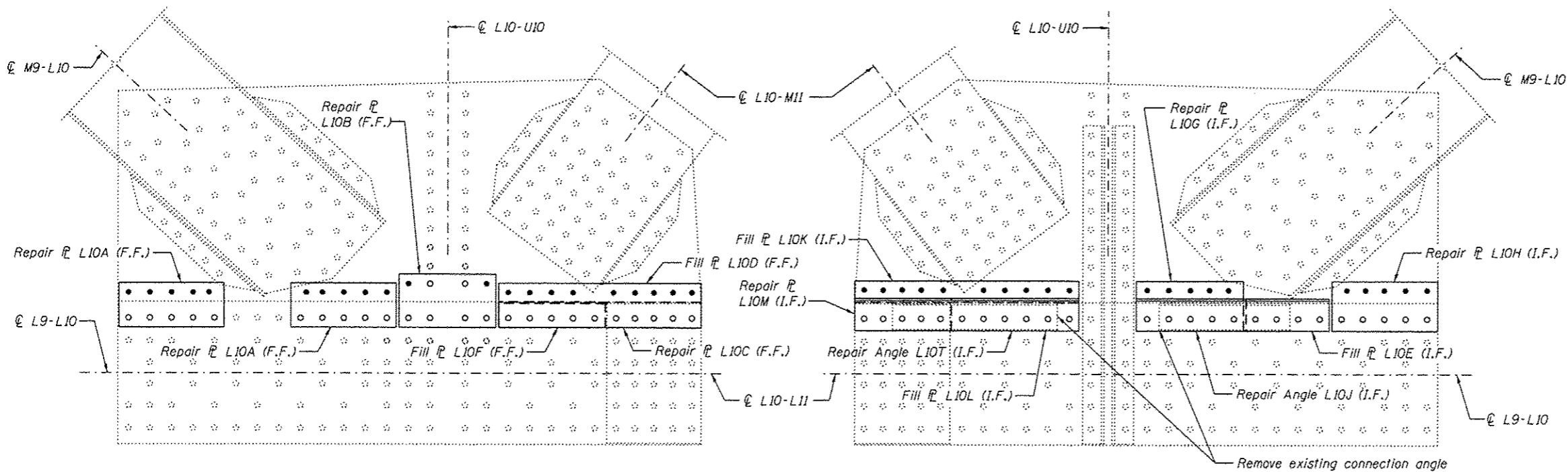

OUTSIDE PLATE AT PANEL POINT L10N AND L10S
 (L10'N AND L10'S SIMILAR)
 (Span 9 and Span 11)

INSIDE PLATE AT PANEL POINT L10N AND L10S
 (L10'N AND L10'S SIMILAR)
 (Span 9 and Span 11)

GUSSET PLATE STRENGTHENING

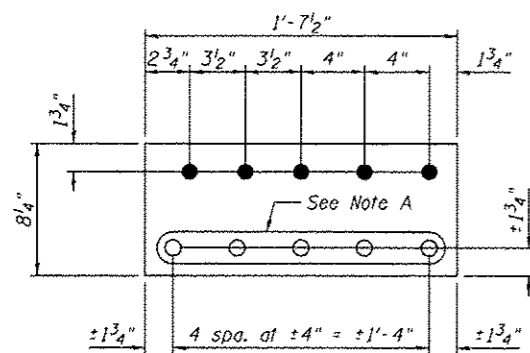

REPAIR P L10A
 P 7/8" x 8 1/4" x 1'-7 1/2"

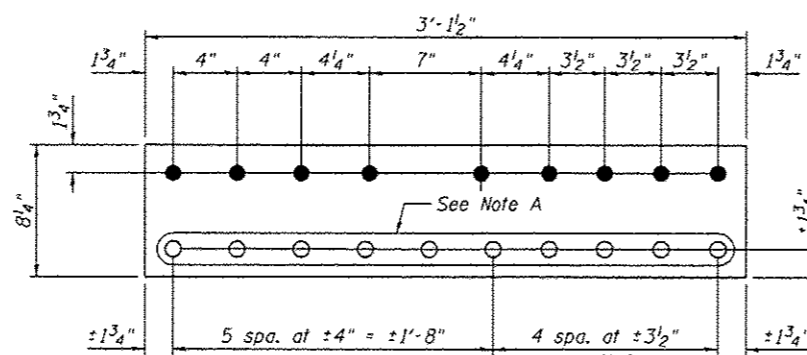

REPAIR P L10C
 P 7/8" x 8 1/4" x 3'-1 1/2"

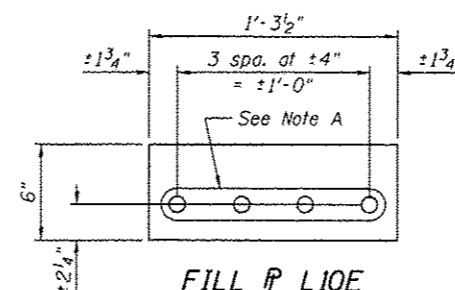

FILL P L10E
 P 7/8" x 6" x 1'-3 1/2"

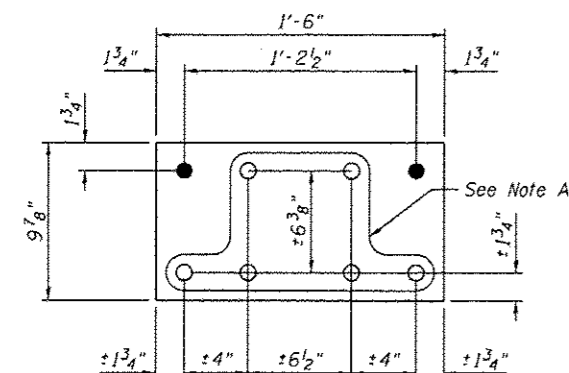

REPAIR P L10B
 P 7/8" x 9 7/8" x 1'-6"

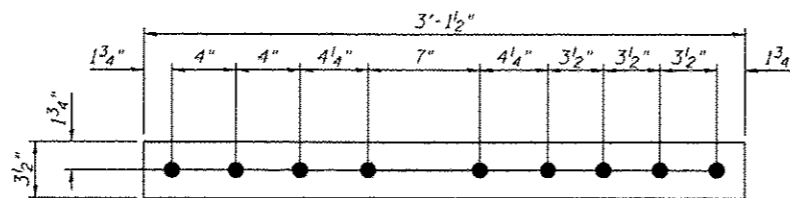

FILL P L10D
 P 9/16" x 3 1/2" x 3'-1 1/2"

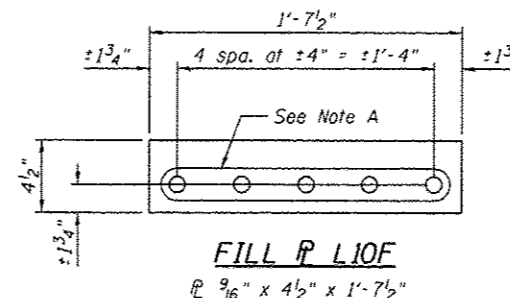

FILL P L10F
 P 9/16" x 4 1/2" x 1'-7 1/2"

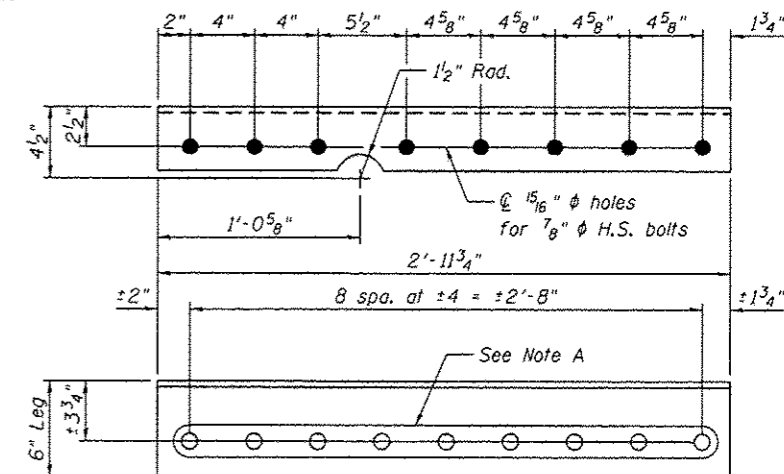

REPAIR P L10G
 P 7/8" x 9 1/4" x 1'-7 3/4"
REPAIR P L10H
 P 1 1/4" x 9 1/4" x 1'-7 3/4"

Procedure
 Remove the bottom lateral connection plate and angle; then install repair plates, angles and fills, as shown, one side at a time on the inside gusset plate. Install repair plate L10H on the inside gusset plate, followed by the installation of the repair plates, one at a time, on the outside gusset plate.
 If additional fasteners need to be removed other than those shown on this sheet, the Contractor shall submit a procedure for review and approval. If needed, the Contractor shall provide temporary support for joints.

REPAIR ANGLE L10J
 L6 x 4 x 3/8 x 2'-11 3/4"

BILL OF MATERIAL

Item	Unit	Total
Structural Steel Repair	Pound	3590

Notes:
 All bolted connections shown on this sheet shall be made with 1" dia. H.S. bolts unless otherwise noted.
 For details of pieces, L10K, L10L, L10M and L10T, see sheet S52.
 For front and inside faces of gusset plates, see sheet S8.



USER NAME :	DESIGNED - MEL /YSS	REVISED
PLOT SCALE :	CHECKED - COB	REVISED
PLOT DATE : 05/08/2014	DRAWN - AEC	REVISED
	CHECKED - MEL	REVISED

STATE OF ILLINOIS
 DEPARTMENT OF TRANSPORTATION

MAIN SPAN GUSSET PLATE STRENGTHENING - 6
 S.N. 082-6001 MLK BRIDGE OVER MISSISSIPPI RIVER

SHEET NO. S51 OF S138 SHEETS

F.A.P. RTE. 799	SECTION 1BR, DRS-2	COUNTY ST. CLAIR	TOTAL SHEETS 156	SHEET NO. 69
CONTRACT NO. 76B03			ILLINOIS FED. AID PROJECT	

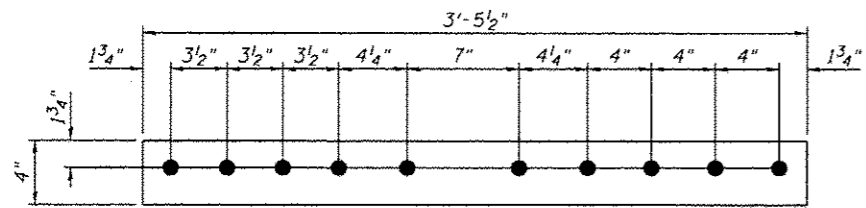

FILL PLATE L1OK
 $\frac{9}{16}$ " x 4" x 3'-5 1/2"

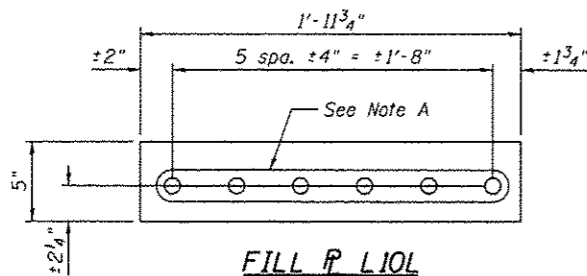

FILL PLATE L1OL
 $\frac{9}{16}$ " x 5" x 1'-11 3/4"

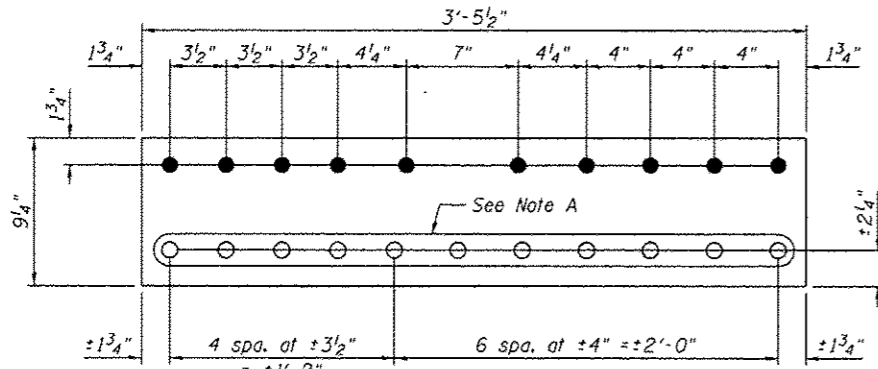

REPAIR PLATE L1OM
 $\frac{7}{8}$ " x 9 1/4" x 3'-5 1/2"

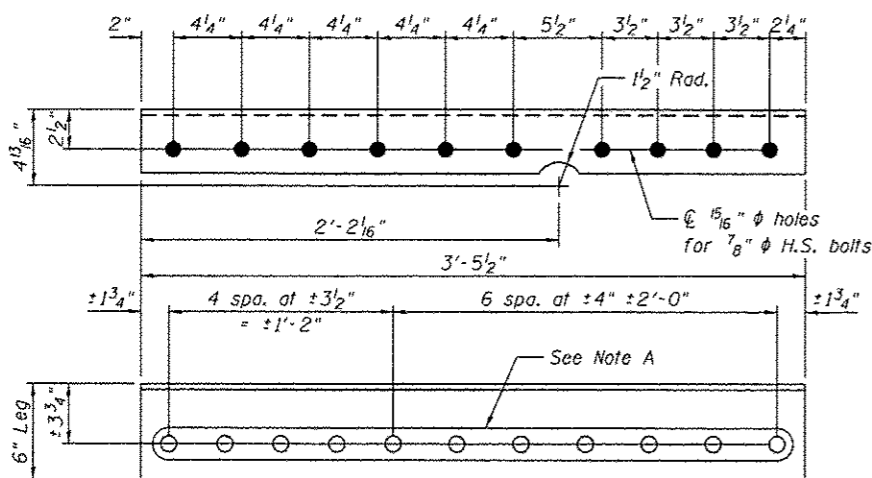

REPAIR ANGLE L1OT
 L6 x 4 x 3/8 x 3'-5 1/2"

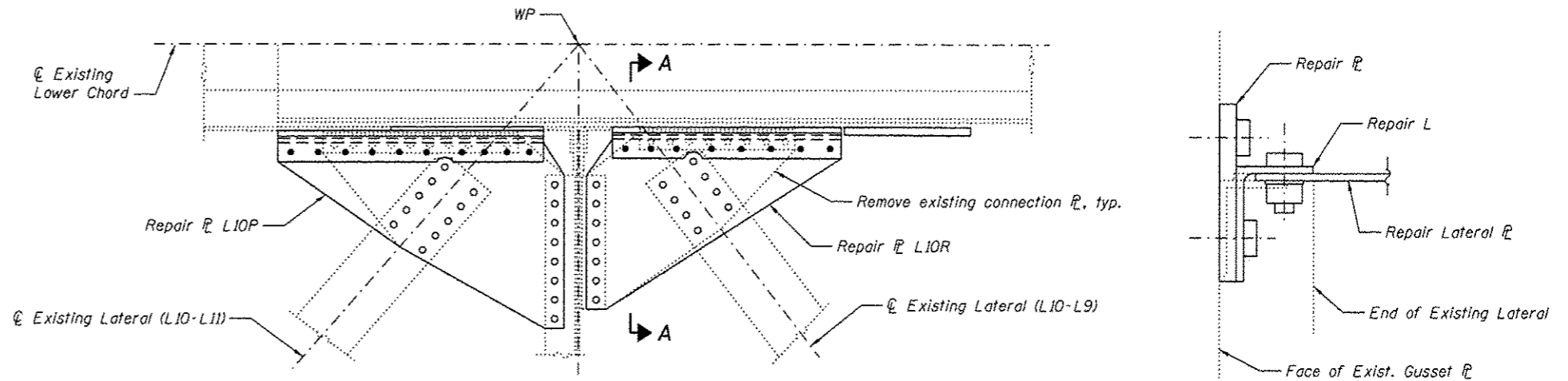

LOWER LATERAL AT PANEL POINT L10N AND L10S
 (L10N AND L10S SIMILAR)
 (Span 9 and Span 11)

SECTION A-A

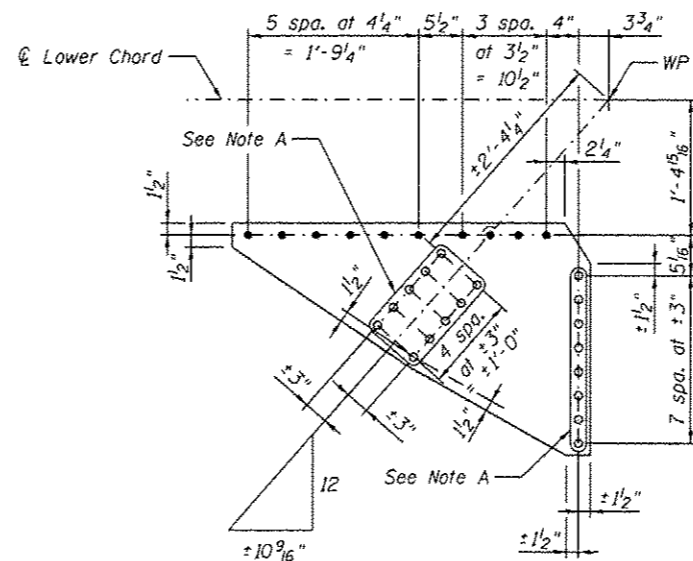

REPAIR PLATE L1OP
 $\frac{3}{8}$ " x 29 1/8" x 3'-8 3/4"

Note: Repair PL L1OP requires 15/16" holes for 7/8" H.S. bolts.

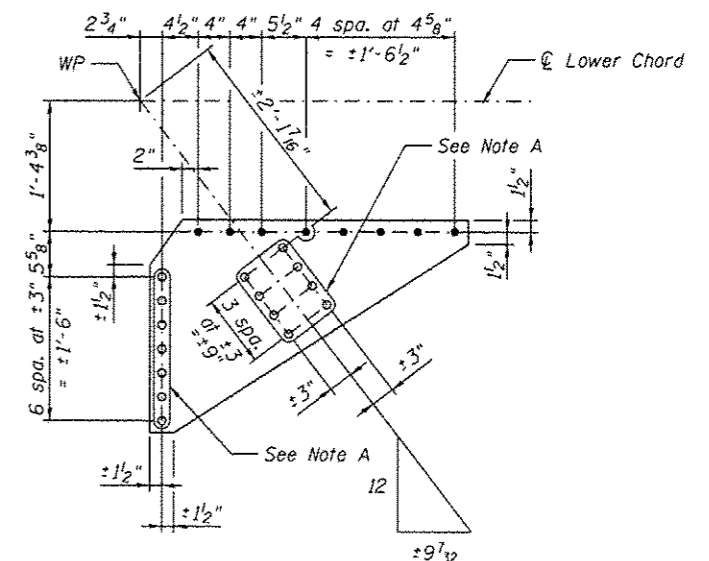

REPAIR PLATE L1OR
 $\frac{3}{8}$ " x 26 5/8" x 3'-3 3/4"

Note: Repair PL L1OR requires 15/16" holes for 7/8" H.S. bolts.

Note A:
 Field drill holes using existing holes as template.
 Remainder of holes may be shop or field drilled.

Notes:
 All bolted connections shown on this sheet shall be made with 1" dia. H.S. bolts unless otherwise noted.
 For location of pieces, L1OK, L1OL, L1OM and L1OT, see sheet S51.



USER NAME *	DESIGNED - MEL /YSS	REVISED
PLOT SCALE *	CHECKED - CDB	REVISED
PLOT DATE 05/09/2014	DRAWN - AEC	REVISED
	CHECKED - MEL	REVISED

STATE OF ILLINOIS
 DEPARTMENT OF TRANSPORTATION

MAIN SPAN GUSSET PLATE STRENGTHENING - 7
 S.N. 082-6001 MLK BRIDGE OVER MISSISSIPPI RIVER

SHEET NO. S52 OF S138 SHEETS

F.A.P. RTE. 799	SECTION IBR, DRS-2	COUNTY ST. CLAIR	TOTAL SHEETS 156	SHEET NO. 70
ILLINOIS FED. AID PROJECT			CONTRACT NO. 76803	

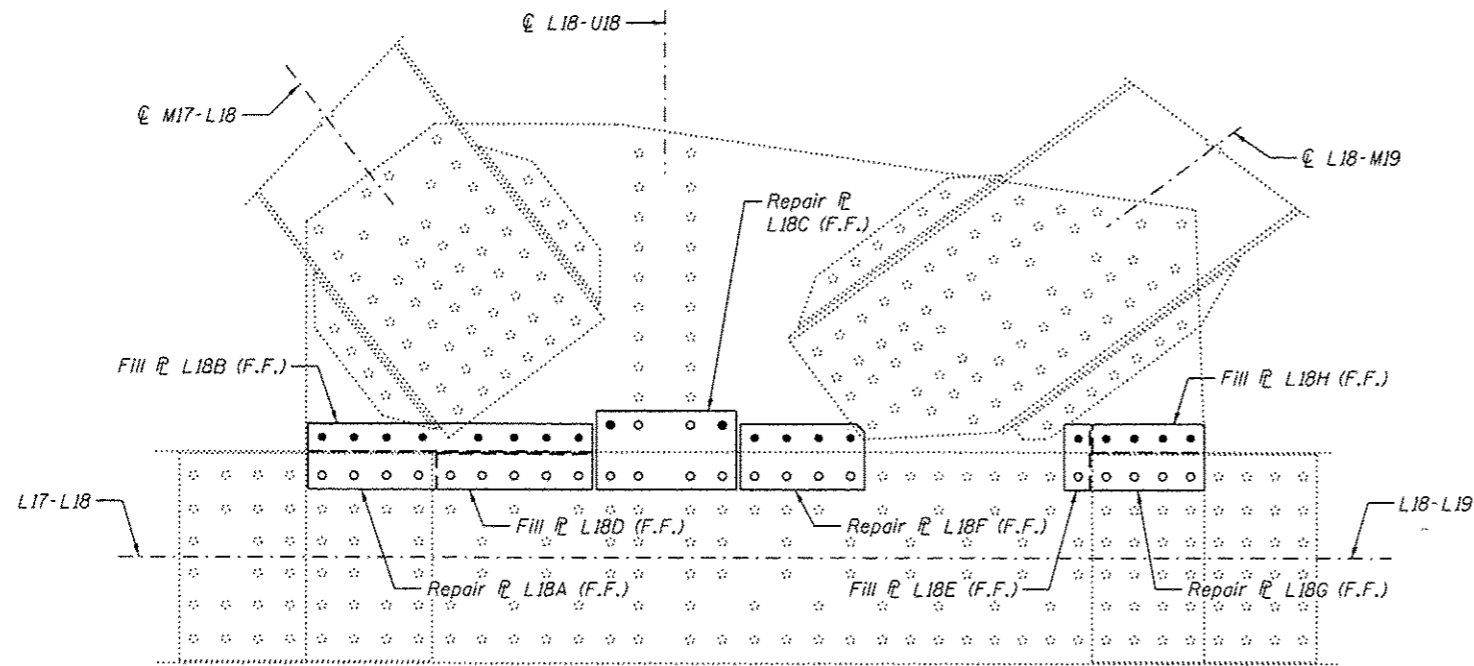

OUTSIDE PLATE AT PANEL POINT L18N AND L18S
 (L18'N AND L18'S SIMILAR)
 (Span 10)

GUSSET PLATE STRENGTHENING

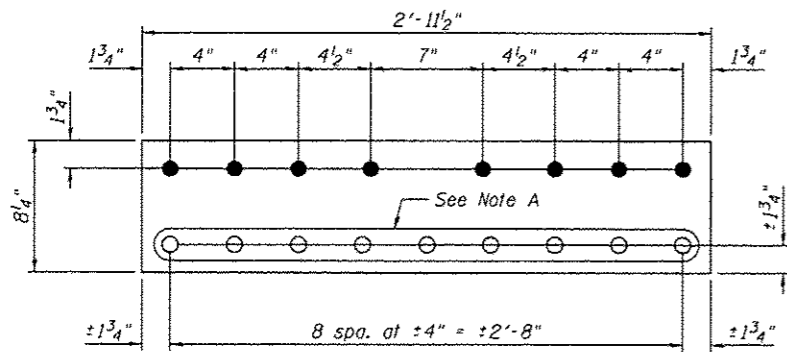

REPAIR P L18A
 @ 7/8" x 8 1/4" x 2'-11 1/2"

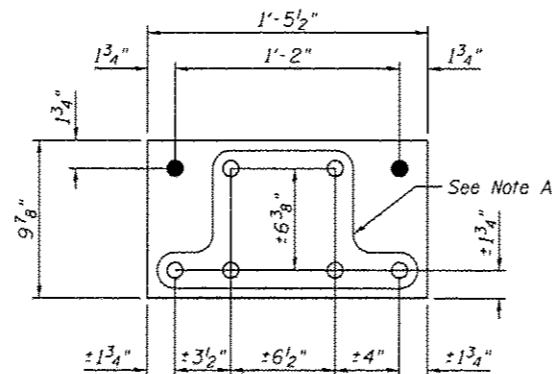

REPAIR P L18C
 @ 7/8" x 9 7/8" x 1'-5 1/2"

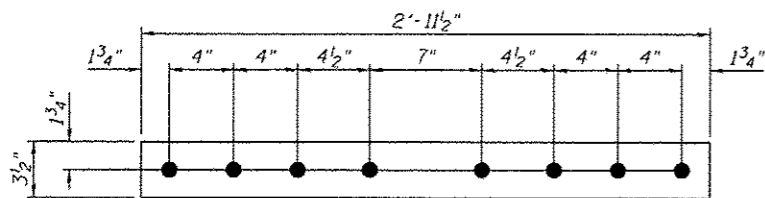

FILL P L18B
 @ 3/8" x 3 1/2" x 2'-11 1/2"

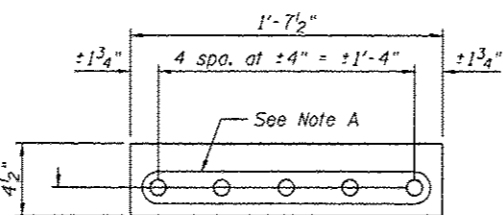

FILL P L18D
 @ 3/8" x 4 1/2" x 1'-7 1/2"

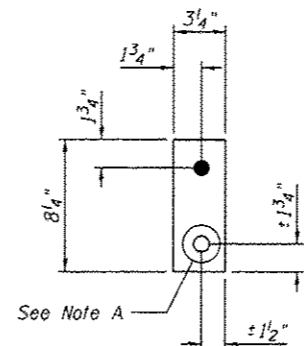

FILL P L18E
 @ 1/2" x 3 1/4" x 0'-8 1/4"

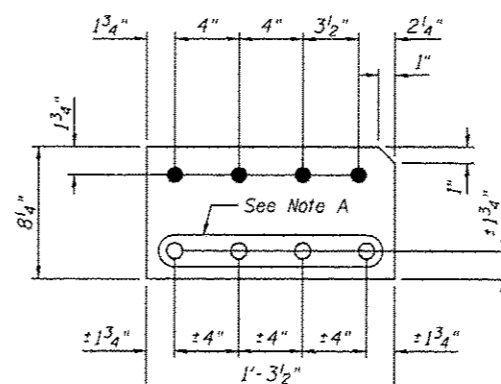

REPAIR P L18F
 @ 7/8" x 8 1/4" x 1'-3 1/2"

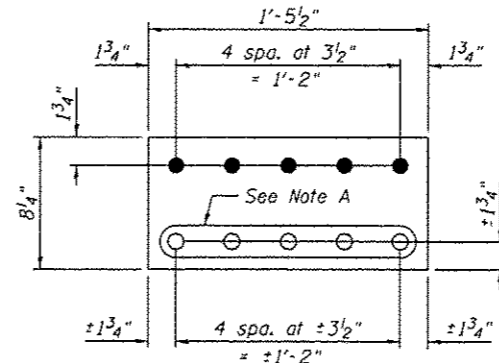

REPAIR P L18G
 @ 1/2" x 8 1/4" x 1'-5 1/2"

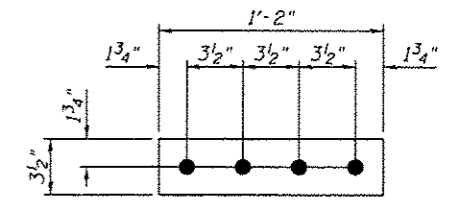

FILL P L18H
 @ 1/2" x 3 1/2" x 1'-2"

Note A:
 Field drill holes using existing holes as template.
 Remainder of holes may be shop or field drilled.

Procedure

Remove the bottom lateral connection plate and angle; then install repair plates, angles and fills, as shown, one side at a time on the inside gusset plate. Install repair plate L18G on the inside gusset plate, followed by the installation of the repair plates, one at a time, on the outside gusset plate.

If additional fasteners need to be removed other than those shown on this sheet, the Contractor shall submit a procedure for review and approval. If needed, the Contractor shall provide temporary support for joints.

BILL OF MATERIAL

Item	Unit	Total
Structural Steel Repair	Pound	3510

Notes:
 All bolted connections shown on this sheet shall be made with 1" dia. H.S. bolts unless otherwise noted.
 For L18 inside gusset @, see sheet S54.
 For front face of gusset plate, see sheet S8.



USER NAME =	DESIGNED - MEL / YSS	REVISED
	CHECKED - COB	REVISED
PLOT SCALE =	DRAWN - AEC	REVISED
PLOT DATE = 05/08/2014	CHECKED - MEL	REVISED

STATE OF ILLINOIS
 DEPARTMENT OF TRANSPORTATION

MAIN SPAN GUSSET PLATE STRENGTHENING - 8
 S.N. 082-6001 MLK BRIDGE OVER MISSISSIPPI RIVER

SHEET NO. S53 OF S138 SHEETS

F.A.P. RTE. 799	SECTION 1BR, DRS-2	COUNTY ST. CLAIR	TOTAL SHEETS 156	SHEET NO. 71
ILLINOIS FED. AID PROJECT			CONTRACT NO. 76803	

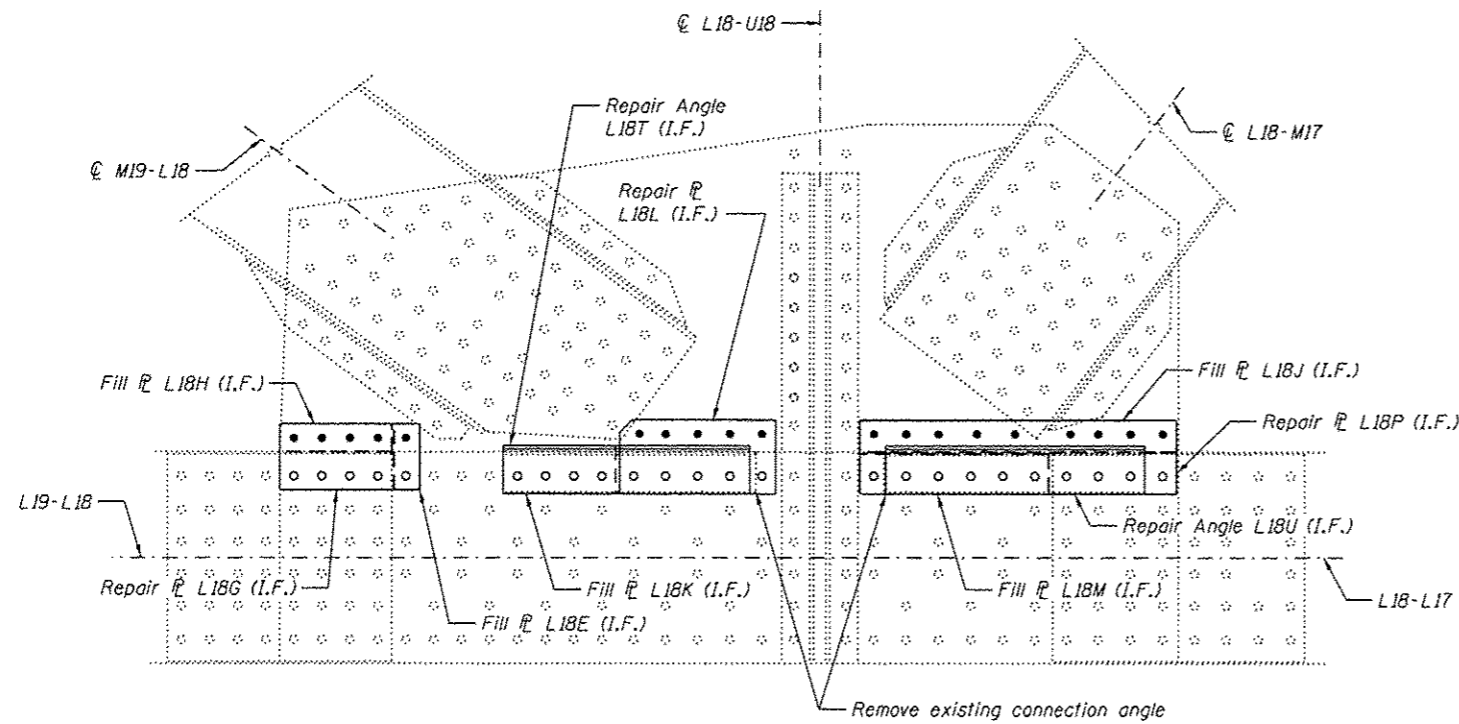

INSIDE PLATE AT PANEL POINT L18N AND L18S
 (L18'N AND L18'S SIMILAR)
 (Span 10)

GUSSET PLATE STRENGTHENING

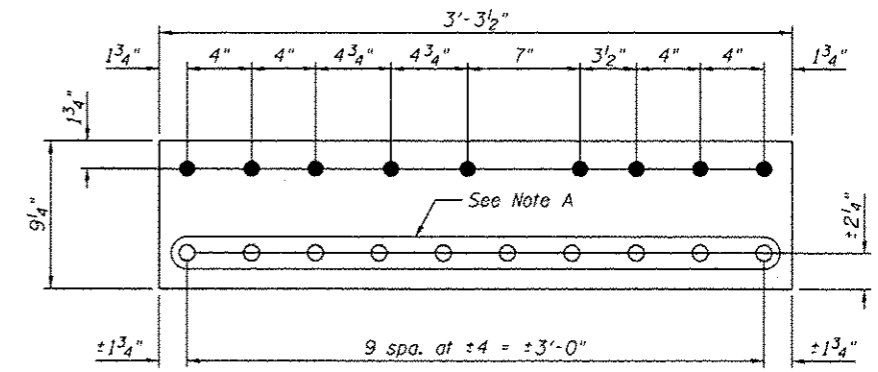

REPAIR P L18P
 P 7/8" x 9/4" x 3'-3 1/2"

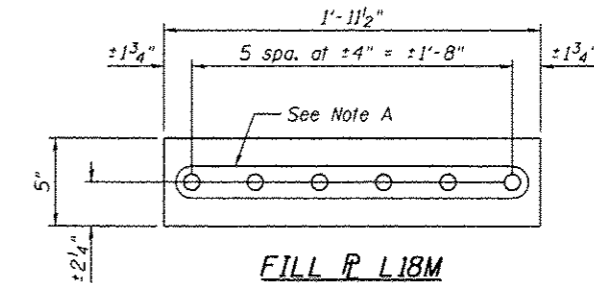

FILL P L18M
 P 3/8" x 5" x 1'-11 1/2"

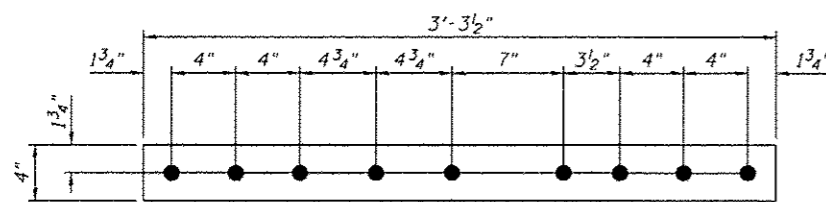

FILL P L18J
 P 3/8" x 4" x 3'-3 1/2"

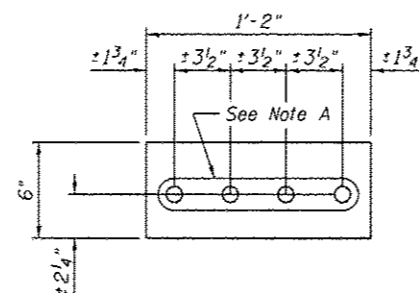

FILL P L18K
 P 7/8" x 6" x 1'-2"

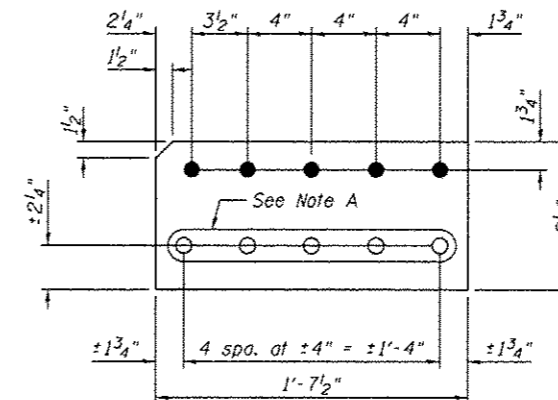

REPAIR P L18L
 P 7/8" x 9 1/4" x 1'-7 1/2"

Note A:
 Field drill holes using existing holes as template.
 Remainder of holes may be shop or field drilled.

Notes:
 For the Installation Procedure and Bill of Material, see sheet S53.
 For details of pieces, L18E, L18G and L18H, see sheet S53.
 For details of pieces, L18T and L18U, see sheet S54A.
 For location and details of lateral connection repair plates, see sheet S54A.
 All bolted connections shown on this sheet shall be made with 1" dia. H.S. bolts unless otherwise noted.
 For inside face of gusset plate, see sheet S8.



USER NAME =	DESIGNED - MEL	REVISIONS
PLOT SCALE =	CHECKED - COB	REVISIONS
PLOT DATE = 05/08/2014	DRAWN - AEC	REVISIONS
	CHECKED - MEL	REVISIONS

STATE OF ILLINOIS
 DEPARTMENT OF TRANSPORTATION

MAIN SPAN GUSSET PLATE STRENGTHENING - 9
 S.N. 082-6001 MLK BRIDGE OVER MISSISSIPPI RIVER

SHEET NO. S54 OF S138 SHEETS

F.A.P. RTE. 799	SECTION 1BR, ORS-2	COUNTY ST. CLAIR	TOTAL SHEETS 156	SHEET NO. 72
ILLINOIS FED. AID PROJECT			CONTRACT NO. 76B03	

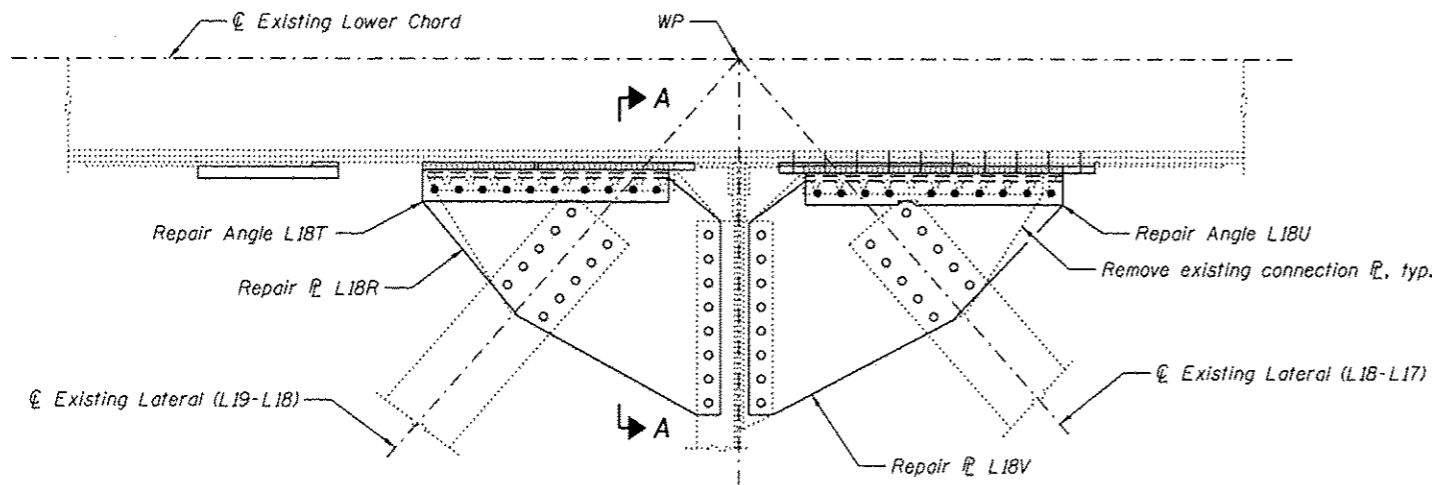

LOWER LATERAL AT PANEL POINT L18N AND L18S
(L18'N AND L18'S SIMILAR)
 (Span 10)

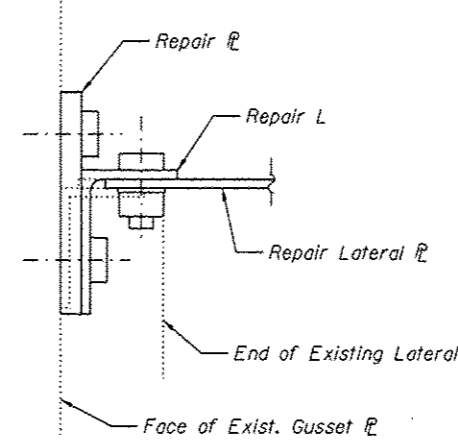

SECTION A-A

Note A:
 Field drill holes using existing holes as template.
 Remainder of holes may be shop or field drilled.

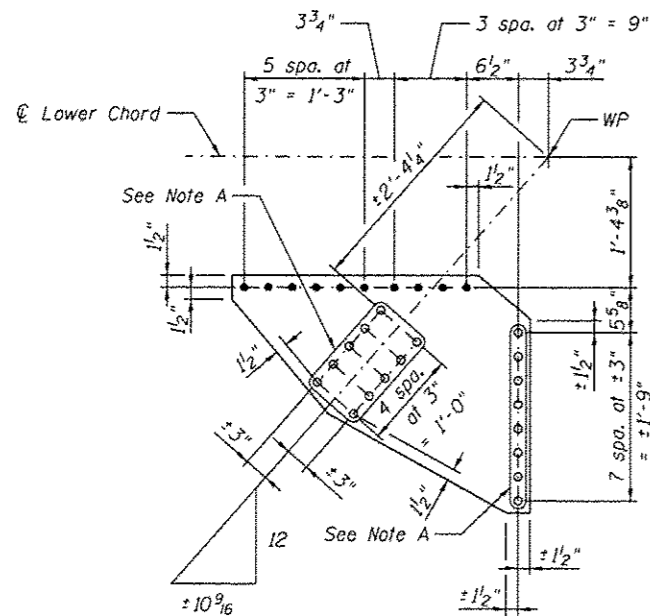

REPAIR L18R
 L 3/8" x 29 5/8" x 3'-1 1/4"

Note: Repair L18R requires
 15/16" φ holes for 7/8" φ H.S. bolts.

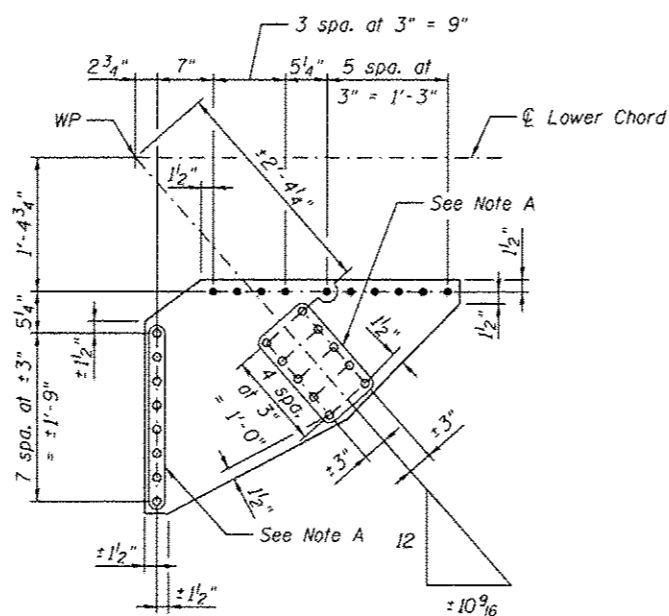

REPAIR L18V
 L 3/8" x 29 1/4" x 3'-3 3/4"

Note: Repair L18V requires
 15/16" φ holes for 7/8" φ H.S. bolts.

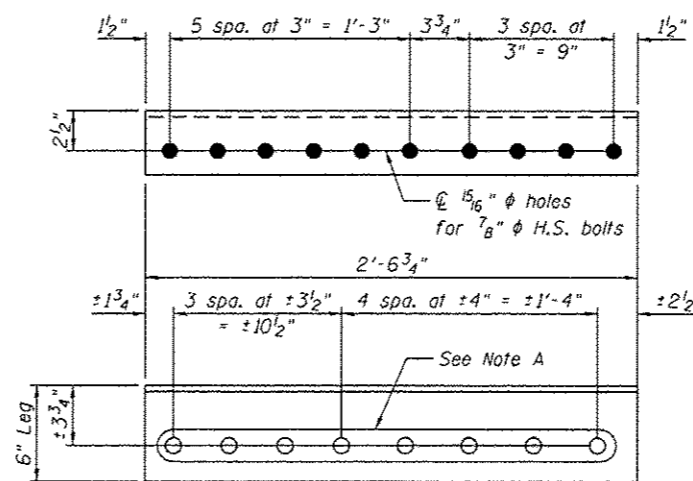

REPAIR ANGLE L18T
 L6 x 4 x 3/8 x 2'-6 3/4"

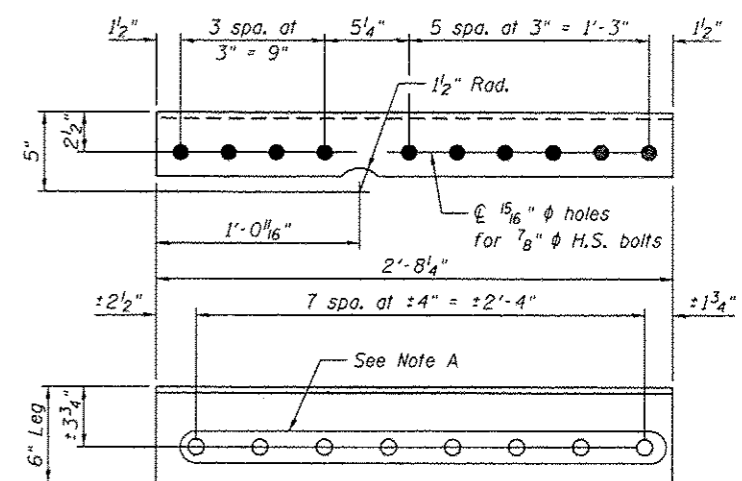

REPAIR ANGLE L18U
 L6 x 4 x 3/8 x 2'-8 1/4"

Notes:
 All bolted connections shown on this sheet shall be
 made with 1" dia. H.S. bolts unless otherwise noted.



USER NAME =	DESIGNED - MEL /YSS
PLOT SCALE =	CHECKED - CDB
PLOT DATE = 05/09/2014	DRAWN - AEC
	CHECKED - MEL

REVIS	REVIS
REVIS	REVIS
REVIS	REVIS
REVIS	REVIS

STATE OF ILLINOIS
 DEPARTMENT OF TRANSPORTATION

MAIN SPAN GUSSET PLATE STRENGTHENING - 9A
 S.N. 082-6001 MLK BRIDGE OVER MISSISSIPPI RIVER

SHEET NO. 554A OF 513B SHEETS

F.A.P. RTE. 799	SECTION 1BR, BR5-2	COUNTY ST. CLAIR	TOTAL SHEETS 156	SHEET NO. 72A
			CONTRACT NO. 76B03	
ILLINOIS FED. AID PROJECT				

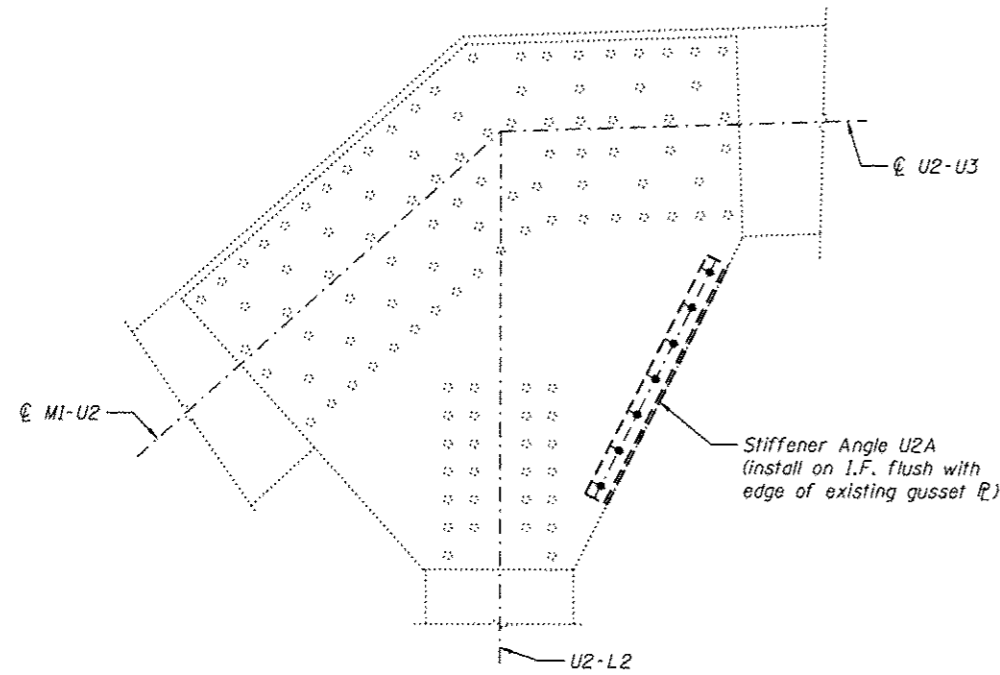

OUTSIDE PLATE AT PANEL POINT U2N AND U2S
 (U2'N AND U2'S SIMILAR)
 (Span 9 and 11)

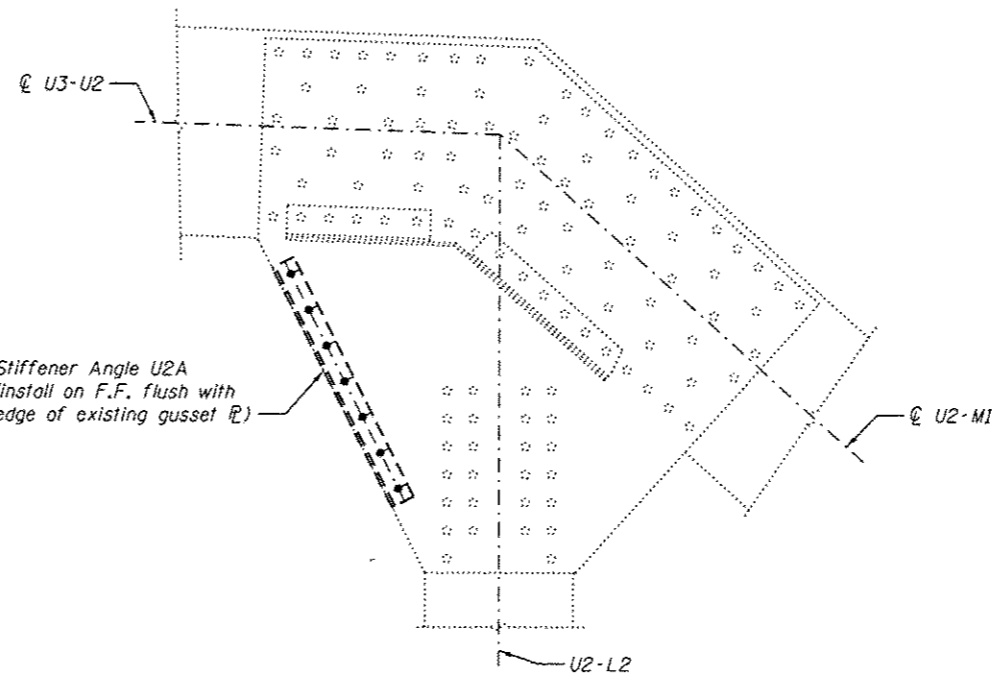

INSIDE PLATE AT PANEL POINT U2N AND U2S
 (U2'N AND U2'S SIMILAR)
 (Span 9 and 11)

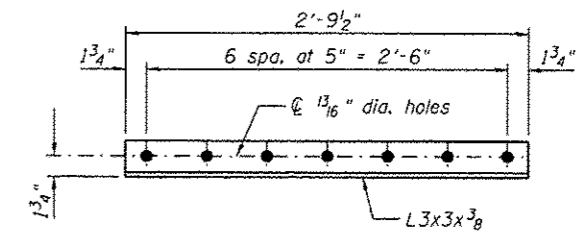

STIFFENER ANGLE U2A

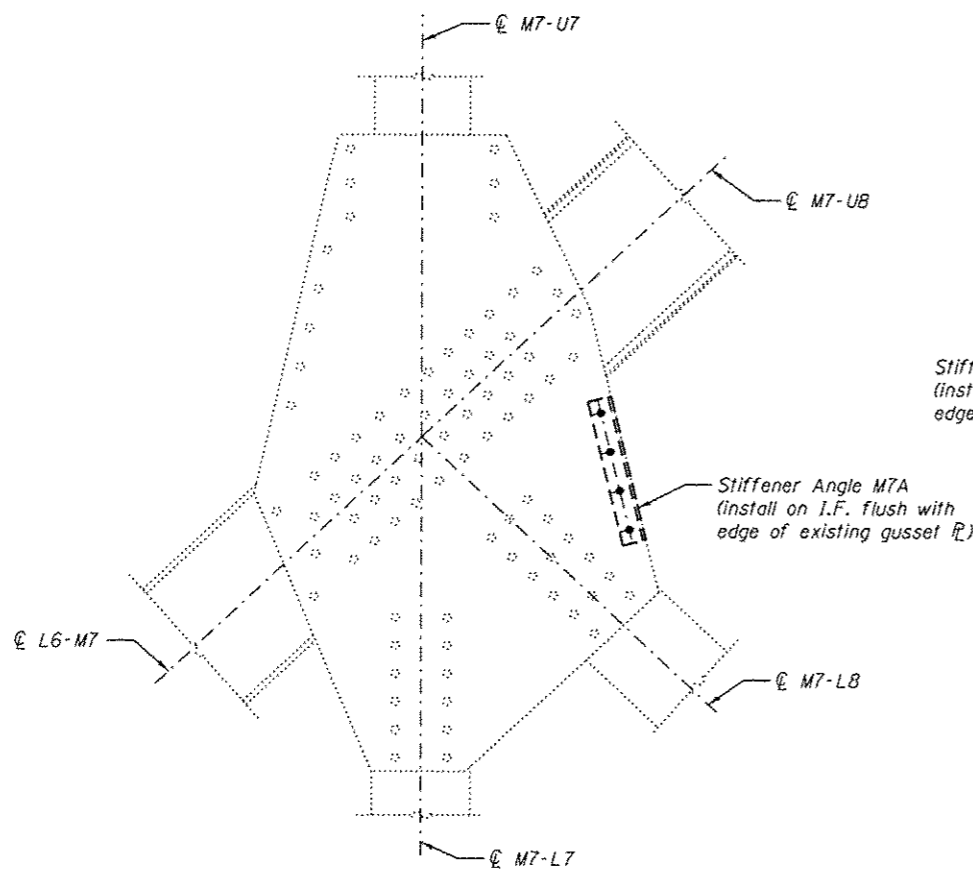

OUTSIDE PLATE AT PANEL POINT M7N AND M7S
 (M7'N AND M7'S SIMILAR)
 (Span 9 and 11)

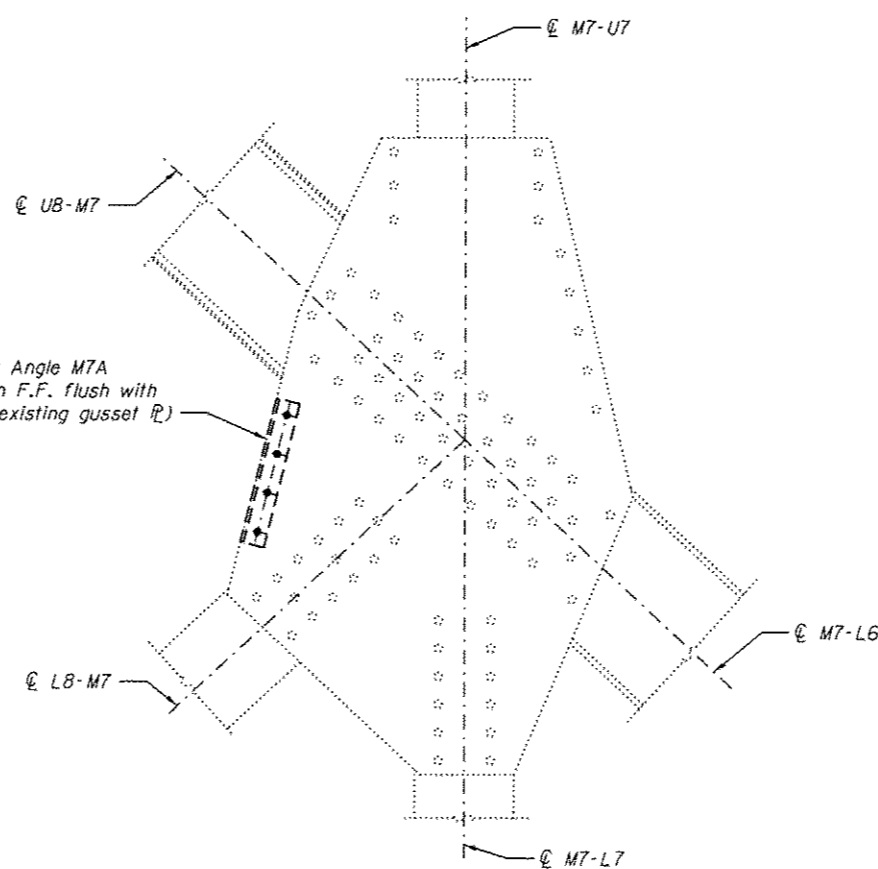

INSIDE PLATE AT PANEL POINT M7N AND M7S
 (M7'N AND M7'S SIMILAR)
 (Span 9 and 11)

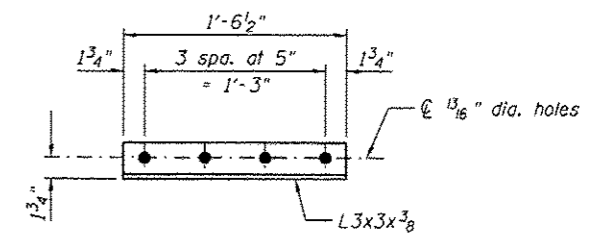

STIFFENER ANGLE M7A

Notes:
 Field drill holes in existing gusset plate using new material as template.
 All bolted connections shown on this sheet shall be made with 3/4" dia. H.S. bolts unless otherwise noted.

BILL OF MATERIAL

Item	Unit	Total
Structural Steel Repair	Pound	300

GUSSET PLATE STRENGTHENING



USER NAME =	DESIGNED - MEL	REVISED
	CHECKED - CDB	REVISED
PLOT SCALE =	DRAWN - PRC	REVISED
PLOT DATE = 05/02/2014	CHECKED - MEL	REVISED

STATE OF ILLINOIS
 DEPARTMENT OF TRANSPORTATION

MAIN SPANS GUSSET PLATE STRENGTHENING - 10
 S.N. 082-6001 MLK BRIDGE OVER MISSISSIPPI RIVER

SHEET NO. 555 OF 5138 SHEETS

F.A.P. RTE. 799	SECTION 1BR, DRS-2	COUNTY ST. CLAIR	TOTAL SHEETS 156	SHEET NO. 73
[ILLINOIS] FED. AID PROJECT			CONTRACT NO. 76B03	

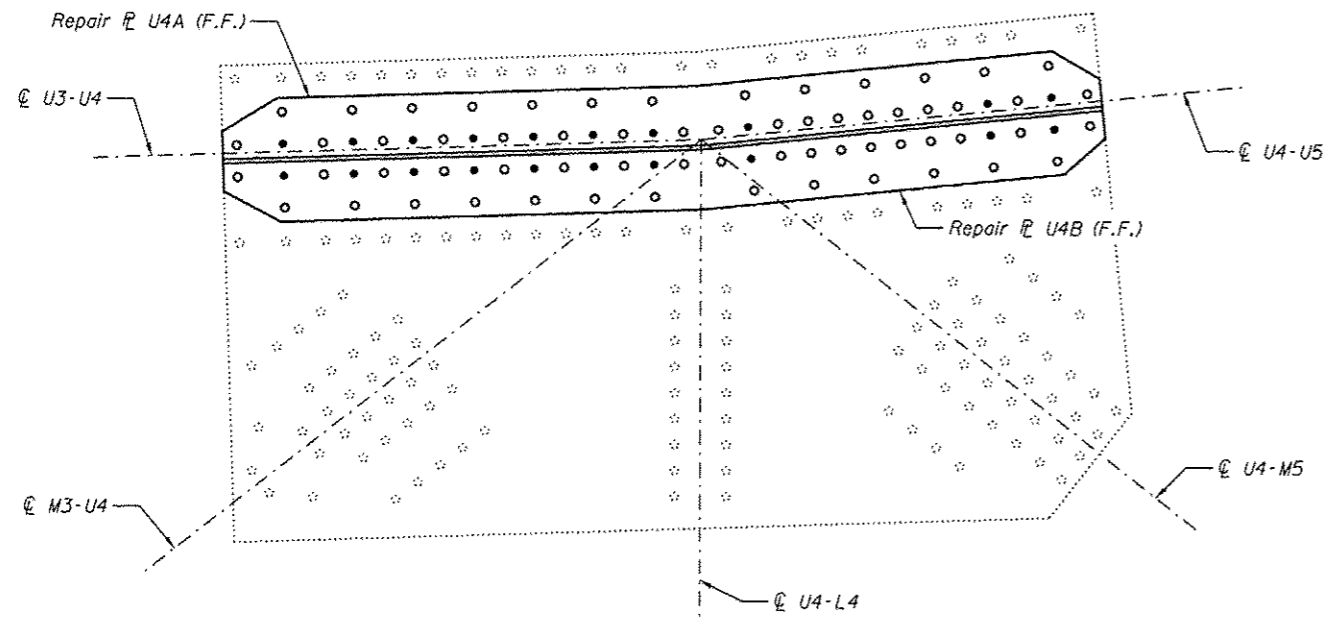

OUTSIDE PLATE AT PANEL POINT U4N AND U4S
 (U4'N AND U4'S SIMILAR)
 (Span 9 and 11)

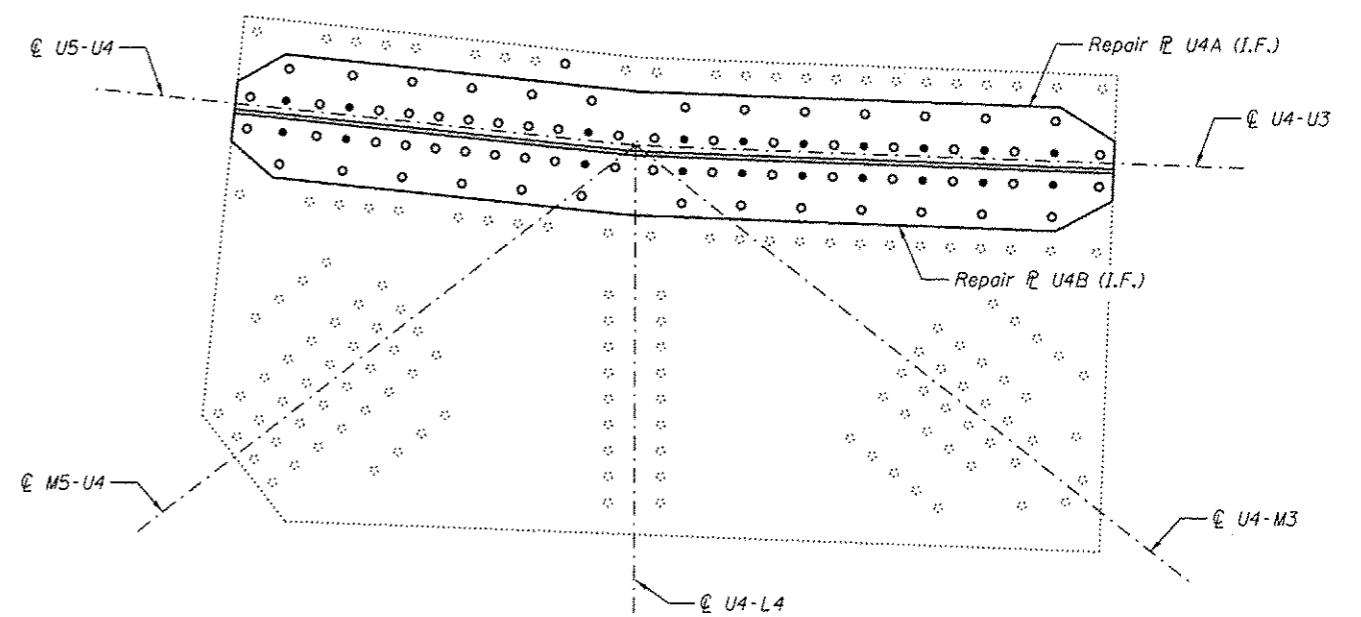

INSIDE PLATE AT PANEL POINT U4N AND U4S
 (U4'N AND U4'S SIMILAR)
 (Span 9 and 11)

GUSSET PLATE STRENGTHENING

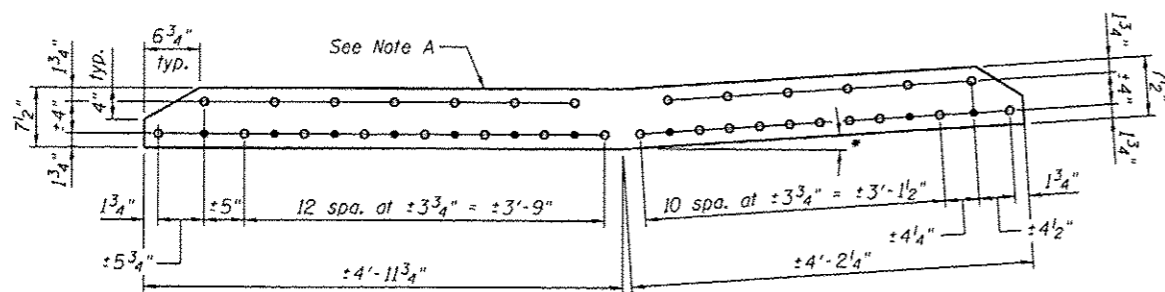

REPAIR P U4A
 P 5/8" x 7 1/2" x ±9'-2"

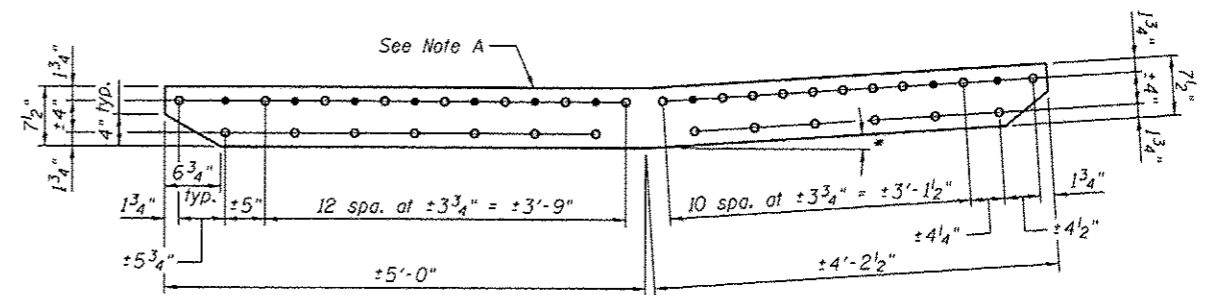

REPAIR P U4B
 P 5/8" x 7 1/2" x ±9'-2 1/2"

* To be determined in field

Note A:
 Field drill holes (○) using existing holes as template.
 Remainder of holes (●) may be shop or field drilled.

Procedure:
 On the Outside face of the Outside Gusset Plate:
 Install Repair Plate U4A with 1" Dia. A325 H.S. Bolts.
 After Repair Plate U4A is installed, install Repair Plate U4B with 1" Dia. A325 H.S. Bolts.
 Repeat for the Inside Gusset Plate.

BILL OF MATERIAL

Item	Unit	Total
Structural Steel Repair	Pound	3,080

Note:
 All bolted connections shown on this sheet shall be made with 1" dia. H.S. bolts unless otherwise noted.
 For front and inside faces of gusset plates, see truss cross section on sheet S8.

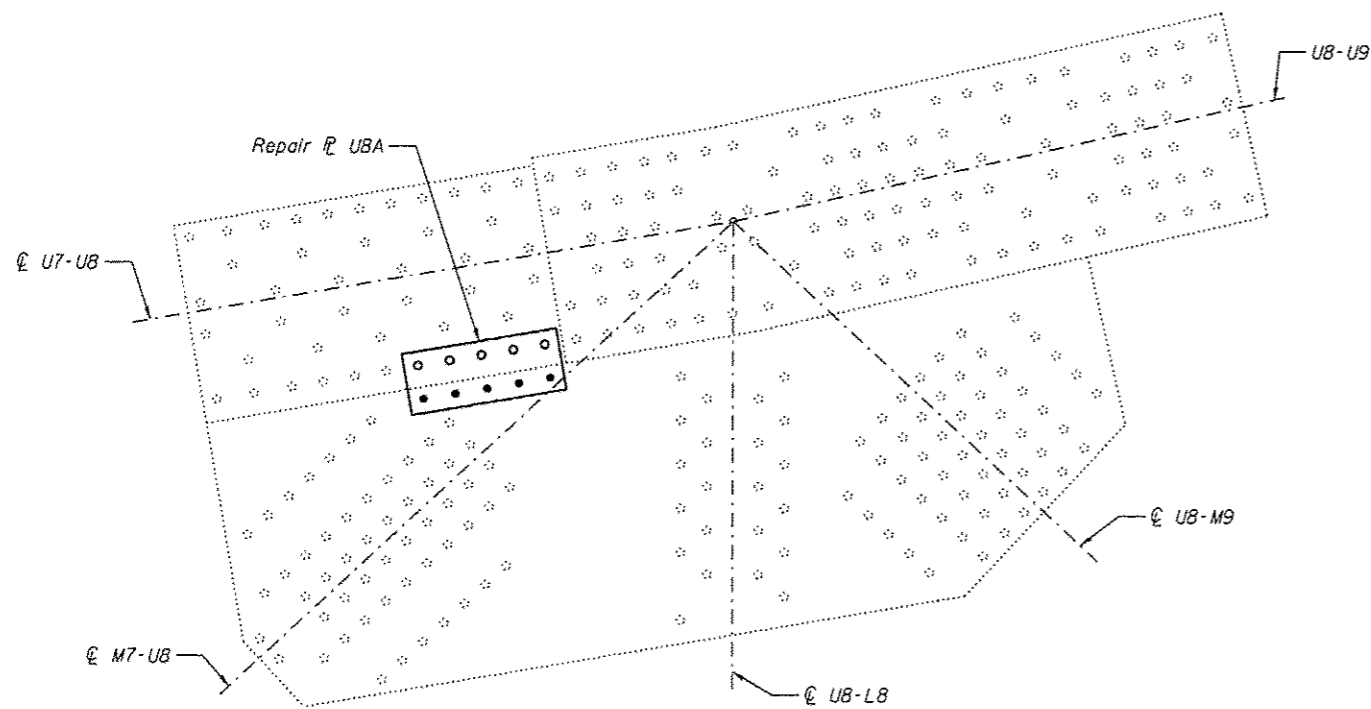

OUTSIDE PLATE AT PANEL POINT UB8N AND UB8S
(UB'N AND UB'S SIMILAR)
 (Span 9 and 11)

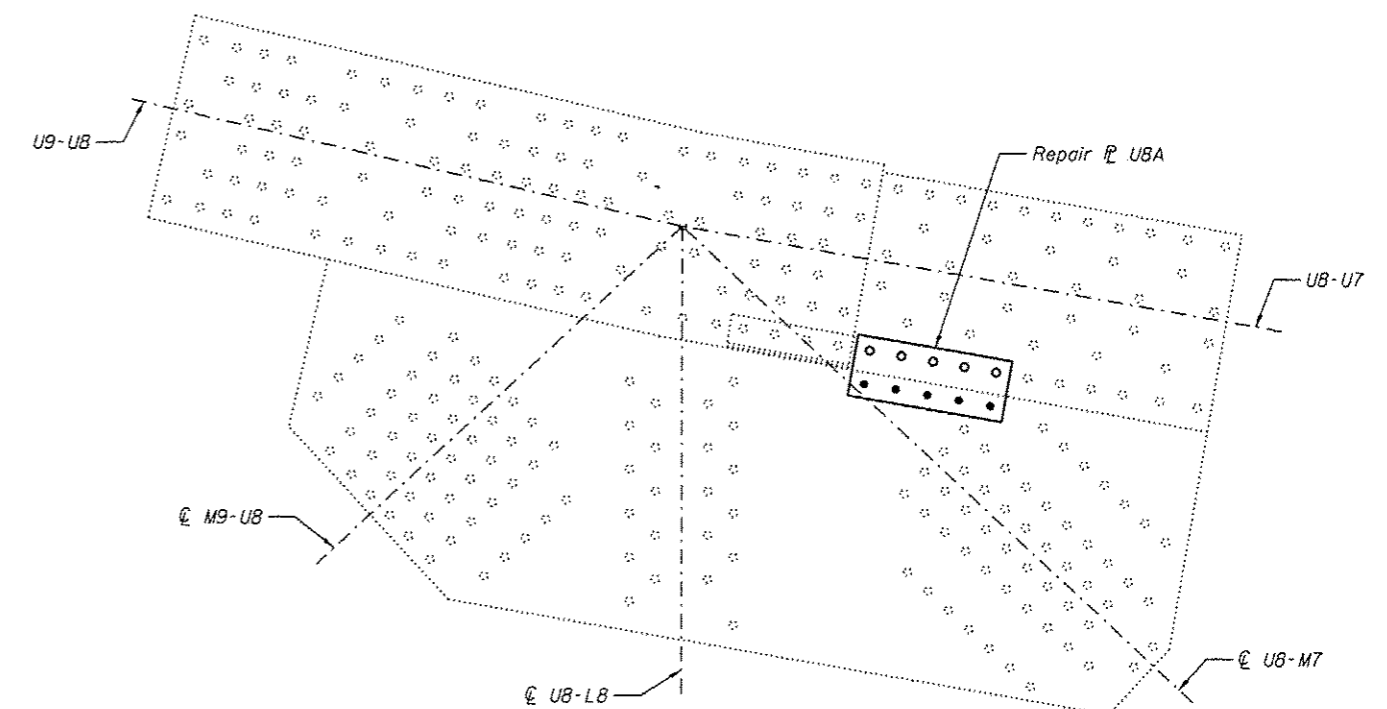

INSIDE PLATE AT PANEL POINT UB8N AND UB8S
(UB'N AND UB'S SIMILAR)
 (Span 9 and 11)

GUSSET PLATE STRENGTHENING

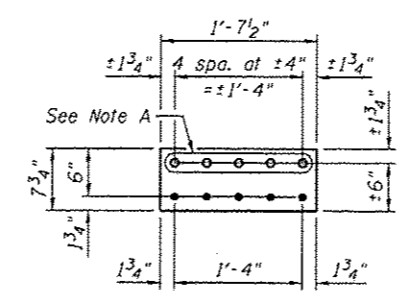

REPAIR P UBA
 P 3/4" x 7 3/4" x 1'-7 1/2"

Note A:
 Field drill holes using existing holes as template.
 Remainder of holes may be shop or field drilled.

Procedure:
 Install repair plates one at a time.

BILL OF MATERIAL

Item	Unit	Total
Structural Steel Repair	Pound	360

Note:
 All bolted connections shown on this sheet shall be made with 1" dia. H.S. bolts unless otherwise noted.



USER NAME :	DESIGNED - MEL	REVISED
	CHECKED - CDB	REVISED
PLOT SCALE :	DRAWN - PRC	REVISED
PLOT DATE : 05/02/2014	CHECKED - MEL	REVISED

STATE OF ILLINOIS
DEPARTMENT OF TRANSPORTATION

MAIN SPANS GUSSET PLATE STRENGTHENING - 12
S.N. 082-6001 MLK BRIDGE OVER MISSISSIPPI RIVER

SHEET NO. S57 OF S138 SHEETS

F.A.P. RTE.	SECTION	COUNTY	TOTAL SHEETS	SHEET NO.
799	1BR, DRS-2	ST. CLAIR	156	75
			CONTRACT NO. 76B03	
ILLINOIS FED. AID PROJECT				

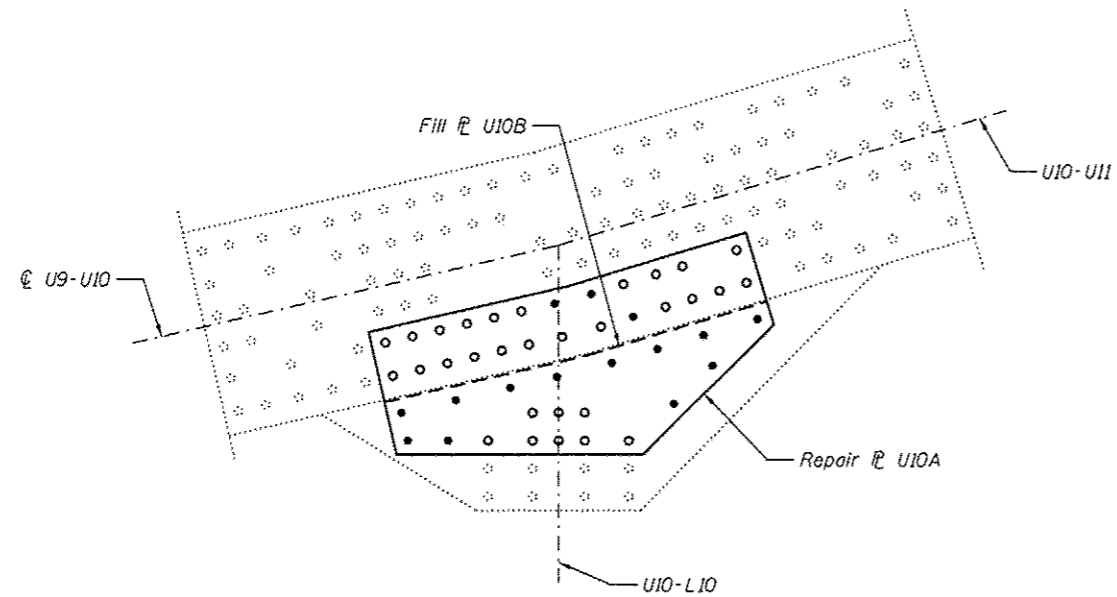

OUTSIDE PLATE AT PANEL POINT U10N AND U10S
 (U10'N AND U10'S SIMILAR)
 (Span 9 and 11)

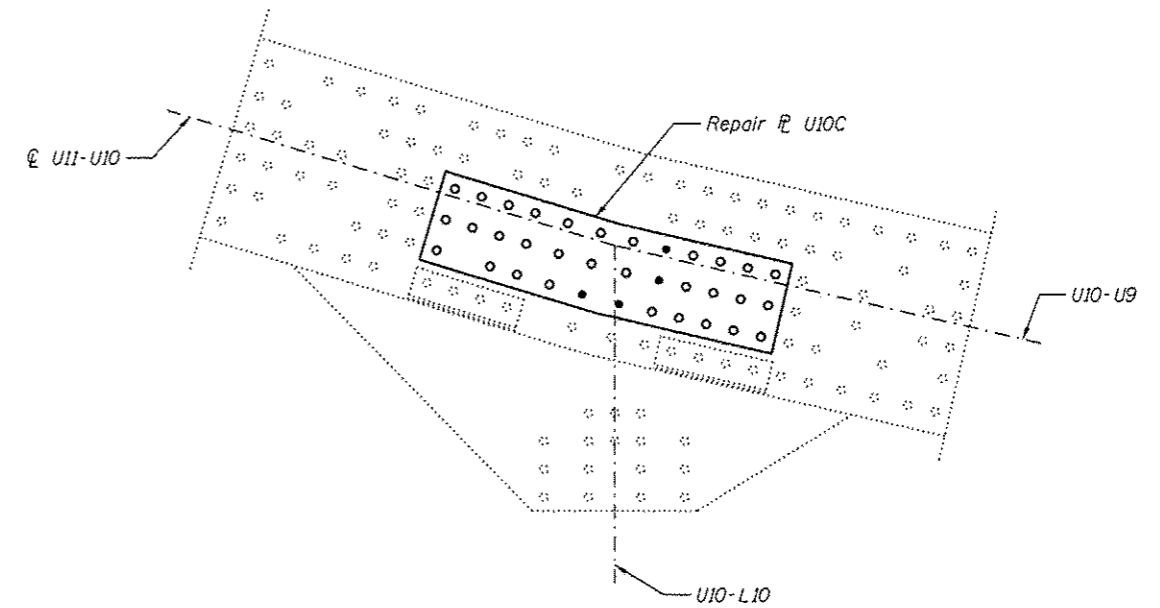

INSIDE PLATE AT PANEL POINT U10N AND U10S
 (U10'N AND U10'S SIMILAR)
 (Span 9 and 11)

GUSSET PLATE STRENGTHENING

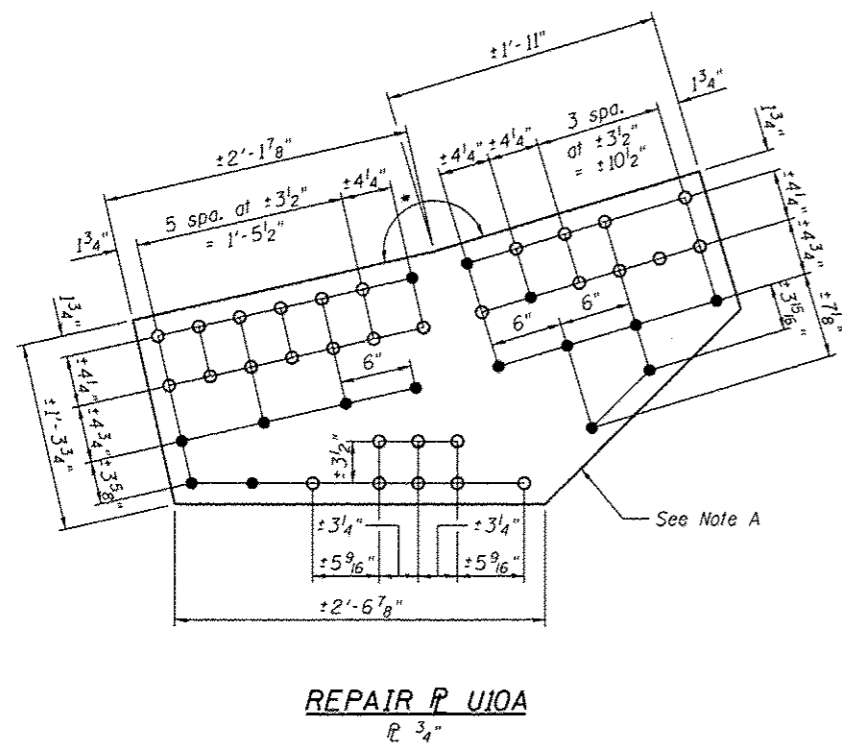

REPAIR P U10A
 P 3/4"

* To be determined in field

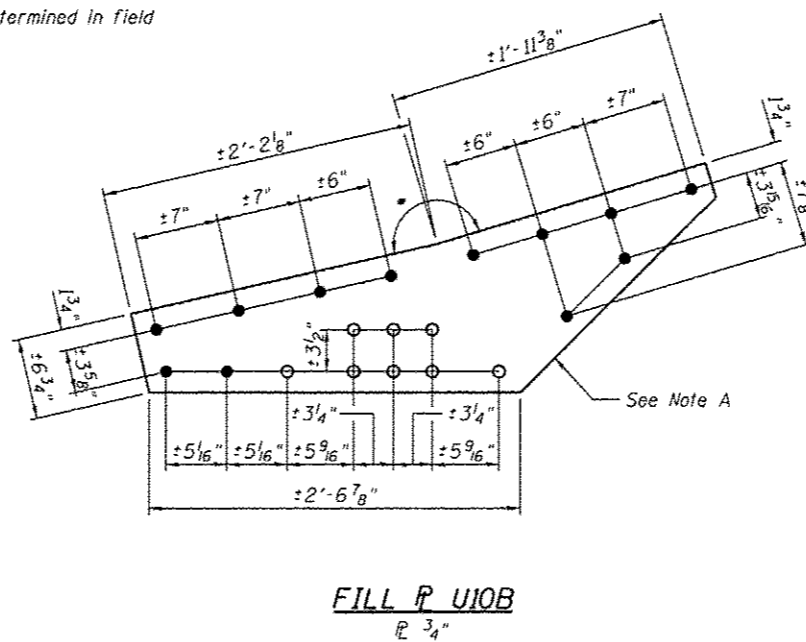

FILL P U10B
 P 3/4"

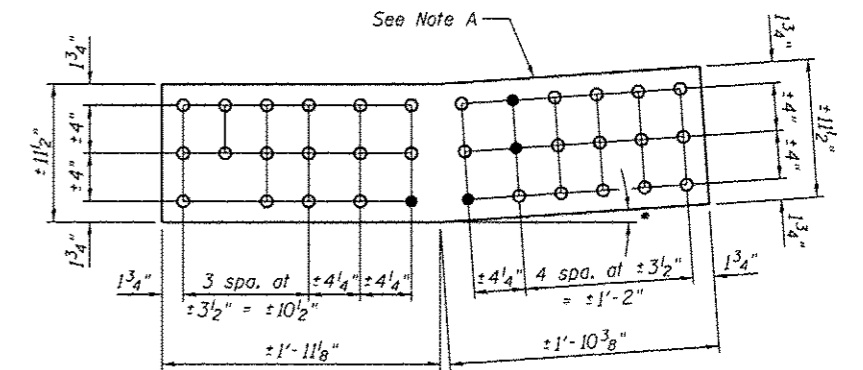

REPAIR P U10C
 P 3/4" x ±11 1/2" x ±3'-9 1/2"

Procedure:
 Install repair plates one at a time.

BILL OF MATERIAL

Item	Unit	Total
Structural Steel Repair	Pound	2,030

Note A:
 Field drill holes (o) using existing holes as template.
 Remainder of holes (•) may be shop or field drilled.

Note:
 All bolted connections shown on this sheet shall be made with 1" dia. H.S. bolts unless otherwise noted.



USER NAME :	DESIGNED - MEL	REVISED
PLOT SCALE :	CHECKED - CDB	REVISED
PLOT DATE :	DRAWN - PRC	REVISED
	CHECKED - MEL	REVISED

STATE OF ILLINOIS
 DEPARTMENT OF TRANSPORTATION

MAIN SPANS GUSSET PLATE STRENGTHENING - 13
 S.N. 082-6001 MLK BRIDGE OVER MISSISSIPPI RIVER

SHEET NO. 558 OF 5138 SHEETS

F.A.P. RTE.	SECTION	COUNTY	TOTAL SHEETS	SHEET NO.
799	IBR, ORS-2	ST. CLAIR	156	76
CONTRACT NO. 76B03			ILLINOIS FED. AID PROJECT	

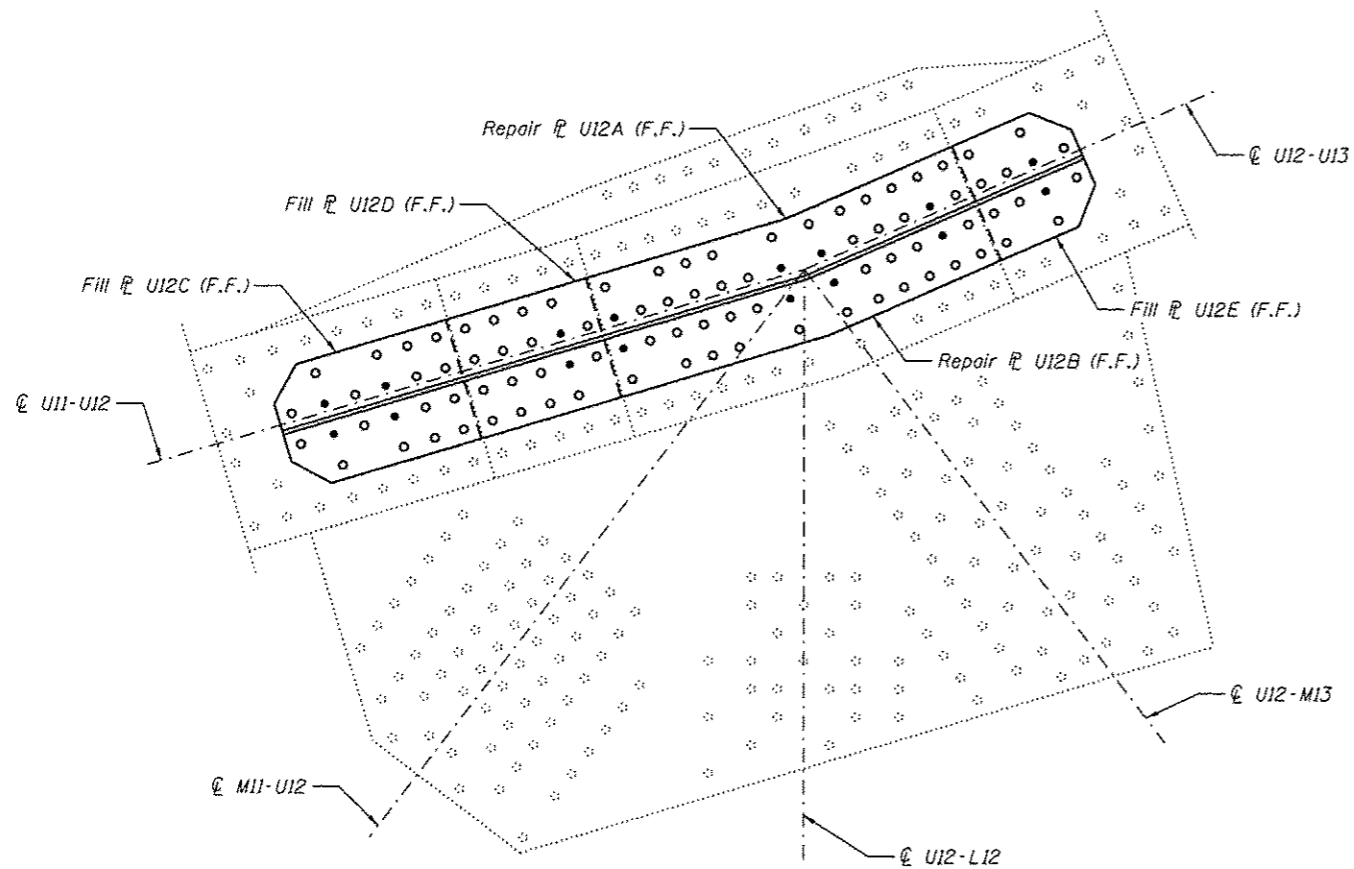

OUTSIDE PLATE AT PANEL POINT U12N AND U12S
 (U12'N AND U12'S SIMILAR)
 (Span 9 and 11)

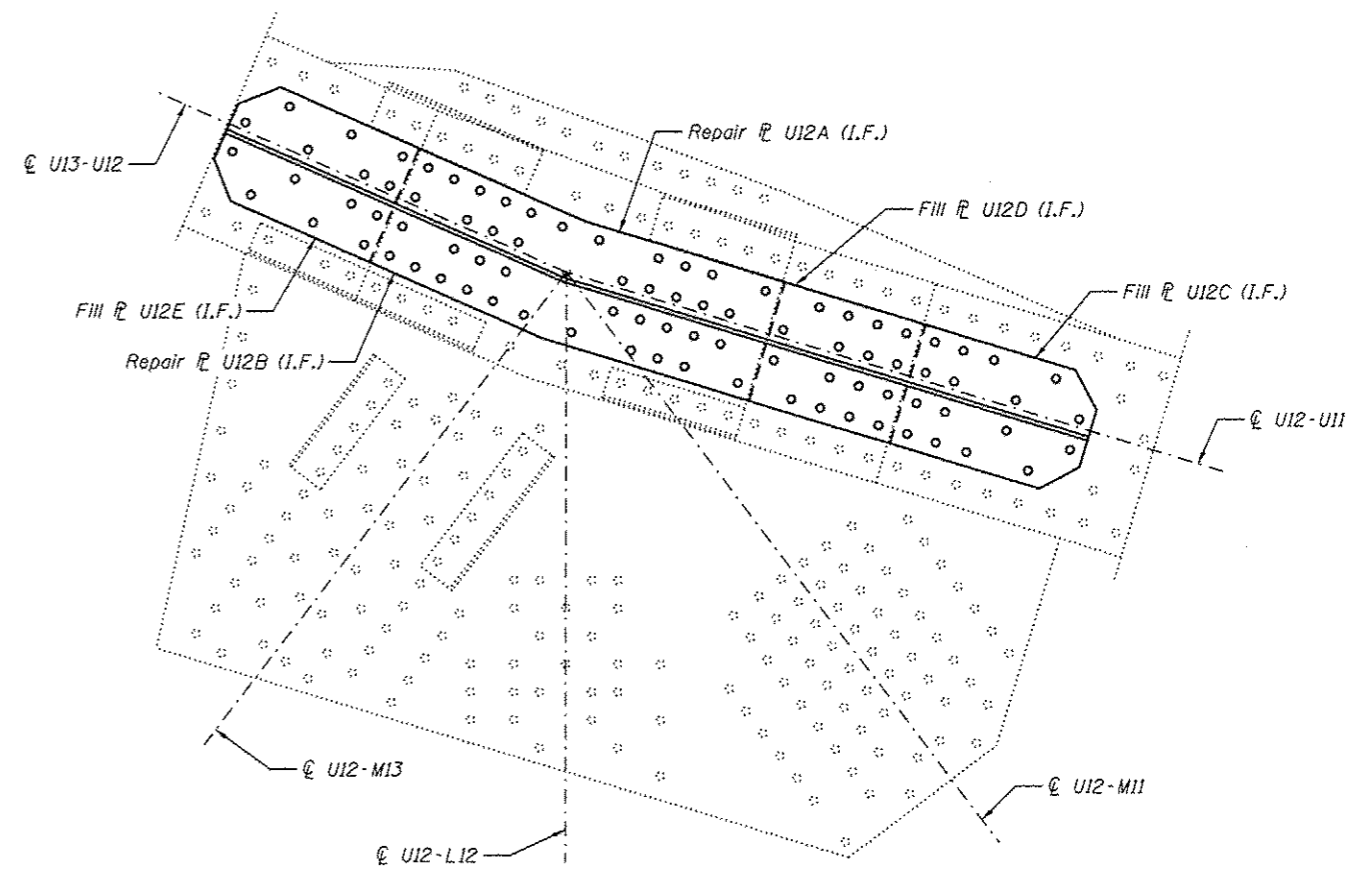

INSIDE PLATE AT PANEL POINT U12N AND U12S
 (U12'N AND U12'S SIMILAR)
 (Span 9 and 11)

GUSSET PLATE STRENGTHENING

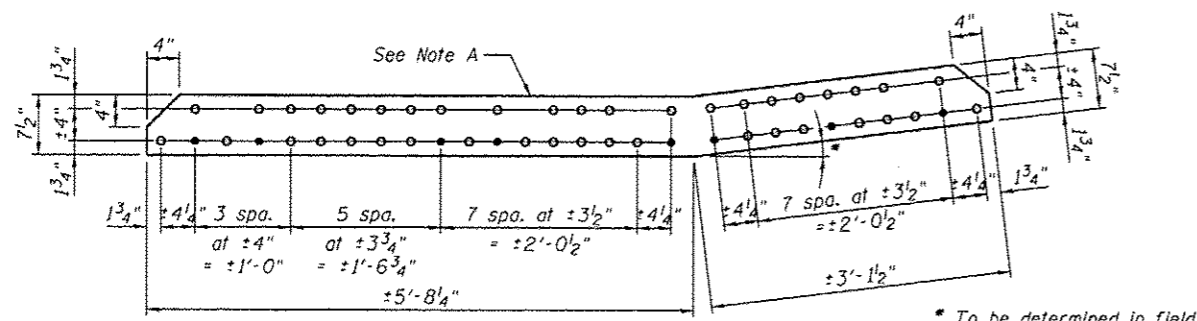

REPAIR P U12A
 P 3/4" x 7/2" x ±8'-9 3/4"

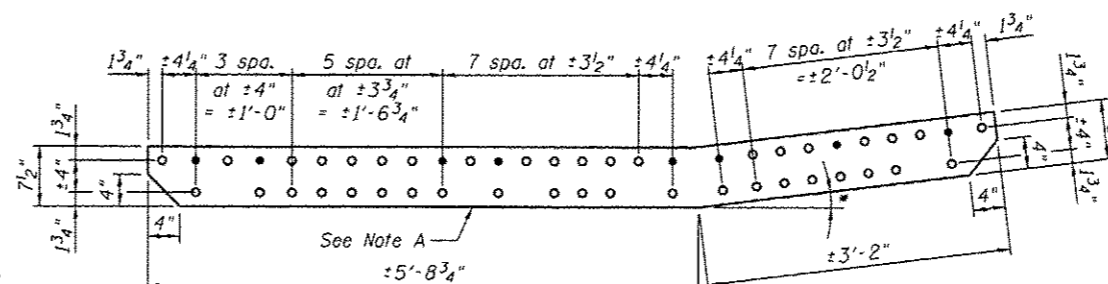

REPAIR P U12B
 P 3/4" x 7/2" x ±8'-10 3/4"

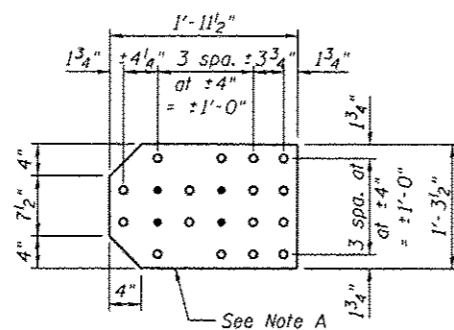

FILL P U12C
 P 1/16" x 15 1/2" x 1'-11 1/2"

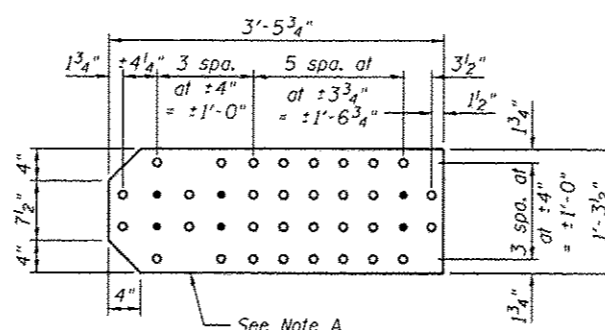

FILL P U12D
 P 3/8" x 15 1/2" x 3'-5 3/4"

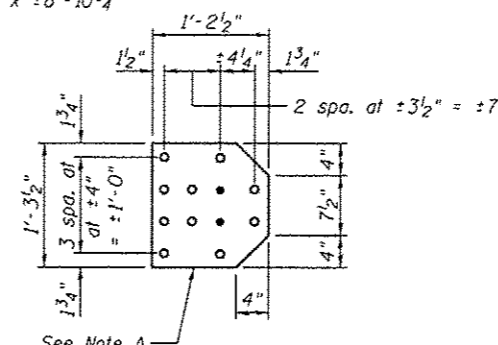

FILL P U12E
 P 3/8" x 14 1/2" x 1'-3 1/2"

Procedure:
 Install repair plates similar to U4N and U4S (U4'N and U4'S).
 See sheet S55.

BILL OF MATERIAL

Item	Unit	Total
Structural Steel Repair	Pound	4,850

Note:
 All bolted connections shown on this sheet shall be made with 1" dia. H.S. bolts unless otherwise noted.
 For front and inside faces of gusset plates, see truss cross section on sheet SB.

Note A:
 Field drill holes (o) using existing holes as template.
 Remainder of holes (•) may be shop or field drilled.



USER NAME =	DESIGNED - MEL	REVISED
PLOT SCALE =	CHECKED - CDB	REVISED
PLOT DATE = 05/02/2014	DRAWN - PRC	REVISED
	CHECKED - MEL	REVISED

STATE OF ILLINOIS
 DEPARTMENT OF TRANSPORTATION

MAIN SPANS GUSSET PLATE STRENGTHENING - 14
 S.N. 082-6001 MLK BRIDGE OVER MISSISSIPPI RIVER

SHEET NO. 559 OF 5138 SHEETS

F.A.P. RTE. 799	SECTION 1BR, DRS-2	COUNTY ST. CLAIR	TOTAL SHEETS 156	SHEET NO. 77
ILLINOIS FED. AID PROJECT			CONTRACT NO. 76B03	

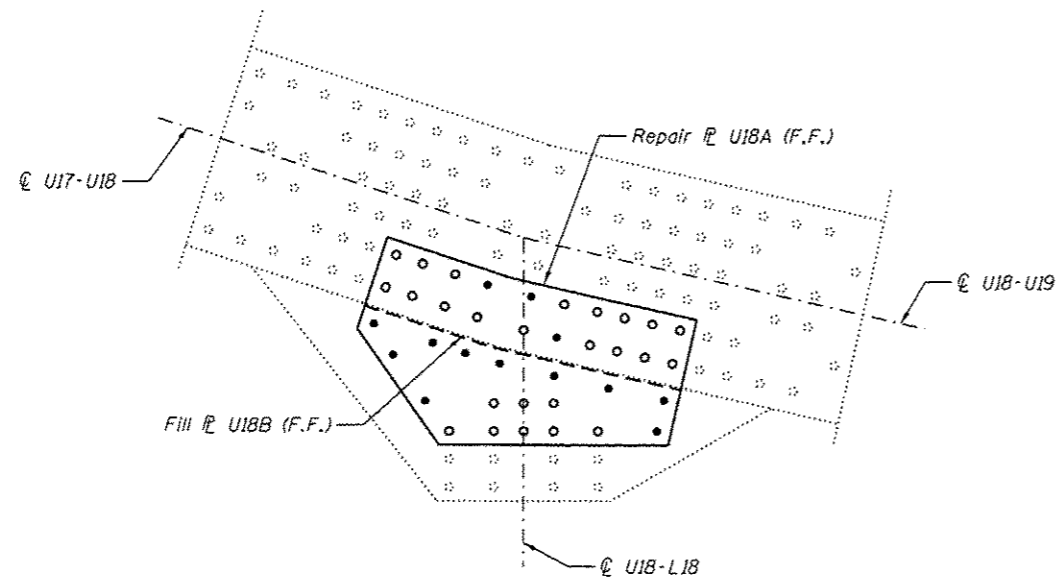

OUTSIDE PLATE AT PANEL POINT U18N AND U18S
 (U18'N AND U18'S SIMILAR)
 (Span 10)

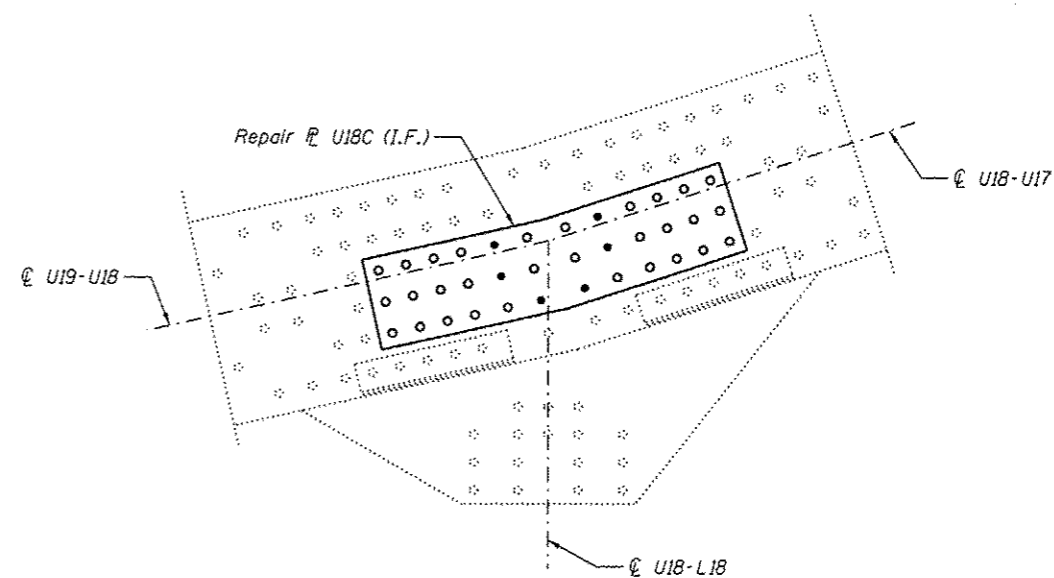

INSIDE PLATE AT PANEL POINT U18N AND U18S
 (U18'N AND U18'S SIMILAR)
 (Span 10)

GUSSET PLATE STRENGTHENING

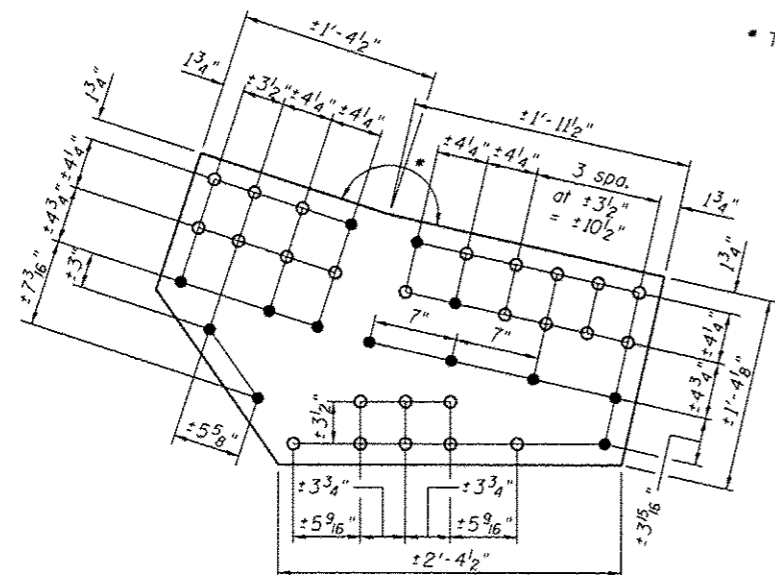

REPAIR P U18A
 P 1"

* To be determined in field

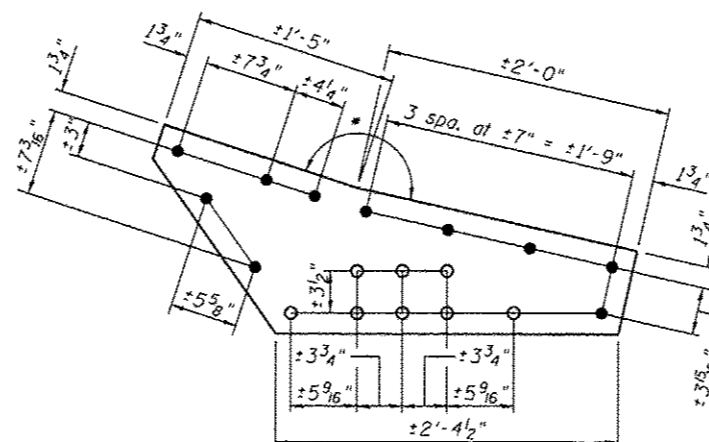

FILL P U18B
 P 3/4"

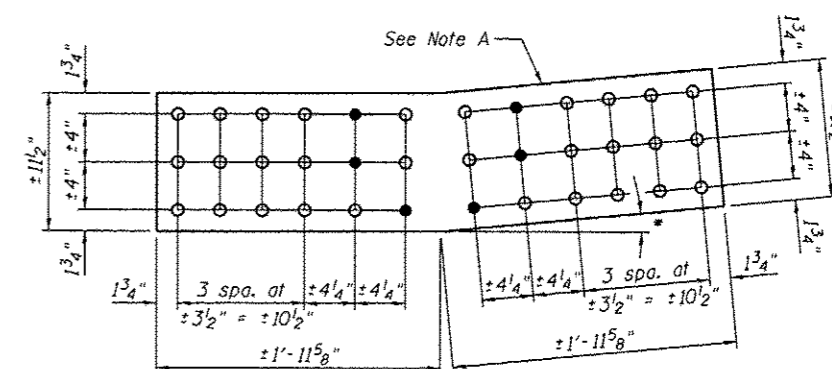

REPAIR P U18C
 P 1" x ±11 1/2" x ±3'-11 1/4"

Procedure:
 Install repair plates one at a time.

BILL OF MATERIAL

Item	Unit	Total
Structural Steel Repair	Pound	2,200

Note A:
 Field drill holes (◦) using existing holes as template.
 Remainder of holes (•) may be shop or field drilled.

Note:
 All bolted connections shown on this sheet shall be made with 1" dia. H.S. bolts unless otherwise noted.
 For front and inside faces of gusset plates, see truss cross section on sheet SB.



USER NAME *	DESIGNED - MEL	REVISED
	CHECKED - CDB	REVISED
PLOT SCALE *	DRAWN - PRC	REVISED
PLOT DATE * 05/02/2014	CHECKED - MEL	REVISED

STATE OF ILLINOIS
DEPARTMENT OF TRANSPORTATION

MAIN SPANS GUSSET PLATE STRENGTHENING - 15
S.N. 082-6001 MLK BRIDGE OVER MISSISSIPPI RIVER

SHEET NO. 560 OF 5138 SHEETS

F.A.P. RTE. 799	SECTION 1BR, DRS-2	COUNTY ST. CLAIR	TOTAL SHEETS 156	SHEET NO. 78
			CONTRACT NO. 76B03	
[ILLINOIS] FED. AID PROJECT				

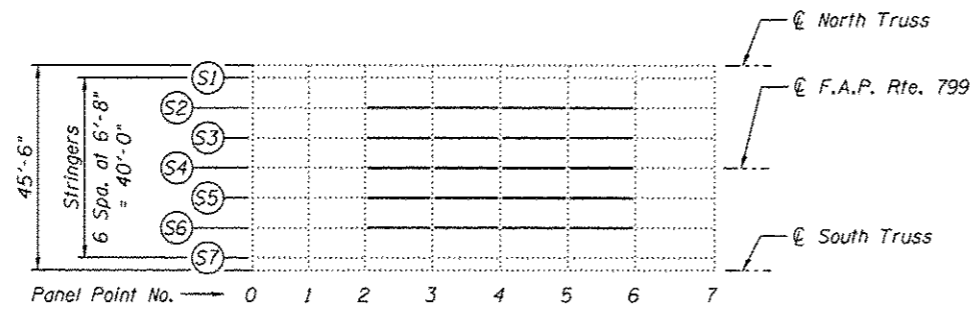

PARTIAL PLAN - SPAN 9

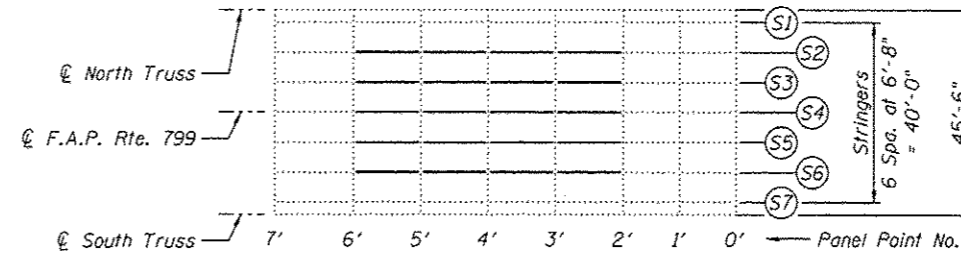

PARTIAL PLAN - SPAN 11

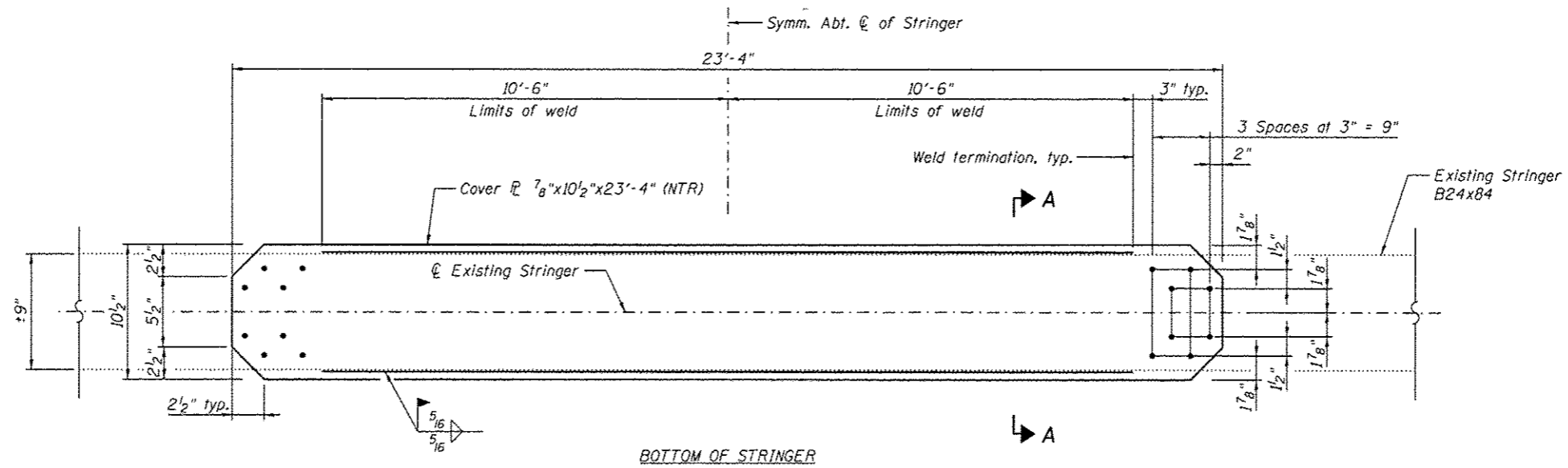

**SPAN 9 AND SPAN 11 STRINGER STRENGTHENING
PANELS PP2-PP6 AND PP2'-PP6'
(40 Locations)**

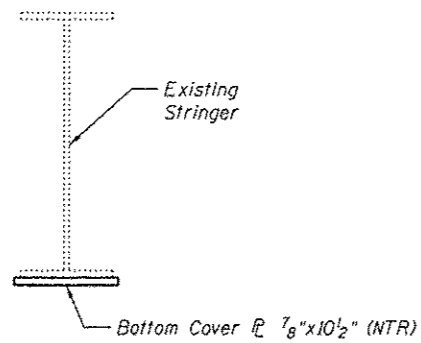

SECTION A-A

BILL OF MATERIAL

Item	Unit	Total
Structural Steel Repair	Pound	30,210

Note:
Load carrying components designed "NTR" shall conform to the Impact Testing Requirement, Zone 2.



USER NAME *	DESIGNED - MEL	REVISED
	CHECKED - COB	REVISED
PLOT SCALE *	DRAWN - AEC	REVISED
PLOT DATE * 05/02/2014	CHECKED - MEL	REVISED

**STATE OF ILLINOIS
DEPARTMENT OF TRANSPORTATION**

**MAIN SPAN STRINGER STRENGTHENING PP2-PP6 AND PP2'-PP6'
S.N. 082-6001 MLK BRIDGE OVER MISSISSIPPI RIVER**

SHEET NO. S61 OF S13B SHEETS

F.A.P. RTE.	SECTION	COUNTY	TOTAL SHEETS	SHEET NO.
799	1BR. DRS-2	ST. CLAIR	156	79
				CONTRACT NO. 76B03
ILLINOIS FED. AID PROJECT				

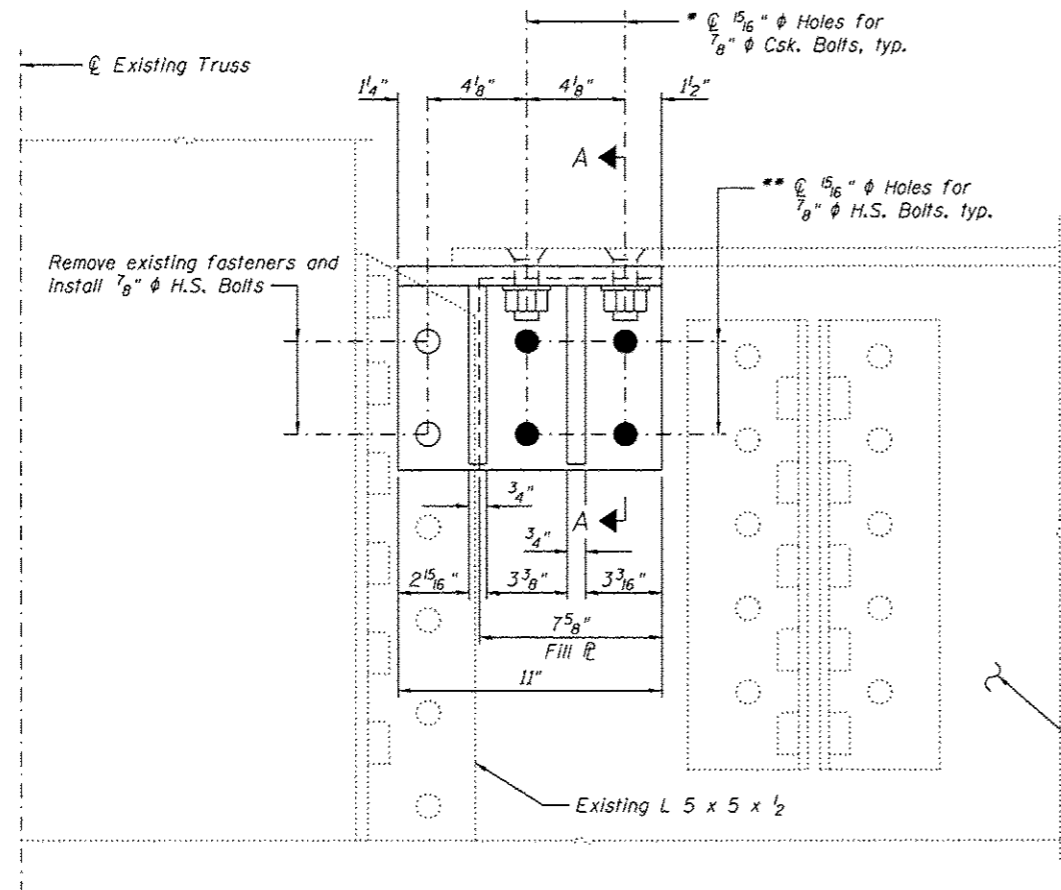

ELEVATION VIEW - END OF FLOORBEAM
(Required each end of floorbeam)

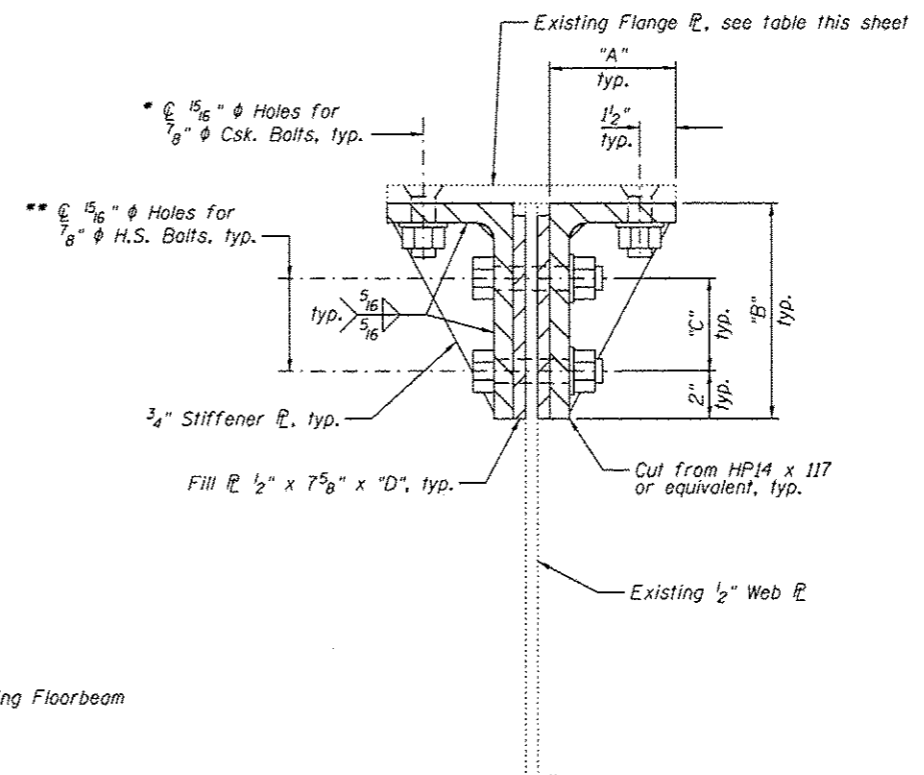

SECTION A-A

- * Drill countersunk holes in floorbeam flange
- ** Drill holes in floorbeam web, where applicable

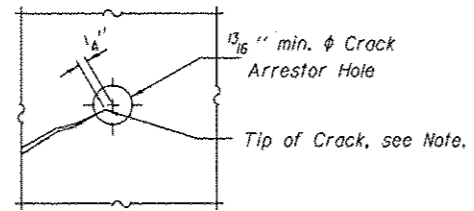

CRACK ARRESTOR HOLE DETAIL

Note: Locate crack tip using liquid dye penetrant or magnetic particle testing. Drill 1 3/16 inch min. diameter Crack Arrestor hole at the crack tip. After crack arrestor hole has been drilled, dye penetrant or magnetic particle testing shall be used to verify that the drilled hole has captured the crack tip. Cost shall be included with Structural Steel Repair.

FLOORBEAM RETROFIT - GRID DECK

LOCATION	DIMENSION				EXISTING TOP FLG.
	"A"	"B"	"C"	"D"	
FB17 & FB17'	7 1/4"	8 1/4"	3 7/8"	7 3/4"	16" x 1 1/2"
FB20, FB22, FB25, FB20', FB22' & FB25'	7 1/4"	8 3/4"	3 7/8"	8 1/4"	16" x 1"

Notes:
Install floorbeam retrofit during grid deck replacement to facilitate access to the floorbeam flange.
All webs shall be checked for cracks and arrestor holes drilled before plates added.
Countersunk fasteners shall be galvanized ASTM A449.

BILL OF MATERIAL

Item	Unit	Total
Structural Steel Repair	Pound	4180



USER NAME *	DESIGNED - PRC	REVISED
	CHECKED - CDB	REVISED
PLOT SCALE *	DRAWN - PRC	REVISED
PLOT DATE * 05/02/2014	CHECKED - CDB	REVISED

STATE OF ILLINOIS
DEPARTMENT OF TRANSPORTATION

MAIN SPANS FLOORBEAM RETROFIT DETAILS - 1
S.N. 082-6001 MLK BRIDGE OVER MISSISSIPPI RIVER

SHEET NO. 562 OF 5138 SHEETS

F.A.P. RTE.	SECTION	COUNTY	TOTAL SHEETS	SHEET NO.
799	1BR, ORS-2	ST. CLAIR	156	80
CONTRACT NO. 76B03			ILLINOIS FED. AID PROJECT	

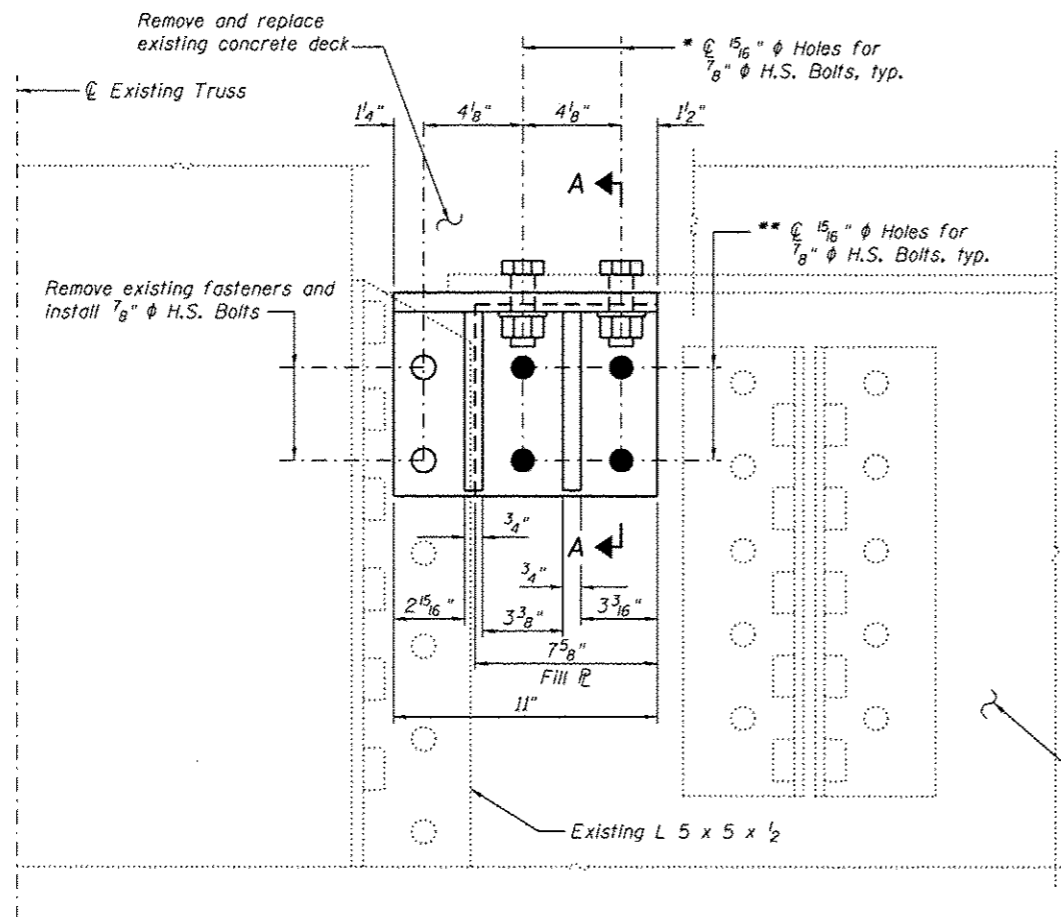

ELEVATION VIEW - END OF FLOORBEAM
(Required each end of floorbeam)

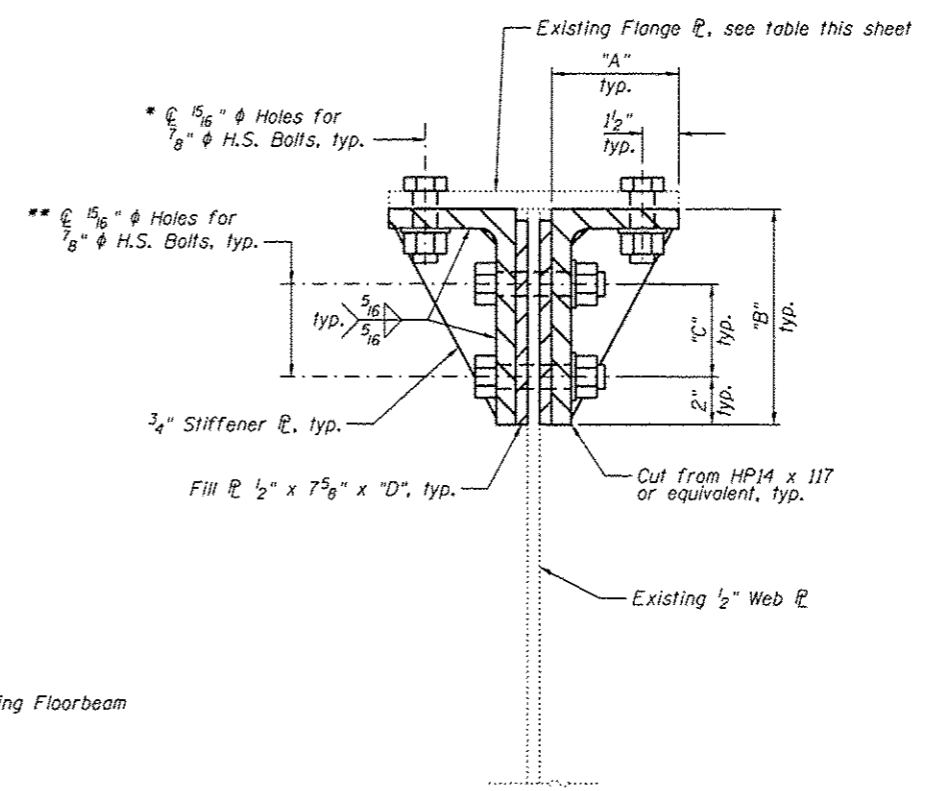

- * Drill holes in floorbeam flange
- ** Drill holes in floorbeam web, where applicable

SECTION A-A

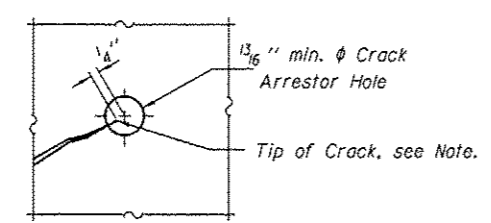

CRACK ARRESTOR HOLE DETAIL

Note: Locate crack tip using liquid dye penetrant or magnetic particle testing. Drill 13/16" min. Holes for 7/8" H.S. Bolts, typ. After crack arrestor hole has been drilled, dye penetrant or magnetic particle testing shall be used to verify that the drilled hole has captured the crack tip. Cost shall be included with Structural Steel Repair.

FLOORBEAM RETROFIT - CONCRETE DECK

LOCATION	DIMENSION				EXISTING TOP FLG.
	"A"	"B"	"C"	"D"	
FB14 & FB14'	5 1/4"	9"	3 7/8"	8 1/2"	12" x 3/4"
FBB'	7 1/4"	8"	3 3/4"	7 1/2"	16" x 1 1/2"

Notes:
All webs shall be checked for cracks and arrestor holes drilled before plates added.
For concrete deck removal details, see sheets S28 and S29.

BILL OF MATERIAL

Item	Unit	Total
Structural Steel Repair	Pound	1540



USER NAME *	DESIGNED - PRC	REVISED
	CHECKED - CDB	REVISED
PLOT SCALE *	DRAWN - PRC	REVISED
PLOT DATE * 05/02/2014	CHECKED - CDB	REVISED

STATE OF ILLINOIS
DEPARTMENT OF TRANSPORTATION

MAIN SPANS FLOORBEAM RETROFIT DETAILS - 2
S.N. 082-6001 MLK BRIDGE OVER MISSISSIPPI RIVER

SHEET NO. 563 OF 5138 SHEETS

F.A.P. RTE. 799	SECTION IBR, DRS-2	COUNTY ST. CLAIR	TOTAL SHEETS 156	SHEET NO. 81
				CONTRACT NO. 76B03
ILLINOIS FED. AID PROJECT				

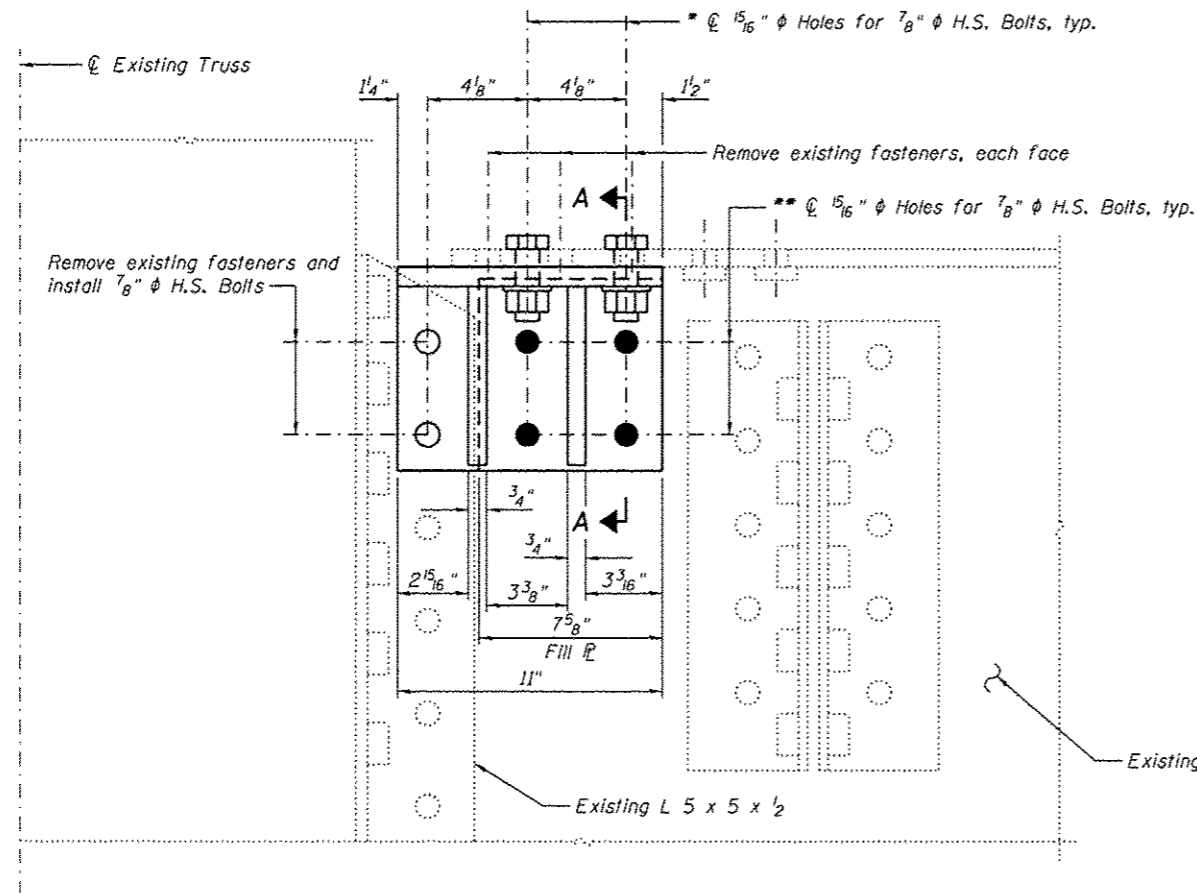

ELEVATION VIEW - END OF FLOORBEAM FBO'
(Required each end of floorbeam)

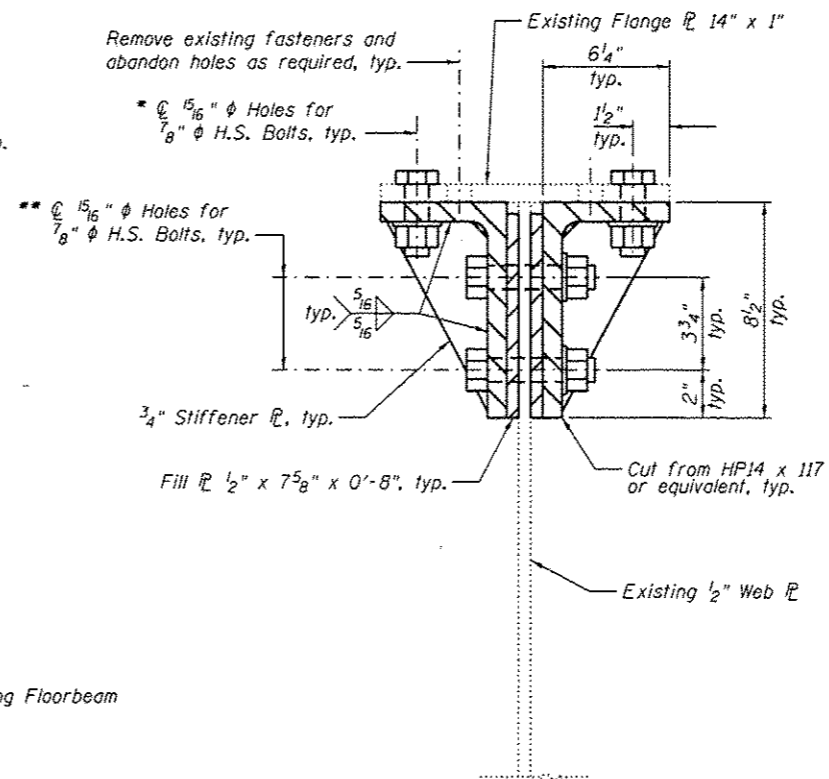

SECTION A-A

- * Drill holes in floorbeam flange
- ** Drill holes in floorbeam web, where applicable

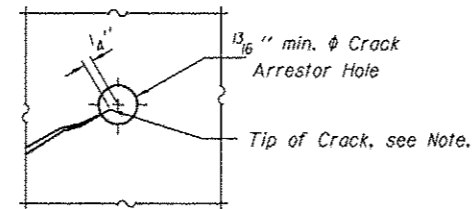

CRACK ARRESTOR HOLE DETAIL

Note: Locate crack tip using liquid dye penetrant or magnetic particle testing. Drill 13/16 inch min. diameter Crack Arrestor hole at the crack tip. After crack arrestor hole has been drilled, dye penetrant or magnetic particle testing shall be used to verify that the drilled hole has captured the crack tip. Cost shall be included with Structural Steel Repair.

Notes:
The web shall be checked for cracks and arrestor holes drilled before plates added.
For finger plate expansion joint removal and resetting, see sheet S101.
Fill abandoned holes with tight fitting steel plug coated with epoxy and grind smooth.

BILL OF MATERIAL

Item	Unit	Total
Structural Steel Repair	Pound	520



USER NAME :	DESIGNED - PRC	REVISED
	CHECKED - CDB	REVISED
PLOT SCALE :	DRAWN - PRC	REVISED
PLOT DATE : 05/02/2014	CHECKED - CDB	REVISED

STATE OF ILLINOIS
DEPARTMENT OF TRANSPORTATION

MAIN SPANS FLOORBEAM RETROFIT DETAILS - 3
S.N. 082-6001 MLK BRIDGE OVER MISSISSIPPI RIVER

F.A.P. RTE.	SECTION	COUNTY	TOTAL SHEETS	SHEET NO.
799	IBR, DRS-2	ST. CLAIR	156	82
			CONTRACT NO. 76B03	
			ILLINOIS FED. AID PROJECT	

SHEET NO. S64 OF S138 SHEETS

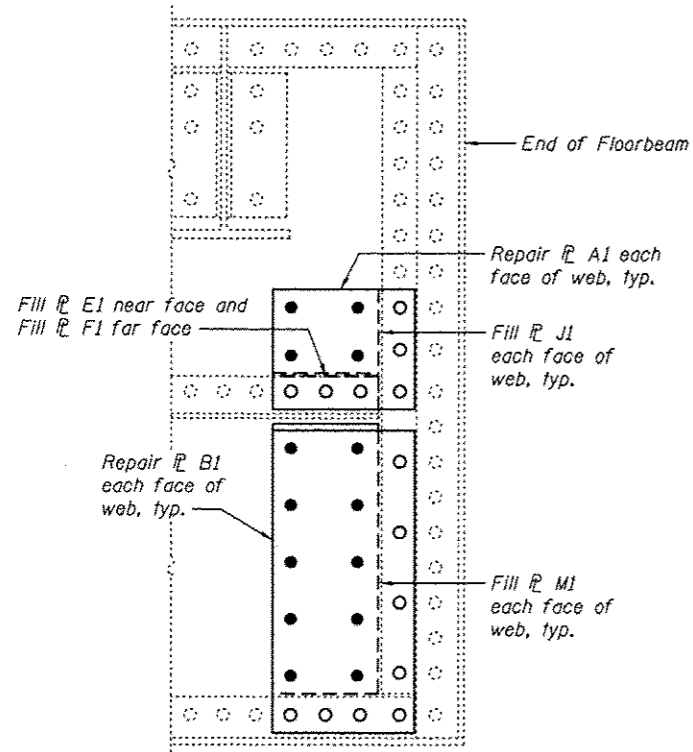

SOUTH END AT PANEL POINT L1
West face shown
Span 9

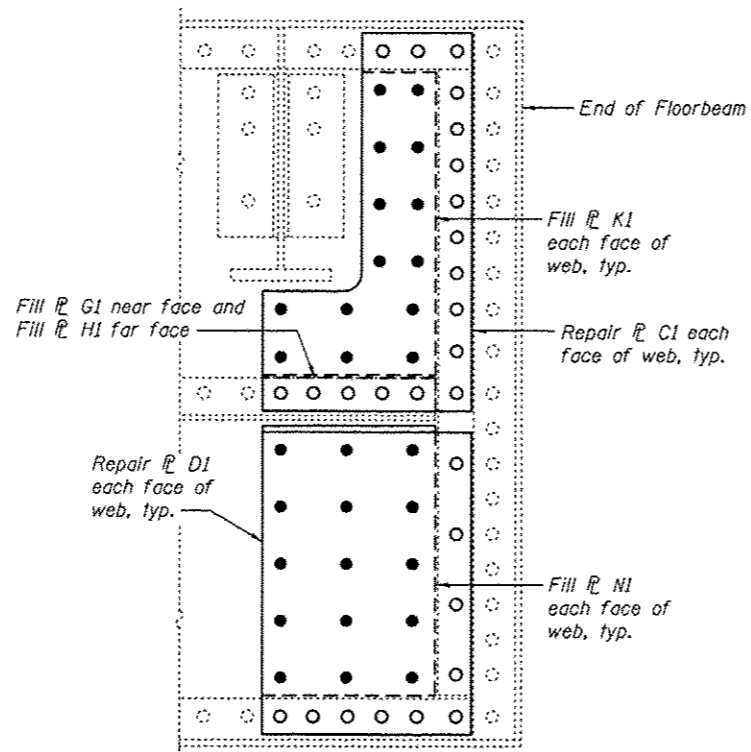

SOUTH END AT PANEL POINT L3
West face shown
Span 9

FLOORBEAM WEB REPAIRS

Note A:
Field drill holes using existing holes as template.
Remainder of holes may be shop or field drilled.

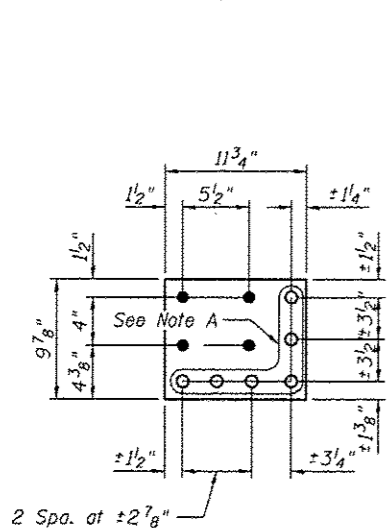

REPAIR P A1
P 3/8" x 9 7/8" x 0'-11 3/4"

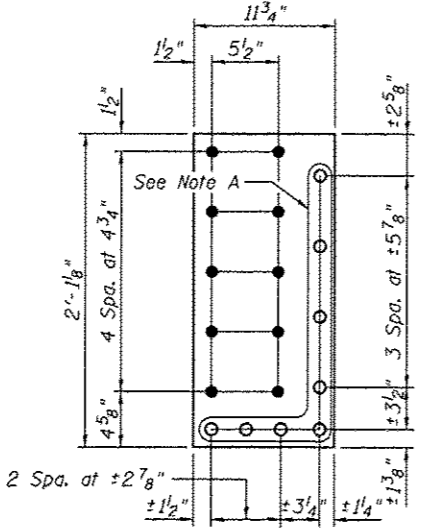

REPAIR P B1
P 3/8" x 11 3/4" x 2'-1 1/8"

* Grind smooth to an ANSI 250 finish

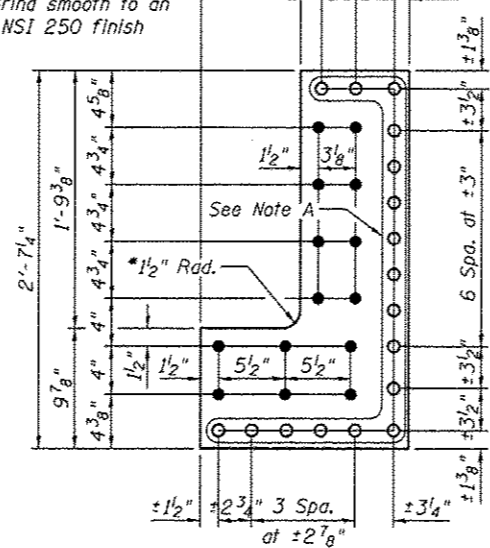

REPAIR P C1
P 3/8" x 17 3/8" x 2'-7 1/4"

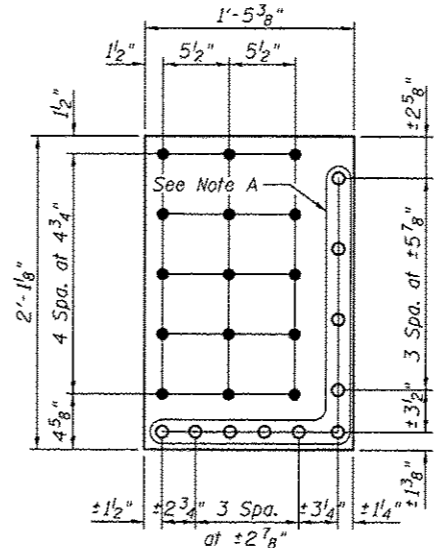

REPAIR P D1
P 3/8" x 17 3/8" x 2'-1 1/8"

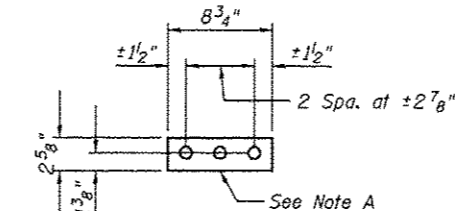

FILL P E1
P 3/16" x 2 5/8" x 0'-8 3/4"

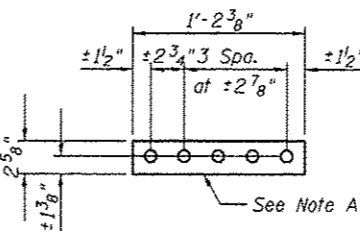

FILL P G1
P 3/16" x 2 5/8" x 1'-2 3/8"

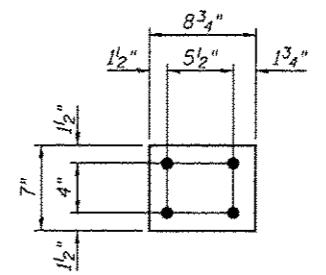

FILL P J1
P 9/16" x 7" x 0'-8 3/4"

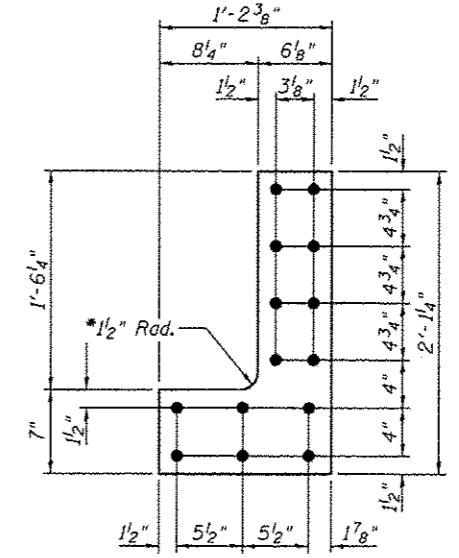

FILL P K1
P 9/16" x 14 3/8" x 2'-1 1/4"

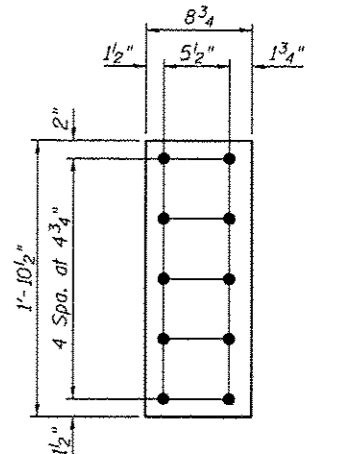

FILL P M1
P 9/16" x 8 3/4" x 1'-10 1/2"

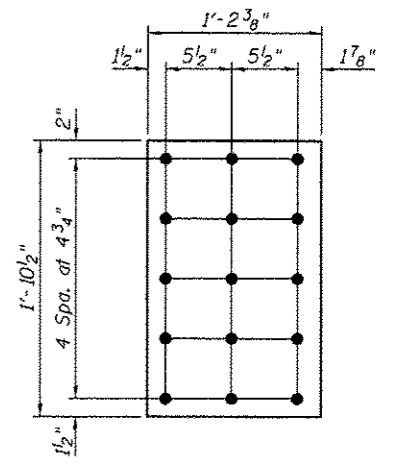

FILL P N1
P 9/16" x 14 3/8" x 1'-10 1/2"

BILL OF MATERIAL

Item	Unit	Total
Structural Steel Repair	Pound	600



USER NAME :	DESIGNED - PRC	REVISED
PLOT SCALE :	CHECKED - COB	REVISED
PLOT DATE :	DRAWN - PRC	REVISED
	CHECKED - COB	REVISED

STATE OF ILLINOIS
DEPARTMENT OF TRANSPORTATION

MAIN SPANS FLOORBEAM WEB REPAIRS - 1
S.N. 082-6001 MLK BRIDGE OVER MISSISSIPPI RIVER

SHEET NO. S65 OF S138 SHEETS

F.A.P. RTE.	SECTION	COUNTY	TOTAL SHEETS	SHEET NO.
799	1BR, DRS-2	ST. CLAIR	156	83
			CONTRACT NO. 76803	
ILLINOIS FED. AID PROJECT				

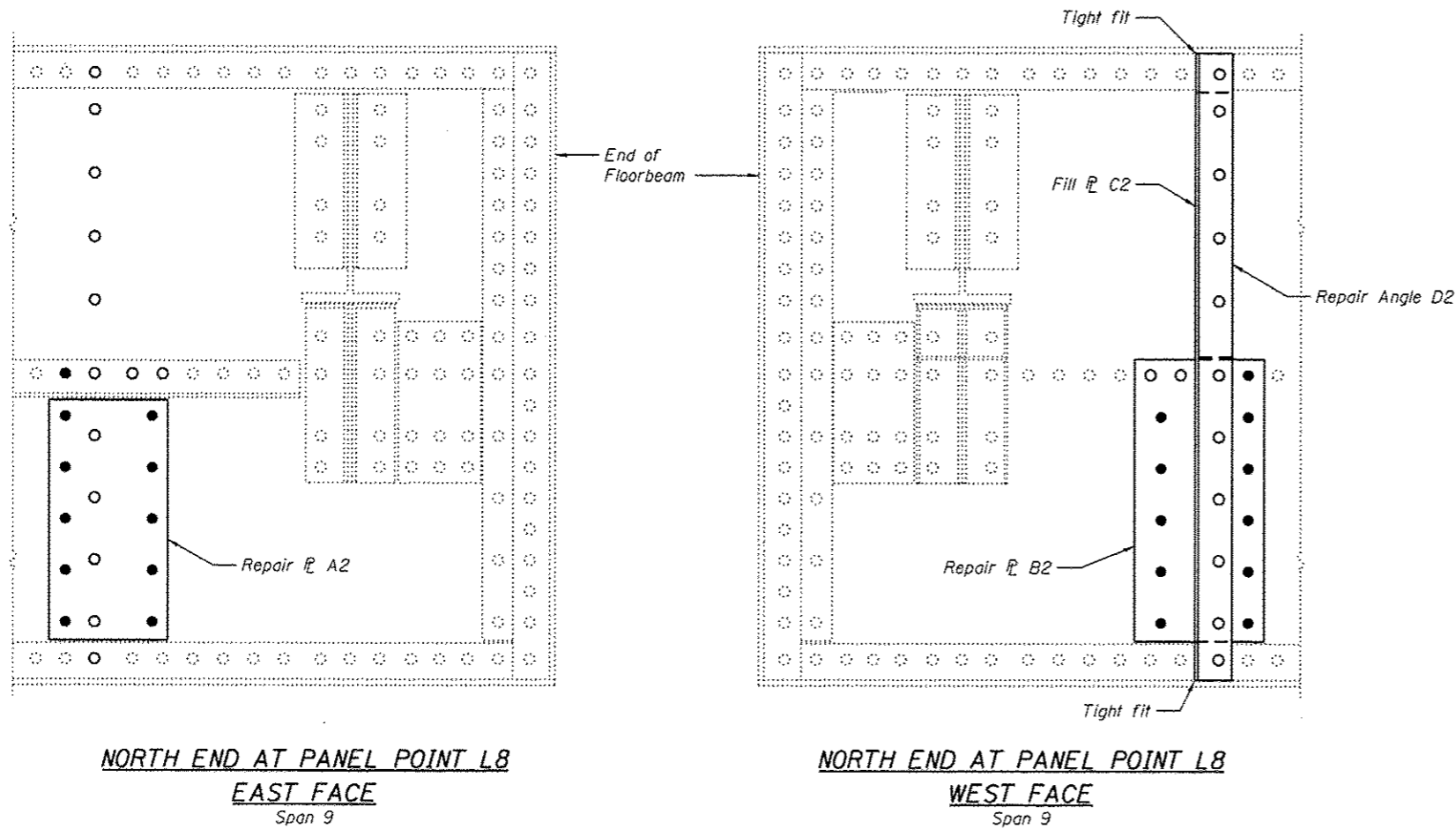

NORTH END AT PANEL POINT L8
EAST FACE
Span 9

NORTH END AT PANEL POINT L8
WEST FACE
Span 9

FLOORBEAM WEB REPAIRS

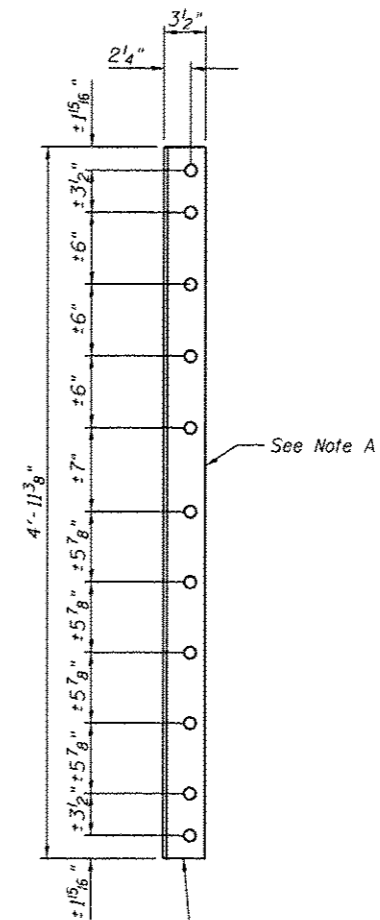

REPAIR ANGLE D2
L5x3 1/2 x 5/16 x 4'-11 3/8"

Note A:
Field drill holes using existing holes as template.
Remainder of holes may be shop or field drilled.

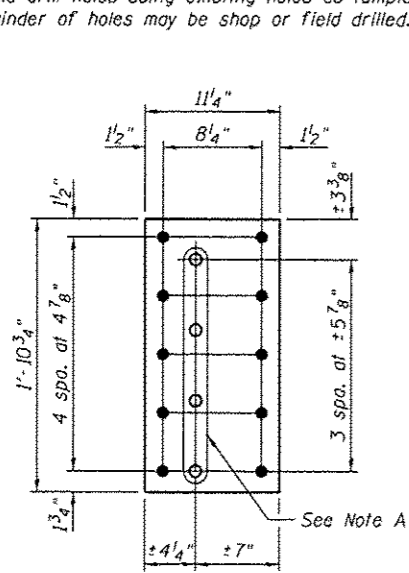

REPAIR P A2
P 3/8" x 11 1/4" x 1'-10 3/4"

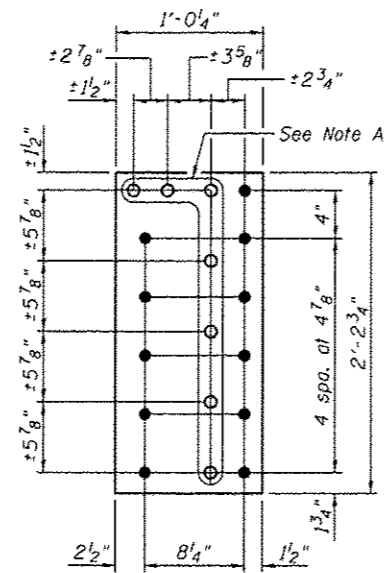

REPAIR P B2
P 9/16" x 12 1/4" x 2'-2 3/4"

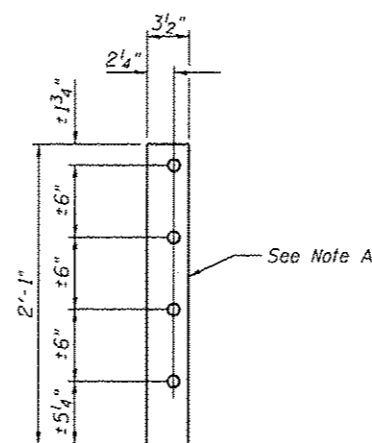

FILL P C2
P 9/16" x 3 1/2" x 2'-1"

BILL OF MATERIAL

Item	Unit	Total
Structural Steel Repair	Pound	160



USER NAME =	DESIGNED - PRC	REVISED
	CHECKED - CDB	REVISED
PLOT SCALE =	DRAWN - PRC	REVISED
PLOT DATE = 05/02/2014	CHECKED - CDB	REVISED

STATE OF ILLINOIS
DEPARTMENT OF TRANSPORTATION

MAIN SPANS FLOORBEAM WEB REPAIRS - 2
S.N. 082-6001 MLK BRIDGE OVER MISSISSIPPI RIVER

F.A.P. RTE. 799	SECTION 1BR, DRS-2	COUNTY ST. CLAIR	TOTAL SHEETS 156	SHEET NO. 84
CONTRACT NO. 76B03			ILLINOIS FED. AID PROJECT	

SHEET NO. 566 OF 5138 SHEETS

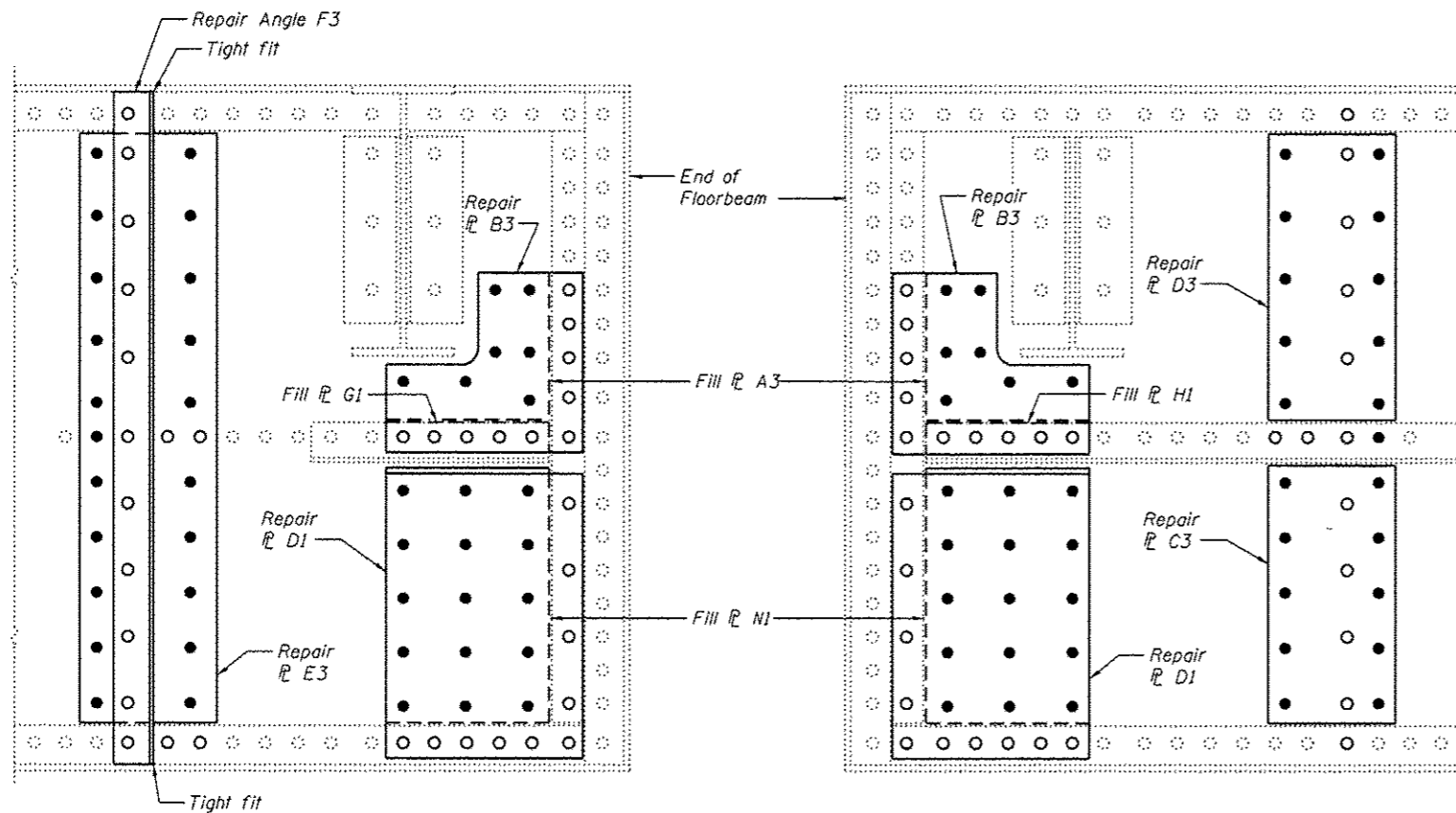

**SOUTH END AT PANEL POINT L9
WEST FACE**
Span 9

**SOUTH END AT PANEL POINT L9
EAST FACE**
Span 9

FLOORBEAM WEB REPAIRS

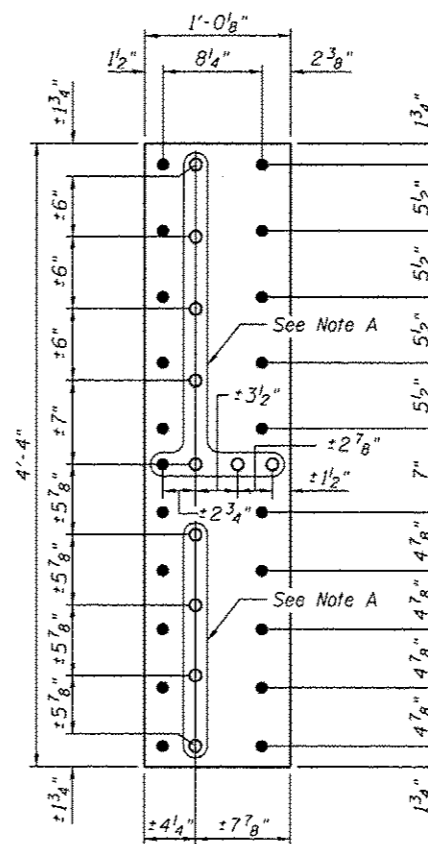

REPAIR R E3
R 3/8" x 12 7/8" x 4'-4"

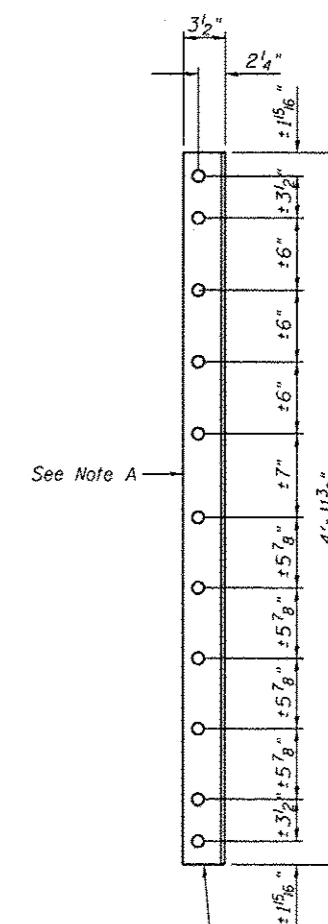

REPAIR ANGLE F3
L5x3 1/2 x 5 1/16 x 4'-11 3/8"

Grind edge of angle leg (short side) to fit existing fillet, top and bottom

Note A:
Field drill holes using existing holes as template. Remainder of holes may be shop or field drilled.

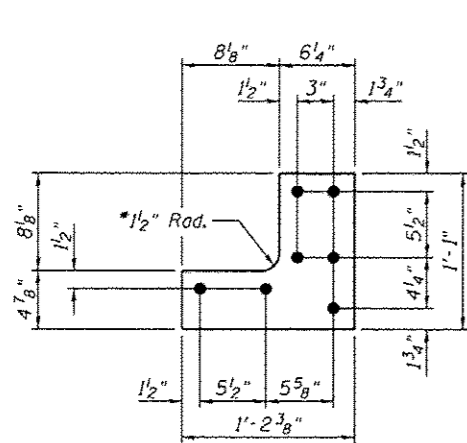

FILL R A3
R 3/16" x 13" x 1'-2 3/8"

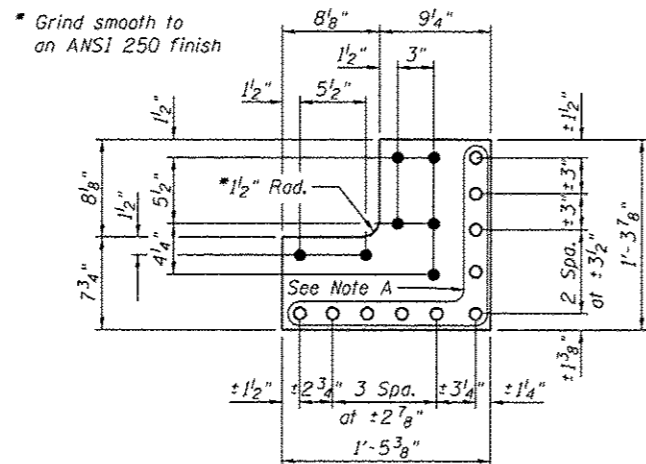

REPAIR R B3
R 3/8" x 15 7/8" x 1'-5 3/8"

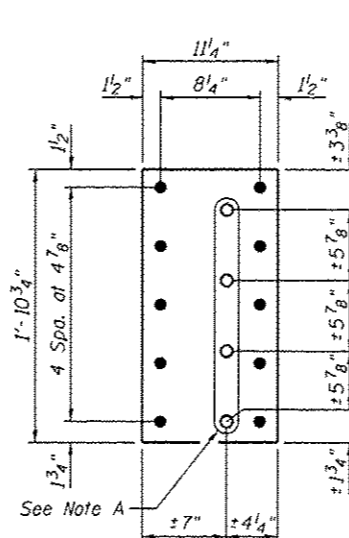

REPAIR R C3
R 3/8" x 11 1/4" x 1'-10 3/4"

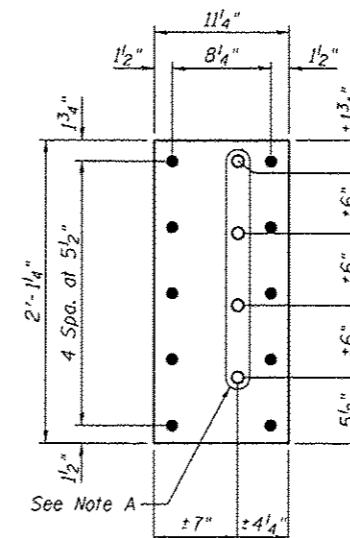

REPAIR R D3
R 3/8" x 11 1/4" x 2'-1 1/4"

Note:
See sheet S65 for additional repair and fill plate details.

BILL OF MATERIAL

Item	Unit	Total
Structural Steel Repair	Pound	560



USER NAME	DESIGNED - PRC	REVISED
PLOT SCALE	CHECKED - CDB	REVISED
PLOT DATE - 05/02/2014	DRAWN - PRC	REVISED
	CHECKED - CDB	REVISED

**STATE OF ILLINOIS
DEPARTMENT OF TRANSPORTATION**

**MAIN SPANS FLOORBEAM WEB REPAIRS - 3
S.N. 082-6001 MLK BRIDGE OVER MISSISSIPPI RIVER**

SHEET NO. S67 OF S138 SHEETS

F.A.P. RTE. 799	SECTION IBR, ORS-2	COUNTY ST. CLAIR	TOTAL SHEETS 156	SHEET NO. 85
			CONTRACT NO. 76B03	
ILLINOIS FED. AID PROJECT				

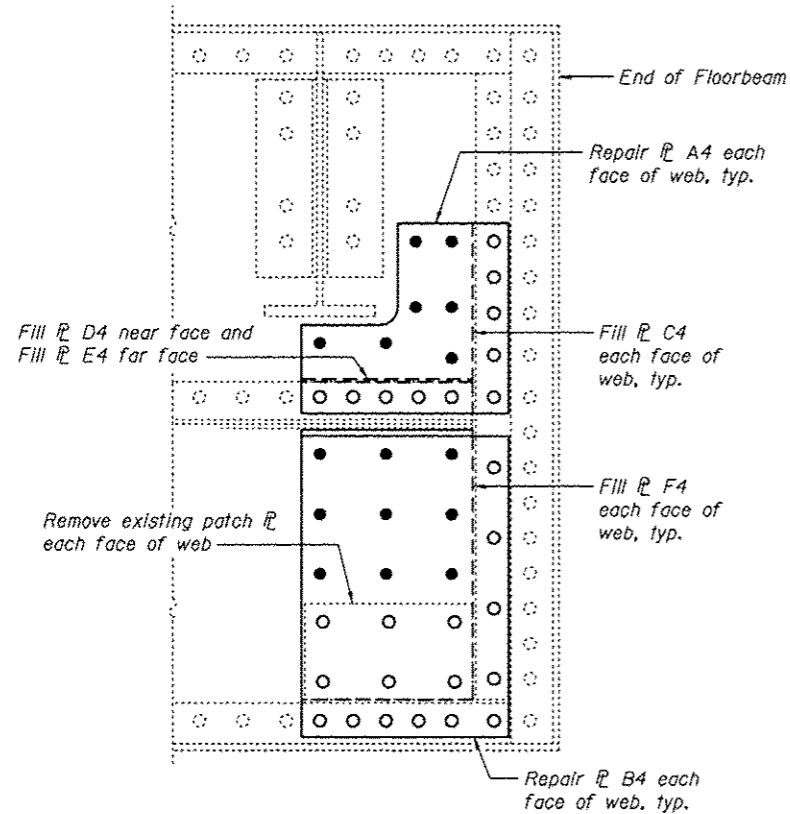

SOUTH END AT PANEL POINT L10

West face shown
Span 9

FLOORBEAM WEB REPAIRS

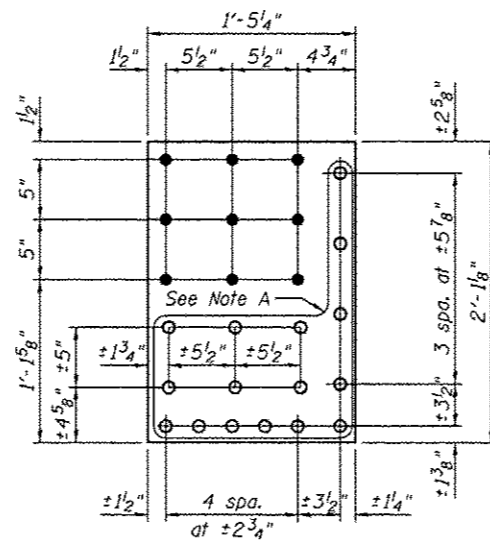

REPAIR R B4

R 3/8" x 17 1/4" x 2'-1 1/8"

* Grind smooth to an ANSI 250 finish

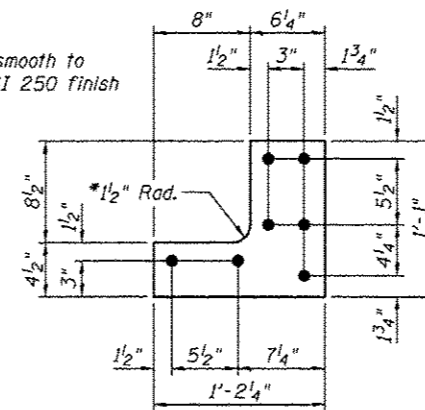

FILL F C4

F 9/16" x 13" x 1'-2 1/4"

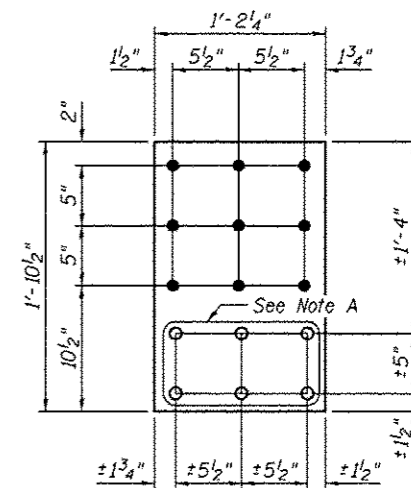

FILL F F4

F 9/16" x 14 1/4" x 1'-10 1/2"

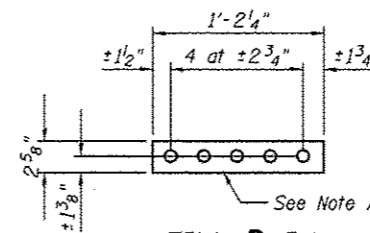

FILL F D4

F 3/16" x 2 5/8" x 1'-2 1/4"

FILL F E4

F 1/4" x 2 5/8" x 1'-2 1/4"

Note A:
Field drill holes using existing holes as template.
Remainder of holes may be shop or field drilled.

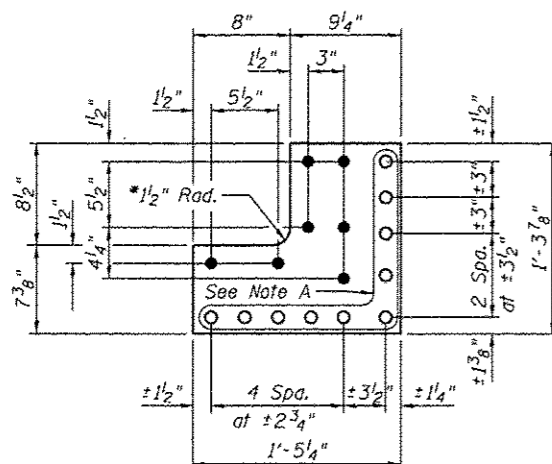

REPAIR R A4

R 3/8" x 15 7/8" x 1'-5 1/4"

BILL OF MATERIAL

Item	Unit	Total
Structural Steel Repair	Pound	320



USER NAME =
DESIGNED - PRC
CHECKED - CDB
PLOT SCALE =
DRAWN - PRC
PLOT DATE = 03/20/2014
CHECKED - CDB
REVISED

DESIGNED - PRC
CHECKED - CDB
DRAWN - PRC
CHECKED - CDB
REVISED

STATE OF ILLINOIS
DEPARTMENT OF TRANSPORTATION

MAIN SPANS FLOORBEAM WEB REPAIRS - 4
S.N. 082-6001 MLK BRIDGE OVER MISSISSIPPI RIVER

SHEET NO. 568 OF 5138 SHEETS

F.A.P. RTE.	SECTION	COUNTY	TOTAL SHEETS	SHEET NO.
799	IBR, DRS-2	ST. CLAIR	156	86

CONTRACT NO. 76B03
ILLINOIS FED. AID PROJECT

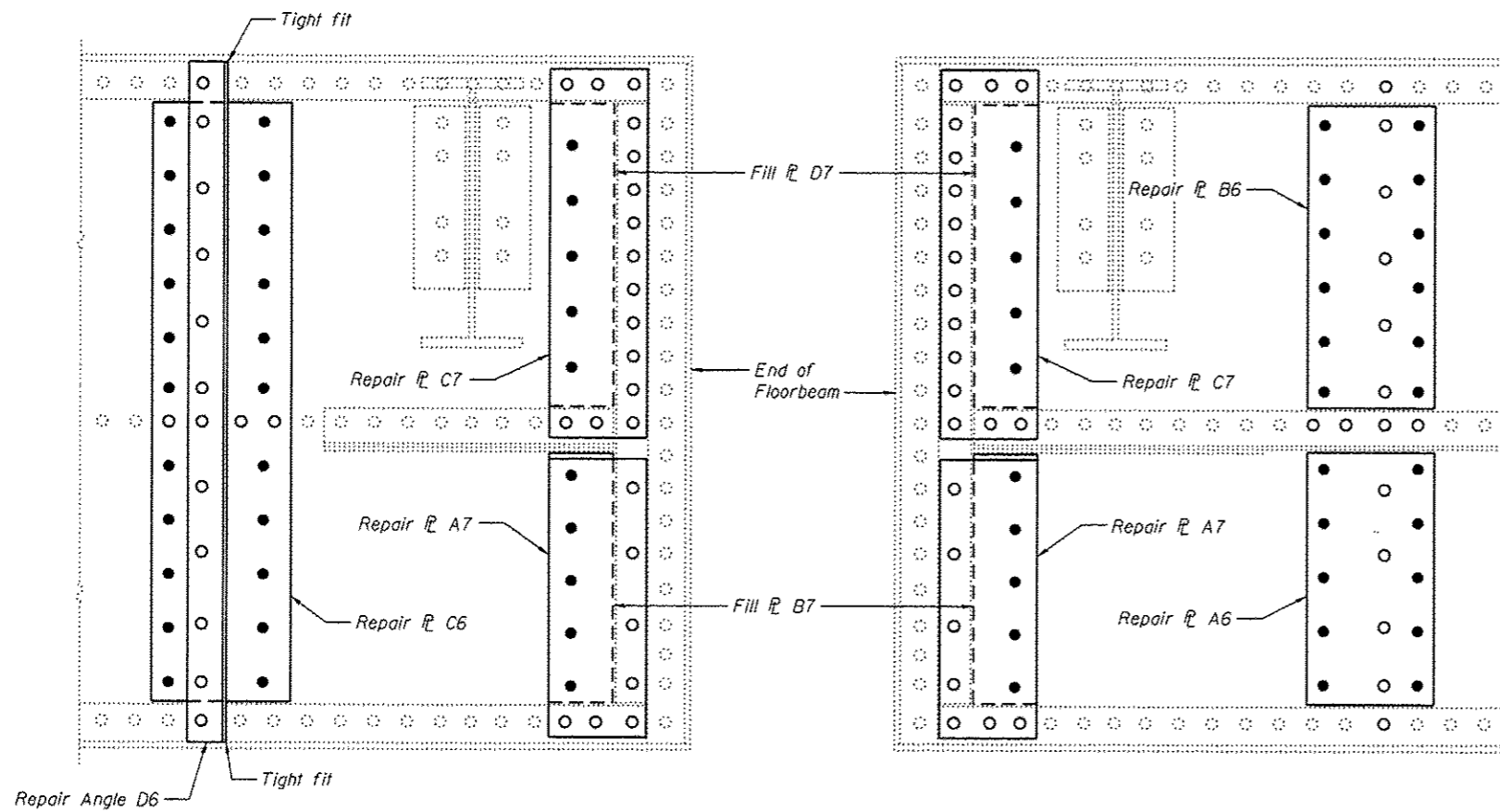

SOUTH END AT PANEL POINT L16
WEST FACE
Span 10

SOUTH END AT PANEL POINT L16
EAST FACE
Span 10

FLOORBEAM WEB REPAIRS

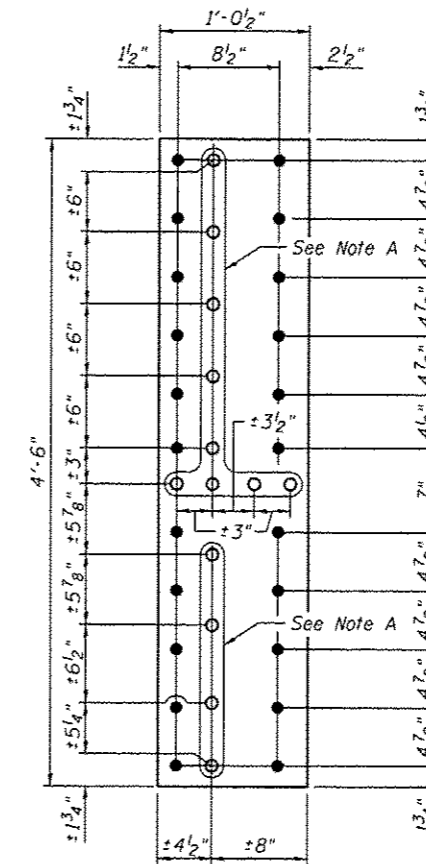

REPAIR R C6
R 3/16" x 12 1/2" x 4'-6"

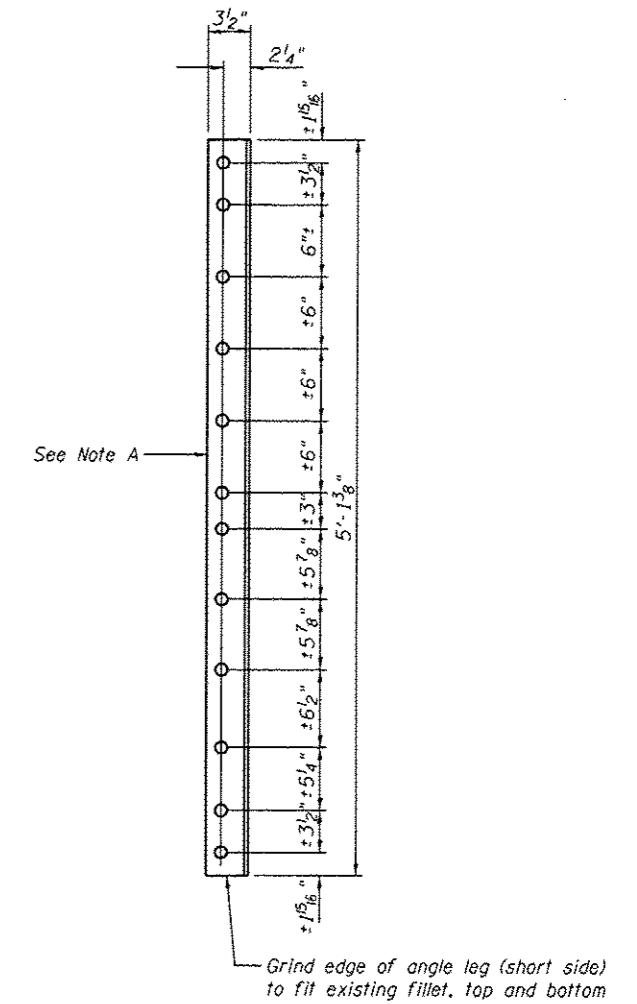

REPAIR ANGLE D6
L5x3 1/2 x 5/16 x 5'-1 3/8"

Note A:
Field drill holes using existing holes as template.
Remainder of holes may be shop or field drilled.

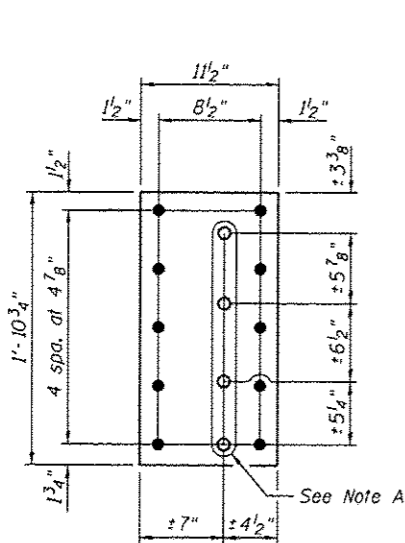

REPAIR R A6
R 3/8" x 11 1/2" x 1'-10 3/4"

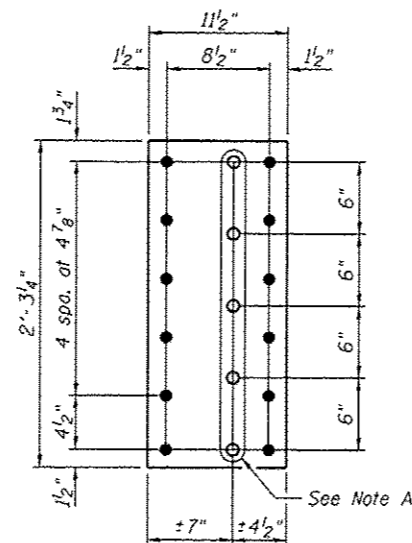

REPAIR R B6
R 3/8" x 11 1/2" x 2'-3 1/4"

Note:
See sheet S71 for additional repair and fill plate details.

BILL OF MATERIAL

Item	Unit	Total
Structural Steel Repair	Pound	480



USER NAME *	DESIGNED - PRC	REVISED
	CHECKED - CDB	REVISED
PLOT SCALE *	DRAWN - PRC	REVISED
PLOT DATE * 05/02/2014	CHECKED - CDB	REVISED

STATE OF ILLINOIS
DEPARTMENT OF TRANSPORTATION

MAIN SPANS FLOORBEAM WEB REPAIRS - 6
S.N. 082-6001 MLK BRIDGE OVER MISSISSIPPI RIVER

F.A.P. RTE.	SECTION	COUNTY	TOTAL SHEETS	SHEET NO.
799	IBR, DRS-2	ST. CLAIR	156	88
CONTRACT NO. 76B03				
[ILLINOIS] FED. AID PROJECT				

SHEET NO. 570 OF 5138 SHEETS

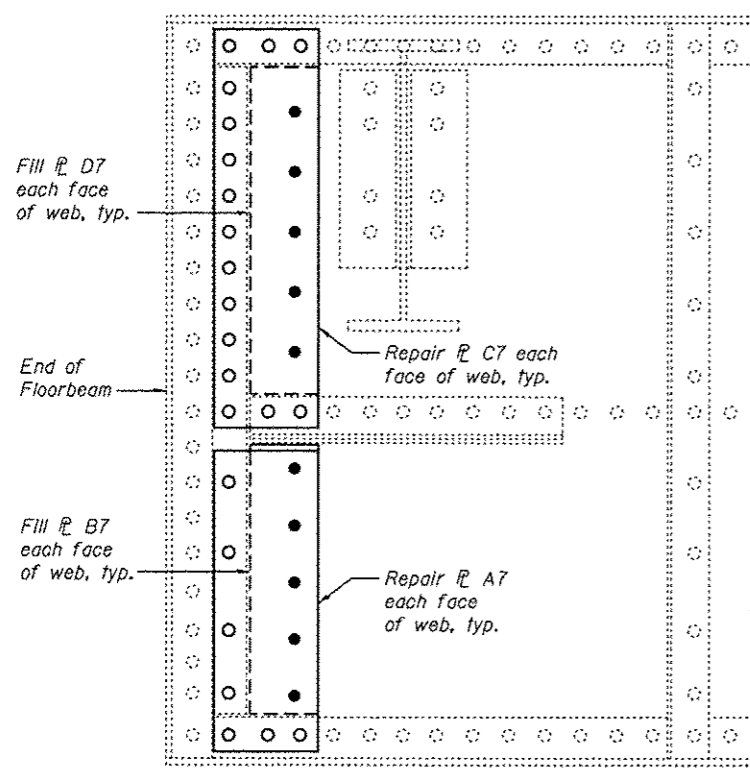

NORTH END AT PANEL POINT L16

West face shown
Span 10

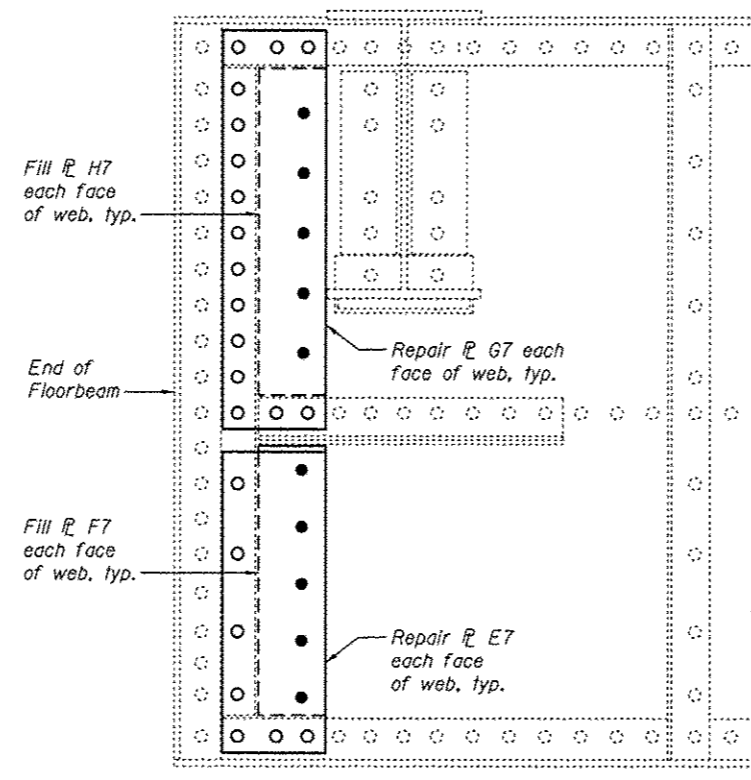

NORTH END AT PANEL POINT L19

West face shown
Span 10

FLOORBEAM WEB REPAIRS

Note A:
Field drill holes using existing holes as template.
Remainder of holes may be shop or field drilled.

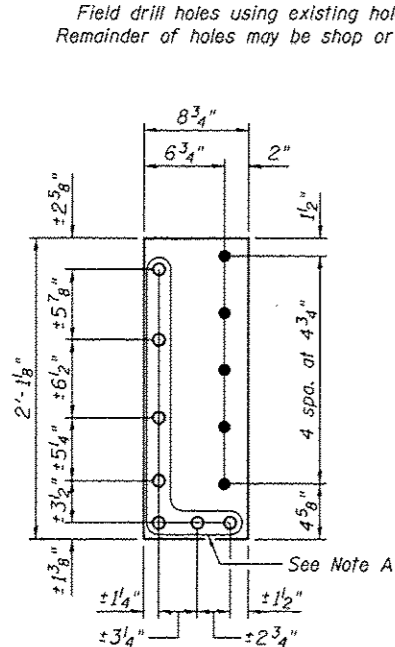

REPAIR P A7

P 3/8" x 8 3/4" x 2'-1 1/8"

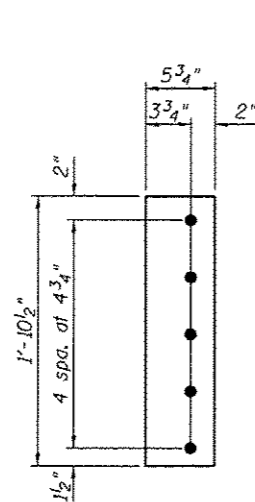

FILL P B7

P 9/16" x 5 3/4" x 1'-10 1/2"

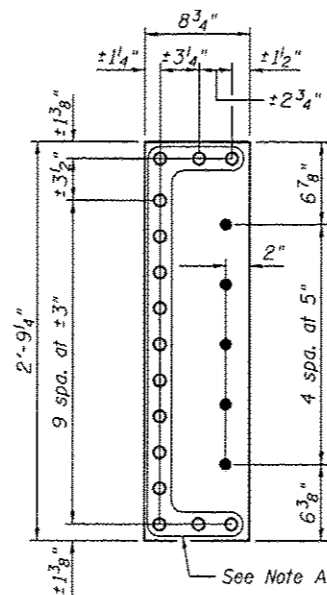

REPAIR P C7

P 3/8" x 8 3/4" x 2'-9 1/4"

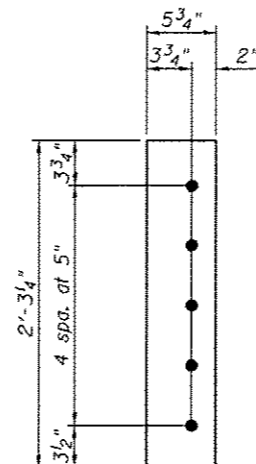

FILL P D7

P 9/16" x 5 3/4" x 2'-3 1/4"

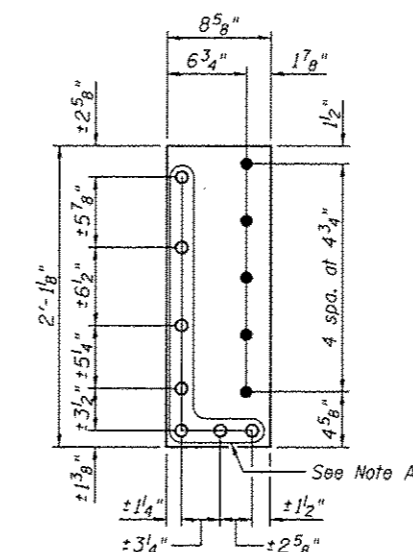

REPAIR P E7

P 3/8" x 8 5/8" x 2'-1 1/8"

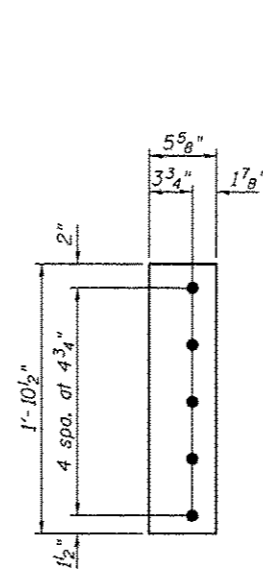

FILL P F7

P 9/16" x 5 5/8" x 1'-10 1/2"

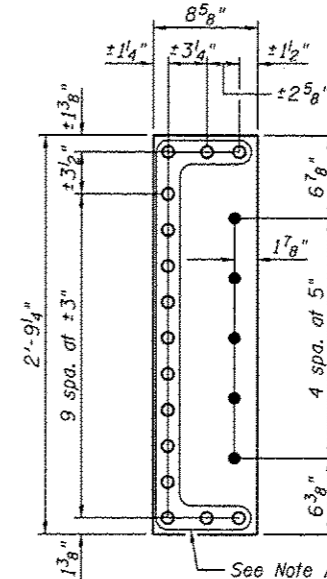

REPAIR P G7

P 3/8" x 8 5/8" x 2'-9 1/4"

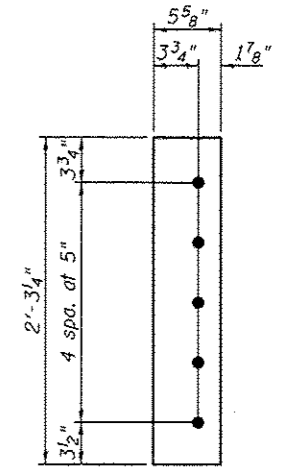

FILL P H7

P 9/16" x 5 5/8" x 2'-3 1/4"

BILL OF MATERIAL

Item	Unit	Total
Structural Steel Repair	Pound	460



USER NAME *	DESIGNED - PRC	REVISED
PLOT SCALE *	CHECKED - CDB	REVISED
PLOT DATE *	DRAWN - PRC	REVISED
03/28/2014	CHECKED - CDB	REVISED

STATE OF ILLINOIS
DEPARTMENT OF TRANSPORTATION

MAIN SPANS FLOORBEAM WEB REPAIRS - 7
S.N. 082-6001 MLK BRIDGE OVER MISSISSIPPI RIVER

SHEET NO. 571 OF 5138 SHEETS

F.A.P. RTE.	SECTION	COUNTY	TOTAL SHEETS	SHEET NO.
799	1BR, DRS-2	ST. CLAIR	156	89
CONTRACT NO. 76B03				
ILLINOIS FED. AID PROJECT				

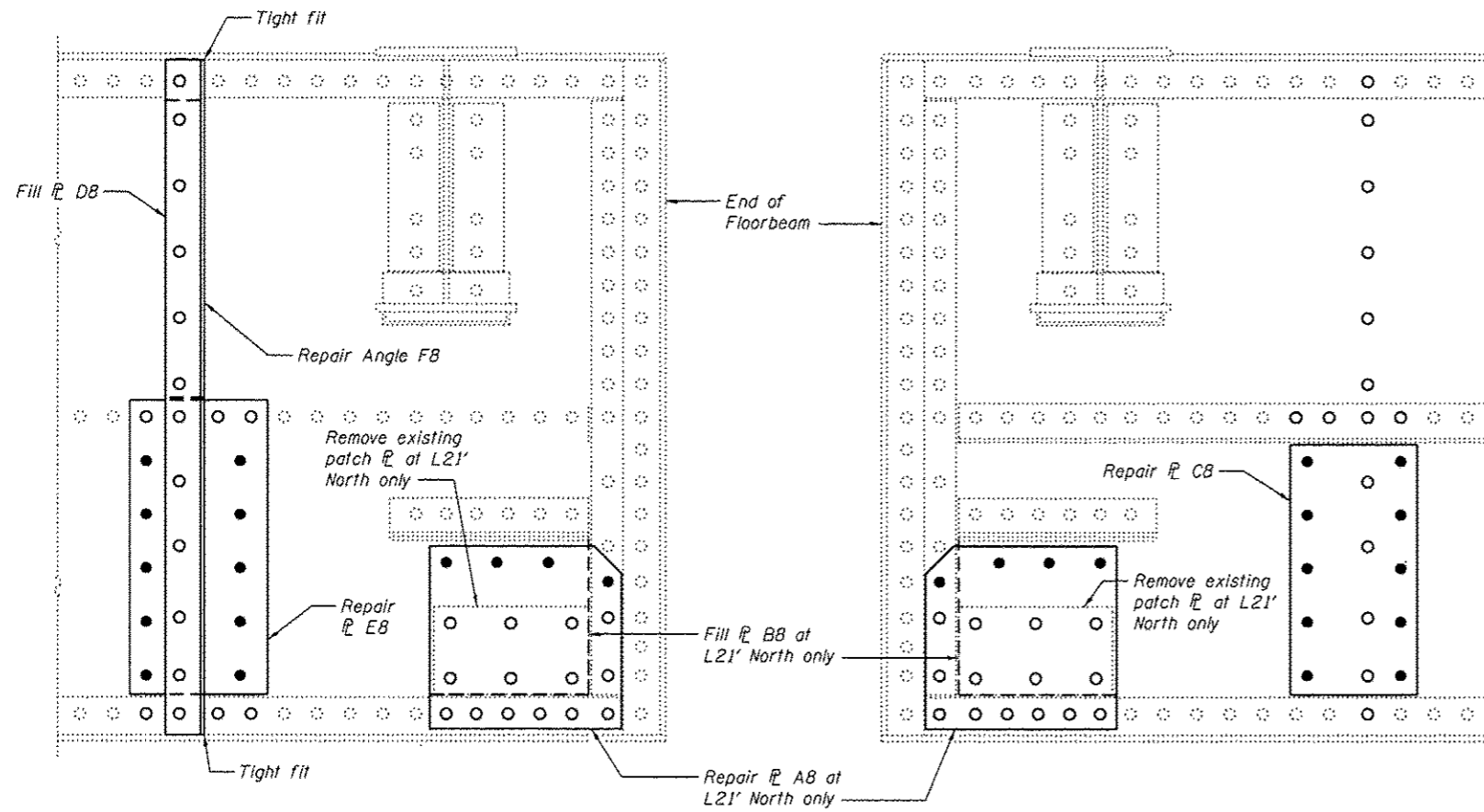

NORTH END AT PANEL POINT L21' AND L23'
EAST FACE
 (Span 10)

NORTH END AT PANEL POINT L21' AND L23'
WEST FACE
 (Span 10)

FLOORBEAM WEB REPAIRS

Note: L21' shown, L23' similar

Note A:
 Field drill holes using existing holes as template.
 Remainder of holes may be shop or field drilled.

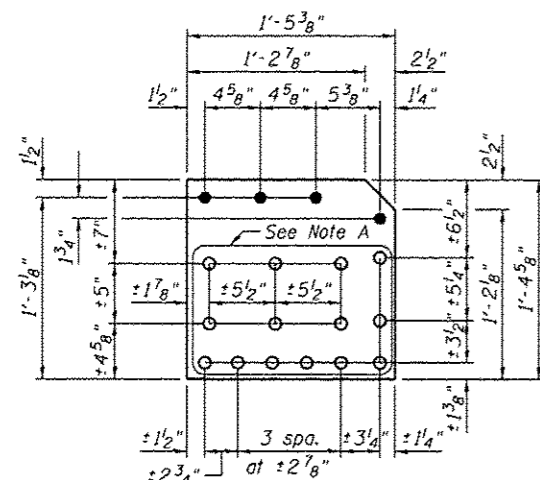

REPAIR P A8
 $R \frac{3}{8} \times 16 \frac{5}{8} \times 1'-5 \frac{3}{8}$

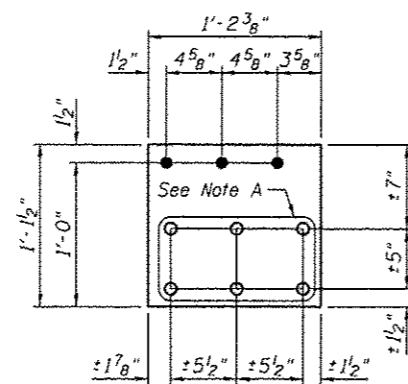

FILL P B8
 $R \frac{9}{16} \times 13 \frac{1}{2} \times 1'-2 \frac{3}{8}$

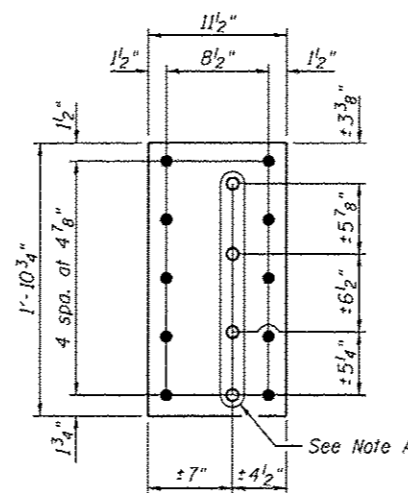

REPAIR P C8
 $R \frac{3}{8} \times 11 \frac{1}{2} \times 1'-10 \frac{3}{4}$

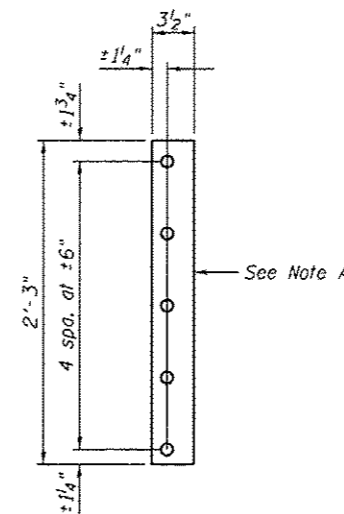

FILL P D8
 $R \frac{9}{16} \times 3 \frac{1}{2} \times 2'-3$

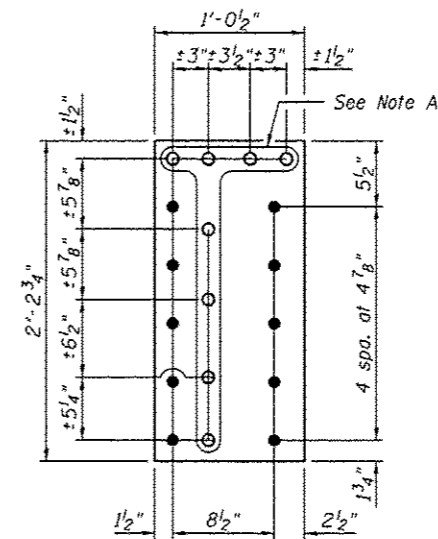

REPAIR P E8
 $R \frac{9}{16} \times 12 \frac{1}{2} \times 2'-2 \frac{3}{4}$

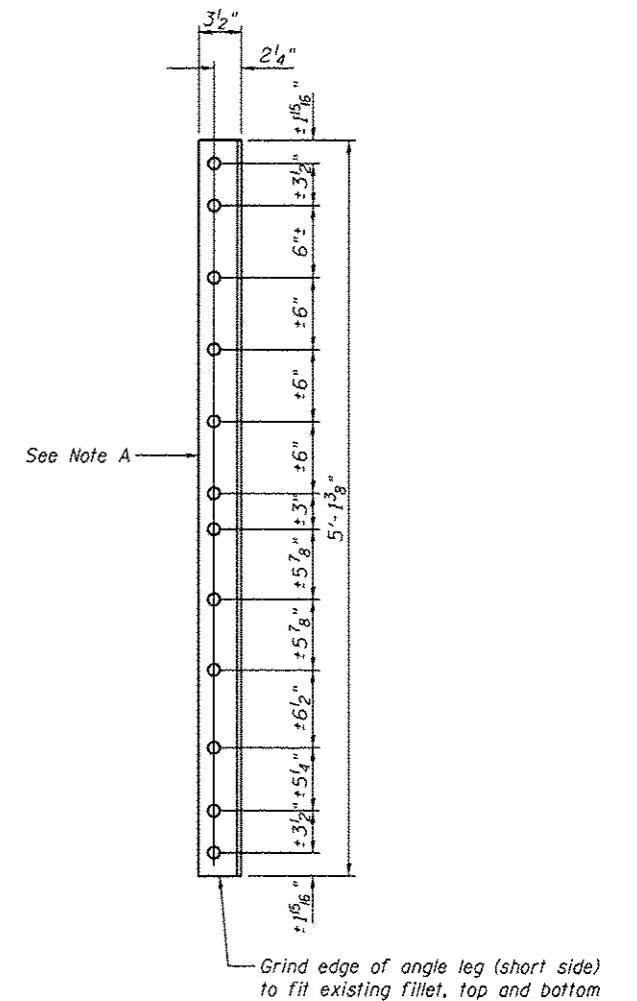

REPAIR ANGLE F8
 $L5x3 \frac{1}{2} \times 5 \frac{1}{8} \times 5'-1 \frac{3}{8}$

Grind edge of angle leg (short side) to fit existing fillet, top and bottom

BILL OF MATERIAL

Item	Unit	Total
Structural Steel Repair	Pound	480



USER NAME -	DESIGNED - PRC	REVISED
PLOT SCALE -	CHECKED - COB	REVISED
PLOT DATE - 05/02/2014	DRAWN - PRC	REVISED
	CHECKED - COB	REVISED

STATE OF ILLINOIS
 DEPARTMENT OF TRANSPORTATION

MAIN SPANS FLOORBEAM WEB REPAIRS - 8
 S.N. 082-6001 MLK BRIDGE OVER MISSISSIPPI RIVER

SHEET NO. 572 OF 5138 SHEETS

F.A.P. RTE. 799	SECTION 1BR. ORS-2	COUNTY ST. CLAIR	TOTAL SHEETS 156	SHEET NO. 90
			CONTRACT NO. 76B03	
(ILLINOIS) FED. AID PROJECT				

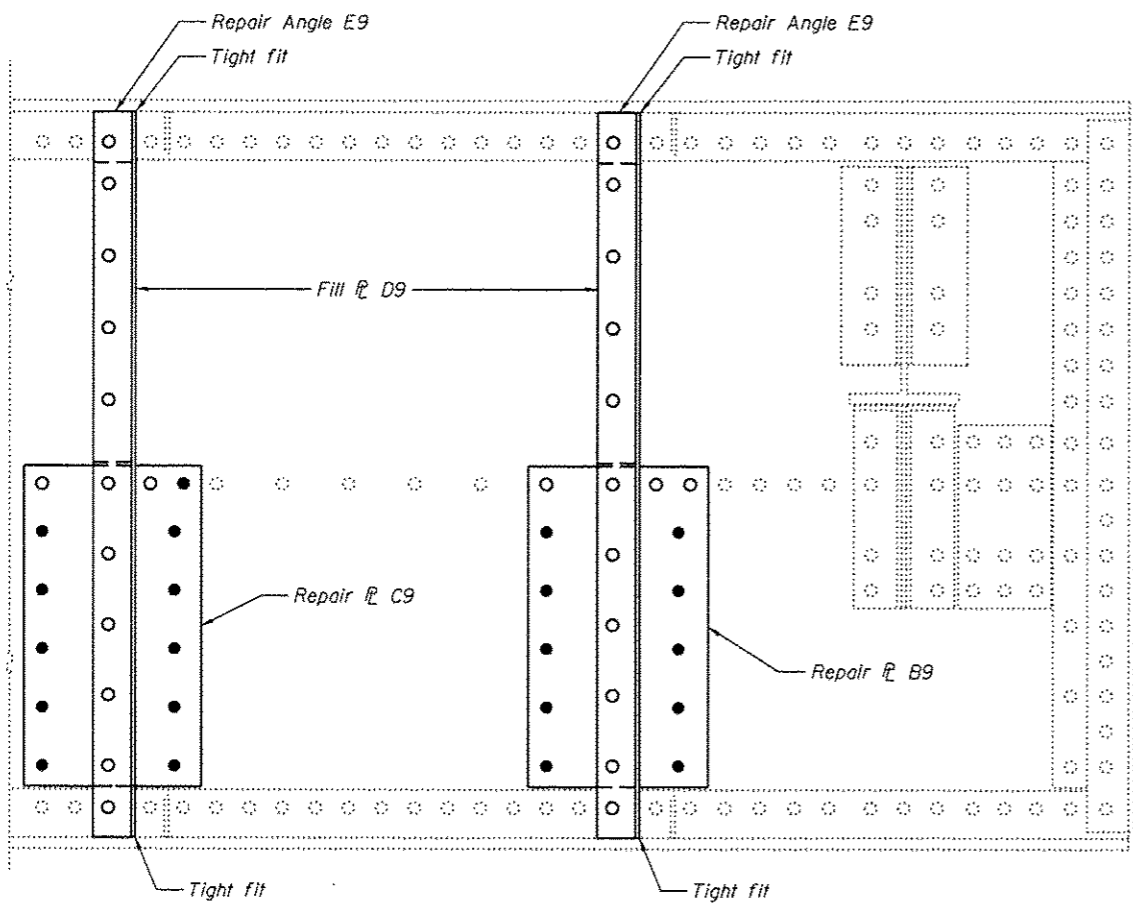

NORTH END AT PANEL POINT L11'
EAST FACE
(Span 11)

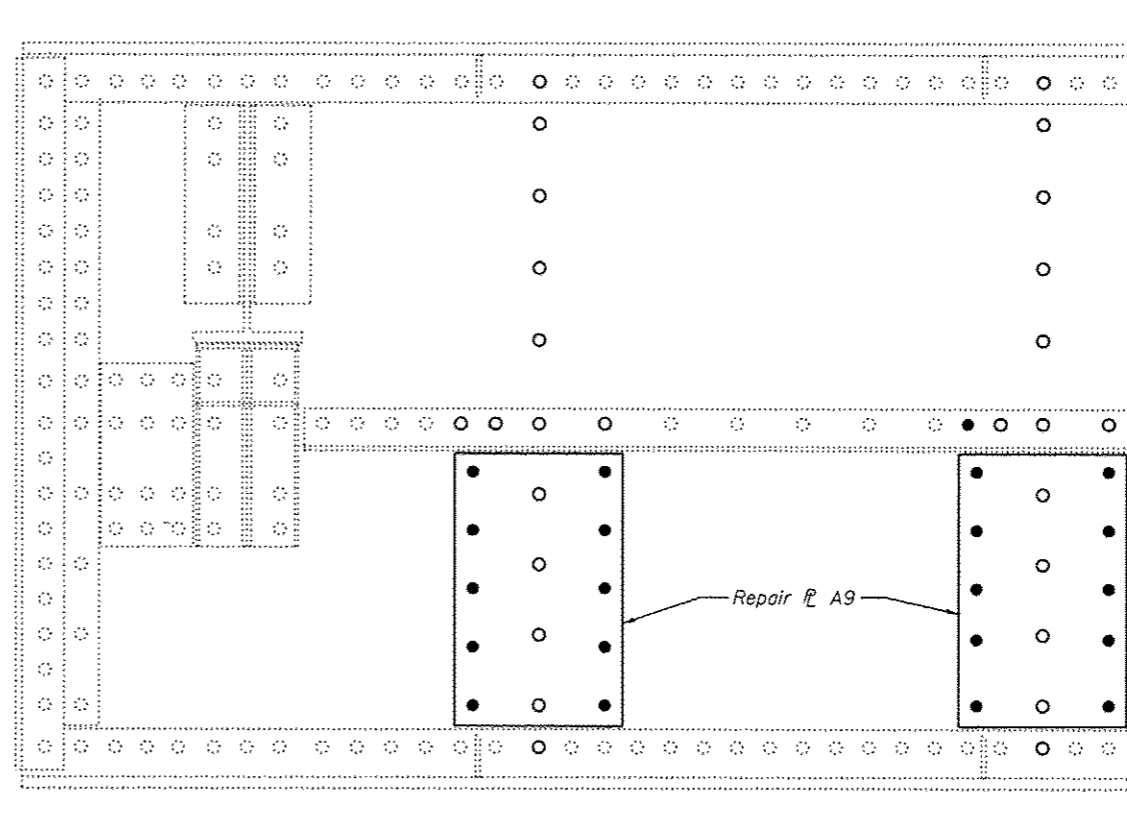

NORTH END AT PANEL POINT L11'
WEST FACE
(Span 11)

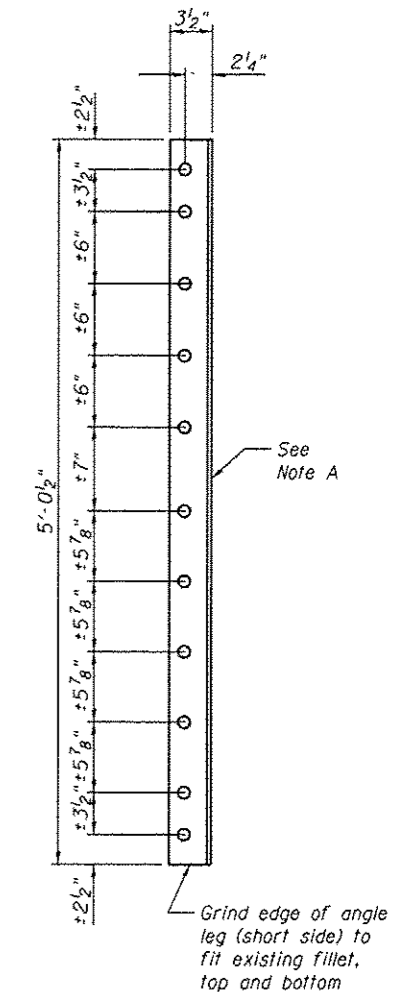

REPAIR ANGLE E9
L5x3 1/2x5/16 x 5'-0 1/2"

FLOORBEAM WEB REPAIRS

Note A:
Field drill holes using existing holes as template.
Remainder of holes may be shop or field drilled.

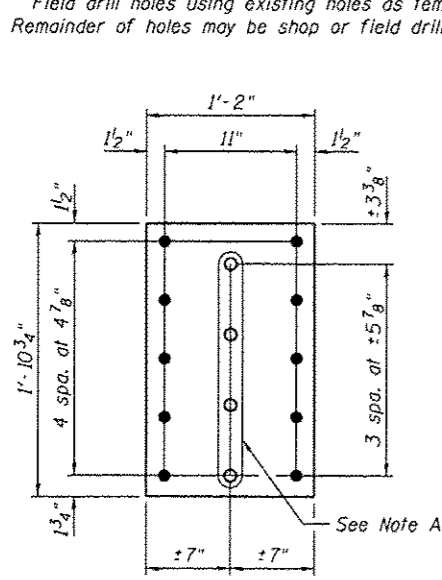

REPAIR P A9
P 3/8" x 14" x 1'-10 3/4"

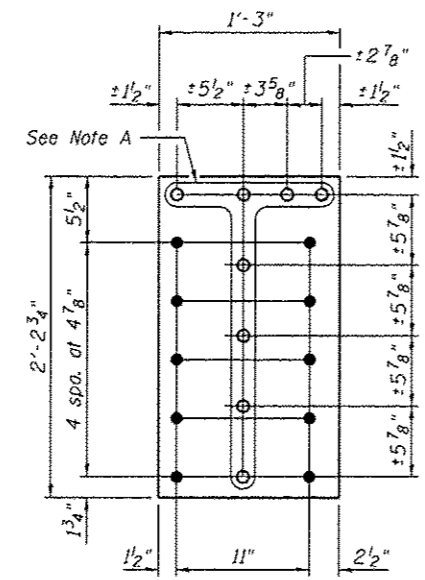

REPAIR P B9
P 5/8" x 15" x 2'-2 3/4"

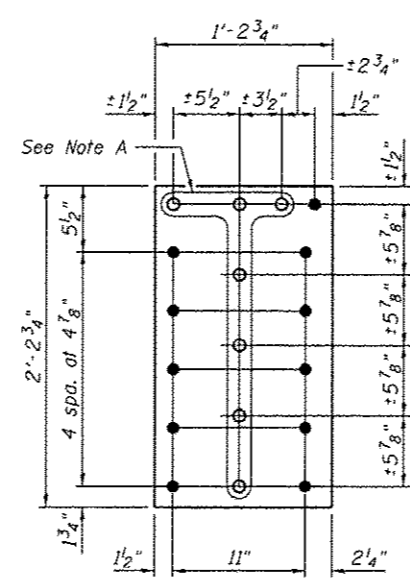

REPAIR P C9
P 5/8" x 14 3/4" x 2'-2 3/4"

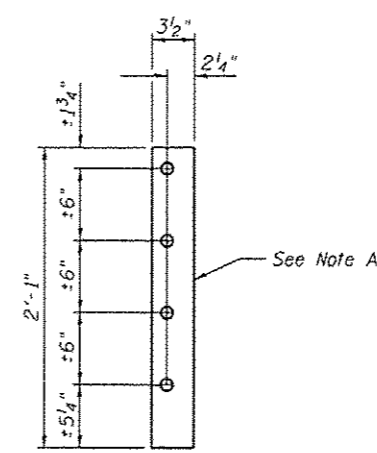

FILL P D9
P 5/8" x 3 1/2" x 2'-1"

BILL OF MATERIAL

Item	Unit	Total
Structural Steel Repair	Pound	380



USER NAME *	DESIGNED - PRC	REVISED
PLOT SCALE *	CHECKED - COB	REVISED
PLOT DATE = 05/02/2014	DRAWN - PRC	REVISED
	CHECKED - COB	REVISED

STATE OF ILLINOIS
DEPARTMENT OF TRANSPORTATION

MAIN SPANS FLOORBEAM WEB REPAIRS - 9
S.N. 082-6001 MLK BRIDGE OVER MISSISSIPPI RIVER

SHEET NO. 573 OF 5138 SHEETS

F.A.P. RTE.	SECTION	COUNTY	TOTAL SHEETS	SHEET NO.
799	1BR, ORS-2	ST. CLAIR	156	91
CONTRACT NO. 76803				
ILLINOIS FED. AID PROJECT				

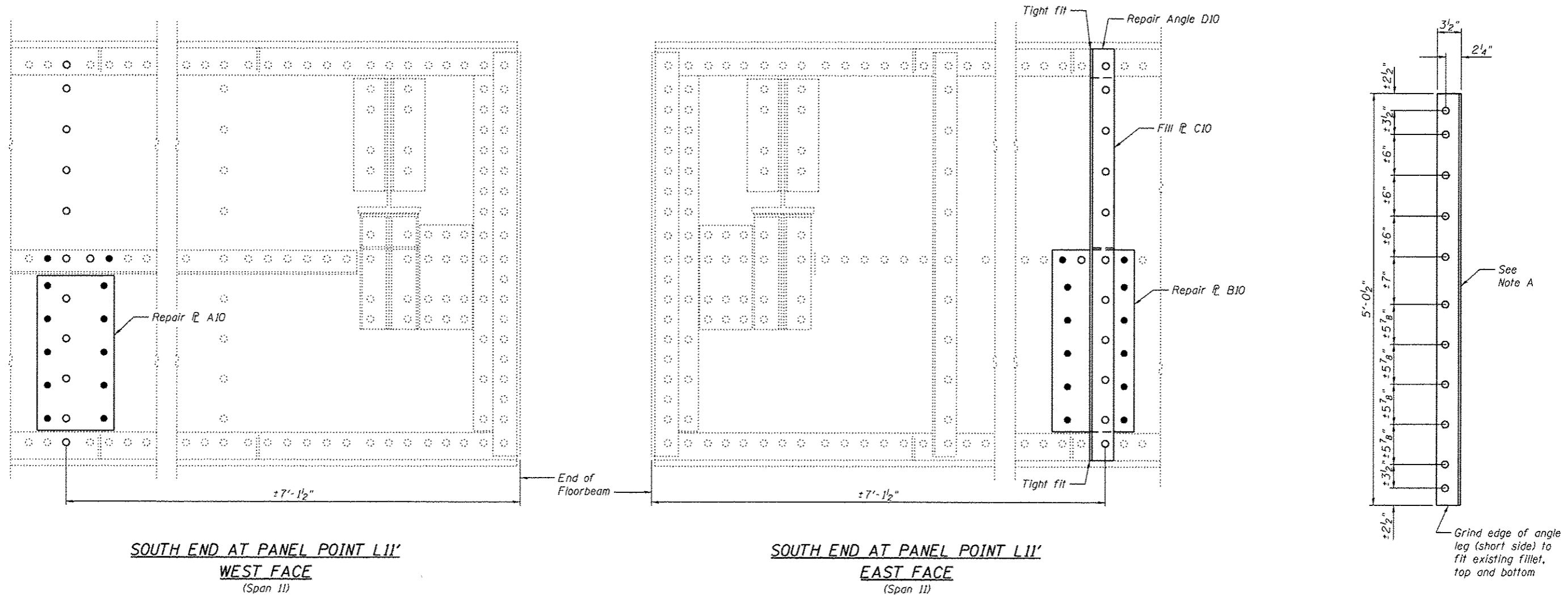

Note A:
Field drill holes using existing holes as template.
Remainder of holes may be shop or field drilled.

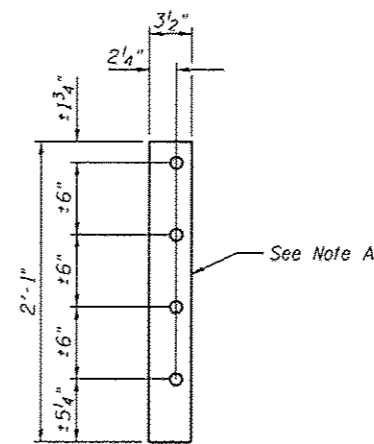
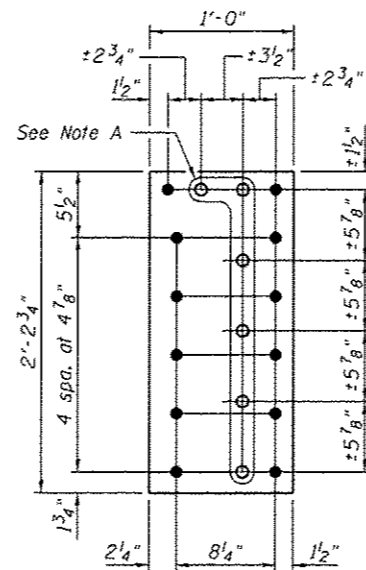
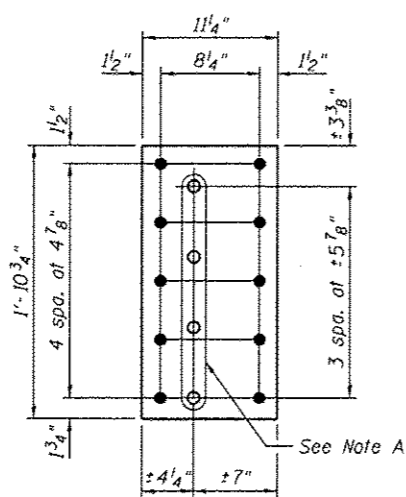

BILL OF MATERIAL

Item	Unit	Total
Structural Steel Repair	Pound	170

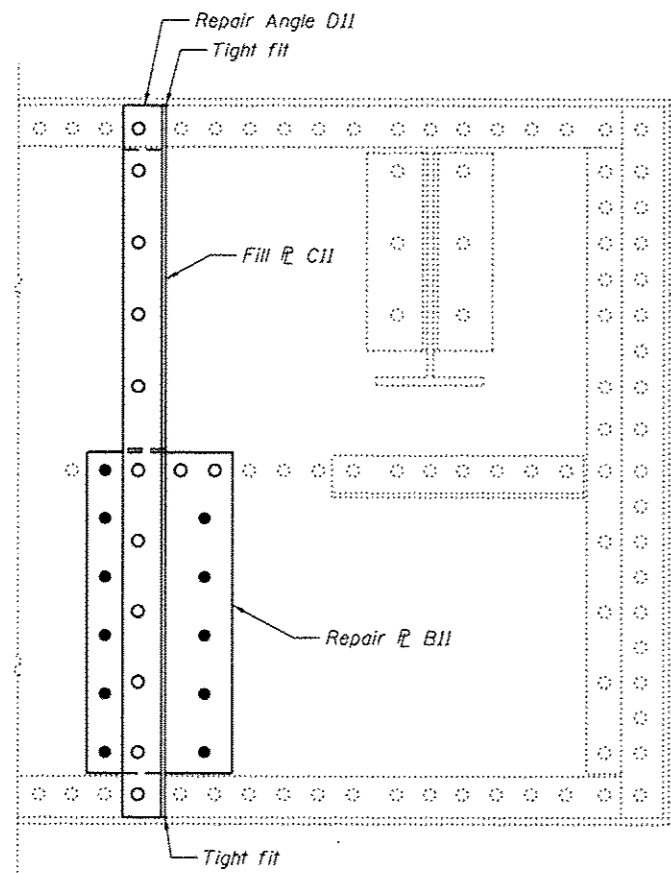

NORTH END AT PANEL POINT L9'
EAST FACE
(Span 11)

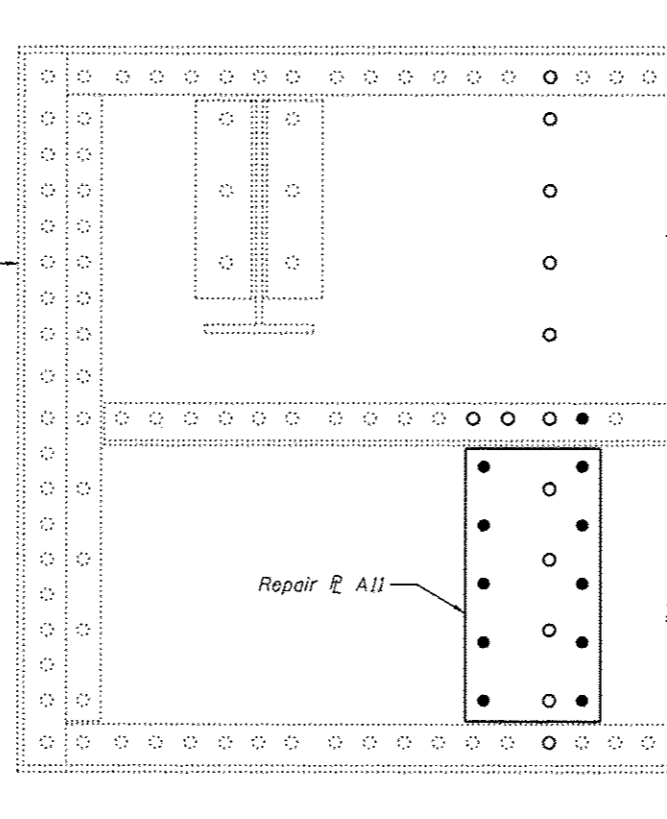

NORTH END AT PANEL POINT L9'
WEST FACE
(Span 11)

FLOORBEAM WEB REPAIRS

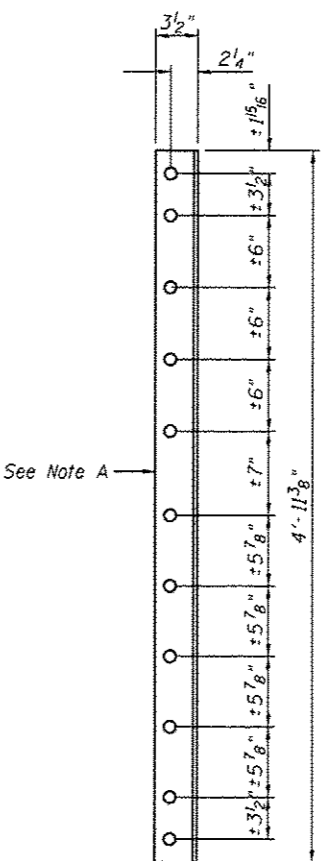

REPAIR ANGLE DII
L5x3 1/2 x 5/16 x 4'-11 3/8"

Grind edge of angle leg (short side) to fit existing fillet, top and bottom

Note A:
Field drill holes using existing holes as template.
Remainder of holes may be shop or field drilled.

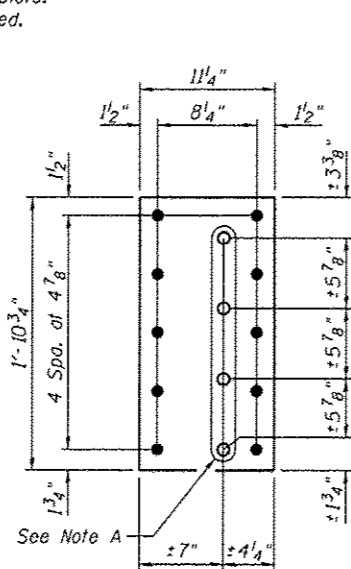

REPAIR P AII
P 3/8" x 11 1/4" x 1'-10 3/4"

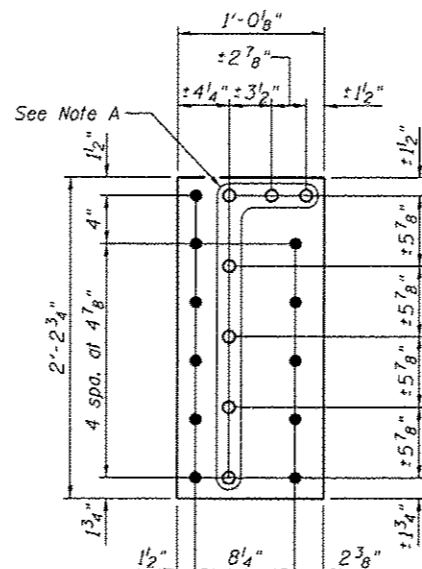

REPAIR P BII
P 9/16" x 12 1/8" x 2'-2 3/4"

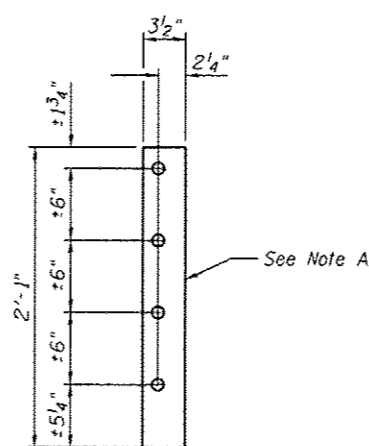

FILL P CII
P 9/16" x 3 1/2" x 2'-1"

BILL OF MATERIAL

Item	Unit	Total
Structural Steel Repair	Pound	160



USER NAME	DESIGNED - PRC	REVISED
	CHECKED - CDB	REVISED
PLOT SCALE	DRAWN - PRC	REVISED
PLOT DATE 05/02/2014	CHECKED - CDB	REVISED

STATE OF ILLINOIS
DEPARTMENT OF TRANSPORTATION

MAIN SPANS FLOORBEAM WEB REPAIRS - 11
S.N. 082-6001 MLK BRIDGE OVER MISSISSIPPI RIVER

SHEET NO. S75 OF 5138 SHEETS

F.A.P. RTE. 799	SECTION 1BR, DRS-2	COUNTY ST. CLAIR	TOTAL SHEETS 156	SHEET NO. 93
			CONTRACT NO. 76B03	
ILLINOIS FED. AID PROJECT				

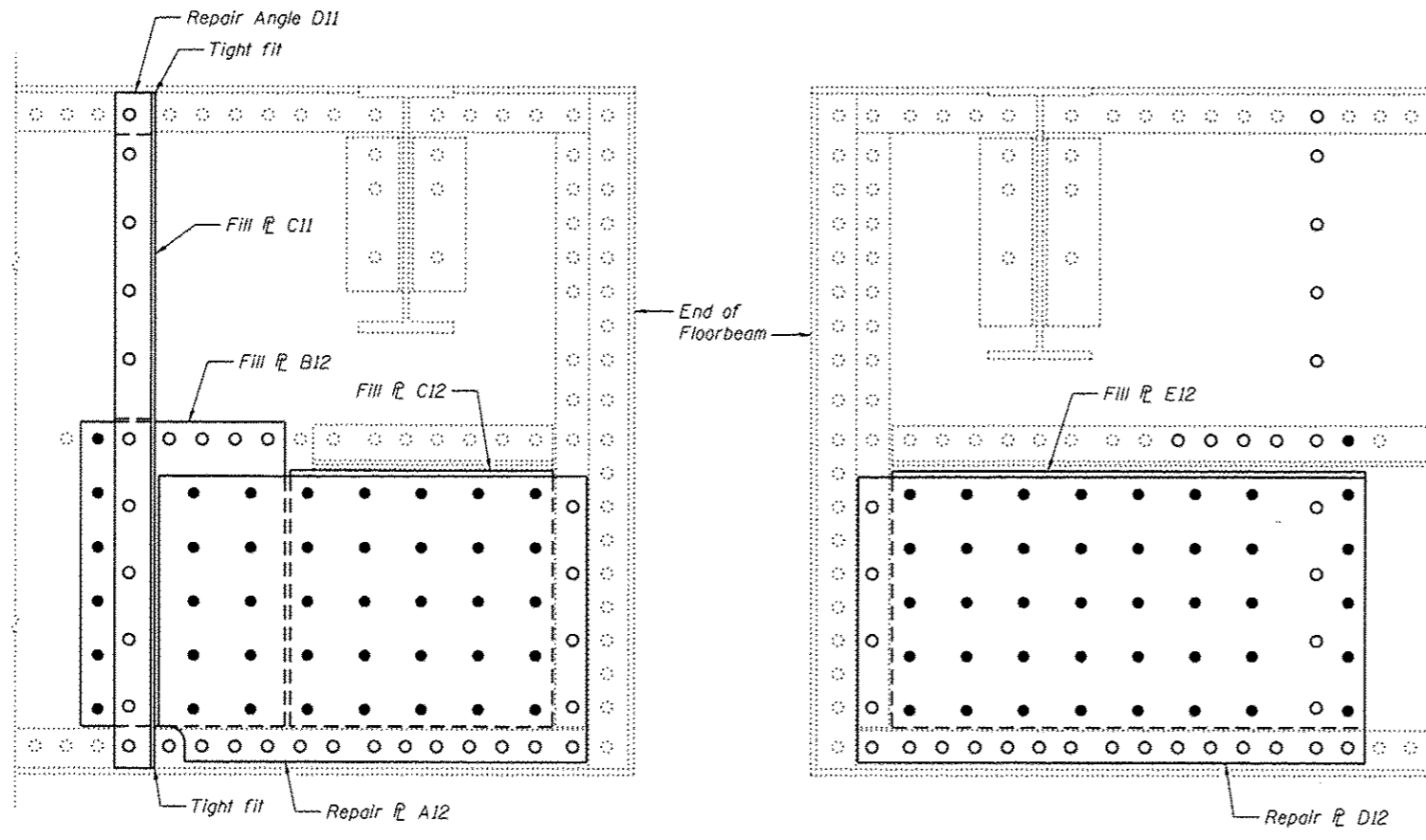

**NORTH END AT PANEL POINT L6'
EAST FACE**
(Span 11)

**NORTH END AT PANEL POINT L6'
WEST FACE**
(Span 11)

FLOORBEAM WEB REPAIRS

Note A:
Field drill holes using existing holes as template.
Remainder of holes may be shop or field drilled.

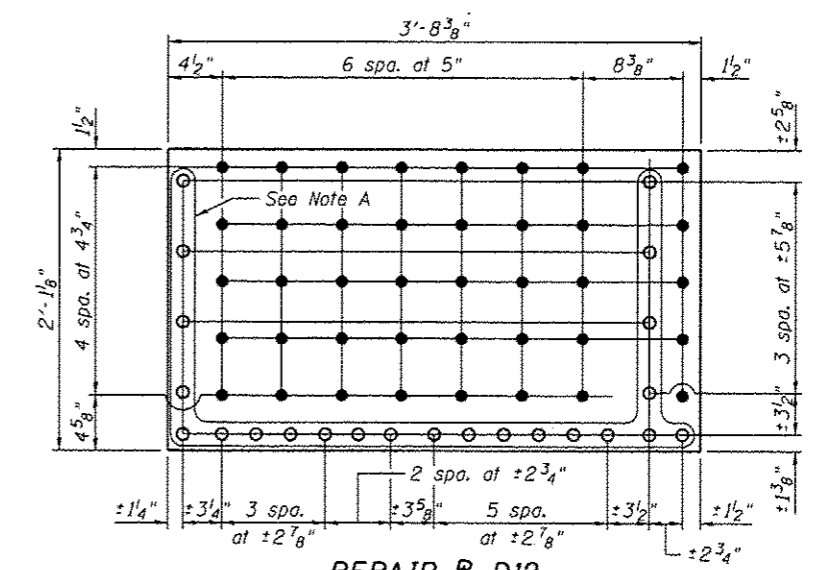

REPAIR P D12
R 3/8" x 25 1/8" x 3'-8 3/8"

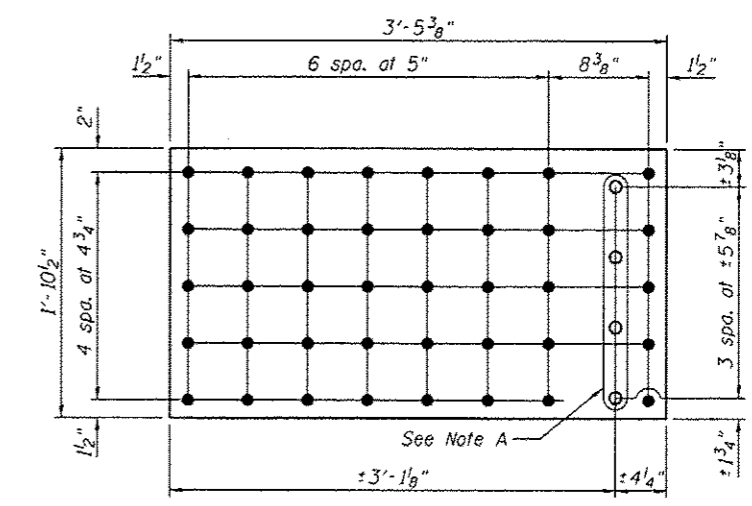

FILL P E12
R 9/16" x 22 1/2" x 3'-5 3/8"

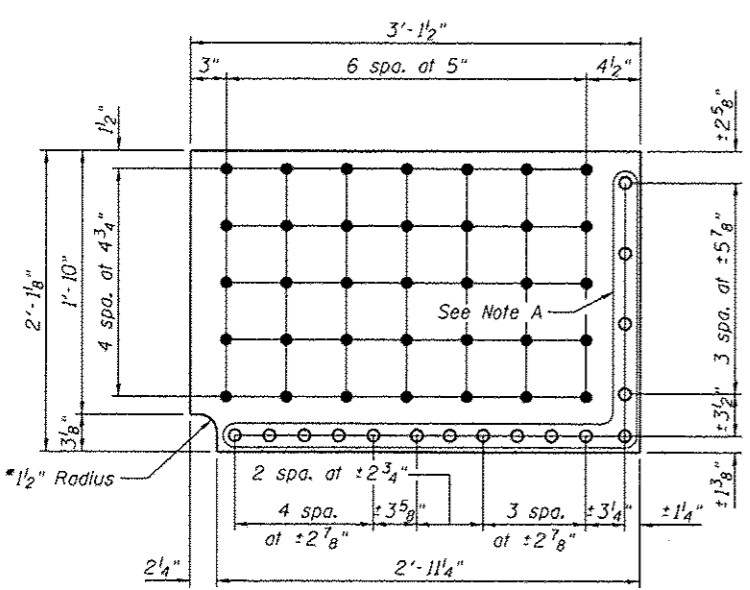

REPAIR P A12
R 3/8" x 25 1/8" x 3'-1 1/2"

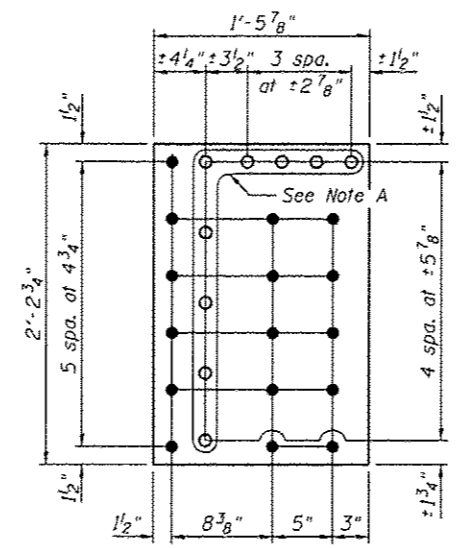

FILL P B12
R 9/16" x 17 7/8" x 2'-2 3/4"

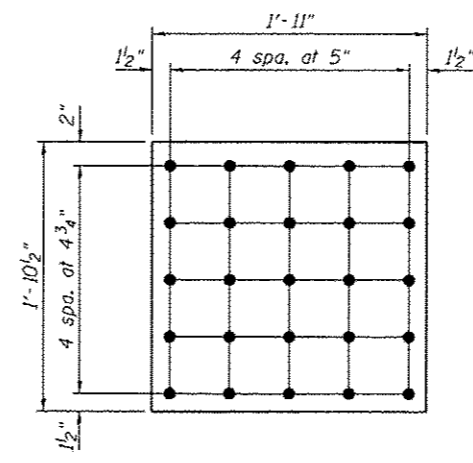

FILL P C12
R 9/16" x 22 1/2" x 1'-11"

Note:
See sheet S75 for additional repair angle and fill plate details.

BILL OF MATERIAL

Item	Unit	Total
Structural Steel Repair	Pound	660



USER NAME *	DESIGNED - PRC	REVISIONS
	CHECKED - COB	REVISIONS
PLOT SCALE *	DRAWN - PRC	REVISIONS
PLOT DATE * 05/02/2014	CHECKED - COB	REVISIONS

**STATE OF ILLINOIS
DEPARTMENT OF TRANSPORTATION**

**MAIN SPANS FLOORBEAM WEB REPAIRS - 12
S.N. 082-6001 MLK BRIDGE OVER MISSISSIPPI RIVER**

F.A.P. RTE. 799	SECTION IBR, ORS-2	COUNTY ST. CLAIR	TOTAL SHEETS 156	SHEET NO. 94
SHEET NO. S76 OF S138 SHEETS			CONTRACT NO. 76B03	
ILLINOIS FED. AID PROJECT				

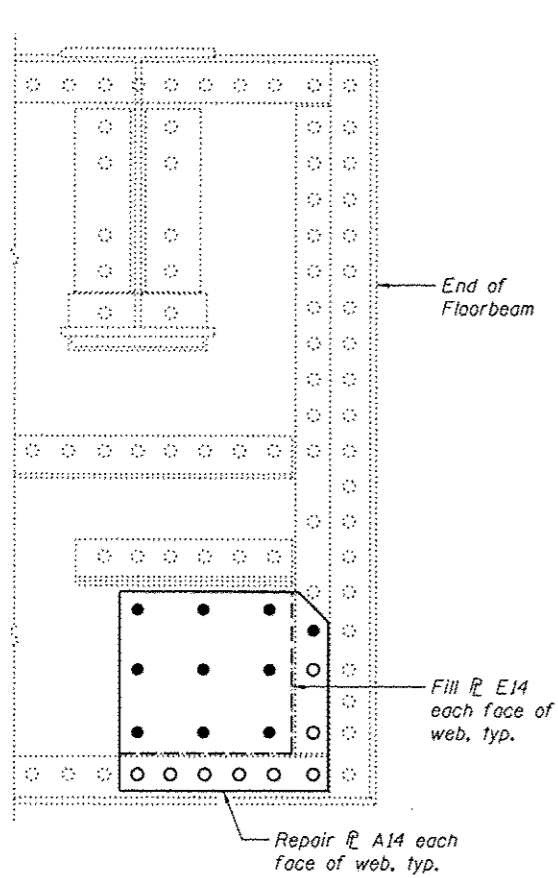

NORTH END AT PANEL POINT L21
East face shown
(Span 10)

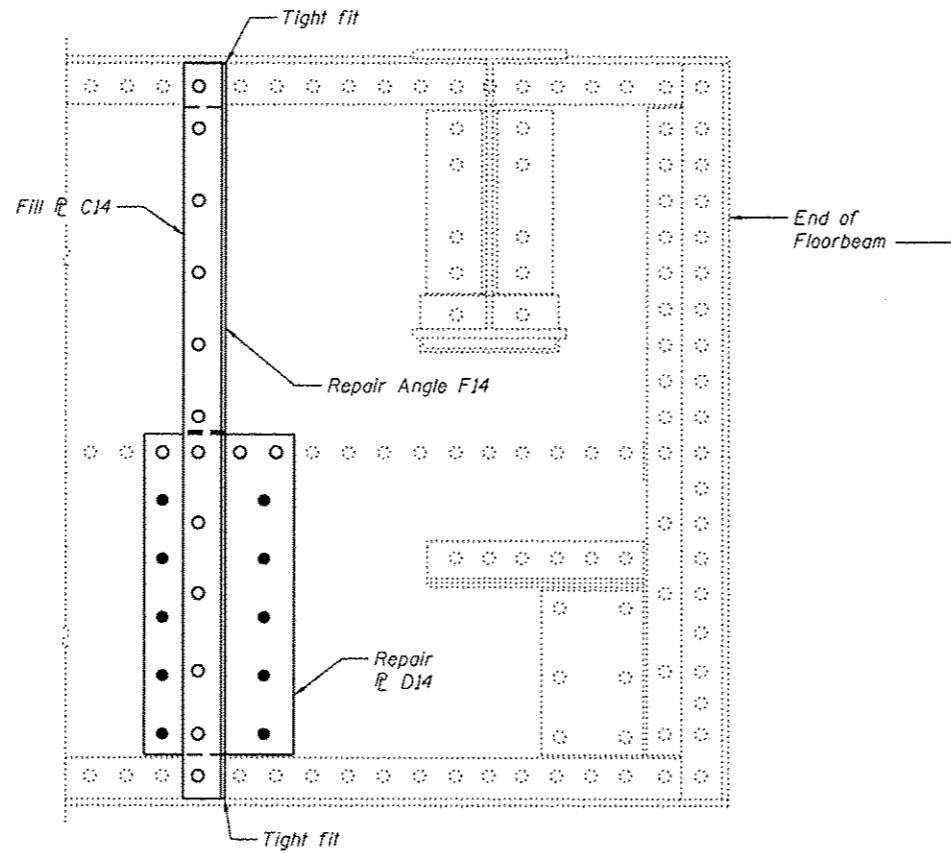

SOUTH END AT PANEL POINT L21
WEST FACE
(Span 10)

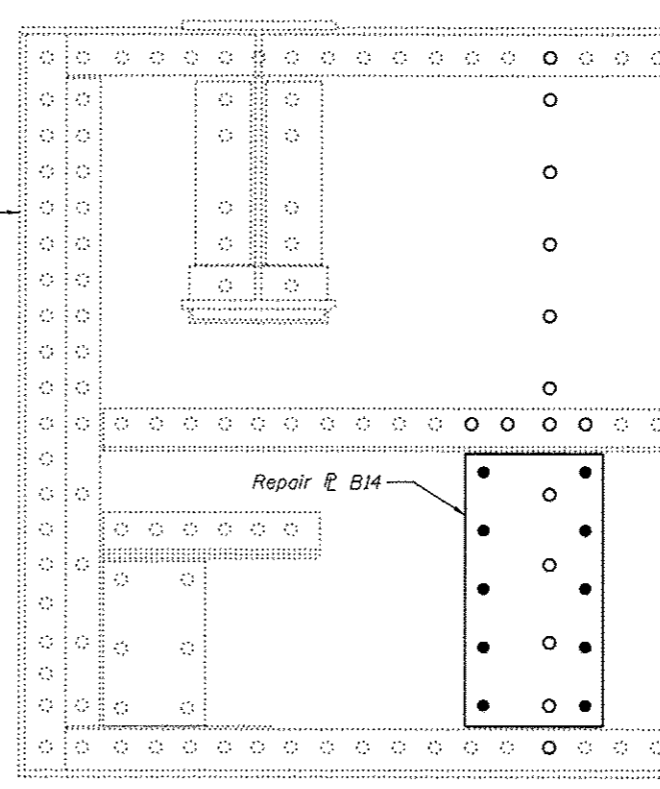

SOUTH END AT PANEL POINT L21
EAST FACE
(Span 10)

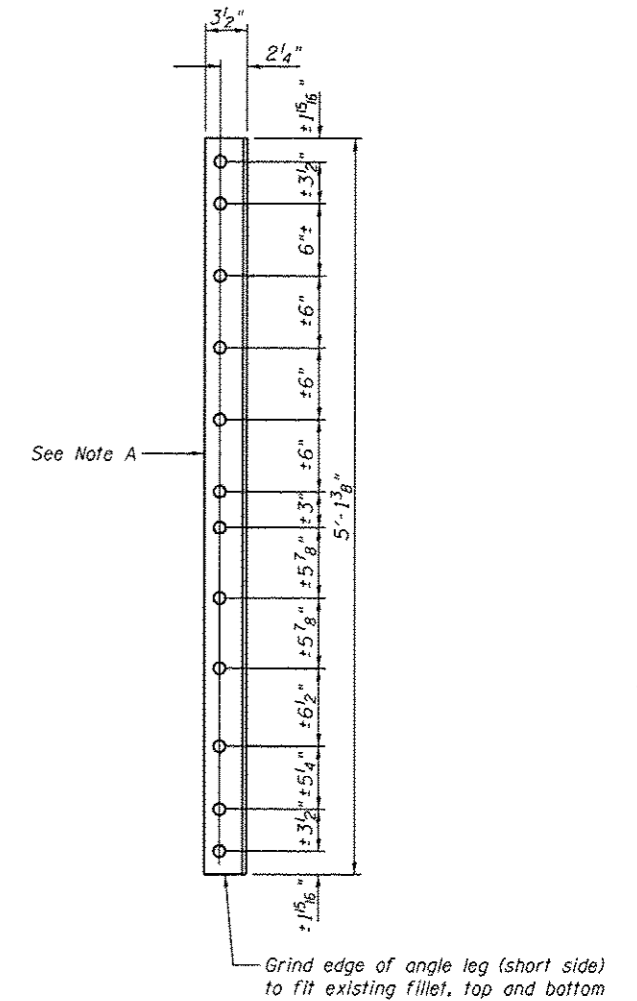

REPAIR ANGLE F14
L5x3 $\frac{1}{2}$ x $\frac{5}{16}$ x 5'-1 $\frac{3}{8}$ "

FLOORBEAM WEB REPAIRS

Note A:
Field drill holes using existing holes as template.
Remainder of holes may be shop or field drilled.

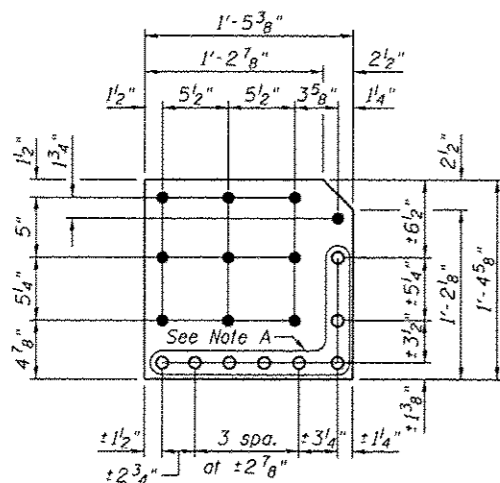

REPAIR R A14
R $\frac{3}{8}$ " x 16 $\frac{5}{8}$ " x 1'-5 $\frac{3}{8}$ "

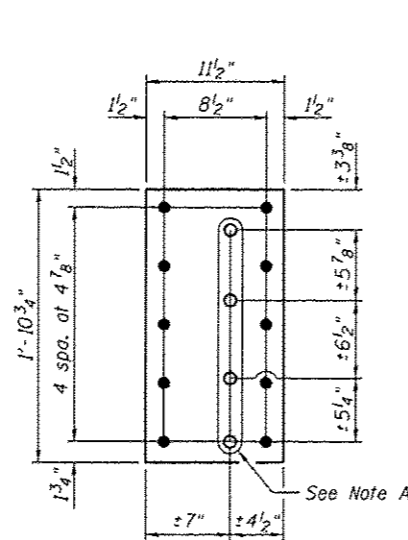

REPAIR R B14
R $\frac{3}{8}$ " x 11 $\frac{1}{2}$ " x 1'-10 $\frac{3}{4}$ "

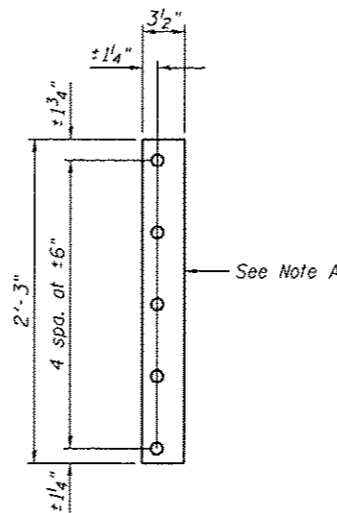

FILL R C14
R $\frac{9}{16}$ " x 3 $\frac{1}{2}$ " x 2'-3"

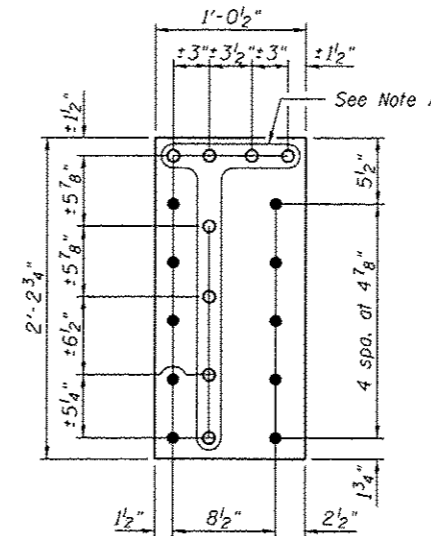

REPAIR R D14
R $\frac{9}{16}$ " x 12 $\frac{1}{2}$ " x 2'-2 $\frac{3}{4}$ "

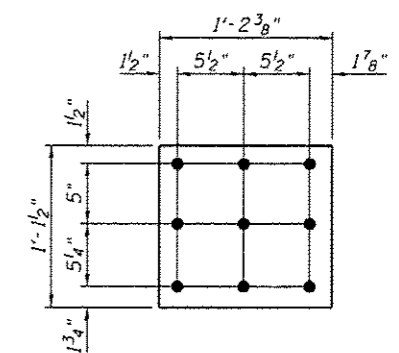

FILL R E14
R $\frac{9}{16}$ " x 13 $\frac{1}{2}$ " x 1'-2 $\frac{3}{8}$ "

BILL OF MATERIAL

Item	Unit	Total
Structural Steel Repair	Pound	310



USER NAME	DESIGNED - PRC
PLLOT SCALE	CHECKED - CDB
PLLOT DATE	DRAWN - PRC
	CHECKED - CDB

REVISIED
REVISIED
REVISIED
REVISIED

STATE OF ILLINOIS
DEPARTMENT OF TRANSPORTATION

MAIN SPANS FLOORBEAM WEB REPAIRS - 14
S.N. 082-6001 MLK BRIDGE OVER MISSISSIPPI RIVER

SHEET NO. 578 OF 5138 SHEETS

F.A.P. RTE. 799	SECTION 1BR, DRS-2	COUNTY ST. CLAIR	TOTAL SHEETS 156	SHEET NO. 96
ILLINOIS FED. AID PROJECT			CONTRACT NO. 76B03	

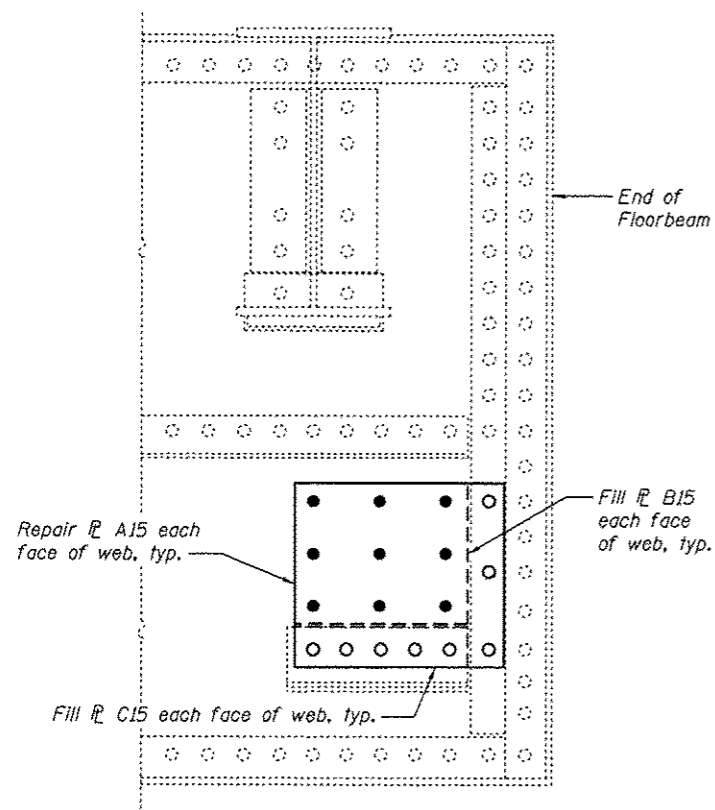

NORTH END AT PANEL POINT L24

East face shown
(Span 10)

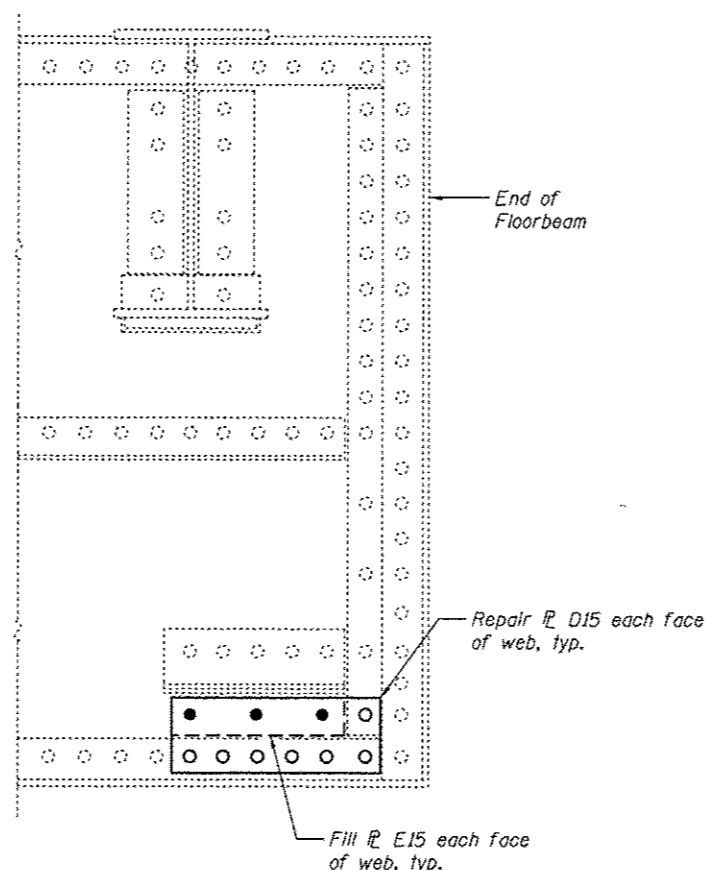

SOUTH END AT PANEL POINT L23*

West face shown
(Span 10)

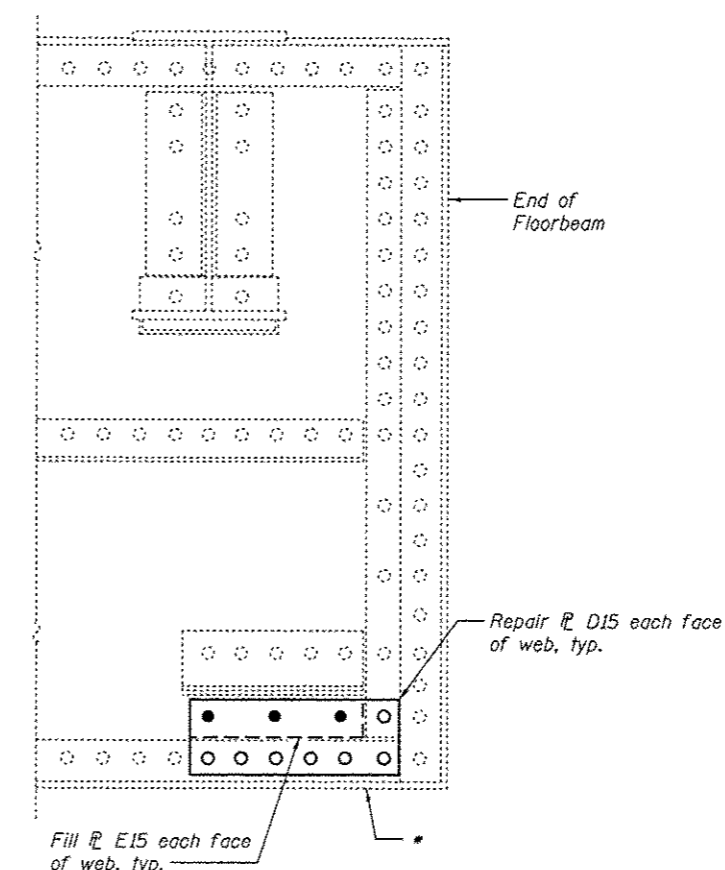

NORTH END AT PANEL POINT L23

East face shown
(Span 10)

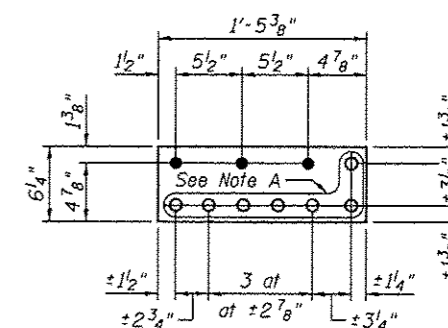

REPAIR P D15

P 3/8" x 6 1/4" x 1'-5 3/8"

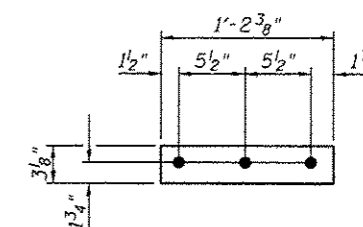

FILL P E15

P 9/16" x 3 1/8" x 1'-2 3/8"

FLOORBEAM WEB REPAIRS

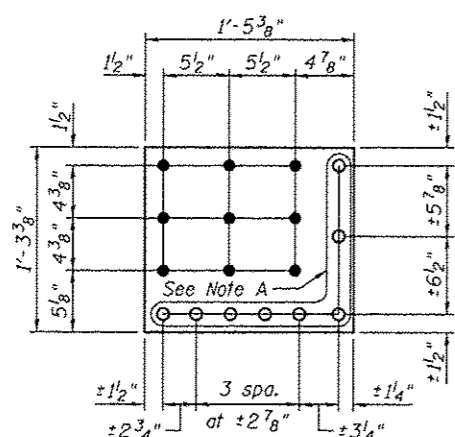

REPAIR P A15

P 3/8" x 1 5/8" x 1'-5 3/8"

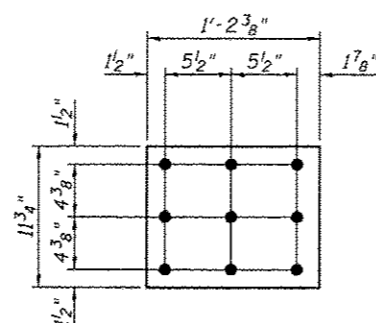

FILL P B15

P 9/16" x 1 1/4" x 1'-2 3/8"

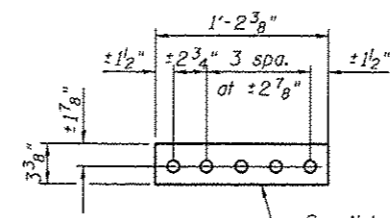

FILL P C15

P 3/16" x 3 3/8" x 1'-2 3/8"

* Remove delamination from bottom angle of floorbeam 23, north end. Grind smooth to an ANSI 250 finish. Cost included with Structural Steel Repair.

Note A:
Field drill holes using existing holes as template. Remainder of holes may be shop or field drilled.

BILL OF MATERIAL

Item	Unit	Total
Structural Steel Repair	Pound	230



USER NAME :	DESIGNED - PRC	REVISED
PLOT SCALE :	CHECKED - CDB	REVISED
PLOT DATE :	DRAWN - PRC	REVISED
	CHECKED - CDB	REVISED

STATE OF ILLINOIS
DEPARTMENT OF TRANSPORTATION

MAIN SPANS FLOORBEAM WEB REPAIRS - 15
S.N. 082-6001 MLK BRIDGE OVER MISSISSIPPI RIVER

SHEET NO. 579 OF 5138 SHEETS

F.A.P. RTE.	SECTION	COUNTY	TOTAL SHEETS	SHEET NO.
799	IBR, DRS-2	ST. CLAIR	156	97
CONTRACT NO. 76B03				
[ILLINOIS] FED. AID PROJECT				

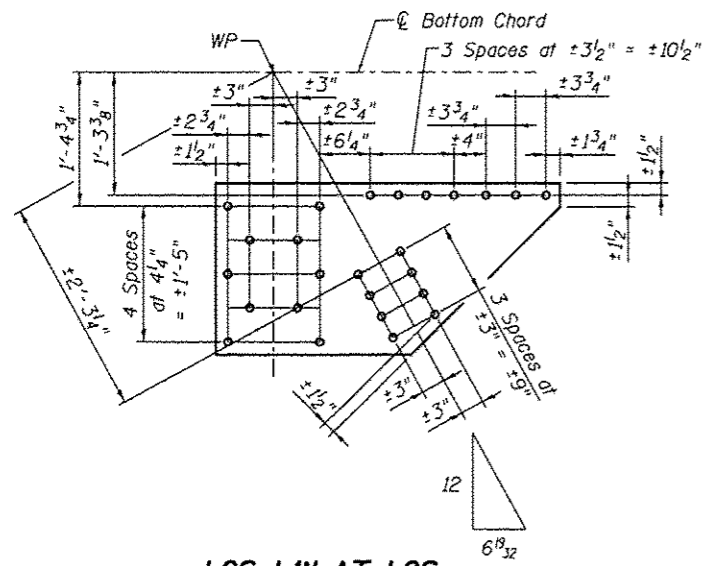

LOS-LIN AT LOS

$\mathbb{R} \frac{3}{8} \times 21\frac{1}{2} \times 3'-7"$

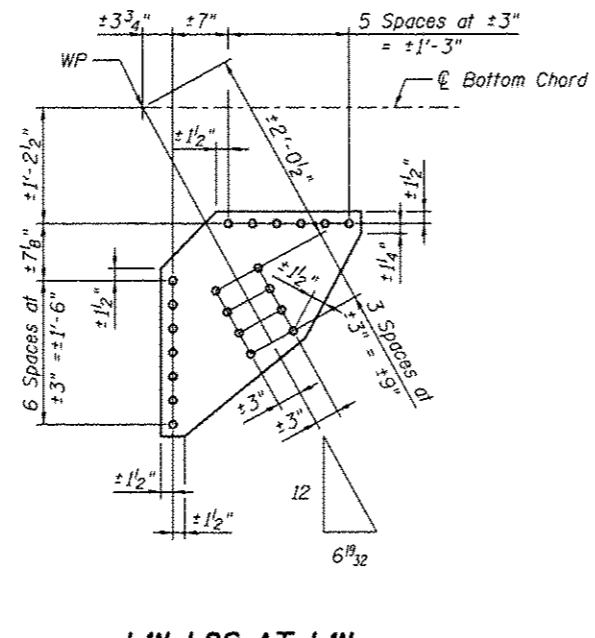

LIN-L2S AT LIN

$\mathbb{R} \frac{3}{8} \times 28\frac{1}{4} \times 2'-1"$

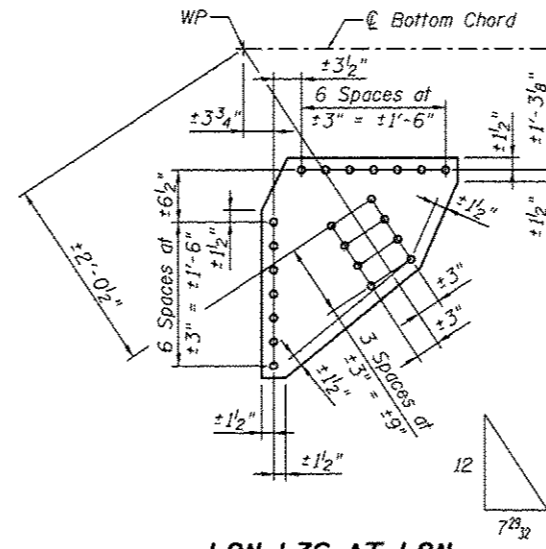

L2N-L3S AT L2N

$\mathbb{R} \frac{3}{8} \times 27\frac{1}{2} \times 2'-0\frac{1}{2}"$

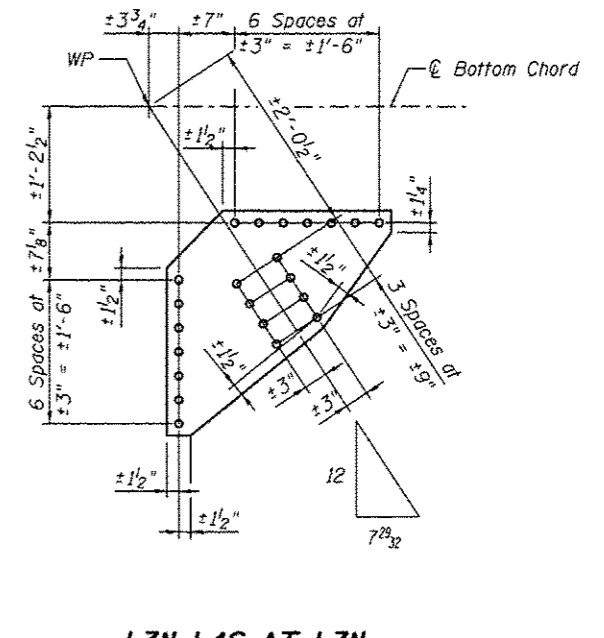

L3N-L4S AT L3N

$\mathbb{R} \frac{3}{8} \times 28\frac{1}{4} \times 2'-4"$

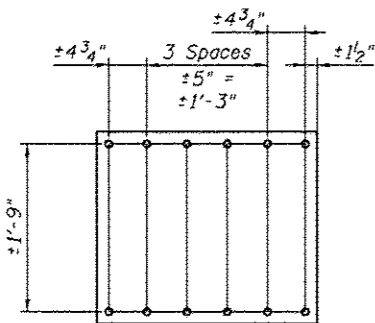

L4N-L5S AT L5S

L5N-L6S AT L6S

$\mathbb{R} \frac{3}{8} \times 27\frac{1}{2} \times 2'-0"$

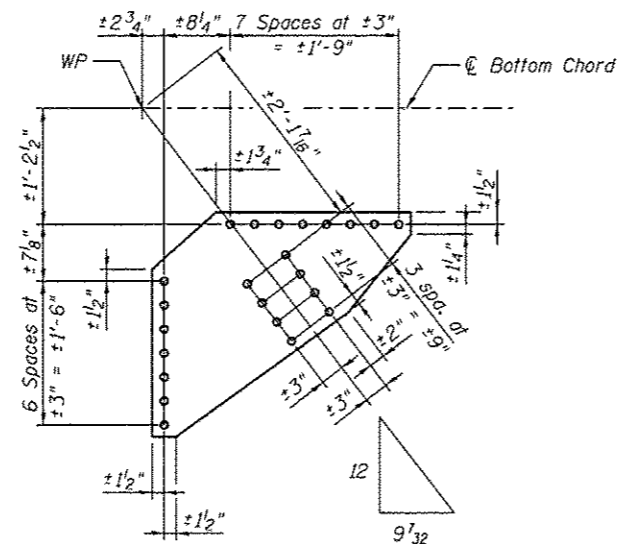

L6N-L7S AT L7S

$\mathbb{R} \frac{3}{8} \times 28\frac{1}{4} \times 2'-8\frac{1}{2}"$

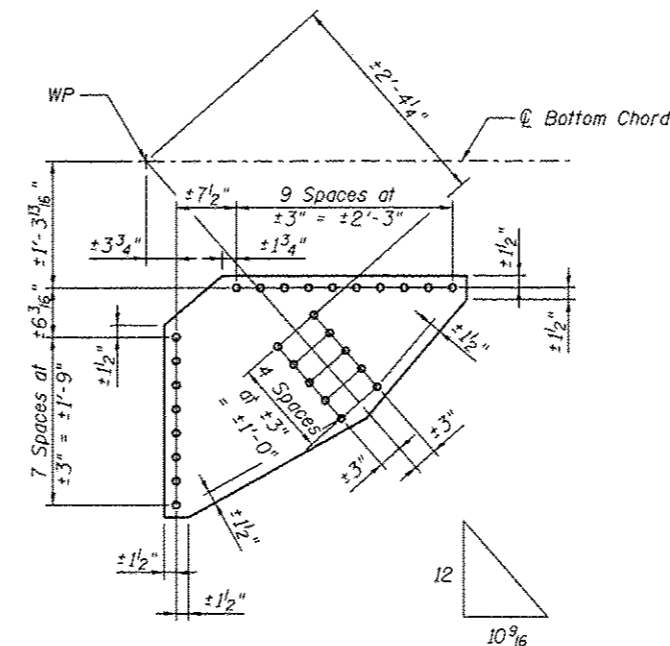

L10S-L11N AT L10S

$\mathbb{R} \frac{3}{8} \times 30\frac{1}{4} \times 3'-1\frac{3}{4}"$

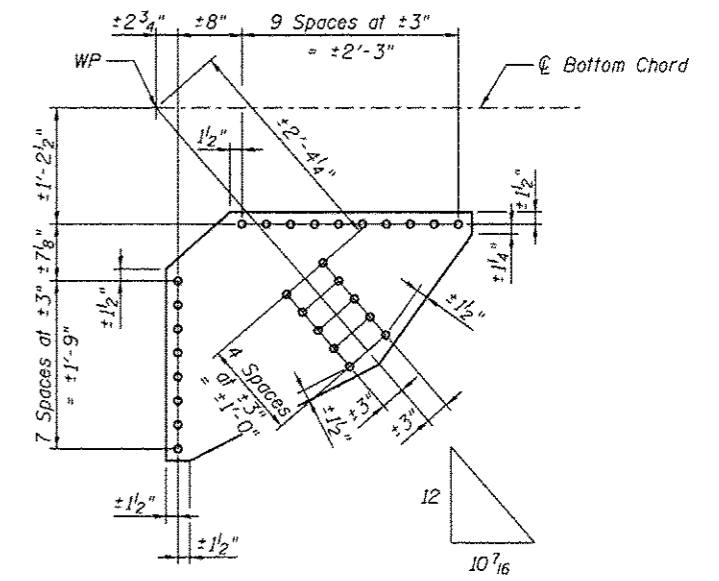

L12N-L13S AT L13S

$\mathbb{R} \frac{3}{8} \times 31\frac{1}{4} \times 3'-2"$

BILL OF MATERIAL

Item	Unit	Total
Structural Steel Repair	Pound	760

Note:
Field drill holes using existing holes as template.



USER NAME =
PLOT SCALE =
PLOT DATE = 03/28/2014

DESIGNED - CDB
CHECKED - AEC
DRAWN - AEC
CHECKED - CDB

REVISED
REVISED
REVISED
REVISED

STATE OF ILLINOIS
DEPARTMENT OF TRANSPORTATION

MAIN SPAN BOTTOM LATERAL CONNECTION PLATE REPLACEMENTS - 1
S.N. 082-6001 MLK BRIDGE OVER MISSISSIPPI RIVER

SHEET NO. 580 OF 5138 SHEETS

F.A.P. RTE.	SECTION	COUNTY	TOTAL SHEETS	SHEET NO.
799	1BR, DRS-2	ST. CLAIR	156	98

CONTRACT NO. 76B03
ILLINOIS FED. AID PROJECT

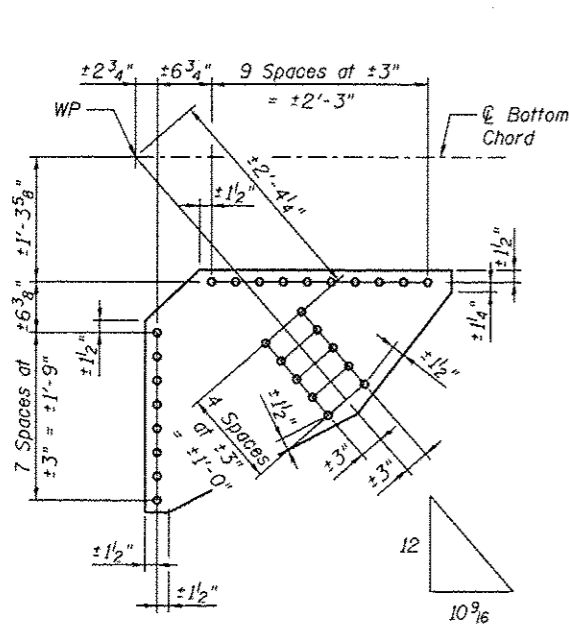

L15N-L16S AT L16S
L16'N-L15'S AT L16'N
 $\varnothing \frac{3}{8} \times 30\frac{1}{2} \times 3'-0\frac{3}{4}$

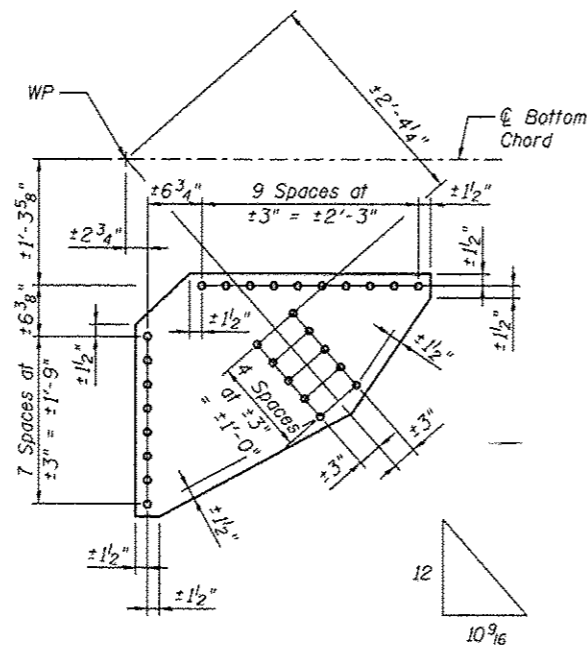

L17N-L18S AT L18S
L18'N-L17'S AT L18'N
 $\varnothing \frac{3}{8} \times 30\frac{1}{2} \times 3'-0\frac{3}{4}$

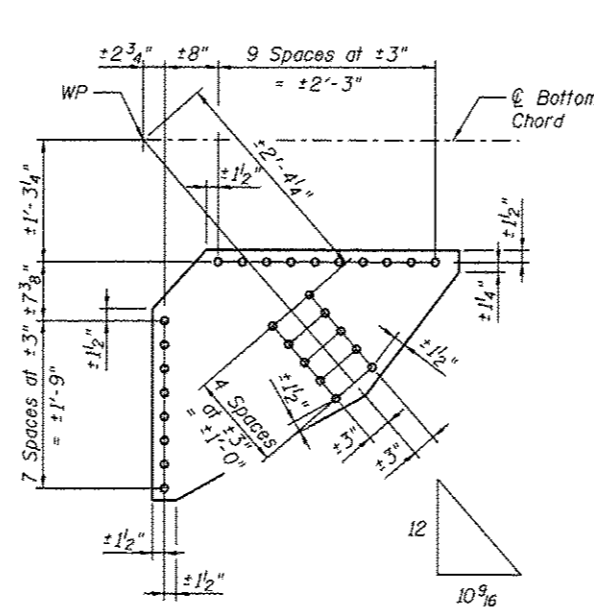

L18N-L19S AT L19S
 $\varnothing \frac{3}{8} \times 31\frac{3}{8} \times 3'-2"$

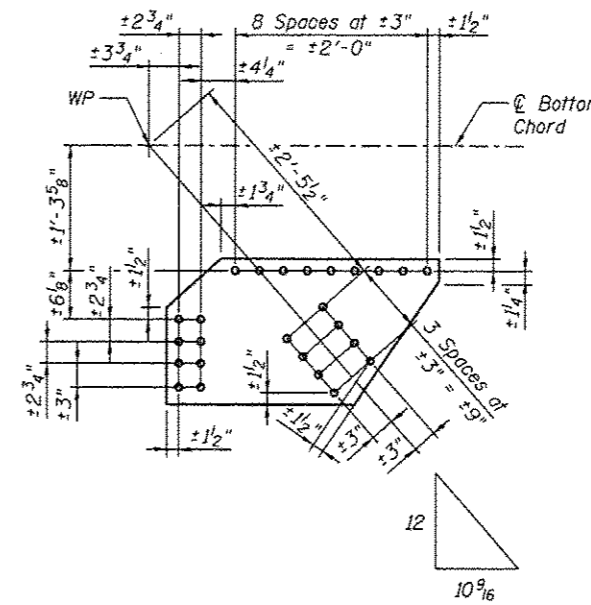

L22'N-L21'S AT L21'S
 $\varnothing \frac{5}{8} \times 18\frac{3}{4} \times 2'-10"$

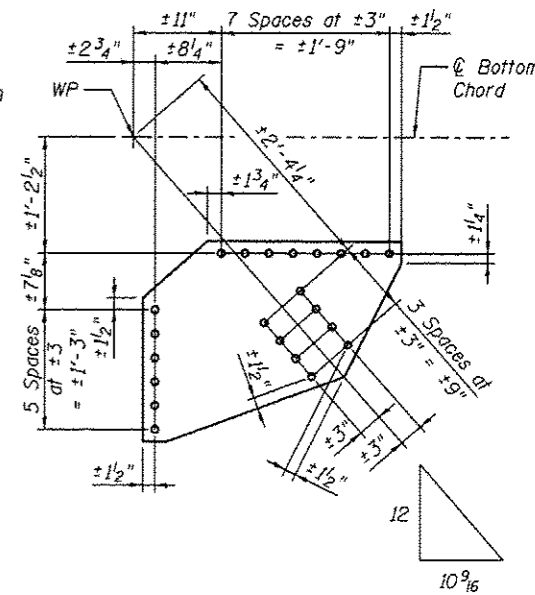

L21'S-L20'N AT L21'S
 $\varnothing \frac{3}{8} \times 25\frac{1}{2} \times 2'-8\frac{1}{4}$

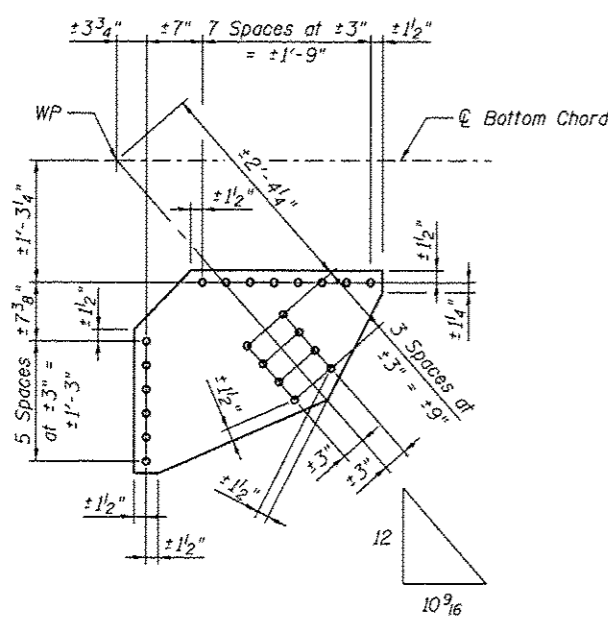

L20'N-L19'S AT L19'S
 $\varnothing \frac{3}{8} \times 25\frac{1}{2} \times 2'-7"$

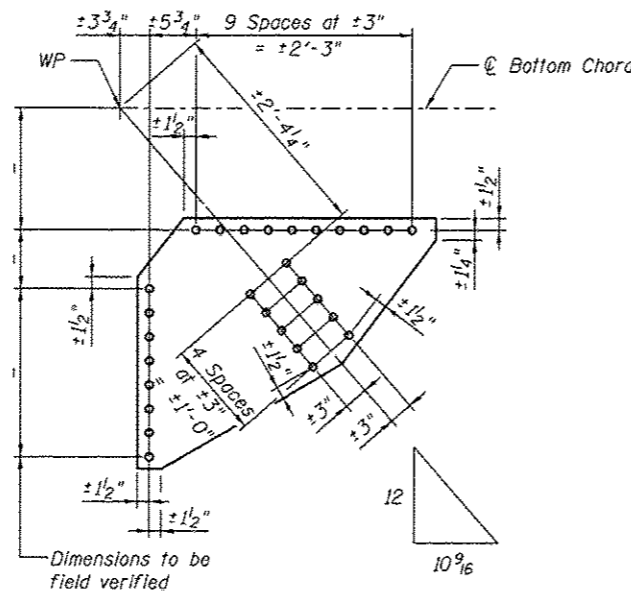

L13'S-L12'N AT L12'N
 $\varnothing \frac{3}{8} \times \dots \times 2'-11\frac{3}{4}$

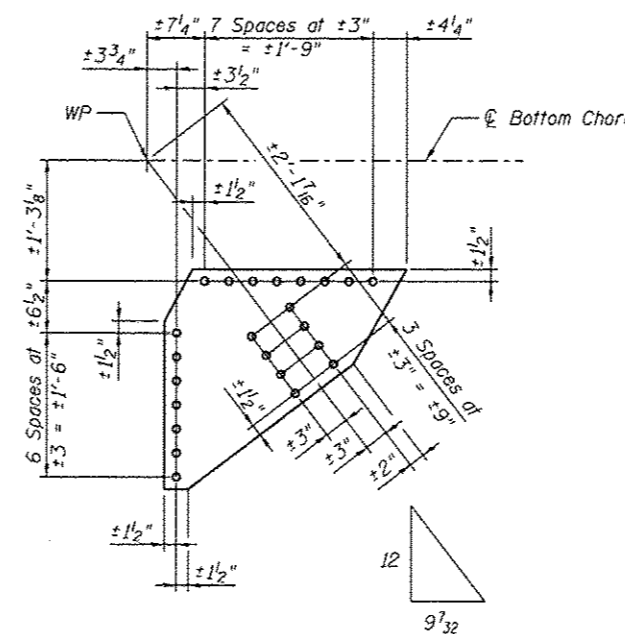

L7'N-L6'S AT L6'S
 $\varnothing \frac{3}{8} \times 27\frac{1}{2} \times 2'-6\frac{1}{4}$

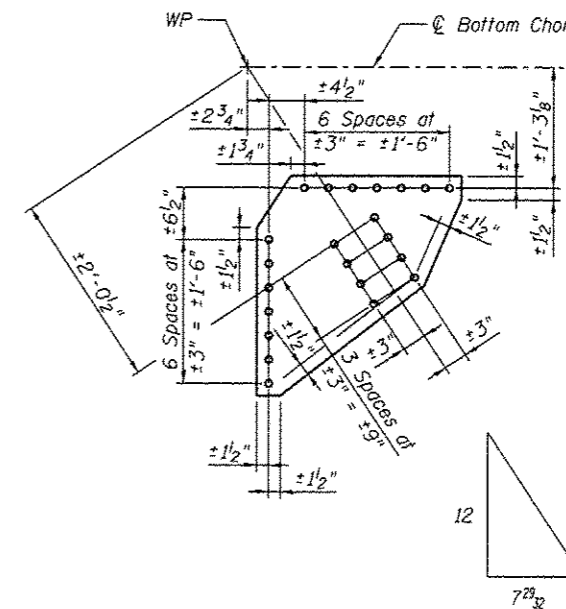

L6'N-L5'S AT L6'N
 $\varnothing \frac{3}{8} \times 27\frac{1}{2} \times 2'-1\frac{1}{2}$

BILL OF MATERIAL

Item	Unit	Total
Structural Steel Repair	Pound	1050

Note:
Field drill holes using existing holes as template.



USER NAME =	DESIGNED - CDB	REVISED
PLOT SCALE =	CHECKED - AEC	REVISED
PLOT DATE = 03/20/2014	DRAWN - AEC	REVISED
	CHECKED - CDB	REVISED

STATE OF ILLINOIS
DEPARTMENT OF TRANSPORTATION

MAIN SPAN BOTTOM LATERAL CONNECTION PLATE REPLACEMENTS - 2
S.N. 082-6001 MLK BRIDGE OVER MISSISSIPPI RIVER

SHEET NO. 581 OF 5138 SHEETS

F.A.P. RTE. 799	SECTION 1BR, DRS-2	COUNTY ST. CLAIR	TOTAL SHEETS 156	SHEET NO. 99
ILLINOIS FED. AID PROJECT			CONTRACT NO. 76B03	

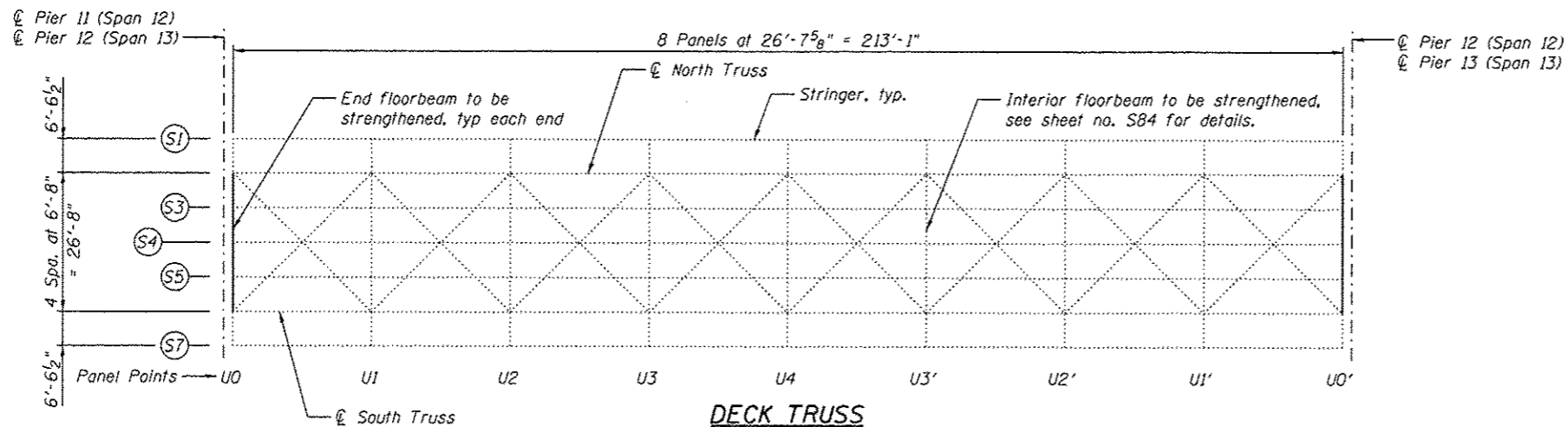
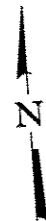

**DECK TRUSS
PARTIAL FRAMING PLAN
END FLOORBEAM STRENGTHENING**
Spans 12 and 13

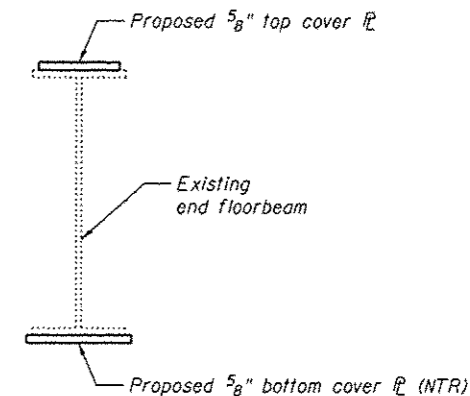

SECTION A-A
(Deck and Stringers not shown for clarity.)

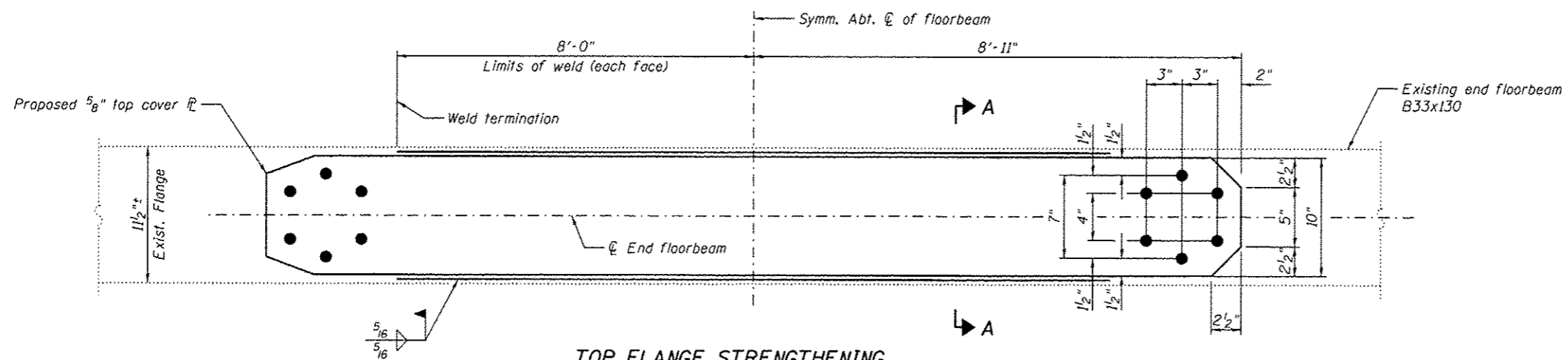

**TOP FLANGE STRENGTHENING
AT END FLOORBEAM**
(2 Locations - Pier 12, Span 12 and Pier 12, Span 13)

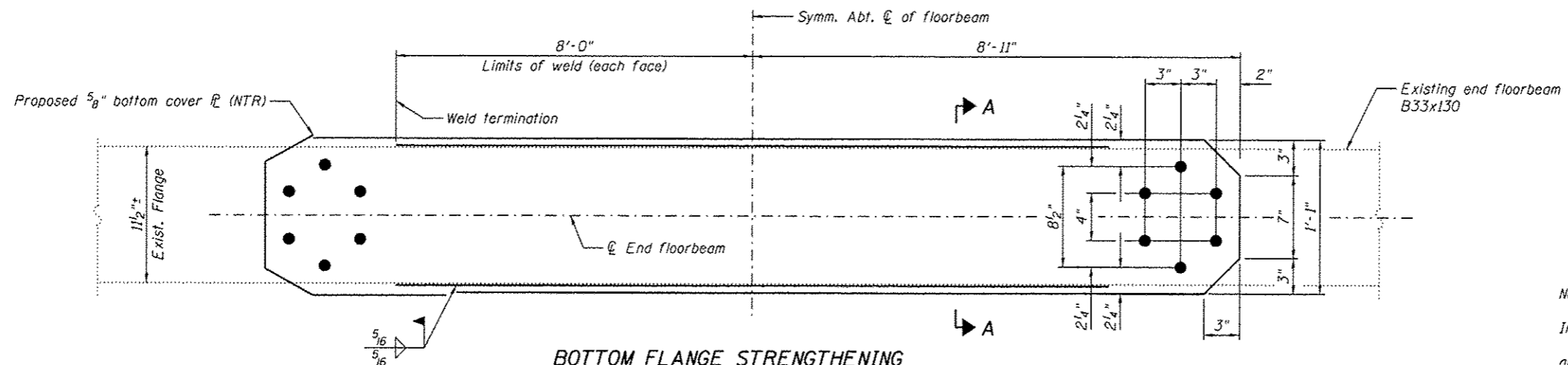

**BOTTOM FLANGE STRENGTHENING
AT END FLOORBEAM**
(4 Locations)

BILL OF MATERIAL

Item	Unit	Total
Structural Steel Repair	Pound	3900

Notes:
Load carrying components designated "NTR" shall confirm to the Impact Testing Requirement, Zone 2.
For top cover plate details for end floorbeam at Pier 11, Span 12 and Pier 13, Span 13, see sheet S83.



USER NAME *	DESIGNED - MEL	REVISED
	CHECKED - CDB	REVISED
PLOT SCALE *	DRAWN - PRC	REVISED
PLOT DATE * 05/02/2014	CHECKED - MEL	REVISED

STATE OF ILLINOIS
DEPARTMENT OF TRANSPORTATION

IL APPROACH END FLOORBEAM STRENGTHENING - 1
SPANS 12 AND 13
S.N. 082-6001 MLK BRIDGE OVER MISSISSIPPI RIVER

SHEET NO. S82 OF S138 SHEETS

F.A.P. RTE. 799	SECTION 1BR, ORS-2	COUNTY ST. CLAIR	TOTAL SHEETS 156	SHEET NO. 100
ILLINOIS FED. AID PROJECT			CONTRACT NO. 76803	