

P. A. L. NO.	SECTION	COUNTY	TOTAL SHEETS	SHEET NO.
	2001-167R	COOK	1207	324
STA. 7+250	TO STA. 7+550			
FED. ROAD DIST. NO.	ILLINOIS	FED. AID PROJECT		
CONTRACT NO. 62114				

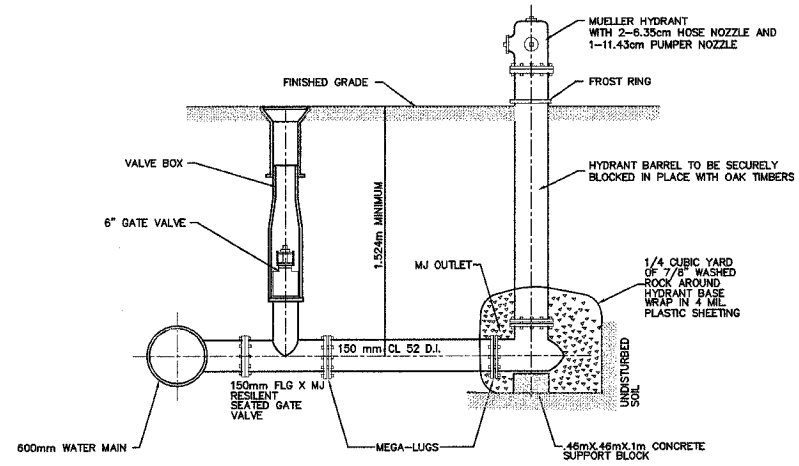

**FIRE HYDRANT INSTALLATION**

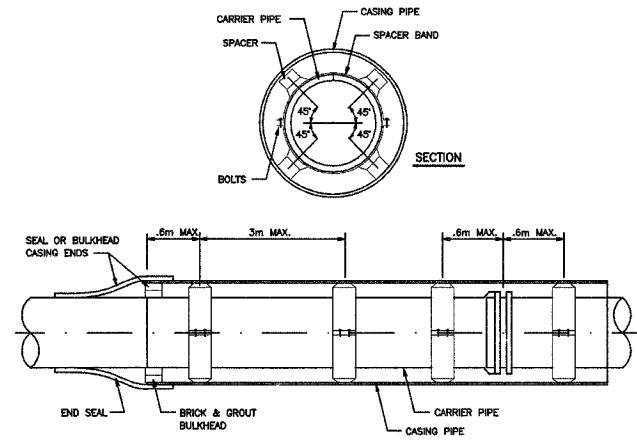

**DUCTILE IRON PIPE CASING SPACER INSTALLATION**

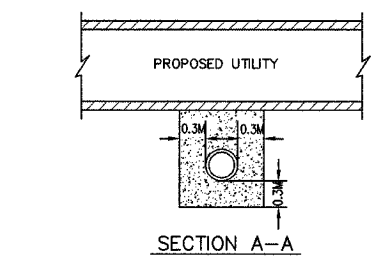
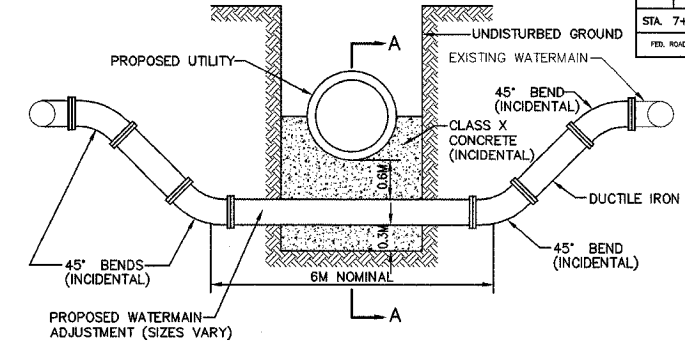

**DETAIL OF WATERMAIN ADJUSTMENT**

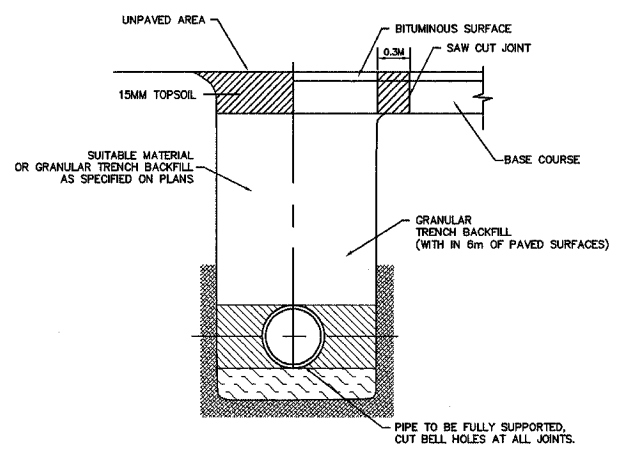

**TYPE 3 TRENCH BACKFILL DETAIL FOR DUCTILE IRON WATERMAIN**

NOTE: PIPE BEDDED IN 4" MINIMUM LOOSE SOIL. BACKFILL LIGHTLY CONSOLIDATED TO TOP OF PIPE. MAX. DEPTH OF COVER 14'. ANS/AWWA C150/A21.50 AND ANS/AWWA C151/A21.51 STANDARD LAYING CONDITIONS

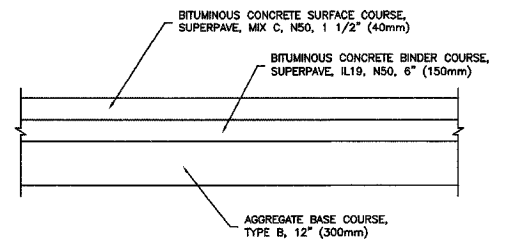

**PAVEMENT REPLACEMENT TYPICAL CROSS-SECTION**

PREPARED BY OR UNDER THE DIRECT SUPERVISION OF:  
*Jennifer A. Prinz*  
 9-7-05



REVISIONS	
NAME	DATE

ILLINOIS DEPARTMENT OF TRANSPORTATION

**CONSTRUCTION DETAILS**

SCALE: VERT. N/A  
 HORIZ. N/A  
 DATE 2/3/05

DRAWN BY JM  
 CHECKED BY JSP