

F.A.I. RTE.	SECTION	COUNTY	TOTAL SHEETS	SHEET NO.
80/94	2626.2-R-2	COOK/LAKE	1207	420
STA.	TO STA.			
FED. ROAD DIST. NO.	ILLINOIS FED. AID PROJECT			
CONTRACT NO. 62114	INDOT DES. NO. 0100987			

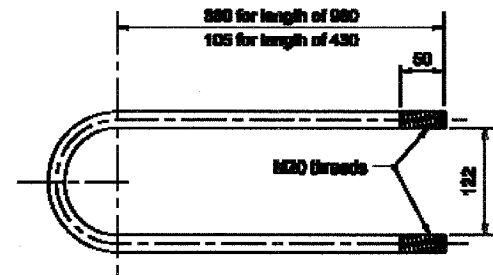

**3/8 IN. STAINLESS STEEL U-BOLT DETAIL**

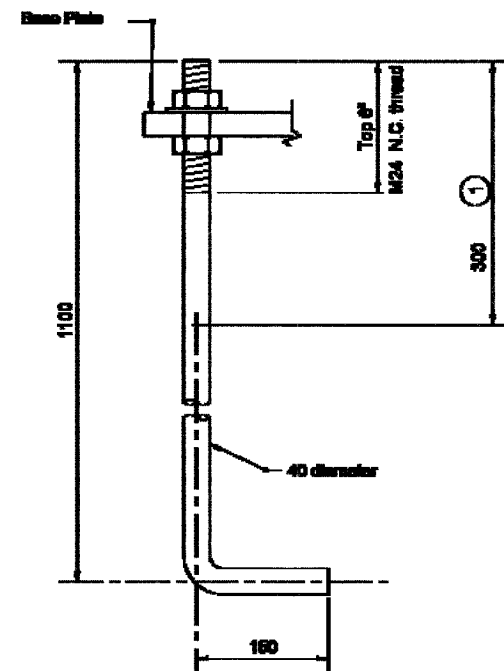

**ANCHOR BOLT DETAIL**

**NOTES:**  
① After threading, coat or mechanically galvanize as required.

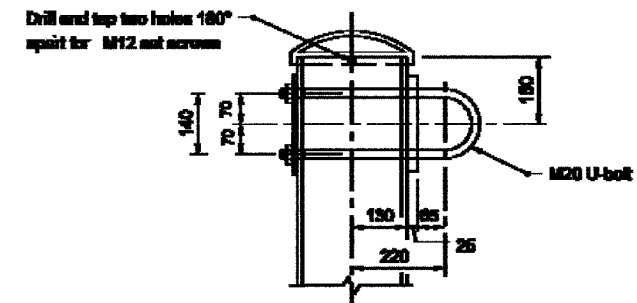

**UPPER CHORD CONNECTION DETAIL**

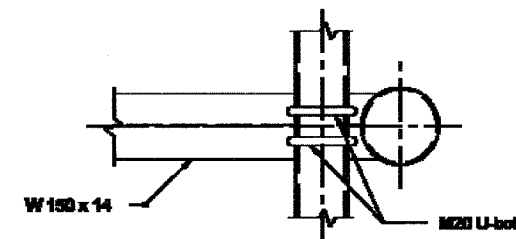

**LOWER CHORD CONNECTION DETAIL**

*All Dimensions are in mm unless otherwise specified*

**INDIANA DEPARTMENT OF TRANSPORTATION**

**ALUMINUM STRUCTURE BOLT DETAILS**

**MARCH 2004**

**STANDARD DRAWING NO. 802-SNOH-08**

	<i>Richard L. VanCleave</i> 3-0-04 REGISTERED PROFESSIONAL ENGINEER
	<i>Richard L. VanCleave</i> 3-0-04 Special Inspector