

**ELEVATION AT ABUT.**

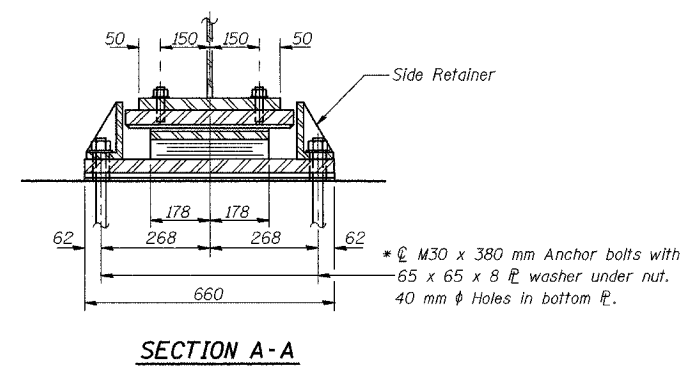

**SECTION A-A**

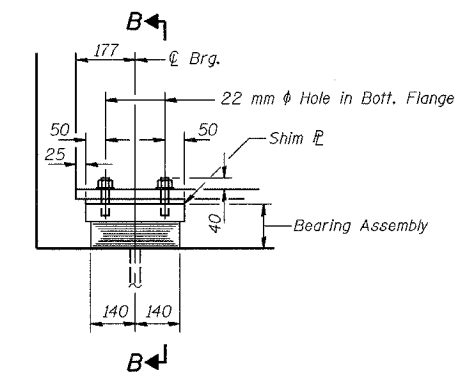

**ELEVATION AT ABUT.**

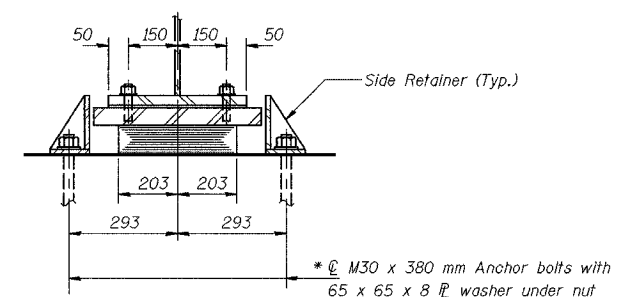

**SECTION B-B**

**TYPE II ELASTOMERIC EXP. BRG. AT WEST ABUTMENT**

**TYPE I ELASTOMERIC WEST EXP. BRG. AT PIER 3 GIRDERS 1-14**

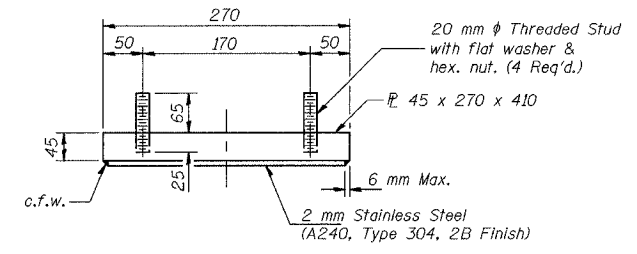

**TOP BEARING ASSEMBLY**

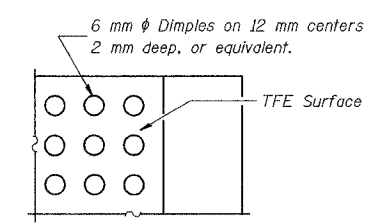

**PLAN-TFE SURFACE**

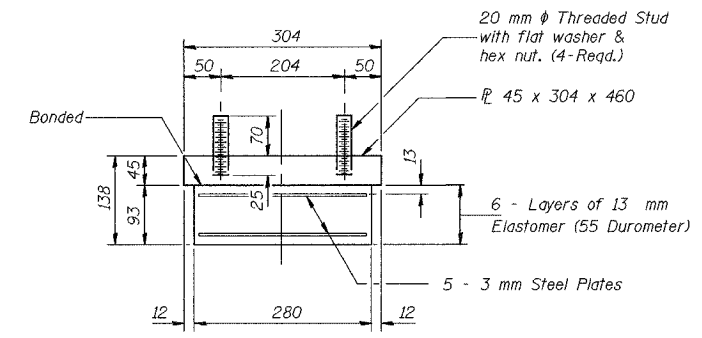

**BEARING ASSEMBLY**

Notes: See Sheet S-47 for Anchor Bolt Installation. All dimensions are in millimeters (mm) except as noted.

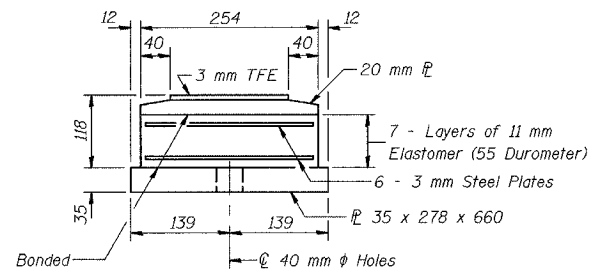

**BOTTOM BEARING ASSEMBLY**

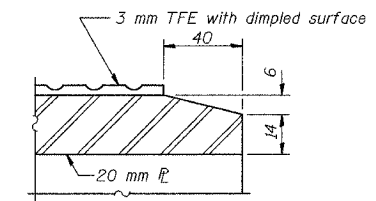

**SECTION THRU TFE**

Note: Shim plates shall not be placed under Bearing Assembly.

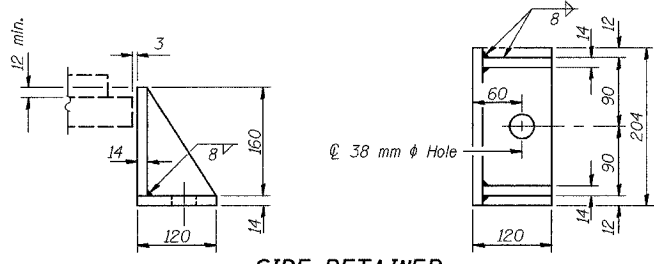

**SIDE RETAINER**

Note: The 3 mm TFE sheet shall be bonded directly to the top steel plate with a two-component, medium viscosity epoxy resin, conforming to the requirements of the Federal Specification MMM-A-134, Type I. The bond agent shall be applied on the full area of the contact surfaces.

Bonding of 3 mm TFE sheet during vulcanizing process will be permitted provided the process and method of adjusting assembly height is approved by the Engineer.

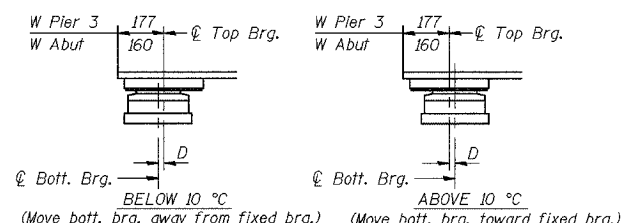

**SETTING ANCHOR BOLTS AT EXP. BRG.**

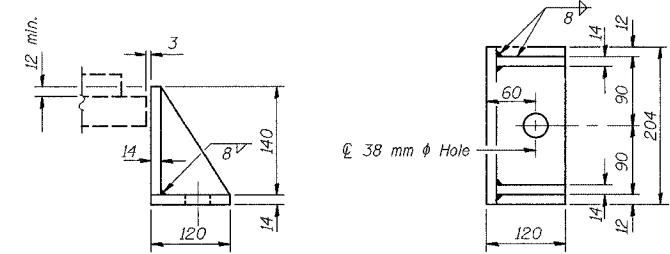

**SIDE RETAINER**

DESIGNED	BHS
CHECKED	KFA
DRAWN	MJB
CHECKED	GSP

**BILL OF MATERIAL**

Item	Unit	Total
* Furnishing Elastomeric Bearing Assembly, Type I	Each	14
* Furnishing Elastomeric Bearing Assembly, Type II	Each	28

ILLINOIS DEPARTMENT OF TRANSPORTATION  
 F.A.I. ROUTE 80/94 (BORMAN EXPRESSWAY)  
 OVER LITTLE CALUMET RIVER & N.I.C.T.D. R.O.W.  
 BEARING DETAILS (2 OF 5)  
 SECTION 2626.2-R-1  
 LAKE COUNTY, INDIANA  
 STATION 8+470.000  
 STRUCTURE NO. I-80-1-8460 (EB & WB)  
 DATE 07/05 (016-1003 & 016-1004)



**\* FURNISHING BEARINGS NOT INCLUDED IN THIS CONTRACT**