

ROUTE NO.	SECTION	COUNTY	SHEET	SHEET NO. S-3
P.A.L. 88/74	2626.2-R-1	LAKE COUNTY, INDIANA	1207	1065
CONTRACT NO. 62114		INDOT DES. NO. 0100987		

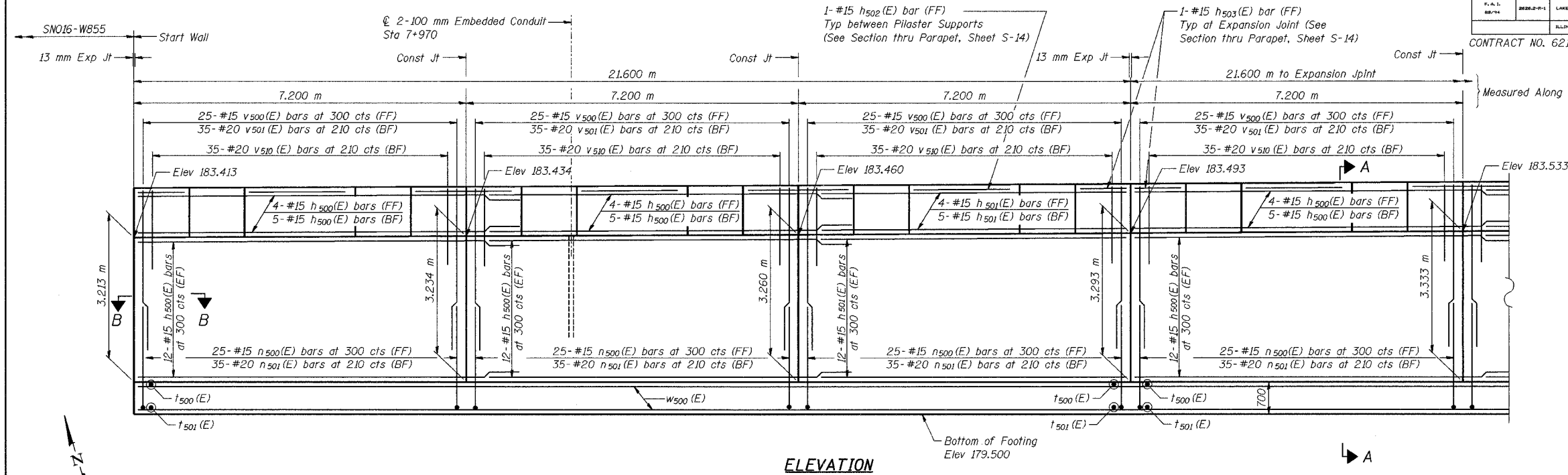

**ELEVATION**

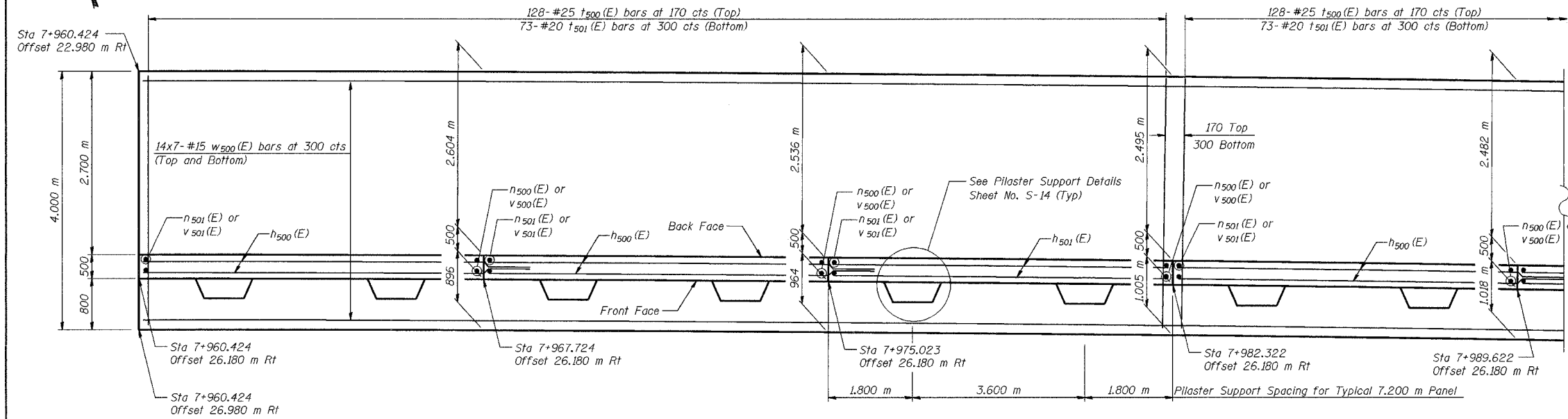

**FOOTING PLAN**

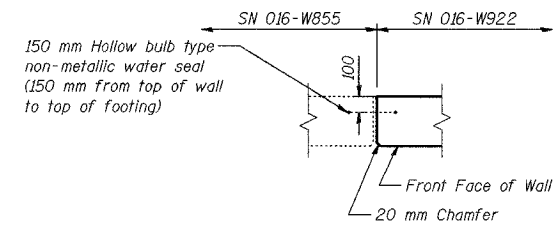

**SECTION B-B**

DESIGNED	MJW
CHECKED	KFA
DRAWN	MJB
CHECKED	GSP

**MINIMUM BAR LAPS**  
 #15 bars = 640  
 #20 bars = 790

**LEGEND**  
 BF = Back Face  
 FF = Front Face  
 EF = Each Face

**NOTES:**  
 See Sheet S-14 or Section A-A, Expansion Joint Detail, and Bill of Material.  
 See Sheet S-15 for Rustication details.  
 Stations are referenced to  $\pm$  1-80/94.  
 Reinforcement bars designated (E) shall be epoxy coated.  
 All dimensions are in millimeters (mm) except as noted.  
 Bars indicated thus 20x3-#15 etc. indicates 20 lines of bars with 3 lengths per line.  
 See Electrical Drawings for Conduit Details

ILLINOIS DEPARTMENT OF TRANSPORTATION  
 I-80/94/US 6  
 KINGERY-BORMAN EXPRESSWAY  
 BURNHAM ROAD TO US 41  
**PLAN AND ELEVATION (1 OF 11)**  
 SECTION 2626.2-R-1  
 LAKE COUNTY, INDIANA  
 STATION 7+960.424 TO STATION 8+199.354  
 STRUCTURE NO. 016-W922  
 DATE 07/05  
**AMERICAN**  
 CONSULTING ENGINEERS

FOR INFORMATION ONLY