

SECTION A-A

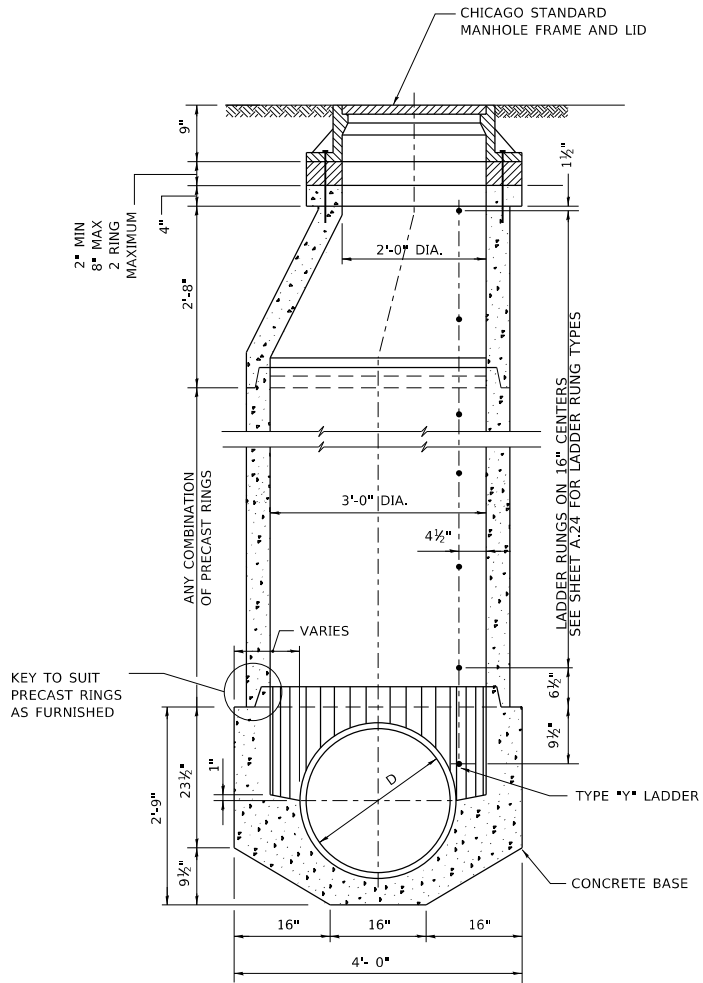

SECTION B-B

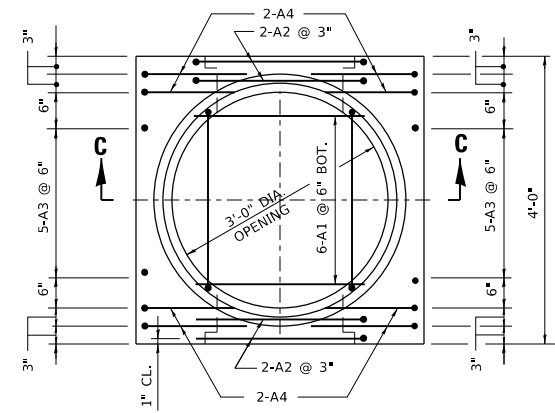

**PLAN
PRECAST BASE**

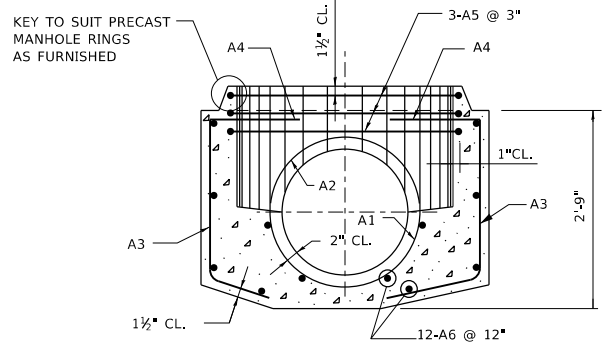

SECTION C-C

NOTE:
6" MINIMUM GRANULAR EMBEDMENT
UNDER ALL PRECAST MANHOLE BASES

| SCHEDULE OF REINFORCEMENT | | | | | | | | | | | | | | | | | | | | | |
|---------------------------------------|-------------------|----------|------|---------|------------|-------------------|-------|--------------------|---|-----------|-----|-----|---|---|---|--------|---|---------|-----------|-----------|-----------|
| STRUCTURE | REINFORCEMENT BAR | | | | | | | BENDING DIMENSIONS | | | | | | | | | | | | | |
| | MARK | SIZE NO. | TYPE | LENGTH | NO. REQD. | WEIGHT - LBS EACH | TOTAL | A | B | C | D | E | F | G | H | J | K | O | R | | |
| BASES FOR TYPE "A" MANHOLES (PRECAST) | 21" DIA. | 21A1 | 6 | 9 | 3'-1" | 6 | 4.63 | 28 | | 3'-1" | | | | | | | | 11 1/2" | 2'-1" | 12 3/4" | |
| | | 21A2 | 6 | T3 | 8'-8" | 4 | 13.02 | 52 | | | | | | | | | | | 2'-0" | 2'-1 1/2" | |
| | | 21A3 | 5 | 12 | 3'-3" | 10 | 3.39 | 34 | | | 22" | 17" | | | | | | | 14 1/2" | 8 3/4" | |
| | | 21A4 | 5 | 12 | 4'-6" | 8 | 4.69 | 38 | | 15" | 22" | 17" | | | | | | | 14 1/2" | 8 3/4" | |
| | | 21A5 | 5 | T3 | 11'-11" | 3 | 12.43 | 37 | | | | | | | | | | | 20" | 3'-3 1/4" | |
| | | 21A6 | 4 | STR | 3'-8" | 12 | 2.45 | 30 | | | | | | | | | | | | | |
| | | | | | | | | 219 | | | | | | | | | | | | | |
| | 18" DIA. | 18A1 | 6 | 9 | 2'-8 1/2" | 6 | 4.07 | 24 | | 2'-8 1/2" | | | | | | 9 3/4" | | | 22" | 11 1/4" | |
| | | 18A2 | 6 | T3 | 7'-10 1/2" | 4 | 11.83 | 47 | | | | | | | | | | | 2'-0" | 22 1/2" | |
| | | 18A3 | 5 | 12 | 3'-3" | 10 | 3.39 | 34 | | | 22" | 17" | | | | | | | 14 1/2" | 8 3/4" | |
| | | 18A4 | 5 | 12 | 4'-6" | 8 | 4.69 | 38 | | 15" | 22" | 17" | | | | | | | 14 1/2" | 8 3/4" | |
| | | 18A5 | 5 | T3 | 11'-11" | 3 | 12.43 | 37 | | | | | | | | | | | 2'-0" | 3'-3 1/4" | |
| | | 18A6 | 4 | STR | 3'-8" | 12 | 2.45 | 30 | | | | | | | | | | | | | |
| | | | | | | | | 202 | | | | | | | | | | | | | |
| | 15" DIA. | 15A1 | 6 | 9 | 2'-3 1/2" | 6 | 3.44 | 21 | | 23 1/2" | | | | | | | | | 8 3/4" | 19" | 9 3/4" |
| | | 15A2 | 6 | T3 | 7'-1" | 4 | 10.64 | 42 | | | | | | | | | | | 2'-0" | 19 1/2" | |
| | | 15A3 | 5 | 12 | 3'-3" | 10 | 3.39 | 34 | | | 22" | 17" | | | | | | | 8 3/4" | | |
| | | 15A4 | 5 | 12 | 4'-6" | 8 | 4.69 | 38 | | 15" | 22" | 17" | | | | | | | 14 1/2" | 8 3/4" | |
| | | 15A5 | 5 | T3 | 11'-11" | 3 | 12.43 | 37 | | | | | | | | | | | 14 1/2" | 20" | 3'-3 1/4" |
| | | 15A6 | 4 | STR | 3'-8" | 12 | 2.45 | 30 | | | | | | | | | | | | | |
| | | | | | | | | 202 | | | | | | | | | | | | | |
| | 12" DIA. | 12A1 | 6 | 9 | 1'-11" | 6 | 2.88 | 17 | | 23" | | | | | | | | | 6 3/4" | 16" | 8 3/4" |
| | | 12A2 | 6 | T3 | 6'-1" | 4 | 9.14 | 37 | | | | | | | | | | | 2'-0" | 16 1/2" | |
| | | 12A3 | 5 | 12 | 3'-3" | 10 | 3.39 | 34 | | | 22" | 17" | | | | | | | 14 1/2" | 8 3/4" | |
| 12A4 | | 5 | 12 | 4'-6" | 8 | 4.69 | 38 | | | 22" | 17" | | | | | | | 14 1/2" | 8 3/4" | | |
| 12A5 | | 5 | T3 | 11'-11" | 3 | 12.43 | 37 | | | | | | | | | | | 20" | 3'-3 1/4" | | |
| 12A6 | | 4 | STR | 3'-8" | 12 | 2.45 | 30 | | | | | | | | | | | | | | |
| | | | | | | | 193 | | | | | | | | | | | | | | |

MODEL: Default
 FILE: h:\projects\paw\benefit\com\paw\DOT\Documents\DOT_offices\Drawdet_1\Projects\Draw\2323\CAD\Draw\CAD\Precast\B09.dgn

| | | |
|-------------------------------|-----------------|-----------------------------|
| USER NAME = Lawrence,DeManche | DESIGNED - | REVISED - K. SMITH 09-22-90 |
| PLOT SCALE = 100,0000 ' / in. | DRAWN - | REVISED - K. SMITH 11-18-22 |
| PLOT DATE = 11/18/2022 | CHECKED - | REVISED - |
| | DATE - 06-18-82 | REVISED - |

**STATE OF ILLINOIS
DEPARTMENT OF TRANSPORTATION**

| | | | |
|---|---------------------|--------------|--|
| CITY OF CHICAGO DRAINAGE DETAILS | | | |
| TYPE "A" PRECAST MANHOLE FOR SEWERS 21" DIA. AND SMALLER | | | |
| SCALE: NONE | SHEET 1 OF 1 SHEETS | STA. TO STA. | |

| | | | | |
|---------------------------|---------|--------------|--------------|-----------|
| F.A. RTE. | SECTION | COUNTY | TOTAL SHEETS | SHEET NO. |
| | | | | |
| BD600-12 (BD-09) | | CONTRACT NO. | | |
| ILLINOIS FED. AID PROJECT | | | | |