

F.A.U. RTE.	SECTION	COUNTY	TOTAL SHEETS	SHEET NO.
3578	15V B-1-R-1	COOK	243	135
STA.		TO STA.		
FED. ROAD DIST. NO.		ILLINOIS FED. AID PROJECT		
CONTRACT NO. 62388				

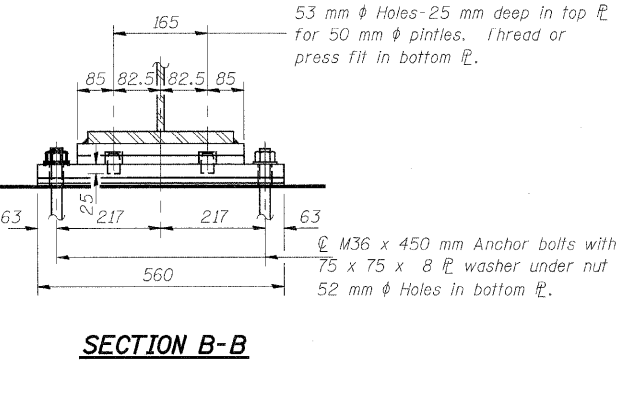

TYPE II ELASTOMERIC EXP. BRG.

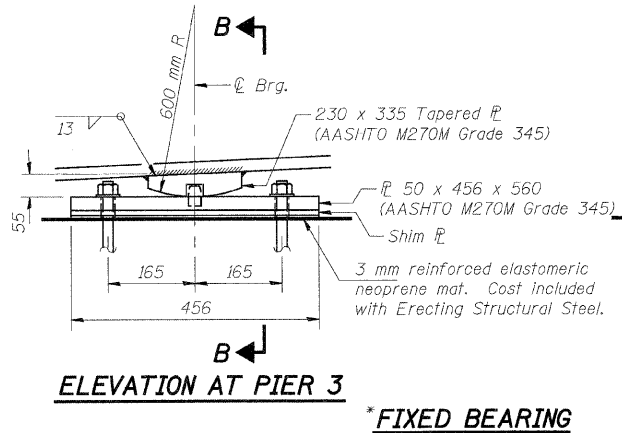
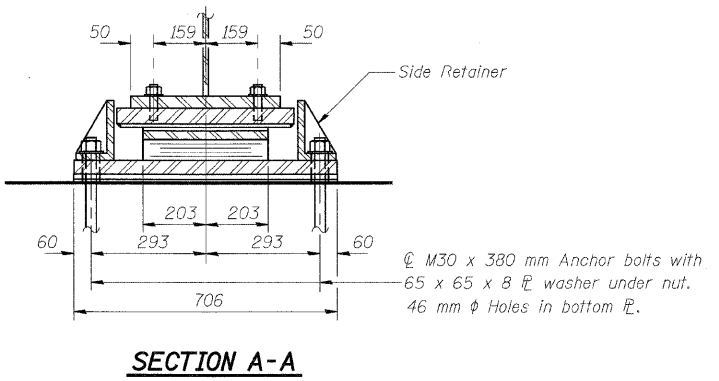
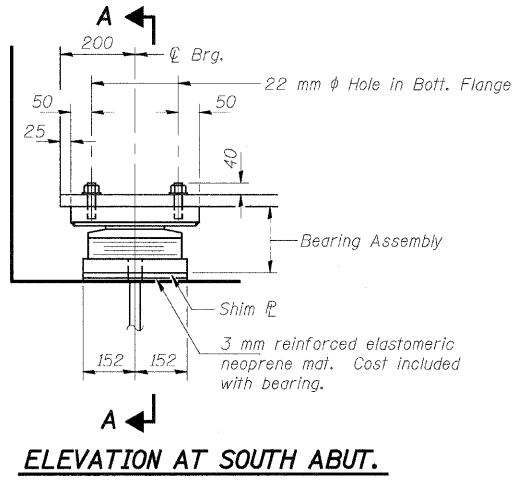
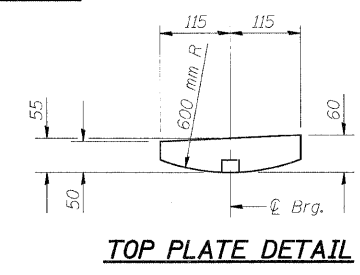
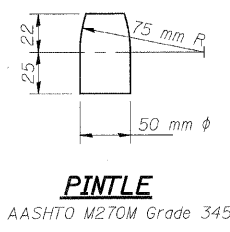
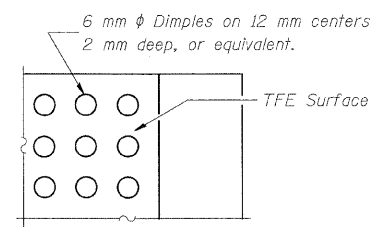
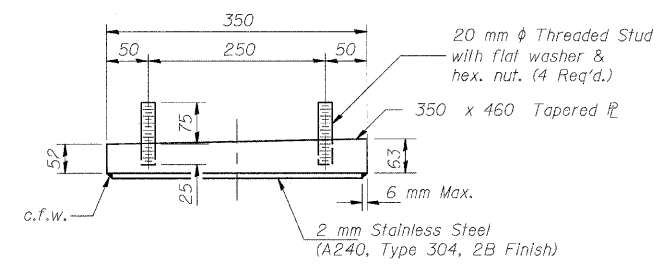

* Fixed bearings provided in a separate Fabrication Contract. Cost of erecting fixed bearings included in cost of Erecting Structural Steel.

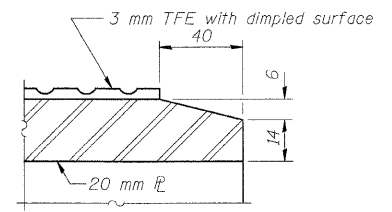
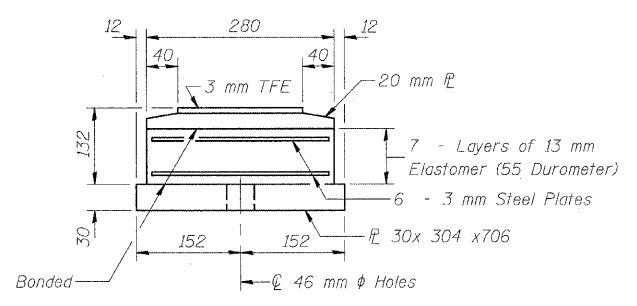

Note: The 3 mm TFE sheet shall be bonded directly to the top steel plate with a two-component, medium viscosity epoxy resin, conforming to the requirements of the Federal Specification MMM-A-134, Type I. The bond agent shall be applied on the full area of the contact surfaces.

Bonding of 3 mm TFE sheet during vulcanizing process will be permitted provided the process and method of adjusting assembly height is approved by the Engineer.

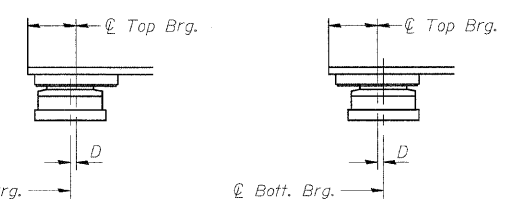
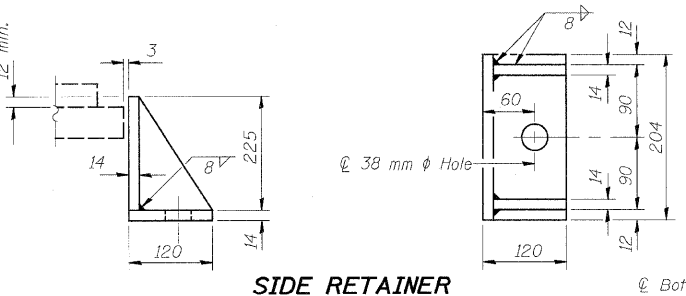

For S. Abutment
Equivalent rolled angle with stiffeners will be allowed in lieu of welded plates.

(Move bott. brg. away from fixed brg.) (Move bott. brg. toward fixed brg.)

SETTING ANCHOR BOLTS AT EXP. BRG.
D = 1 mm per each 10 m of expansion for every 8 C temp. change from the normal temp. of 10 C.

NOTES

- Anchor bolts at fixed bearings may be built into the masonry.
- See sheets #SA46 & #SA53 for Anchor Bolt installation.
- All dimensions are in millimeters (mm) except as noted.
- Side retainers and other steel members required for the bearing assembly shall be included in the cost of Elastomeric Bearing Assembly, Type II.

BILL OF MATERIAL

Item	Unit	Total
Elastomeric Bearing Assembly Type II	Each	8
Anchor Bolts, M30	Each	16
Anchor Bolts, M36	Each	32

REVISIONS	
NAME	DATE

ILLINOIS DEPARTMENT OF TRANSPORTATION
BEARING DETAILS - UNIT I
SOUTH ABUTMENT & PIER 3
SOUTHWEST HIGHWAY OVER
B&O RAILROAD AND STONY CREEK
FAU 3578 SECTION 15V B-1-R-1
STRUCTURE NUMBER 016-2771
COOK COUNTY STATION 4+716.497
 SCALE: NONE DRAWN BY: E. Mroozek
 DATE: 6/17/09 CHECKED BY: G. Hatlestad

O:\VDDT\9556_A0\Drawings\STRUCT\40_brgs_S_Abut_Pier3.dgn
 H:\open\rdwy_lisle\6/26/2009 8:22:13 AM
PATRICK ENGINEERING INC.
 LISLE, ILLINOIS