

**COMBINATION CURB AND GUTTER REMOVAL, COMBINATION CONCRETE CURB AND GUTTER REMOVAL AND REPLACEMENT (SPECIAL), COMBINATION CONCRETE CURB AND GUTTER TYPE B-6.12 (SPECIAL) DETAIL**  
(NOT TO SCALE)

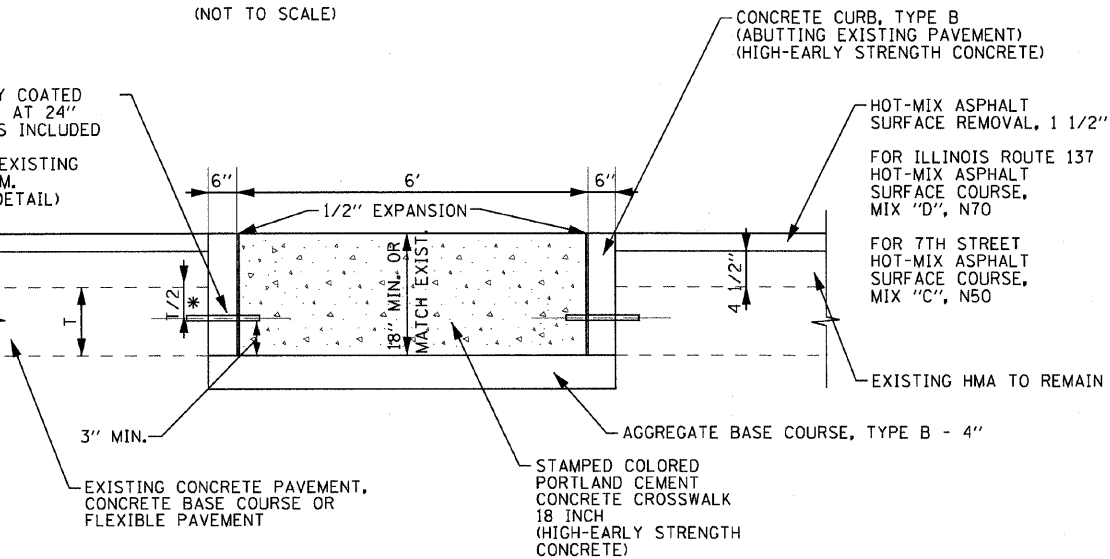

NOTES:  
1. WHEN ADJACENT TO FLEXIBLE PAVEMENT USE 18" LONG EPOXY COATED TIE BARS.

**STAMPED COLORED PORTLAND CEMENT CONCRETE CROSSWALK 18 INCH DETAIL**  
(NOT TO SCALE)

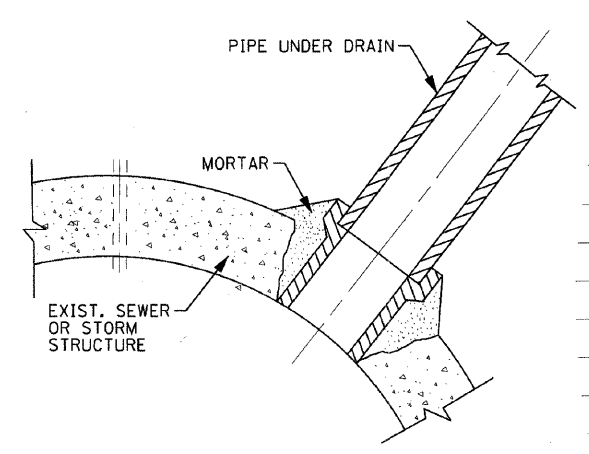

**STORM SEWER CONNECTION, SPECIAL**  
(NOT TO SCALE)

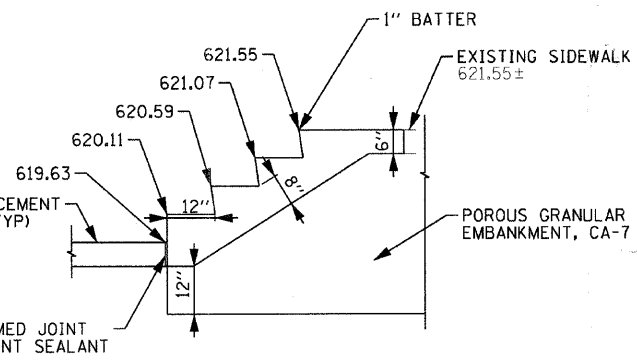

**CONCRETE STAIRS DETAIL**  
NOT TO SCALE

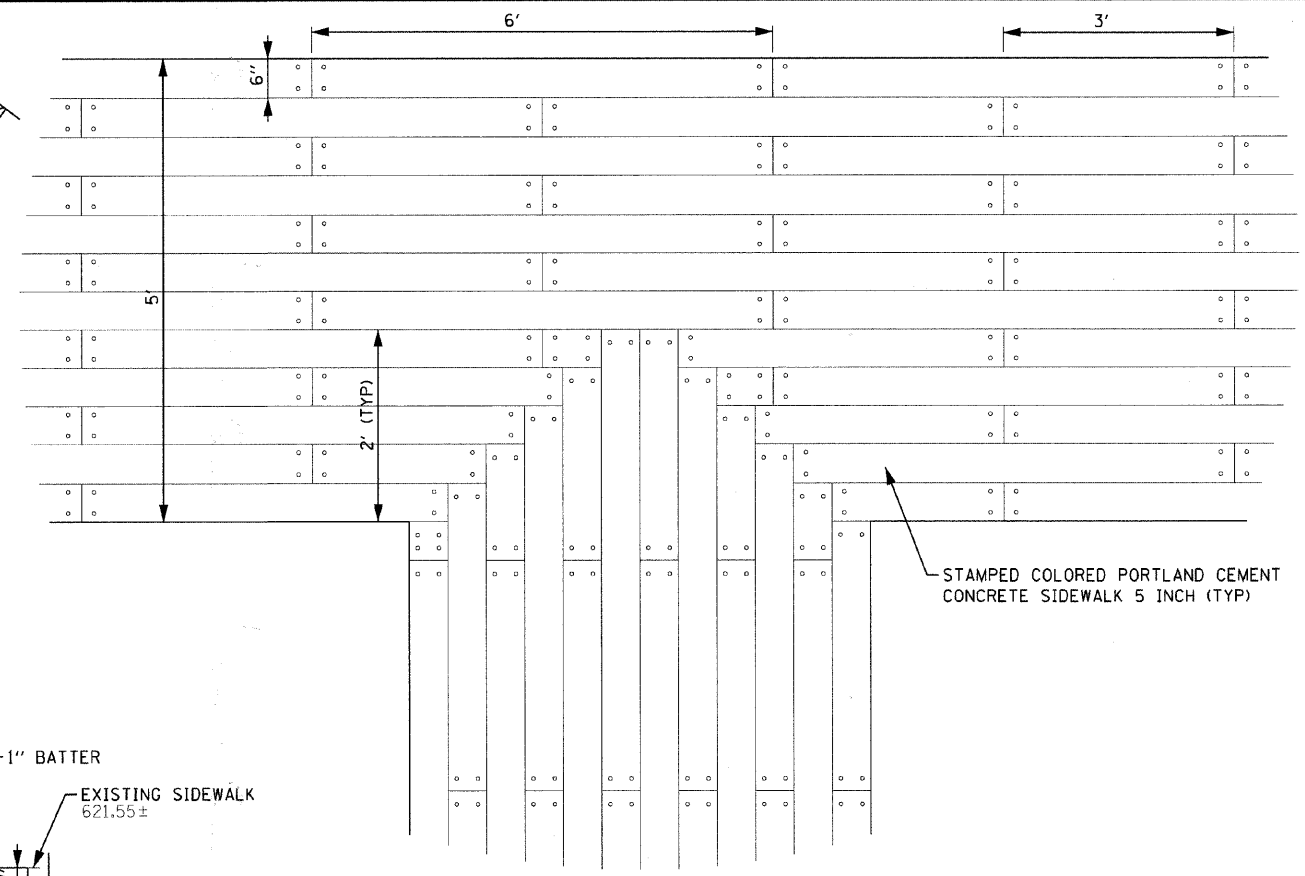

**STAMPED COLORED PORTLAND CEMENT CONCRETE SIDEWALK AT STREET LIGHT DETAIL**  
(NOT TO SCALE)

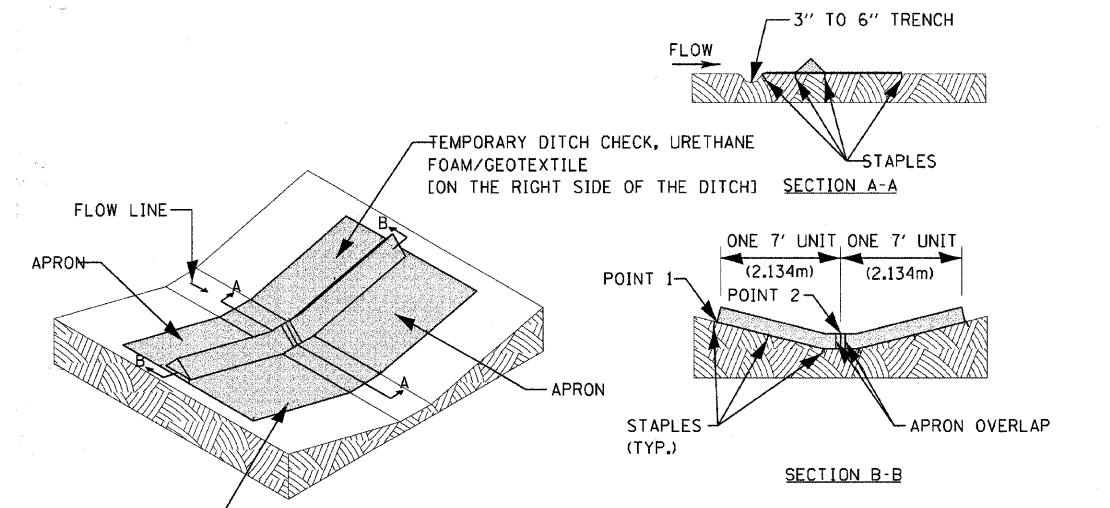

NOTES:  
1. THE INSTALLATION SHOWN ABOVE WILL BE MEASURED FOR PAYMENT IN FEET PERPENDICULAR TO THE FLOW LINE.

**TEMPORARY DITCH CHECK**  
NO SCALE

COPYRIGHT © 2009 BY BAXTER & WOODMAN, INC.  
 STATE OF ILLINOIS - PROFESSIONAL DESIGN FIRM  
 LICENSE NO. 064-00021 - EXPIRES 4/30/2011  
 06/28/2009

DESIGNED - MWP	REVISED - IDOT REVIEW 2/19/09
DRAWN - CJC	REVISED - IDOT REVIEW 4/22/09
CHECKED - MDW	REVISED - IDOT REVIEW 11/17/09
DATE - 8-1-08	REVISED -

**VILLAGE OF WINTHROP HARBOR, ILLINOIS**  
**ILLINOIS ROUTE 137 (SHERIDAN ROAD) AND 7th STREET**  
**STREETScape IMPROVEMENTS**

SCALE: NONE		STA. TO STA.	
<b>DETAILS</b>			

F.A.P. RTE.	SECTION	COUNTY	TOTAL SHEETS	SHEET NO.
06-00036-00-LS	LAKE	NO	49	
FED. ROAD DIST. NO. 1			CONTRACT NO. 63167	
JOB NO. C-91-197-10			ILLINOIS FED. AID PROJECT ARA-00DI(810)	