

F.A.U. RTE.	SECTION	COUNTY	TOTAL SHEETS	SHEET NO.
1638*	**	WILL	38	5
STA.		TO STA.		
FED. ROAD DIST. NO. -		ILLINOIS FED. AID PROJECT		
CONTRACT NO. 63316		* EXCHANGE STREET ** 09-00044-01-TL		

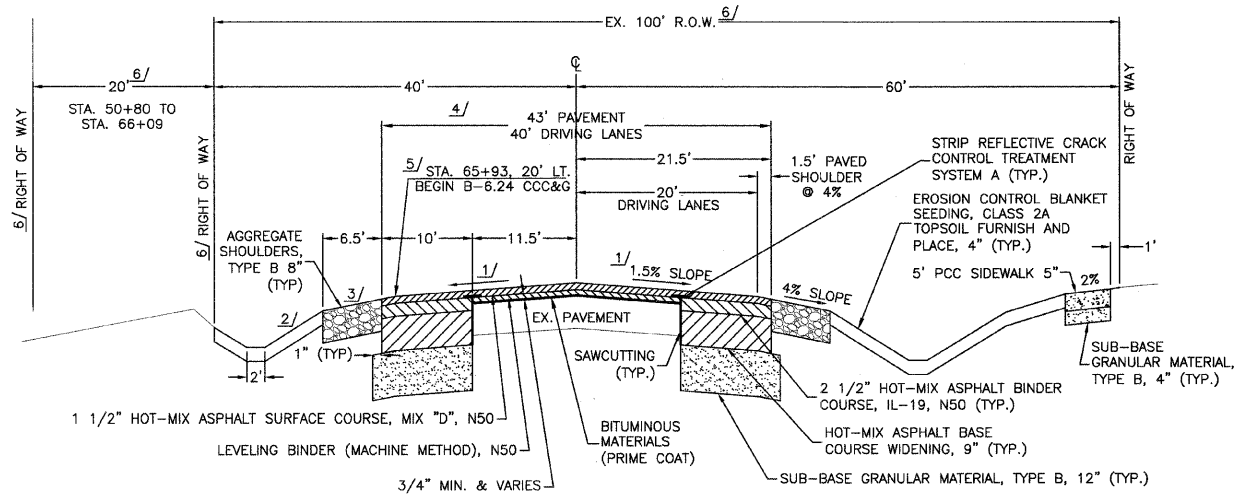

- 1/ STA. 62+25 TO STA. 65+25 AND STA. 70+25 TO STA. 73+25: PAVEMENT CROSS SLOPES VARY IN SUPERELEVATION AREA (SEE PLANS)
- 2/ STA. 50+80 TO STA. 58+50: 3:1 MIN. DITCH SLOPE
- 3/ STA. 50+80 TO STA. 54+00: SHOULDER VARIES 0' TO 6.5'
- 4/ STA. 50+80 TO STA. 54+00: PAVEMENT VARIES 40' TO 43' DRIVING LANE VARIES 24' TO 40'
- STA. 69+25 TO STA. 70+00: PAVEMENT VARIES 43' TO 36' DRIVING LANE VARIES 40' TO 36'
- 5/ STA. 65+93, LT TO STA. 70+00, LT: B-6.24 CURB & GUTTER, SEE SECTION FOR STA. 70+00 TO STA. 73+00, LOCATION VARIES 20' LT TO 18' LT
- 6/ STA. 50+80 TO STA. 66+09: 120'
- STA. 66+09 TO STA. 70+00: 100'

**PROPOSED TYPICAL PAVEMENT SECTION**  
EXCHANGE STREET  
STA. 50+80 TO STA. 70+00  
N.T.S.

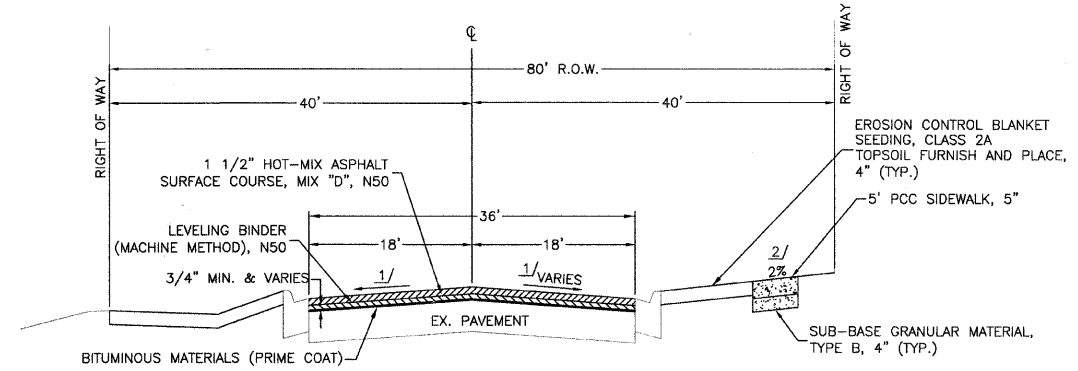

- 1/ STA. 71+41 TO STA. 73+25: PAVEMENT CROSS SLOPES VARY IN SUPERELEVATION AREA (SEE PLANS)
- 2/ STA. 71+41 TO STA. 72+40: PROP. SIDEWALK  
STA. 72+40 TO STA. 77+25: EX. SIDEWALK TO REMAIN

**PROPOSED TYPICAL PAVEMENT SECTION**  
EXCHANGE STREET  
STA. 71+41 TO STA. 77+25  
N.T.S.

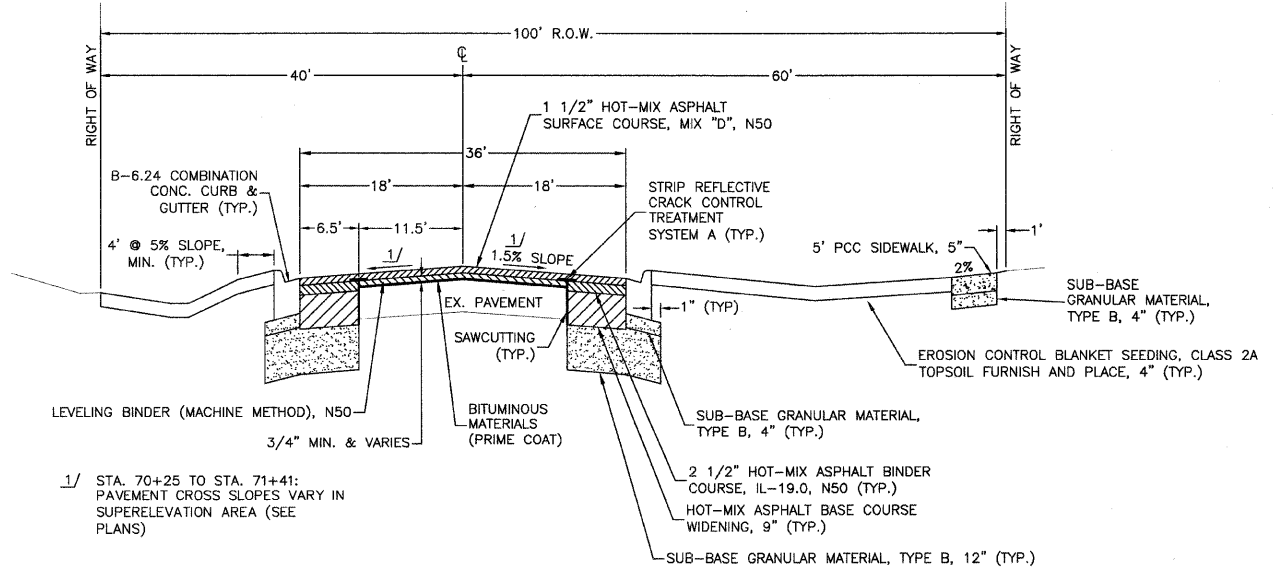

- 1/ STA. 70+25 TO STA. 71+41: PAVEMENT CROSS SLOPES VARY IN SUPERELEVATION AREA (SEE PLANS)

**PROPOSED TYPICAL PAVEMENT SECTION**  
EXCHANGE STREET  
STA. 70+00 TO STA. 71+41  
N.T.S.

REVISIONS		
NO.	NAME	DATE
1	PER IDOT	8-13-09
2	PER IDOT	10-29-09

**McBRIDE ENGINEERING, INC.**  
CIVIL ENGINEERS & SURVEYORS  
ILLINOIS PROFESSIONAL DESIGN FIRM #184-000803

CORPORATE: 3649 W. 183rd Street Suite 124  
Hazel Crest, IL 60429-2409  
708-799-1350

ARLINGTON HEIGHTS DIVISION: 320 S. Belmont Avenue  
Arlington Heights, IL 60005-2038  
847-394-4810

MEI PROJECT: 04119.806 SCALE: NONE

VILLAGE OF CRETE  
EXCHANGE STREET IMPROVEMENTS  
CRETE, WILL COUNTY, ILLINOIS

TYPICAL SECTIONS

DATE: 7-3-09

DRAWN BY: PG/ADM  
CHECKED BY: LGB

M:\2004\04119.4.dwg\04119.806\_COVER & DETAILS.dwg 10/29/2009 11:08:24 AM CDT