

## RECESSED REFLECTIVE PAVEMENT MARKERS

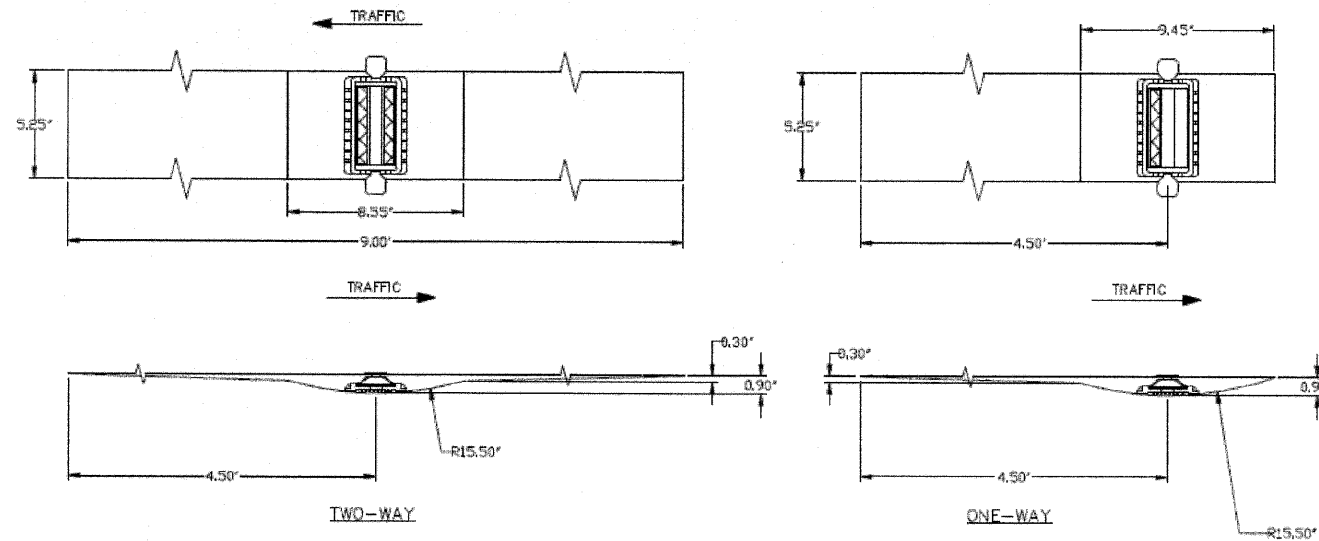

### PAVEMENT MARKINGS, SIGNING

RECESSED REFLECTIVE PAVEMENT MARKERS SHALL BE INSTALLED AS FOLLOWS:

- TWO (2) TWO-WAY AMBER RECESSED PAVEMENT MARKERS SHALL BE PLACED AT FORTY FEET (40') C-C ALONG DOUBLE YELLOW CENTERLINES AT INTERSECTIONS AND CURVES. IN TANGENT SECTIONS THE RECESSED PAVEMENT MARKERS WILL BE AT EIGHTY FEET (80') CENTERS.
- TWO (2) ONE-WAY CRYSTAL RECESSED MARKERS SHALL BE PLACED AT (10') APART AT (80') C-C ALONG LANE LINES BETWEEN WHITE DASHES AT INTERSECTIONS AND CURVES. IN TANGENT SECTIONS, ONLY ONE (1) CRYSTAL RECESSED PAVEMENT MARKERS SHALL BE PLACED AT (80') C-C.
- TURN BAY LINES SHALL HAVE ONE-WAY CRYSTAL MARKERS PLACED AT FORTY FEET (40') C-C.
- TWO-WAY AMBER MARKERS SHALL BE USED WHEN THE PAINTED MEDIAN IS LESS THAN OR EQUAL TO FOUR FEET (4') IN WIDTH; ONE-WAY AMBER MARKERS SHALL BE USED WHEN THE PAINTED MEDIAN IS GREATER THAN FOUR FEET (4') IN WIDTH.
- CRYSTAL/RED MARKERS SHALL BE PLACED AT LANE LINES AND TURN BAYS ON DIVIDED HIGHWAYS AND HIGHWAYS WITH RAISED MEDIANS.

TURNING LANES 150 TO 199 FEET SHALL HAVE AN ADDITIONAL ARROW PLACED PRIOR TO THE END OF THE TURN LANE.

TURNING LANES 200 FEET AND LONGER SHALL HAVE AN ADDITIONAL ARROW AND ONLY PLACED PRIOR TO THE END OF THE LANE.

SKIP DASHED AND YELLOW CENTERLINES SHALL BE GAPPED AT SIDE ROAD INTERSECTIONS. THE GAP SHALL BEGIN AND END AT A FORTY FOOT TO FORTY-FIVE FOOT RADIUS POINT FROM THE CENTERLINE OF THE SIDE ROAD.

ALL FOUR INCH (4") AND SIX INCH (6") LONGITUDINAL PAVEMENT MARKINGS SHALL BE THERMOPLASTIC.

CROSS WALK PAVEMENT MARKINGS SHALL BE INSTALLED AS FOLLOWS:

- TWO (2) SIX INCH (6") PARALLEL LINES SIX FOOT (6') APART SHALL BE USED ON SIDE ROADS AND AT SIGNALIZED INTERSECTIONS WITHOUT SCHOOL CROSSINGS.
- NEAR ALL SCHOOL AND NON-SIGNALIZED CROSS WALKS ACROSS COUNTY HIGHWAYS, A SERIES OF TWELVE INCH (12") WIDE, SIX FEET (6') LONG LINES AT TWENTY-FOUR INCH (24") C-C SPACING SHALL BE USED.
- ALL BICYCLE AND EQUESTRIAN PATH CROSSINGS SHALL INCLUDE TWO (2) TWELVE INCH (12") PARALLEL LINES AND A SERIES OF TWELVE INCH (12") WIDE LINES AT 45° AT THIRTY-SIX INCH (36") C-C SPACING.

TEMPORARY PAVEMENT MARKING DELINEATION SHALL BE AS FOLLOWS:

FOUR INCH (4") CENTERLINES, LANE LINES, TURN BAY LINES, PAINTED MEDIANS AND TWENTY-FOUR INCH (24") STOP BARS. THE MARKINGS SHALL BE PAINTED AND PLACED THE SAME DAY AS BITUMINOUS SURFACE REMOVAL.

TEMPORARY PAVEMENT MARKINGS SHALL USE A CONTINUOUS DOUBLE YELLOW LINE FOR THE CENTERLINE FOLLOWING BITUMINOUS SURFACE REMOVAL.

ALL SHORT TERM PAVEMENT MARKINGS WILL BE PLACED AS DIRECTED BY THE ENGINEER.

THE CONTRACTOR SHALL COORDINATE WITH THE DU PAGE COUNTY DOT FOR THE RELOCATION OF PERMANENT ROADWAY SIGNS DURING CONSTRUCTION.

## BUTT JOINT DETAILS

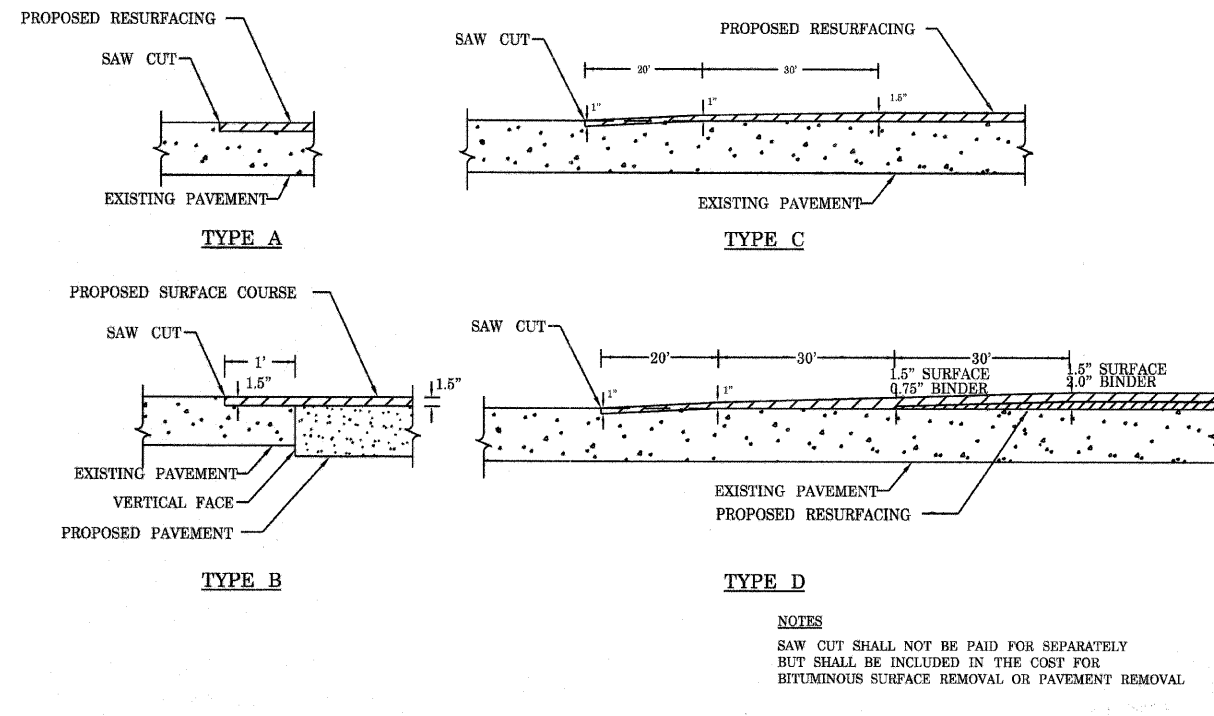

### NOTES

SAW CUT SHALL NOT BE PAID FOR SEPARATELY BUT SHALL BE INCLUDED IN THE COST FOR BITUMINOUS SURFACE REMOVAL OR PAVEMENT REMOVAL.

PRINTED DATE: 10/16/2009 10:00 AM PROJECT: 40 Details 13

NO.	DATE	DESCRIPTION OF REVISIONS	NO.	DATE	DESCRIPTION OF REVISIONS

ESI PROJECT NO. 09-260	ENGR. MR.
FILE: 40 Details 13	TECH: DN
DATE: 06-25-09	TECH: JJ
	QAQC: JS