

▨ - INDICATES PAVEMENT/SHOULDER TO BE REMOVED

▨ - INDICATES PAVEMENT/SHOULDER TO BE REMOVED

IF EXISTING GUARDRAIL IS WITHIN WIDENING LIMITS, CONSTRUCT WIDENING TO EXISTING GUARDRAIL IN PRE-STAGE 1 AND THE REMAINDER IN STAGE 2. OTHERWISE CONSTRUCT ALL WIDENING ON RT IN PRE-STAGE 1. (SEE EXISTING CROSS SECTIONS FOR LOCATIONS).

**PAVEMENT LEGEND**

1. EXISTING P.C.C. PAVEMENT, VARIES 6"-9"
2. EXISTING HOT MIX ASPHALT WIDENING 9"
3. EXISTING HOT MIX ASPHALT OVERLAY 4"
4. EXISTING HOT MIX ASPHALT SHOULDER 8"
5. EXISTING AGGREGATE SHOULDER 9"
6. EXISTING HOT MIX SURFACE COURSE 1 1/2"
7. EXISTING PRECAST CONCRETE BRIDGE BEAM
8. PROPOSED HOT MIX ASPHALT BINDER COURSE (VAR. DEPTH)
9. PROPOSED HOT MIX ASPHALT SURFACE COURSE, MIX "C", N50 (1 1/2" MIN.)
10. PROPOSED EARTH EMBANKMENT
11. PROPOSED PAVEMENT MARKING LINE - 5"
12. PROPOSED SUB-BASE GRANULAR MATERIAL, TYPE A (VARIABLE DEPTH)
13. PROPOSED AGGREGATE SHOULDERS, TYPE B (VAR. DEPTH)
14. PROPOSED CONCRETE BRIDGE APPROACH PAVEMENT
15. PROPOSED HOT MIX ASPHALT BASE COURSE, WIDENING 10"
16. PROPOSED LEVELING BINDER (MACHINE METHOD), N50 (3/4")
17. PROPOSED EARTH EXCAVATION
18. GUARDRAIL TEMPORARY/PERMANENT
19. PROPOSED HOT MIX ASPHALT SURFACE REMOVAL - BUTT JOINT
20. HOT MIX ASPHALT SHOULDER (VARIABLE DEPTH)

- (\*) PRIOR TO STARTING STAGE I, THE ENGINEER WILL EVALUATE THE EXISTING SHOULDER. WIDENING MAY BE OMITTED IF DETERMINED NOT NECESSARY BY THE ENGINEER
- (\*\*) SEE PLAN SHEETS FOR LIMITS

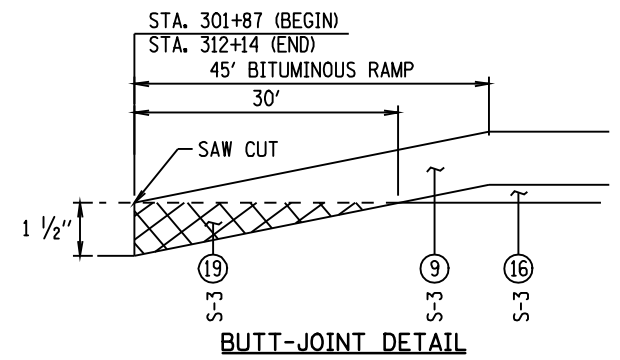

USER NAME: PLOT SCALE: PLOT DATE:	DESIGNED -	REVISED -	<b>STATE OF ILLINOIS                  DEPARTMENT OF TRANSPORTATION</b>	<b>TYPICAL SECTIONS 2 OF 2</b>				F.A.P. RTE.	SECTION	COUNTY	TOTAL SHEETS	SHEET NO.
	DRAWN -	REVISED -		717	109B-3	LOGAN	73	13				
	CHECKED -	REVISED -		CONTRACT NO. 72A88								
	DATE -	REVISED -		SCALE:	SHEET NO.	OF SHEETS	STA. TO STA.	FED. ROAD DIST. NO.	ILLINOIS	FED. AID PROJECT		