

**BUTT JOINT DETAIL**

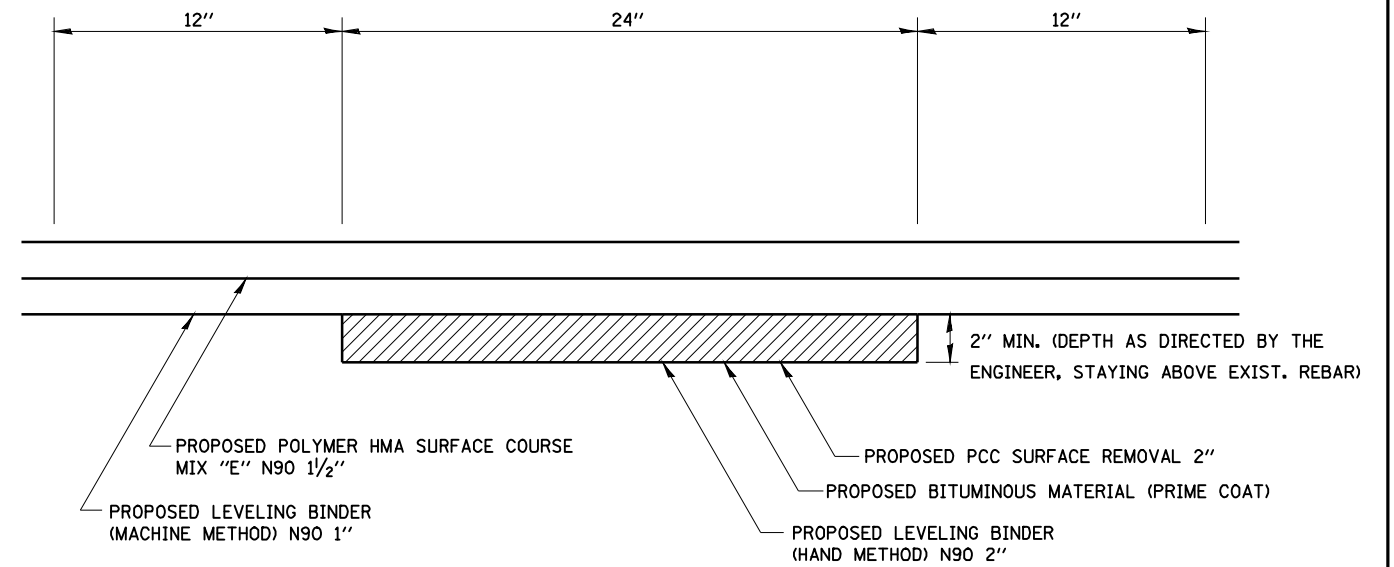

**(TYPICAL) PROPOSED LONGITUDINAL JOINT REPAIR DETAIL**

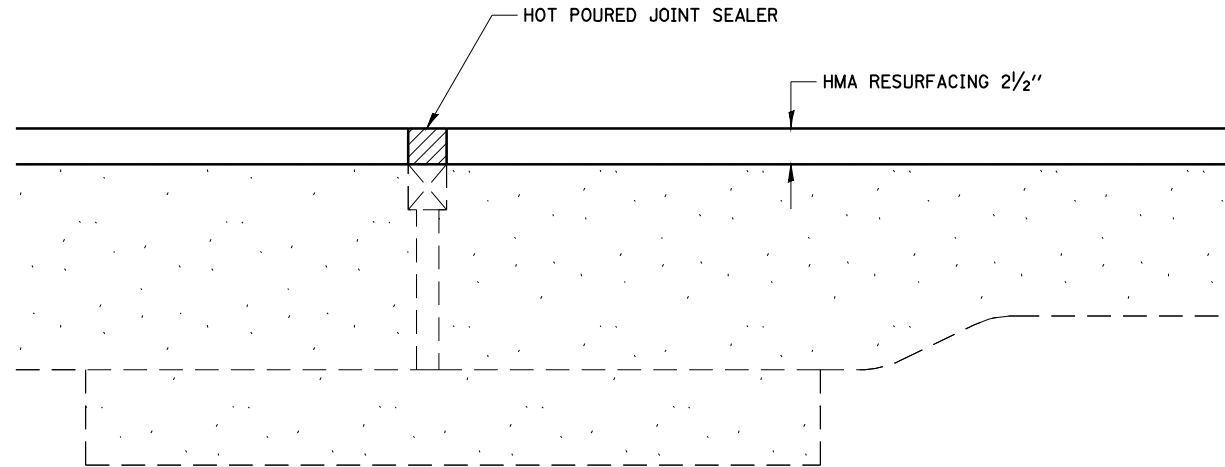

**PREFORMED JOINT SEAL TREATMENT SECTION A-A (AT PREFORMED JOINT)**

**NOTE:**

CONTRACTOR TO SURFACE OVER EXISTING PREFORMED JOINT SEALER. UPON COMPLETION OF RESURFACING, CONTRACTOR IS TO SAW CUT AT THE EDGE OF THE PJS AND REMOVE THE BITUMINOUS MATERIAL, COST TO BE INCLUDED WITH HMA RESURFACING ITEMS.

CONTRACTOR TO PLACE HOT POURED JOINT SEALER PER STANDARD SPECIFICATION 1050.02 OVER PJS, COST TO BE INCLUDED IN HMA RESURFACING ITEMS.

CONTRACTOR IS TO NOTE LOCATION OF PREFORMED JOINT SEAL PRIOR TO RESURFACING TO ALLOW EDGES TO BE IDENTIFIED FOR SAW CUT LOCATION.

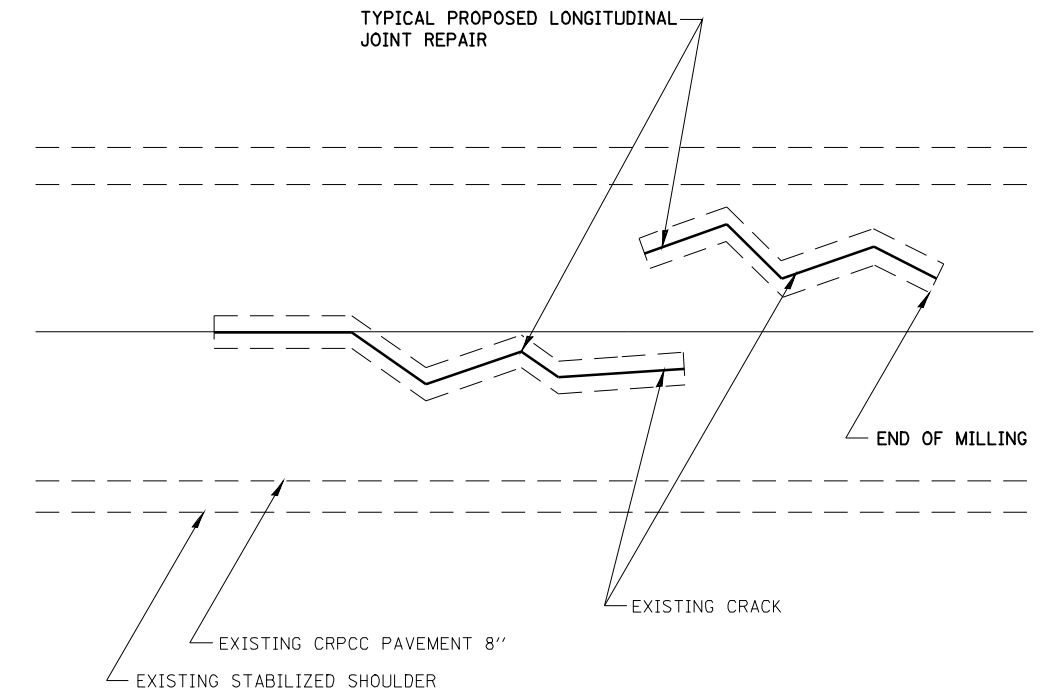

**PROPOSED LONGITUDINAL JOINT REPAIR PLAN VIEW**