

**TYPICAL SECTION #7**  
**FA 714**  
 STA. 209+38.98 TO STA. 217+67.24

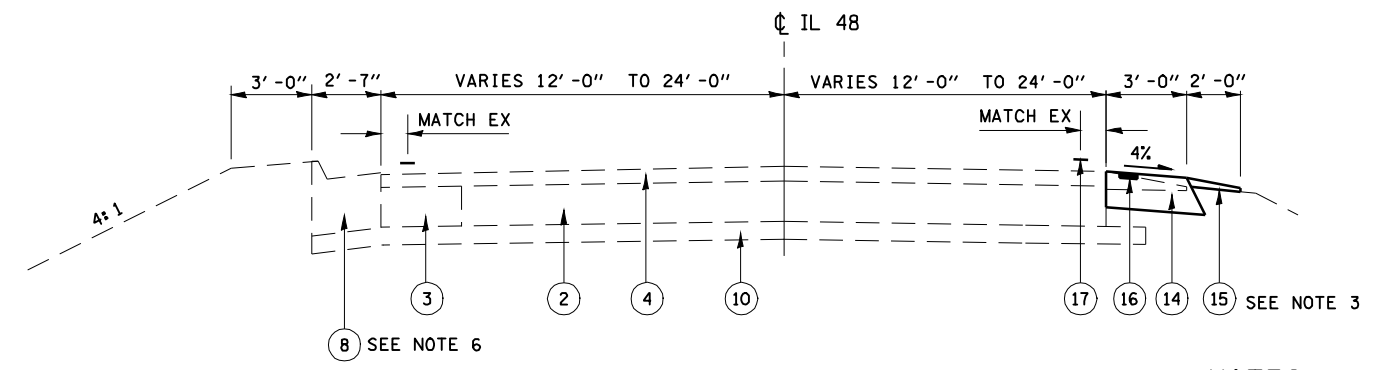

**TYPICAL SECTION #8**  
**FA 714**

STA. 185+62.50 TO STA. 188+05.74  
 STA. EQ. : STA. 188+05.74 BK. = STA. 188+02.67 AH.  
 STA. 188+02.67 TO STA. 196+70.00

**NOTES:**  
 3. LIMITS OF EXISTING CURB AND GUTTER:  
 RT. STA. 185+62.50 TO STA. 189+23.87  
 LT. STA. 187+13.00 TO STA. 190+04.00

**LEGEND**

- ① EXISTING 9" P. C. C. PAVEMENT
- ② EXISTING P. C. C. BASE COURSE 9"
- ③ EXISTING P. C. C. WIDENING
- ④ EXISTING HOT-MIX ASPHALT OVERLAY
- ⑤ EXISTING GUTTER, TYPE A
- ⑥ EXISTING HOT-MIX ASPHALT SHOULDER
- ⑦ EXISTING AGGREGATE SHOULDER, TYPE B
- ⑧ EXISTING CURB AND GUTTER
- ⑨ EXISTING CONCRETE MEDIAN SURFACE, 4"
- ⑩ EXISTING SUB-BASE GRANULAR MATERIAL
  
- ⑭ PROPOSED HOT-MIX ASPHALT SHOULDER 8"
- ⑮ PROPOSED AGGREGATE SHOULDERS, TYPE B ( WEDGE)
- ⑯ PROPOSED SHOULDER RUMBLE STRIP
- ⑰ PROPOSED THERMO PAVEMENT MARKING, 5"