

F.A.I. RTE.	SECTION	COUNTY	TOTAL SHEETS	SHEET NO.
72	66(B,HVB,HB-1)BR	MACON	83	1
FED. ROAD DIST. NO.	ILLINOIS	CONTRACT NO. 74343		

STATE OF ILLINOIS
DEPARTMENT OF TRANSPORTATION
DIVISION OF HIGHWAYS
**PROPOSED
HIGHWAY PLANS**

FOR INDEX OF SHEETS, SEE SHEET NO. 2

F.A.I. ROUTE 72
SECTION 66(B,HVB,HB-1)BR
PROJECT: *IM-072-1(080)150*
MACON COUNTY
C-97-112-08

D-97-059-08

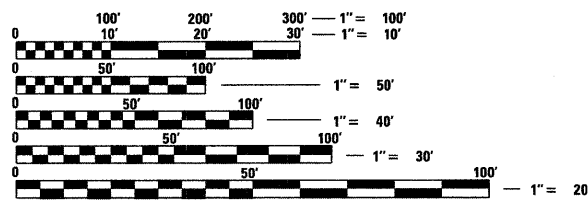
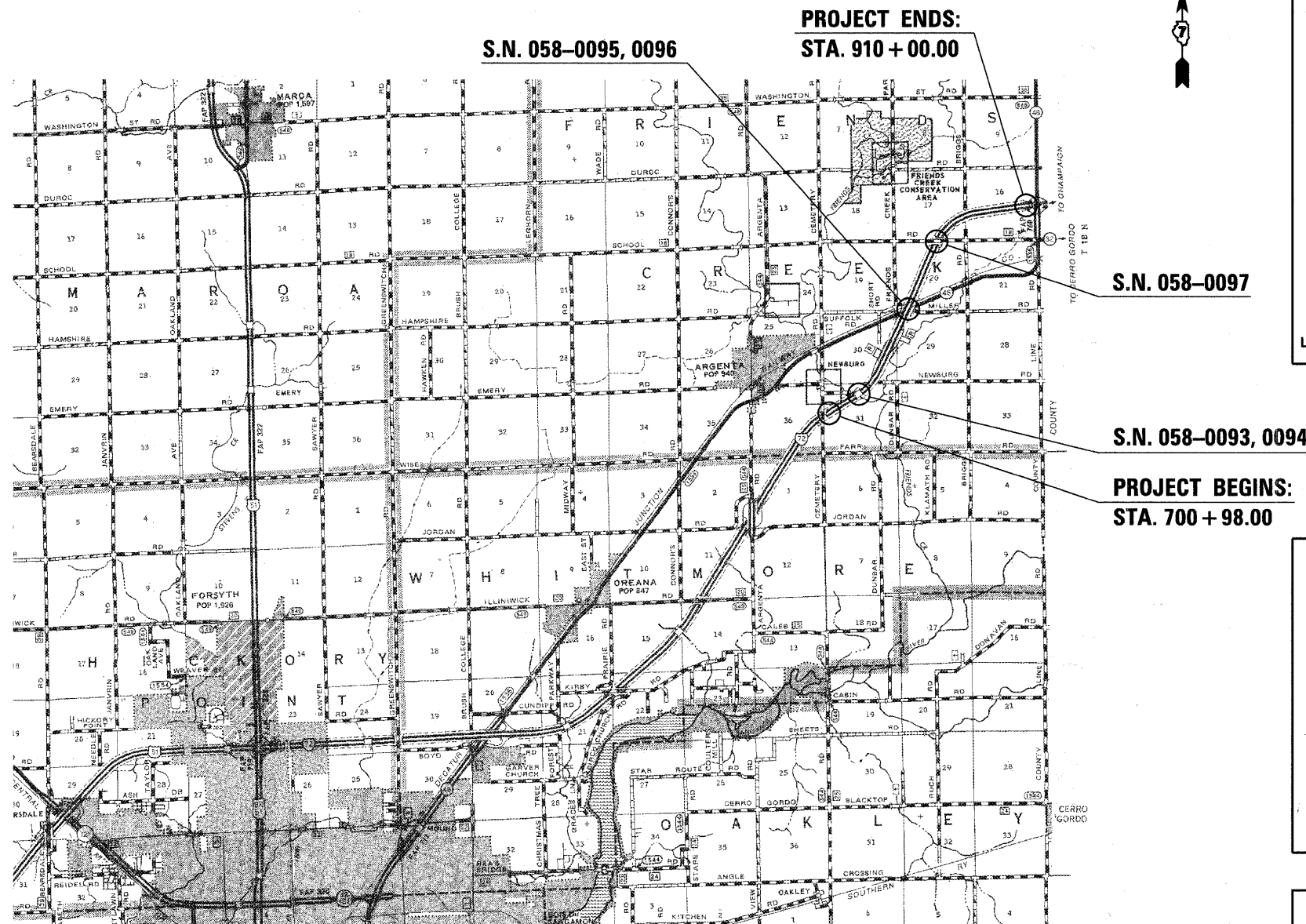
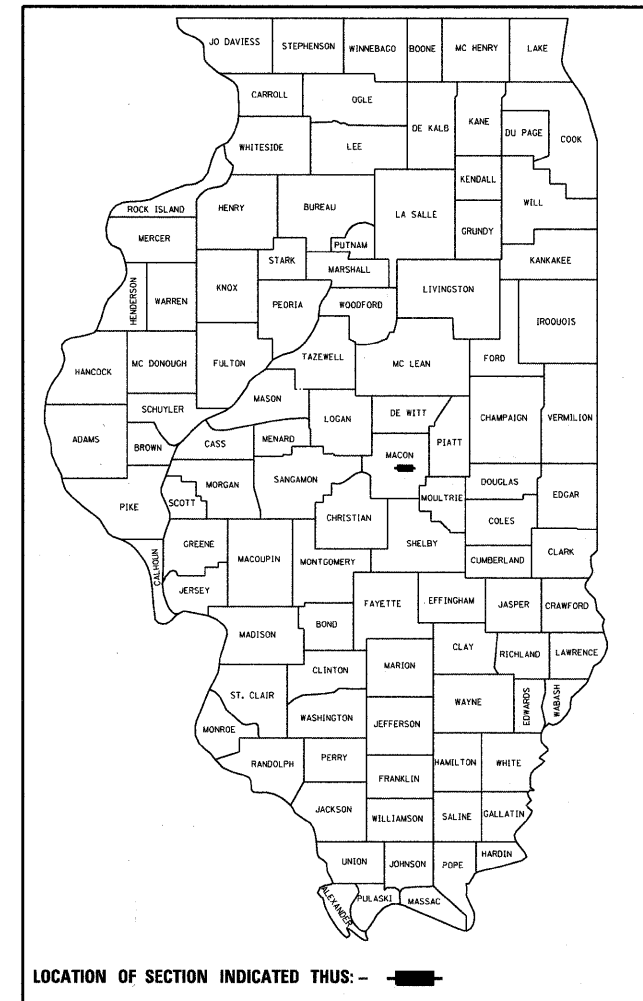

FULL SIZE PLANS HAVE BEEN PREPARED USING STANDARD ENGINEERING SCALES. REDUCED SIZED PLANS WILL NOT CONFORM TO STANDARD SCALES. IN MAKING MEASUREMENTS ON REDUCED PLANS, THE ABOVE SCALES MAY BE USED.

J.U.L.I.E.
JOINT UTILITY LOCATION INFORMATION FOR EXCAVATION
1-800-892-0123
OR 811

TOWNSHIP: FRIENDS CREEK
PROJECT ENGINEER - TOM RONAN
PROJECT MANAGER - JEFF DAVISON
ADT = 10,533
CONTRACT NO. 74343

GROSS LENGTH = 20,902 FT. = 3.96 MI.
NET LENGTH = 20,902 FT. = 3.96 MI.

STATE OF ILLINOIS
DEPARTMENT OF TRANSPORTATION
DIVISION OF HIGHWAYS

SUBMITTED *October 1, 20 09*

Roger E. Shickell
DEPUTY DIRECTOR OF HIGHWAYS, REGION ENGINEER

December 4, 20 09
Charles G. Ingersoll
ENGINEER OF DESIGN AND ENVIRONMENT

December 4, 20 09
Christine M. Reed
DIRECTOR OF HIGHWAYS, CHIEF ENGINEER

**PRINTED BY THE AUTHORITY
OF THE STATE OF ILLINOIS**

INDEX OF SHEETS

1	COVER SHEET
2	INDEX OF SHEETS & STANDARDS
3	GENERAL NOTES
4-5	SUMMARY OF QUANTITIES
6	TYPICAL SECTIONS
7-9	SCHEDULE OF QUANTITIES
10-12	ROADWAY PLAN SHEETS
13-26	TRAFFIC CONTROL STAGING SHEETS
27	PAVEMENT MARKING DETAILS
28-82	BRIDGE REPAIR SHEETS
83	DETAIL SHEET

STANDARDS IN THE PLANS

000001-05	STANDARD SYMBOLS, ABBREVIATIONS AND PATTERNS
001001-02	AREAS OF REINFORCEMENT BARS
001006	DECIMAL OF AN INCH AND OF A FOOT
420401-08	BRIDGE APPROACH PAVEMENT CONNECTOR
601001-03	SUB-SURFACE DRAINS
601101-01	CONCRETE HEADWALL FOR PIPE DRAIN
630001-08	STEEL PLATE BEAM GUARDRAIL
630301-05	SHOULDER WIDENING FOR TYPE 1 (SPECIAL) GUARDRAIL TERMINALS
631031-08	TRAFFIC BARRIER TERMINAL, TYPE 6
635006-03	REFLECTOR AND TERMINAL MARKER PLACEMENT
635011-02	REFLECTOR MARKER AND MOUNTING DETAILS
701101-02	OFF-ROAD OPERATIONS, MULTILANE, 4.5m (15') TO 600mm (24')
701316-04	LANE CLOSURE, 2L, 2W, BRIDGE REPAIR FOR SPEEDS >45 MPH
701400-07	APPROACH TO LANE CLOSURE, FREEWAY/EXPRESSWAY
701402-07	LANE CLOSURE, FREEWAY/EXPRESSWAY WITH BARRIER
701411-06	LANE CLOSURE, MULTILANE, AT ENTRANCE OR EXIT RAMP FOR SPEEDS >45 MPH
701426-03	LANE CLOSURE, MULTILANE, INTERMITTENT OR MOVING OPERATIONS FOR SPEEDS >45 MPH
701901-01	TRAFFIC CONTROL DEVICES
704001-06	TEMPORARY CONCRETE BARRIER

FILE NAME =	USER NAME = swartzrw	DESIGNED -	REVISED -	STATE OF ILLINOIS DEPARTMENT OF TRANSPORTATION	INDEX OF SHEETS & STANDARDS IN THE PLANS	F.A.I RTE.	SECTION	COUNTY	TOTAL SHEETS	SHEET NO.	
es:\pw_work\PWIDOT\SWARTZRW\dms37771\sh	index.74343.dgn	DRAWN -	REVISED -			72	66(B,HVB,HB-1)BR	MACON	83	2	
	PLOT SCALE = 48,0000 / IN.	CHECKED -	REVISED -			SCALE: NA		SHEET NO. 1 OF 1 SHEETS		STA. TO STA.	
	PLOT DATE = 9/23/2009	DATE -	REVISED -			FED. ROAD DIST. NO.		ILLINOIS FED. AID PROJECT			
						CONTRACT NO. 74343					

GENERAL NOTES

THIS SECTION SHALL BE CONSTRUCTED IN ACCORDANCE WITH THE PLANS, THE "STANDARD SPECIFICATIONS FOR ROAD AND BRIDGE CONSTRUCTION", ADOPTED JANUARY 1, 2007; THE "SUPPLEMENTAL SPECIFICATIONS AND RECURRING SPECIAL PROVISIONS" INDICATED ON THE CHECK SHEET, AND "THE SPECIAL PROVISIONS" INCLUDED IN THE PROPOSAL.

THE WORK IN SECTION 66(B,HVB,HB-1)BR INCLUDES PATCHING AND JOINT REPAIR, HYDROSCARIFICATION AND MICROSILICA OVERLAY TO S.N. 058-0093/0094, 058-0095/0096 AND 058-0097, ALSO REPLACEMENT OF PIPE UNDERDRAIN OUTLETS AND GUARDRAIL CONSTRUCTION AND OTHER WORK NECESSARY TO COMPLETE THIS SECTION.

PLAN DIMENSIONS AND DETAILS RELATIVE TO THE EXISTING STRUCTURE HAVE BEEN TAKEN FROM EXISTING PLANS AND ARE SUBJECT TO NOMINAL CONSTRUCTION VARIATIONS. IT SHALL BE THE CONTRACTOR RESPONSIBILITY TO VERIFY SUCH DIMENSIONS AND DETAILS IN THE FIELD AND MAKE NECESSARY APPROVED ADJUSTMENTS PRIOR TO THE CONSTRUCTION OR ORDERING OF MATERIAL. SUCH VARIATIONS SHALL NOT BE CAUSE FOR ADDITIONAL COMPENSATION OR A CHANGE IN THE SCOPE OF THE WORK. THE CONTRACTOR WILL BE PAID FOR THE QUANTITY ACTUALLY FURNISHED AT THE UNIT PRICE BID FOR THE WORK.

THE PROPOSED PROJECT BEGINS APPROXIMATELY 1.8 MILES EAST OF ARGENTA AND EXTENDS IN AN EASTERLY DIRECTION A DISTANCE OF 3.80 MILES.

ALL ELEVATIONS SHOWN IN PLANS ARE BASED ON U.S.G.S. DATUM.

ALL DISTURBED AREAS WITHIN THE CONSTRUCTION LIMITS SHALL BE FERTILIZED AND SEEDED. SEEDING SHALL BE CLASS 2 (SPECIAL) IN ACCORDANCE WITH THE SPECIAL PROVISIONS AND THE APPLICABLE ARTICLES OF SECTION 250 OF THE STANDARD SPECIFICATIONS.

IN ADDITION TO THE REQUIREMENTS FOR PORTABLE CHANGEABLE MESSAGE SIGNS IN ARTICLE 701.15(I), A LAPTOP COMPUTER SHALL ALSO BE SUPPLIED BY THE CONTRACTOR.

THE TYPE E AND TYPE F SHOULDER INLETS FROM STATIONS LT. 707+50 TO LT. 718+19.60 AND FROM STATION RT. 715+00 TO RT. 718+82.60, SHALL BE PROTECTED FROM STAGE TRAFFIC IN A MANNER APPROVED BY THE ENGINEER.

EXISTING PERMANENT PAVEMENT MARKINGS THAT ARE IN CONFLICT WITH ANY TEMPORARY PAVEMENT MARKINGS SHALL BE COVERED AND PRESERVED UNTIL THE CONSTRUCTION IS COMPLETED.

THE COST OF INSTALLATION AND REMOVAL OF ALL TEMPORARY PAVEMENT MARKING UTILIZED WITH TRAFFIC CONTROL AND PROTECTION STANDARD 701402 (SPECIAL), TRAFFIC CONTROL AND PROTECTION STANDARD 701411 AND TRAFFIC CONTROL AND PROTECTION STANDARD 701316 SHALL BE CONSIDERED INCLUDED IN THOSE TRAFFIC CONTROL STANDARDS.

PREFORMED PLASTIC PAVEMENT MARKING, TYPE B - LINE 4" AND 6" SHALL BE GROOVED-IN ACCORDING TO THE APPLICABLE SPECIAL PROVISIONS.

FILE NAME =	USER NAME = swartzrw	DESIGNED -	REVISED -	STATE OF ILLINOIS DEPARTMENT OF TRANSPORTATION	GENERAL NOTES	F.A.I RTE.	SECTION	COUNTY	TOTAL SHEETS	SHEET NO.	
ct:\pw\work\PWIDOT\SWARTZRW\dms37771\sh	index_74343.dgn	DRAWN -	REVISED -			72	66(B,HVB,HB-1)BR	MACON	83	3	
	PLOT SCALE = 20.0000' / 1" IN.	CHECKED -	REVISED -			CONTRACT NO. 74343					
	PLOT DATE = 9/28/2009	DATE -	REVISED -			SCALE: NA	SHEET NO. 1	OF 1	SHEETS	STA.	TO STA.

SUMMARY OF QUANTITIES (Cont'd)				CONSTRUCTION TYPE CODES					
CODE NO	ITEM	UNIT	90% FED. 10% STATE TOTAL QUANTITIES	SN 058-0093	SN 058-0094	SN 058-0095	SN 058-0096	SN 058-0097	ROADWAY
				SFTY-2A	SFTY-2A	SFTY-2A	SFTY-2A	SFTY-2A	I000
63200305	STEEL PLATE BEAM GUARD RAIL REMOVAL	FOOT	1368.5	220.7	395.1	376.5	376.2		
67000400	ENGINEER'S FIELD OFFICE, TYPE A	CAL MO	6	1.2	1.2	1.2	1.2	1.2	
67100100	MOBILIZATION	L SUM	1	0.2	0.2	0.2	0.2	0.2	
70100100	TRAFFIC CONTROL AND PROTECTION, STANDARD 701316	EACH	1					1	
70101220	TRAFFIC CONTROL AND PROTECTION, STANDARD 701411 (SPECIAL)	EACH	4	1	1	1	1		
70103815	TRAFFIC CONTROL SURVEILLANCE	CAL DA	2					2	
70106500	TEMPORARY BRIDGE TRAFFIC SIGNALS	EACH	2					2	
70400100	TEMPORARY CONCRETE BARRIER	FOOT	2475	625	625	637.5	587.5		
70400200	RELOCATE TEMPORARY CONCRETE BARRIER	FOOT	2475	625	625	637.5	587.5		
* 78003110	PREFORMED PLASTIC PAVEMENT MARKING, TYPE B - LINE 4"	FOOT	3435	826	847	883	879		
* 78003130	PREFORMED PLASTIC PAVEMENT MARKING, TYPE B - LINE 6"	FOOT	429	103	106	110	110		
* 78100105	RAISED REFLECTIVE PAVEMENT MARKER (BRIDGE)	EACH	43	10	11	11	11		
* 78200410	GUARDRAIL MARKERS, TYPE A	EACH	54	15	23	8	8		
* 78201000	TERMINAL MARKER - DIRECT APPLIED	EACH	7	1	2	2	2		
X0301271	REMOVE EXISTING UNDERDRAINS	FOOT	1191.5						1191.5
X0321468	PLUG EXISTING DECK DRAINS	EACH	174	33	33	46	46	16	
X0323644	PAVEMENT MARKING GROOVING	FOOT	3864	929	953	993	989		
X0323988	TEMPORARY SOIL RETENTION SYSTEM	SQ FT	70			70			
X0325305	STRUCTURAL REPAIR OF CONCRETE (DEPTH EQUAL TO OR LESS THAN 5 INCHES)	SQ FT	888	121	167	266	193	141	
X0325983	BRIDGE DECK FLY ASH OR GGBF SLAG CONCRETE OVERLAY, 2 1/4"	SQ YD	899					899	
X0349800	CONCRETE HEADWALL FOR PIPE UNDERDRAIN REMOVAL	EACH	142						142
X7010820	TRAFFIC CONTROL AND PROTECTION, STANDARD 701402 (SPECIAL)	L SUM	1	0.25	0.25	0.25	0.25		
X7015005	CHANGEABLE MESSAGE SIGN	CAL DA	28	7	7	7	7		
XZ193500	BRIDGE DECK MICROSILICA CONCRETE OVERLAY 2 1/4"	SQ YD	6501	1740	1749	1506	1506		
Z0006204	BRIDGE DECK HYDRO-SCARIFICATION 1/2"	SQ YD	7400	1740	1749	1506	1506	899	
Z0016001	DECK SLAB REPAIR (FULL DEPTH, TYPE I)	SQ YD	38	7	7	10	10	4	
Z0016002	DECK SLAB REPAIR (FULL DEPTH, TYPE II)	SQ YD	117	10	18	26	32	31	
Z0030240	IMPACT ATTENUATORS, TEMPORARY (NON- REDIRECTIVE), TEST LEVEL 2	EACH	4	1	1	1	1		
Z0030340	IMPACT ATTENUATORS, RELOCATE (NON- REDIRECTIVE), TEST LEVEL 2	EACH	4	1	1	1	1		
Z0048665	RAILROAD PROTECTIVE LIABILITY INSURANCE	L SUM	1			0.5	0.5		
⓪ Z0076600	TRAINEES	HOUR	500	100	100	100	100	100	

* Specialty Items
© Y080

FILE NAME =	USER NAME = swartzw	DESIGNED - JLD	REVISED -	STATE OF ILLINOIS DEPARTMENT OF TRANSPORTATION	SUMMARY OF QUANTITIES				F.A.I RTE.	SECTION	COUNTY	TOTAL SHEETS	SHEET NO.
cs:\pw_work\p\dot\swartzw\dms37771\shstsq.74343.dgn	DRAWN - RWS	REVISED -	72						66(B,HVB,HB-1)BR	MACON	83	5	
PLOT SCALE = 100,0000' / IN.	CHECKED - WES	REVISED -	SCALE: NA				SHEET NO. 2 OF 2 SHEETS	STA.	TO STA.	CONTRACT NO. 74343			
PLOT DATE = 10/7/2009	DATE - 10-07	REVISED -	FED. ROAD DIST. NO. ILLINOIS FED. AID PROJECT										

EXISTING TYPICAL CROSS SECTION

STA. 700+98 TO STA. 910+00

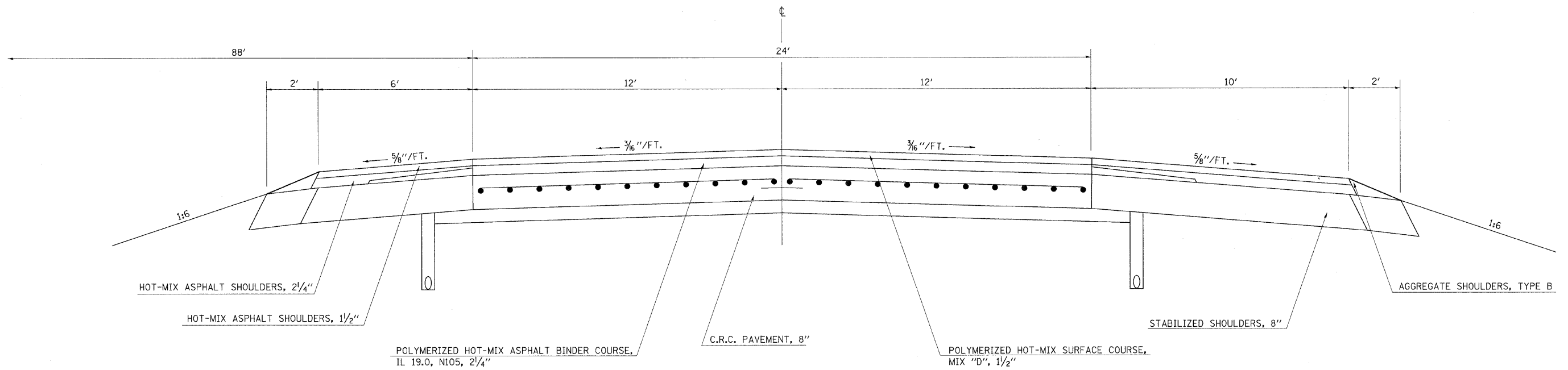

SHOULDER DETAIL

RT. STA. 715+00 TO RT. STA. 718+82.60
LT. STA. 707+50 TO LT. STA. 718+19.60

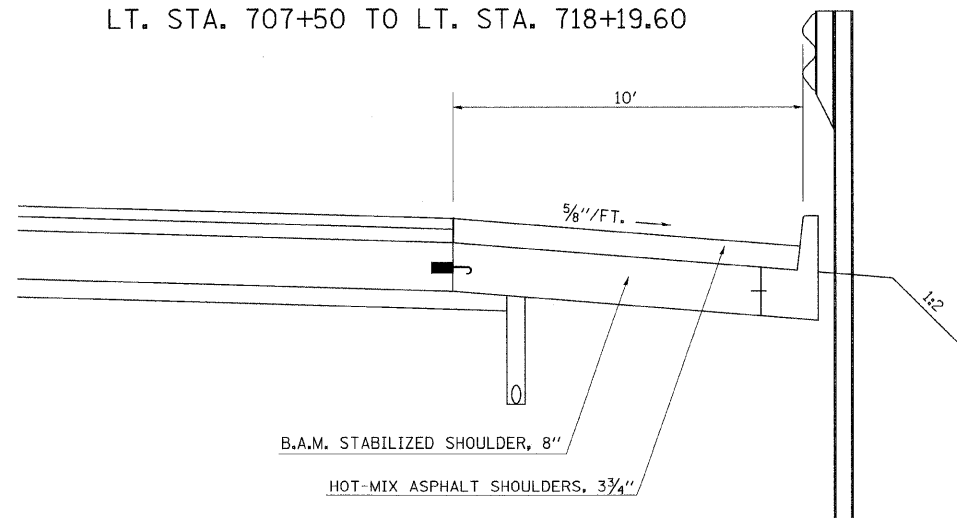

SHOULDER DETAIL

RT. STA. 711+00 TO RT. STA. 715+00

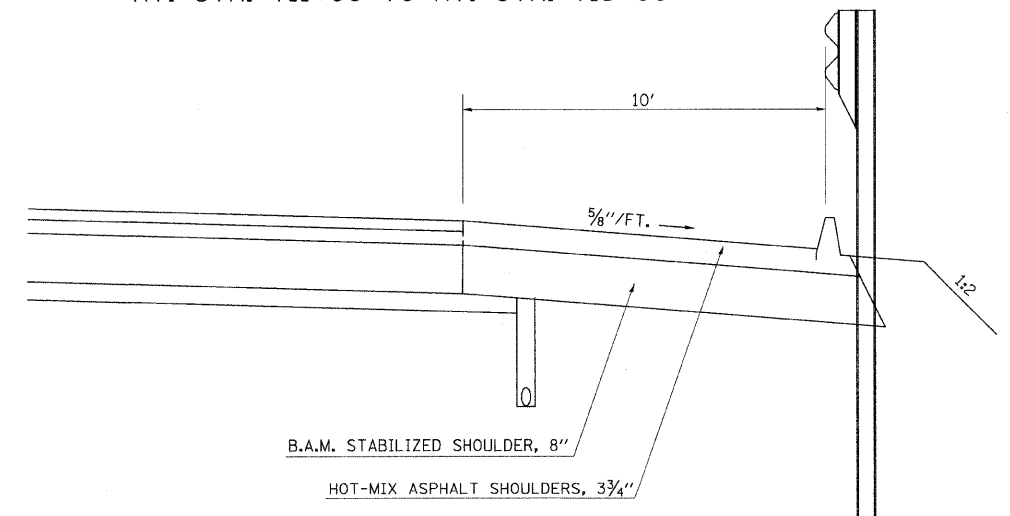

FILE NAME =	USER NAME = swartzw	DESIGNED -	REVISED -
c:\pw_work\PWIDOT\SWARTZRW\dms37771\sh	typical.74343.dgn	DRAWN -	REVISED -
	PLOT SCALE = 20.0000' / IN.	CHECKED -	REVISED -
	PLOT DATE = 9/28/2009	DATE -	REVISED -

**STATE OF ILLINOIS
DEPARTMENT OF TRANSPORTATION**

TYPICAL CROSS SECTIONS

SCALE: NA SHEET NO. 1 OF 1 SHEETS STA. TO STA.

F.A.I. RTE.	SECTION	COUNTY	TOTAL SHEETS	SHEET NO.
72	66(B,HVB,HB-1)BR	MACON	83	6
FED. ROAD DIST. NO. ILLINOIS FED. AID PROJECT			CONTRACT NO. 74343	

TRAFFIC BARRIER TERMINAL, TYPE 6 (SPECIAL)

LOCATION				NO.
				(EACH)
LT.	718+06.15	TO	718+52.43	1.0
RT.	718+92.83	TO	719+37.86	1.0
TOTAL =				2.0

GUARDRAIL MARKER, TYPE A

STATION	TO	STATION	LOCATION	EACH	(COLOR)
706+53.59		725+06.94	LT. SHLD	19.0	CRYSTAL
710+88.00		718+83.09	RT. SHLD	11.0	CRYSTAL
716+45.52		718+75.03	RT. MED	4.0	AMBER
723+42.10		725+82.28	LT. MED	4.0	AMBER
794+93.87		797+33.87	RT. MED	4.0	AMBER
795+26.98		797+66.98	RT. SHLD	4.0	CRYSTAL
800+68.69		803+08.69	LT. SHLD	4.0	CRYSTAL
801+01.74		803+41.74	LT. MED	4.0	AMBER
				TOTAL =	54.0
				TOTAL CRYSTAL	38.0
				TOTAL AMBER	16.0

TRAFFIC BARRIER TERMINAL, TYPE 6

LOCATION				NO.
				(EACH)
RT. MEDIAN	718+70.98	TO	719+37.86	1.0
LT.	722+88.40	TO	723+34.67	1.0
LT. MEDIAN	723+09.61	TO	723+53.04	1.0
RT. MEDIAN	797+20.45	TO	797+66.09	1.0
RT.	797+66.80	TO	798+12.45	1.0
LT.	800+23.21	TO	800+68.86	1.0
LT. MEDIAN	800+69.57	TO	801+15.21	1.0
TOTAL =				7.0

STEEL PLATE BEAM GUARD RAIL, REMOVAL

LOCATION				LENGTH
				(FEET)
LT.	718+06.15	TO	718+55.92	49.8
MEDIAN	717+46.03	TO	719+13.85	167.8
RT.	718+92.83	TO	719+45.78	52.9
LT.	722+82.74	TO	724+41.00	158.3
MEDIAN	723+09.61	TO	724+96.57	187.0
MEDIAN	795+72.00	TO	797+63.59	191.6
RT.	796+25.00	TO	798+09.94	184.9
LT.	800+25.71	TO	802+14.00	188.3
MEDIAN	800+72.07	TO	802+60.00	187.9
TOTAL =				1368.5

TERMINAL MARKER-DIRECT APPLIED

LOCATION	STATION	EACH
RT. MEDIAN	716+35.52	1.0
LT. SHLD	723+85.38	1.0
LT. MEDIAN	725+91.00	1.0
RT. MEDIAN	794+83.87	1.0
RT. SHLD	797+16.98	1.0
LT. SHLD	801+18.69	1.0
LT. MEDIAN	803+51.74	1.0
TOTAL =		7.0

PIPE UNDERDRAIN & HEADWALL SCHEDULE

(Length of Pipe Underdrain Removal and Installation of new Pipe underdrain is from edge of bituminous shoulder to headwall)

Location	Station (Headwalls)	Pipe U.D. (Foot)
Right median	703+70	9.0
Left median	703+70	9.0
Right shoulder	704+70	8.5
Right median	708+80	9.0
Left median	708+80	9.0
Left median	713+50	9.0
Right median	714+00	8.5
Right median	718+50	11.5
Left median	718+50	9.0
Left median	724+20	9.0
Right median	728+25	9.0
Left shoulder	728+40	7.0
Left median	729+35	9.0
Left median	734+40	9.0
Left shoulder	734+50	7.0
Right shoulder	735+00	7.0
Right median	735+00	9.0
Left shoulder	739+50	11.0
Right median	740+10	9.0
Right shoulder	740+75	8.0
Left median	741+05	9.0
Left shoulder	744+50	10.5
Right median	745+15	9.0
Left median	746+20	9.0
Right shoulder	747+35	8.0
Right median	750+35	9.0
Left median	751+20	9.0
Right shoulder	753+70	6.5
Left shoulder	755+00	16.5
Right median	755+40	9.0
Left median	756+15	9.0
Right shoulder	759+00	7.0
Right median	760+50	9.0
Right median	761+15	9.0
Right shoulder	764+30	10.5
Left shoulder	765+00	7.0
Right median	765+50	9.0
Left median	766+15	9.0
Right shoulder	769+75	10.5
Left shoulder	770+50	12.0
Left median	771+50	9.0
Right median	772+50	9.0
Right shoulder	775+40	7.5
Left median	776+25	9.0
Right median	777+75	9.0
Right shoulder	779+40	7.0
Right median	781+10	9.0
Left median	781+45	9.0
Left shoulder	781+45	7.0
Column Total		439.5

Right median	786+25	9.0
Right shoulder	786+30	12.0
Left shoulder	786+20	7.0
Left median	786+50	9.0
Right median	791+30	9.0
Left median	791+45	8.5
Left shoulder	791+45	7.0
Right shoulder	791+50	9.0
Left shoulder	805+25	7.0
Left median	805+50	9.0
Right shoulder	805+60	7.5
Right median	805+60	9.0
Right shoulder	808+50	7.0
Right median	808+50	9.0
Left median	810+70	8.5
Left shoulder	810+70	6.5
Right shoulder	813+40	7.0
Right median	813+40	9.0
Left shoulder	816+60	6.5
Left median	816+65	9.0
Left shoulder	818+85	7.0
Left median	818+90	9.0
Right median	819+00	9.0
Right shoulder	819+00	6.5
Right median	823+50	9.0
Right shoulder	823+50	7.0
Left shoulder	823+95	7.0
Left median	824+00	9.0
Right shoulder	828+60	7.0
Right median	828+75	9.0
Left shoulder	829+15	7.0
Left median	829+25	8.5
Right shoulder	833+70	7.0
Right median	833+75	9.0
Left shoulder	834+30	7.0
Left median	834+50	8.5
Right shoulder	837+40	7.5
Right median	838+75	9.0
Left shoulder	839+15	7.5
Left median	839+20	8.5
Right shoulder	842+30	7.0
Right median	843+75	9.0
Left shoulder	844+25	7.5
Left median	845+25	8.5
Right shoulder	846+90	6.0
Right median	848+75	9.0
Left median	849+40	8.5
Left shoulder	849+40	7.5
Right shoulder	851+95	6.5
Left median	858+00	8.5
Left shoulder	858+00	7.5
Column Total		410.0

Right median	859+00	9.0
Right shoulder	861+70	7.0
Left median	863+20	8.0
Left shoulder	863+20	8.0
Right median	864+00	9.0
Right shoulder	867+25	7.0
Left median	867+50	9.0
Left shoulder	867+50	8.0
Right median	869+00	9.0
Left median	871+75	9.0
Left shoulder	871+75	8.0
Right shoulder	872+30	7.0
Right median	874+20	9.0
Left median	876+00	9.0
Left shoulder	876+00	8.0
Right shoulder	877+50	6.0
Right median	879+25	9.0
Left median	880+00	9.0
Left shoulder	880+00	7.5
Right shoulder	883+40	7.5
Left median	883+80	9.0
Left shoulder	883+80	8.0
Right median	884+20	9.0
Left median	887+50	9.0
Left shoulder	887+50	7.5
Right shoulder	887+60	7.5
Right median	889+40	9.0
Left median	891+00	9.0
Right shoulder	892+50	7.0
Left shoulder	892+50	7.5
Right median	894+50	8.5
Right shoulder	897+50	7.0
Left shoulder	897+70	7.0
Right median	899+50	8.5
Right shoulder	902+50	7.0
Left median	902+50	8.5
Left shoulder	902+50	8.0
Right median	905+00	8.5
Right shoulder	907+50	7.5
Left median	907+50	9.0
Left shoulder	907+50	8.0
Right median	910+00	9.0
Column Total		342.0
Project Totals	*142	**1191.5

THESE TOTALS ARE FOR THE FOLLOWING PAY ITEMS:
 *CONCRETE HEADWALLS FOR PIPE DRAINS
 CONCRETE HEADWALL FOR PIPE UNDERDRAIN REMOVAL
 **PIPE UNDERDRAINS 4" (SPECIAL)
 REMOVE EXISTING UNDERDRAINS

BRIDGE APPROACH PAVEMENT REMOVAL

	LOCATION	LENGTH FEET	WIDTH FEET	AREA SQ YD
RT.	801+86.00 TO 802+26.00	40.0	36.5	162.2
PROJECT TOTAL				162.2

PAVED SHOULDER REMOVAL

	LOCATION	LENGTH FEET	WIDTH FEET	AREA SQ YD
RT. MEDIAN	801+51.52 TO 801+58.42	6.9	6.0	2.3
	801+58.42 TO 802+33.68	75.3	6.0	50.2
RT. SHOULDER	801+86.00 TO 801+97.68	11.7	10.0	6.5
	801+97.68 TO 802+33.68	36.0	10.0	40.0
PROJECT TOTAL				99.0

PAVEMENT REMOVAL

	LOCATION	LENGTH FEET	WIDTH FEET	AREA SQ YD
RT. MED	801+72.20 TO 802+26.00	35.3	24.0	47.1
RT. SHLD	802+26.00 TO 802+33.68	7.7	24.0	20.5
PROJECT TOTAL				67.6

FILE NAME = c:\pw\work\PWIDOT\SWARTZRW\dms3771\shch_74343.dgn	USER NAME = swartzrw	DESIGNED - JLD	REVISED -
PLOT SCALE = 20,0000' / IN.		DRAWN - RWS	REVISED -
PLOT DATE = 9/28/2009		CHECKED - WES	REVISED -
		DATE - 10-07	REVISED -

STATE OF ILLINOIS
DEPARTMENT OF TRANSPORTATION

SCHEDULE OF QUANTITIES	
SCALE: NA	SHEET NO. 3 OF 3 SHEETS STA. TO STA.

F.A.I. RTE. 72	SECTION 66(B,HV,B,H)-1BR	COUNTY MACON	TOTAL SHEETS 83	SHEET NO. 9
CONTRACT NO. 74343				
FED. ROAD DIST. NO. ILLINOIS FED. AID PROJECT				

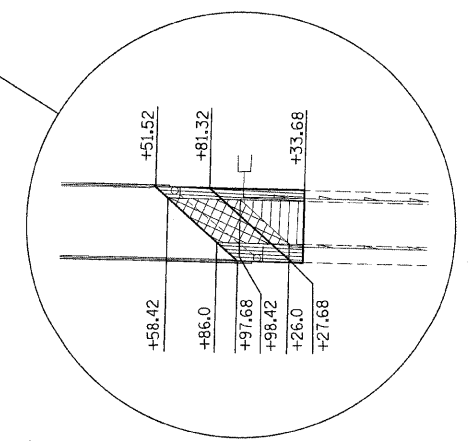
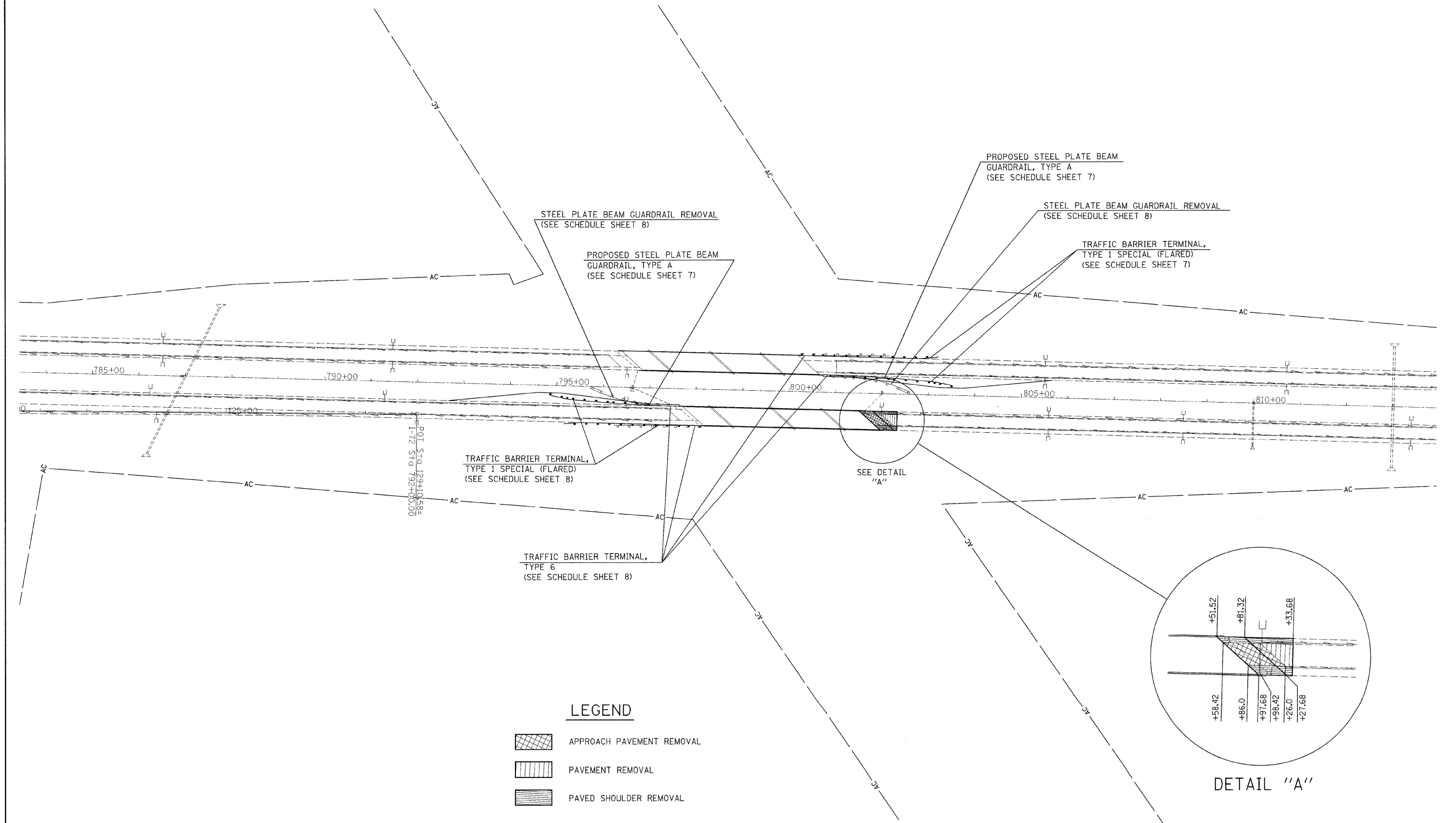

DETAIL "A"

LEGEND

- APPROACH PAVEMENT REMOVAL
- PAVEMENT REMOVAL
- PAVED SHOULDER REMOVAL

FILE NAME =	USER NAME = swartzw	DESIGNED -	REVISED -
ct:\p\work\PWIDOT\SWARTZRW\dms37771\olshplan_74343.dgn		DRAWN -	REVISED -
	PLOT SCALE = 100.0000' / 1" IN.	CHECKED -	REVISED -
	PLOT DATE = 9/28/2009	DATE -	REVISED -

**STATE OF ILLINOIS
DEPARTMENT OF TRANSPORTATION**

PLAN SHEET

SCALE: 100 SHEET NO. 2 OF 3 SHEETS STA. 784+00 TO STA. 813+00

F.A.I. RTE.	SECTION	COUNTY	TOTAL SHEETS	SHEET NO.
72	66(B,HVB,HB-1)BR	MACON	83	11
CONTRACT NO. 74343				
FED. ROAD DIST. NO. ILLINOIS FED. AID PROJECT				

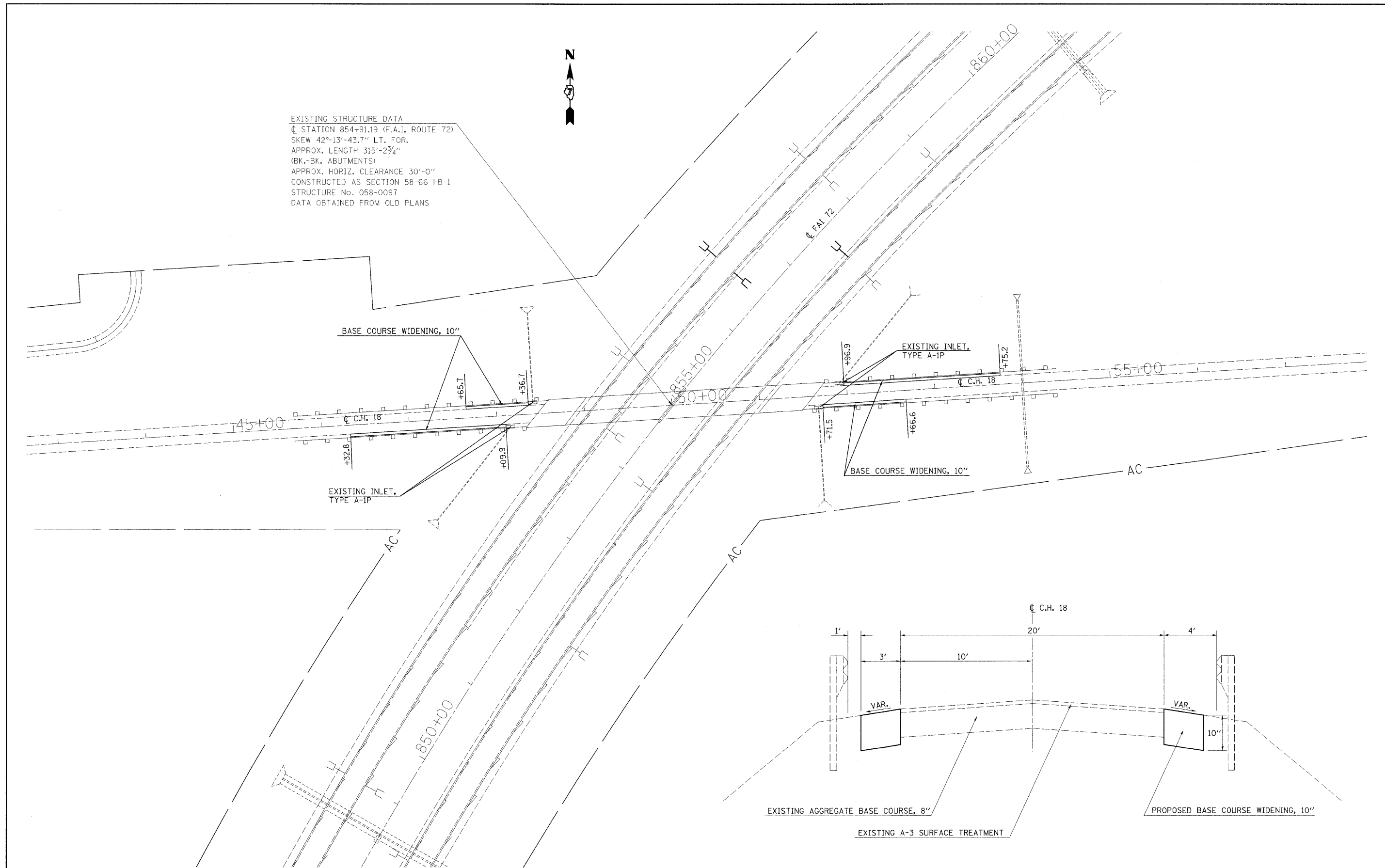

EXISTING STRUCTURE DATA
 C STATION 854+91.19 (F.A.I. ROUTE 72)
 SKEW 42°-13'-43.7" LT. FOR.
 APPROX. LENGTH 315'-2 3/4"
 (BK.-BK. ABUTMENTS)
 APPROX. HORIZ. CLEARANCE 30'-0"
 CONSTRUCTED AS SECTION 58-66 HB-1
 STRUCTURE No. 058-0097
 DATA OBTAINED FROM OLD PLANS



FILE NAME =	USER NAME = swartzrw	DESIGNED -	REVISED -	STATE OF ILLINOIS DEPARTMENT OF TRANSPORTATION	C.H. 18 PLAN SHEET			F.A.I. RTE.	SECTION	COUNTY	TOTAL SHEETS	SHEET NO.
c:\pwork\pwork\SWARTZRW\dms37771\vol	shiplan_74343.dgn	DRAWN -	REVISED -					72	66(B,HVB,HB-1)BR	MACON	83	12
	PLOT SCALE = 50,000' / IN.	CHECKED -	REVISED -		SCALE: 50			SHEET NO. 3 OF 3 SHEETS			STA. 43+00 TO STA. 57+00	
	PLOT DATE = 9/28/2009	DATE -	REVISED -		CONTRACT NO. 74343							
								FED. ROAD DIST. NO. ILLINOIS FED. AID PROJECT				

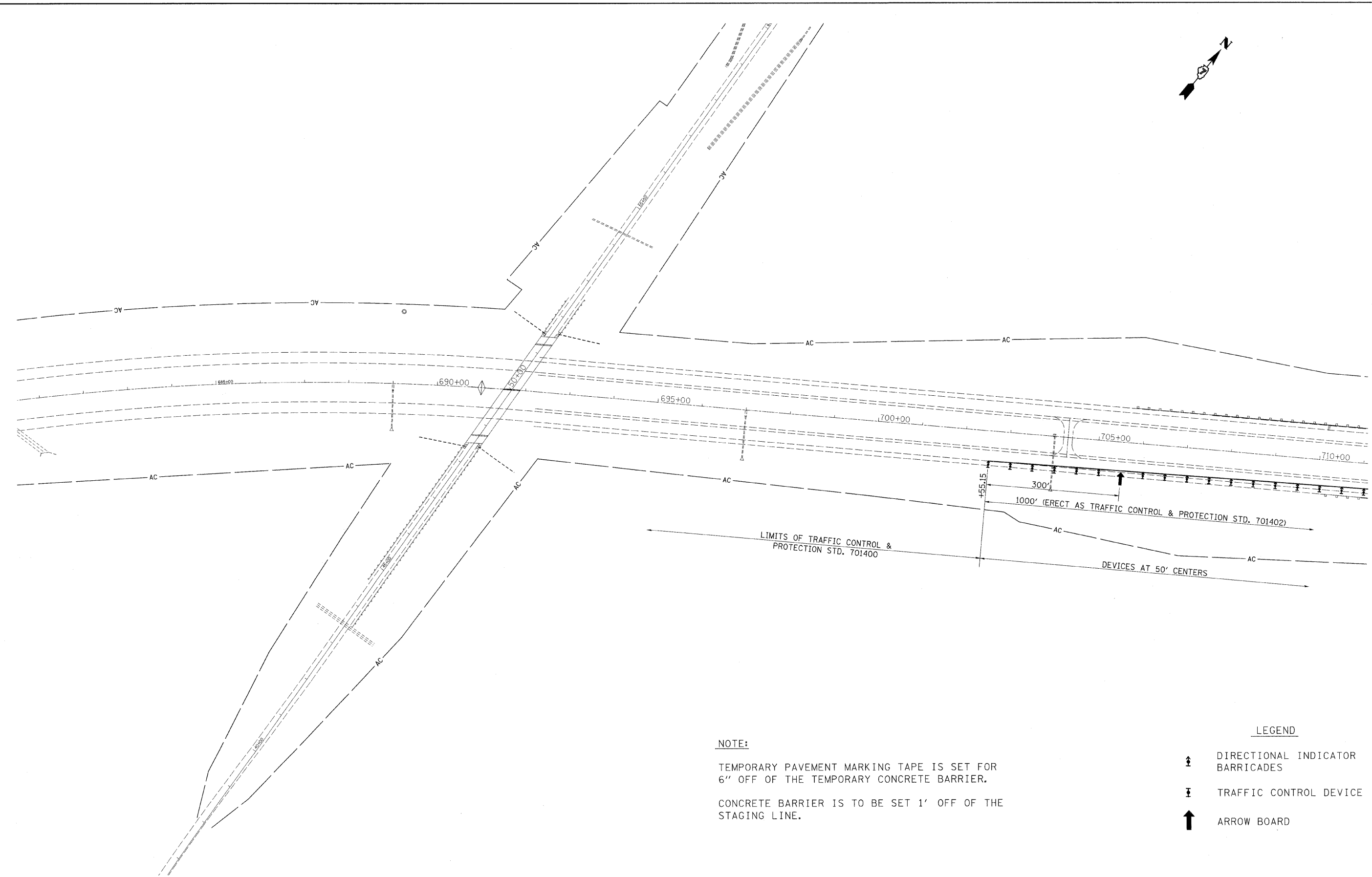
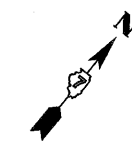

NOTE:

TEMPORARY PAVEMENT MARKING TAPE IS SET FOR 6" OFF OF THE TEMPORARY CONCRETE BARRIER.

CONCRETE BARRIER IS TO BE SET 1' OFF OF THE STAGING LINE.

LEGEND

- DIRECTIONAL INDICATOR BARRICADES
- TRAFFIC CONTROL DEVICE
- ARROW BOARD

FILE NAME = c:\pw\work\PW\DOT\SWARTZRW\dms37771\07	USER NAME = swartzrw	DESIGNED -	REVISED -	STATE OF ILLINOIS DEPARTMENT OF TRANSPORTATION	TRAFFIC CONTROL & PROTECTION, STD 701402 (SPL) STAGE I TRAFFIC CONTROL			F.A.I. RTE. 72	SECTION 66(B,HVB,HB-1)BR	COUNTY MACON	TOTAL SHEETS 83	SHEET NO. 13
	4343-aht-staging.dgn	DRAWN -	REVISED -		SCALE: 100	SHEET NO. 1 OF 6 SHEETS	STA. 681+00 TO STA. 711+00	ILLINOIS FED. AID PROJECT				
	PLOT SCALE = 100.0000 "/ IN.	CHECKED -	REVISED -									
	PLOT DATE = 9/28/2009	DATE -	REVISED -		CONTRACT NO. 74343							

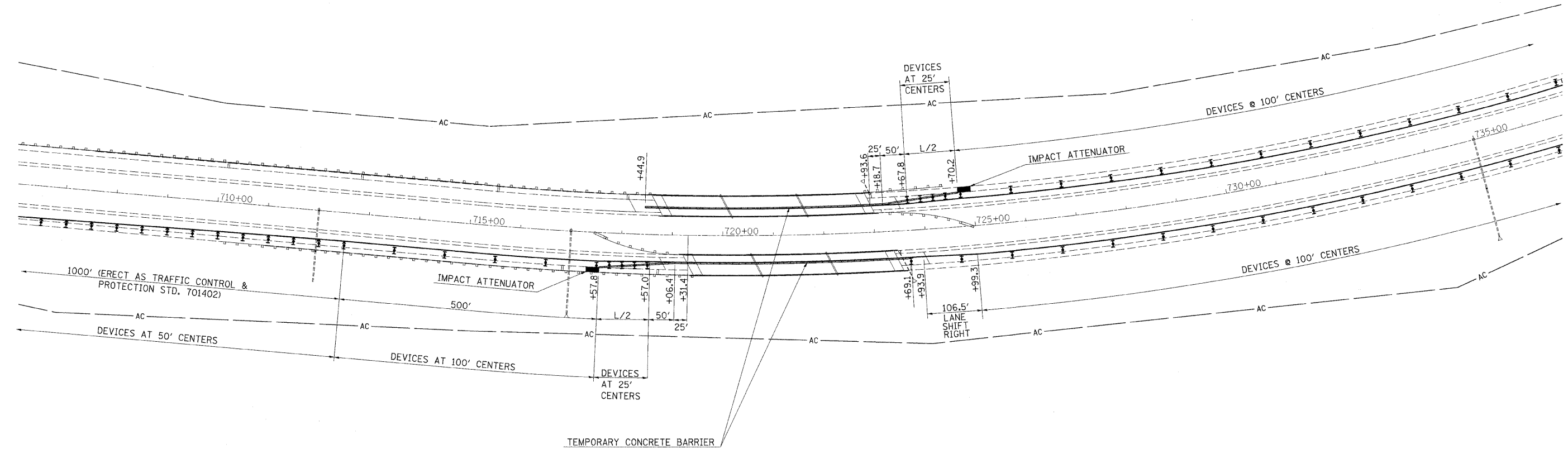
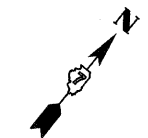



NOTE:

TEMPORARY PAVEMENT MARKING TAPE IS SET FOR 6" OFF OF THE TEMPORARY CONCRETE BARRIER.

CONCRETE BARRIER IS TO BE SET 1' OFF OF THE STAGING LINE.

LEGEND

-  DIRECTIONAL INDICATOR BARRICADES
-  TRAFFIC CONTROL DEVICE
-  ARROW BOARD

FILE NAME = c:\pw\work\PWIDOT\SWARTZRW\dms37771\07	USER NAME = swartzrw 4343-shr-staging.dgn	DESIGNED - DRAWN -	REVISED - REVISED -	STATE OF ILLINOIS DEPARTMENT OF TRANSPORTATION	TRAFFIC CONTROL & PROTECTION, STD 701402 (SPL) STAGE I TRAFFIC CONTROL		F.A.I. RTE. 72	SECTION 66(B,HVB,HB-1)BR	COUNTY MACON	TOTAL SHEETS 83	SHEET NO. 14	
PLOT SCALE = 100.0000' / IN.		CHECKED -	REVISED -		SCALE: 100	SHEET NO. 2 OF 6 SHEETS	STA. 707+00	TO STA. 736+00	ILLINOIS FED. AID PROJECT CONTRACT NO. 74343			
PLOT DATE = 9/28/2009		DATE -	REVISED -									

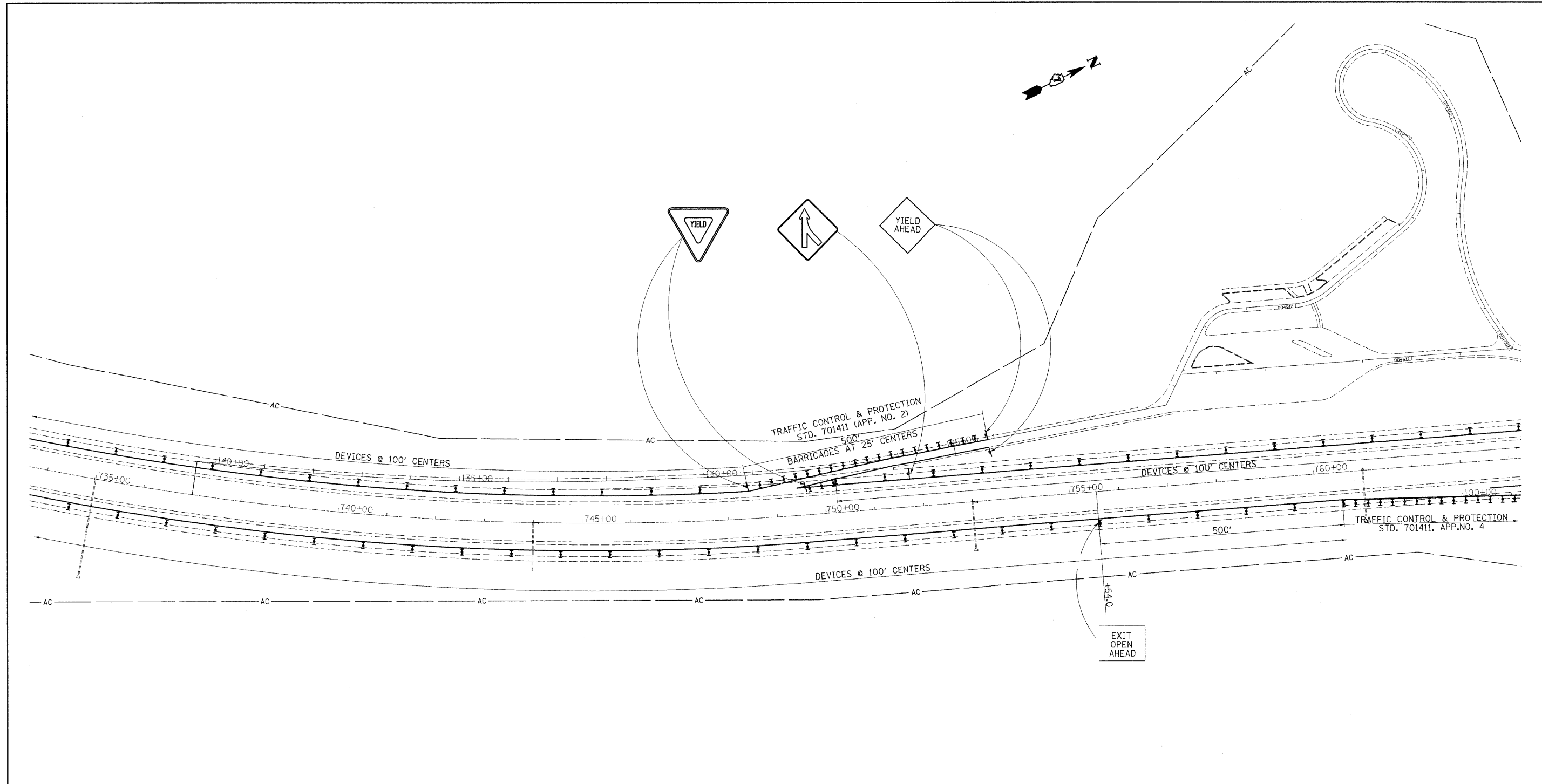



NOTE:

TEMPORARY PAVEMENT MARKING TAPE IS SET FOR 6" OFF OF THE TEMPORARY CONCRETE BARRIER.

CONCRETE BARRIER IS TO BE SET 1' OFF OF THE STAGING LINE.

LEGEND

-  DIRECTIONAL INDICATOR BARRICADES
-  TRAFFIC CONTROL DEVICE
-  ARROW BOARD

FILE NAME =	USER NAME = swartzw	DESIGNED -	REVISED -
c:\pw\work\PWIDOT\SWARTZRW\dms3777\107	4343-sht-staging.dgn	DRAWN -	REVISED -
	PLOT SCALE = 100.0000' / IN.	CHECKED -	REVISED -
	PLOT DATE = 9/28/2009	DATE -	REVISED -

**STATE OF ILLINOIS
DEPARTMENT OF TRANSPORTATION**

**TRAFFIC CONTROL & PROTECTION, STD 701402 (SPL)
STAGE I TRAFFIC CONTROL**

SCALE: 100 SHEET NO. 3 OF 6 SHEETS STA. 734+00 TO STA. 764+00

F.A.I. RTE.	SECTION	COUNTY	TOTAL SHEETS	SHEET NO.
72	66(B,HVB,HB-1)BR	MACON	83	15
CONTRACT NO. 74343				
ILLINOIS FED. AID PROJECT				

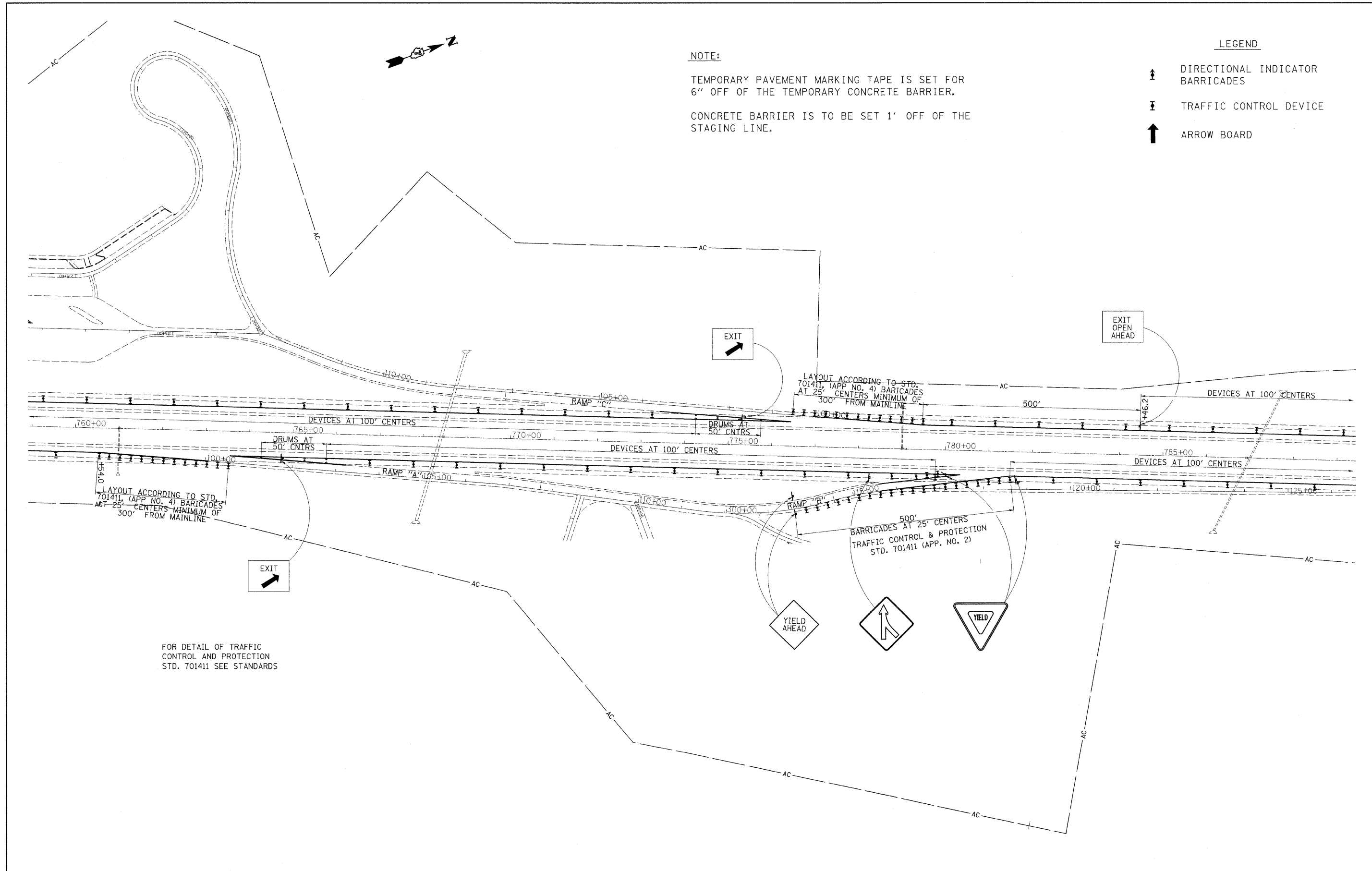

NOTE:

TEMPORARY PAVEMENT MARKING TAPE IS SET FOR 6" OFF OF THE TEMPORARY CONCRETE BARRIER.
 CONCRETE BARRIER IS TO BE SET 1' OFF OF THE STAGING LINE.

LEGEND

- ↑ DIRECTIONAL INDICATOR BARRICADES
- ⌄ TRAFFIC CONTROL DEVICE
- ↑ ARROW BOARD

LAYOUT ACCORDING TO STD. 701411, (APP. NO. 4) BARRICADES AT 25' CENTERS MINIMUM OF 300' FROM MAINLINE

LAYOUT ACCORDING TO STD. 701411, (APP. NO. 4) BARRICADES AT 25' CENTERS MINIMUM OF 300' FROM MAINLINE

FOR DETAIL OF TRAFFIC CONTROL AND PROTECTION STD. 701411 SEE STANDARDS

FILE NAME = c:\pw\work\PWIDOT\SWARTZRW\dms37771\07	USER NAME = swartzrw 4343-sht-staging.dgn	DESIGNED - DRAWN -	REVISED - REVISED -	STATE OF ILLINOIS DEPARTMENT OF TRANSPORTATION	TRAFFIC CONTROL & PROTECTION, STD 701402 (SPL) STAGE I TRAFFIC CONTROL			F.A.I. RTE. 72	SECTION 66(B,HVB,HB-1)BR	COUNTY MACON	TOTAL SHEETS 83	SHEET NO. 16
PLOT SCALE = 100,0000 ' / IN.		CHECKED -	REVISED -		SCALE: 100	SHEET NO. 4 OF 6 SHEETS	STA. 759+00 TO STA. 789+00	CONTRACT NO. 74343				
PLOT DATE = 9/28/2009		DATE -	REVISED -		ILLINOIS FED. AID PROJECT							

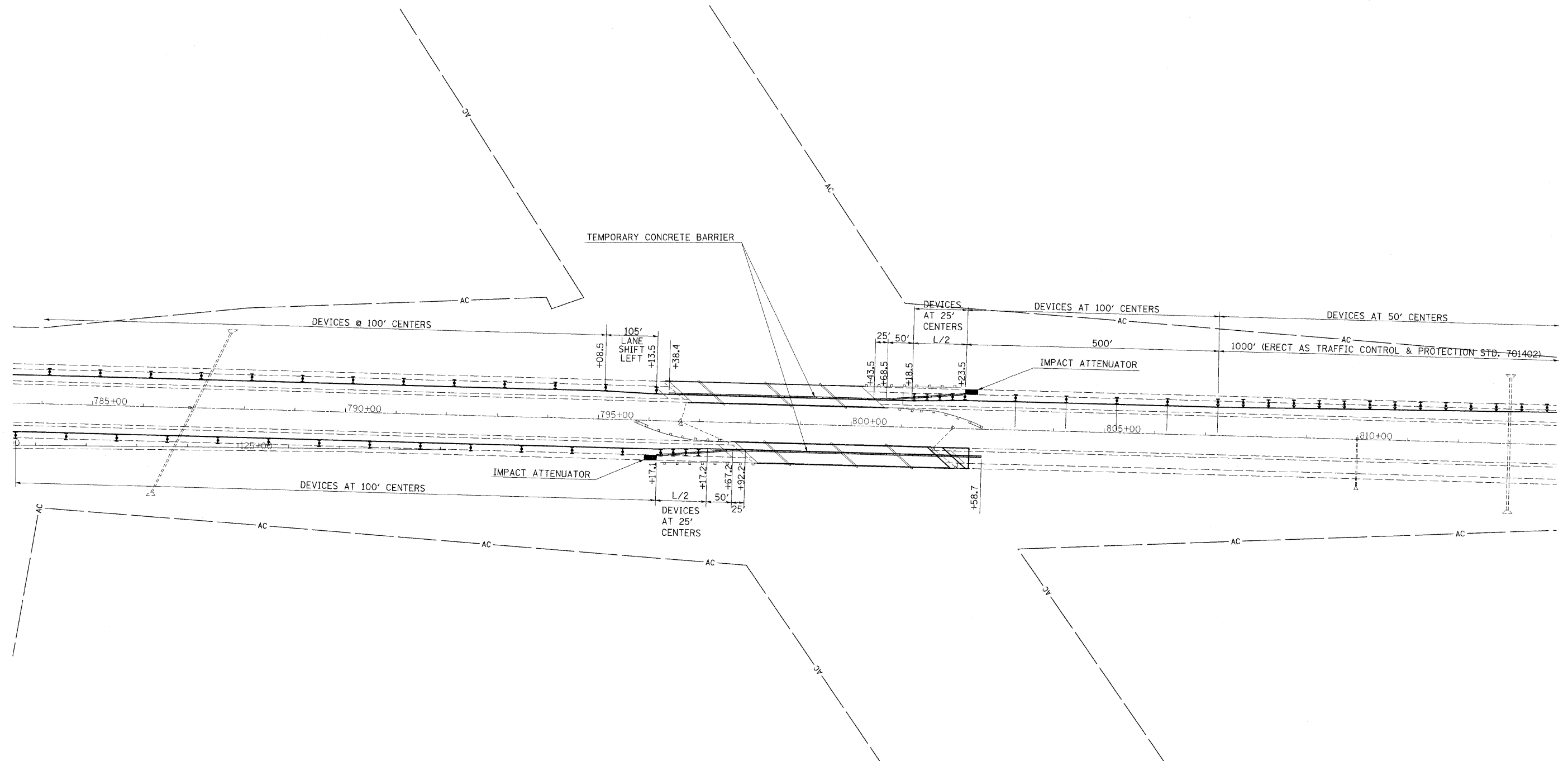

NOTE:

TEMPORARY PAVEMENT MARKING TAPE IS SET FOR 6" OFF OF THE TEMPORARY CONCRETE BARRIER.
 CONCRETE BARRIER IS TO BE SET 1' OFF OF THE STAGING LINE.

LEGEND

- DIRECTIONAL INDICATOR BARRICADES
- TRAFFIC CONTROL DEVICE
- ARROW BOARD

FILE NAME =	USER NAME = swartzrw	DESIGNED -	REVISED -
c:\pw\work\PWIDOT\SWARTZRW\dms37771\07	4343-sht-staging.dgn	DRAWN -	REVISED -
	PLOT SCALE = 100.0000' / IN.	CHECKED -	REVISED -
	PLOT DATE = 9/28/2009	DATE -	REVISED -

**STATE OF ILLINOIS
 DEPARTMENT OF TRANSPORTATION**

**TRAFFIC CONTROL & PROTECTION, STD 701402 (SPL)
 STAGE I TRAFFIC CONTROL**

SCALE: 100 SHEET NO. 5 OF 6 SHEETS STA. 784+00 TO STA. 814+00

F.A.I. RTE.	SECTION	COUNTY	TOTAL SHEETS	SHEET NO.
72	66(B,HVB,HB-1)BR	MACON	83	17
CONTRACT NO. 74343				
ILLINOIS FED. AID PROJECT				

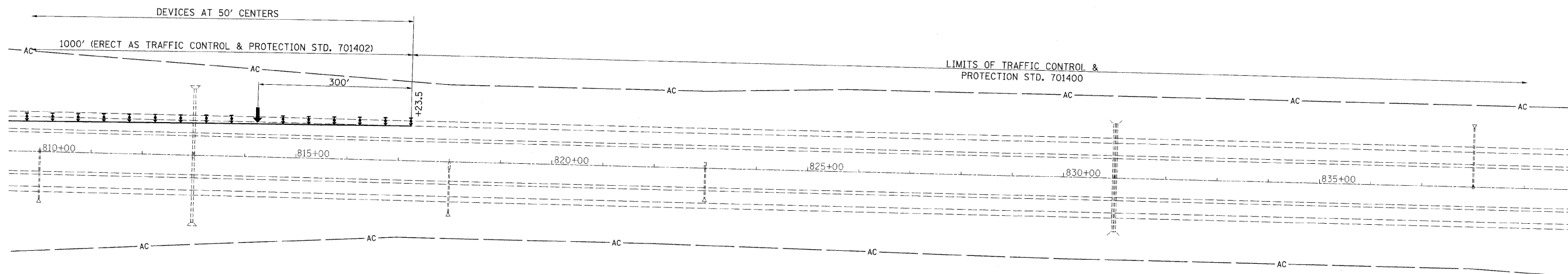



NOTE:

TEMPORARY PAVEMENT MARKING TAPE IS SET FOR 6" OFF OF THE TEMPORARY CONCRETE BARRIER.

CONCRETE BARRIER IS TO BE SET 1' OFF OF THE STAGING LINE.

LEGEND

-  DIRECTIONAL INDICATOR BARRICADES
-  TRAFFIC CONTROL DEVICE
-  ARROW BOARD

FILE NAME = c:\pw_work\PWIDOT\SWARTZRW\dms37771\07	USER NAME = swartzrw	DESIGNED -	REVISED -	STATE OF ILLINOIS DEPARTMENT OF TRANSPORTATION	TRAFFIC CONTROL & PROTECTION, STD 701402 (SPL) STAGE I TRAFFIC CONTROL		F.A.I. RTE. 72	SECTION 66(B,HVB,HB-1)BR	COUNTY MACON	TOTAL SHEETS 83	SHEET NO. 18	
	PLOT SCALE = 100.0000' / 1" IN.	DRAWN -	REVISED -		SCALE: 100	SHEET NO. 6 OF 6 SHEETS	STA. 810+00 TO STA. 839+00	ILLINOIS FED. AID PROJECT				
	PLOT DATE = 9/28/2009	CHECKED -	REVISED -		CONTRACT NO. 74343							
		DATE -	REVISED -									

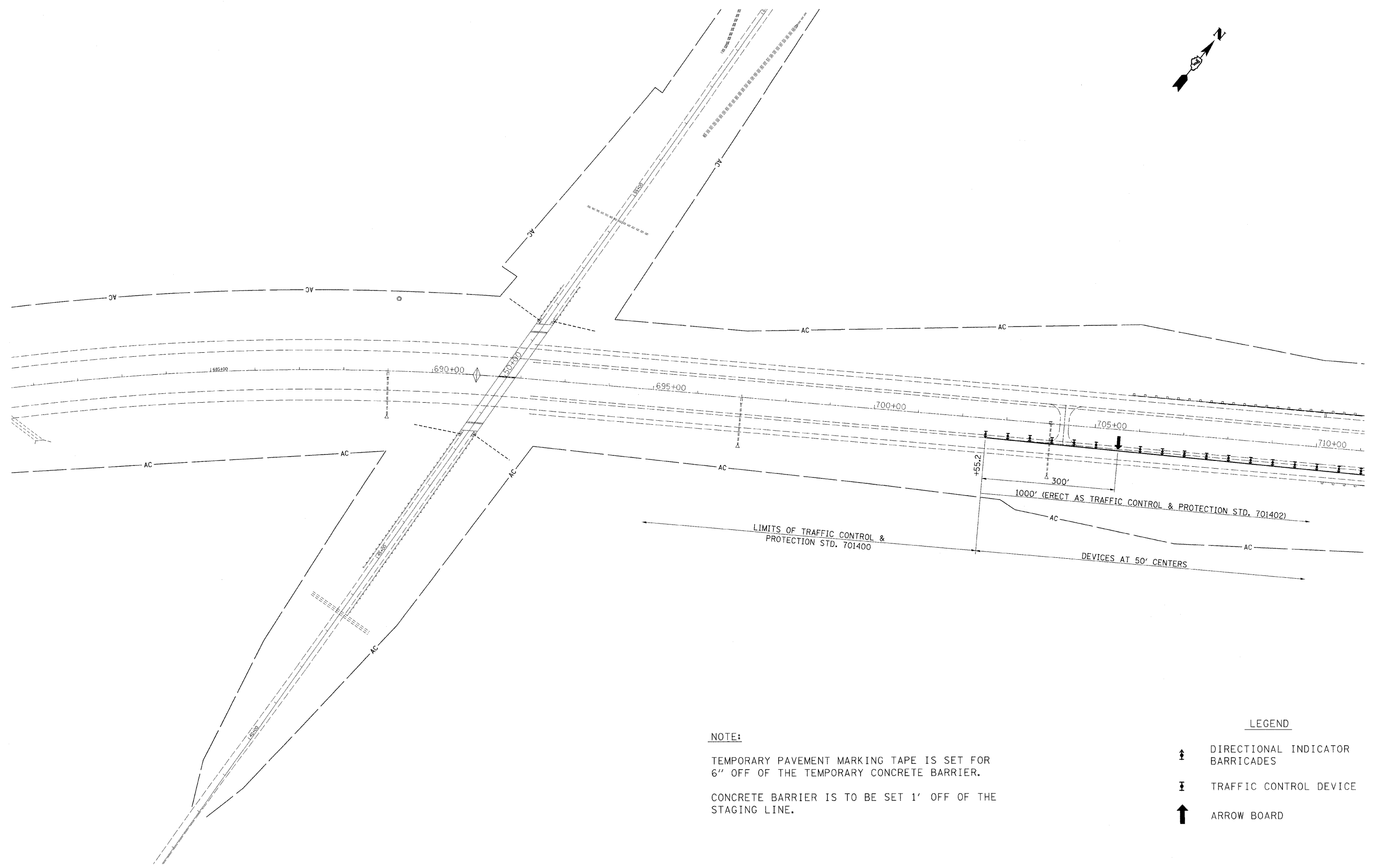
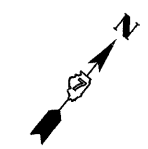

NOTE:

TEMPORARY PAVEMENT MARKING TAPE IS SET FOR 6" OFF OF THE TEMPORARY CONCRETE BARRIER.
 CONCRETE BARRIER IS TO BE SET 1' OFF OF THE STAGING LINE.

LEGEND

- DIRECTIONAL INDICATOR BARRICADES
- TRAFFIC CONTROL DEVICE
- ARROW BOARD

FILE NAME = c:\pw_work\PWIDOT\SWARTZRW\dms37771\07	USER NAME = swartzrw 4343-sht-staging.dgn	DESIGNED - DRAWN -	REVISED - REVISED -	STATE OF ILLINOIS DEPARTMENT OF TRANSPORTATION	TRAFFIC CONTROL & PROTECTION, STD 701402 (SPL) STAGE II TRAFFIC CONTROL			F.A.I. RTE. 72	SECTION 66(B,HVB,HB-1)BR	COUNTY MACON	TOTAL SHEETS 83	SHEET NO. 19
PLOT SCALE = 100.0000 ' / IN.		CHECKED -	REVISED -		SCALE: 100	SHEET NO. 1 OF 6 SHEETS	STA. 681+00	TO STA. 711+00	ILLINOIS FED. AID PROJECT			
PLOT DATE = 9/28/2009		DATE -	REVISED -		CONTRACT NO. 74343							

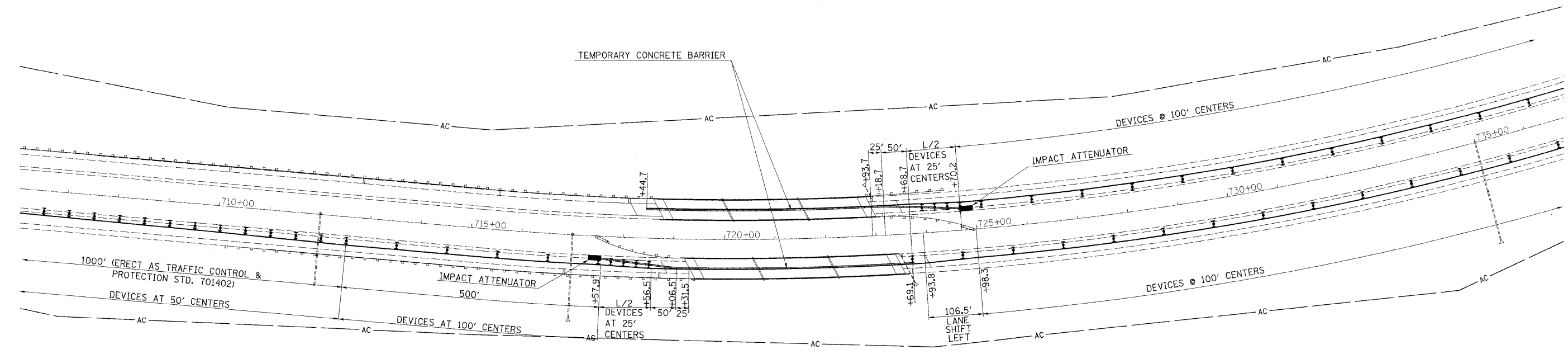
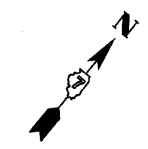

NOTE:

TEMPORARY PAVEMENT MARKING TAPE IS SET FOR 6" OFF OF THE TEMPORARY CONCRETE BARRIER.

CONCRETE BARRIER IS TO BE SET 1' OFF OF THE STAGING LINE.

LEGEND

- DIRECTIONAL INDICATOR BARRICADES
- TRAFFIC CONTROL DEVICE
- ARROW BOARD

FILE NAME = c:\pw\work\PW1001\SWARTZRW\dms37771\07	USER NAME = swartzrw 4343-aht-staging.dgn	DESIGNED - DRAWN -	REVISED - REVISED -	STATE OF ILLINOIS DEPARTMENT OF TRANSPORTATION	TRAFFIC CONTROL & PROTECTION, STD 701402 (SPL) STAGE II TRAFFIC CONTROL		F.A.I. RTE. 72	SECTION 66(B,HVB,HB-1)BR	COUNTY MACON	TOTAL SHEETS 83	SHEET NO. 20	
PLOT SCALE = 100.0000' / 1" IN.		CHECKED -	REVISED -		SCALE: 100	SHEET NO. 2 OF 6 SHEETS	STA. 707+00 TO STA. 736+00	ILLINOIS FED. AID PROJECT CONTRACT NO. 74343				
PLOT DATE = 9/28/2009		DATE -	REVISED -									

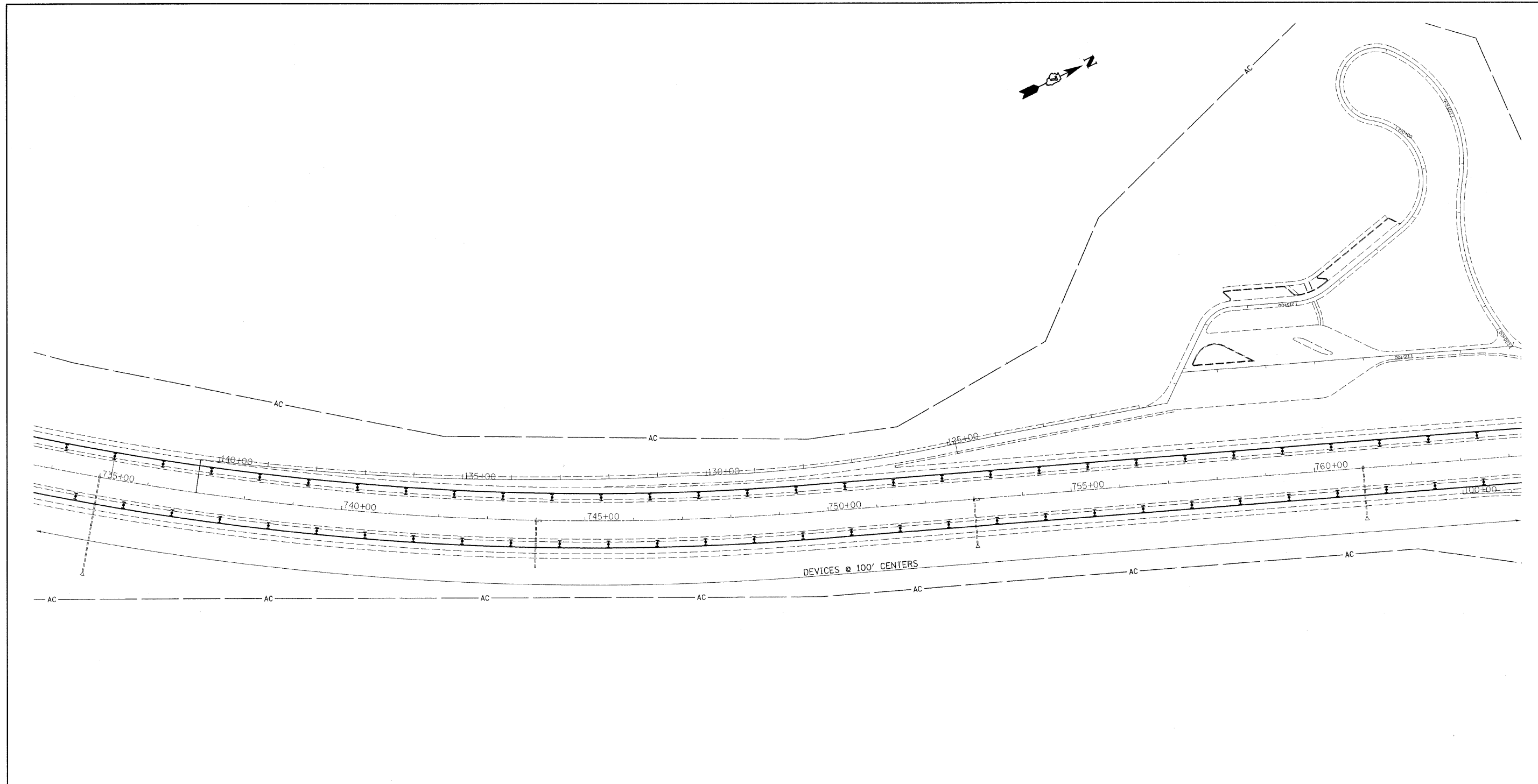



NOTE:

TEMPORARY PAVEMENT MARKING TAPE IS SET FOR 6" OFF OF THE TEMPORARY CONCRETE BARRIER.

CONCRETE BARRIER IS TO BE SET 1' OFF OF THE STAGING LINE.

LEGEND

-  DIRECTIONAL INDICATOR BARRICADES
-  TRAFFIC CONTROL DEVICE
-  ARROW BOARD

FILE NAME =	USER NAME = swartzrw	DESIGNED -	REVISED -
cr\pw\work\PWIDOT\SWARTZRW\dms37771\07	4343-ahb-staging.dgn	DRAWN -	REVISED -
	PLOT SCALE = 100.0000' / IN.	CHECKED -	REVISED -
	PLOT DATE = 9/28/2009	DATE -	REVISED -

**STATE OF ILLINOIS
DEPARTMENT OF TRANSPORTATION**

**TRAFFIC CONTROL & PROTECTION, STD 701402 (SPL)
STAGE II TRAFFIC CONTROL**

SCALE: 100 SHEET NO. 3 OF 6 SHEETS STA. 734+00 TO STA. 764+00

F.A.I. RTE.	SECTION	COUNTY	TOTAL SHEETS	SHEET NO.
72	66IB,HVB,HB-1BR	MACON	83	21
CONTRACT NO. 74343				
ILLINOIS FED. AID PROJECT				

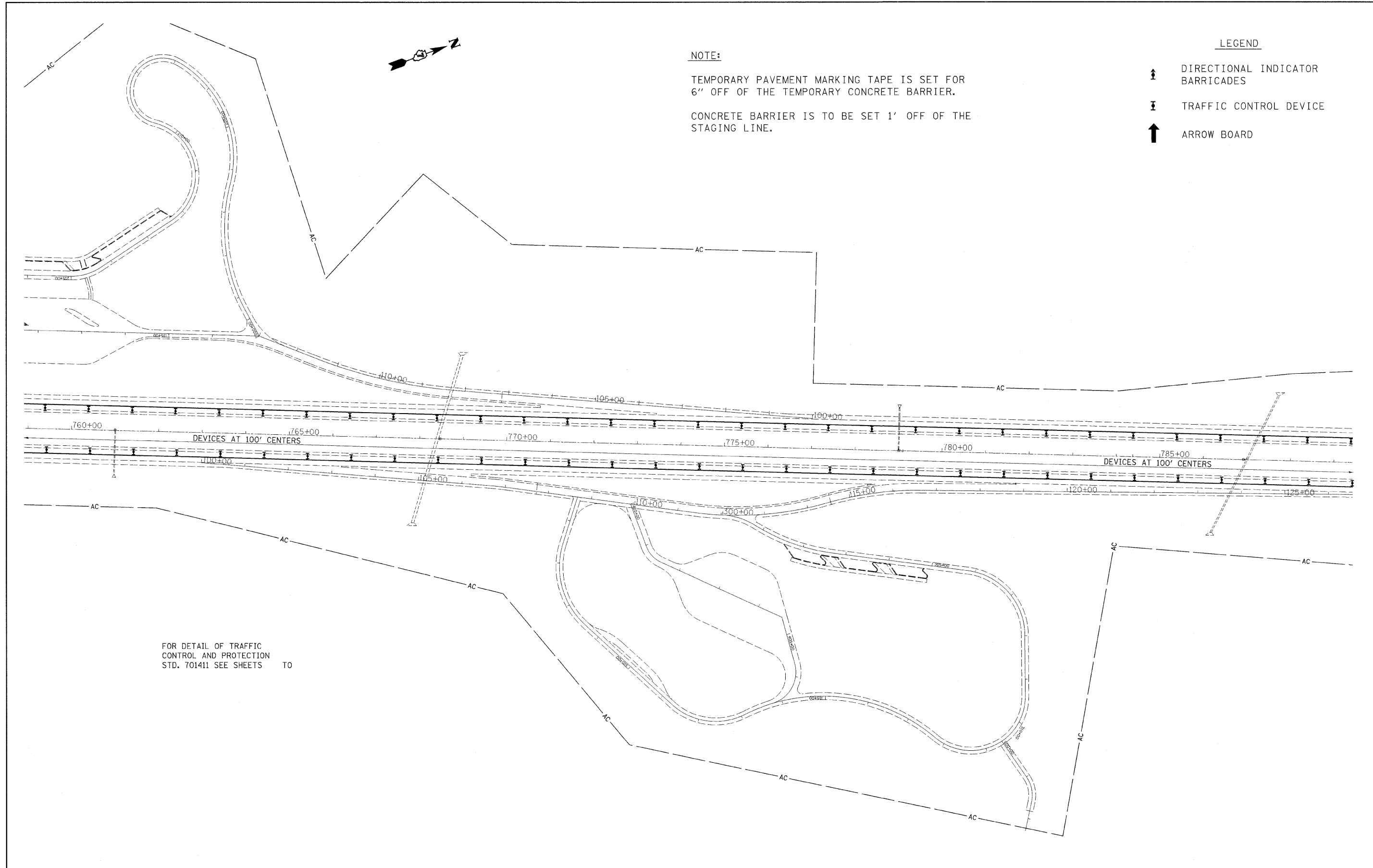

NOTE:
 TEMPORARY PAVEMENT MARKING TAPE IS SET FOR 6" OFF OF THE TEMPORARY CONCRETE BARRIER.
 CONCRETE BARRIER IS TO BE SET 1' OFF OF THE STAGING LINE.

- LEGEND**
- ↑ DIRECTIONAL INDICATOR BARRICADES
 - ⌄ TRAFFIC CONTROL DEVICE
 - ↑ ARROW BOARD

FOR DETAIL OF TRAFFIC CONTROL AND PROTECTION STD. 701411 SEE SHEETS TO

FILE NAME = c:\pwork\PW100T\SWARTZRW\dms37771\07	USER NAME = swartzrw 4343-sht-staging.dgn	DESIGNED - DRAWN -	REVISED - REVISED -	STATE OF ILLINOIS DEPARTMENT OF TRANSPORTATION	TRAFFIC CONTROL & PROTECTION, STD 701402 (SPL) STAGE II TRAFFIC CONTROL		F.A.I. RTE. 72	SECTION 66(B,HVB,HB-1)BR	COUNTY MACON	TOTAL SHEETS 83	SHEET NO. 22	
PLOT SCALE = 100.0000' / IN.	CHECKED -	REVISED -	SCALE: 100		SHEET NO. 4 OF 6 SHEETS	STA. 759+00	TO STA. 789+00	CONTRACT NO. 74343				
PLOT DATE = 9/28/2009	DATE -	REVISED -	ILLINOIS FED. AID PROJECT									

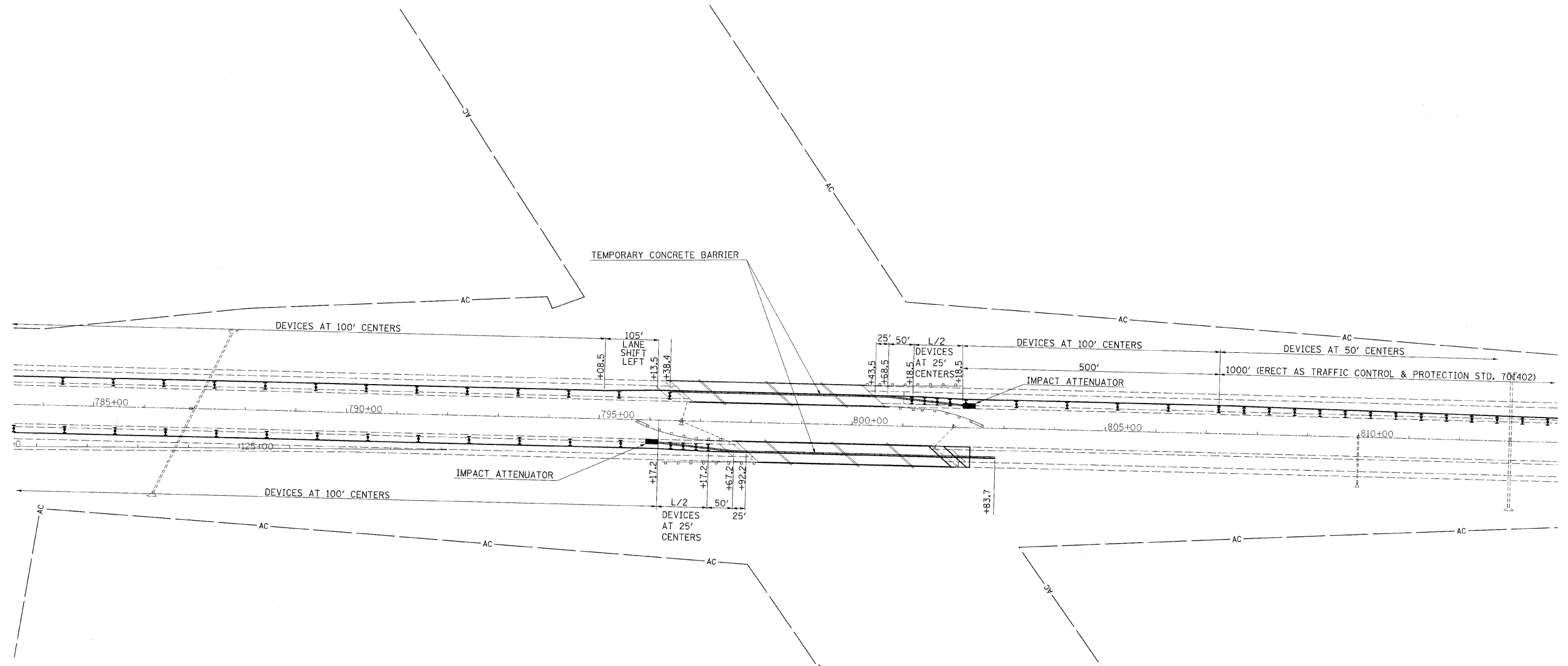



NOTE:

TEMPORARY PAVEMENT MARKING TAPE IS SET FOR 6" OFF OF THE TEMPORARY CONCRETE BARRIER.

CONCRETE BARRIER IS TO BE SET 1' OFF OF THE STAGING LINE.

LEGEND

-  DIRECTIONAL INDICATOR BARRICADES
-  TRAFFIC CONTROL DEVICE
-  ARROW BOARD

FILE NAME = c:\pw_work\PWIDOT\SWARTZRW\dms37771\07	USER NAME = swartzrw 4343-sht-staging.dgn	DESIGNED - DRAWN -	REVISED - REVISED -
	PLOT SCALE = 100.0000' / 1" IN.	CHECKED -	REVISED -
	PLOT DATE = 9/28/2009	DATE -	REVISED -

**STATE OF ILLINOIS
DEPARTMENT OF TRANSPORTATION**

**TRAFFIC CONTROL & PROTECTION, STD 701402 (SPL)
STAGE II TRAFFIC CONTROL**

SCALE: 100 SHEET NO. 5 OF 6 SHEETS STA. 784+00 TO STA. 814+00

F.A.I. RTE. 72	SECTION 66(B),HVB,HB-1BR	COUNTY MACON	TOTAL SHEETS 83	SHEET NO. 23
CONTRACT NO. 74343				
ILLINOIS FED. AID PROJECT				

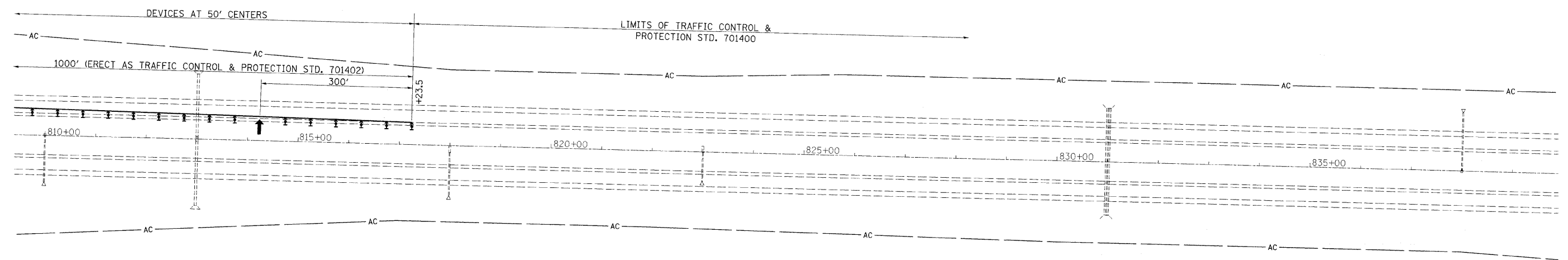

NOTE:

TEMPORARY PAVEMENT MARKING TAPE IS SET FOR 6" OFF OF THE TEMPORARY CONCRETE BARRIER.
 CONCRETE BARRIER IS TO BE SET 1' OFF OF THE STAGING LINE.

LEGEND

- DIRECTIONAL INDICATOR BARRICADES
- TRAFFIC CONTROL DEVICE
- ARROW BOARD

FILE NAME = c:\pwwork\pwwid001\SWARTZRW\dms37771\07	USER NAME = swartzrw	DESIGNED -	REVISED -	STATE OF ILLINOIS DEPARTMENT OF TRANSPORTATION	TRAFFIC CONTROL & PROTECTION, STD 701402 (SPL) STAGE II TRAFFIC CONTROL		F.A.I. RTE. 72	SECTION 66(B,HVB,HB-1)BR	COUNTY MACON	TOTAL SHEETS 83	SHEET NO. 24	
	4343-ahs-staging.dgn	DRAWN -	REVISED -		SCALE: 100	SHEET NO. 6 OF 6 SHEETS	STA. 810+00 TO STA. 839+00	ILLINOIS FED. AID PROJECT				
	PLOT SCALE = 1000.0000' / 1" IN.	CHECKED -	REVISED -					CONTRACT NO. 74343				
	PLOT DATE = 9/28/2009	DATE -	REVISED -									

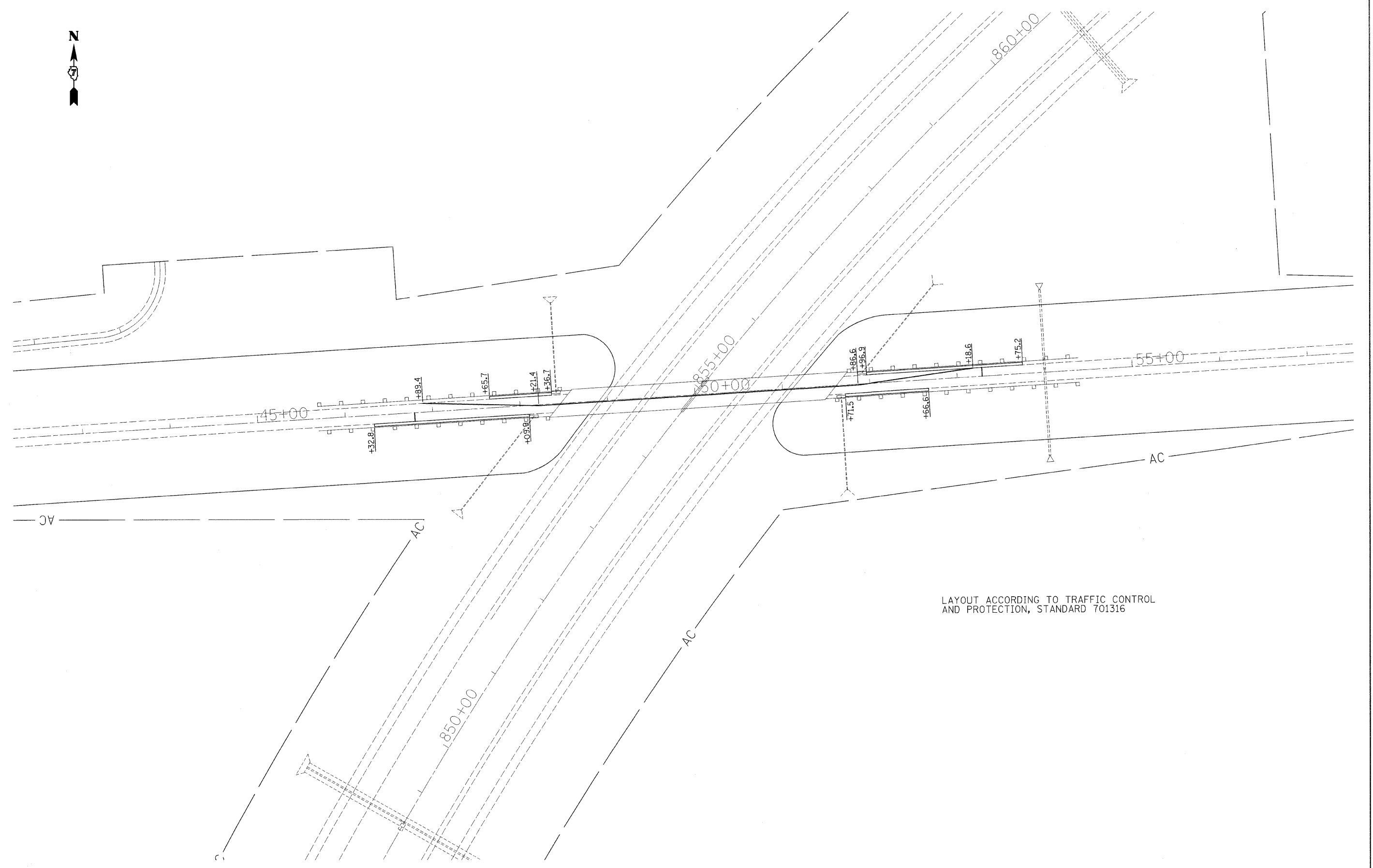

FILE NAME = c:\pw_work\FWIDOT\SWARTZRW\dms37771\D7	USER NAME = swartzrw	DESIGNED -	REVISED -	STATE OF ILLINOIS DEPARTMENT OF TRANSPORTATION	STAGE I - C.H. 18		F.A.I. RTE. 72	SECTION 66(B,HVB,HB-1)BR	COUNTY MACON	TOTAL SHEETS 83	SHEET NO. 25
	PLOT SCALE = 50.0000' / IN.	DRAWN -	REVISED -		SCALE: 50	SHEET NO. 1 OF 1 SHEETS	STA. TO STA.	CONTRACT NO. 74343			
PLOT DATE = 9/28/2009	CHECKED -	REVISED -			ILLINOIS FED. AID PROJECT						
	DATE -	REVISED -									

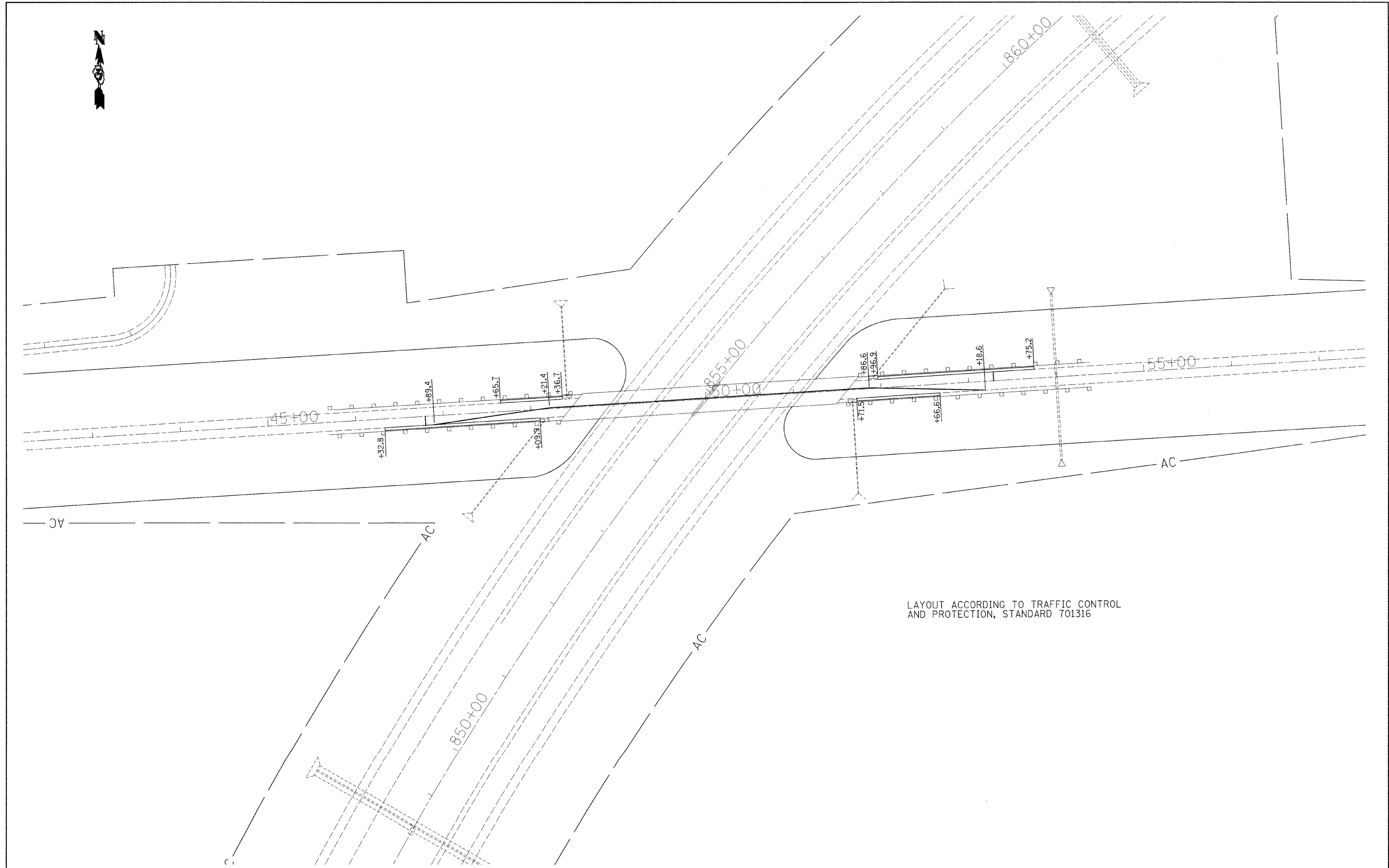

FILE NAME =	USER NAME = swartzrw	DESIGNED -	REVISED -
c:\pwork\PWIDOT\SWARTZRW\dms37771\07	4343-sht-staging.dgn	DRAWN -	REVISED -
	PLOT SCALE = 50.0000' / IN.	CHECKED -	REVISED -
	PLOT DATE = 9/28/2009	DATE -	REVISED -

**STATE OF ILLINOIS
DEPARTMENT OF TRANSPORTATION**

STAGE II - C.H. 18

SCALE: 50 SHEET NO. 1 OF 1 SHEETS STA. TO STA.

F.A.I. RTE.	SECTION	COUNTY	TOTAL SHEETS	SHEET NO.
72	66(B),HVB,HB-1JBR	MACON	83	26
ILLINOIS FED. AID PROJECT				
CONTRACT NO. 74343				

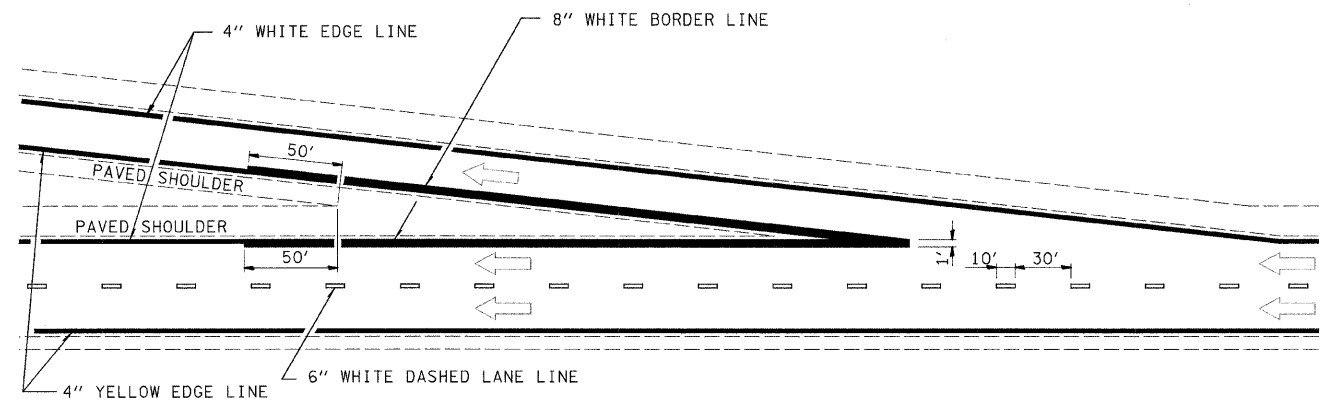

TYPICAL EXIT RAMP MARKING

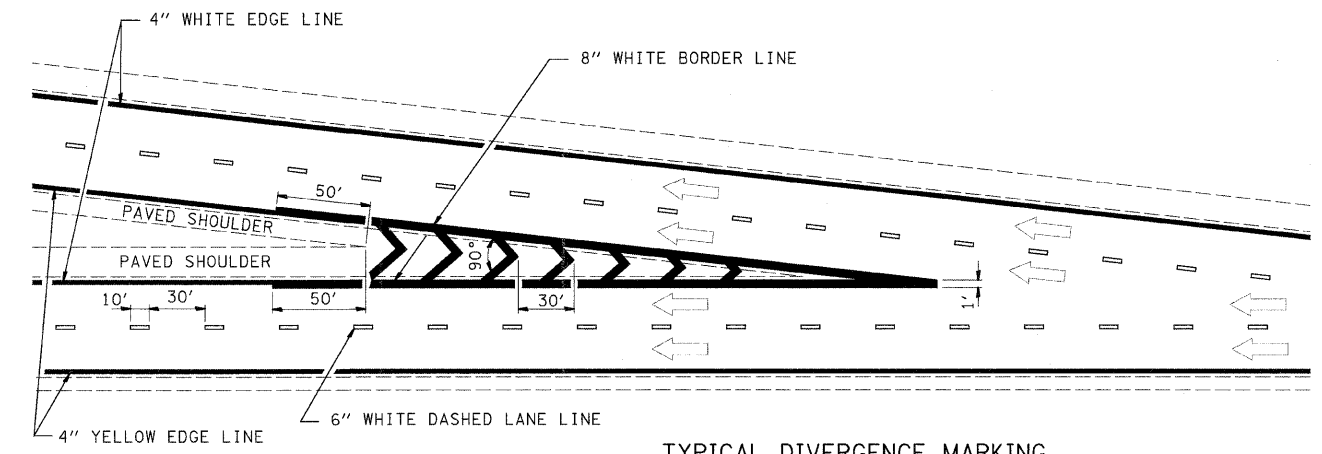

TYPICAL DIVERGENCE MARKING

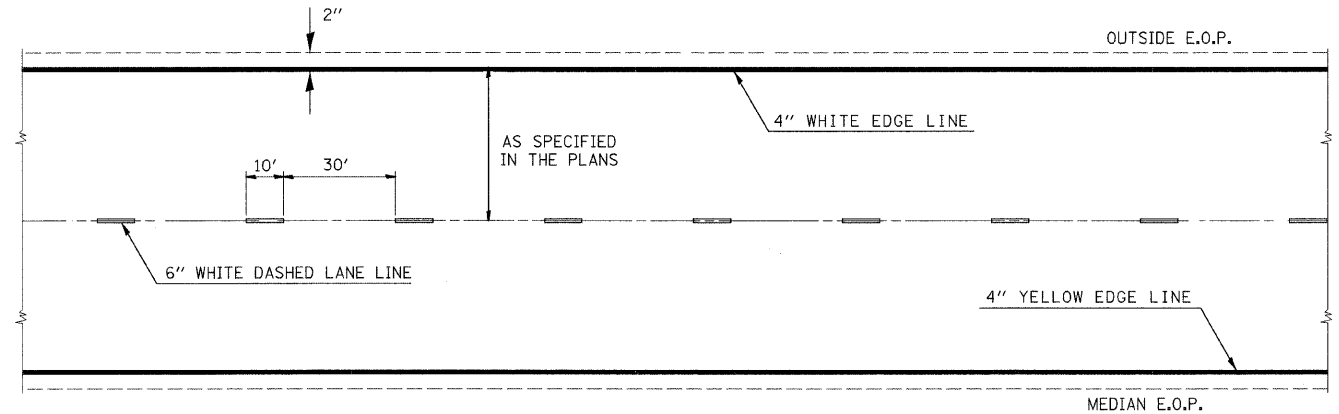

TYPICAL CENTERLINE & EDGELINE MARKINGS

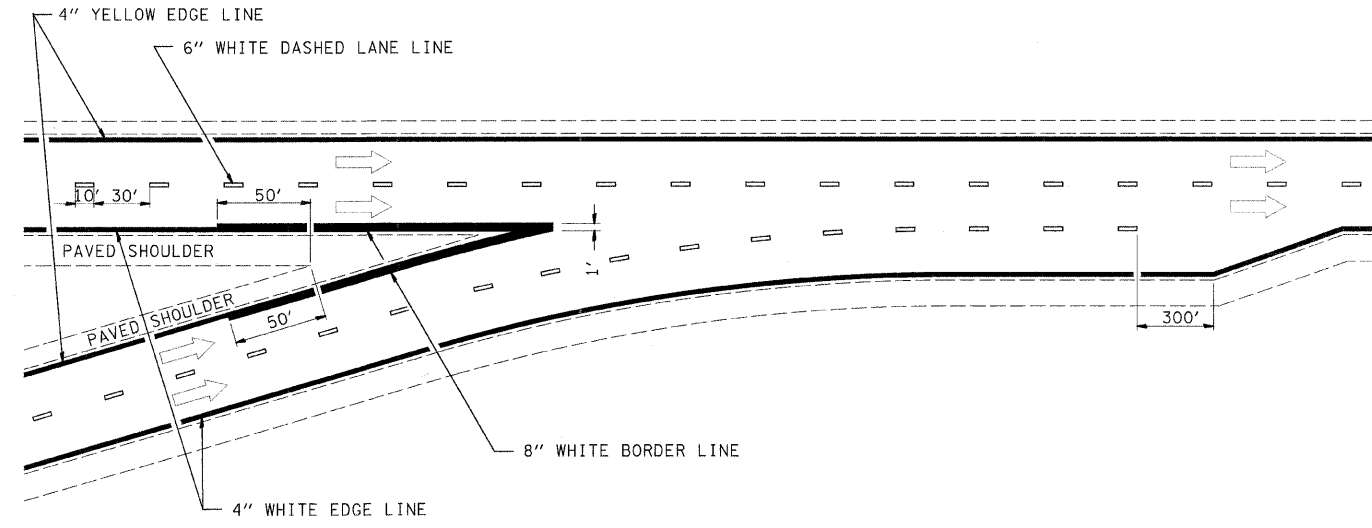

TYPICAL CONVERGENCE MARKING

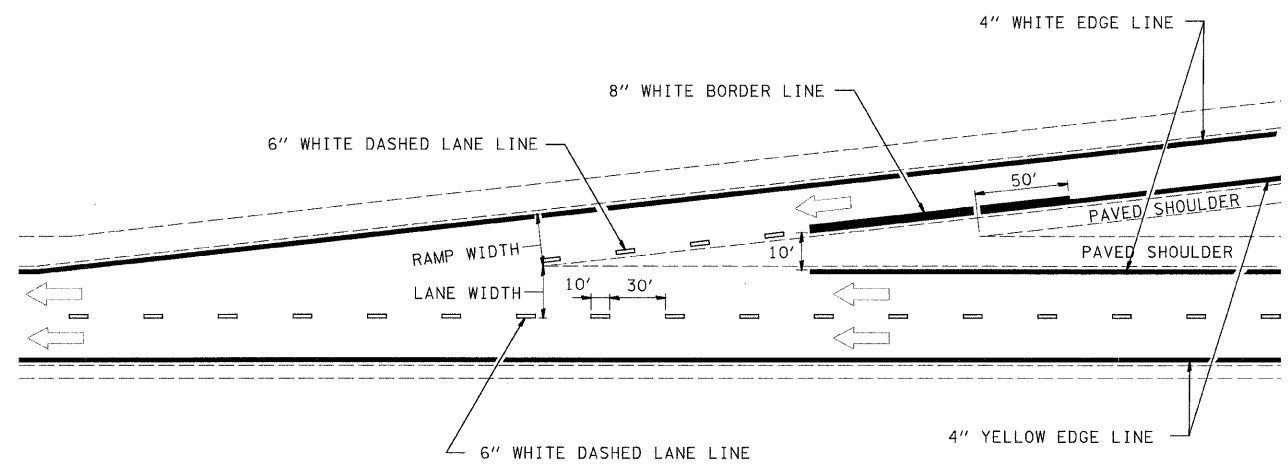

TYPICAL ENTRANCE RAMP MARKING

TYPICAL APPLICATIONS OF INTERCHANGE PAVEMENT MARKING
NOT TO SCALE

REVISIONS	
NAME	DATE
MMO	12-99
DRM	08-04

FILE NAME =	USER NAME = swartzw	DESIGNED -	REVISED -
c:\pw\work\PW\IDOT\SWARTZRW\dms27771\veh	details_74343.dgn	DRAWN -	REVISED -
	PLOT SCALE = 20,00000' / IN.	CHECKED -	REVISED -
	PLOT DATE = 9/28/2009	DATE -	REVISED -

STATE OF ILLINOIS
DEPARTMENT OF TRANSPORTATION

DETAILS

SCALE: NA SHEET NO. 1 OF 1 SHEETS STA. TO STA.

F.A.I. RTE.	SECTION	COUNTY	TOTAL SHEETS	SHEET NO.
72	66(B,HVB,HB-1)BR	MACON	83	27
CONTRACT NO. 74343				
FED. ROAD DIST. NO. ILLINOIS FED. AID PROJECT				

GENERAL NOTES

Reinforcement bars shall conform to the requirements of ASTM A 706 Br 60 (IL Modified). See Special Provisions.

Reinforcement bars designated (E) shall be epoxy coated.

Plan dimensions and details relative to existing plans are subject to routine variations. The Contractor shall field verify existing dimensions and details affecting new construction and make necessary approved adjustments prior to construction or ordering of materials. Such variations shall not be cause for additional compensations for a change in scope of the work; however, the Contractor will be paid for the quantity actually furnished based upon the unit price bid for the work.

Existing reinforcement bars extending into the removal area shall be cleaned, straightened and incorporated into the new construction. Any reinforcement bars that are damaged during concrete removal operations shall be repaired or replaced using an approved bar splicer or anchorage system. Cost included in concrete removal.

Joint openings shall be adjusted according to Article 520.04 of the Standard Specifications when the deck is poured at an ambient temperature other than 50°F.

Prior to pouring the new concrete deck, all heavy or loose rust, loose mill scale, and other loose or potentially detrimental foreign material shall be removed from the surfaces in contact with concrete. Tightly adhered paint may remain unless otherwise noted. Removal shall be accomplished by methods that will not damage the steel and the cost will be included in the pay item covering removal of the existing concrete.

Removal and replacement of the end handrail sections and support posts at both abutments of both structures will be necessary for construction of the expansion joints. The existing handrail sections and support posts shall be reused. New bolts, shim plates, and post support anchor assemblies as detailed in the plans are to be provided and installed for the replacement of the handrail and supports. This work and all materials shall be included in the contract unit price for concrete superstructure.

Areas of deck repairs shown are estimated. The Engineer shall show actual locations of deck repairs on as-built plans.

The existing waterproofing membrane system is not known to contain asbestos.

Construction of a Bridge Approach Wingwall Improvement at locations specified on the plans will be necessary prior to erecting the new guardrail. The end of the existing aluminum railing shall be cut as shown in the details and removed prior to placement of the new concrete. This work and all materials shall be included in the contract unit price for concrete superstructure.

TOTAL BILL OF MATERIALS

SN 058-0093 (EB)

ITEM DESCRIPTION	UNIT	QUANTITY
Concrete Removal	Cu. Yd.	11.6
Concrete Superstructure	Cu. Yd.	13.8
Reinforcement Bars, Epoxy Coated	Pound	3490
Bar Splicers	Each	28
Elastomeric Bearing Assembly Type I	Each	6
Elastomeric Bearing Assembly Type II	Each	6
Furnishing and Erecting Structural Steel	Pound	2355
Jack and Remove Existing Bearings	Each	12
Hot-Mix Asphalt Removal (Deck)	Sq. Yd.	1740
Bridge Deck Hydro-Scarification, 1/2"	Sq. Yd.	1740
Bridge Deck Microsilica Concrete Overlay, 2 1/4"	Sq. Yd.	1740
Bridge Deck Grooving	Sq. Yd.	1740
Protective Coat	Sq. Yd.	1740
Deck Slab Repair (Full Depth Type I)	Sq. Yd.	7
Deck Slab Repair (Full Depth Type II)	Sq. Yd.	10
Floor Drains	Each	30
Preformed Joint Strip Seal	Foot	96
Structural Repair of Concrete <5"	Sq. Ft.	121
Plug Existing Deck Drains	Each	33
Anchor Bolts 1" Ø	Each	24

TOTAL BILL OF MATERIALS

SN 058-0094 (WB)

ITEM DESCRIPTION	UNIT	QUANTITY
Concrete Removal	Cu. Yd.	11.6
Concrete Superstructure	Cu. Yd.	14.1
Reinforcement Bars, Epoxy Coated	Pound	3530
Bar Splicers	Each	28
Elastomeric Bearing Assembly Type I	Each	6
Elastomeric Bearing Assembly Type II	Each	6
Furnishing and Erecting Structural Steel	Pound	2355
Jack and Remove Existing Bearings	Each	12
Hot-Mix Asphalt Removal (Deck)	Sq. Yd.	1749
Bridge Deck Hydro-Scarification, 1/2"	Sq. Yd.	1749
Bridge Deck Microsilica Concrete Overlay, 2 1/4"	Sq. Yd.	1749
Bridge Deck Grooving	Sq. Yd.	1749
Protective Coat	Sq. Yd.	1749
Deck Slab Repair (Full Depth Type I)	Sq. Yd.	7
Deck Slab Repair (Full Depth Type II)	Sq. Yd.	18
Floor Drains	Each	30
Preformed Joint Strip Seal	Foot	96
Structural Repair of Concrete <5"	Sq. Ft.	167
Plug Existing Deck Drains	Each	33
Anchor Bolts 1" Ø	Each	24

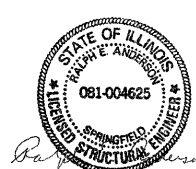

Expires Nov. 30, 2010

FILE NAME =	USER NAME = swartzrw	DESIGNED -	REVISED -	STATE OF ILLINOIS DEPARTMENT OF TRANSPORTATION	BRIDGE GENERAL NOTES & BILL OF MATERIALS SN. 058-0093 (EB) & 058-0094 (WB)	F.A.I. RTE.	SECTION	COUNTY	TOTAL SHEETS	SHEET NO.	
c:\pwork\pwwd01\SWARTZRW\dms37779\k	enbridge.dgn	DRAWN -	REVISED -			72	66(B,HVB,HB-1)BR	MACON	83	28	
	PLOT SCALE = 20,0000' / IN.	CHECKED -	REVISED -			CONTRACT NO. 74343					
	PLOT DATE = 9/28/2009	DATE -	REVISED -			SCALE: N/A	SHEET NO. 1 OF 17 SHEETS	STA.	TO STA.	FED. ROAD DIST. NO. ILLINOIS FED. AID PROJECT	

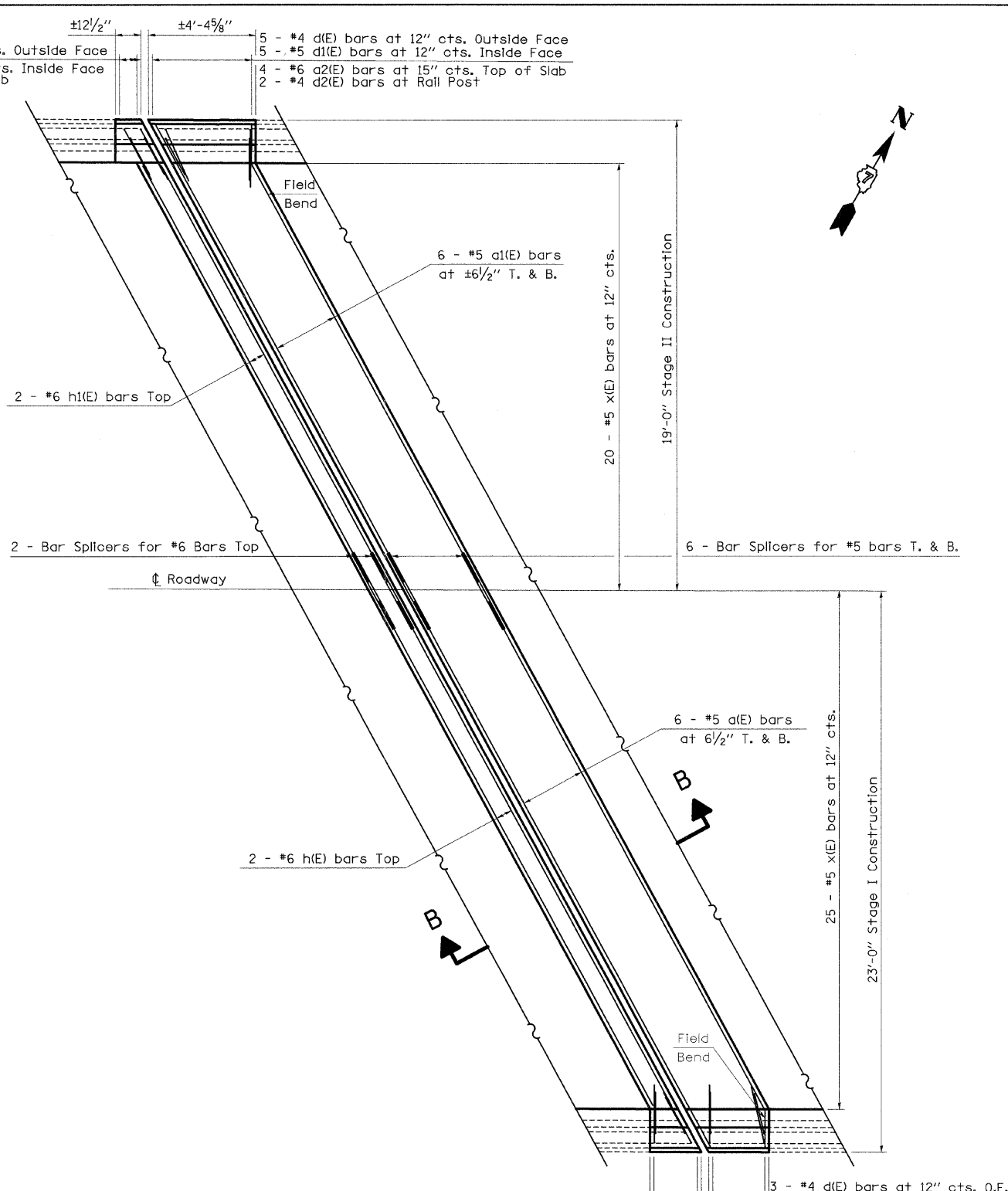
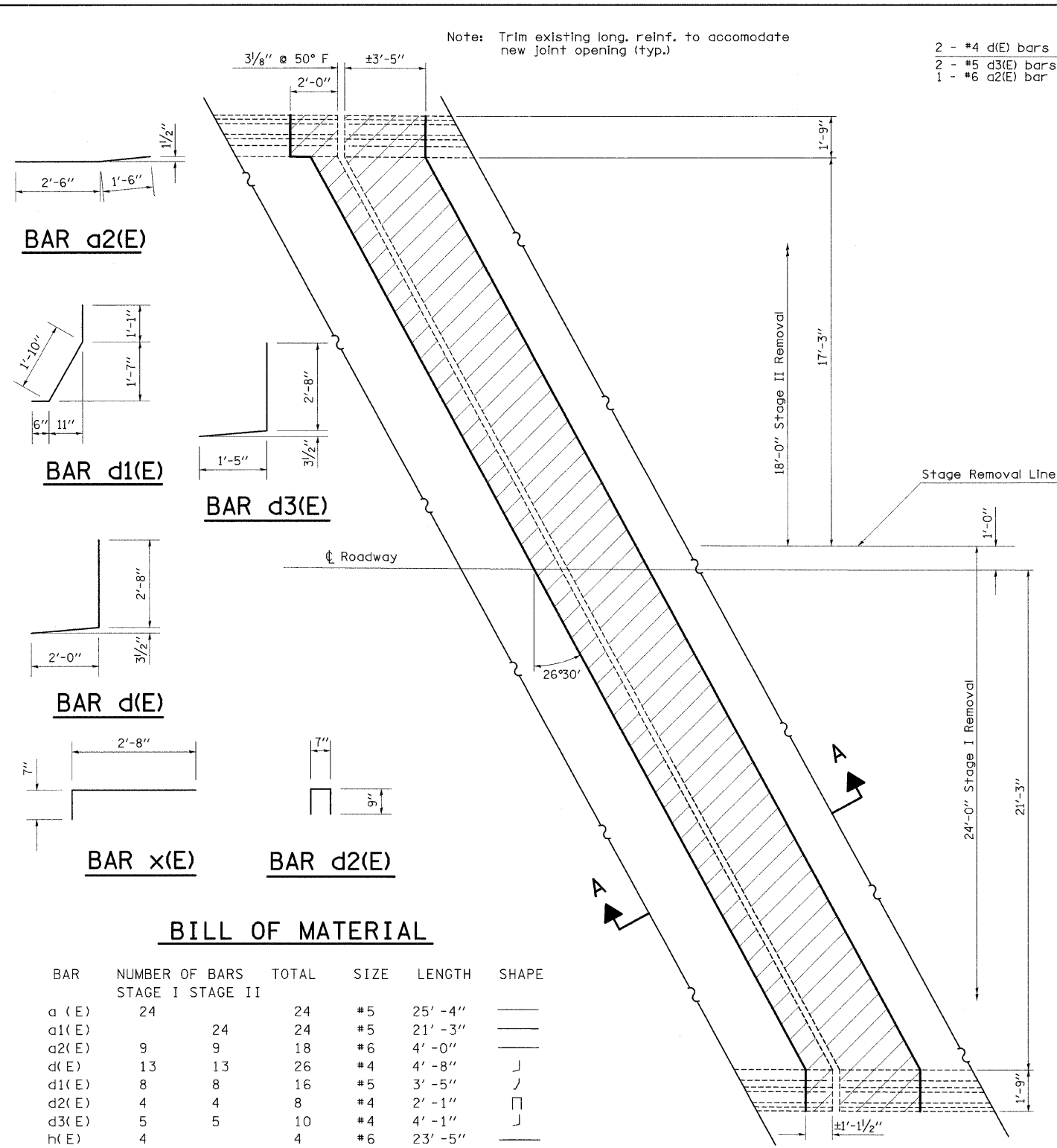

BAR a2(E)

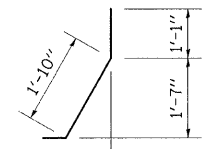

BAR d1(E)

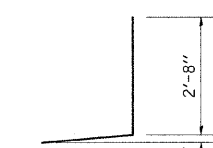

BAR d(E)

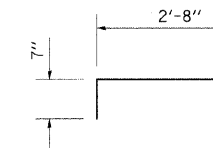

BAR x(E)



BAR d3(E)



BAR d2(E)



BILL OF MATERIAL

BAR	NUMBER OF BARS	TOTAL	SIZE	LENGTH	SHAPE
a (E)	24	24	#5	25' -4"	—
a1(E)	24	24	#5	21' -3"	—
a2(E)	9	9	#6	4' -0"	—
d (E)	13	13	#4	4' -8"	J
d1(E)	8	8	#5	3' -5"	J
d2(E)	4	4	#4	2' -1"	□
d3(E)	5	5	#4	4' -1"	J
h (E)	4	4	#6	23' -5"	—
h1(E)	4	4	#6	19' -3"	—
x(E)	50	40	#5	3' -3"	┌

CONCRETE REMOVAL	CU. YD.	11.6
REINFORCEMENT BARS (EPOXY COATED)	POUND	3410
CONCRETE SUPERSTRUCTURE	CU. YD.	13.5

REINFORCEMENT BARS DESIGNATED (E) SHALL BE EPOXY COATED

EXISTING PARTIAL PLAN
(West Abutment shown; East Abutment similar)

PROPOSED PARTIAL PLAN
(West Abutment shown; East Abutment similar)

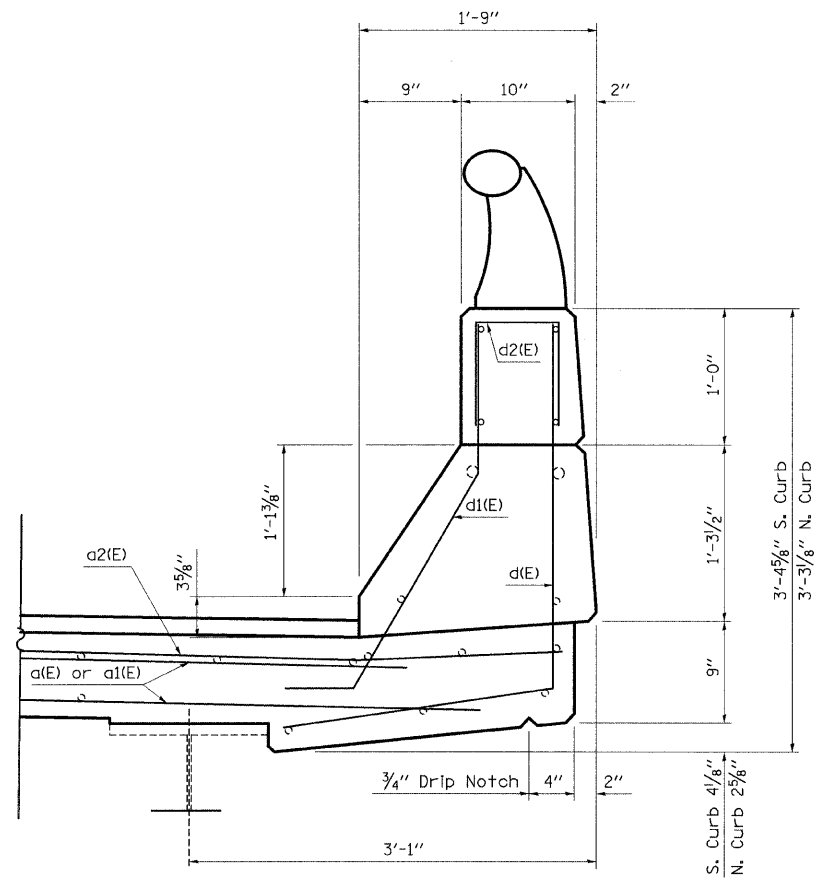

SECTION THRU DECK PARAPET

Note: Rotate d(E), d1(E) and d3(E) bars in parapet to fit horizontal legs in concrete pour.

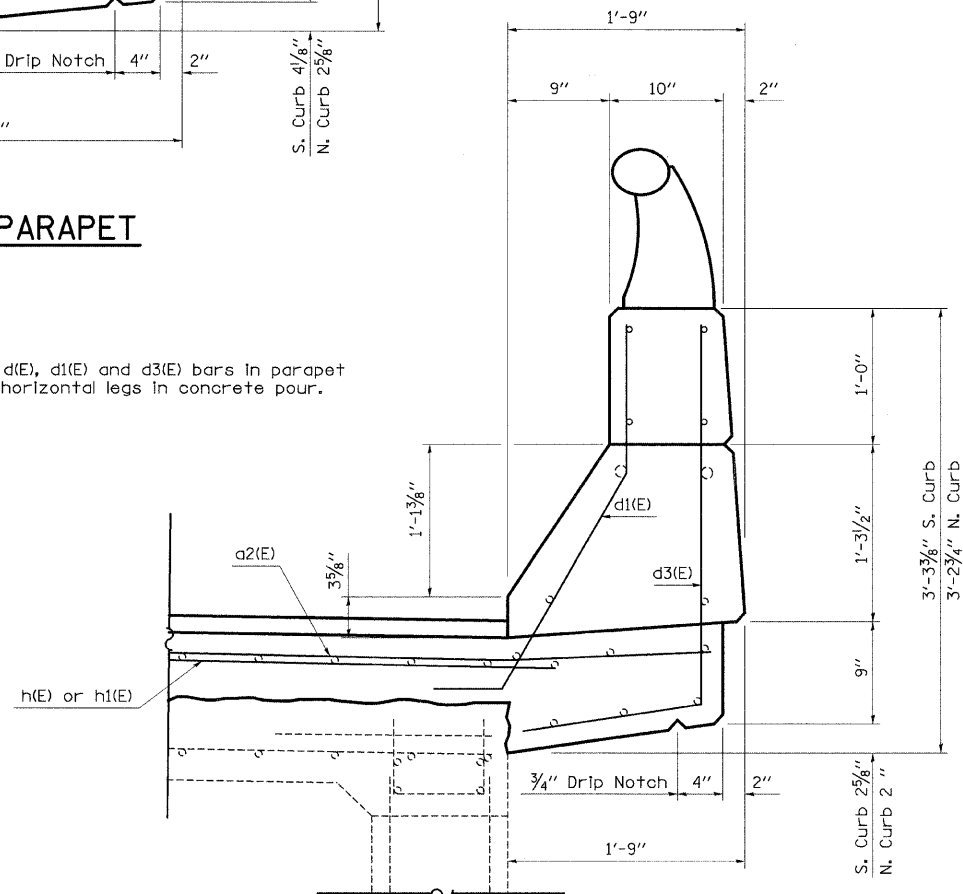

SECTION THRU APPROACH PARAPET

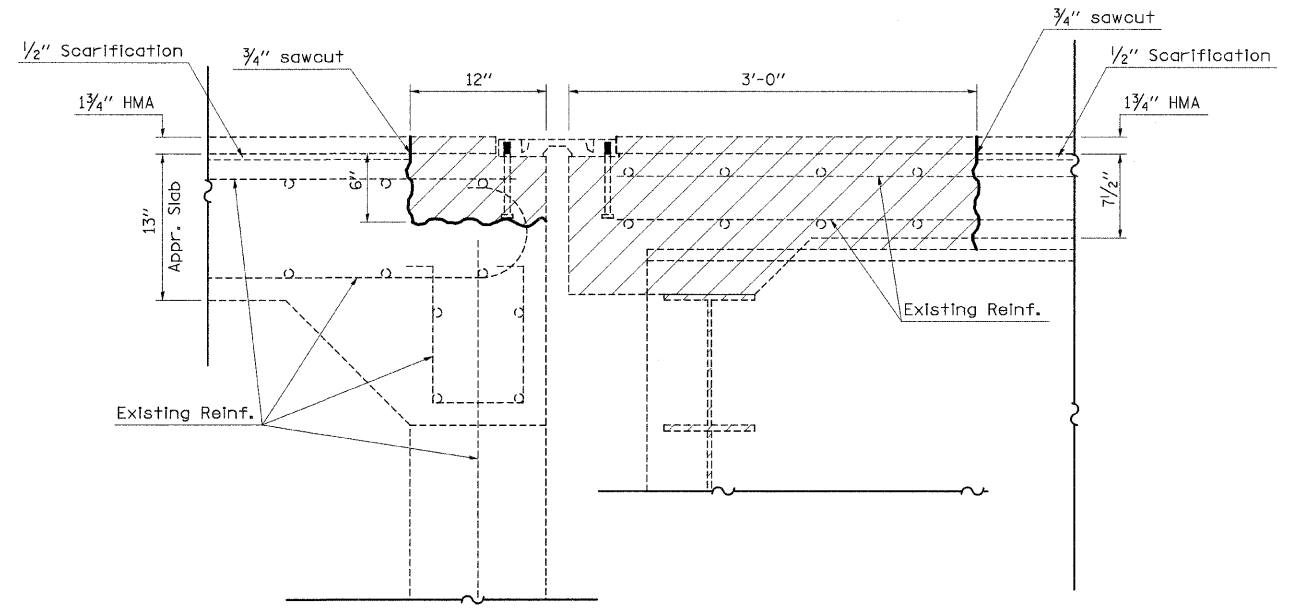

SECTION A-A
(Dimensions at RT L's to end of deck)

- Existing Reinforcement
- Proposed Reinforcement

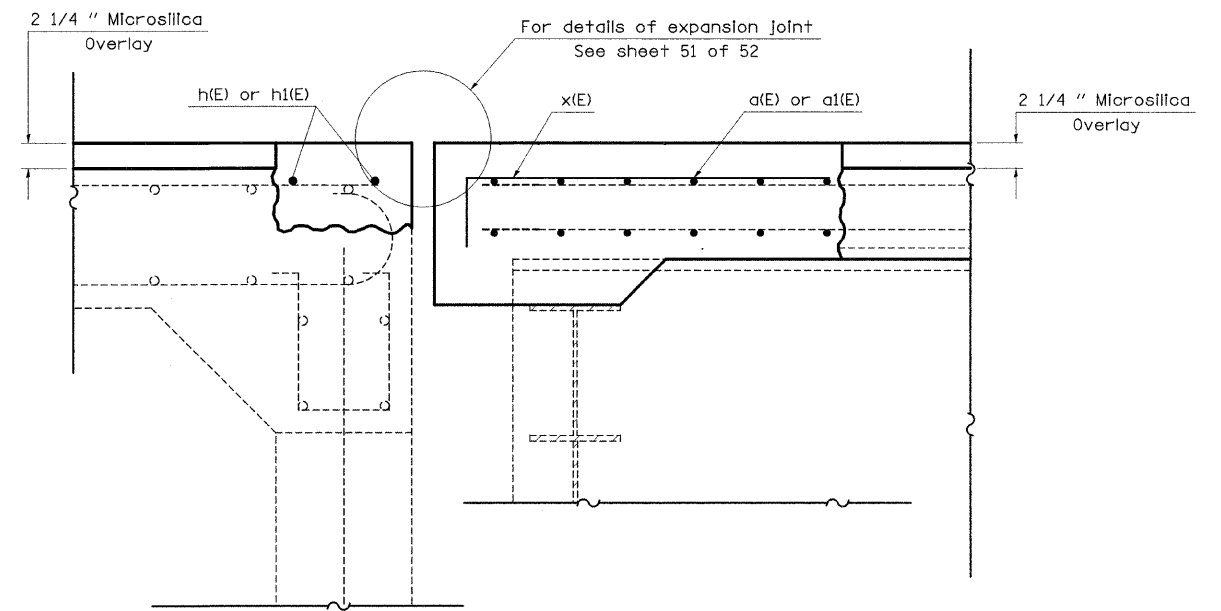

SECTION B-B
(Dimensions at RT L's to end of deck)

FILE NAME =	USER NAME = swartzrw	DESIGNED -	REVISED -	STATE OF ILLINOIS DEPARTMENT OF TRANSPORTATION	EXPANSION JOINT REPLACEMENT DETAILS SN 058-0093 (EB) & SN 058-0094 (WB)	F.A.I. RTE.	SECTION	COUNTY	TOTAL SHEETS	SHEET NO.	
c:\pwork\p\WIDOT\SWARTZRW\dms37779\k	enbridge.dgn	DRAWN -	REVISED -			72	66(B,HVB,HB-1)BR	MACON	83	32	
PLOT SCALE = 20,0000' / IN.		CHECKED -	REVISED -			CONTRACT NO. 74343					
PLOT DATE = 9/28/2009		DATE -	REVISED -			FED. ROAD DIST. NO. ILLINOIS FED. AID PROJECT					
						SCALE: N/A	SHEET NO. 5 OF 17 SHEETS	STA.	TO STA.		

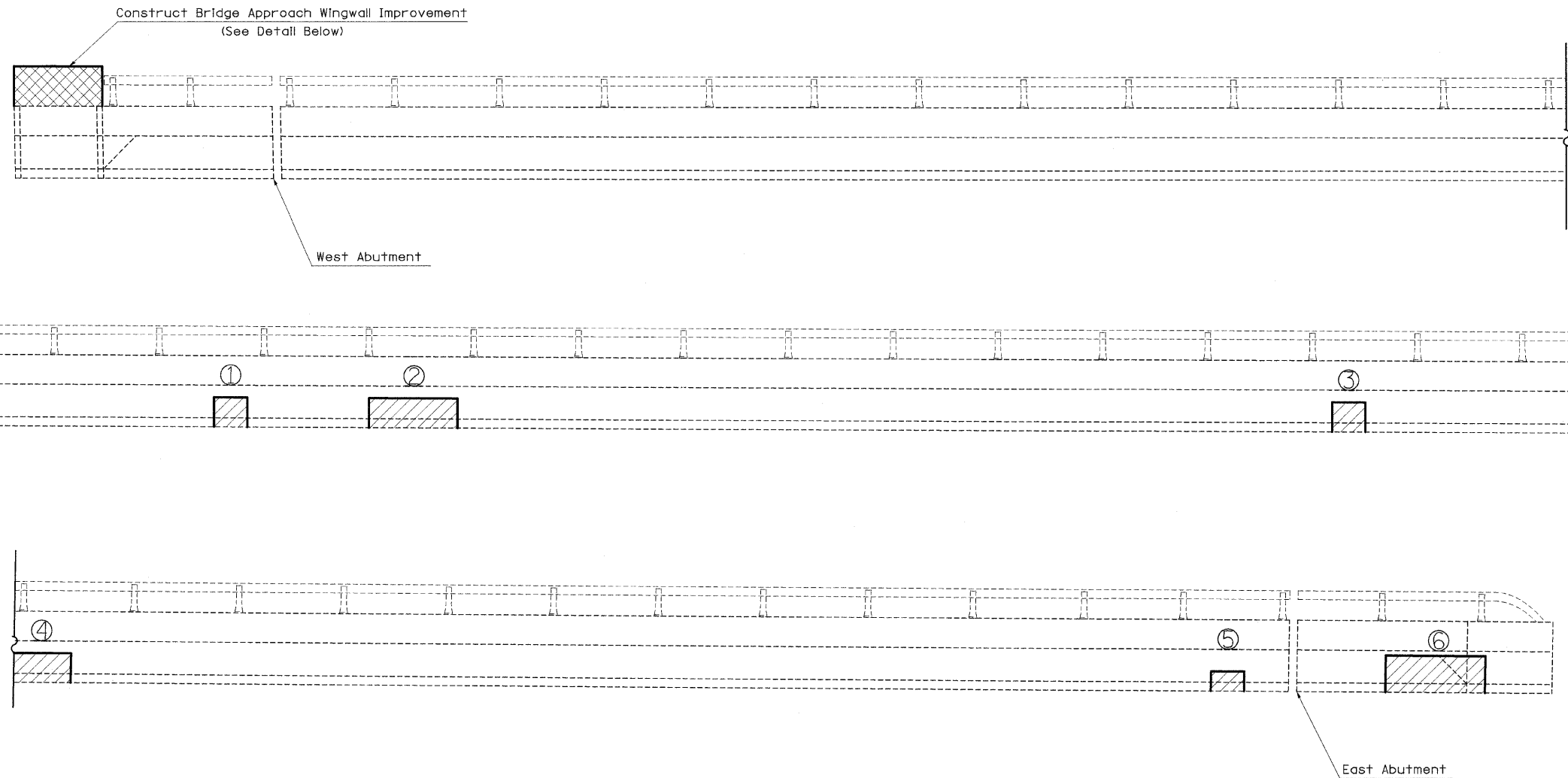

STRUCTURAL REPAIR

Cost included in Structural Repair of Concrete (Depth <5")

PATCH NUMBER	STATION	AREA SQ. FT.
1	720+75	3.0
2	720+92	8.0
3	721+76	3.0
4	722+03	7.0
5	723+10	2.0
6	723+28	11.0
	Total	31.0

NORTH PARAPET

Looking North

BILL OF MATERIAL

BAR	NUMBER OF BARS	SIZE	LENGTH	SHAPE
d8(E)	5	#5	2' - 1"	U
s(E)	9	#5	3' - 6"	□
h5(E)	4	#5	7' - 7"	
REINFORCEMENT BARS (EPOXY COATED)			POUND	80
CONCRETE SUPERSTRUCTURE			CU YD	0.3

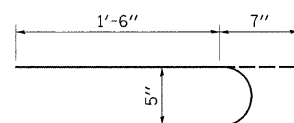

BAR d8(E)

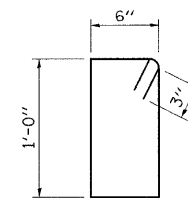

BAR s(E)

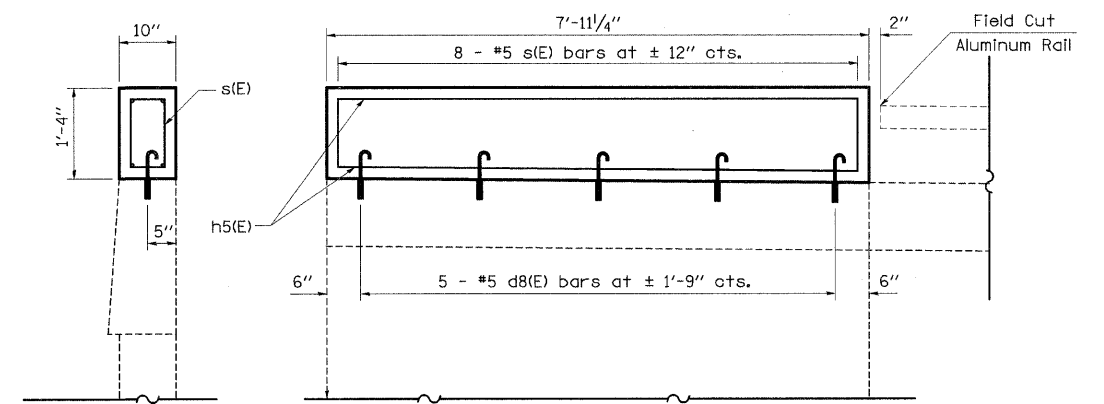

* Epoxy Grouted Bars in accordance with Art. 584 of the Standard Specs.

BRIDGE APPROACH WINGWALL IMPROVEMENT DETAIL

Northwest Wingwall Only

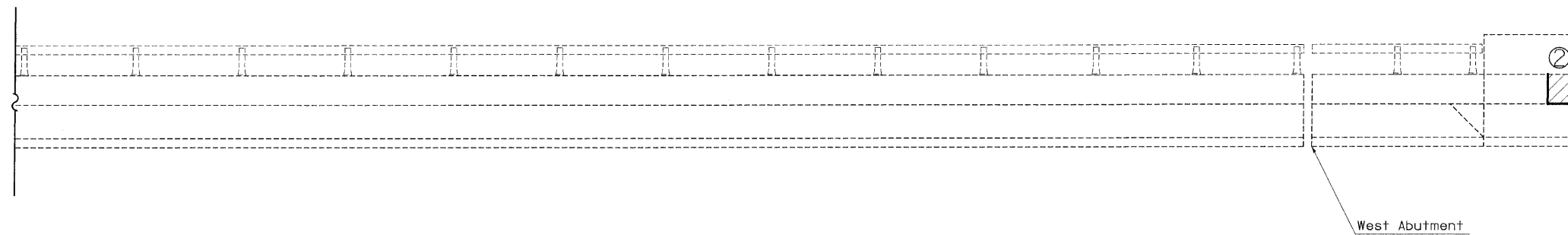
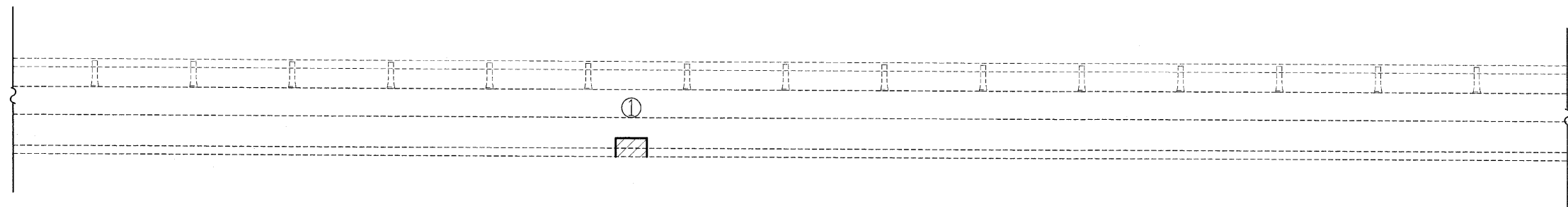
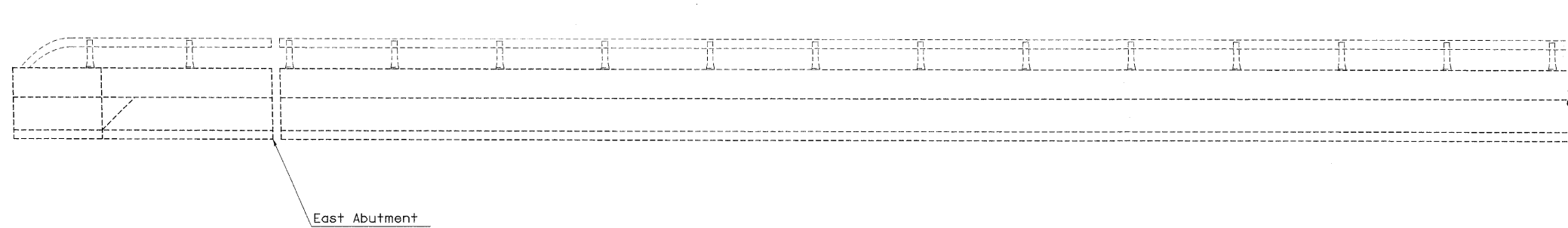

STRUCTURAL REPAIR

Cost Included in Structural Repair
of Concrete (Depth <5")

PATCH NUMBER	STATION	AREA SQ. FT.
1	721+62	2.0
2	719+65	2.0
Total		4.0

SOUTH PARAPET

Looking South

FILE NAME = c:\pw_work\PWIDOT\SWARTZR\des37779\k enbridge.dgn	USER NAME = swartzw	DESIGNED -	REVISED -	STATE OF ILLINOIS DEPARTMENT OF TRANSPORTATION	STRUCTURAL REPAIR - PARAPET SN. 058-0093 (EB)		F.A.I. RTE. 72	SECTION 66(B,HVB,HB-1)BR	COUNTY MACON	TOTAL SHEETS 83	SHEET NO. 34	
PLLOT SCALE = 28.0000' / IN.	CHECKED -	REVISED -	REVISED -		SCALE: N/A	SHEET NO. 7 OF 17 SHEETS	STA. TO STA.	CONTRACT NO. 74343				
PLLOT DATE = 9/28/2009	DATE -	REVISED -	REVISED -		FED. ROAD DIST. NO. ILLINOIS FED. AID PROJECT							

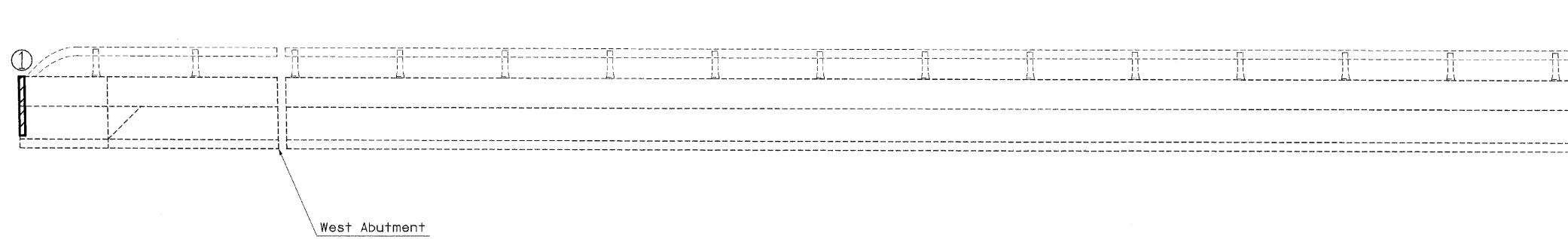

West Abutment

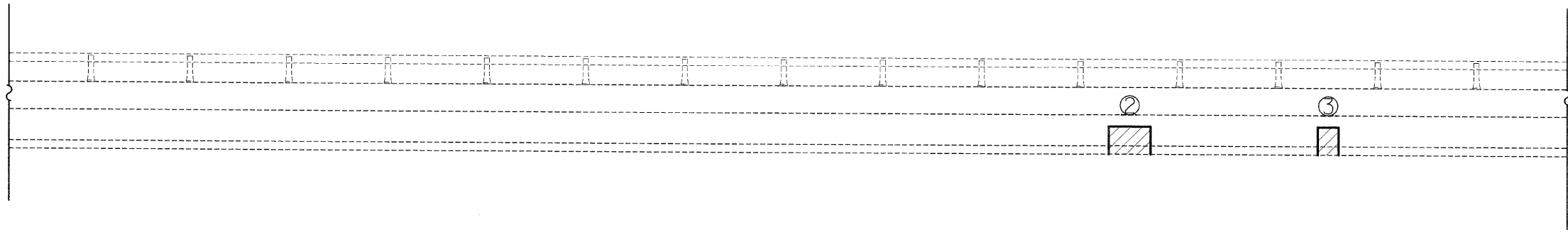

2

3

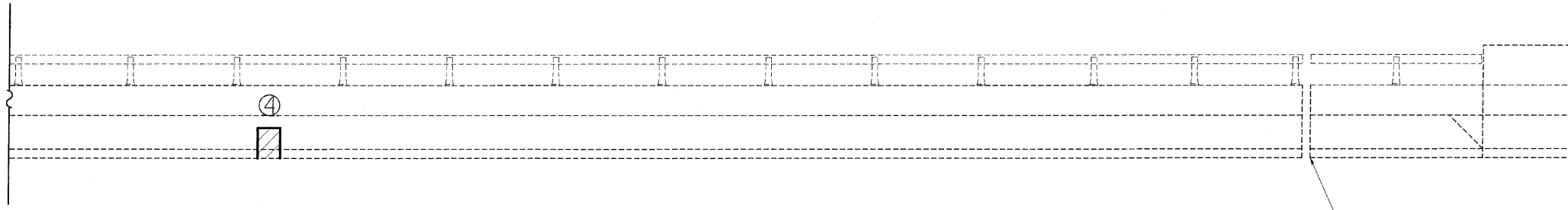

East Abutment

NORTH PARAPET
Looking North

STRUCTURAL REPAIR

Cost Included in Structural Repair
of Concrete (Depth <5")

PATCH NUMBER	STATION	AREA SQ. FT.
1	718+55	1.0
2	721+07	4.0
3	721+26	2.0
4	721+72	2.0
	Total	9.0

FILE NAME =	USER NAME = swartzw	DESIGNED -	REVISED -	STATE OF ILLINOIS DEPARTMENT OF TRANSPORTATION	STRUCTURE REPAIR - PARAPET SN. 058-0094 (WB)	F.A.I. RTE.	SECTION	COUNTY	TOTAL SHEETS	SHEET NO.
c:\pwork\pwwidot\SWARTZRW\dms37779\k	enbridge.dgn	DRAWN -	REVISED -			72	66(B,HVB,HB-1)BR	MACON	83	35
	PLOT SCALE = 20.0000' / IN.	CHECKED -	REVISED -			CONTRACT NO. 74343				
	PLOT DATE = 9/28/2009	DATE -	REVISED -			SCALE: N/A	SHEET NO. 8 OF 17 SHEETS	STA. TO STA.	FED. ROAD DIST. NO.	ILLINOIS FED. AID PROJECT

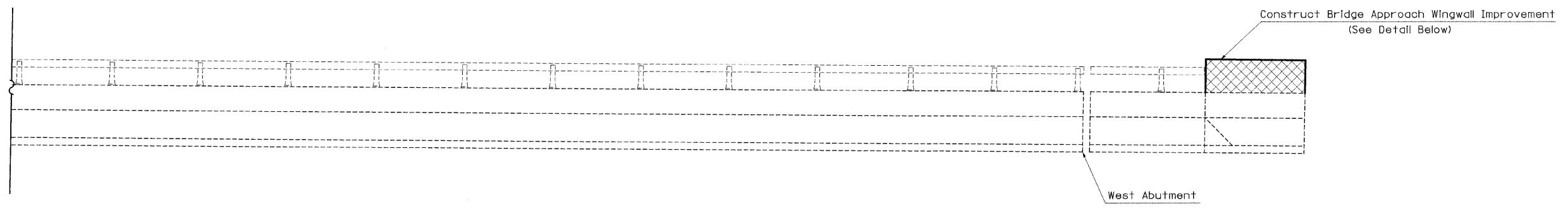
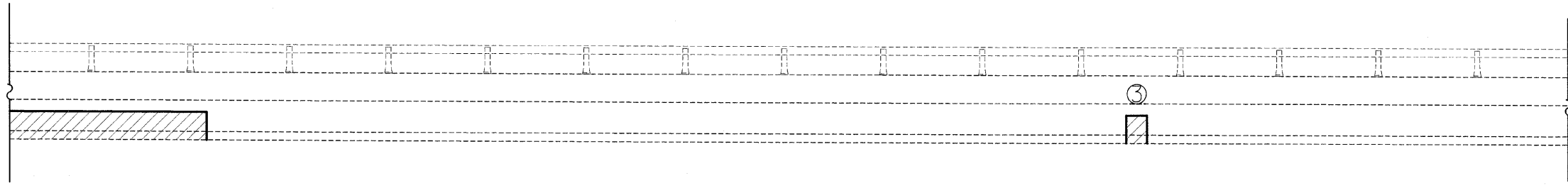
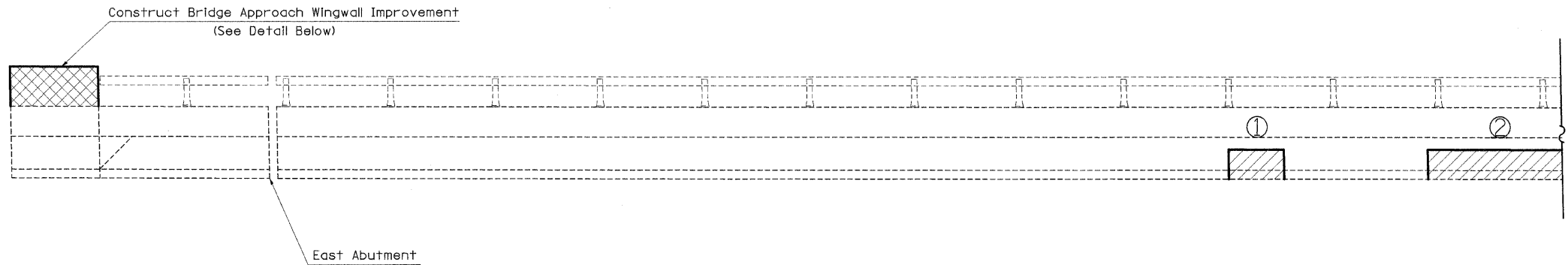

STRUCTURAL REPAIR

Cost included in Structural Repair of Concrete (Depth <5")

PATCH NUMBER	STATION	AREA SQ. FT.
1	718+55	1.0
2	721+07	4.0
3	721+26	2.0
4	721+72	2.0
Total		9.0

SOUTH PARAPET
Looking South
BILL OF MATERIAL

BAR	NUMBER OF BARS	SIZE	LENGTH	SHAPE
d8(E)	10	#5	2' - 1"	U
s(E)	18	#5	3' - 6"	□
h5(E)	4	#5	7' - 7"	—
h6(E)	4	#5	7' - 4"	—
REINFORCEMENT BARS (EPOXY COATED)			POUND	120
CONCRETE SUPERSTRUCTURE			CU YD	0.7

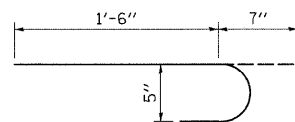

BAR d8(E)

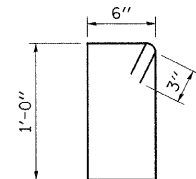

BAR s(E)

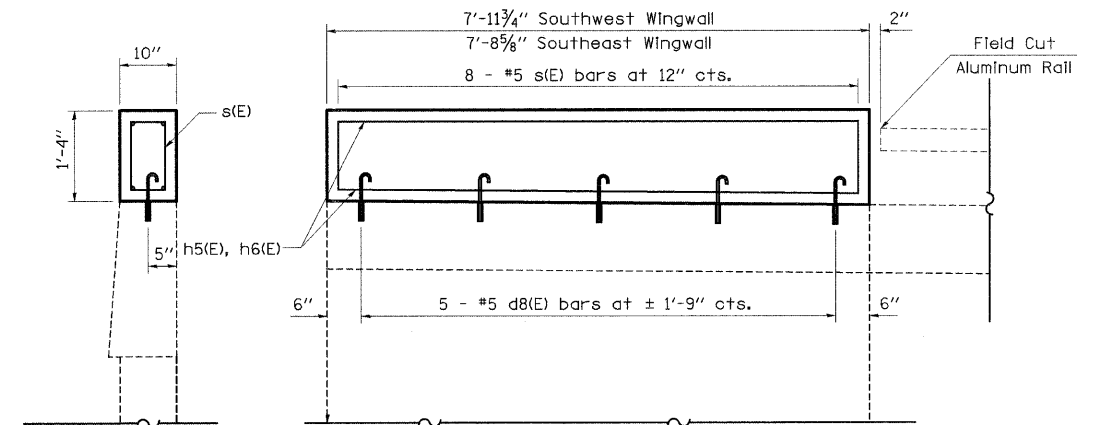

* Epoxy Grouted Bars in accordance with Art. 584 of the Standard Specs.

BRIDGE APPROACH WINGWALL IMPROVEMENT DETAIL
Southeast & Southwest Wingwalls

FILE NAME =	USER NAME = swartzw	DESIGNED -	REVISED -
ct:\pw_work\FWIDOT\SMARTZRW\dms37779\k...enbridge.dgn		DRAWN -	REVISED -
PLOT SCALE = 20,0000' / IN.		CHECKED -	REVISED -
PLOT DATE = 9/28/2009		DATE -	REVISED -

STATE OF ILLINOIS
DEPARTMENT OF TRANSPORTATION

STRUCTURE REPAIR - PARAPET
SN. 058-0094 (WB)

SCALE: N/A SHEET NO. 9 OF 17 SHEETS STA. TO STA.

F.A.I. RTE.	SECTION	COUNTY	TOTAL SHEETS	SHEET NO.
72	66(B,HVB,HB-1)BR	MACON	83	36
FED. ROAD DIST. NO.			ILLINOIS FED. AID PROJECT	
			CONTRACT NO. 74343	

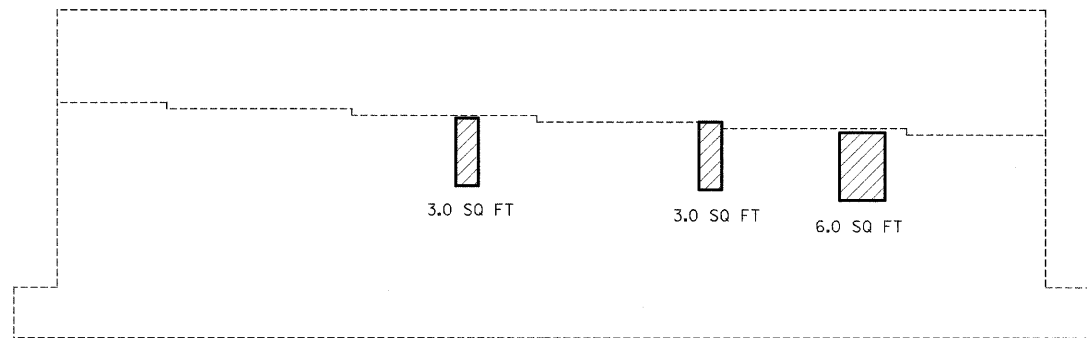

WEST ABUTMENT

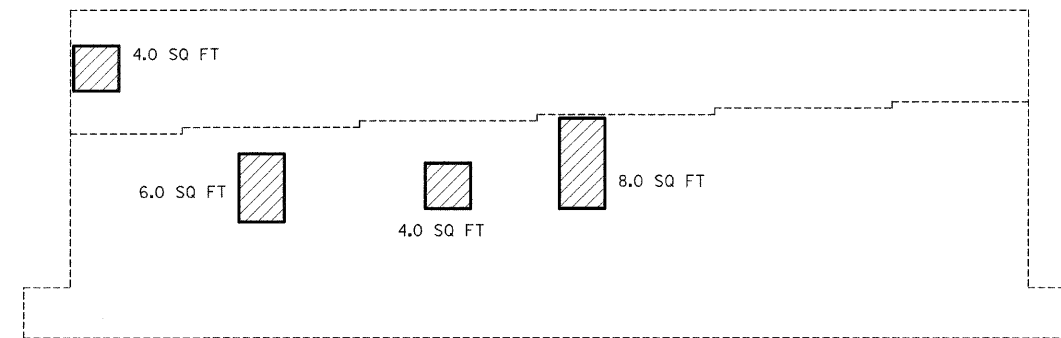

EAST ABUTMENT

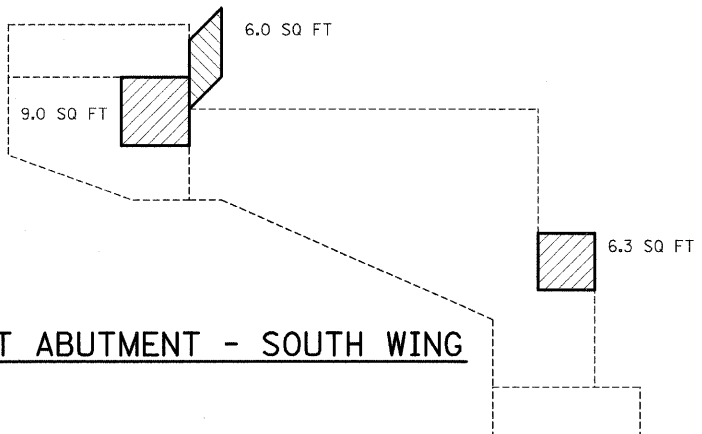

WEST ABUTMENT - SOUTH WING

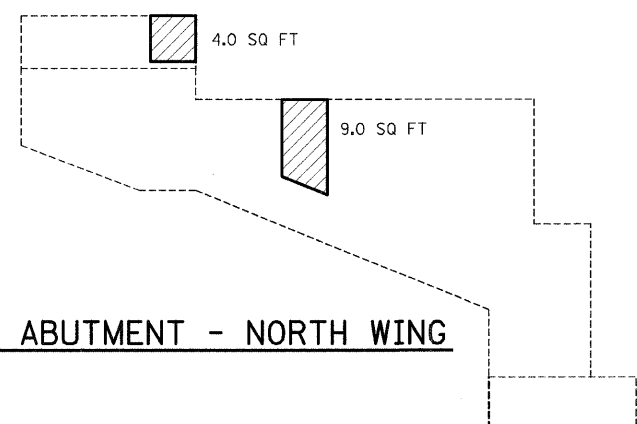

EAST ABUTMENT - NORTH WING

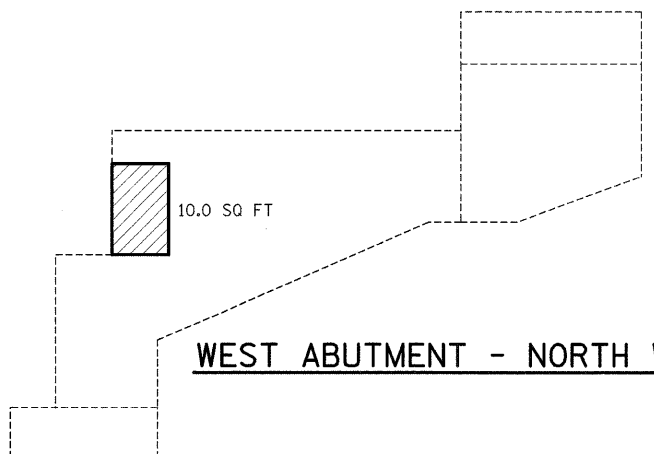

WEST ABUTMENT - NORTH WING

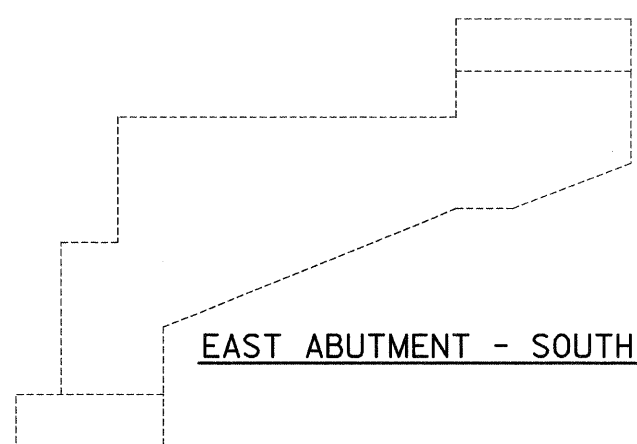

EAST ABUTMENT - SOUTH WING

NOTE: QUANTITIES ARE ESTIMATED. ACTUAL QUANTITIES TO BE DETERMINED BY THE RESIDENT ENGINEER.

 Structural Repair of Concrete (Depth < 5")

FILE NAME = c:\pwork\pwwid\SWARTZR\mas37779\k...enbridge.dgn	USER NAME = swartzrw	DESIGNED -	REVISED -	STATE OF ILLINOIS DEPARTMENT OF TRANSPORTATION	STRUCTURAL REPAIR - SUBSTRUCTURE SN 058-0093 (EB)		F.A.I. RTE.	SECTION	COUNTY	TOTAL SHEETS	SHEET NO.	
	PLOT SCALE = 20.0000' / 1" IN.	DRAWN -	REVISED -		SCALE: N/A	SHEET NO. 10 OF 17 SHEETS	STA.	72	66(B,HVB,HB-1)BR	MACON	83	37
	PLOT DATE = 9/28/2009	CHECKED -	REVISED -		TO STA.			CONTRACT NO. 74343				
							FED. ROAD DIST. NO. ILLINOIS FED. AID PROJECT					

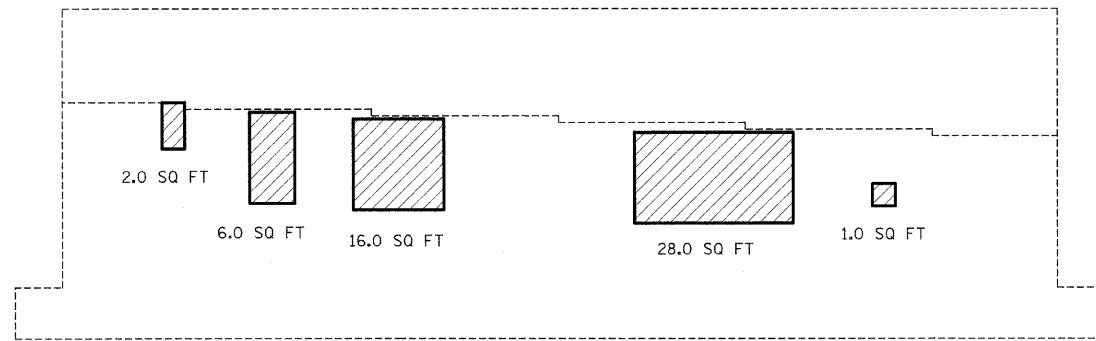

WEST ABUTMENT

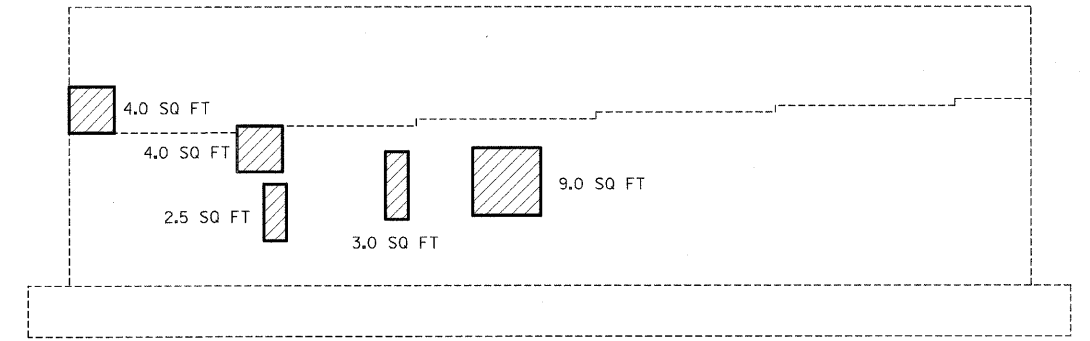

EAST ABUTMENT

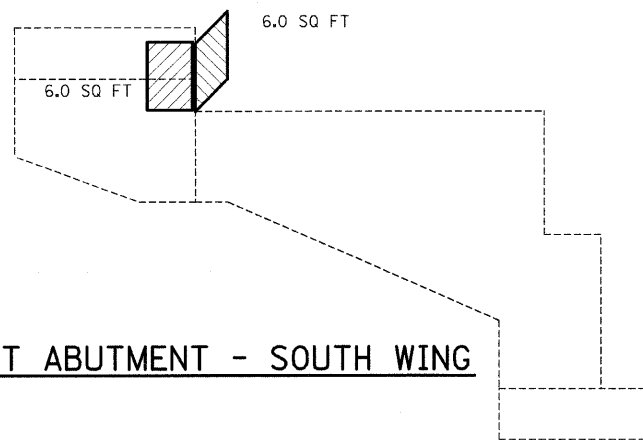

WEST ABUTMENT - SOUTH WING

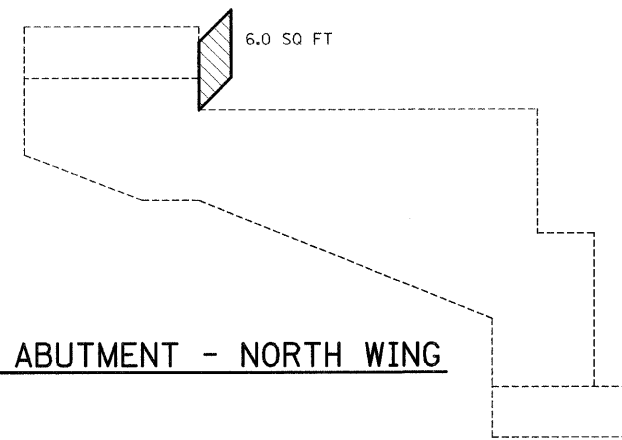

EAST ABUTMENT - NORTH WING

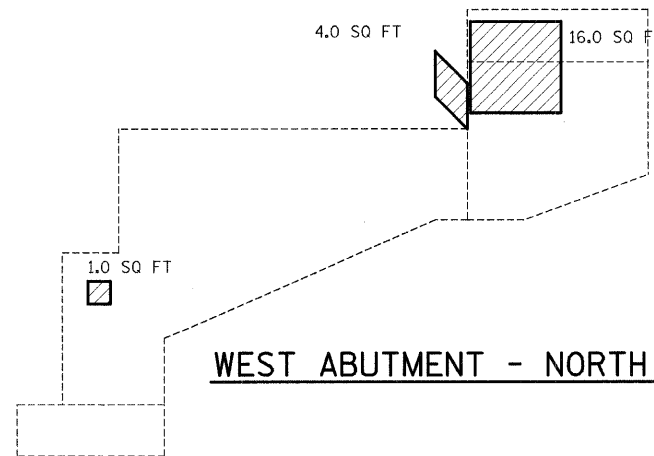

WEST ABUTMENT - NORTH WING

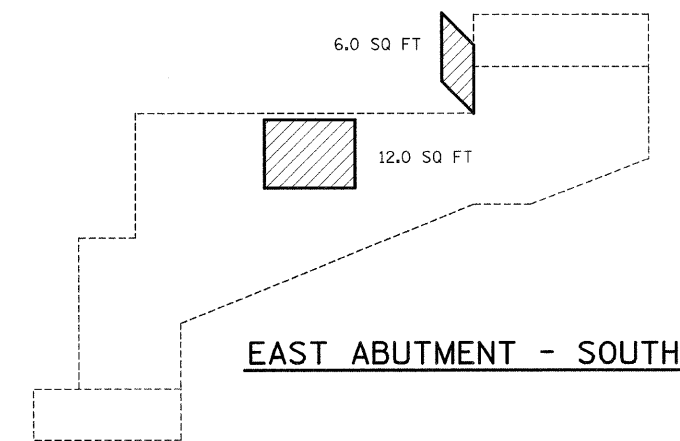

EAST ABUTMENT - SOUTH WING

 Structural Repair of Concrete (Depth < 5")

NOTE: QUANTITIES ARE ESTIMATED. ACTUAL QUANTITIES TO BE DETERMINED BY THE RESIDENT ENGINEER.

FILE NAME =	USER NAME = swartzw	DESIGNED -	REVISED -
c:\pwork\FWIDOT\SWARTZRW\dms37779\k	enbridge.dgn	DRAWN -	REVISED -
	PLOT SCALE = 20.0000' / IN.	CHECKED -	REVISED -
	PLOT DATE = 9/28/2009	DATE -	REVISED -

**STATE OF ILLINOIS
DEPARTMENT OF TRANSPORTATION**

**STRUCTURAL REPAIR - SUBSTRUCTURE
058-0094 (WB)**

SCALE: N/A SHEET NO. 11 OF 17 SHEETS STA. TO STA.

F.A.I. RTE.	SECTION	COUNTY	TOTAL SHEETS	SHEET NO.
72	66(B),HVB,HB-1BR	MACON	83	38
FED. ROAD DIST. NO. ILLINOIS FED. AID PROJECT			CONTRACT NO. 74343	

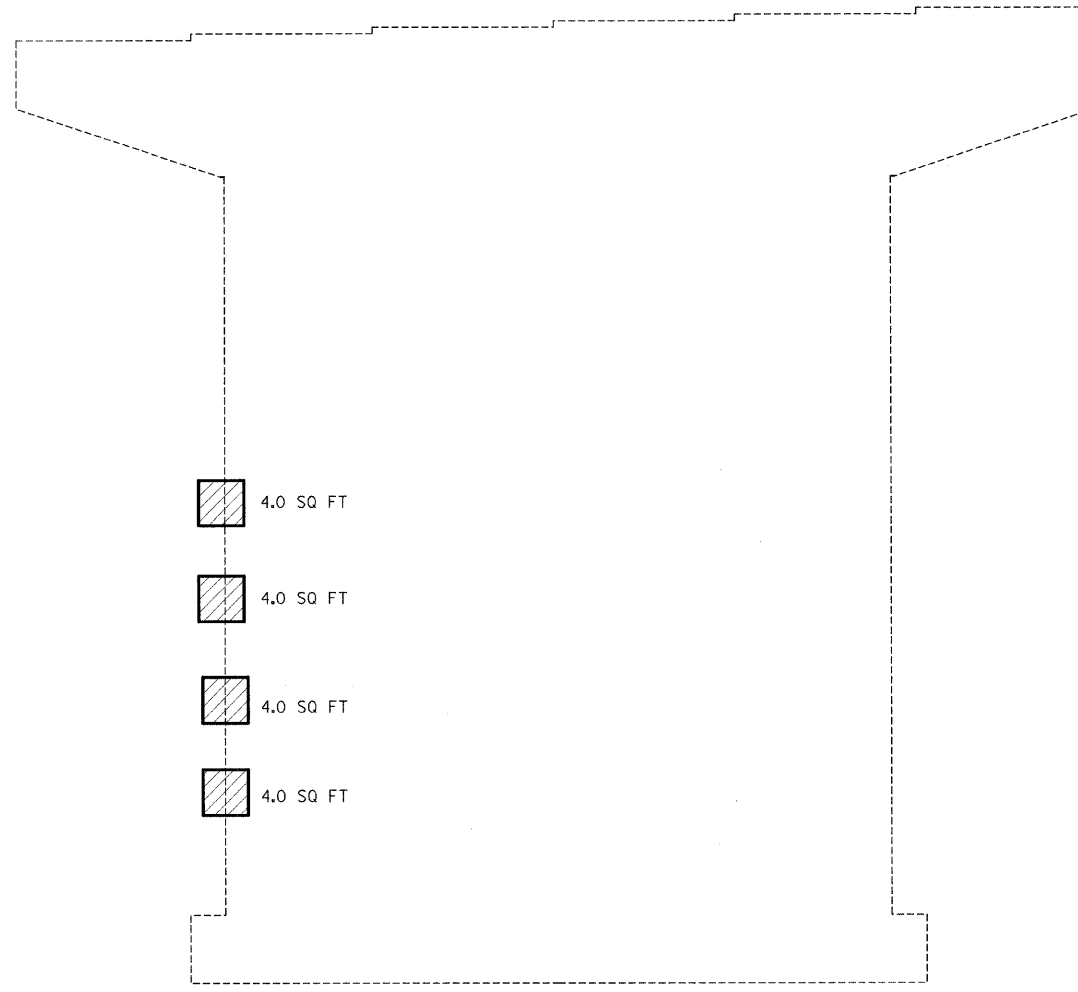

PIER #1 - WEST FACE
SN 058-0094 (WB)

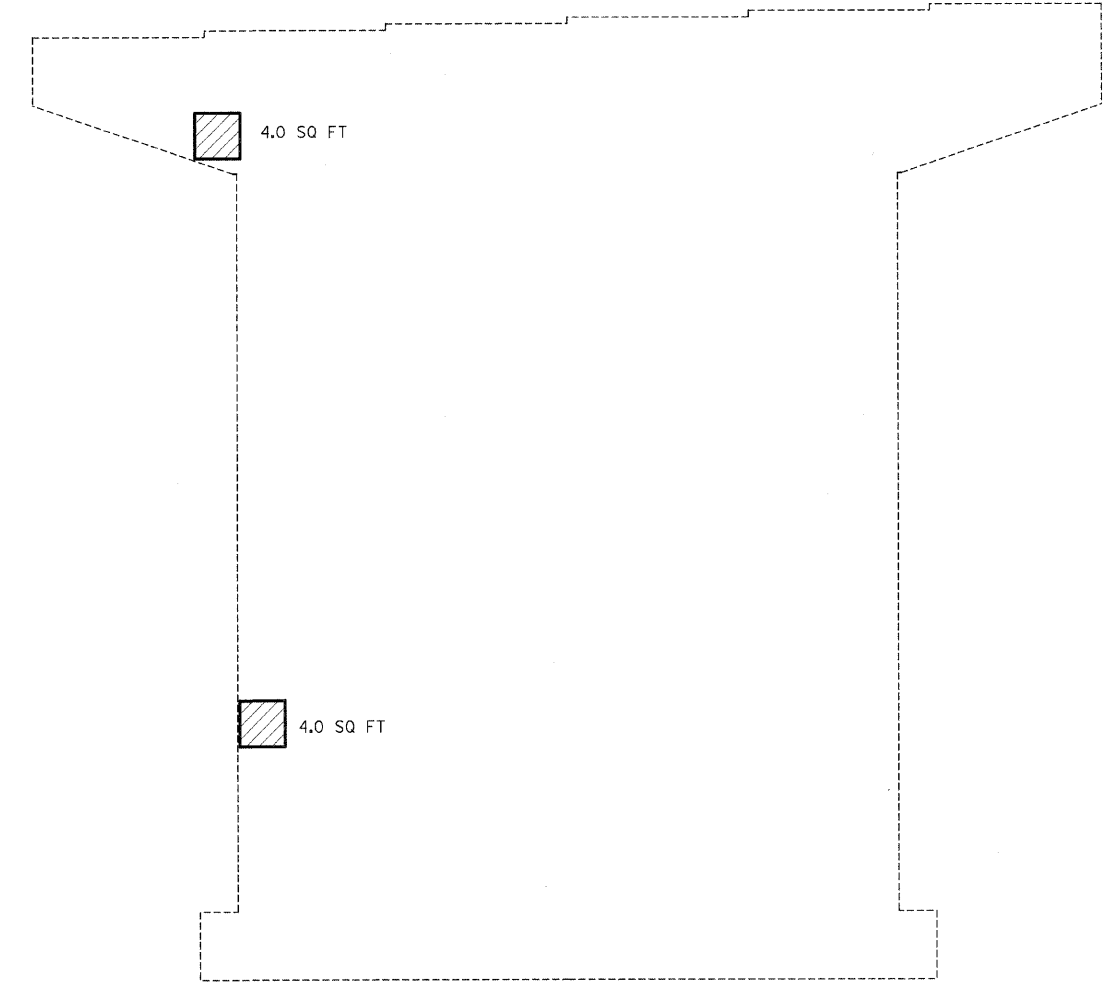

PIER #1 - WEST FACE
SN 058-0093 (EB)

NOTE: QUANTITIES ARE ESTIMATED. ACTUAL QUANTITIES TO BE DETERMINED BY THE RESIDENT ENGINEER.

 Structural Repair of Concrete (Depth < 5")

FILE NAME = c:\pw_work\PWIDOT\SWARTZRN\dms37779\k...enbridge.dgn	USER NAME = swartzrn	DESIGNED -	REVISED -	STATE OF ILLINOIS DEPARTMENT OF TRANSPORTATION	STRUCTURAL REPAIR - SUBSTRUCTURE SN 058-0093 (EB) & SN 058-0094 (WB)		F.A.I. RTE.	SECTION	COUNTY	TOTAL SHEETS	SHEET NO.	
PLOT SCALE = 20,0000' / IN.	CHECKED -	REVISED -	72				66(B,HVB,HB-1)BR	MACON	83	39		
PLOT DATE = 9/28/2009	DATE -	REVISED -	SCALE: N/A		SHEET NO. 12 OF 17 SHEETS	STA.	TO STA.	FED. ROAD DIST. NO. ILLINOIS FED. AID PROJECT				
								CONTRACT NO. 74343				

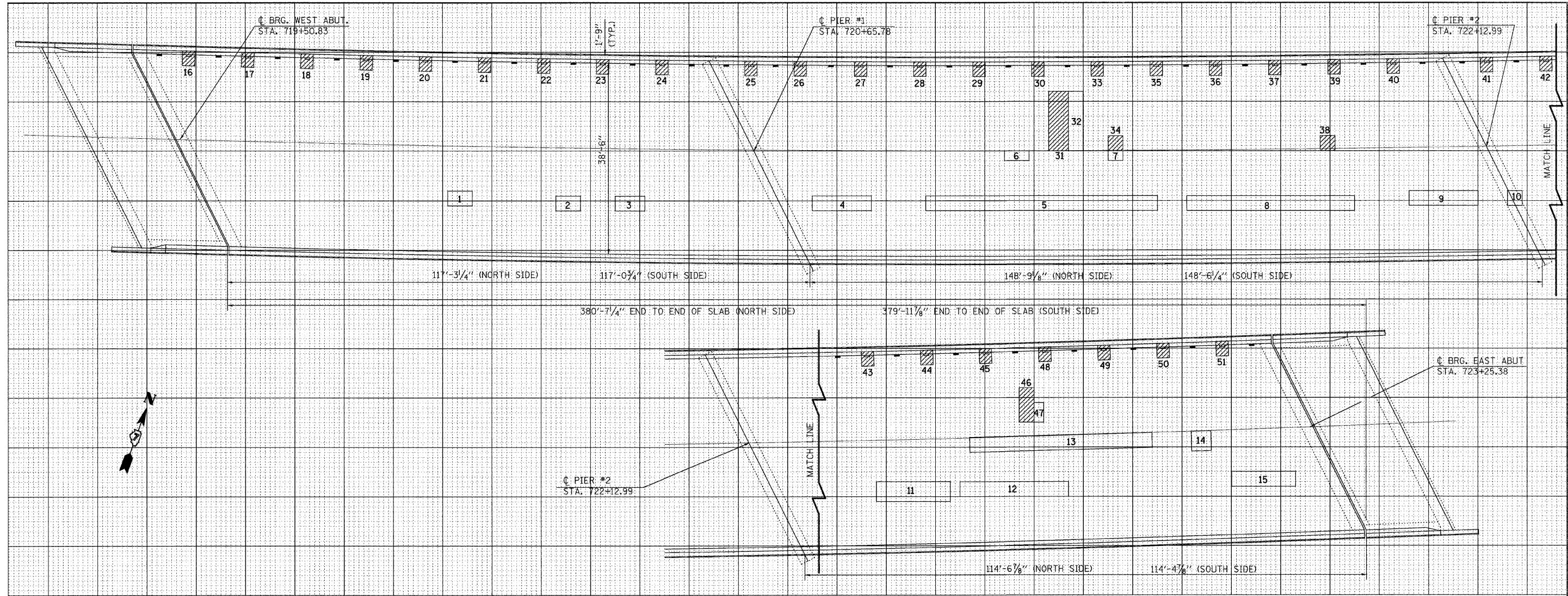

PATCH NO.	SIZE	DECK SLAB REPAIR (PART DEPTH)			DECK SLAB REPAIR (FD TY 2)
		SQ FT	SQ FT	SQ FT	
1	5.0 x 3.0	15.0			
2	5.0 x 3.0	15.0			
3	6.0 x 3.0	18.0			
4	12.0 x 3.0	36.0			
5	47.0 x 3.0	141.0			
6	5.0 x 2.0	10.0			
7	3.0 x 2.0	6.0			
8	34.0 x 3.0	102.0			
9	14.0 x 3.0	42.0			
10	3.0 x 3.0	9.0			
11	15.0 x 4.0	60.0			
12	22.0 x 3.0	66.0			
13	37.0 x 3.0	111.0			
14	4.0 x 4.0				
15	13.0 x 3.0	39.0			
16	1.8 x 1.2		2.2		
17	1.8 x 1.2		2.2		
18	1.8 x 1.2		2.2		

PATCH NO.	SIZE	DECK SLAB REPAIR (PART DEPTH)			DECK SLAB REPAIR (FD TY 2)
		SQ FT	SQ FT	SQ FT	
19	1.8 x 1.2		2.2		
20	1.8 x 1.2		2.2		
21	1.8 x 1.2		2.2		
22	1.8 x 1.2		2.2		
23	1.8 x 1.2		2.2		
24	1.8 x 1.2		2.2		
25	1.8 x 1.2		2.2		
26	1.8 x 1.2		2.2		
27	1.8 x 1.2		2.2		
28	1.8 x 1.2		2.2		
29	1.8 x 1.2		2.2		
30	1.8 x 1.2		2.2		
31	4.0 x 12.0			48.0	
32	3.0 x 12.0	36.0			
33	1.8 x 1.2		2.2		
34	3.0 x 3.0			9.0	
35	1.8 x 1.2		2.2		
36	1.8 x 1.2		2.2		

PATCH NO.	SIZE	DECK SLAB REPAIR (PART DEPTH)			DECK SLAB REPAIR (FD TY 2)
		SQ FT	SQ FT	SQ FT	
37	1.8 x 1.2		2.2		
38	3.0 x 3.0			9.0	
39	1.8 x 1.2		2.2		
40	1.8 x 1.2		2.2		
41	1.8 x 1.2		2.2		
42	1.8 x 1.2		2.2		
43	1.8 x 1.2		2.2		
44	1.8 x 1.2		2.2		
45	1.8 x 1.2		2.2		
46	3.0 x 7.0			21.0	
47	2.0 x 4.0	8.0			
48	1.8 x 1.2		2.2		
49	1.8 x 1.2		2.2		
50	1.8 x 1.2		2.2		
51	1.8 x 1.2		2.2		
TOTAL		714	66	87	0

PATCH NO.	SIZE	DECK SLAB REPAIR (PART DEPTH)			DECK SLAB REPAIR (FD TY 2)
		SQ FT	SQ FT	SQ FT	
PARTIAL DEPTH					
714 / 9 =	79.3				
USE	79		SQ YD		
FULL DEPTH, TYPE 1					
66 / 9 =	7.3				
USE	7		SQ YD		
FULL DEPTH, TYPE 2					
87 / 9 =	9.7				
USE	10		SQ YD		

PATCH NO.	SIZE	DECK SLAB REPAIR (PART DEPTH)			DECK SLAB REPAIR (FD TY 1)	DECK SLAB REPAIR (FD TY 2)
		SQ FT	SQ FT	SQ FT		

THE LOCATIONS AND SIZES SHOWN GRAPHICALLY ABOVE ARE APPROXIMATE. SEE THIS TABLE FOR ACTUAL SIZES.

PATCHING LEGEND

- PARTIAL DEPTH (FOR INFORMATION ONLY)
- FULL DEPTH
- FLOOR DRAIN TO BE REPLACED
- FLOOR DRAIN TO BE PLUGGED

DATE OF SURVEY: 10/31/07
SURVEY BY: M. ALLEN, K. THOLE
METHOD OF SURVEY: VISUAL

BRIDGE DECK PATCHING
MACON COUNTY

093

FILE NAME = C:\pw\work\PROJECTS\SMART2R\GIS\37779\KARD\bridge.dgn
USER NAME = swartzw
PLOT SCALE = 50,0000' / IN.
PLOT DATE = 9/28/2009

DESIGNED -
DRAWN -
CHECKED -
DATE -

REVISED -
REVISED -
REVISED -
REVISED -

STATE OF ILLINOIS
DEPARTMENT OF TRANSPORTATION

DECK SLAB REPAIR
S.N. 058-0093 (E.B.)
SCALE: 50 SHEET NO. 13 OF 17 SHEETS STA. TO STA.

F.A.I. RTE.	SECTION	COUNTY	TOTAL SHEETS	SHEET NO.
72	66(B,HVB,HB-1)BR	MACON	83	40
CONTRACT NO. 74343				
FED. ROAD DIST. NO. ILLINOIS FED. AID PROJECT				

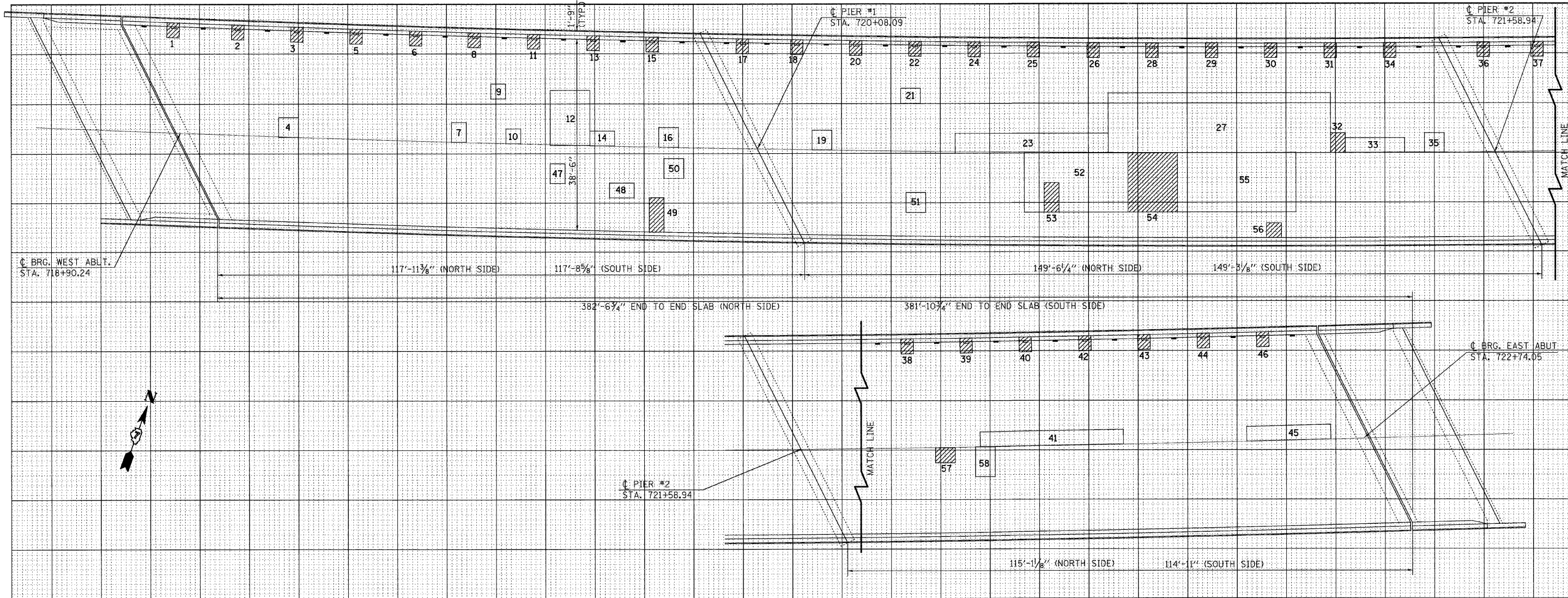

PATCH NO.	SIZE	DECK SLAB REPAIR (PART DEPTH)		
		SO FT	SO FT	SO FT
1	1.8 x 1.2		2.2	
2	1.8 x 1.2		2.2	
3	1.8 x 1.2		2.2	
4	4.0 x 4.0	16.0		
5	1.8 x 1.2		2.2	
6	1.8 x 1.2		2.2	
7	3.0 x 4.0	12.0		
8	1.8 x 1.2		2.2	
9	3.0 x 3.0	9.0		
10	3.0 x 3.0	9.0		
11	1.8 x 1.2		2.2	
12	8.0 x 11.0	88.0		
13	1.8 x 1.2		2.2	
14	5.0 x 3.0			
15	1.8 x 1.2		2.2	
16	4.0 x 4.0	16.0		
17	1.8 x 1.2		2.2	
18	1.8 x 1.2		2.2	

PATCH NO.	SIZE	DECK SLAB REPAIR (PART DEPTH)		
		SO FT	SO FT	SO FT
19	4.0 x 4.0	16.0		
20	1.8 x 1.2		2.2	
21	4.0 x 3.0	12.0		
22	1.8 x 1.2		2.2	
23	31.0 x 4.0	124.0		
24	1.8 x 1.2		2.2	
25	1.8 x 1.2		2.2	
26	1.8 x 1.2		2.2	
27	45.0 x 12.0	540.0		
28	1.8 x 1.2		2.2	
29	1.8 x 1.2		2.2	
30	1.8 x 1.2		2.2	
31	1.8 x 1.2		2.2	
32	3.0 x 4.0			12.0
33	12.0 x 3.0	36.0		
34	1.8 x 1.2		2.2	
35	4.0 x 4.0	16.0		
36	1.8 x 1.2		2.2	

PATCH NO.	SIZE	DECK SLAB REPAIR (PART DEPTH)		
		SO FT	SO FT	SO FT
37	1.8 x 1.2		2.2	
38	1.8 x 1.2		2.2	
39	1.8 x 1.2		2.2	
40	1.8 x 1.2		2.2	
41	29.0 x 3.0	87.0		
42	1.8 x 1.2		2.2	
43	1.8 x 1.2		2.2	
44	1.8 x 1.2		2.2	
45	17.0 x 3.0	51.0		
46	1.8 x 1.2		2.2	
47	3.0 x 4.0	12.0		
48	5.0 x 3.0	15.0		
49	3.0 x 7.0			21.0
50	4.0 x 4.0	16.0		
51	4.0 x 4.0	16.0		
52	5.0 x 12.0	60.0		
	3.0 x 6.0	18.0		
	14.0 x 12.0	168.0		

PATCH NO.	SIZE	DECK SLAB REPAIR (PART DEPTH)		
		SO FT	SO FT	SO FT
53	3.0 x 6.0	18.0		
54	10.0 x 12.0			120.0
55	24.0 x 12.0	288.0		
56	3.0 x 3.0	9.0		
57	4.0 x 3.0			12.0
58	4.0 x 6.0	24.0		
	TOTAL	1676	66	165
			0	

PATCH NO.	SIZE	DECK SLAB REPAIR (PART DEPTH)		
		SO FT	SO FT	SO FT
	PARTIAL DEPTH			
	1676 / 9 =	186.2		
	USE	186	SQ YD	
	FULL DEPTH, TYPE 1			
	66 / 9 =	7.3		
	USE	7	SQ YD	
	FULL DEPTH, TYPE 2			
	165 / 9 =	18.3		
	USE	18	SQ YD	

THE LOCATIONS AND SIZES SHOWN GRAPHICALLY ABOVE ARE APPROXIMATE. SEE THIS TABLE FOR ACTUAL SIZES.

PATCHING LEGEND

- PARTIAL DEPTH (FOR INFORMATION ONLY)
- FULL DEPTH
- FLOOR DRAIN TO BE REPLACED
- FLOOR DRAIN TO BE PLUGGED

DATE OF SURVEY: 10/31/07
 SURVEY BY: M. ALLEN, K. THOEL
 METHOD OF SURVEY: VISUAL

BRIDGE DECK PATCHING
 MACON COUNTY

094

FILE NAME =	USER NAME = swart2rw	DESIGNED -	REVISED -				
cs:\pw\work\PWIDOT\SWART2RW\dms37779\kardb\bridge.dgn		DRAWN -	REVISED -				
	PLOT SCALE = 50.0000' / IN.	CHECKED -	REVISED -				
	PLOT DATE = 9/28/2009	DATE -	REVISED -				

STATE OF ILLINOIS
DEPARTMENT OF TRANSPORTATION

DECK SLAB REPAIR
S.N. 058-0094 (W.B.)

SCALE: 50	SHEET NO. 14 OF 17 SHEETS	STA.	TO STA.	F.A.I. RTE. 72	SECTION 66(B),HVB,HB-1BR	COUNTY MACON	TOTAL SHEETS 83	SHEET NO. 41
				FED. ROAD DIST. NO.		ILLINOIS FED. AID PROJECT		

CONTRACT NO. 74343

STATE OF ILLINOIS
DEPARTMENT OF TRANSPORTATION

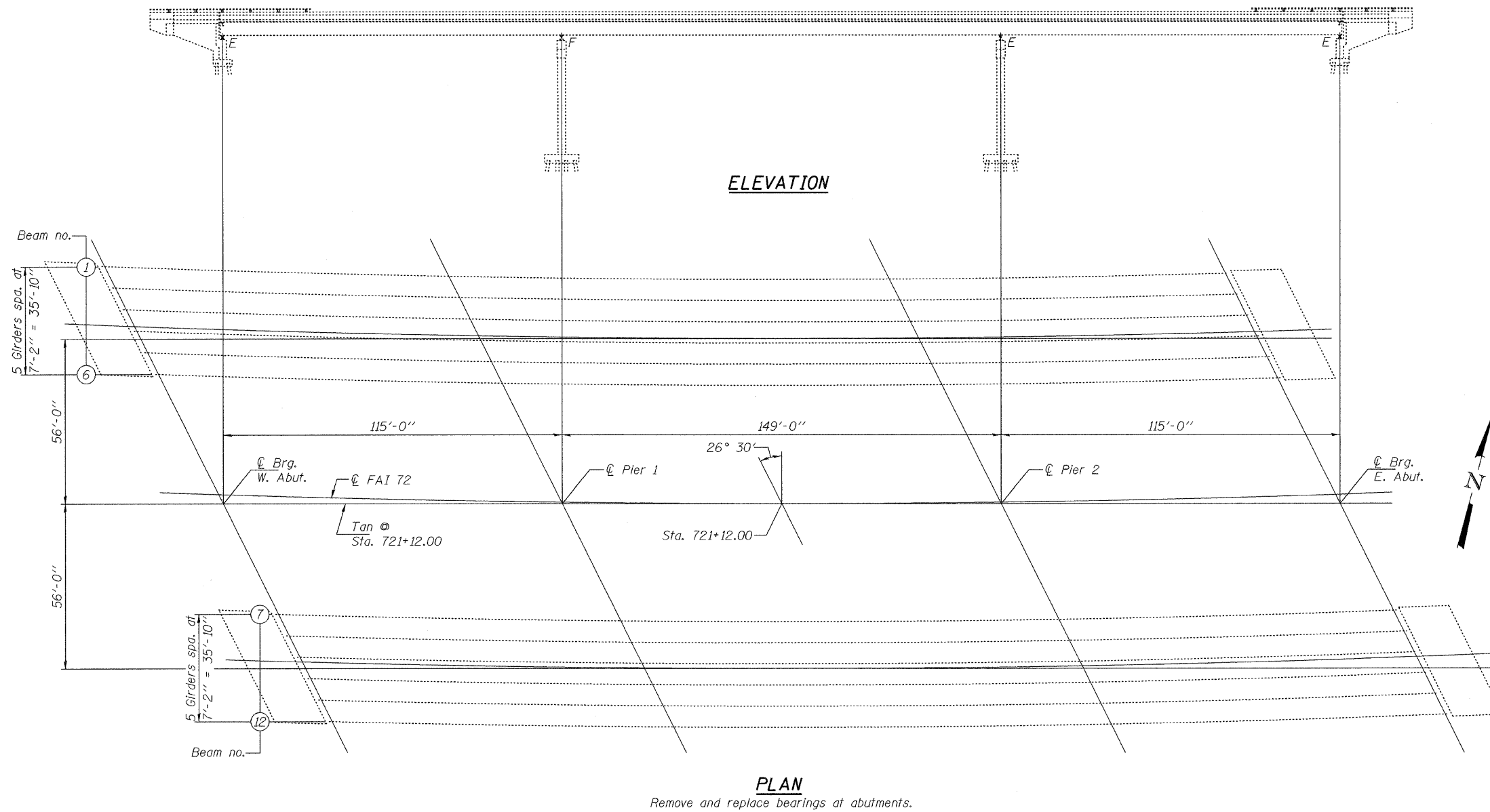

NOTES

All structural steel shall conform to AASHTO Classification M-270 Gr. 36, unless otherwise noted.
 Plan dimensions and details relative to existing plans are subject to routine variations. The Contractor shall field verify existing dimensions and details affecting new construction and make necessary approved adjustments prior to construction or ordering of materials. Such variations shall not be cause for additional compensation for a change in scope of the work, however, the Contractor will be paid for the quantity actually furnished based upon the unit price bid for the work.
 If the analysis submitted to the Contractor for the jacking/temporary support system to be used shows temporary stiffeners are required to prevent web crippling or buckling, the stiffeners shall be steel and bolted to the web. If stiffeners are not required, hardwood timbers shall be installed tightly between the top and bottom flange to prevent flange rotation.
 The existing structural steel coating contains lead. The Contractor shall take appropriate precautions to deal with the presence of lead on this project.
 Existing structural steel that will be in contact with new structural steel shall be cleaned and painted prior to erection as required by the Special Provision "Cleaning and Painting Contact Surface Areas of Existing Steel Structures".
 All structural steel shall be shop painted with the inorganic zinc rich primer per AASHTO M300, Type 1. Cost included with Furnishing and Erecting Structural Steel.

PLAN
Remove and replace bearings at abutments.

BILL OF MATERIAL

ITEM	UNIT	TOTAL
Furnishing and Erecting Structural Steel	Pound	4710
Anchor Bolt 1"φ	Each	96
Elastomeric Bearing Assembly, Type I	Each	12
Elastomeric Bearing Assembly, Type II	Each	12
Jack and Remove Existing Bearings	Each	24

**BEARING REPLACEMENT PLAN AND ELEVATION
FAI RT. 72 OVER FRIENDS CREEK
SN 058-0093 & 0094**

DESIGNED	<i>Angie Bura-Turner</i>
CHECKED	<i>Sital Bhakta</i>
DRAWN	<i>baliva</i>
CHECKED	<i>VHV</i>

OCTOBER 30, 2009
 EXAMINED *A. Cal...*
 PASSED *Ralph E. Adams*
 ENGINEER OF STRUCTURAL SERVICES
 ENGINEER OF BRIDGES AND STRUCTURES



EXPIRES 11-30-2010

SHEET NO. 15	F.A.I. RTE.	SECTION	COUNTY	TOTAL SHEETS	SHEET NO.
	72	66(B,HVB,HB-1)BR	MACON	83	42
17 SHEETS	CONTRACT NO. 74343				
FED. ROAD DIST. NO.		ILLINOIS	FED. AID PROJECT		

STATE OF ILLINOIS
DEPARTMENT OF TRANSPORTATION

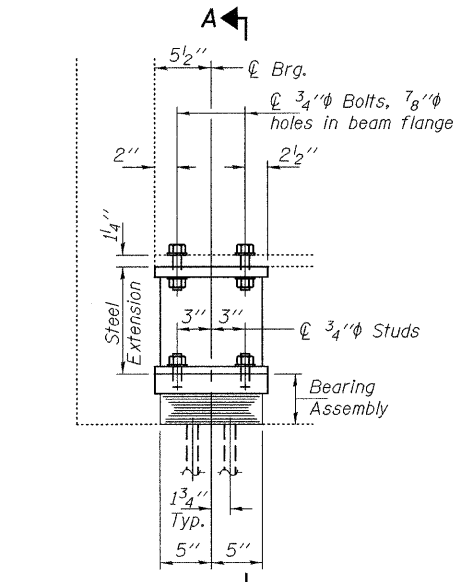

ELEVATION AT W. ABUTMENT

TYPE I ELASTOMERIC EXP. BRG.

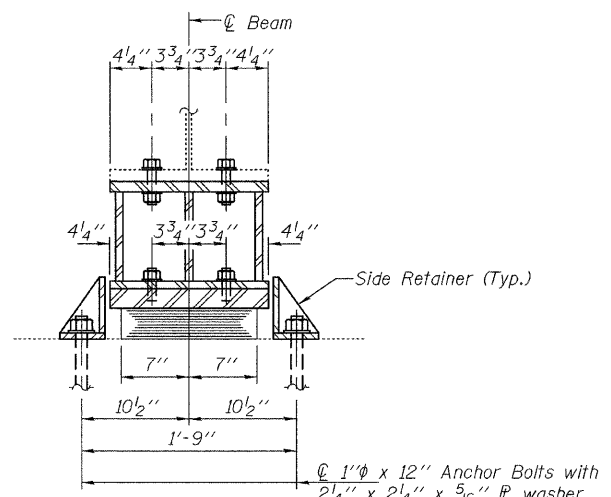

SECTION A-A

BEAM REACTIONS

R _D	(K)	57.2
R _L	(K)	42.4
Imp.	(K)	8.9
R (Total)	(K)	108.5

Notes:
Diaphragm removal and reinstallation may be required to facilitate drilling holes. Cost included with Furnishing and Erecting Structural Steel.
New steel extensions, shim plates and connection bolts are included with Furnishing and Erecting Structural Steel.
Prior to ordering any material, the Contractor shall verify in the field all bearing height and shim thickness dimensions. Min. jack capacity = 65 Tons.
Anchor bolts shall be ASTM F1554 all-thread (or an Engineer-approved alternate material) of the grade(s) and diameter(s) specified. ASTM A307 Grade C anchor bolts may be used in lieu of ASTM F1554 Grade 36 (F_y=36ksi). The corresponding specified grade of AASHTO M314 anchor bolts may be used in lieu of ASTM F1554.
Drilled and set anchor bolts shall be installed according to Article 521.06 of the Standard Specifications.
Side retainers shall be included in the cost of Elastomeric Bearing Assembly, Type I.

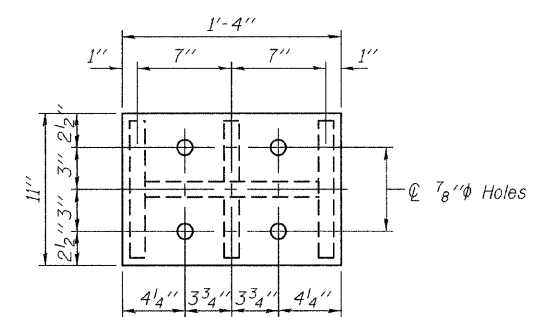

PLAN TOP AND BOTTOM PLATE

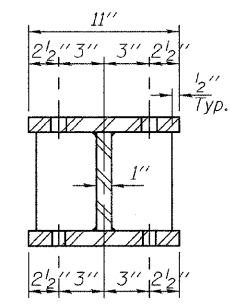

SECTION B-B

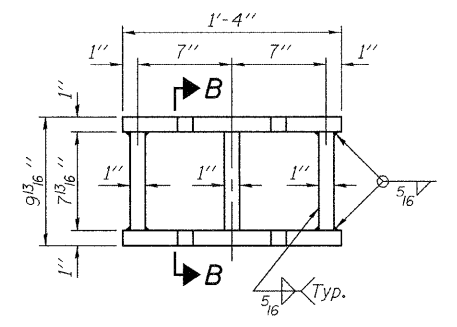

STEEL EXTENSION DETAIL

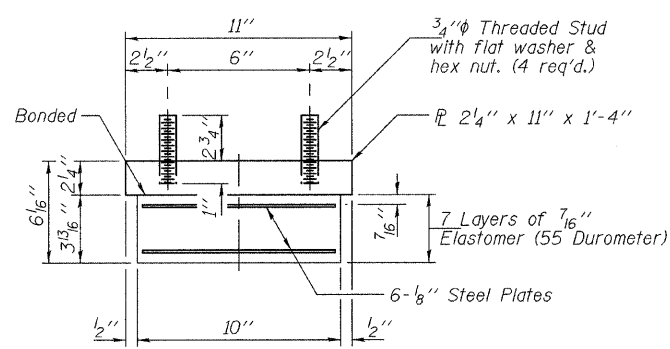

BEARING ASSEMBLY

Note:
Shim plates shall not be placed under Bearing Assembly.

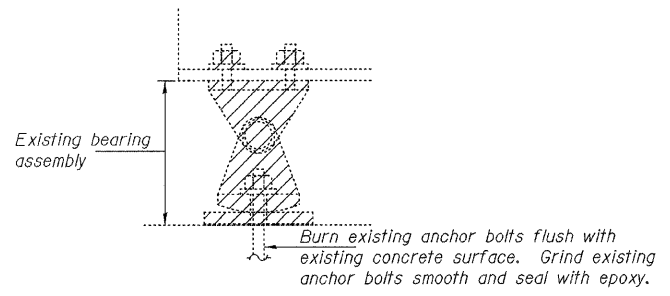

EXISTING BEARING REMOVAL DETAIL

Cost included with Jack and Remove Existing Bearings.

BILL OF MATERIAL

Item	Unit	Total
Elastomeric Bearing Assembly Type I	Each	12
Jack and Remove Existing Bearings	Each	12
Furnishing and Erecting Structural Steel	Pound	2380
Anchor Bolt 1"φ	Each	48

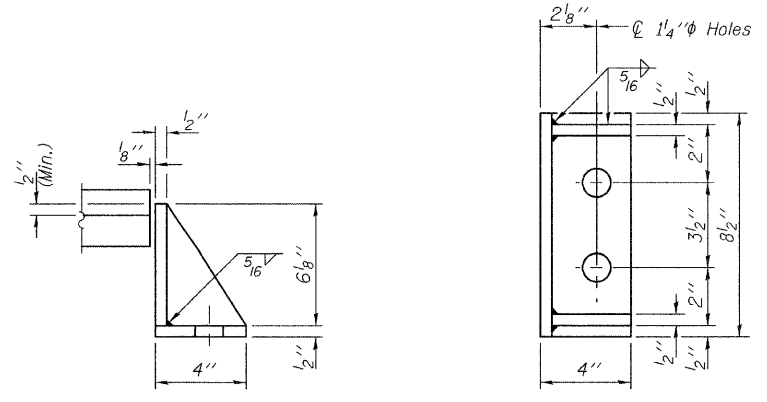

SIDE RETAINER

Equivalent rolled angle with stiffeners will be allowed in lieu of welded plates.

DESIGNED	AJB
CHECKED	SJB
DRAWN	baliva
CHECKED	AJB SJB

OCTOBER 30, 2009
EXAMINED *Carl P. ...*
PASSED *Ralph E. Anderson*

TYI/REPS 11-01-2006

WEST ABUTMENT BEARING
REPLACEMENT DETAILS
FAI RT. 72 OVER FRIENDS CREEK
SN 058-0093 & 0094

SHEET NO. 16 17 SHEETS	F.A.I. RTE.	SECTION	COUNTY	TOTAL SHEETS	SHEET NO.
	72	66(B,HVB,HB-1)BR	MACON	83	43
CONTRACT NO. 74343					
FED. ROAD DIST. NO. ILLINOIS FED. AID PROJECT					

STATE OF ILLINOIS
DEPARTMENT OF TRANSPORTATION

BEAM REACTIONS

R _ℓ	(K)	55.4
R _r	(K)	42.3
Imp.	(K)	8.9
R (Total)	(K)	106.6

Notes:
Diaphragm removal and reinstallation may be required to facilitate drilling holes. Cost included with Furnishing and Erecting Structural Steel.
New steel extensions, shim plates and connection bolts are included with Furnishing and Erecting Structural Steel.
Prior to ordering any material, the Contractor shall verify in the field all bearing height and shim thickness dimensions. Min. jack capacity = 65 Tons.
Anchor bolts shall be ASTM F1554 all-thread (or an Engineer-approved alternate material) of the grade(s) and diameter(s) specified. ASTM A307 Grade C anchor bolts may be used in lieu of ASTM F1554 Grade 36 (F_y=36ksi). The corresponding specified grade of AASHTO M314 anchor bolts may be used in lieu of ASTM F1554.
Anchor bolts for Type II bearings shall be placed in holes drilled through the bottom bearing plate after members are in place. Side retainers shall be placed after bolts are installed.
Drilled and set anchor bolts shall be installed according to Article 521.06 of the Standard Specifications.
Side retainers shall be included in the cost of Elastomeric Bearing Assembly, Type II.
The 1/8" PTFE sheet shall be bonded directly to the top steel plate with a two-component, medium viscosity epoxy resin, conforming to the requirements of the Federal Specification MMM-A-134, Type I. The bond agent shall be applied on the full area of the contact surfaces.
Bonding of 1/8" PTFE sheet during vulcanizing process will be permitted provided the process and method of adjusting assembly height is approved by the Engineer.

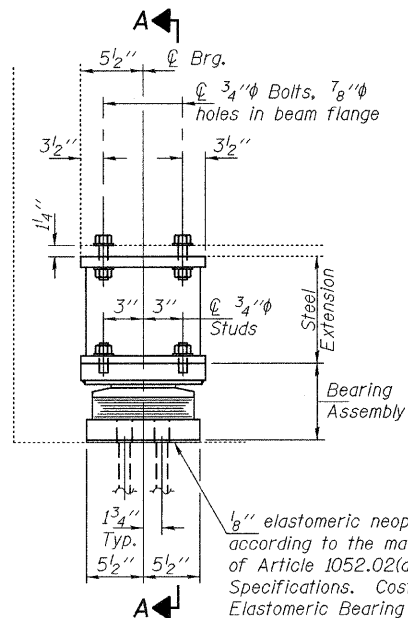

ELEVATION AT E. ABUTMENT

TYPE II TFE ELASTOMERIC EXP. BRG.

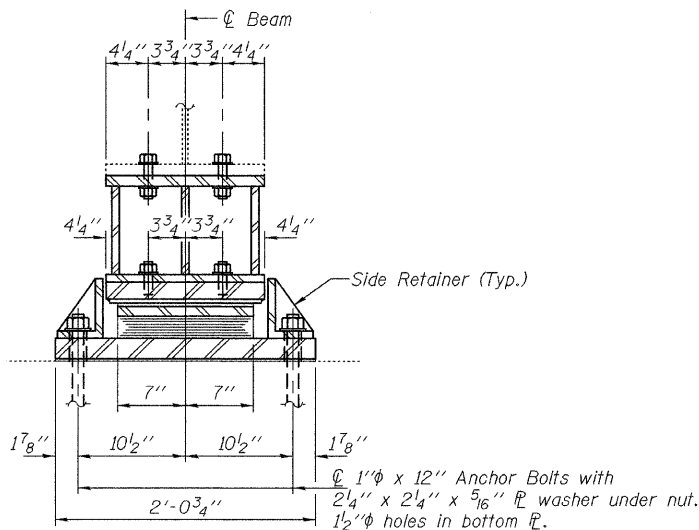

SECTION A-A

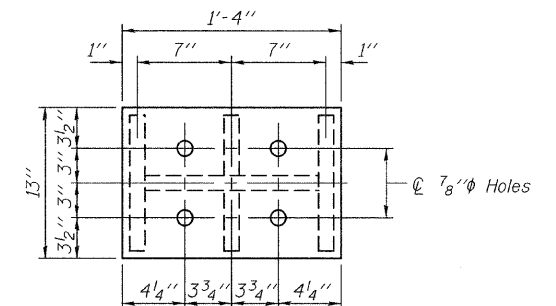

PLAN TOP AND BOTTOM PLATE

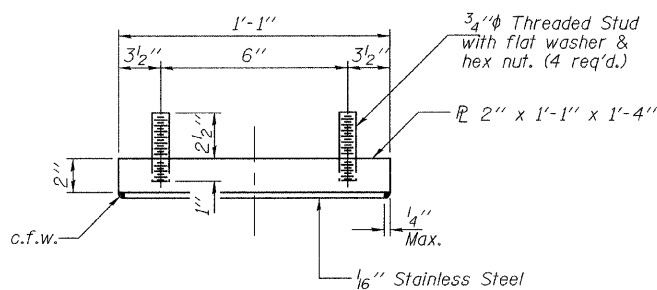

TOP BEARING ASSEMBLY

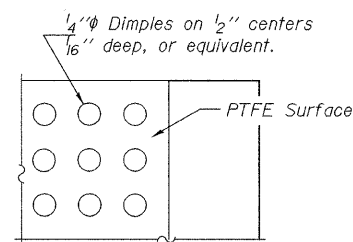

PLAN-PTFE SURFACE

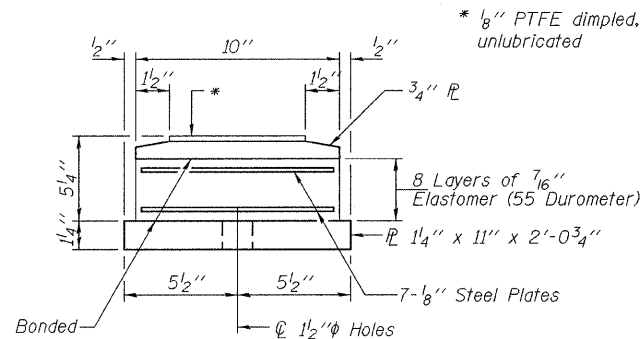

BOTTOM BEARING ASSEMBLY

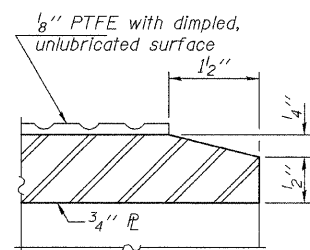

SECTION THRU TFE

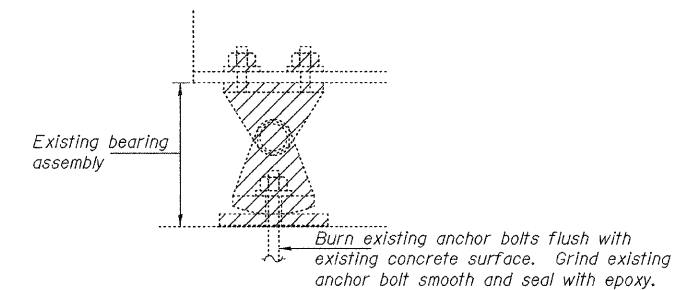

EXISTING BEARING REMOVAL DETAIL

Cost included with Jack and Remove Existing Bearings.

BILL OF MATERIAL

Item	Unit	Total
Elastomeric Bearing Assembly Type II	Each	12
Jack and Remove Existing Bearings	Each	12
Furnishing and Erecting Structural Steel	Pound	2330
Anchor Bolt 1" ℓ	Each	48

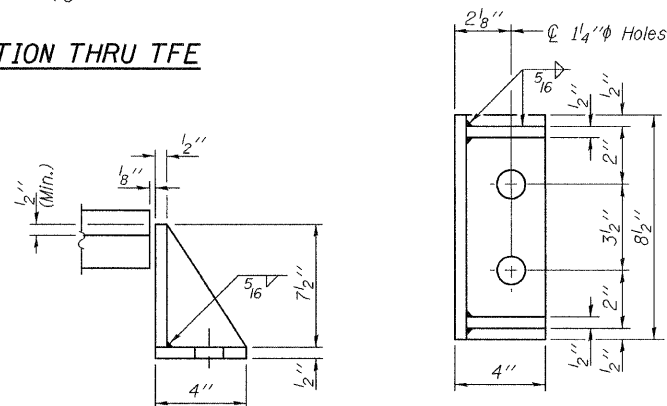

SIDE RETAINER

Equivalent rolled angle with stiffeners will be allowed in lieu of welded plates.

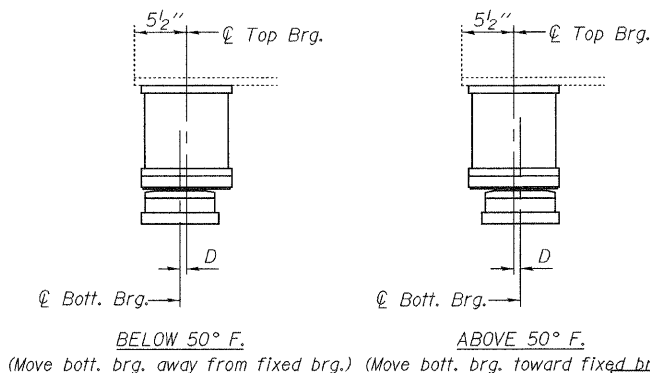

SETTING ANCHOR BOLTS AT EXP. BRG.

D = 1/8" per each 100' of expansion for every 15° temp. change from the normal temp. of 50°F.

DESIGNED	AJB
CHECKED	SJB
DRAWN	baliva
CHECKED	AJB SJB

OCTOBER 30, 2009
EXAMINED *A. Carl Proyer*
ENGINEER OF STRUCTURAL SERVICES
PASSED *Ralph E. Anderson*
ENGINEER OF BRIDGES AND STRUCTURES

TYII/REPS 11-01-2006

SHEET NO. 17 17 SHEETS	F.A.I. RTE. 72	SECTION 66(B,HVB,HB-1)BR	COUNTY MACON	TOTAL SHEETS 83	SHEET NO. 44
	CONTRACT NO. 74343				
FED. ROAD DIST. NO.		ILLINOIS FED. AID PROJECT			

EAST ABUTMENT BEARING
REPLACEMENT DETAILS
FAI RT. 72 OVER FRIENDS CREEK
SN 058-0093 & 0094

GENERAL NOTES

Reinforcement bars shall conform to the requirements of ASTM A 706 Br 60 (IL Modified). See Special Provisions.

Reinforcement bars designated (E) shall be epoxy coated.

Plan dimensions and details relative to existing plans are subject to routine variations. The Contractor shall field verify existing dimensions and details affecting new construction and make necessary approved adjustments prior to construction or ordering of materials. Such variations shall not be cause for additional compensations for a change in scope of the work; however, the Contractor will be paid for the quantity actually furnished based upon the unit price bid for the work.

Existing reinforcement bars extending into the removal area shall be cleaned, straightened and incorporated into the new construction. Any reinforcement bars that are damaged during concrete removal operations shall be repaired or replaced using an approved bar splicer or anchorage system. Cost included in concrete removal.

Joint openings shall be adjusted according to Article 520.04 of the Standard Specifications when the deck is poured at an ambient temperature other than 50°F.

Prior to pouring the new concrete deck, all heavy or loose rust, loose mill scale, and other loose or potentially detrimental foreign material shall be removed from the surfaces in contact with concrete. Tightly adhered paint may remain unless otherwise noted. Removal shall be accomplished by methods that will not damage the steel and the cost will be included in the pay item covering removal of the existing concrete.

Removal and replacement of the end handrail sections and support posts at both abutments of both structures will be necessary for construction of the expansion joints. The existing handrail sections and support posts shall be reused. New bolts, shim plates, and post support anchor assemblies as detailed in the plans are to be provided and installed for the replacement of the handrail and supports. This work and all materials shall be included in the contract unit price for Concrete Superstructure.

Areas of deck repairs shown are estimated. The Engineer shall show actual locations of deck repairs on as-built plans.

The existing waterproofing membrane system is not known to contain asbestos.

Construction of a Bridge Approach Wingwall Improvement at locations specified on the plans will be necessary prior to erecting the new guardrail. The end of the existing aluminum railing shall be cut as shown in the details and removed prior to placement of the new concrete. This work and all materials shall be included in the contract unit price for Concrete Superstructure.

Removal and reinstallation of the existing name plates on both structures will necessary for construction of the expansion joints. This work and all materials shall be included in the contract unit price for Relocating Name Plates.

TOTAL BILL OF MATERIALS

SN 058-0095 (EB)

ITEM DESCRIPTION	UNIT	QUANTITY
Concrete Removal	Cu. Yd.	49.2
Concrete Superstructure	Cu. Yd.	110.9
Reinforcement Bars, Epoxy Coated	Pound	25030
Bar Splicers	Each	72
Elastomeric Bearing Assembly Type II	Each	12
Furnishing and Erecting Structural Steel	Pound	1710
Jack and Remove Existing Bearings	Each	12
Hot Mix Asphalt Removal (Deck)	Sq. Yd.	1506
Bridge Deck Hydro-Scarification, 1/2"	Sq. Yd.	1506
Bridge Deck Microsilica Concrete Overlay, 2 1/4"	Sq. Yd.	1506
Bridge Deck Grooving	Sq. Yd.	1506
Protective Coat	Sq. Yd.	1506
Deck Slab Repair (Full Depth Type I)	Sq. Yd.	10
Deck Slab Repair (Full Depth Type II)	Sq. Yd.	26
Floor Drains	Each	40
Preformed Joint Strip Seal	Foot	192
Structural Repair of Concrete <5"	Sq. Ft.	266
Relocating Name Plates	Each	1
Plug Existing Deck Drains	Each	46
Anchor Bolts 1" Ø	Each	24
Protective Shield	Sq. Yd.	1124
Concrete Structures	Cu. Yd.	19.3
Porous Granular Embankment (Special)	Cu. Yd.	152
Geocomposite Wall Drain	Sq. Yd.	70
Pipe Underdrain For Structures, 4"	Feet	72
Temporary Soil Retention System	Sq. Ft.	70
Structure Excavation	Cu. Yd.	152

TOTAL BILL OF MATERIALS

SN 058-0096 (WB)

ITEM DESCRIPTION	UNIT	QUANTITY
Concrete Removal	Cu. Yd.	53.3
Concrete Superstructure	Cu. Yd.	59.4
Reinforcement Bars, Epoxy Coated	Pound	7040
Bar Splicers	Each	72
Elastomeric Bearing Assembly Type II	Each	12
Furnishing and Erecting Structural Steel	Pound	1710
Jack and Remove Existing Bearings	Each	12
Hot-Mix Asphalt Removal (Deck)	Sq. Yd.	1506
Bridge Deck Hydro-Scarification, 1/2"	Sq. Yd.	1506
Bridge Deck Microsilica Concrete Overlay, 2 1/4"	Sq. Yd.	1506
Bridge Deck Grooving	Sq. Yd.	1506
Protective Coat	Sq. Yd.	1506
Deck Slab Repair (Full Depth Type I)	Sq. Yd.	10
Deck Slab Repair (Full Depth Type II)	Sq. Yd.	32
Floor Drains	Each	40
Preformed Joint Strip Seal	Foot	192
Structural Repair of Concrete <5"	Sq. Ft.	193
Relocating Name Plates	Each	1
Plug Existing Deck Drains	Each	46
Anchor Bolts, 1" Ø	Each	24
Protective Shield	Sq. Yd.	1124

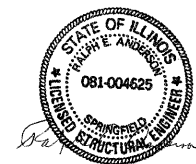

Expires Nov. 30, 2010

FILE NAME =	USER NAME = #USER#	DESIGNED -	REVISED -	STATE OF ILLINOIS DEPARTMENT OF TRANSPORTATION	BRIDGE GENERAL NOTES & BILL OF MATERIALS SN 058-0095 (EB) & SN 058-0096 (WB)	F.A.I. RTE.	SECTION	COUNTY	TOTAL SHEETS	SHEET NO.	
#FILEL#		DRAWN -	REVISED -			72	66(B,HVB,HB-1)BR	MACON	83	45	
	PLOT SCALE = #SCALE#	CHECKED -	REVISED -			SCALE: N/A	SHEET NO. 1 OF 21 SHEETS	STA.	TO STA.	CONTRACT NO. 74343	
	PLOT DATE = #DATE#	DATE -	REVISED -					FED. ROAD DIST. NO. ILLINOIS FED. AID PROJECT			

The existing 3 span steel multi-beam structures were constructed in 1975 as section 58-66HVB. SN 058-0095 carries FAI-72 eastbound and SN 085-0096 carries FAI-72 westbound. The proposed project consists of new expansion joints, partial and full depth deck patching, remove and replace bearings at abutments, new microsilica wearing surface, new deck drains and structural repair of concrete. A new approach pavement will be constructed on the east end of SN 058-0095 (EB).

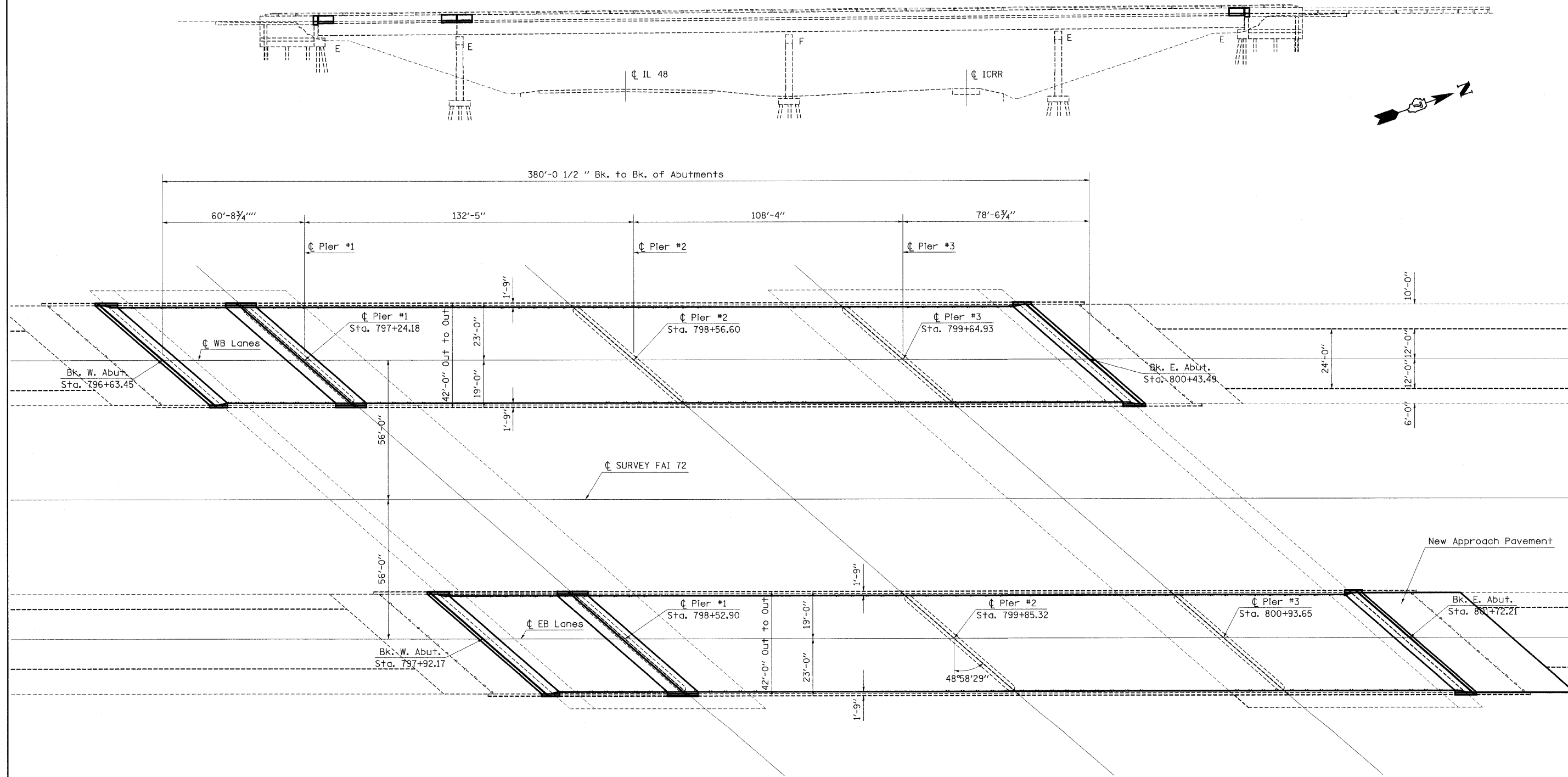

FILE NAME = c:\pwwork\pwwid\SWARTZRW\dms37779\koenbridge.dgn	USER NAME = swartzrw	DESIGNED -	REVISED -	STATE OF ILLINOIS DEPARTMENT OF TRANSPORTATION	GENERAL PLAN & ELEVATION SN 058-0095 (EB) & SN 058-0096 (WB)			F.A.I. RTE. 72	SECTION 66(B,HVB,HB-1)BR	COUNTY MACON	TOTAL SHEETS 83	SHEET NO. 46
PLOT SCALE = 20,0000' / IN.	PLOT DATE = 9/28/2009	DRAWN -	REVISED -		SCALE: N/A	SHEET NO. 2 OF 21 SHEETS	STA.	TO STA.	CONTRACT NO. 74343			
		CHECKED -	REVISED -		FED. ROAD DIST. NO. ILLINOIS FED. AID PROJECT							
		DATE -	REVISED -									

Note: Trim existing long. reinf. to accommodate new joint opening (typ.)

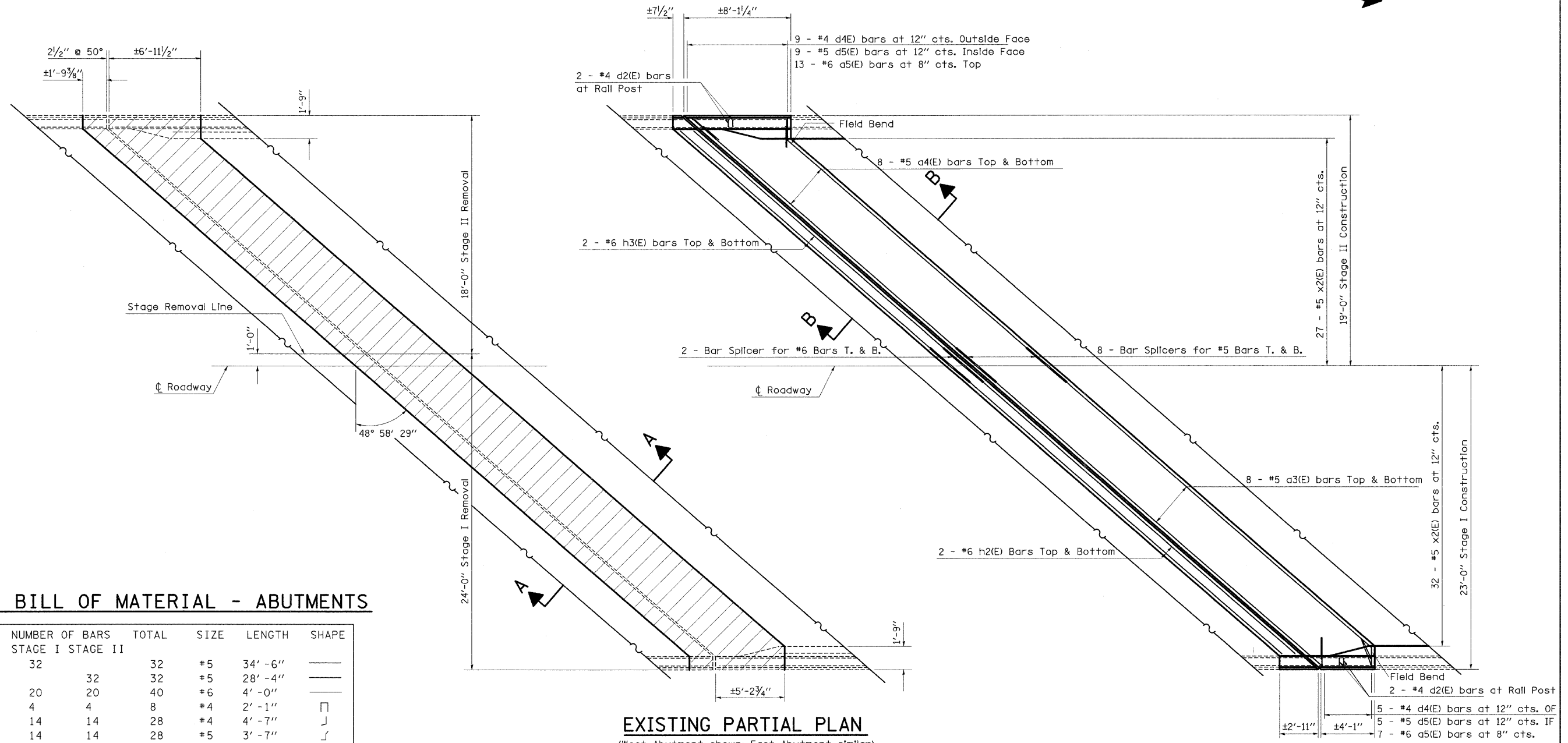
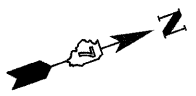

TOTAL BILL OF MATERIAL - ABUTMENTS

BAR	NUMBER OF BARS		TOTAL	SIZE	LENGTH	SHAPE
	STAGE I	STAGE II				
a3(E)	32		32	#5	34' -6"	—
a4(E)		32	32	#5	28' -4"	—
a5(E)	20	20	40	#6	4' -0"	—
d2(E)	4	4	8	#4	2' -1"	□
d4(E)	14	14	28	#4	4' -7"	┌┐
d5(E)	14	14	28	#5	3' -7"	┌┐
h2(E)	4	4	8	#6	33' -0"	—
h3(E)	4	4	8	#6	26' -10"	—
x2(E)	64	54	118	#5	4' -6"	┌┐
CONCRETE REMOVAL					CU. YD.	29.9
REINFORCEMENT BARS (EPOXY COATED)					POUND	3820
CONCRETE SUPERSTRUCTURE					CU. YD.	33.1

REINFORCEMENT BARS DESIGNATED (E) SHALL BE EPOXY COATED

EXISTING PARTIAL PLAN

(West Abutment shown; East Abutment similar)

PROPOSED PARTIAL PLAN

(West Abutment shown; East Abutment similar)

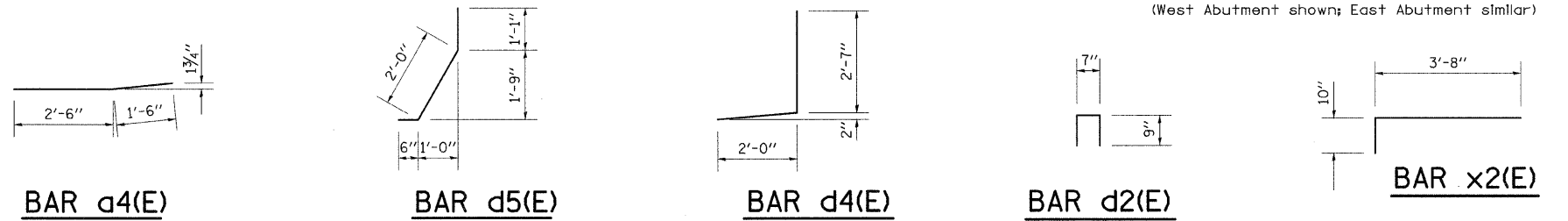

Note: Trim existing long. reinf. to accommodate new joint opening (typ.)

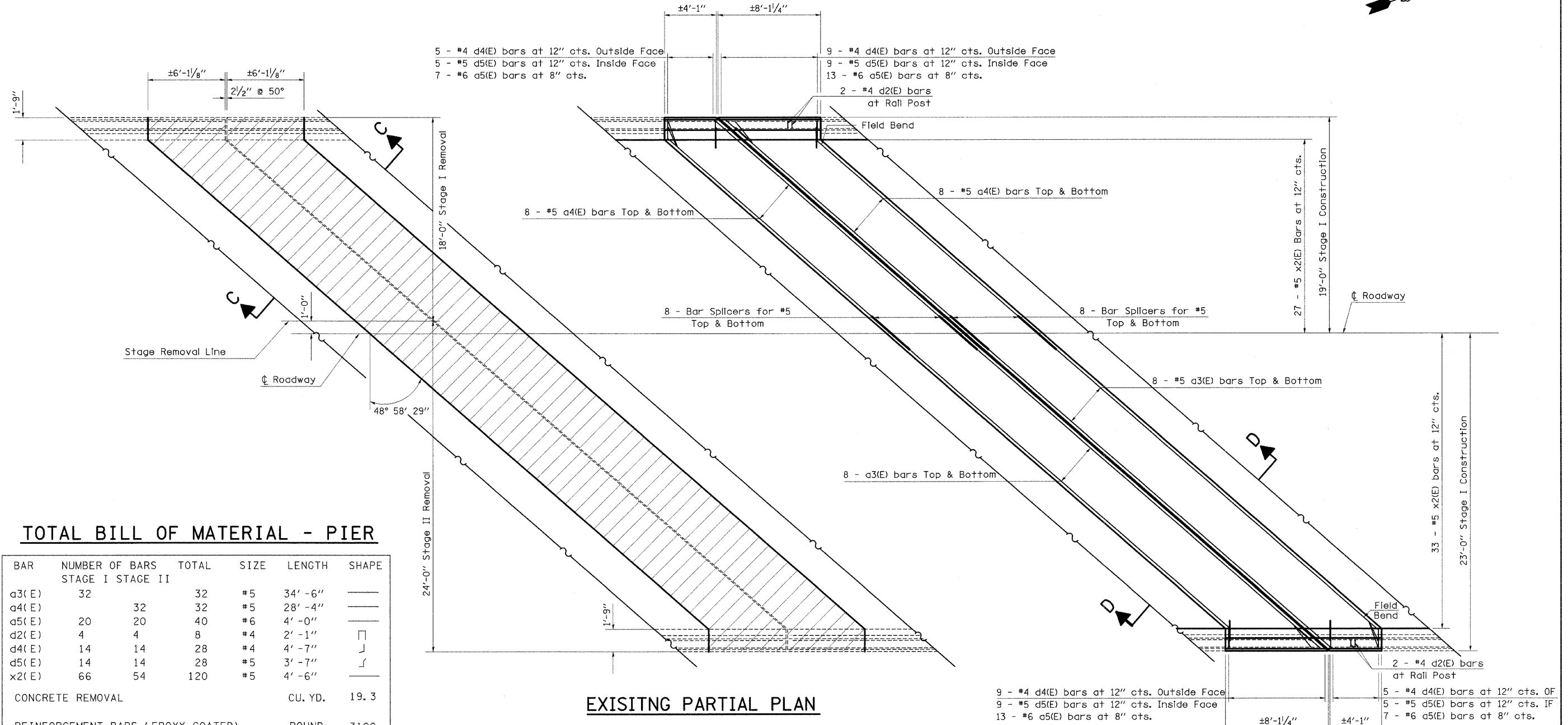

TOTAL BILL OF MATERIAL - PIER

BAR	NUMBER OF BARS		TOTAL	SIZE	LENGTH	SHAPE
	STAGE I	STAGE II				
a3(E)	32		32	#5	34' - 6"	—
a4(E)		32	32	#5	28' - 4"	—
a5(E)	20	20	40	#6	4' - 0"	—
d2(E)	4	4	8	#4	2' - 1"	⌊
d4(E)	14	14	28	#4	4' - 7"	┌
d5(E)	14	14	28	#5	3' - 7"	┌
x2(E)	66	54	120	#5	4' - 6"	—
CONCRETE REMOVAL			CU. YD.	19.3		
REINFORCEMENT BARS (EPOXY COATED)			POUND	3100		
CONCRETE SUPERSTRUCTURE			CU. YD.	21.9		

REINFORCEMENT BARS DESIGNATED (E) SHALL BE EPOXY COATED

EXISTING PARTIAL PLAN

PROPOSED PARTIAL PLAN

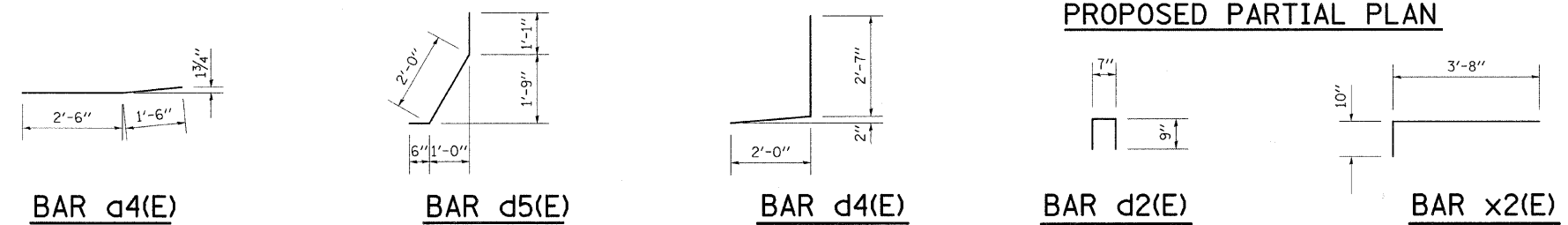

Note: Trim existing long. reinf. to accommodate new joint opening (typ.)

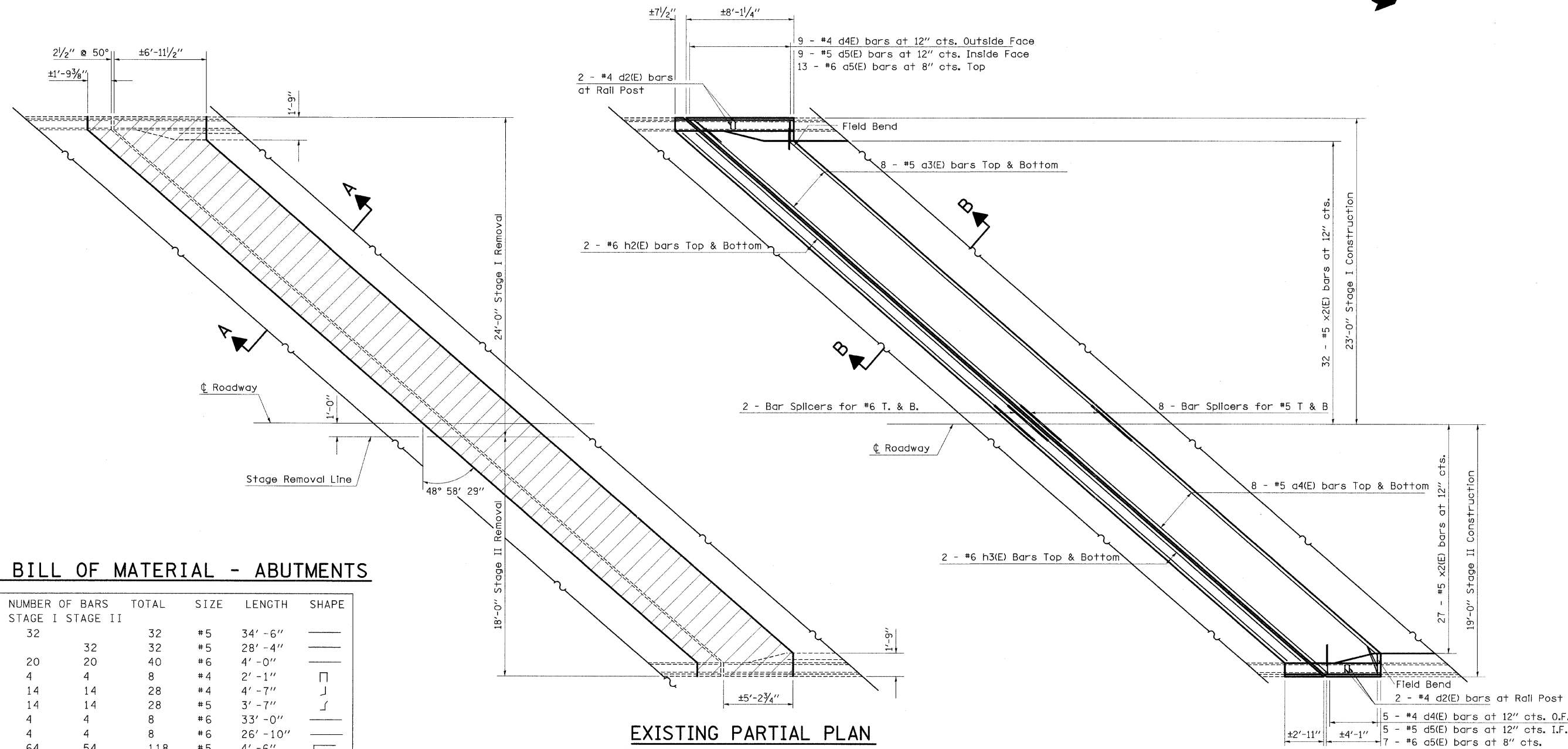

TOTAL BILL OF MATERIAL - ABUTMENTS

BAR	NUMBER OF BARS		TOTAL	SIZE	LENGTH	SHAPE
	STAGE I	STAGE II				
a3(E)	32		32	#5	34' - 6"	—
a4(E)		32	32	#5	28' - 4"	—
a5(E)	20	20	40	#6	4' - 0"	—
d2(E)	4	4	8	#4	2' - 1"	□
d4(E)	14	14	28	#4	4' - 7"	J
d5(E)	14	14	28	#5	3' - 7"	J
h2(E)	4	4	8	#6	33' - 0"	—
h3(E)	4	4	8	#6	26' - 10"	—
x2(E)	64	54	118	#5	4' - 6"	┌
CONCRETE REMOVAL				CU. YD.	32.6	
REINFORCEMENT BARS (EPOXY COATED)				POUND	3820	
CONCRETE SUPERSTRUCTURE				CU. YD.	35.9	

REINFORCEMENT BARS DESIGNATED (E) SHALL BE EPOXY COATED

EXISTING PARTIAL PLAN
(West Abutment shown; East Abutment similar)

PROPOSED PARTIAL PLAN
(West Abutment shown; East Abutment similar)

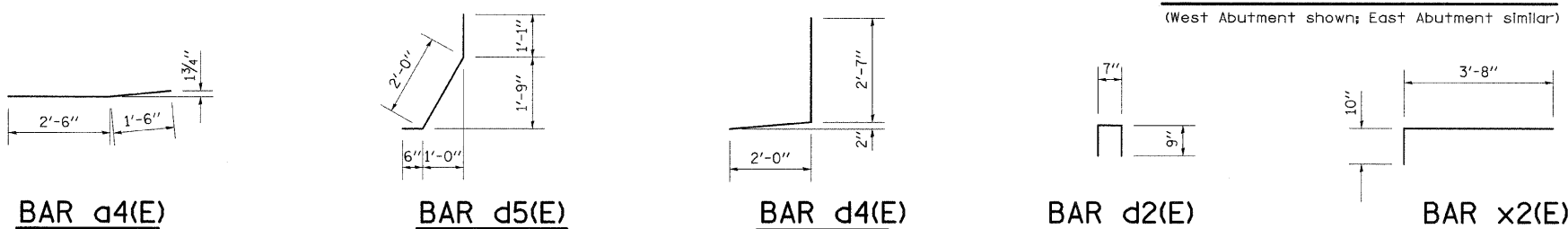

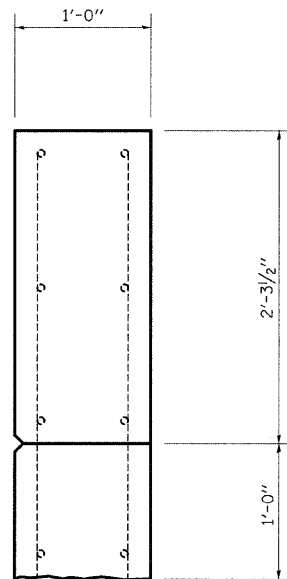

WINGWALL DETAIL

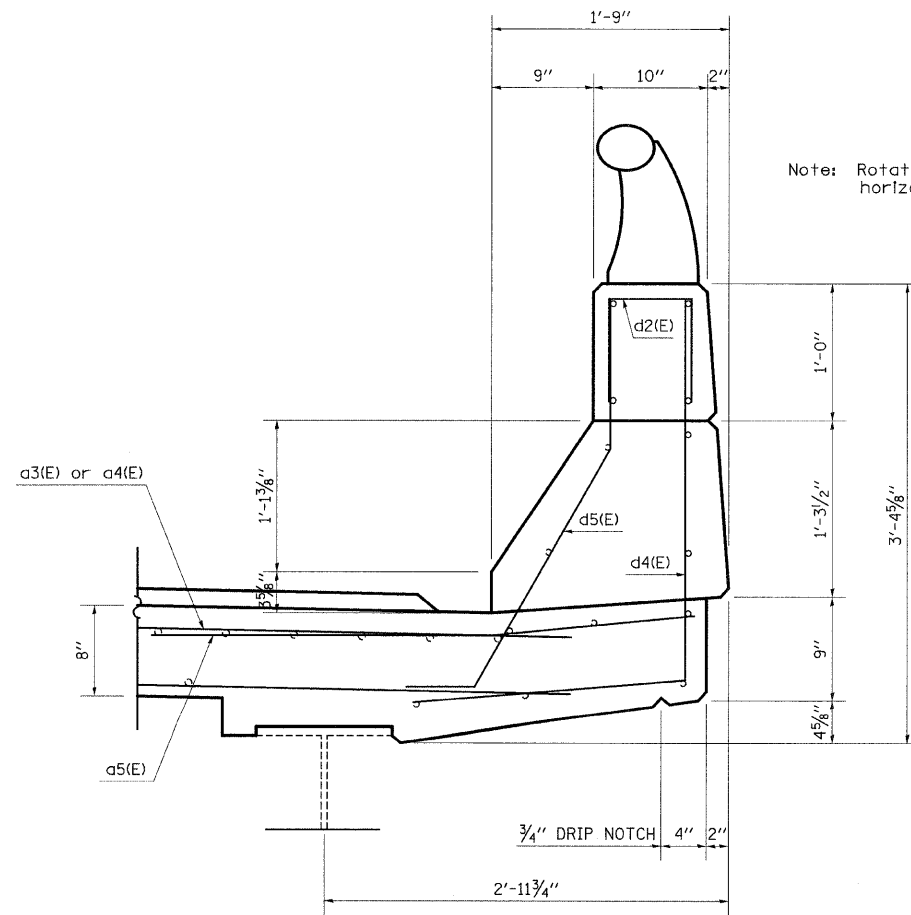

SECTION THRU PARAPET

- 058-0096(WB) East Abut. 15"
- 058-0096(WB) West Abut. 14"
- 058-0095(EB) West Abut. 13"
- 058-0095(EB) East Abut. 12"

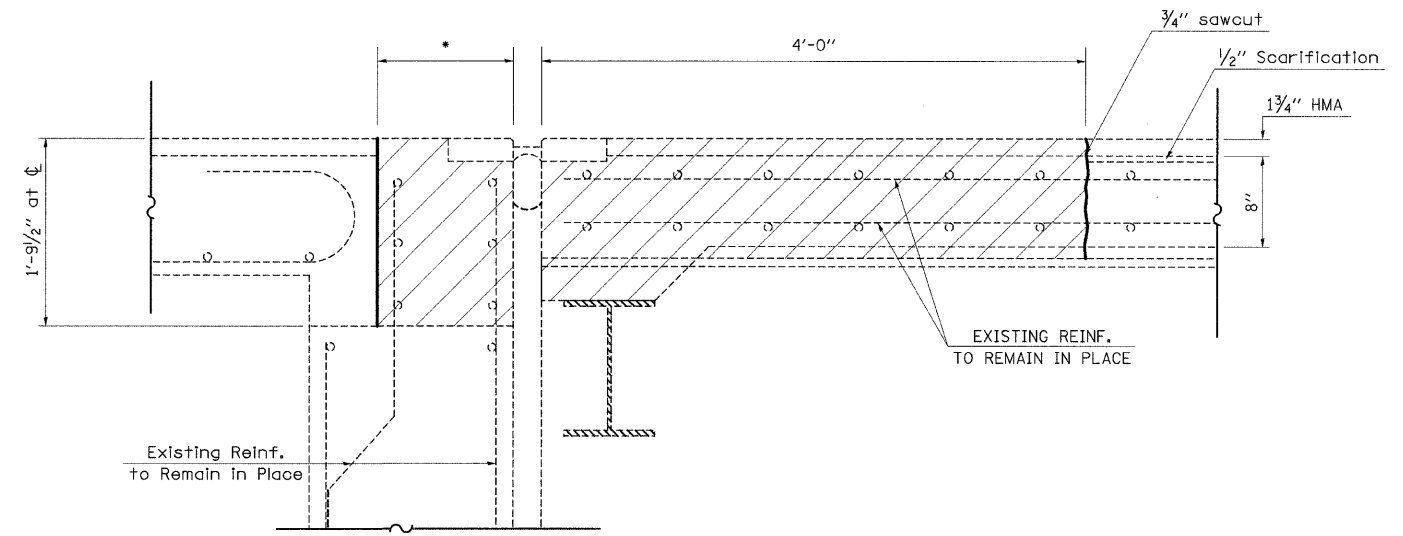

SECTION A-A

(Dimensions at RT L's to end of deck)

- Existing Reinforcement
- Proposed Reinforcement

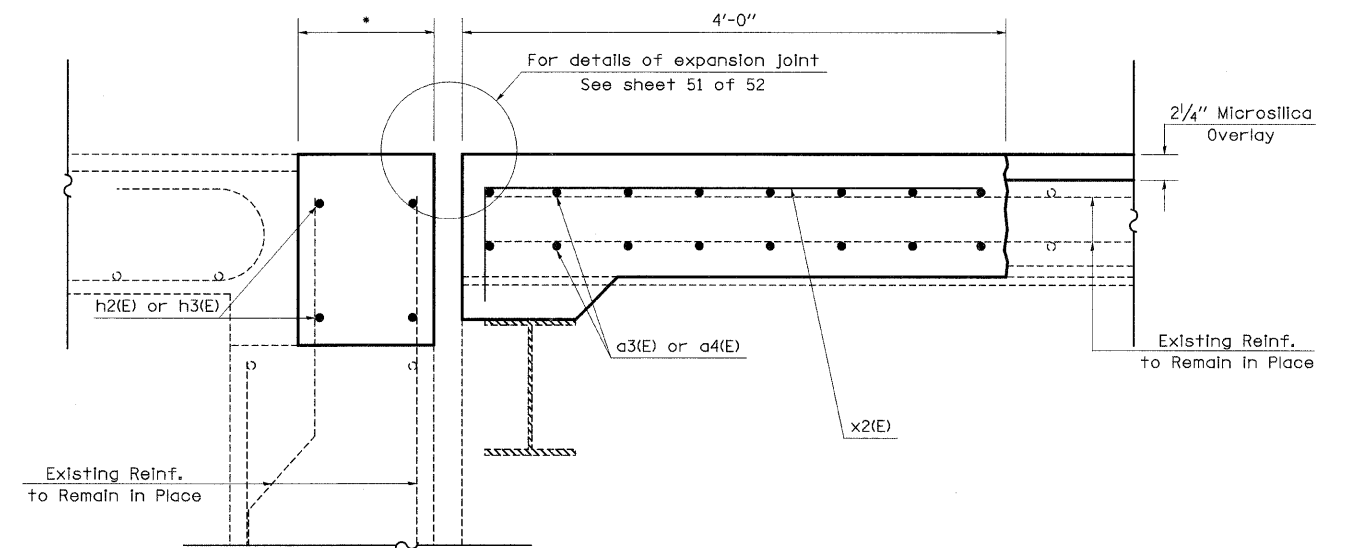

SECTION B-B

(Dimensions at RT L's to end of deck)

FILE NAME =	USER NAME = swartzrw	DESIGNED -	REVISED -
c:\pwork\pwwid\SWARTZRW\dms37779\k	enbridge.dgn	DRAWN -	REVISED -
	PLOT SCALE = 20.0000' / IN.	CHECKED -	REVISED -
	PLOT DATE = 9/28/2009	DATE -	REVISED -

**STATE OF ILLINOIS
DEPARTMENT OF TRANSPORTATION**

**ABUTMENT EXPANSION JOINT REPLACEMENT DETAILS
SN 058-0095 (EB) & SN 058-0096 (WB)**

SCALE: N/A SHEET NO. 7 OF 21 SHEETS STA. TO STA.

F.A.I. RTE.	SECTION	COUNTY	TOTAL SHEETS	SHEET NO.
72	66(B,HVB,HB-1)BR	MACON	83	51
CONTRACT NO. 74343				
FED. ROAD DIST. NO. ILLINOIS FED. AID PROJECT				

Note: Rotate d4(E) and d5(E) bars in parapet to fit horizontal legs in concrete pour.

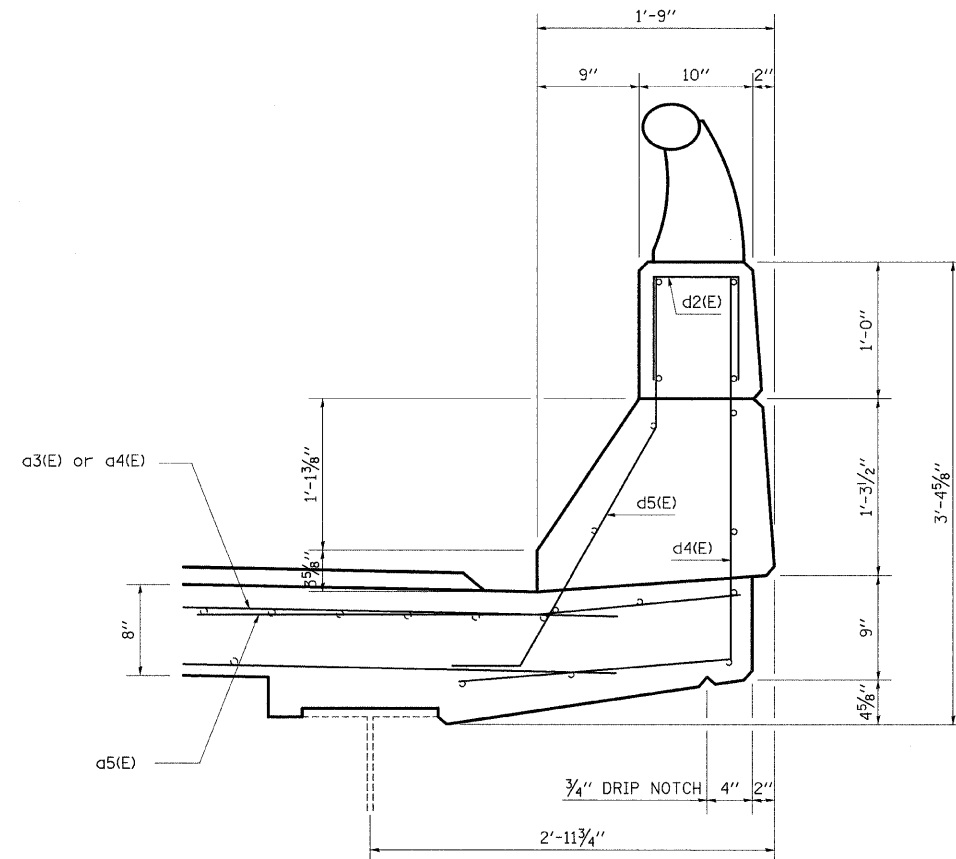

SECTION THRU PARAPET

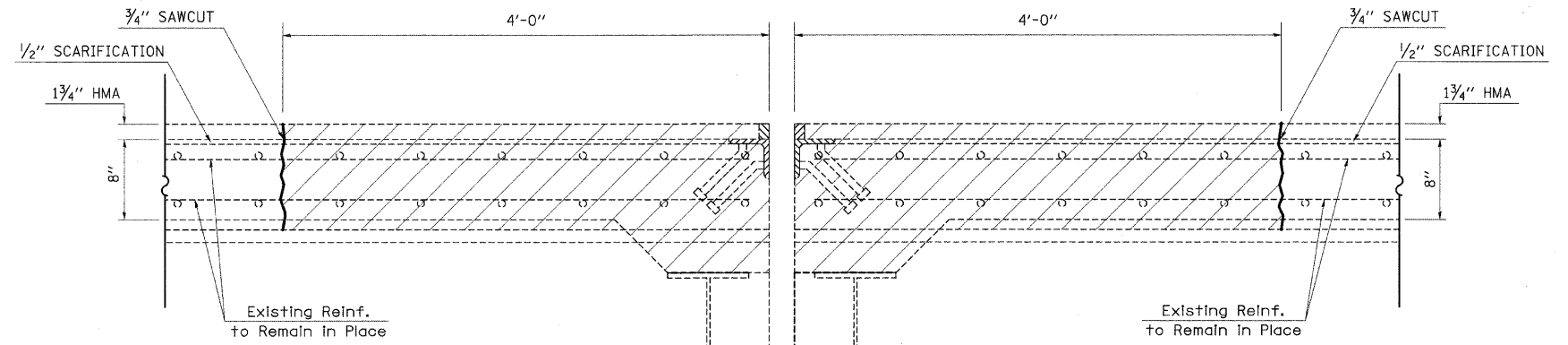

SECTION C-C
(Dimensions at RT L's to end of deck)

○ Existing Reinforcement
● Proposed Reinforcement

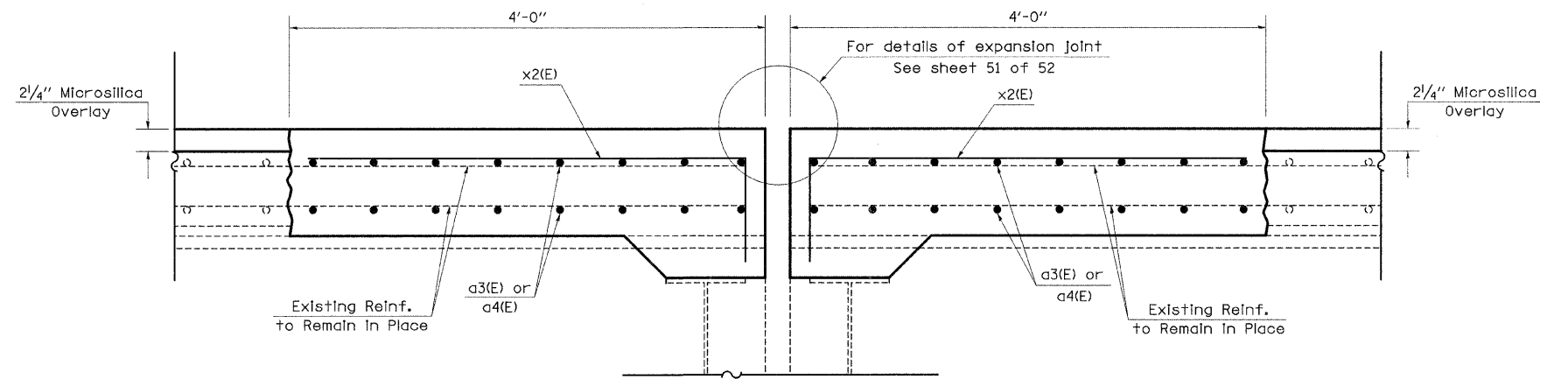

SECTION D-D
(Dimensions at RT L's to end of deck)

FILE NAME = c:\pw\work\PWIDOT\SWARTZR\dm37779\k...enbridge.dgn	USER NAME = swartzr	DESIGNED -	REVISED -
		DRAWN -	REVISED -
	PLOT SCALE = 20,0000 ' / IN.	CHECKED -	REVISED -
	PLOT DATE = 9/28/2009	DATE -	REVISED -

STATE OF ILLINOIS
DEPARTMENT OF TRANSPORTATION

HINGE EXPANSION JOINT REPLACEMENT DETAILS
SN 058-0095 (EB) & SN 058-0096 (WB)

SCALE: N/A SHEET NO. 8 OF 21 SHEETS STA. TO STA.

F.A.I. RTE.	SECTION	COUNTY	TOTAL SHEETS	SHEET NO.
72	66(B,HVB,HB-1)BR	MACON	83	52
CONTRACT NO. 74343				
FED. ROAD DIST. NO. ILLINOIS FED. AID PROJECT				

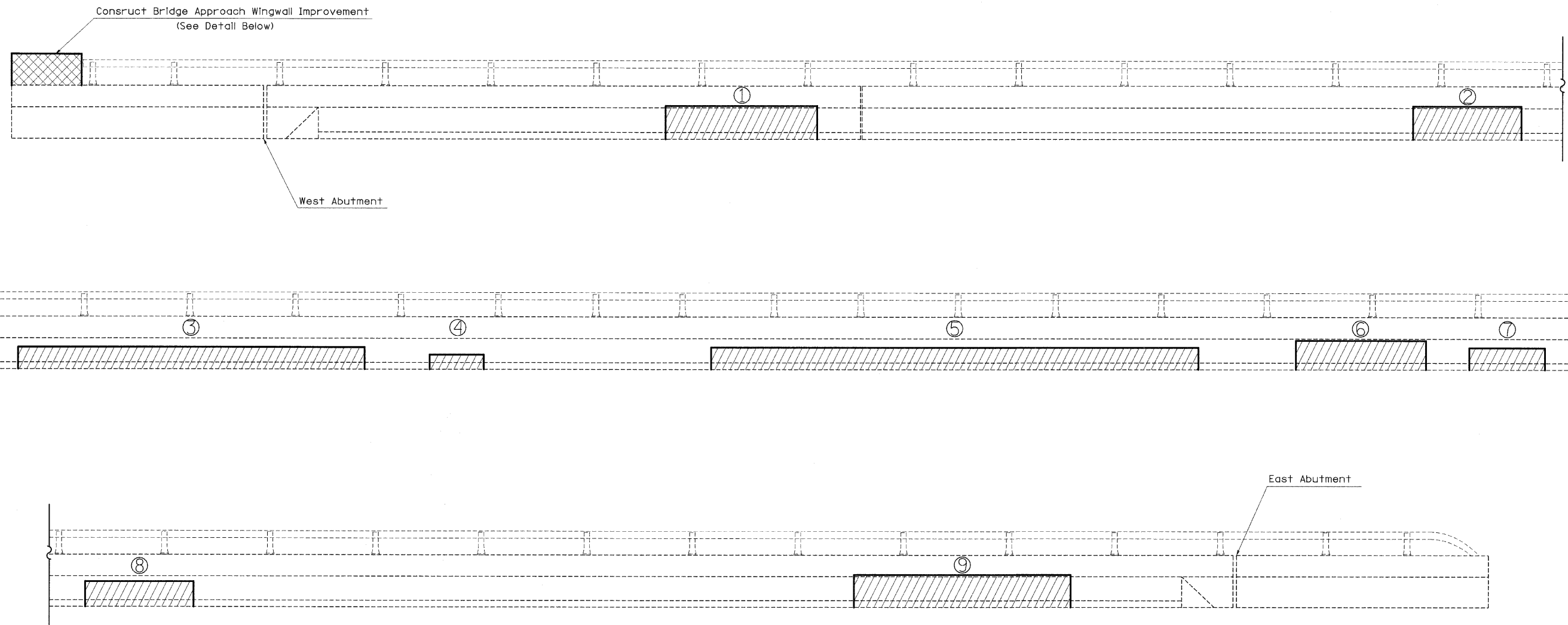

NORTH PARAPET

Looking North

BILL OF MATERIAL

BAR	NUMBER OF BARS	SIZE	LENGTH	SHAPE	REINFORCEMENT BARS (EPOXY COATED)	CONCRETE SUPERSTRUCTURE
d8(E)	5	#5	2' - 1"	U	120	0.3
s(E)	9	#5	3' - 6"	□		
h7(E)	4	#5	7' - 8"	U		
			POUND			
			CU YD			

STRUCTURAL REPAIR

Cost Included In Structural Repair of Concrete (Depth <5")

PATCH NUMBER	STATION	AREA SQ FT
1	798+17	21.0
2	798+84	15.0
3	799+11	32.0
4	799+35	3.3
5	799+81	45.0
6	800+19	16.0
7	800+32	7.0
8	800+47	11.7
9	801+23	30.0
Total		181.0

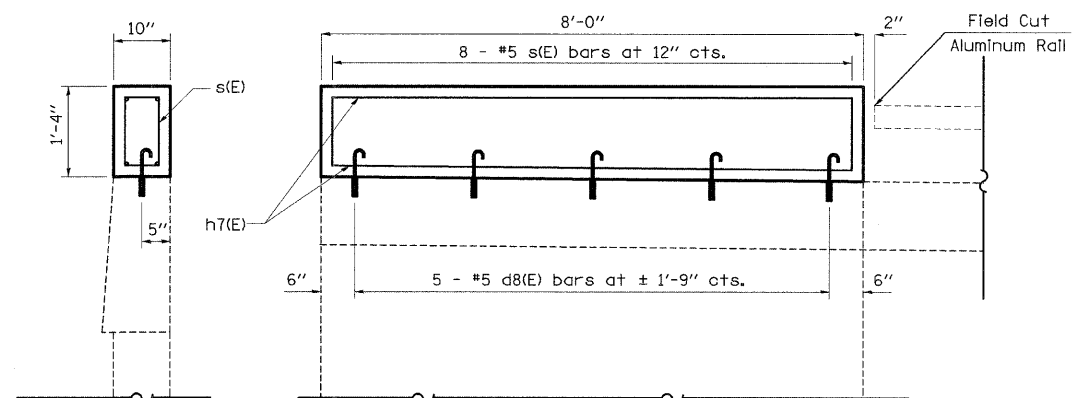

* Epoxy Grouted Bars In accordance with Art. 584 of the Standard Specs.

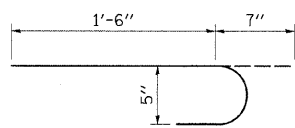

BAR d8(E)

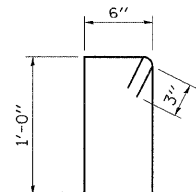

BAR s(E)

BRIDGE APPROACH WINGWALL IMPROVEMENT DETAIL

Northwest Wingwall Only

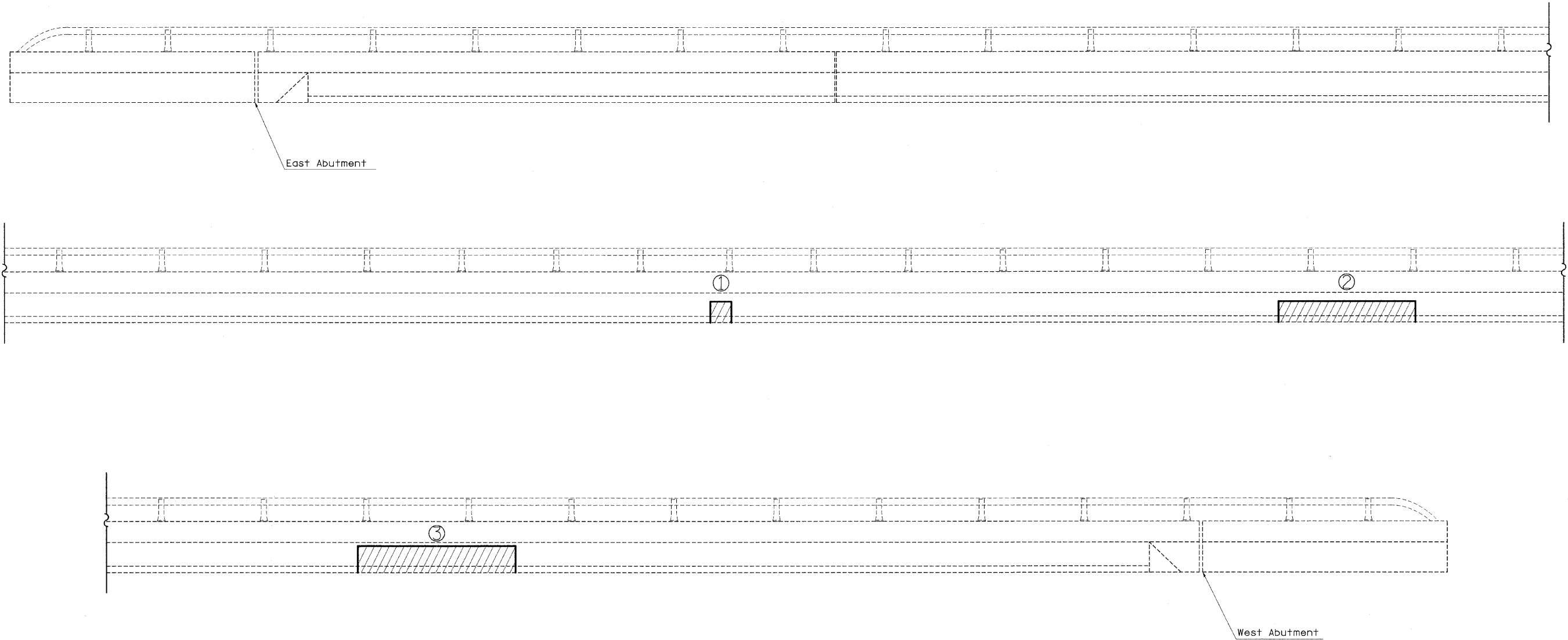

STRUCTURAL REPAIR

Cost Included In Structural Repair
of Concrete (Depth <5')

PATCH NUMBER	STATION	AREA SQ FT
1	800+10	2.0
2	800+69	13.0
3	801+21	18.8
	Total	33.8

SOUTH PARAPET

Looking South

FILE NAME = c:\pw\work\PW100T\SWARTZRW\dms37779\k	USER NAME = swartzrw enbridge.dgn	DESIGNED - DRAWN -	REVISED - REVISED -	STATE OF ILLINOIS DEPARTMENT OF TRANSPORTATION	STRUCTURAL REPAIR - PARAPET SN 058-0095 (EB)		F.A.I. RTE.	SECTION	COUNTY	TOTAL SHEETS	SHEET NO.	
PLOT SCALE = 20.0000' / IN.	CHECKED -	REVISED -	SCALE: N/A		SHEET NO. 10 OF 21 SHEETS	STA.	TO STA.	72	66(B,HVB,HB-1)BR	MACON	83	54
PLOT DATE = 9/28/2009	DATE -	REVISED -					CONTRACT NO. 74343					
							FED. ROAD DIST. NO. ILLINOIS FED. AID PROJECT					

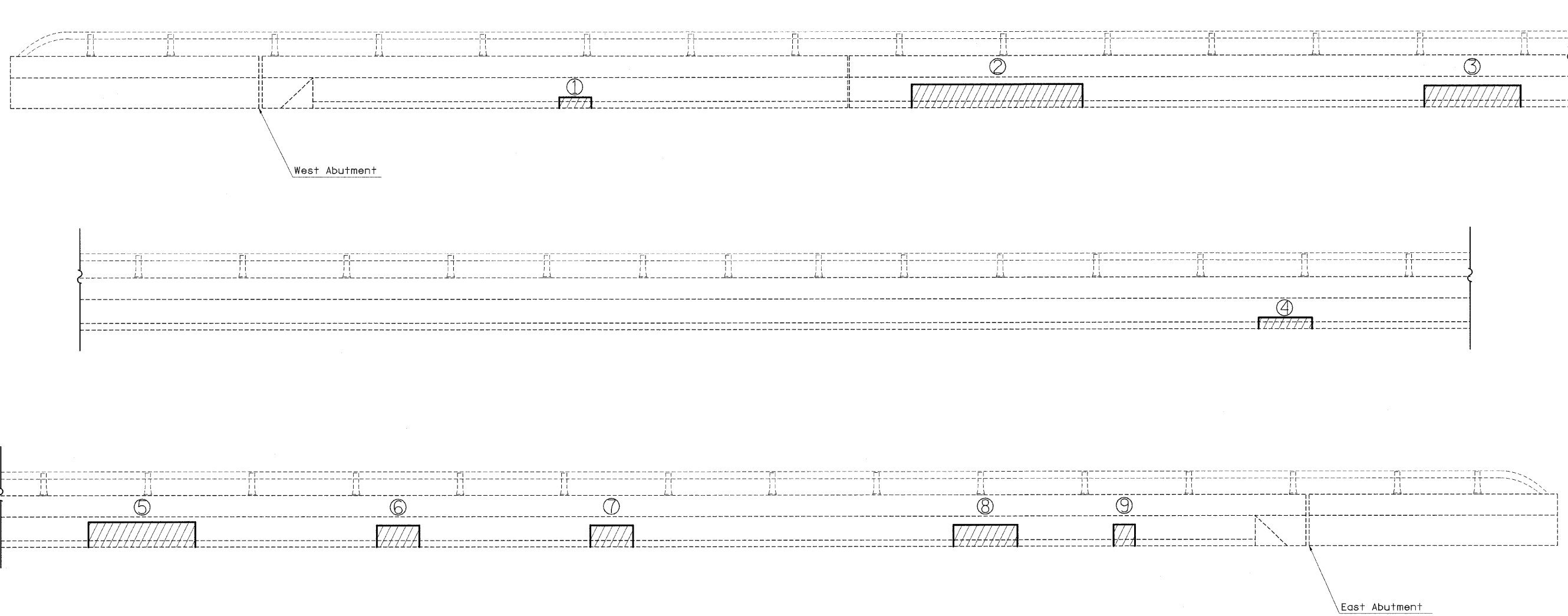

NORTH PARAPET
Looking North

STRUCTURAL REPAIR
Cost Included in Structural Repair
of Concrete (Depth <5'')

PATCH NUMBER	STATION	AREA SQ FT
1	796+69	1.5
2	797+08	17.3
3	797+53	9.0
4	798+75	2.5
5	799+05	11.7
6	799+29	4.0
7	799+49	4.0
8	799+84	6.0
9	799+97	2.0
	Total	58.0

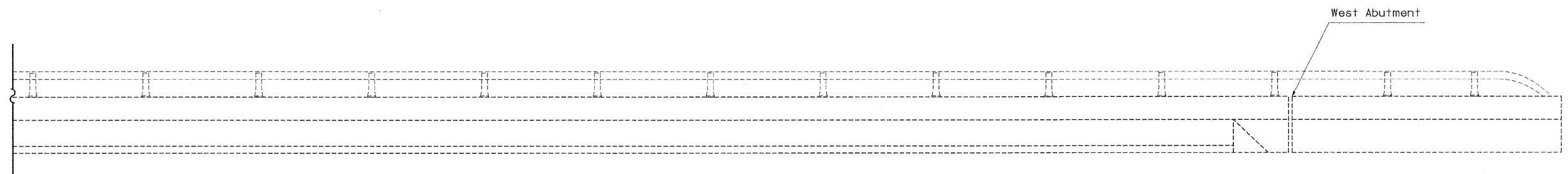
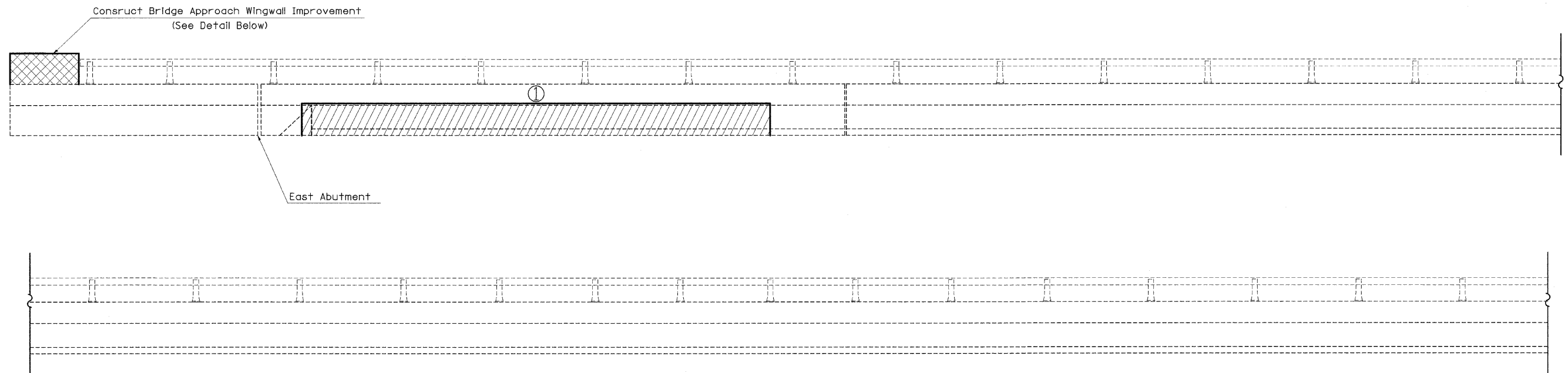

SOUTH PARAPET
Looking South

BILL OF MATERIAL

BAR	NUMBER OF BARS	SIZE	LENGTH	SHAPE	
d8(E)	5	#5	2' - 1"		
s(E)	9	#5	3' - 6"		
h7(E)	4	#5	7' - 8"		
REINFORCEMENT BARS (EPOXY COATED)				POUND	120
CONCRETE SUPERSTRUCTURE				CU YD	0.3

STRUCTURAL REPAIR

Cost Included in Structural Repair of Concrete (Depth <5")

PATCH NUMBER	STATION	AREA SQ. FT.
1	797+11	66.0
Total		66.0

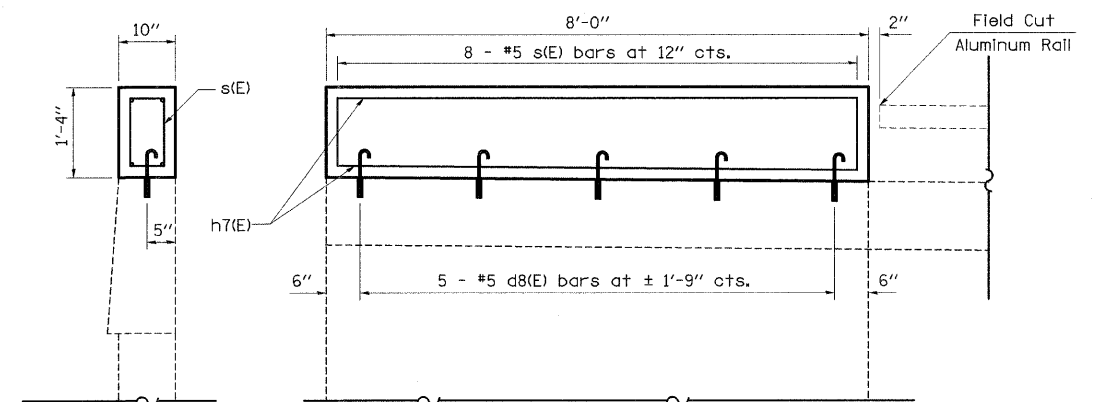

* Epoxy Grouted Bars in accordance with Art. 584 of the Standard Specs.

BRIDGE APPROACH WINGWALL IMPROVEMENT DETAIL
Southeast Wingwall Only

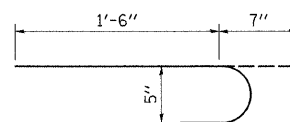

BAR d8(E)

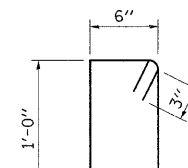

BAR s(E)



PIER #1 - WEST FACE

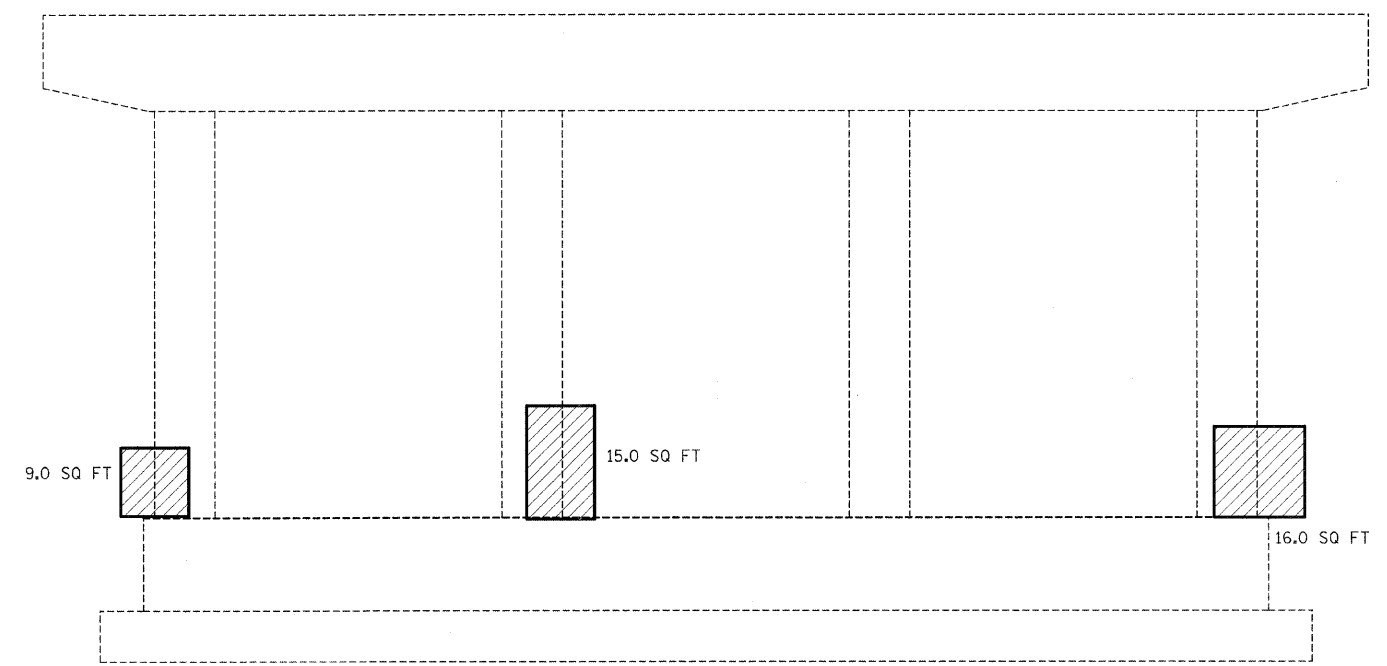

PIER #2 - WEST FACE

NOTE: QUANTITIES ARE ESTIMATED. ACTUAL QUANTITIES TO BE DETERMINED BY THE RESIDENT ENGINEER.

 Structural Repair of Concrete (Depth < 5")

FILE NAME = c:\pwwork\PWIDOT\SWARTZRW\des37779\k...enbridge.dgn	USER NAME = swartzrw	DESIGNED -	REVISED -	STATE OF ILLINOIS DEPARTMENT OF TRANSPORTATION	STRUCTURAL REPAIR - SUBSTRUCTURE SN 058-0095 EB	F.A.I. RTE. 72	SECTION 66(B,HVB,HB-1)BR	COUNTY MACON	TOTAL SHEETS 83	SHEET NO. 57	
PLOT SCALE = 20.0000' / IN.	CHECKED -	REVISED -	SCALE: N/A			SHEET NO. 13 OF 21 SHEETS	STA.	TO STA.	CONTRACT NO. 74343		
PLOT DATE = 9/28/2009	DATE -	REVISED -	FED. ROAD DIST. NO. ILLINOIS FED. AID PROJECT								

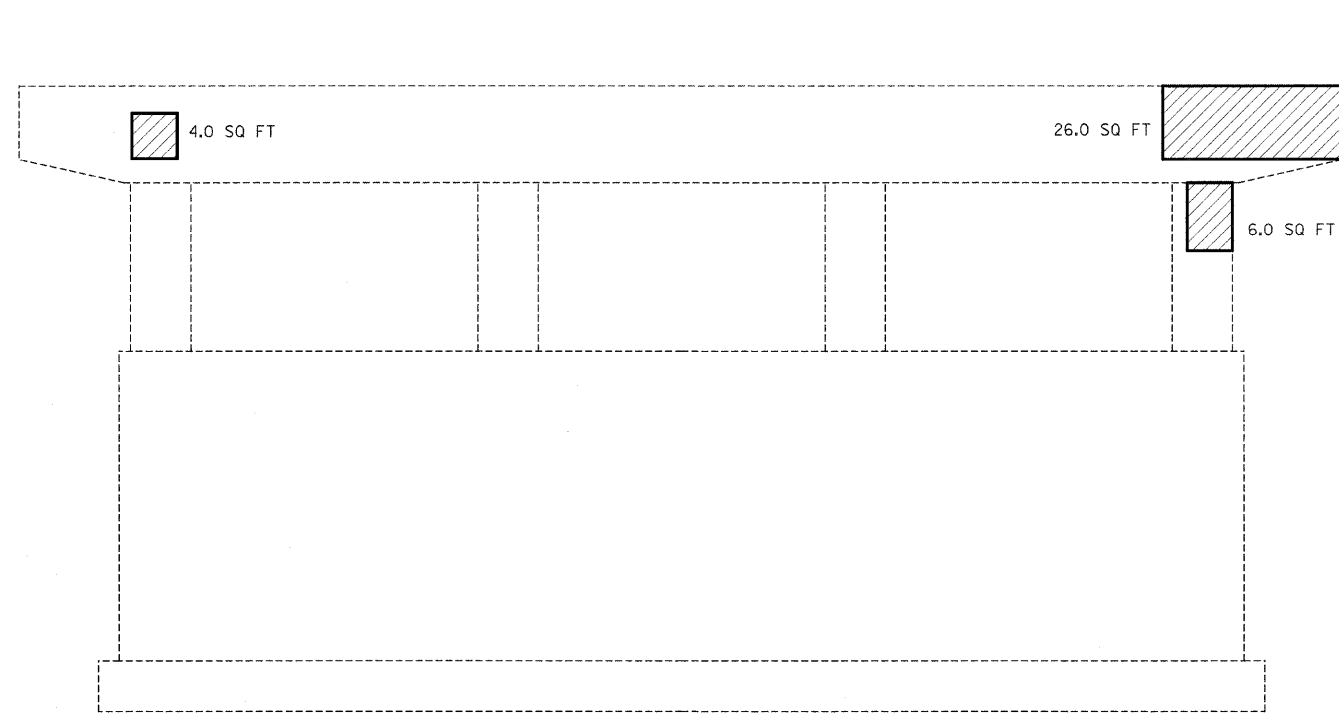

PIER #1 - WEST FACE

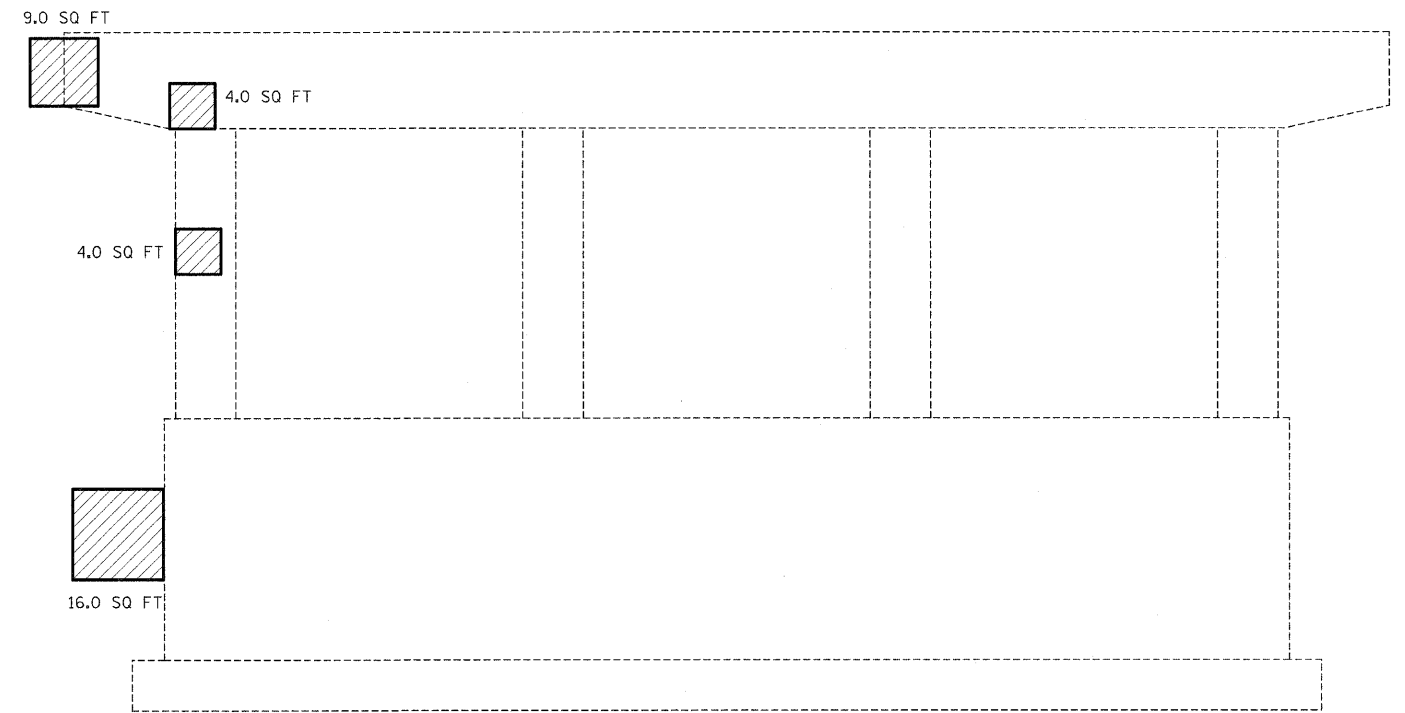

PIER #3 - WEST FACE

NOTE: QUANTITIES ARE ESTIMATED. ACTUAL QUANTITIES TO BE DETERMINED BY THE RESIDENT ENGINEER.

 Structural Repair of Concrete (Depth < 5")

FILE NAME = c:\p\work\PWIDOT\SWARTZRW\dms37779\k...enbridge.dgn	USER NAME = swartzrw	DESIGNED -	REVISED -	STATE OF ILLINOIS DEPARTMENT OF TRANSPORTATION	STRUCTURAL REPAIR - SUBSTRUCTURE SN 058-0096		F.A.I. RTE. 72	SECTION 66(B,HVB,HB-1)BR	COUNTY MACON	TOTAL SHEETS 83	SHEET NO. 58	
PLOT SCALE = 20.0000' / IN.	PLOT DATE = 9/28/2009	DRAWN -	REVISED -		SCALE: N/A	SHEET NO. 14 OF 21 SHEETS	STA. TO STA.	FED. ROAD DIST. NO. ILLINOIS FED. AID PROJECT				
CHECKED -	DATE -	REVISIONS	REVISIONS		CONTRACT NO. 74343							

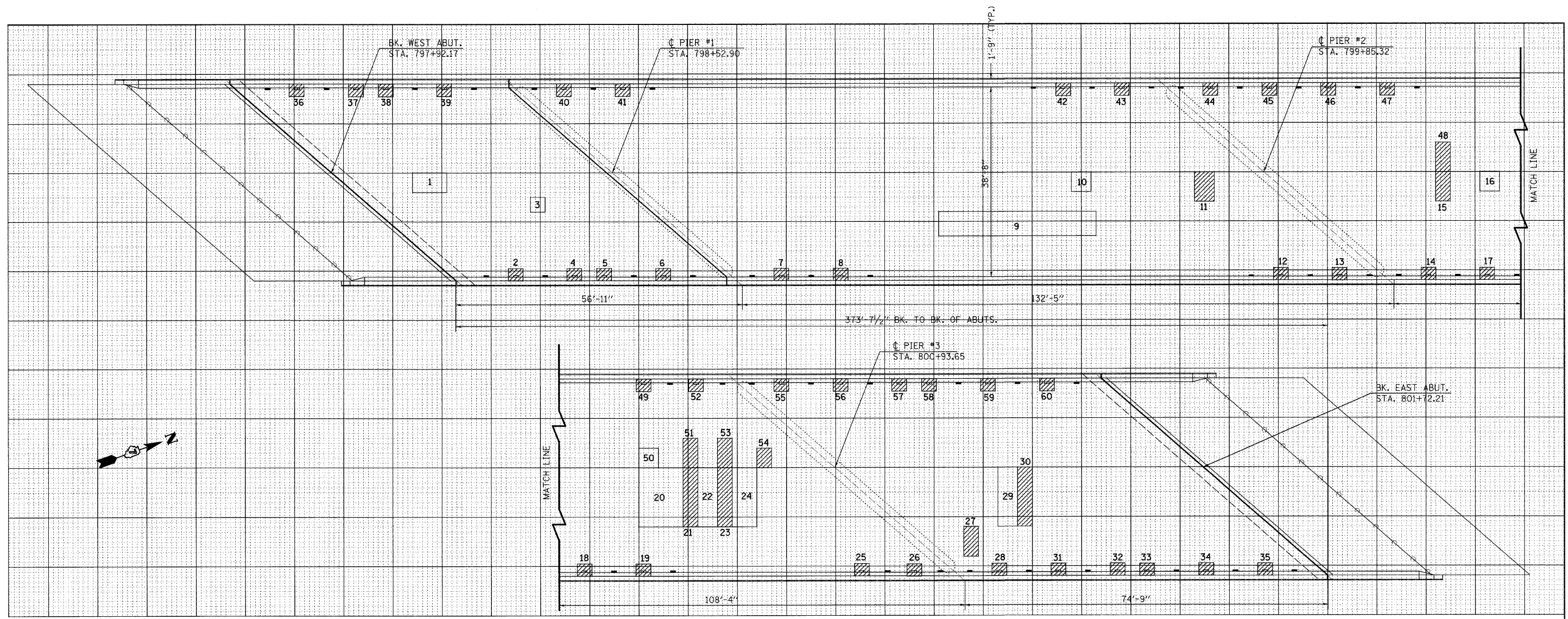

PATCH NO.	SIZE	DECK SLAB REPAIR (PART DEPTH)		
		SQ FT	SQ FT	SQ FT
1	7.0 x 4.0	28.0		
2	1.8 x 1.2		2.2	
3	3.0 x 3.0	9.0		
4	1.8 x 1.2		2.2	
5	1.8 x 1.2		2.2	
6	1.8 x 1.2		2.2	
7	1.8 x 1.2		2.2	
8	1.8 x 1.2		2.2	
9	32.0 x 5.0	160.0		
10	4.0 x 4.0	16.0		
11	4.0 x 6.0			24.0
12	1.8 x 1.2		2.2	
13	1.8 x 1.2		2.2	
14	1.8 x 1.2		2.2	
15	3.0 x 6.0			18.0
16	4.0 x 4.0	16.0		
17	1.8 x 1.2		2.2	
18	1.8 x 1.2		2.2	

PATCH NO.	SIZE	DECK SLAB REPAIR (PART DEPTH)		
		SQ FT	SQ FT	SQ FT
19	1.8 x 1.2		2.2	
20	9.0 x 12.0	108.0		
21	3.0 x 12.0			36.0
22	4.0 x 12.0	48.0		
23	3.0 x 12.0			36.0
24	5.0 x 12.0	60.0		
25	1.8 x 1.2		2.2	
26	1.8 x 1.2		2.2	
27	3.0 x 6.0			18.0
28	1.8 x 1.2		2.2	
29	4.0 x 12.0	48.0		
30	3.0 x 12.0			36.0
31	1.8 x 1.2		2.2	
32	1.8 x 1.2		2.2	
33	1.8 x 1.2		2.2	
34	1.8 x 1.2		2.2	
35	1.8 x 1.2		2.2	
36	1.8 x 1.2		2.2	

PATCH NO.	SIZE	DECK SLAB REPAIR (PART DEPTH)		
		SQ FT	SQ FT	SQ FT
37	1.8 x 1.2		2.2	
38	1.8 x 1.2		2.2	
39	1.8 x 1.2		2.2	
40	1.8 x 1.2		2.2	
41	1.8 x 1.2		2.2	
42	1.8 x 1.2		2.2	
43	1.8 x 1.2		2.2	
44	1.8 x 1.2		2.2	
45	1.8 x 1.2		2.2	
46	1.8 x 1.2		2.2	
47	1.8 x 1.2		2.2	
48	3.0 x 6.0			18.0
49	1.8 x 1.2		2.2	
50	4.0 x 4.0	16.0		
51	3.0 x 6.0			18.0
52	1.8 x 1.2		2.2	
53	3.0 x 6.0			18.0
54	3.0 x 4.0			12.0

PATCH NO.	SIZE	DECK SLAB REPAIR (PART DEPTH)		
		SQ FT	SQ FT	SQ FT
55	1.8 x 1.2		2.2	
56	1.8 x 1.2		2.2	
57	1.8 x 1.2		2.2	
58	1.8 x 1.2		2.2	
59	1.8 x 1.2		2.2	
60	1.8 x 1.2		2.2	
TOTAL		509	88	234
			0	

PATCH NO.	SIZE	DECK SLAB REPAIR (PART DEPTH)		
		SQ FT	SQ FT	SQ FT
PARTIAL DEPTH (FOR INFORMATION ONLY)				
509 / 9 = 56.6				
USE 57 SQ YD				
FULL DEPTH, TYPE 1				
88 / 9 = 9.8				
USE 10 SQ YD				
FULL DEPTH, TYPE 2				
234 / 9 = 26.0				
USE 26 SQ YD				

THE LOCATIONS AND SIZES SHOWN GRAPHICALLY ABOVE ARE APPROXIMATE. SEE THIS TABLE FOR ACTUAL SIZES.

PATCHING LEGEND

- PARTIAL DEPTH (FOR INFORMATION ONLY)
- FULL DEPTH
- FLOOR DRAIN TO BE REPLACED
- FLOOR DRAIN TO BE PLUGGED

DATE OF SURVEY: 10/30/07
 SURVEY BY: M. ALLEN, K. THOLE
 METHOD OF SURVEY: VISUAL

BRIDGE DECK PATCHING
 MACON COUNTY

095

FILE NAME = USER NAME = swartzrw
 c:\pw_work\PWIDOT\SWARTZRW\dms3779\kar\hbr\rdge.dgn
 PLOT SCALE = 50.0000 "/ IN.
 PLOT DATE = 9/28/2009

DESIGNED - REVISED -
 DRAWN - REVISED -
 CHECKED - REVISED -
 DATE - REVISED -

STATE OF ILLINOIS
 DEPARTMENT OF TRANSPORTATION

DECK SLAB REPAIR
 S.N. 058-0095 (E.B.)
 SCALE: 50 SHEET NO. 15 OF 21 SHEETS STA. TO STA.

F.A.I. RTE.	SECTION	COUNTY	TOTAL SHEETS	SHEET NO.
72	66(B,HVB,HB-1)BR	MACON	83	59
CONTRACT NO. 74343			ILLINOIS FED. AID PROJECT	

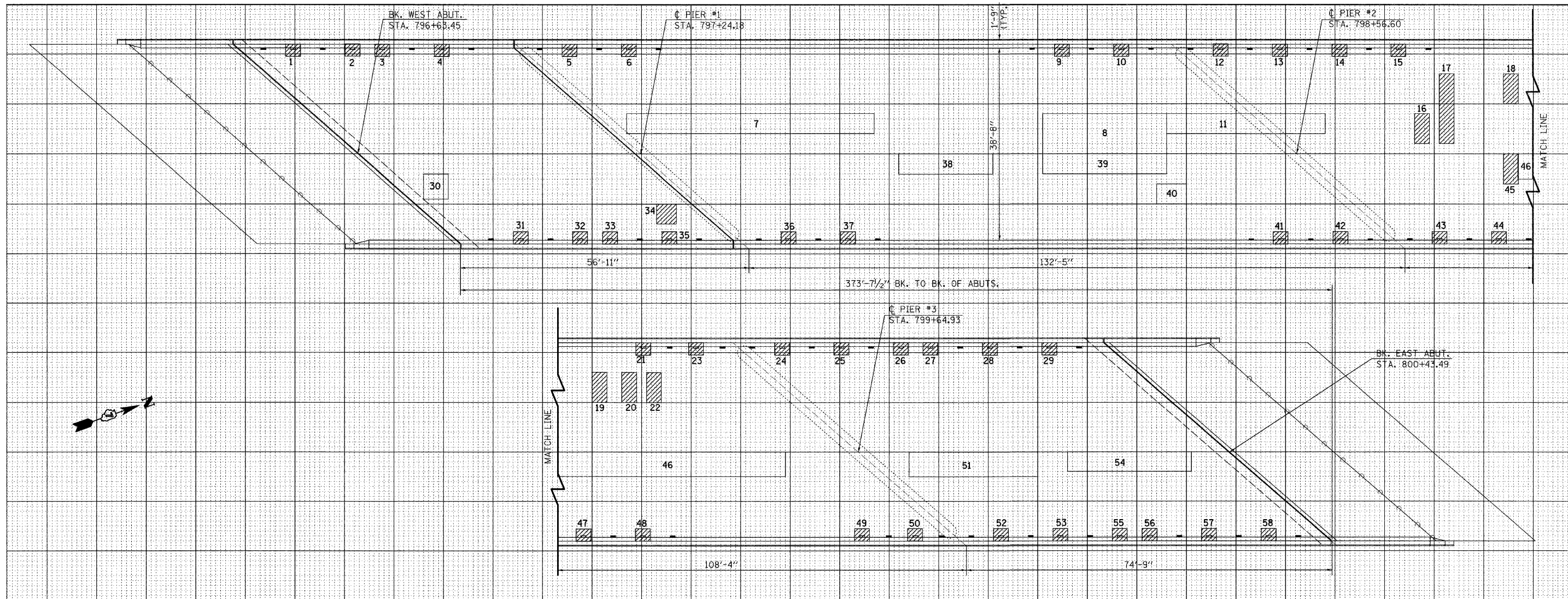

PATCH NO.	SIZE	DECK SLAB REPAIR (PART DEPTH)		
		SO FT	SO FT	SO FT
1	1.8 x 1.2		2.2	
2	1.8 x 1.2		2.2	
3	1.8 x 1.2		2.2	
4	1.8 x 1.2		2.2	
5	1.8 x 1.2		2.2	
6	1.8 x 1.2		2.2	
7	50.0 x 4.0	200.0		
8	25.0 x 8.0	200.0		
9	1.8 x 1.2		2.2	
10	1.8 x 1.2		2.2	
11	32.0 x 4.0	128.0		
12	1.8 x 1.2		2.2	
13	1.8 x 1.2		2.2	
14	1.8 x 1.2		2.2	
15	1.8 x 1.2		2.2	
16	3.0 x 6.0			18.0
17	3.0 x 14.0			42.0
18	3.0 x 6.0			18.0

PATCH NO.	SIZE	DECK SLAB REPAIR (PART DEPTH)		
		SO FT	SO FT	SO FT
19	3.0 x 6.0			18.0
20	3.0 x 6.0			18.0
21	1.8 x 1.2		2.2	
22	3.0 x 6.0			18.0
23	1.8 x 1.2		2.2	
24	1.8 x 1.2		2.2	
25	1.8 x 1.2		2.2	
26	1.8 x 1.2		2.2	
27	1.8 x 1.2		2.2	
28	1.8 x 1.2		2.2	
29	1.8 x 1.2		2.2	
30	5.0 x 5.0	25.0		
31	1.8 x 1.2		2.2	
32	1.8 x 1.2		2.2	
33	1.8 x 1.2		2.2	
34	4.0 x 4.0			16.0
35	1.8 x 1.2		2.2	
36	1.8 x 1.2		2.2	

PATCH NO.	SIZE	DECK SLAB REPAIR (PART DEPTH)		
		SO FT	SO FT	SO FT
37	1.8 x 1.2		2.2	
38	19.0 x 4.0	76.0		
39	25.0 x 4.0			100.0
40	6.0 x 4.0			24.0
41	1.8 x 1.2		2.2	
42	1.8 x 1.2		2.2	
43	1.8 x 1.2		2.2	
44	1.8 x 1.2		2.2	
45	3.0 x 6.0			18.0
46	52.0 x 5.0	260.0		
47	1.8 x 1.2		2.2	
48	1.8 x 1.2		2.2	
49	1.8 x 1.2		2.2	
50	1.8 x 1.2		2.2	
51	26.0 x 5.0	130.0		
52	1.8 x 1.2		2.2	
53	1.8 x 1.2		2.2	
54	25.0 x 4.0	100.0		

PATCH NO.	SIZE	DECK SLAB REPAIR (PART DEPTH)			
		SO FT	SO FT	SO FT	SO FT
55	1.8 x 1.2		2.2		
56	1.8 x 1.2		2.2		
57	1.8 x 1.2		2.2		
58	1.8 x 1.2		2.2		
TOTAL		1119	88	290	0

PATCH NO.	SIZE	DECK SLAB REPAIR (PART DEPTH)		
		SO FT	SO FT	SO FT
PARTIAL DEPTH				
1119 / 9 = 124.3				
USE 124 SQ YD				
FULL DEPTH, TYPE 1				
88 / 9 = 9.8				
USE 10 SQ YD				
FULL DEPTH, TYPE 2				
290 / 9 = 32.2				
USE 32 SQ YD				

THE LOCATIONS AND SIZES SHOWN GRAPHICALLY ABOVE ARE APPROXIMATE. SEE THIS TABLE FOR ACTUAL SIZES.

PATCHING LEGEND

- PARTIAL DEPTH (FOR INFORMATION ONLY)
- FULL DEPTH
- FLOOR DRAIN TO BE REPLACED
- FLOOR DRAIN TO BE PLUGGED

DATE OF SURVEY: 10/30/07
 SURVEY BY: M. ALLEN, K. THOLEE
 METHOD OF SURVEY: VISUAL

BRIDGE DECK PATCHING
 MACON COUNTY

096

FILE NAME = c:\pwwork\p\1001\SWARTZRW\dms37779\karcbridge.dgn
 USER NAME = swartzrw
 PLOT SCALE = 50.0000' / IN.
 PLOT DATE = 9/28/2009

DESIGNED -
 DRAWN -
 CHECKED -
 DATE -

REVISED -
 REVISED -
 REVISED -
 REVISED -

STATE OF ILLINOIS
 DEPARTMENT OF TRANSPORTATION

DECK SLAB REPAIR
 S.N. 058-0096 (W.B.)
 SCALE: 50 SHEET NO. 16 OF 21 SHEETS STA. TO STA.

F.A.I. SECTION COUNTY TOTAL SHEETS SHEET NO.
 72 66(B,HV,B,HB-1)BR MACON 83 60
 FED. ROAD DIST. NO. ILLINOIS FED. AID PROJECT CONTRACT NO. 74343

STATE OF ILLINOIS
DEPARTMENT OF TRANSPORTATION

NOTES

All structural steel shall conform to AASHTO Classification M-270 Gr. 36, unless otherwise noted.

Plan dimensions and details relative to existing plans are subject to routine variations. The Contractor shall field verify existing dimensions and details affecting new construction and make necessary approved adjustments prior to construction or ordering of materials. Such variations shall not be cause for additional compensation for a change in scope of the work, however, the Contractor will be paid for the quantity actually furnished based upon the unit price bid for the work.

If the analysis submitted to the Contractor for the jacking/temporary support system to be used shows temporary stiffeners are required to prevent web crippling or buckling, the stiffeners shall be steel and bolted to the web. If stiffeners are not required, hardwood timbers shall be installed tightly between the top and bottom flange to prevent flange rotation.

The existing structural steel coating contains lead. The Contractor shall take appropriate precautions to deal with the presence of lead on this project.

Existing structural steel that will be in contact with new structural steel shall be cleaned and painted prior to erection as required by the Special Provision "Cleaning and Painting Contact Surface Areas of Existing Steel Structures".

All structural steel shall be shop painted with the inorganic zinc rich primer per AASHTO M300, Type 1. Cost included with Furnishing and Erecting Structural Steel.

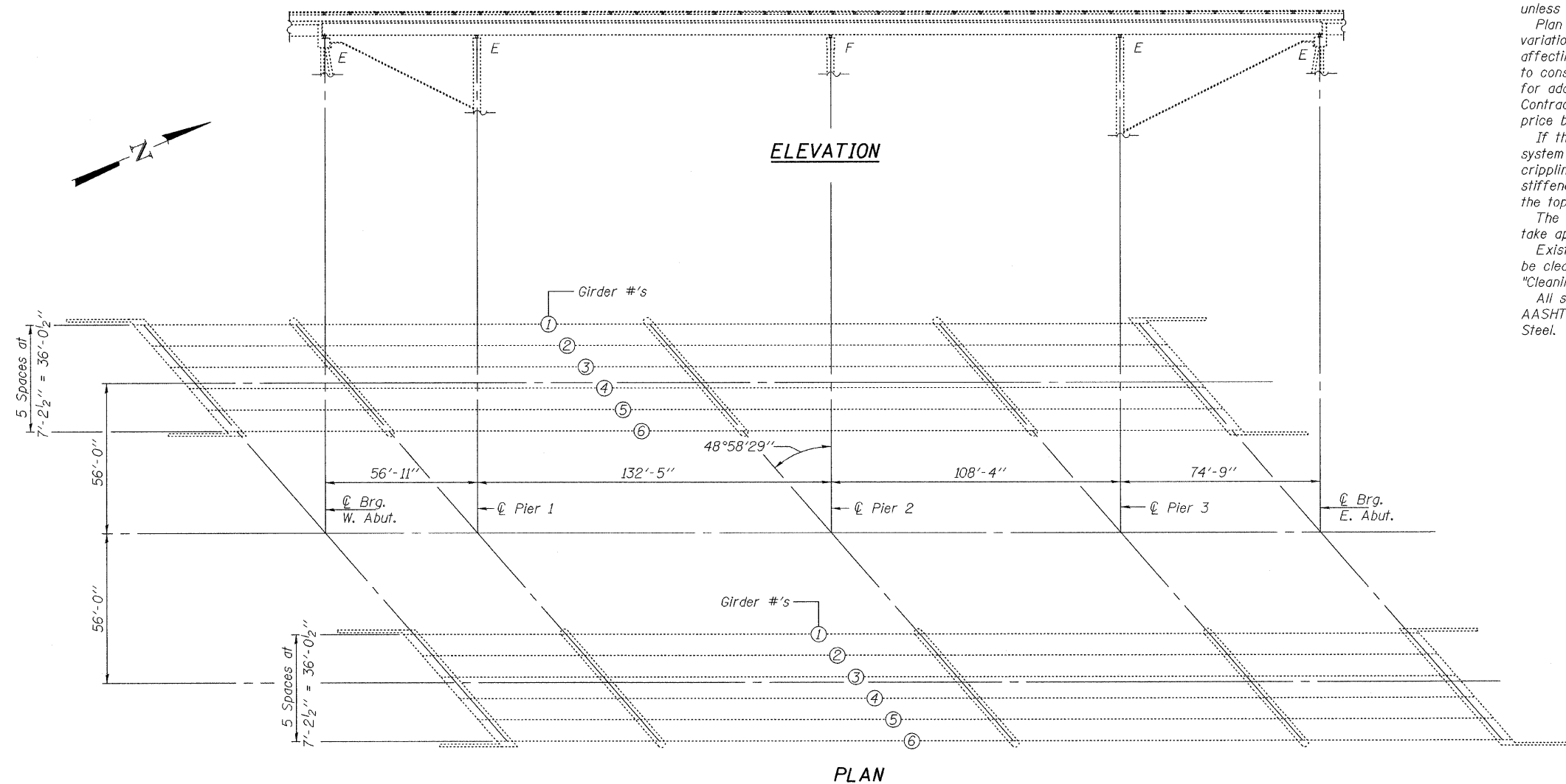

BILL OF MATERIAL

ITEM	UNIT	TOTAL
Furnishing & Erecting Structural Steel	Pound	3420
Anchor Bolts, 1"φ	Each	48
Elastomeric Bearing Assembly, Type II	Each	24
Jack and Remove Existing Bearings	Each	24

**BEARING REPLACEMENT
PLAN & ELEVATION
SN 058-0095 & 0096**

DESIGNED *Augie Bryant*
CHECKED *Sital Dhalke*
DRAWN *Steffen*
CHECKED *VAV*

OCTOBER 30, 2009
EXAMINED *[Signature]*
PASSED *[Signature]*
ENGINEER OF STRUCTURAL SERVICES
ENGINEER OF BRIDGES AND STRUCTURES



EXPIRES 11-30-2010

SHEET NO. 17 21 SHEETS	F.A.I. RTE.	SECTION	COUNTY	TOTAL SHEETS	SHEET NO.
	72	66(B,HVB,HB-1)BR	MACON	83	61
FED. ROAD DIST. NO.			ILLINOIS FED. AID PROJECT		
CONTRACT NO. 74343					

STATE OF ILLINOIS
DEPARTMENT OF TRANSPORTATION

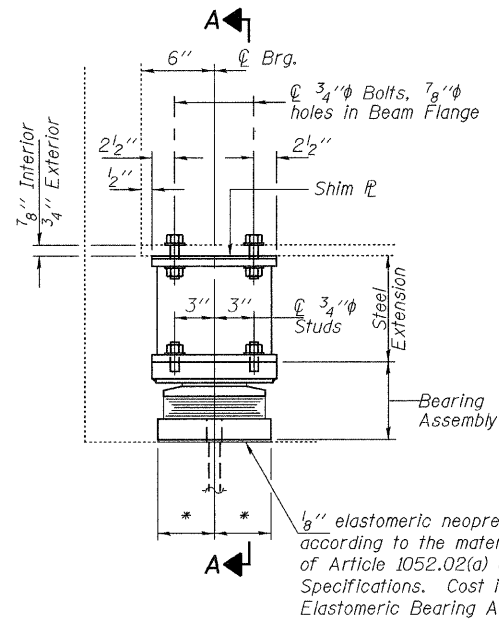

ELEVATION AT ABUTMENTS

TYPE II TFE ELASTOMERIC EXP. BRG.

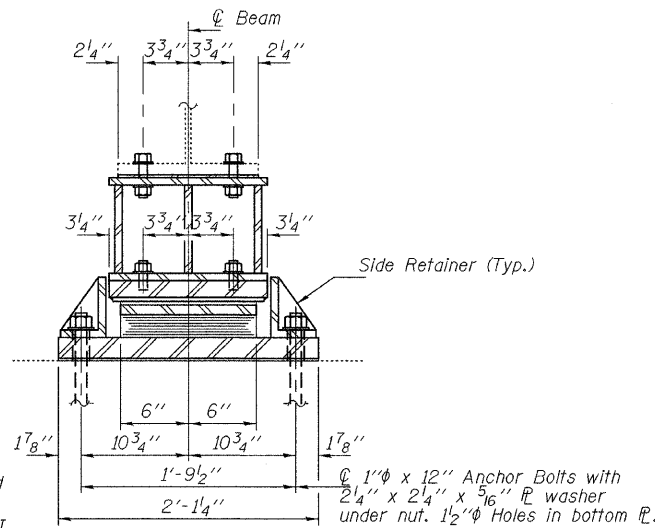

SECTION A-A

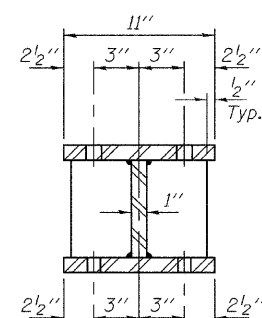

SECTION B-B

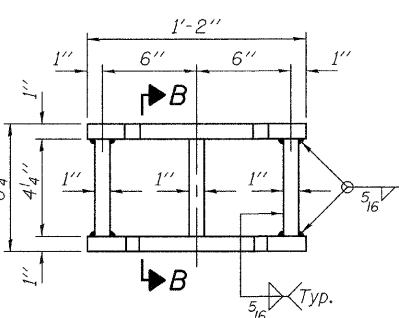

STEEL EXTENSION DETAIL

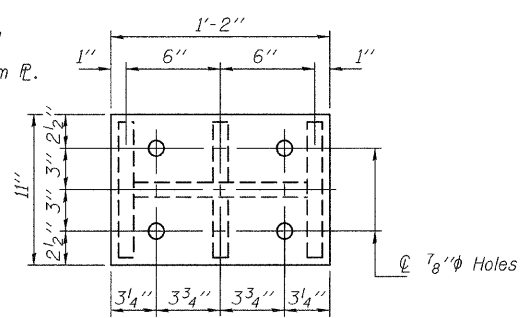

PLAN TOP AND BOTTOM PLATE

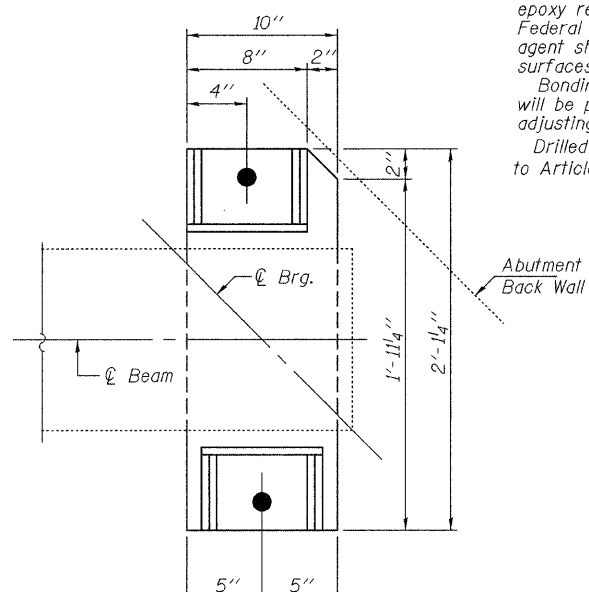

PLAN VIEW OF BOTTOM BEARING PLATE

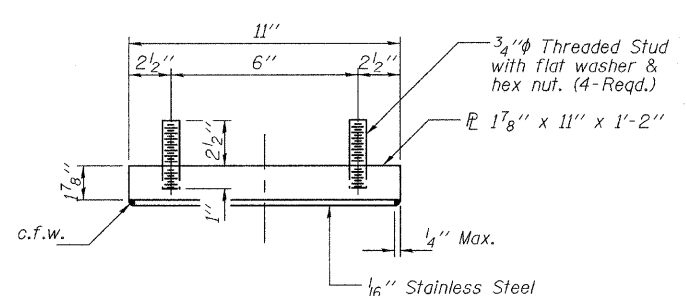

TOP BEARING ASSEMBLY

* 1/8" PTFE dimpled, unlubricated

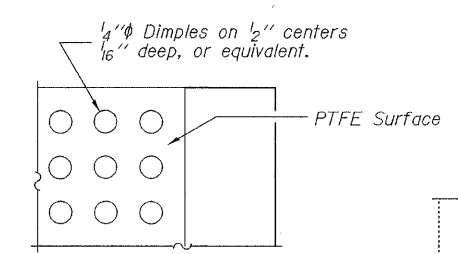

PLAN-TFE SURFACE

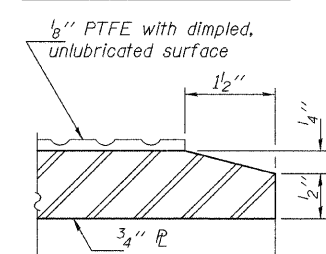

SECTION THRU TFE

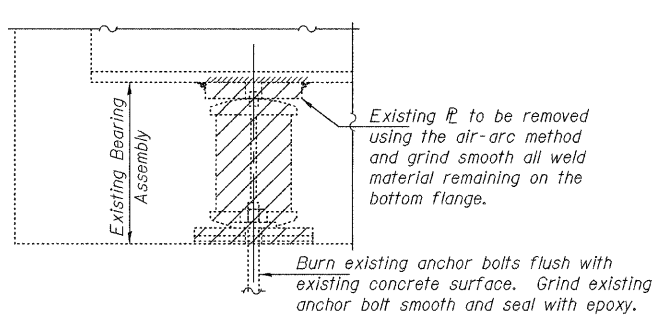

EXISTING BEARING REMOVAL DETAIL

Cost included with Jack and Remove Existing Bearings.

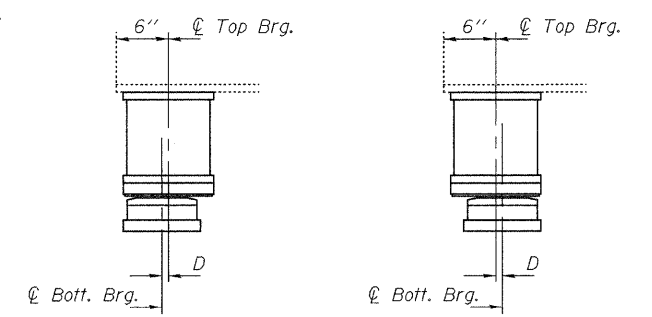

SHIM PLATES

SN 058-0095 at W. Abut.	
Girder 3	5/8" x 11" x 12"
Girder 4	5/8" x 11" x 12"

SN 058-0096 at W. Abut.	
Girder 4	1/4" x 11" x 12"

BELOW 50° F. (Move bott. brg. away from fixed brg.)
ABOVE 50° F. (Move bott. brg. toward fixed brg.)

SETTING ANCHOR BOLTS AT EXP. BRG.

D = 1/8" per each 100' of expansion for every 15° temp. change from the normal temp. of 50°F.

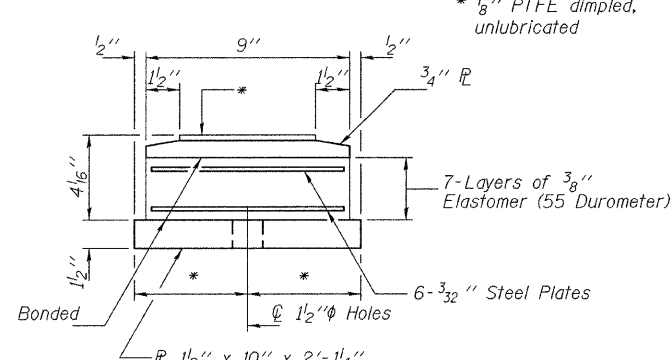

BOTTOM BEARING ASSEMBLY

* For hole location see Plan View of Bottom Bearing Plate

DESIGNED	AJB
CHECKED	SJB
DRAWN	Steffen
CHECKED	AJB SJB

OCTOBER 30, 2009
EXAMINED *Carl P. ...*
ENGINEER OF STRUCTURAL SERVICES
PASSED *Ralph E. Anderson*
ENGINEER OF BRIDGES AND STRUCTURES

SIDE RETAINER

Equivalent rolled angle with stiffeners will be allowed in lieu of welded plates.

Notes:
Diaphragm removal and reinstallation may be required to facilitate drilling holes. Cost included with Furnishing and Erecting Structural Steel.
New steel extensions, shim plates and connection bolts are included with Furnishing and Erecting Structural Steel.
Prior to ordering any material, the Contractor shall verify in the field all bearing height and shim thickness dimensions. Min. jack capacity = 50 Tons.
Anchor bolts shall be ASTM F1554 all-thread (or an Engineer-approved alternate material) of the grade(s) and diameter(s) specified. ASTM A307 Grade C anchor bolts may be used in lieu of ASTM F1554 Grade 36 (Fy=36ksi). The corresponding specified grade of AASHTO M314 anchor bolts may be used in lieu of ASTM F1554.
Anchor bolts for Type II bearings shall be placed in holes drilled through the bottom bearing plate after members are in place. Side retainers shall be placed after bolts are installed.
Side retainers shall be included in the cost of Elastomeric Bearing Assembly, Type II.
The 1/8" PTFE sheet shall be bonded directly to the top steel plate with a two-component, medium viscosity epoxy resin, conforming to the requirements of the Federal Specification MMM-A-134, Type I. The bond agent shall be applied on the full area of the contact surfaces.
Bonding of 1/8" PTFE sheet during vulcanizing process will be permitted provided the process and method of adjusting assembly height is approved by the Engineer.
Drilled and set anchor bolts shall be installed according to Article 521.06 of the Standard Specifications.

EAST ABUTMENT BEAM REACTIONS

R ϕ	(K)	38.8
R \perp	(K)	43.9
Imp.	(K)	11.0
R (Total)	(K)	93.7

WEST ABUTMENT BEAM REACTIONS

R ϕ	(K)	35.1
R \perp	(K)	44.7
Imp.	(K)	12.3
R (Total)	(K)	92.1

BILL OF MATERIAL

Item	Unit	Total
Elastomeric Bearing Assembly Type II	Each	24
Jack and Remove Existing Bearings	Each	24
Furnishing and Erecting Structural Steel	Pound	3420
Anchor Bolts, 1" ϕ	Each	48

ABUTMENT BEARING REPLACEMENT DETAILS
SN 058-0095 & 0096

SHEET NO. 18	F.A.I. RTE.	SECTION	COUNTY	TOTAL SHEETS	SHEET NO.
21 SHEETS	72	66(B,HVB,HB-1)BR	MACON	83	62
FED. ROAD DIST. NO.			ILLINOIS FED. AID PROJECT		
CONTRACT NO. 74343					

STATE OF ILLINOIS
DEPARTMENT OF TRANSPORTATION

Notes:
See sheet 20 of 21 for Sections C-C & D-D.
a(E) thru a₇(E), and w(E) bar spacings measured perpendicular to \perp Rdwy.

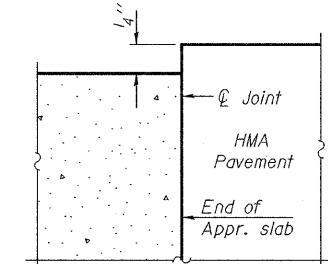
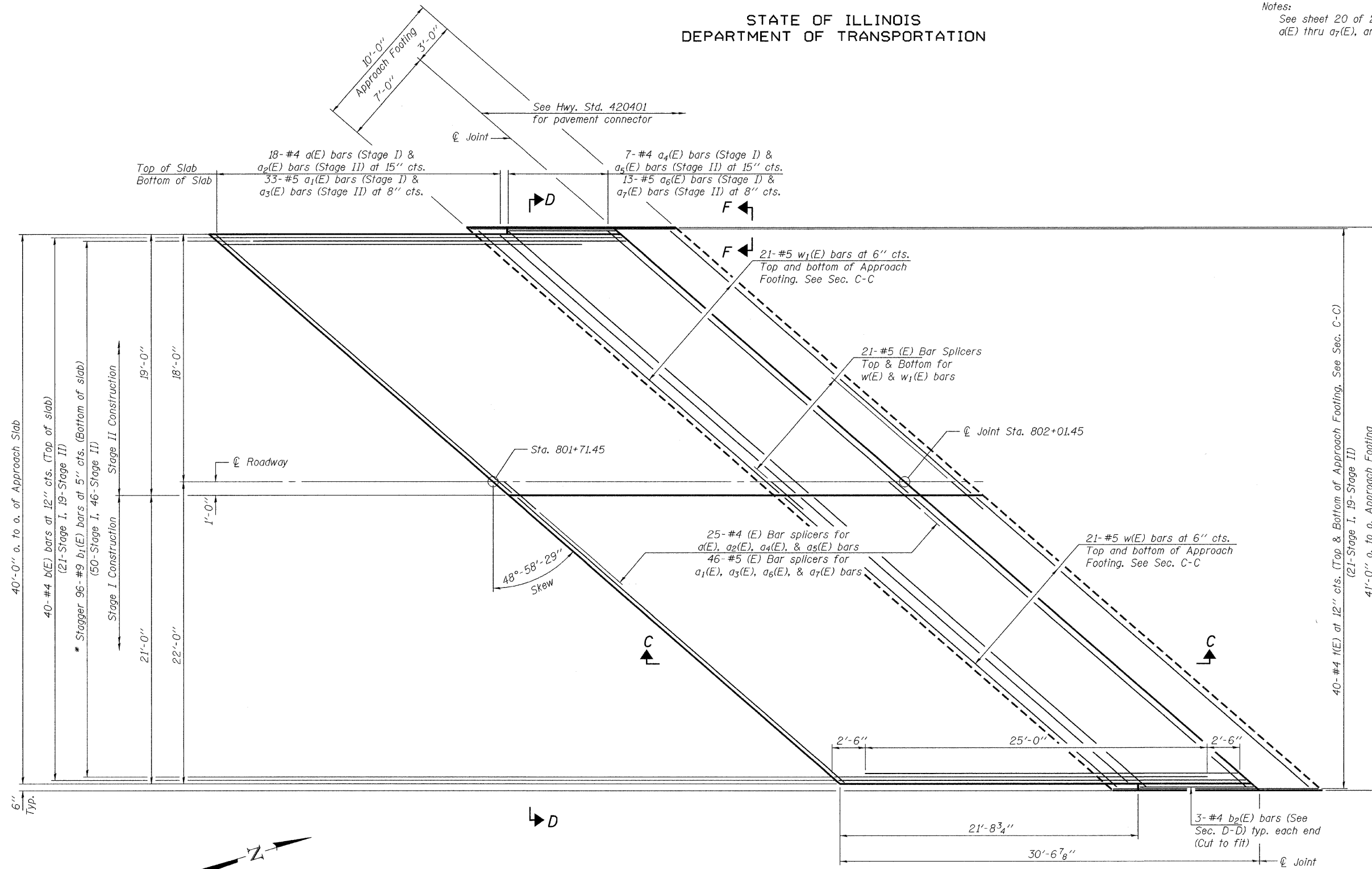

FLEXIBLE PAVEMENT
DETAIL A

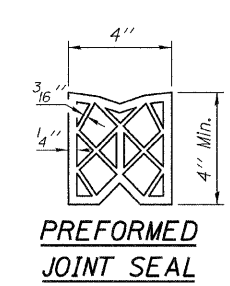

PREFORMED JOINT SEAL

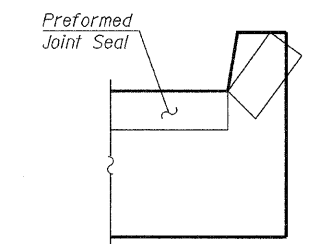

VIEW F-F

Angle Preformed Joint Seal at 45° at curbs when req'd for drainage.

PLAN - EAST APPROACH

DESIGNED	<i>V. H. Veliz</i>
CHECKED	<i>[Signature]</i>
DRAWN	Kyle M. Steffen
CHECKED	<i>VHV</i>

OCTOBER 30, 2009
EXAMINED *[Signature]*
PASSED *[Signature]*
ENGINEER OF BRIDGES AND STRUCTURES



Expires: November 30, 2010

EAST APPROACH PLAN
SN 058-0095

SHEET NO. 19 21 SHEETS	F.A.I. RTE.	SECTION	COUNTY	TOTAL SHEETS	SHEET NO.
	72	66(B,HVB,HB-1)BR	MACON	83	63
FED. ROAD DIST. NO.			ILLINOIS	FED. AID PROJECT	
CONTRACT NO. 74343					

STATE OF ILLINOIS
DEPARTMENT OF TRANSPORTATION

NOTES:
See sheet 19 of 21 for Detail A.
Approach Slab shall be paid for as Concrete Superstructure.
Approach Footing concrete shall be paid for as Concrete Structures.
Reinforcement shall be paid for as Reinforcement Bars, Epoxy Coated.
The Approach Footing maximum applied service bearing pressure (Q_{max}) = 2.0 ksf.
For Bar Splicer details, see sheet 21 of 21.
Cost of excavation for Approach Footing included with Concrete Structures.

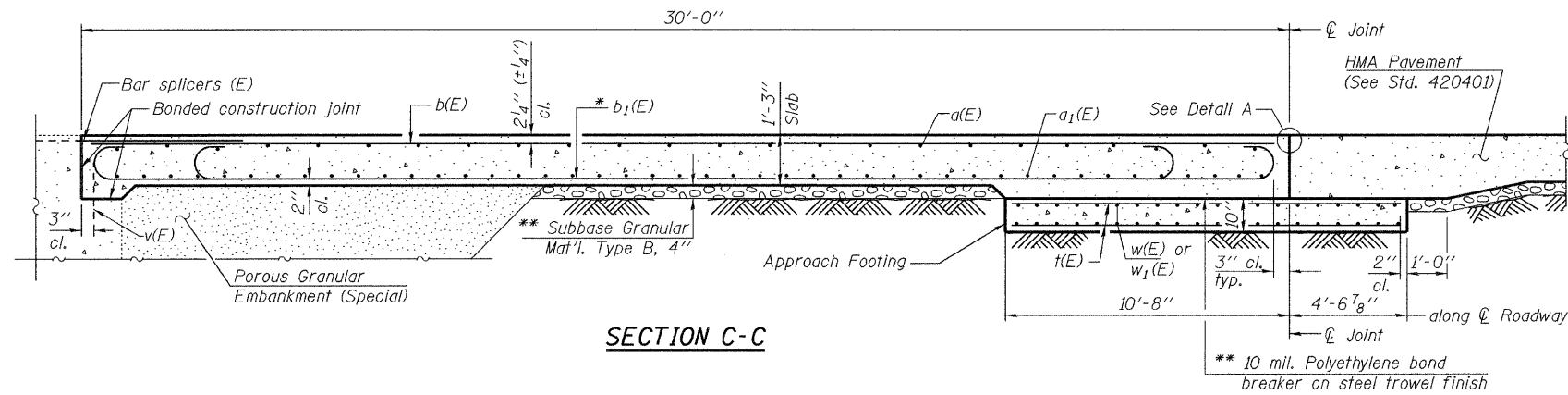

SECTION C-C

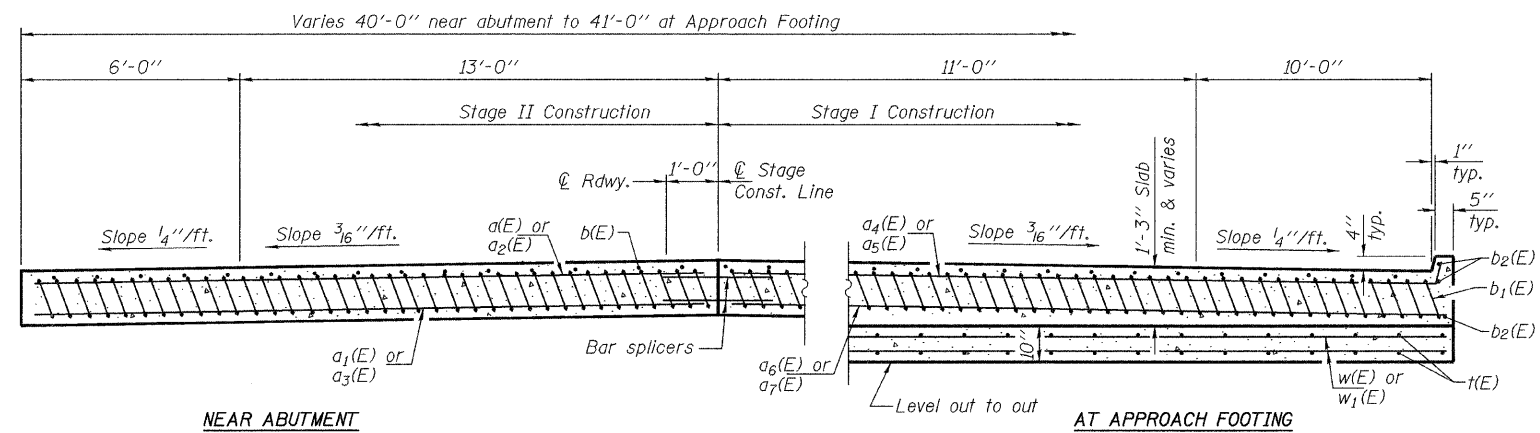

NEAR ABUTMENT

AT APPROACH FOOTING

SECTION D-D

(See Plan for dimensions not shown)

* Tilt #9 $b_1(E)$ bars as required to maintain clearance.

** Cost included with Concrete Superstructure.

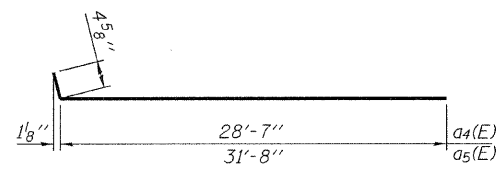

BARS $a_4(E)$ & $a_5(E)$

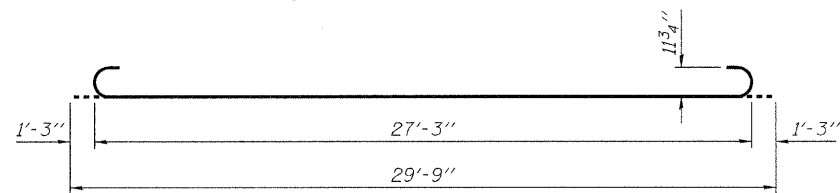

BAR $b_1(E)$

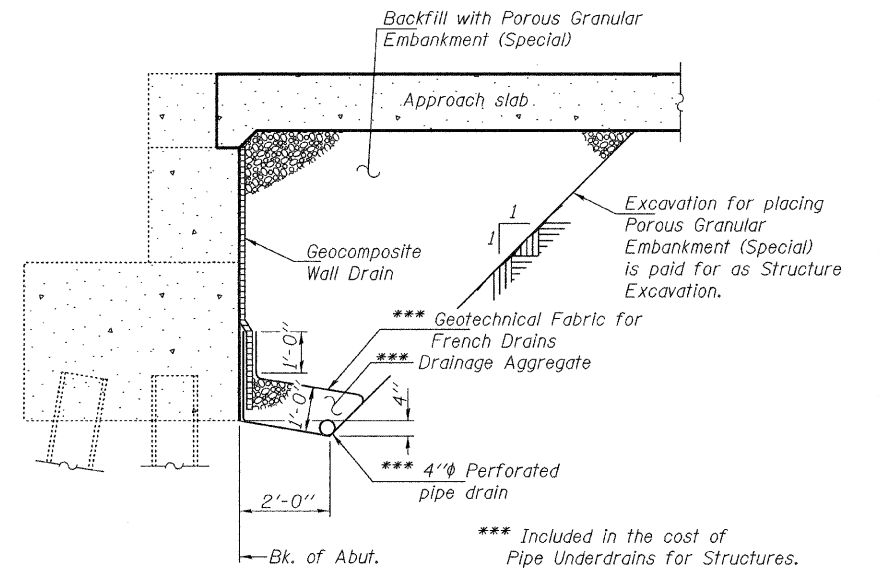

SECTION THRU PILE SUPPORTED
STUB ABUTMENT
(Horiz. dim. @ Rt. L's)

Note:
All drainage system components shall extend parallel to the abutment back wall until they intersect the wingwalls or 2'-0" from the end of the wingwalls when the wings are parallel to the abutment. The pipe shall extend under the wingwall, if necessary, until intersecting the side slopes. The pipes shall drain into concrete headwalls. (See Article 601.05 of the Standard Specifications and Highway Standard 60110).

BILL OF MATERIAL

Bar	No.	Size	Length	Shape
$a(E)$	18	#4	28'-7"	—
$a_1(E)$	33	#5	31'-8"	—
$a_2(E)$	18	#4	28'-7"	—
$a_3(E)$	33	#5	31'-8"	—
$a_4(E)$	7	#4	29'-0"	—
$a_5(E)$	7	#4	32'-1"	—
$a_6(E)$	13	#5	28'-7"	—
$a_7(E)$	13	#5	31'-8"	—
$b(E)$	40	#4	29'-1"	—
$b_1(E)$	96	#9	29'-9"	—
$b_2(E)$	6	#4	8'-2"	—
$t(E)$	80	#4	14'-11"	—
$w(E)$	42	#5	32'-5"	—
$w_1(E)$	42	#5	29'-4"	—
Concrete Superstructure		Cu. Yd.	55.6	
Concrete Structures		Cu. Yd.	19.3	
Reinforcement Bars, Epoxy Coated		Pound	17990	
Porous Granular Embankment (Special)		Cu. Yd.	152	
Geocomposite Wall Drain		Sq. Yd.	70	
Pipe Underdrain for Structures, 4"		Feet	72	
Temporary Soil Retention System		Sq. Ft.	70	
Structure Excavation		Cu. Yd.	152	

EAST APPROACH DETAILS
SN 058-0095

DESIGNED	VHV
CHECKED	DAB
DRAWN	Kyle M. Steffen
CHECKED	VHV DAB

OCTOBER 30, 2009
EXAMINED *A. Carl Proyer*
ENGINEER OF STRUCTURAL SERVICES
PASSED *Ralph E. Anderson*
ENGINEER OF BRIDGES AND STRUCTURES

SHEET NO. 20 21 SHEETS	F.A.I. RTE.	SECTION	COUNTY	TOTAL SHEETS	SHEET NO.
	72	66(B,HVB,HB-1)BR	MACON	83	64
FED. ROAD DIST. NO.			ILLINOIS	FED. AID PROJECT	
CONTRACT NO. 74343					

STATE OF ILLINOIS
DEPARTMENT OF TRANSPORTATION

The diameter of this part is the same as the diameter of the bar spliced.

The diameter of this part is equal or larger than the diameter of bar spliced.

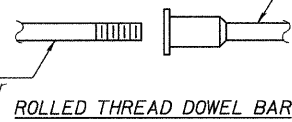

** ONE PIECE

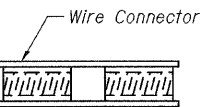

WELDED SECTIONS

BAR SPLICER ASSEMBLY ALTERNATIVES

**Heavy Hex Nuts conforming to ASTM A 563, Grade C, D or DH may be used.

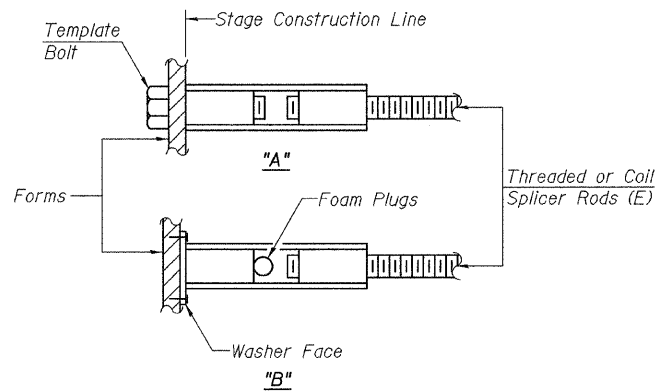

INSTALLATION AND SETTING METHODS

"A" : Set bar splicer assembly by means of a template bolt.
"B" : Set bar splicer assembly by nailing to wood forms or cementing to steel forms.
(E) : Indicates epoxy coating.

NOTES

Bar splicer assemblies shall be of an approved type and shall develop in tension at least 125 percent of the yield strength of the lapped reinforcement bars.
Splicer rods shall be of minimum 60 ksi yield strength, threaded or coiled full length.
All reinforcement bars shall be lapped and tied to the splicer rods or dowel bars.
Bar splicer assemblies shall be epoxy coated according to the requirements for reinforcement bars.
Other systems of similar design may be submitted to the Engineer for approval. Approval shall be based on certified test results from an approved testing laboratory that the proposed bar splicer assembly satisfies the following requirements:

- ① Minimum Capacity = $1.25 \times f_y \times A_t$
(Tension in kips)
 - ② Minimum *Pull-out Strength = $0.66 \times f_y \times A_t$
(Tension in kips)
- Where f_y = Yield strength of lapped reinforcement bars in ksi.
 A_t = Tensile stress area of lapped reinforcement bars.
* = 28 day concrete

Bar Size to be Spliced	Splicer Rod or Dowel Bar Length	Strength Requirements	
		Min. Capacity kips - tension	Min. Pull-Out Strength kips - tension
#4	1'-8"	14.7	7.9
#5	2'-2"	23.0	12.3
#6	2'-7"	33.1	17.4
#7	3'-5"	45.1	23.8
#8	4'-6"	58.9	31.3
#9	5'-9"	75.0	39.6
#10	7'-3"	95.0	50.3
#11	9'-0"	117.4	61.8

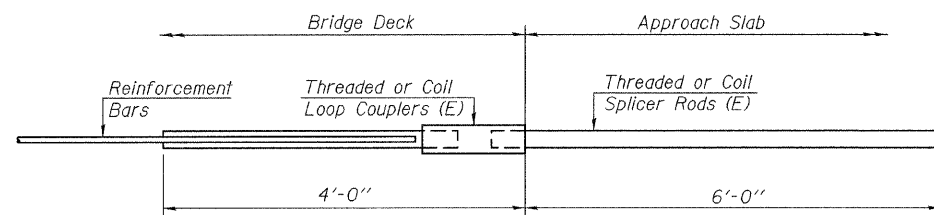

FOR INTEGRAL OR SEMI-INTEGRAL ABUTMENTS

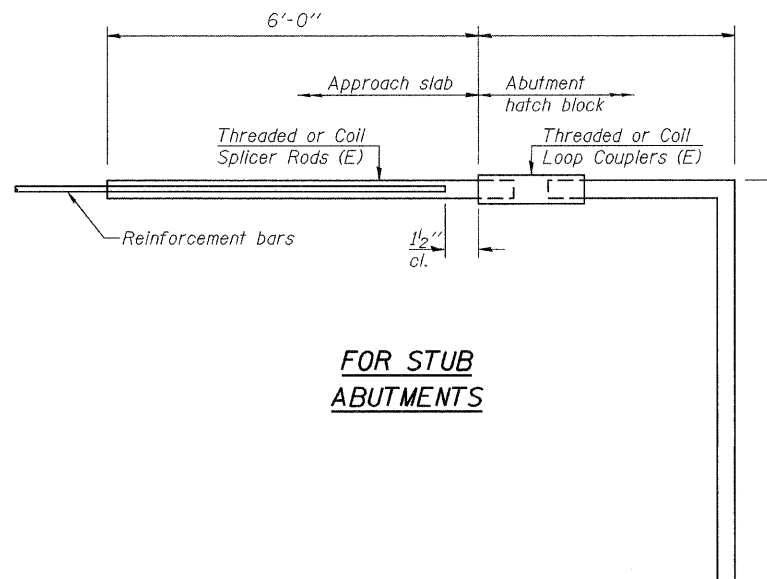

FOR STUB ABUTMENTS

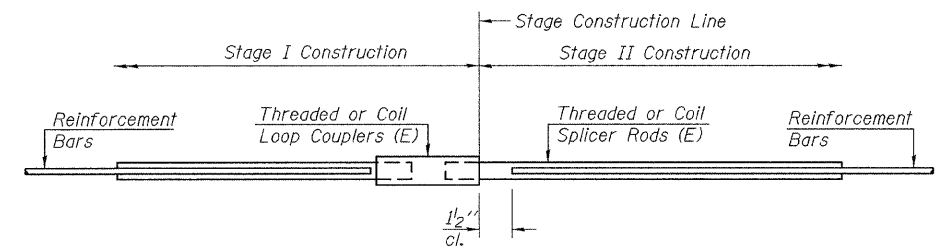

STANDARD

Bar Size	No. Assemblies Required	Location
#4	25	Stage Line (Top)
#5	42	Stage Line (Bott.)
#5	42	Appr. Footing

Bar Splicer for #5 bar
Min. Capacity = 23.0 kips - tension
Min. Pull-out Strength = 12.3 kips - tension
No. Required =

Bar Splicer for #5 bar
Min. Capacity = 23.0 kips - tension
Min. Pull-out Strength = 12.3 kips - tension
No. Required =

DESIGNED	VHV
CHECKED	DAB
DRAWN	Kyle M. Steffen
CHECKED	VHV DAB

OCTOBER 30, 2009

EXAMINED *A. Carl Poyser*
ENGINEER OF STRUCTURAL SERVICES

PASSED *Ralph E. Anderson*
ENGINEER OF BRIDGES AND STRUCTURES

BSD-1 10-1-08

BAR SPLICER ASSEMBLY DETAILS
SN 058-0095

SHEET NO. 21	F.A.I. RTE.	SECTION	COUNTY	TOTAL SHEETS	SHEET NO.
21 SHEETS	72	66(B,HVB,HB-1)BR	MACON	83	65
FED. ROAD DIST. NO.			ILLINOIS FED. AID PROJECT		
CONTRACT NO. 74343					

GENERAL NOTES

Reinforcement bars shall conform to the requirements of ASTM A 706 Br 60 (IL Modified). See Special Provisions.

Reinforcement bars designated (E) shall be epoxy coated.

Plan dimensions and details relative to existing plans are subject to routine variations. The Contractor shall field verify existing dimensions and details affecting new construction and make necessary approved adjustments prior to construction or ordering of materials. Such variations shall not be cause for additional compensations for a change in scope of the work; however, the Contractor will be paid for the quantity actually furnished based upon the unit price bid for the work.

Existing reinforcement bars extending into the removal area shall be cleaned, straightened and incorporated into the new construction. Any reinforcement bars that are damaged during concrete removal operations shall be repaired or replaced using an approved bar splicer or anchorage system. Cost included in concrete removal.

Joint openings shall be adjusted according to Article 520.04 of the Standard Specifications when the deck is poured at an ambient temperature other than 50°F.

Prior to pouring the new concrete deck, all heavy or loose rust, loose mill scale, and other loose or potentially detrimental foreign material shall be removed from the surfaces in contact with concrete. Tightly adhered paint may remain unless otherwise noted. Removal shall be accomplished by methods that will not damage the steel and the cost will be included in the pay item covering removal of the existing concrete.

Removal and replacement of the end handrail sections and support posts at the east abutment will be necessary for construction of the expansion joints. The existing handrail sections and support posts shall be reused. New bolts, shim plates, and post support anchor assemblies as detailed in the plans are to be provided and installed for the replacement of the handrail and supports. This work and all materials shall be included in the contract unit price for Concrete Superstructure.

Areas of deck repairs shown are estimated. The Engineer shall show actual locations of deck repairs on as-built plans.

The existing waterproofing membrane system is not known to contain asbestos.

TOTAL BILL OF MATERIALS

SN 058-0097

ITEM DESCRIPTION	UNIT	QUANTITY
Concrete Removal	Cu. Yd.	12.0
Concrete Superstructure	Cu. Yd.	13.3
Reinforcement Bars, Epoxy Coated	Pound	3010
Bar Splicers	Each	24
Elastomeric Bearing Assembly Type II	Each	8
Furnishing and Erecting Structural Steel	Pound	1900
Jack and Remove Existing Bearings	Each	8
Hot-Mix Asphalt Removal (Deck)	Sq. Yd.	899
Bridge Deck Hydro-Scarification, 1/2"	Sq. Yd.	899
Bridge Deck Fly Ash or GGBF Slag Concrete Overlay, 2/4"	Sq. Yd.	899
Bridge Deck Grooving	Sq. Yd.	899
Protective Coat	Sq. Yd.	899
Deck Slab Repair (Full Depth Type I)	Sq. Yd.	4
Deck Slab Repair (Full Depth Type II)	Sq. Yd.	31
Floor Drains	Each	16
Preformed Joint Strip Seal	Foot	82
Structural Repair of Concrete <5"	Sq. Ft.	141
Plug Existing Deck Drains	Each	16
Anchor Bolts 1/2" Ø	Each	16
Protective Shield	Sq. Yd.	1036



Expires Nov. 30, 2010

FILE NAME = c:\px_work\PWIDOT\SWARTZR\des37779\k...enbridge.dgn	USER NAME = swartzr	DESIGNED -	REVISED -	STATE OF ILLINOIS DEPARTMENT OF TRANSPORTATION	BRIDGE GENERAL NOTES & BILL OF MATERIALS SN 058-0097			F.A.I. RTE. 72	SECTION 66(B,HVB,HB-1)BR	COUNTY MACON	TOTAL SHEETS 83	SHEET NO. 66
PLOT SCALE = 20,0000' / IN.	PLOT DATE = 9/28/2009	DRAWN -	REVISED -		SCALE: N/A	SHEET NO. 1 OF 17 SHEETS	STA.	TO STA.	CONTRACT NO. 74343			
		CHECKED -	REVISED -		FED. ROAD DIST. NO. ILLINOIS FED. AID PROJECT							
		DATE -	REVISED -									

The existing 2 span steel mult-beam structure was constructed in 1974 as section 58-66HB-1 at sta. 854+91.19. SN 058-0097 carries CH-18 over FAI-72. The proposed project consists of new expansion joints, partial and full depth deck patching, new wearing surface, new deck drains, remove and replace bearings at abutments, and structural repair of concrete.

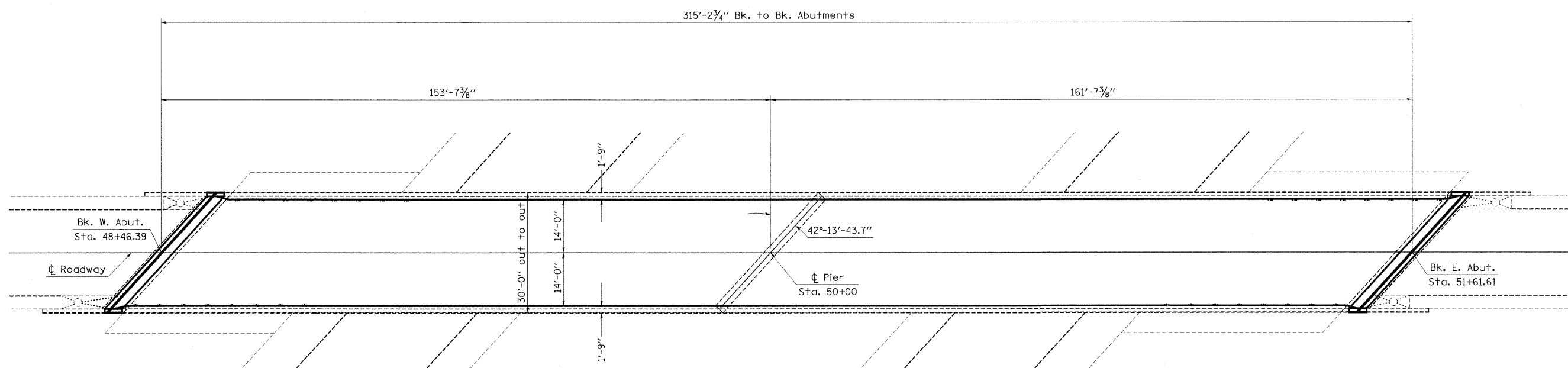
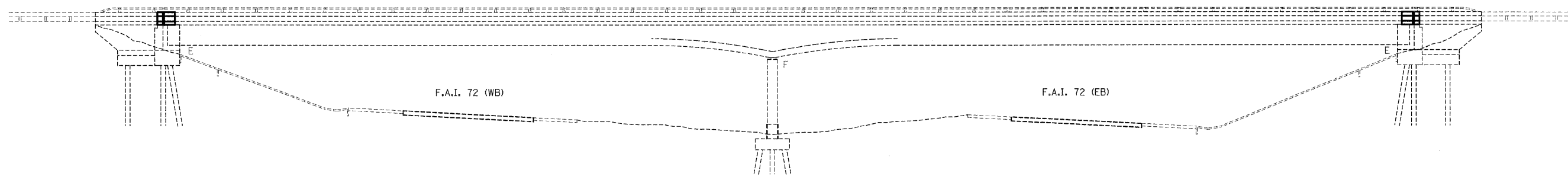

FILE NAME =	USER NAME = swartzrw	DESIGNED -	REVISED -	STATE OF ILLINOIS DEPARTMENT OF TRANSPORTATION	GENERAL PLAN & ELEVATION SN 058-0097			F.A.I. RTE.	SECTION	COUNTY	TOTAL SHEETS	SHEET NO.	
c:\pwork\p1000\SWARTZRW\dms37779\k...enbridge.dgn		DRAWN -	REVISED -		SCALE: N/A	SHEET NO. 2 OF 17 SHEETS	STA.	TO STA.	72	66(B,HVB,HB-1)BR	MACON	83	67
	PLOT SCALE = 20.0000' / IN.	CHECKED -	REVISED -					CONTRACT NO. 74343					
	PLOT DATE = 9/28/2009	DATE -	REVISED -					FED. ROAD DIST. NO. ILLINOIS FED. AID PROJECT					

Note: Trim existing long. reinf. to accommodate new joint opening (typ.)

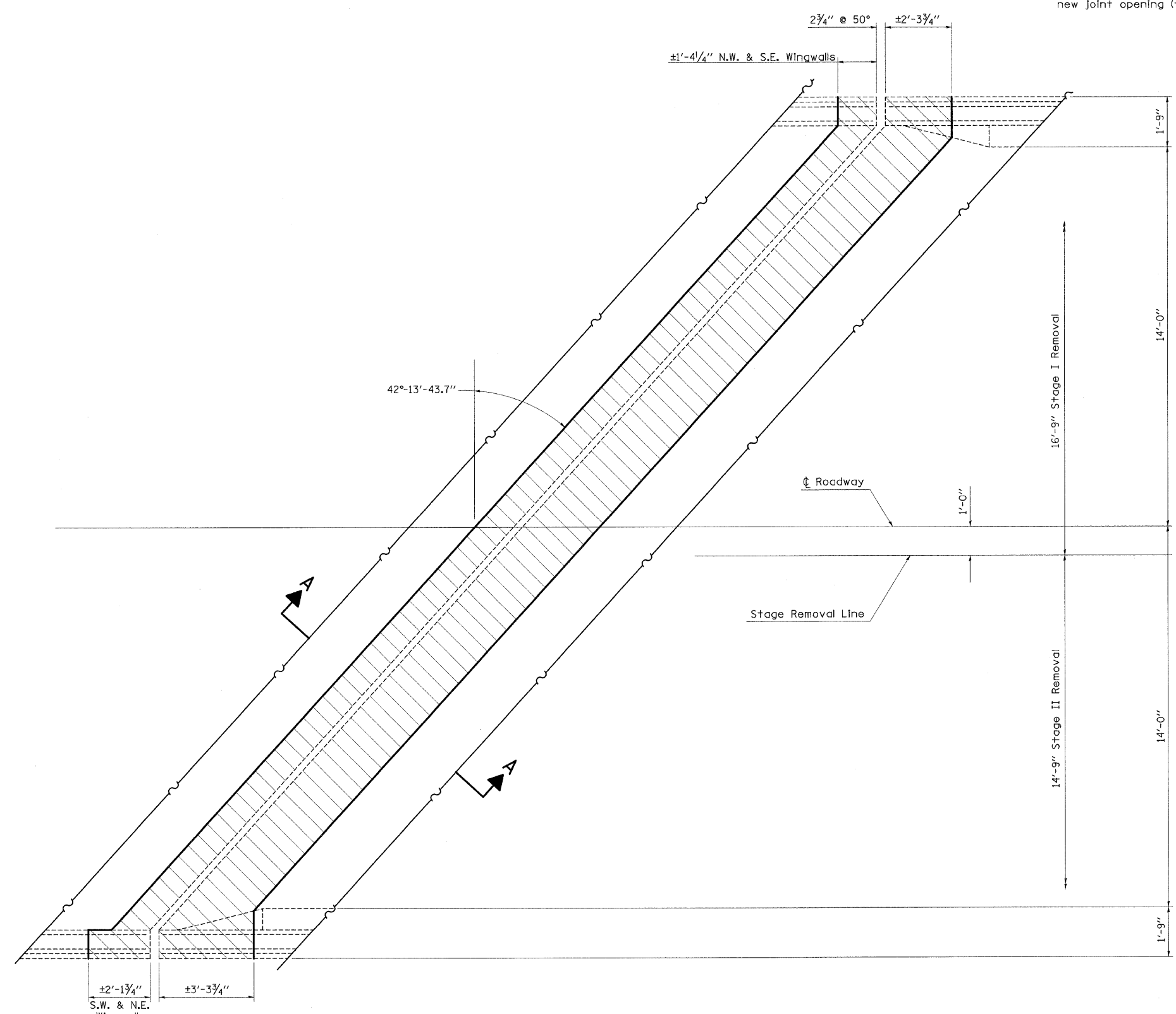

EXISTING PARTIAL PLAN
(West Abutment shown; East Abutment similar)

FILE NAME =	USER NAME = swartzw	DESIGNED -	REVISED -	STATE OF ILLINOIS DEPARTMENT OF TRANSPORTATION	EXPANSION JOINT REPLACEMENT DETAILS SN 058-0097			F.A.I. RTE.	SECTION	COUNTY	TOTAL SHEETS	SHEET NO.
c:\pwork\PWIDOT\SWARTZRW\dms37779\k... enbridge.dgn	DRAWN -	REVISED -	72					66(B,HVB,HB-1)BR	MACON	83	68	
PLOT SCALE = 20.0000 ' / IN.	CHECKED -	REVISED -	CONTRACT NO. 74343									
PLOT DATE = 9/28/2009	DATE -	REVISED -	SCALE: N/A		SHEET NO. 3 OF 17 SHEETS	STA.	TO STA.	FED. ROAD DIST. NO.	ILLINOIS FED. AID PROJECT			

BILL OF MATERIAL

BAR	NUMBER OF BARS		TOTAL	SIZE	LENGTH	SHAPE
	STAGE I	STAGE II				
a6(E)	16	16	32	#5	20'-7"	—
a7(E)	6	6	12	#6	4'-0"	—
d2(E)	2	2	4	#4	2'-1"	□
d6(E)	7	7	14	#4	4'-2"	J
d7(E)	7	7	14	#5	4'-0"	J
h4(E)	8	8	16	#6	19'-3"	—
x3(E)	38	38	72	#5	23'-3"	└

CONCRETE REMOVAL CU. YD. 12.0

REINFORCEMENT BARS (EPOXY COATED) POUND 3010

CONCRETE SUPERSTRUCTURE CU. YD. 13.3

REINFORCEMENT BARS DESIGNATED (E) SHALL BE EPOXY COATED

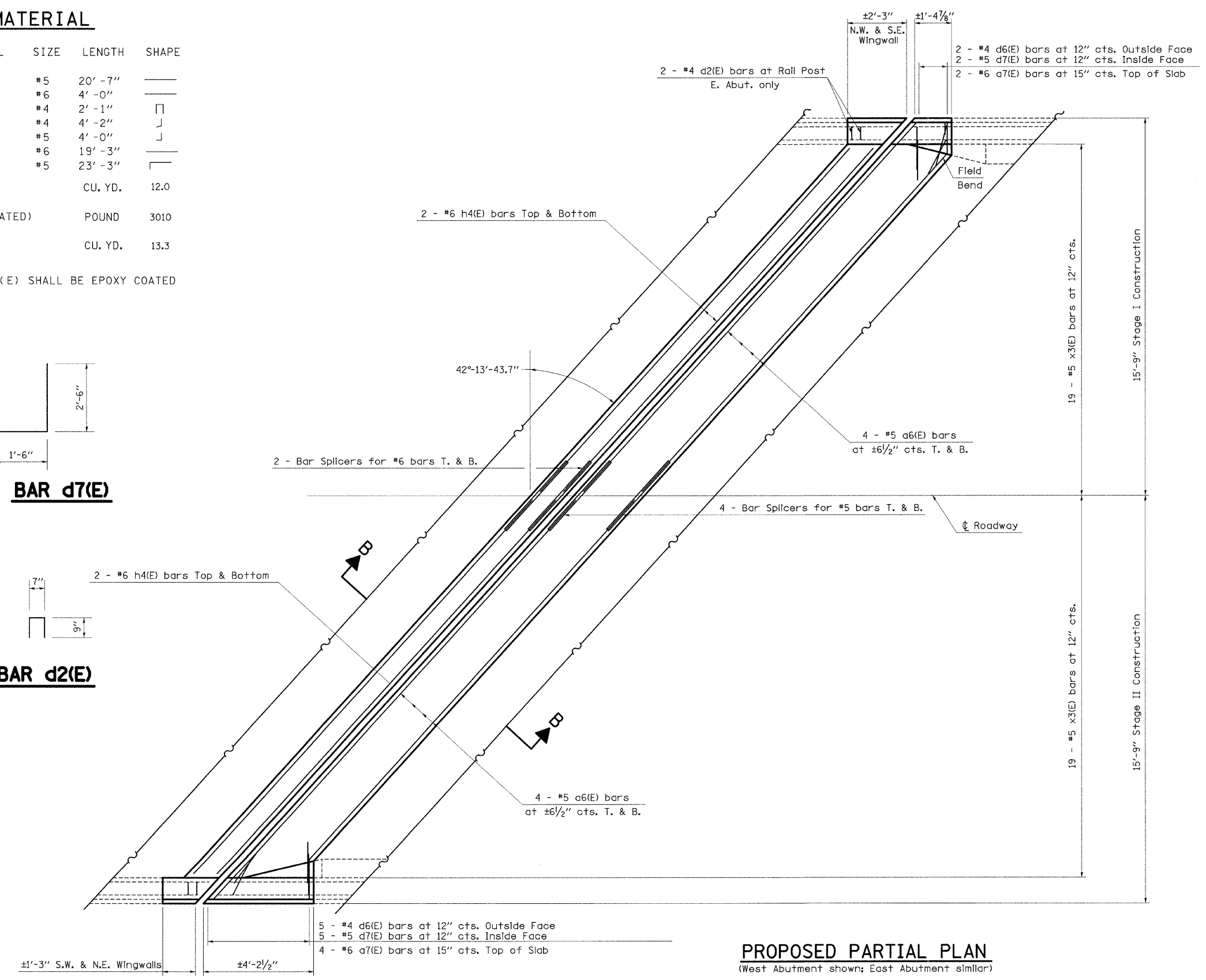
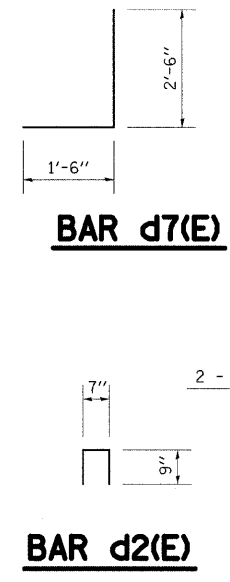
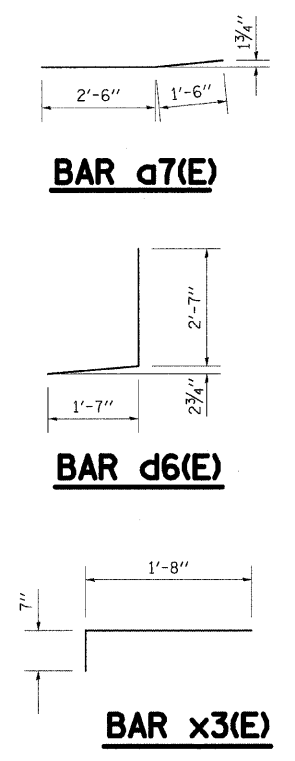

PROPOSED PARTIAL PLAN
(West Abutment shown; East Abutment similar)

FILE NAME =	USER NAME = swartzw	DESIGNED -	REVISED -	STATE OF ILLINOIS DEPARTMENT OF TRANSPORTATION	EXPANSION JOINT REPLACEMENT DETAILS SN 058-0097			F.A.I. RTE.	SECTION	COUNTY	TOTAL SHEETS	SHEET NO.
ct:\px_work\PWIDOT\SWARTZRW\dms37779\k... enbridge.dgn		DRAWN -	REVISED -					72	66(B,HVB,HB-1)BR	MACON	83	69
PLOT SCALE = 20.0000' / IN.		CHECKED -	REVISED -					CONTRACT NO. 74343				
PLOT DATE = 9/26/2009		DATE -	REVISED -					ILLINOIS FED. AID PROJECT				
				SCALE: N/A	SHEET NO. 4 OF 17 SHEETS	STA.	TO STA.					

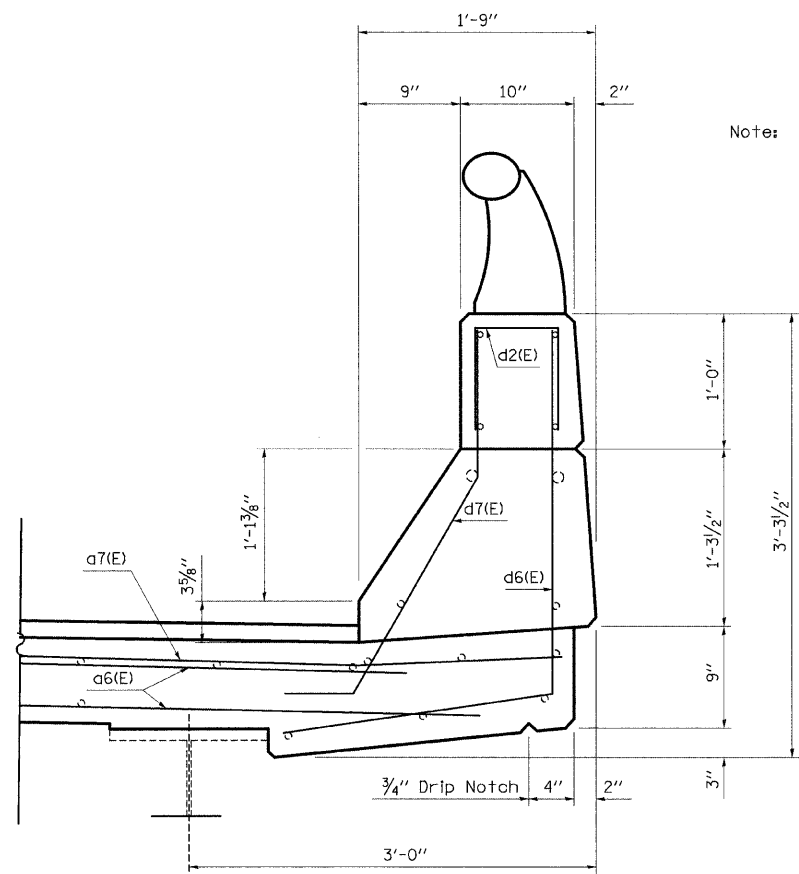

SECTION THRU PARAPET

Note: Rotate d6(E) and d7(E) bars in parapet to fit horizontal legs in concrete pour.

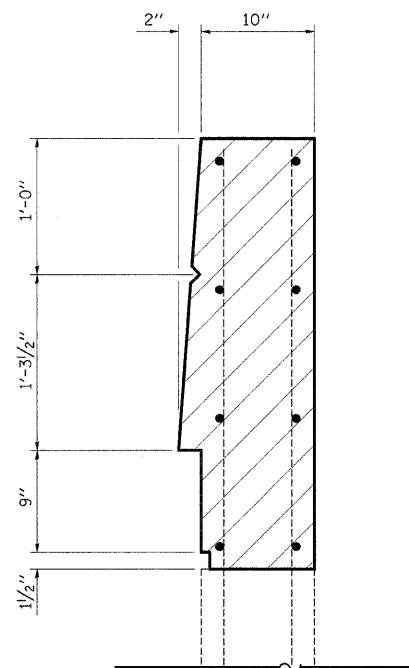

SECTION THRU WINGWALL

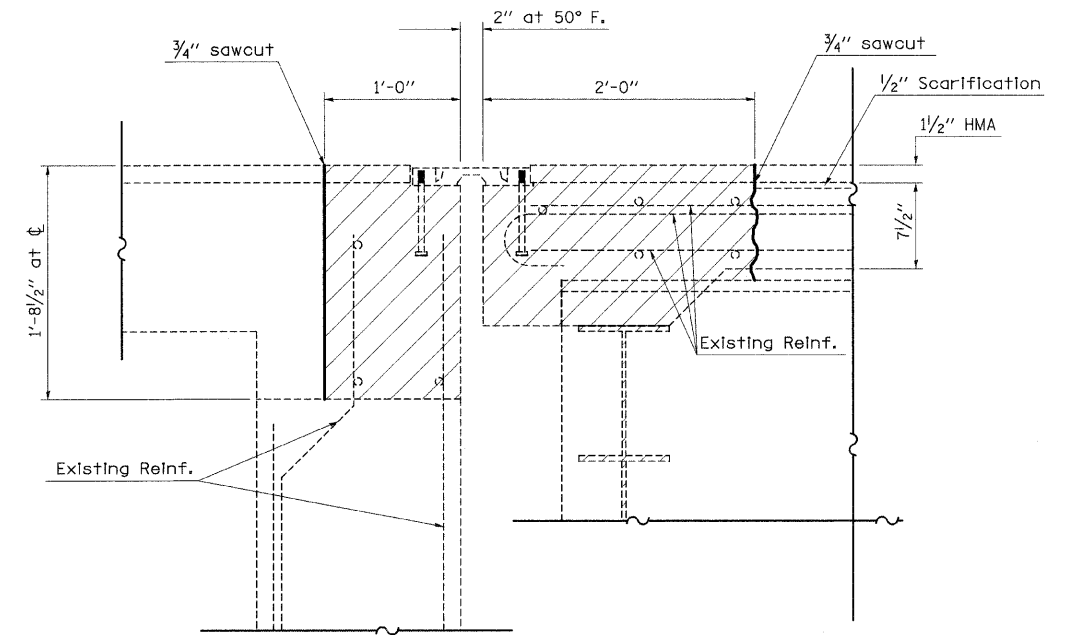

SECTION A-A
(Dimensions at RT L's to end of deck)

For details of expansion joint See sheet 51 of 52

- Existing Reinforcement
- Proposed Reinforcement

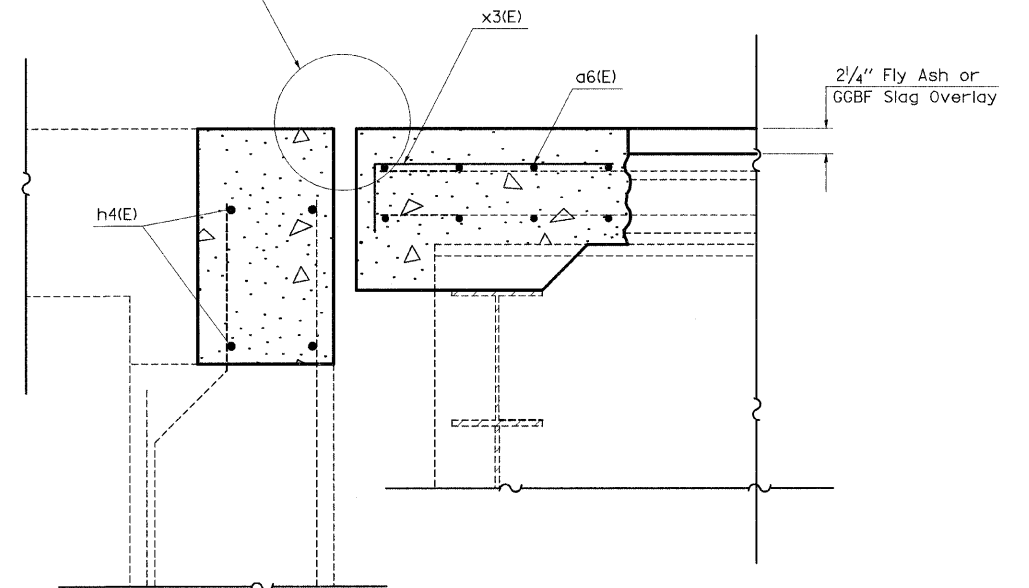

SECTION B-B
(Dimensions at RT L's to end of deck)

FILE NAME = c:\pw\work\PWIDOT\SWARTZRW\dms37779\k...enbridge.dgn	USER NAME = swartzrw	DESIGNED -	REVISED -	STATE OF ILLINOIS DEPARTMENT OF TRANSPORTATION	RAIL SUPPORT ANCHOR DETAILS		F.A.I. RTE. 72	SECTION 66(B,HVB,HB-1)BR	COUNTY MACON	TOTAL SHEETS 83	SHEET NO. 70	
PLOT SCALE = 20,0000' / IN.	PLOT DATE = 9/28/2009	DRAWN -	REVISED -		SCALE: N/A	SHEET NO. 5 OF 17 SHEETS	STA. TO STA.	CONTRACT NO. 74343				
		CHECKED -	REVISED -		FED. ROAD DIST. NO. ILLINOIS FED. AID PROJECT							
		DATE -	REVISED -									

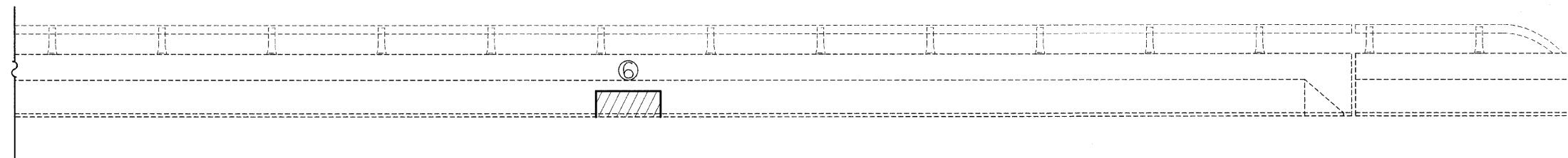
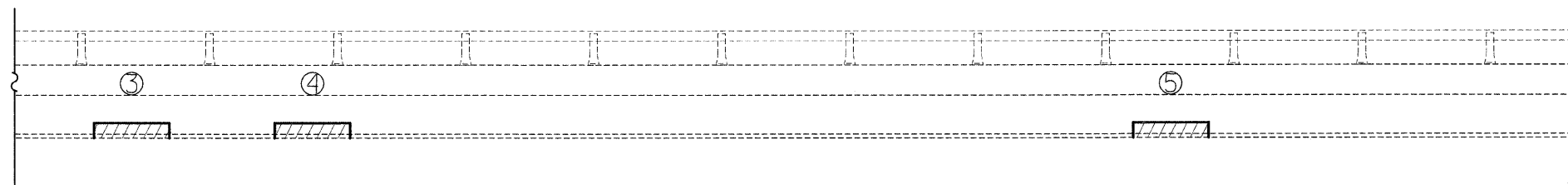
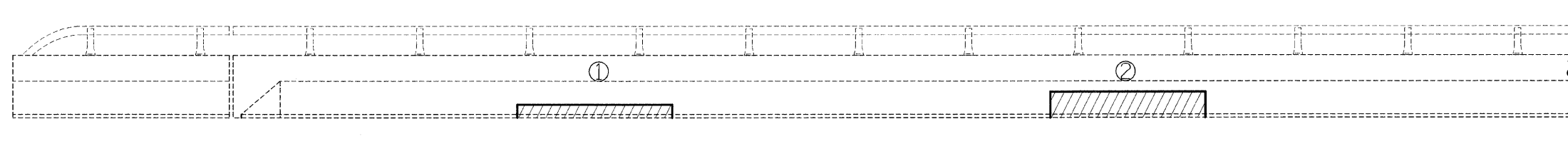

STRUCTURAL REPAIR

Cost Included in Structural Repair
of Concrete (Depth <5')

PATCH NUMBER	STATION	AREA SQ FT
1	48+80	6.0
2	49+34	12.0
3	49+73	3.0
4	49+85	3.0
5	50+42	3.0
6	51+17	5.0
	Total	32.0

NORTH PARAPET

Looking North

FILE NAME = c:\pwwork\p1001\SWARTZRW\dms37779\k...enbridge.dgn	USER NAME = swartzrw	DESIGNED -	REVISED -	STATE OF ILLINOIS DEPARTMENT OF TRANSPORTATION	STRUCTURAL REPAIR - PARAPET SN 058-0097			F.A.I. RTE.	SECTION	COUNTY	TOTAL SHEETS	SHEET NO.	
	PLOT SCALE = 20.0000' / IN.	DRAWN -	REVISED -		SCALE: N/A	SHEET NO. 6 OF 17 SHEETS	STA.	TO STA.	72	66(B,HV8,HB-DBR	MACON	83	71
	PLOT DATE = 9/28/2009	CHECKED -	REVISED -					CONTRACT NO. 74343					
		DATE -	REVISED -					FED. ROAD DIST. NO. ILLINOIS FED. AID PROJECT					

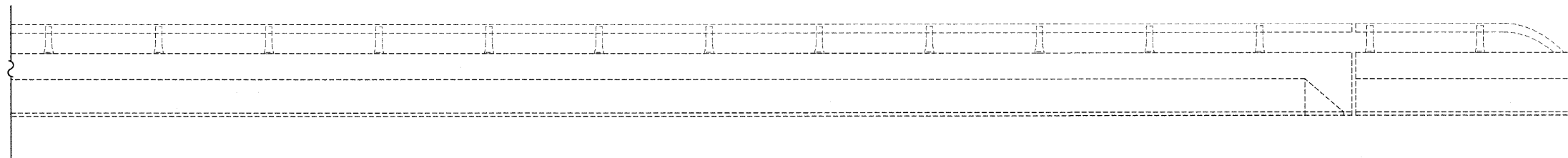
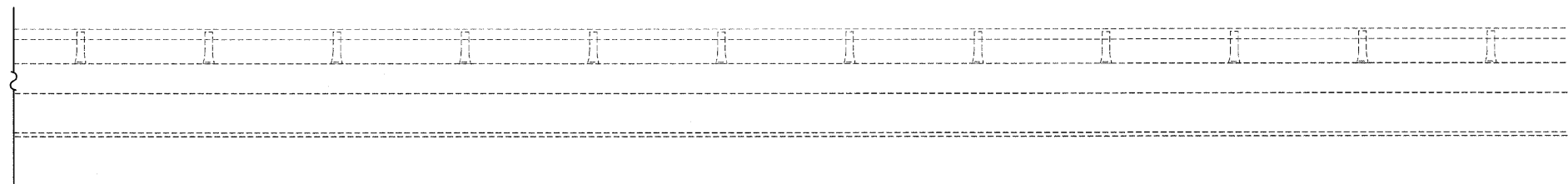
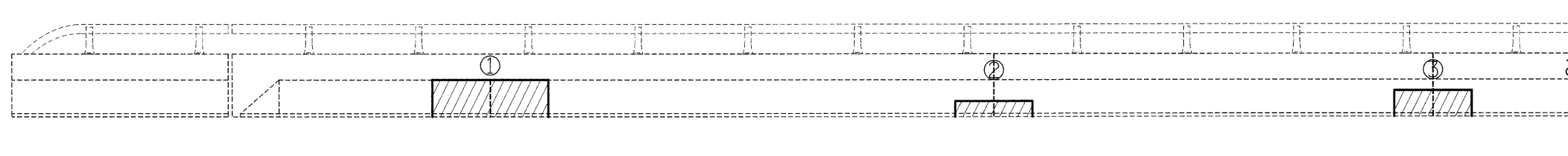

STRUCTURAL REPAIR

Cost Included in Structural Repair
of Concrete (Depth 45")

PATCH NUMBER	STATION	AREA SQ. FT.
1	51+27	14.0
2	50+88	4.0
3	50+54	6.0
	Total	24.0

SOUTH PARAPET

Looking South

NOTE: QUANTITIES ARE ESTIMATED. ACTUAL QUANTITIES TO BE DETERMINED BY THE RESIDENT ENGINEER.

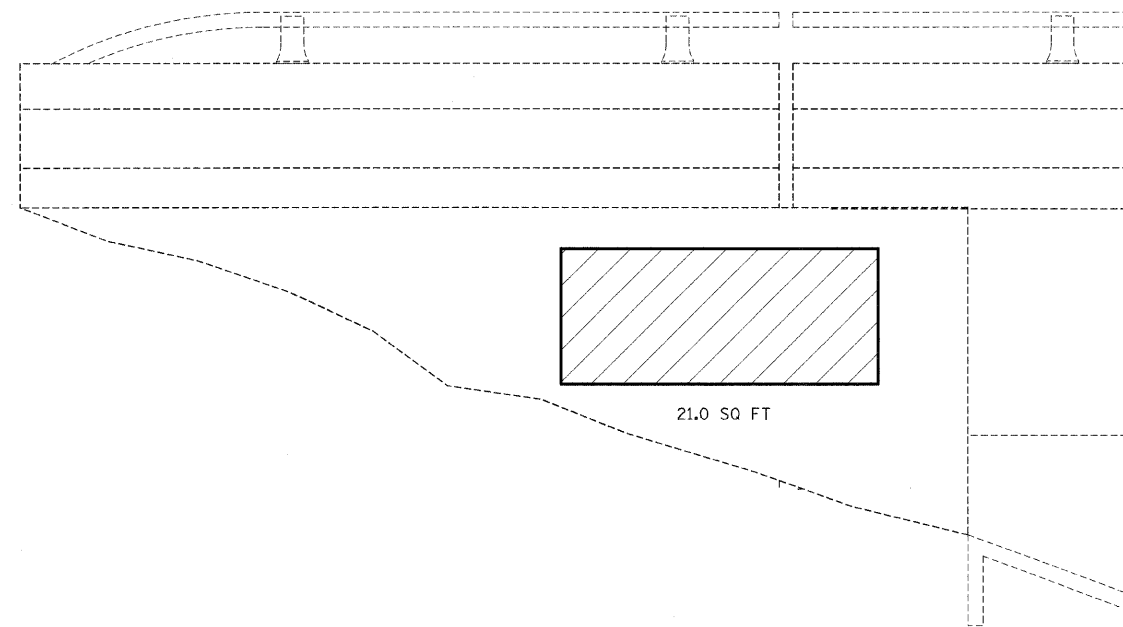

NORTHEAST WING

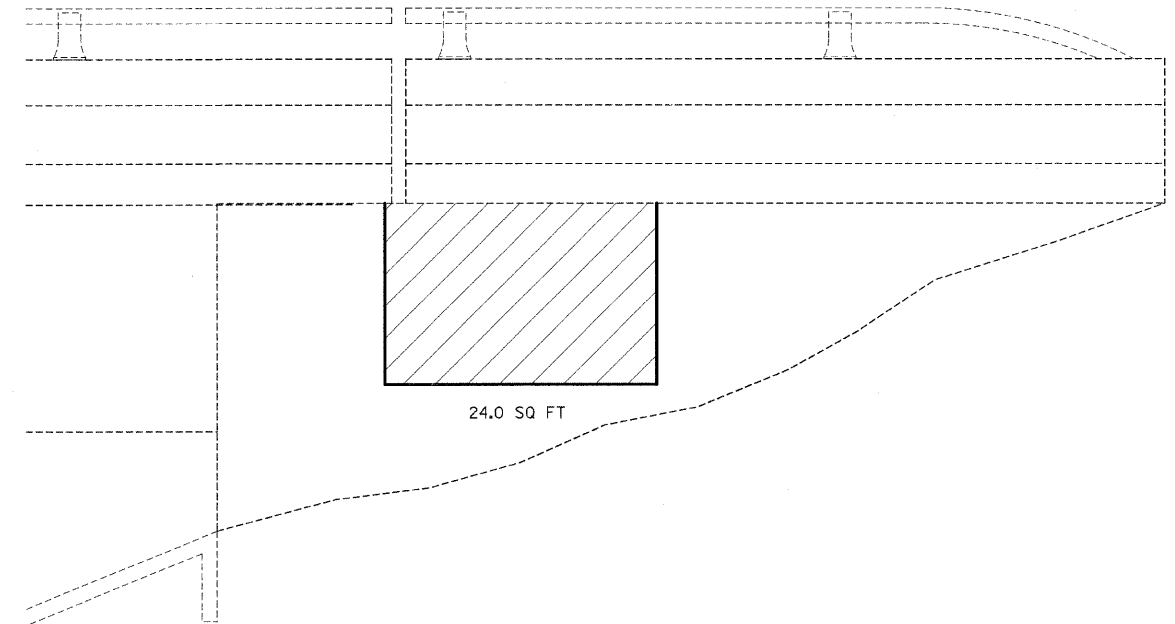

SOUTHEAST WING

 Structural Repair of Concrete (Depth < 5")

FILE NAME = c:\pwork\PWIDOT\SWARTZRW\dms37779\k...enbridge.dgn	USER NAME = swartzrw	DESIGNED -	REVISED -	STATE OF ILLINOIS DEPARTMENT OF TRANSPORTATION	STRUCTURAL REPAIR - EAST ABUTMENT SN 058-0097			F.A.I. RTE. 72	SECTION 66(B,HVB,HB-DBR)	COUNTY MACON	TOTAL SHEETS 83	SHEET NO. 73
PLLOT SCALE = 20.0000' / IN.	CHECKED -	REVISED -	REVISED -		SCALE: N/A			FED. ROAD DIST. NO.		ILLINOIS FED. AID PROJECT		
PLLOT DATE = 9/28/2009	DATE -	REVISED -	REVISED -		SHEET NO. 8 OF 17 SHEETS			STA.		TO STA.		
								CONTRACT NO. 74343				

NOTE: QUANTITIES ARE ESTIMATED. ACTUAL QUANTITIES TO BE DETERMINED BY THE RESIDENT ENGINEER.

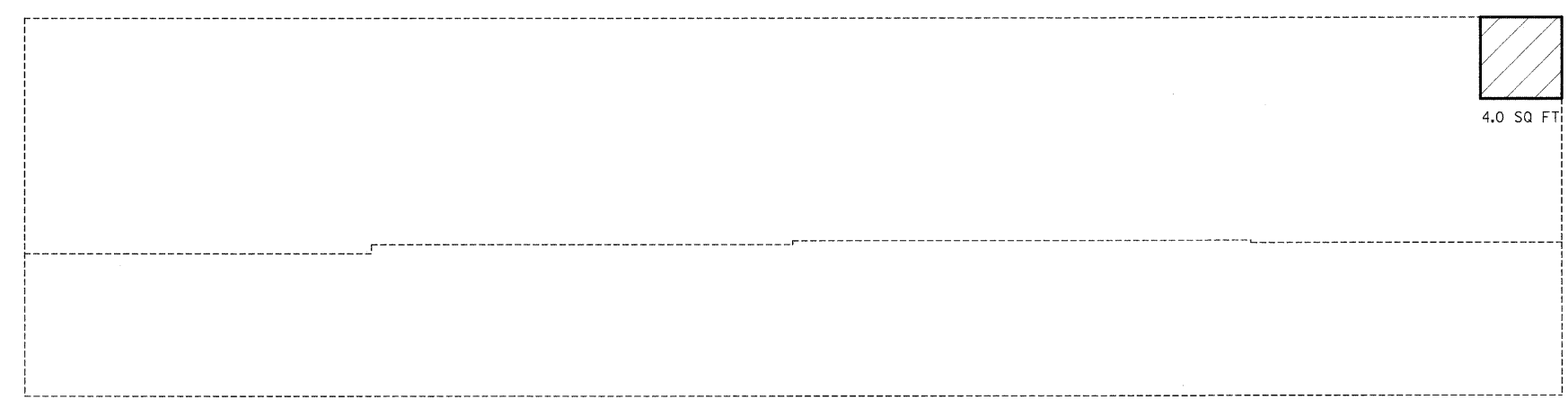
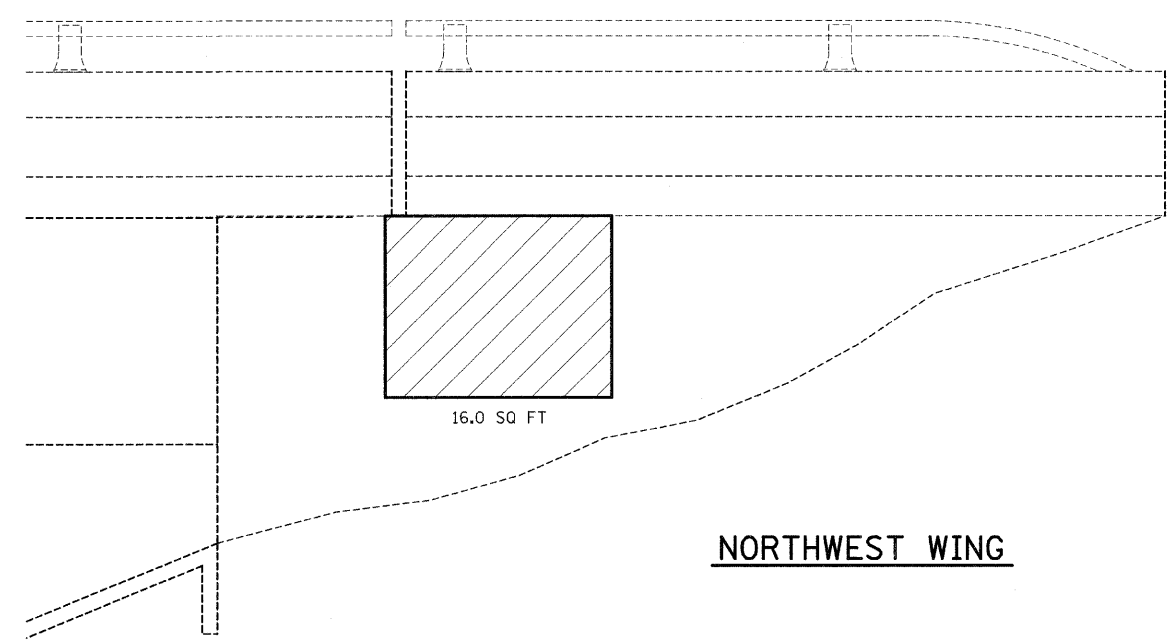
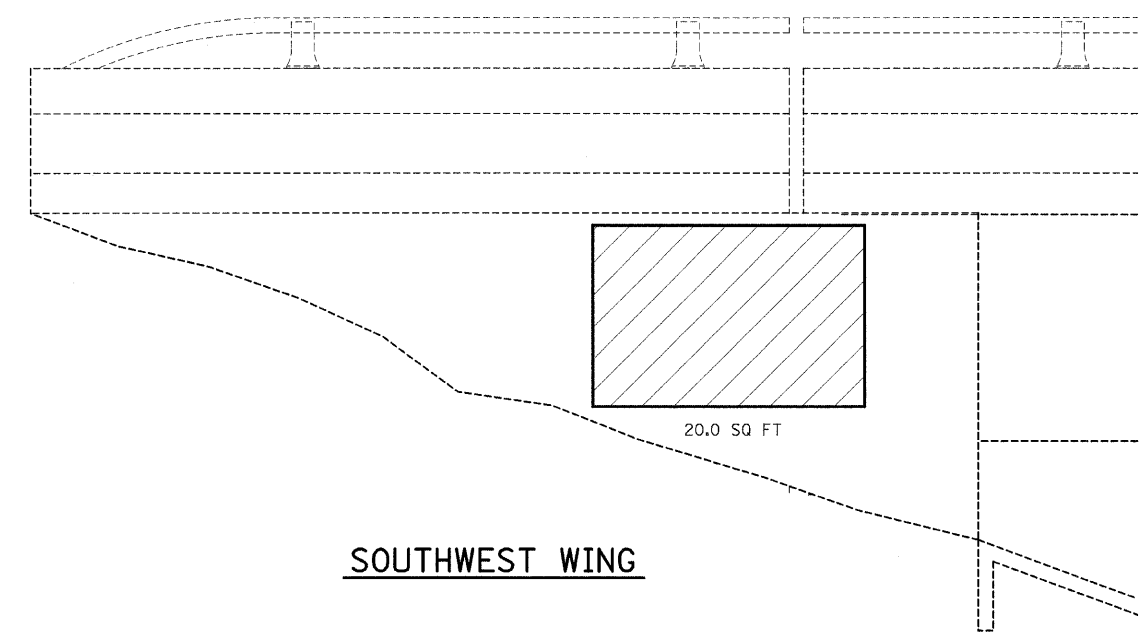

 Structural Repair of Concrete (Depth < 5")

FILE NAME = c:\pw\work\PWIDOT\SWARTZRW\dms37779\k...enbridge.dgn	USER NAME = swartzrw	DESIGNED -	REVISED -	STATE OF ILLINOIS DEPARTMENT OF TRANSPORTATION	STRUCTURAL REPAIR - WEST ABUTMENT SN 058-0097			F.A.I. RTE. 72	SECTION 66(B,HVB,HB-1BR)	COUNTY MACON	TOTAL SHEETS 83	SHEET NO. 74
PLOT SCALE = 20.0000' / IN.		DRAWN -	REVISED -		SCALE: N/A	SHEET NO. 9 OF 17 SHEETS	STA.	TO STA.	CONTRACT NO. 74343			
PLOT DATE = 9/28/2009		CHECKED -	REVISED -		FED. ROAD DIST. NO. ILLINOIS FED. AID PROJECT							
		DATE -	REVISED -									

* Dimension as required by Pipe Clamp

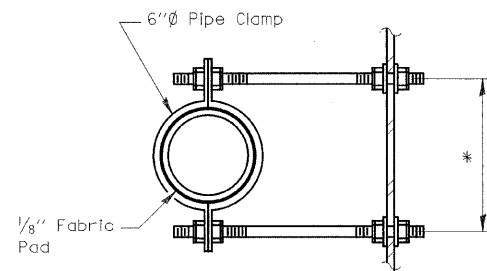

SECTION A-A

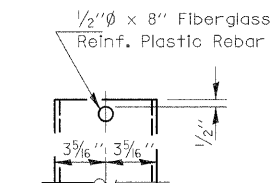

FIBERGLASS PIPE

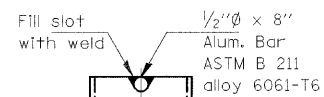

ALUMINUM TUBE

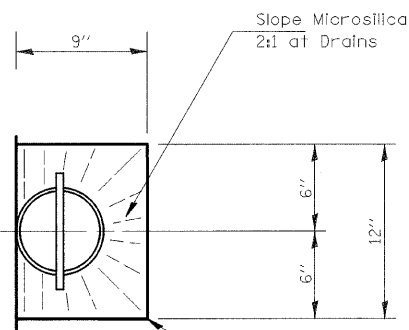

TOP PLAN

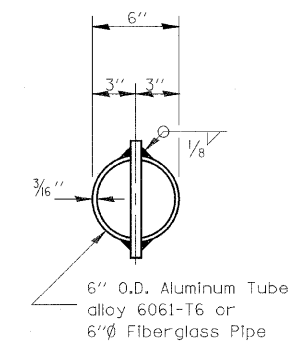

TOP PLAN

(Showing Aluminum Tube)

Note:
Fiberglass pipe shall conform to ASTM D 2996, with short-time rupture strength hoop tensile stress of 30,000 p.s.i. minimum.

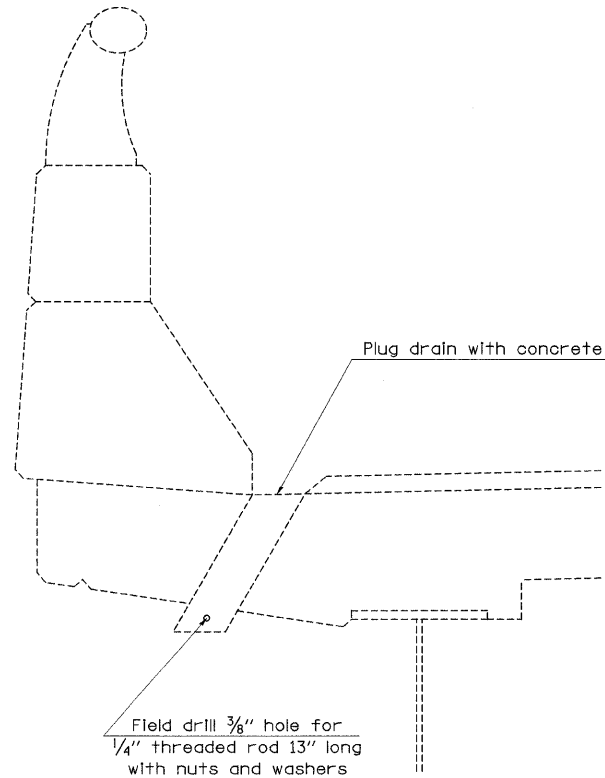

DRAINS TO BE PLUGGED DETAIL

Note: See "Bridge Deck Patching" plan sheets for Plug Existing Deck Drains locations. See "Total Bill of Materials" for each structure for quantities.

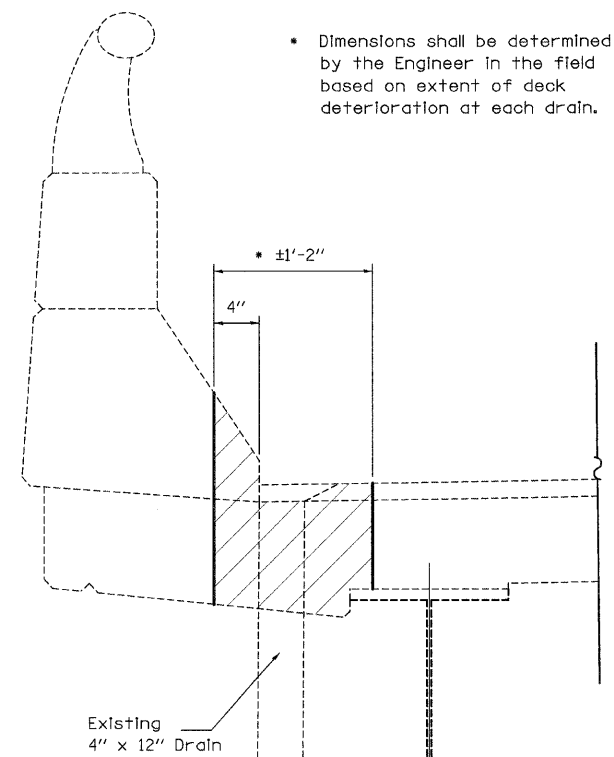

SECTION THRU EXISTING FLOOR DRAIN

Hatched area indicates concrete removal at floor drain replacement.

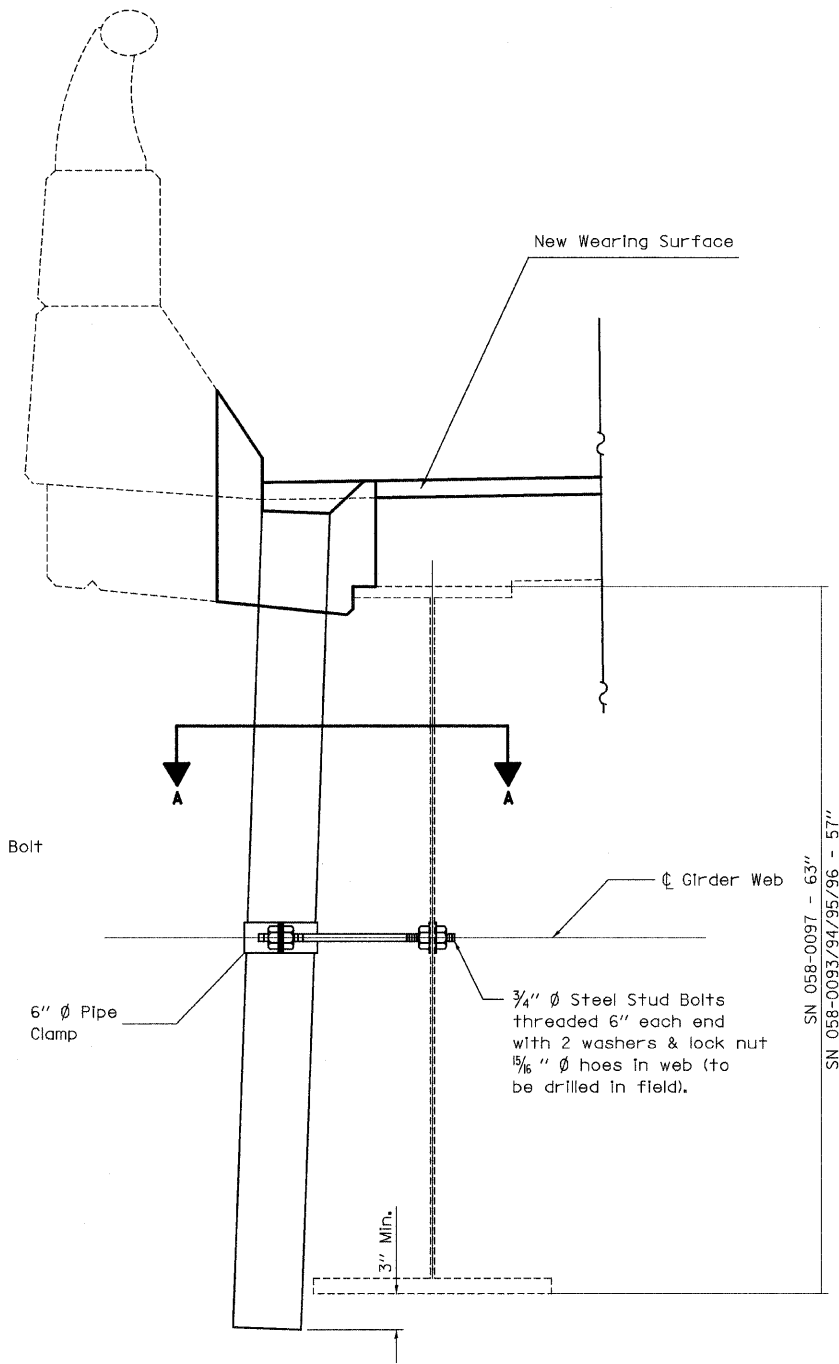

DRAIN REPLACEMENT DETAIL

Note: See "Bridge Deck Patching" plan sheets for Floor Drain replacement locations. See "Total Bill of Materials" for each structure for quantities. Concrete removal and replacement shall be paid for as DECK SLAB REPAIR (FULL DEPTH).

FILE NAME = c:\pwwork\pwwid01\SWARTZRW\dms37779\k...enbridge.dgn	USER NAME = swartzrw	DESIGNED -	REVISED -	STATE OF ILLINOIS DEPARTMENT OF TRANSPORTATION	FLOOR DRAIN DETAIL		F.A.I. RTE. 72	SECTION 66(B,HV8,HB-1)BR	COUNTY MACON	TOTAL SHEETS 83	SHEET NO. 75	
PLOT SCALE = 20,0000' / IN.		CHECKED -	REVISED -		SCALE: N/A	SHEET NO. 10 OF 17 SHEETS	STA. TO STA.	CONTRACT NO. 74343		ILLINOIS FED. AID PROJECT		
PLOT DATE = 9/28/2009		DATE -	REVISED -									
SN 058-0097 - 63" SN 058-0093/94/95/96 - 57"												

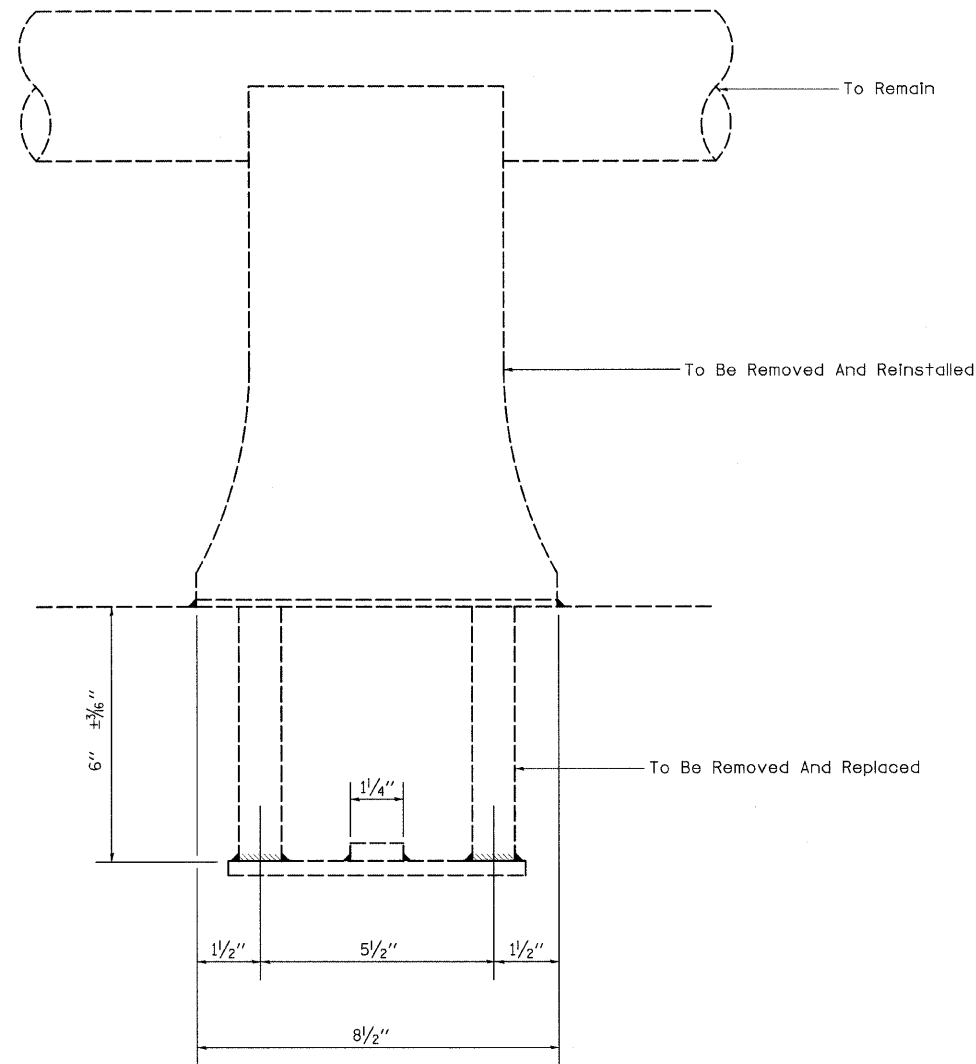

Note: Post anchorage supports are to be removed and replaced during construction. New bolts, shim plates, and post support anchor assemblies are to be provided.

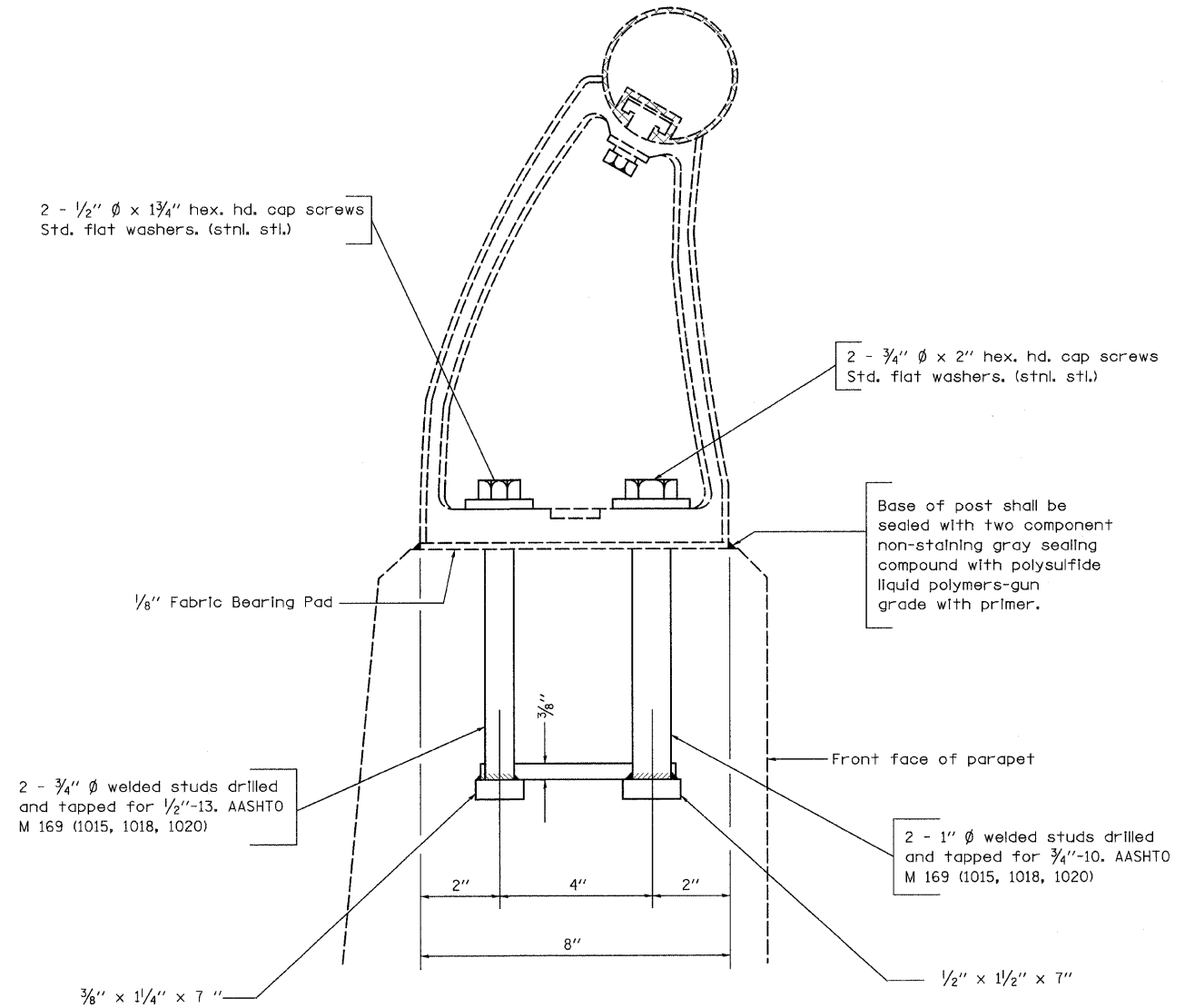

FILE NAME = c:\pw\work\PWIDOT\SWARTZRW\dms37779\k...enbridge.dgn	USER NAME = swartzrw	DESIGNED -	REVISED -	STATE OF ILLINOIS DEPARTMENT OF TRANSPORTATION	RAIL SUPPORT ANCHOR DETAILS		F.A.I. RTE. 72	SECTION 66(B,HVB,HB-1)BR	COUNTY MACON	TOTAL SHEETS 83	SHEET NO. 76	
PLOT SCALE = 20.0000' / IN.	CHECKED -	REVISED -	SCALE: N/A				SHEET NO. 11 OF 17 SHEETS	STA. TO STA.	FED. ROAD DIST. NO. ILLINOIS FED. AID PROJECT			
PLOT DATE = 9/28/2009	DATE -	REVISED -			CONTRACT NO. 74343							

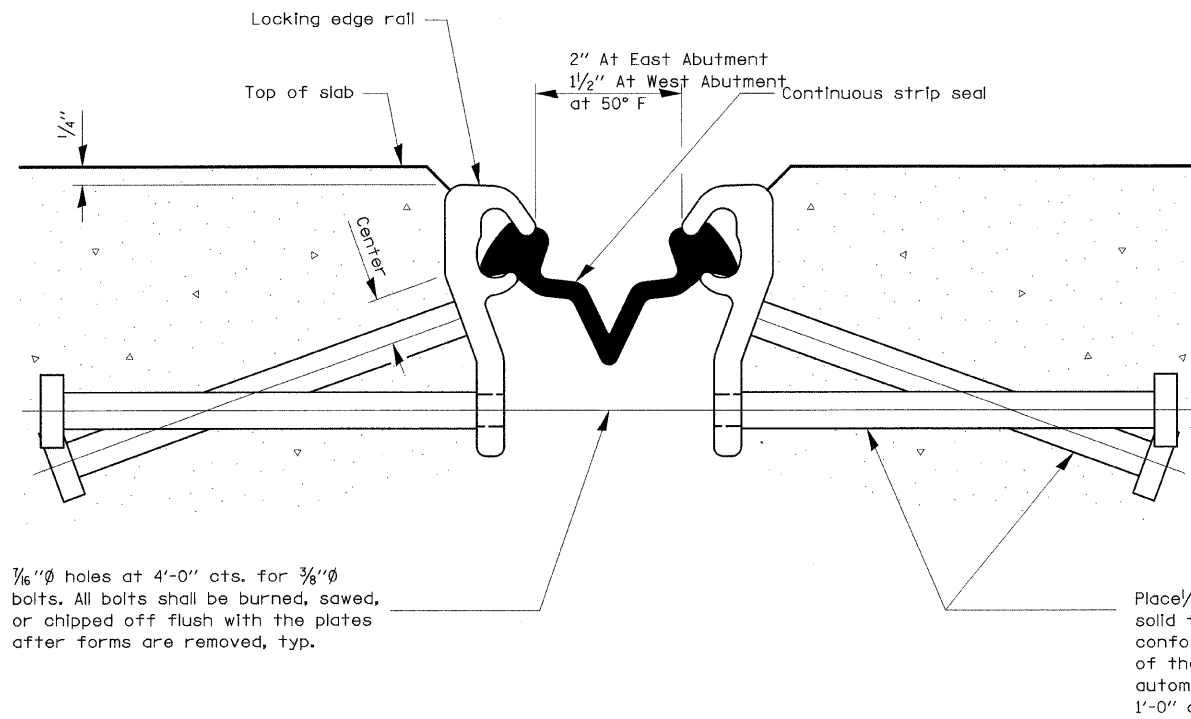

SECTION THRU STRIP SEAL JOINT

Notes:

The strip seal shall be made continuous and shall have a minimum thickness of 1/4". The configuration of the strip seal shall match the configuration of the Locking Edge Rails.

The height and thickness of the Locking Edge Rails shown are minimum dimensions. The actual configuration of the Locking Edge Rails and matching strip seal may vary from manufacturer to manufacturer. Flanged edge rails will not be allowed.

The inside of the Locking Edge Rail groove shall be free of weld residue.

Locking Edge Rails may be spliced at slope discontinuities and stage construction joints.

The manufacturer's recommended installation methods shall be followed.

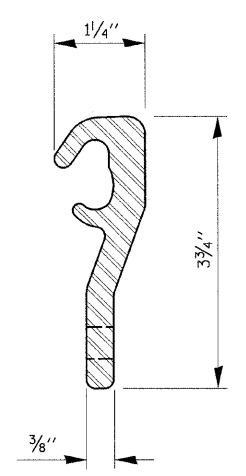

LOCKING EDGE RAIL

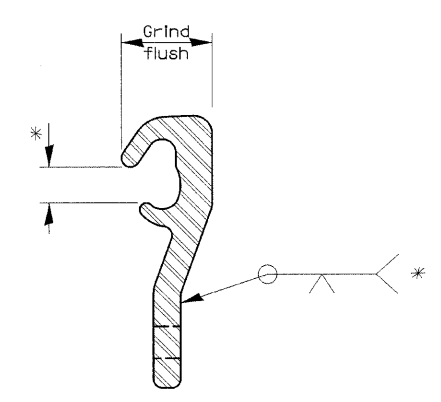

LOCKING EDGE RAIL SPLICE

• Omit weld at seal opening.

BILL OF MATERIAL

SN	Item	Unit	Total
058-0093	Preformed Joint Strip Seal	Foot	96'
058-0094	Preformed Joint Strip Seal	Foot	96'

FILE NAME =	USER NAME = swartzw	DESIGNED -	REVISED -	STATE OF ILLINOIS DEPARTMENT OF TRANSPORTATION	PREFORMED JOINT STRIP SEAL 058-0093 (EB) & 058-0094 (WB)	F.A.I. RTE.	SECTION	COUNTY	TOTAL SHEETS	SHEET NO.	
c:\pw_work\FWIDOT\SWARTZRW\dms37779\k	enbridge.dgn	DRAWN -	REVISED -			72	66(B,HVB,HB-1)BR	MACON	83	77	
	PLOT SCALE = 20,0000' / IN.	CHECKED -	REVISED -			SCALE: N/A		SHEET NO. 12 OF 17 SHEETS		STA. TO STA.	
	PLOT DATE = 9/28/2009	DATE -	REVISED -			FED. ROAD DIST. NO.		ILLINOIS FED. AID PROJECT			
						CONTRACT NO. 74343					

* Granular or solid flux filled headed studs conforming to Article 1006.32 of the Std. Specs., automatically end welded.

** When joint is fixed, dimension is set at 1 1/2".

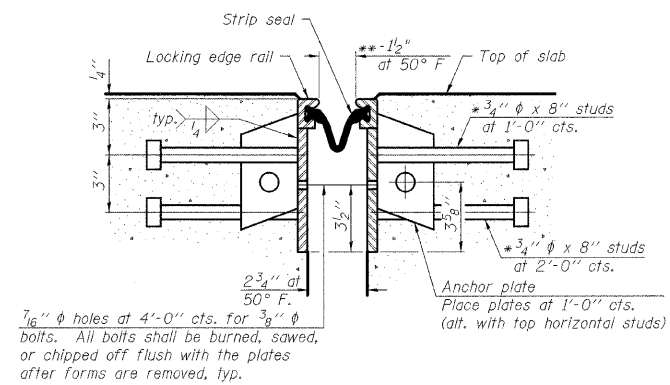
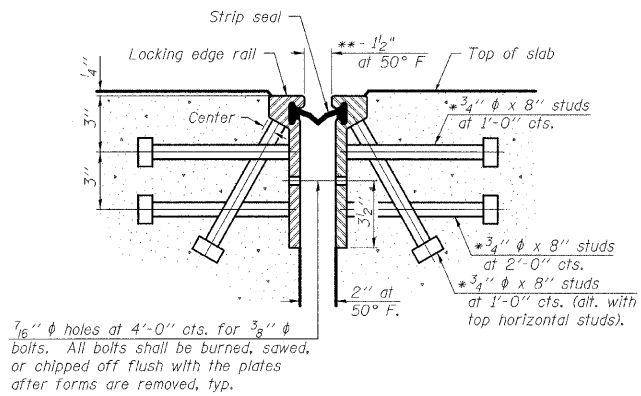

Notes:

The strip seal shall be made continuous and shall have a minimum thickness of 1/4". The configuration of the strip seal shall match the configuration of the Locking Edge Rails. Open or "webbed" strip seal gland configurations are not permitted. The gland shall be sized for a maximum rated movement of 4 inches. The height and thickness of the Locking Edge Rails shown are minimum dimensions. The actual configuration of the Locking Edge Rails and matching strip seal may vary from manufacturer to manufacturer. Flanged edge rails will not be allowed. Locking Edge Rails may be spliced at slope discontinuities and stage construction joints. The manufacturer's recommended installation methods shall be followed. The joint opening and deck dimensions detailed on the superstructure are based on a rolled rail expansion joint. If the Contractor elects to use the welded rail expansion joint, the opening and deck dimensions shall be modified according to the dimensions detailed on this sheet. Required modifications shall be made at no additional cost to the State. All steel components shall be galvanized after fabrication according to Article 520.03 of the Standard Specifications.

SECTION THRU ROLLED RAIL JOINT

SECTION THRU WELDED RAIL JOINT

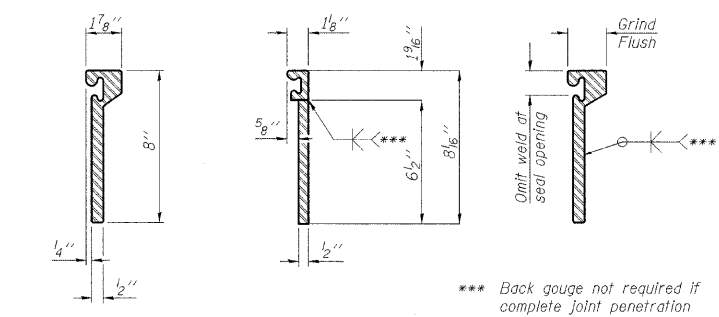

ROLLED (EXTRUDED) RAIL WELDED RAIL

*** Back gouge not required if complete joint penetration is verified by mock-up.

LOCKING EDGE RAIL SPLICE

The inside of the locking edge rail groove shall be free of weld residue.

LOCKING EDGE RAILS

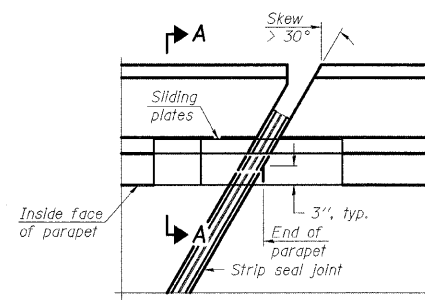

PLAN

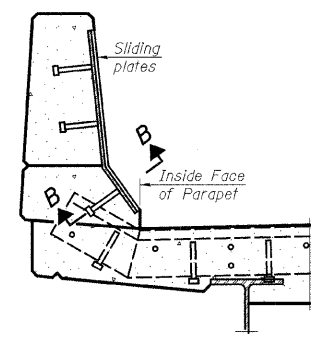

SECTION A-A

POINT BLOCK DETAILS (for skews > 30°)

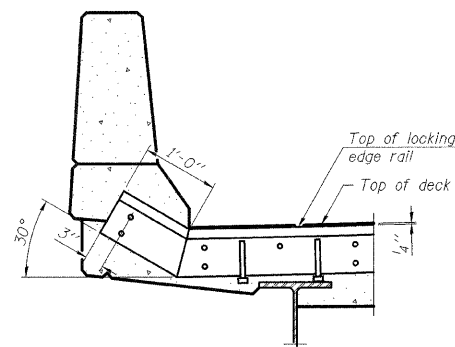

AT PARAPET

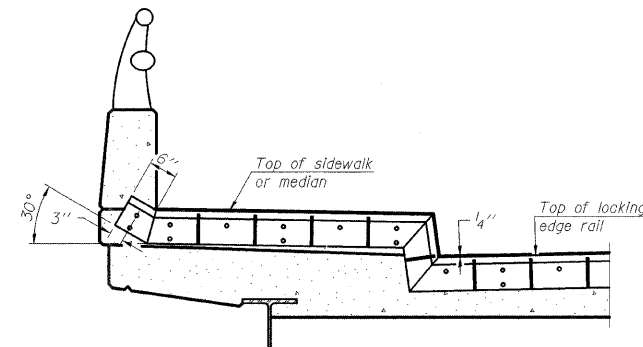

AT SIDEWALK OR MEDIAN

Shorter plates with a single row of studs at 12" cts. may be necessary on medians which are shallower than 9". See manufacturer's recommendation.

TYPICAL END TREATMENTS

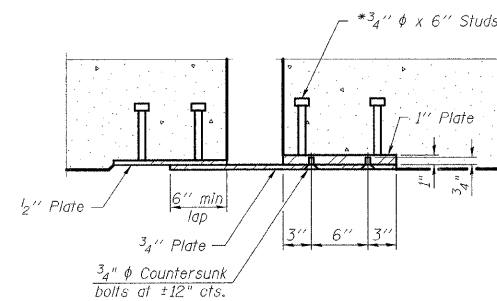

SECTION B-B

BILL OF MATERIAL

SN	Item	Unit	Total
058-0095	Preformed Joint Strip Seal	Foot	192'
058-0096	Preformed Joint Strip Seal	Foot	192'
058-0097	Preformed Joint Strip Seal	Foot	82'

PREFORMED JOINT STRIP SEAL

EJ-SSJ

11-1-06

FILE NAME =	USER NAME = swartzw	DESIGNED -	REVISED -
cs:\pw\work\PWIDOT\SWARTZR\dwg\37779\k...	enbridge.dgn	DRAWN -	REVISED -
	PLOT SCALE = 20,0000' / IN.	CHECKED -	REVISED -
	PLOT DATE = 9/28/2009	DATE -	REVISED -

**STATE OF ILLINOIS
DEPARTMENT OF TRANSPORTATION**

PREFORMED JOINT STRIP SEAL			
SN 058-0095 (EB) & SN 058-0096 (WB) & 058-0097			
SCALE: N/A	SHEET NO. 13 OF 17 SHEETS	STA.	TO STA.

F.A.I. RTE.	SECTION	COUNTY	TOTAL SHEETS	SHEET NO.
72	66(B,HVB,HB-1)BR	MACON	83	78
				CONTRACT NO. 74343
FED. ROAD DIST. NO. ILLINOIS FED. AID PROJECT				

The diameter of this part is equal or larger than the diameter of bar spliced.

The diameter of this part is the same as the diameter of the bar spliced.

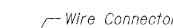
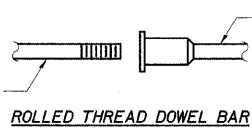

BAR SPLICER ASSEMBLY ALTERNATIVES

** Heavy Hex Nuts conforming to ASTM A 563, Grade C, D or DH may be used.

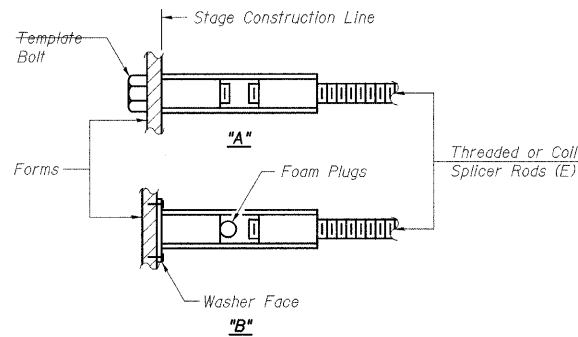

INSTALLATION AND SETTING METHODS

"A" : Set bar splicer assembly by means of a template bolt.
"B" : Set bar splicer assembly by nailing to wood forms or cementing to steel forms.
(E) : Indicates epoxy coating.

NOTES

Bar splicer assemblies shall be of an approved type and shall develop in tension at least 125 percent of the yield strength of the lapped reinforcement bars.
Splicer rods shall be of minimum 60 ksi yield strength, threaded or coiled full length.
All reinforcement bars shall be lapped and tied to the splicer rods or dowel bars.
Bar splicer assemblies shall be epoxy coated according to the requirements for reinforcement bars.
Other systems of similar design may be submitted to the Engineer for approval. Approval shall be based on certified test results from an approved testing laboratory that the proposed bar splicer assembly satisfies the following requirements:

- ① Minimum Capacity (Tension in kips) = $1.25 \times f_y \times A_1$
 - ② Minimum *Pull-out Strength (Tension in kips) = $0.66 \times f_y \times A_1$
- Where f_y = Yield strength of lapped reinforcement bars in ksi.
 A_1 = Tensile stress area of lapped reinforcement bars.
* = 28 day concrete

BAR SPLICER ASSEMBLIES			
Bar Size to be Spliced	Splicer Rod or Dowel Bar Length	Strength Requirements	
		Min. Capacity kips - tension	Min. Pull-Out Strength kips - tension
#4	1'-8"	14.7	7.9
#5	2'-0"	23.0	12.3
#6	2'-7"	33.1	17.4
#7	3'-5"	45.1	23.8
#8	4'-6"	58.9	31.3
#9	5'-9"	75.0	39.6
#10	7'-3"	95.0	50.3
#11	9'-0"	117.4	61.8

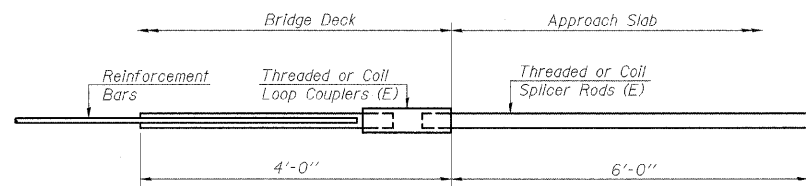

FOR INTEGRAL OR SEMI-INTEGRAL ABUTMENTS

Bar Splicer for #5 bar
Min. Capacity = 23.0 kips - tension
Min. Pull-out Strength = 12.3 kips - tension
No. Required =

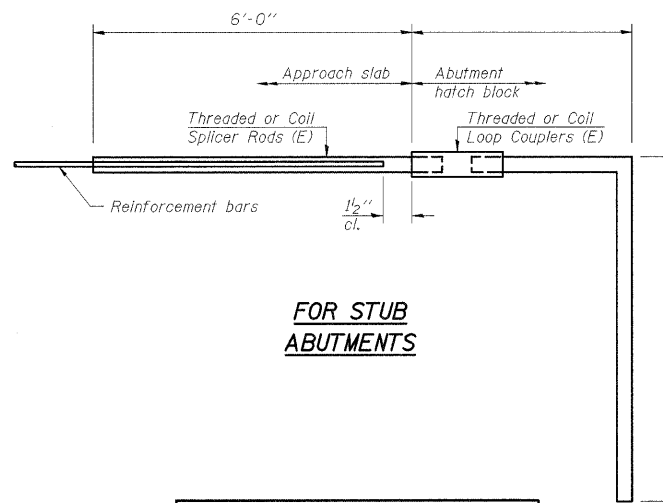

FOR STUB ABUTMENTS

Bar Splicer for #5 bar
Min. Capacity = 23.0 kips - tension
Min. Pull-out Strength = 12.3 kips - tension
No. Required =

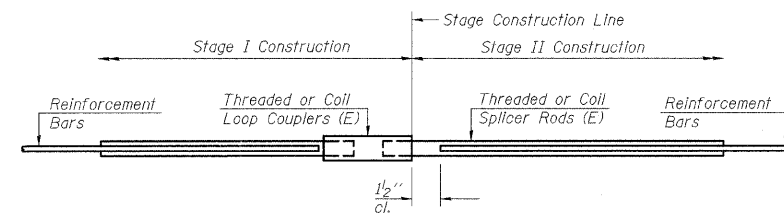

STANDARD

Bar Size	No. Assemblies Required	Location

BSD-1

11-1-06

BAR SPLICER ASSEMBLY DETAILS

STATE OF ILLINOIS
DEPARTMENT OF TRANSPORTATION

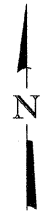

NOTES

All structural steel shall conform to AASHTO Classification M-270 Gr. 36, unless otherwise noted.

Plan dimensions and details relative to existing plans are subject to routine variations. The Contractor shall field verify existing dimensions and details affecting new construction and make necessary approved adjustments prior to construction or ordering of materials. Such variations shall not be cause for additional compensation for a change in scope of the work, however, the Contractor will be paid for the quantity actually furnished based upon the unit price bid for the work.

If the analysis submitted to the Contractor for the jacking/temporary support system to be used shows temporary stiffeners are required to prevent web crippling or buckling, the stiffeners shall be steel and bolted to the web. If stiffeners are not required, hardwood timbers shall be installed tightly between the top and bottom flange to prevent flange rotation.

The existing structural steel coating contains lead. The Contractor shall take appropriate precautions to deal with the presence of lead on this project.

Existing structural steel that will be in contact with new structural steel shall be cleaned and painted prior to erection as required by the Special Provision "Cleaning and Painting Contact Surface Areas of Existing Steel Structures".

All structural steel shall be shop painted with the inorganic zinc rich primer per AASHTO M300, Type 1. Cost included with Furnishing and Erecting Structural Steel.

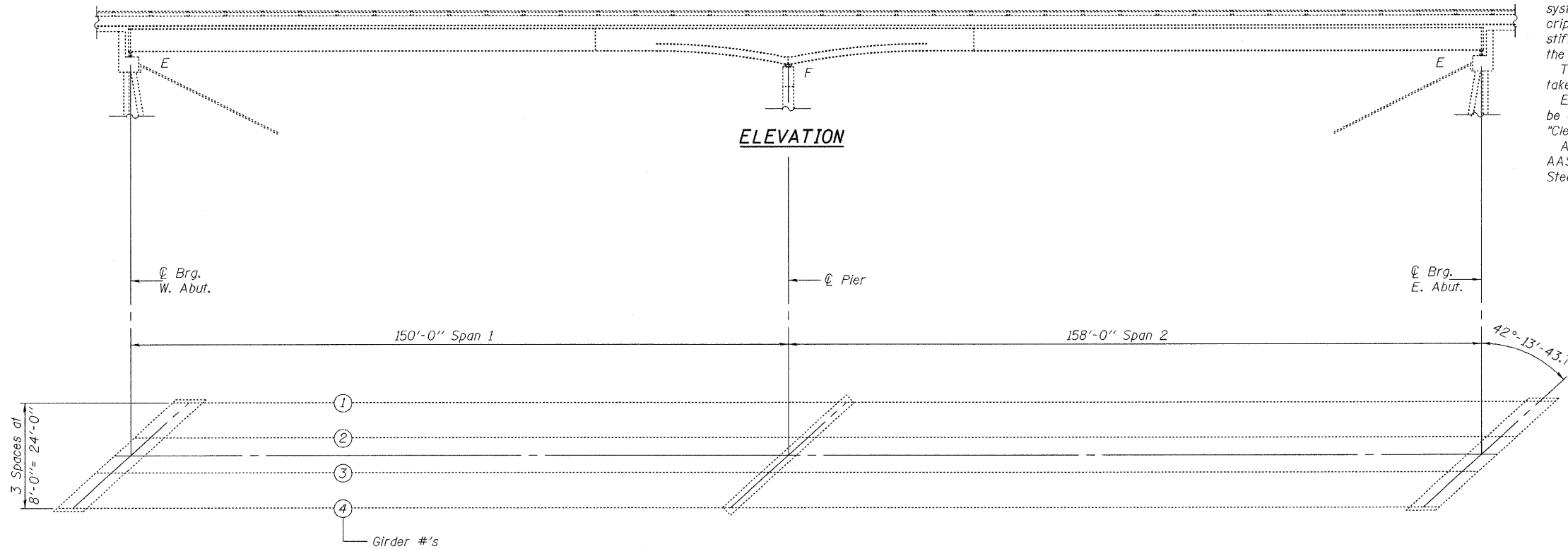

ELEVATION

PLAN

Remove and Replace Bearings at Abutments

BILL OF MATERIAL

ITEM	UNIT	TOTAL
Furnishing & Erecting Structural Steel	Pound	1900
Anchor Bolts, 1 1/2" φ	Each	16
Elastomeric Bearing Assembly, Type I	Each	8
Jack and Remove Existing Bearings	Each	8

**BEARING REPLACEMENT
PLAN & ELEVATION
CH. 18 OVER FAI RT. 72
SN 058-0097**

DESIGNED	Aug. B. Bapat
CHECKED	Sital Bhabha
DRAWN	Steffen
CHECKED	VHV

OCTOBER 30, 2009
EXAMINED *[Signature]*
ENGINEER OF STRUCTURAL SERVICES
PASSED *[Signature]*
ENGINEER OF BRIDGES AND STRUCTURES



EXPIRES 11-30-2010

SHEET NO. 16	F.A.I. RTE.	SECTION	COUNTY	TOTAL SHEETS	SHEET NO.
17 SHEETS	72	66(B,HVB,HB-1)BR	MACON	83	81
FED. ROAD DIST. NO.			ILLINOIS FED. AID PROJECT		
CONTRACT NO. 74343					

STATE OF ILLINOIS
DEPARTMENT OF TRANSPORTATION

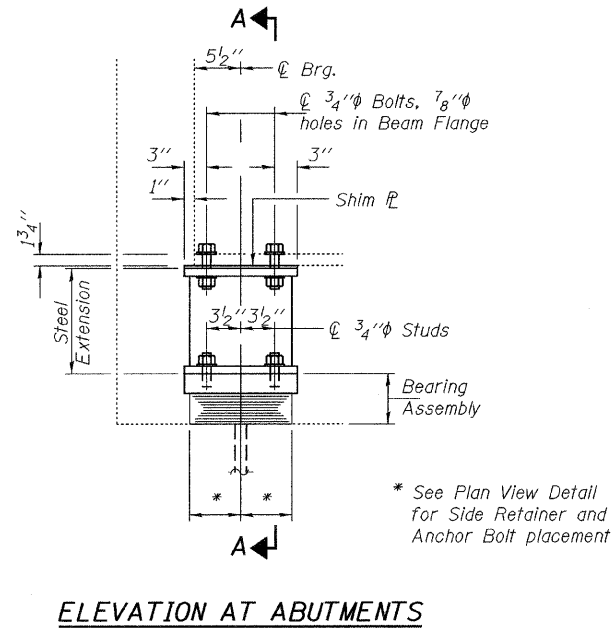

ELEVATION AT ABUTMENTS

TYPE I ELASTOMERIC EXP. BRG.

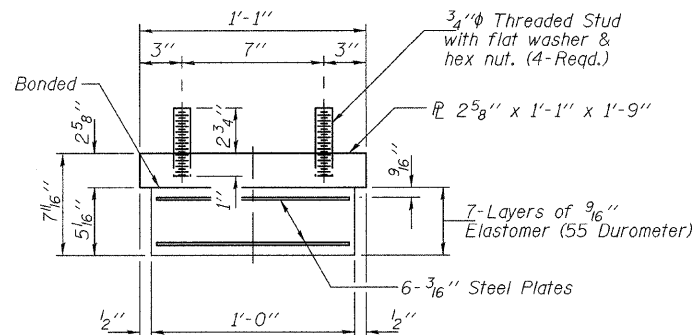

BEARING ASSEMBLY

Note:
Shim plates shall not be placed under Bearing Assembly.

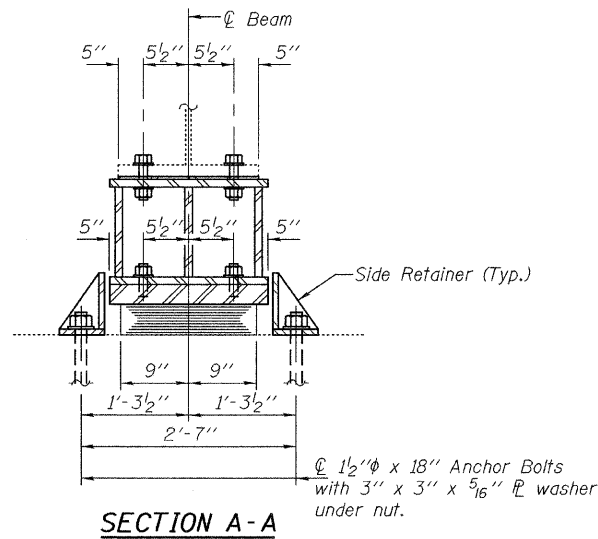

SECTION A-A

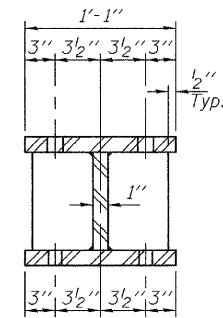

SECTION B-B

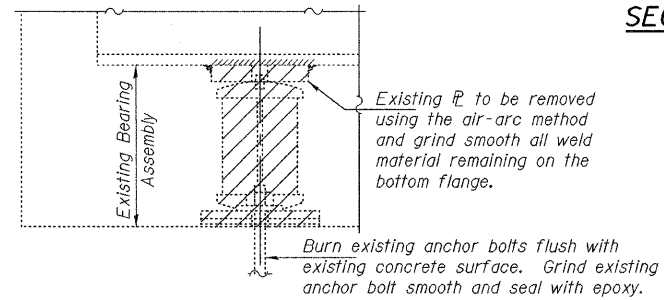

EXISTING BEARING REMOVAL DETAIL

Cost included with Jack and Remove Existing Bearings.

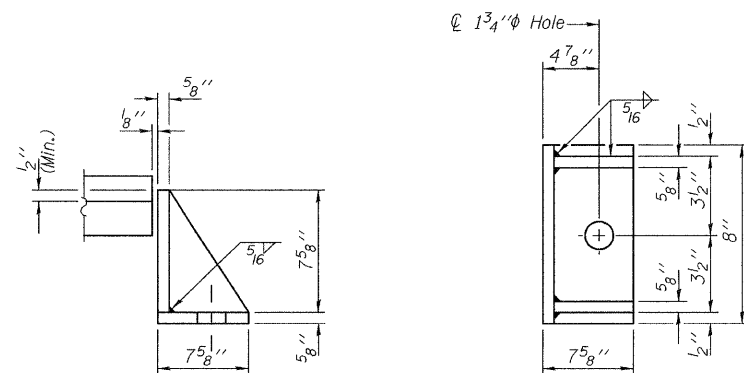

SIDE RETAINER

Equivalent rolled angle with stiffeners will be allowed in lieu of welded plates.

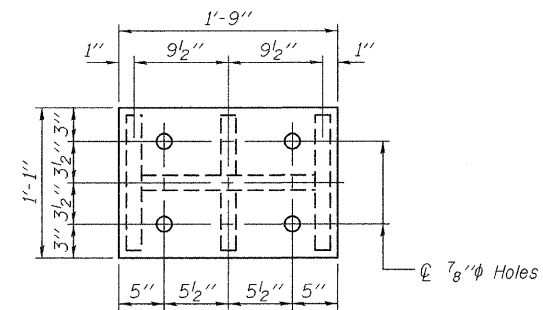

PLAN TOP AND BOTTOM PLATE

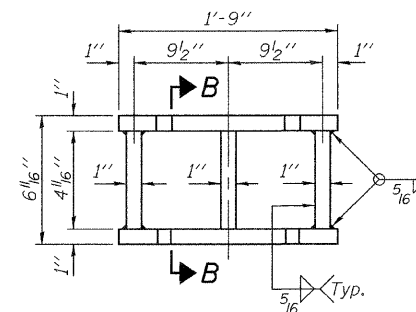

STEEL EXTENSION DETAIL

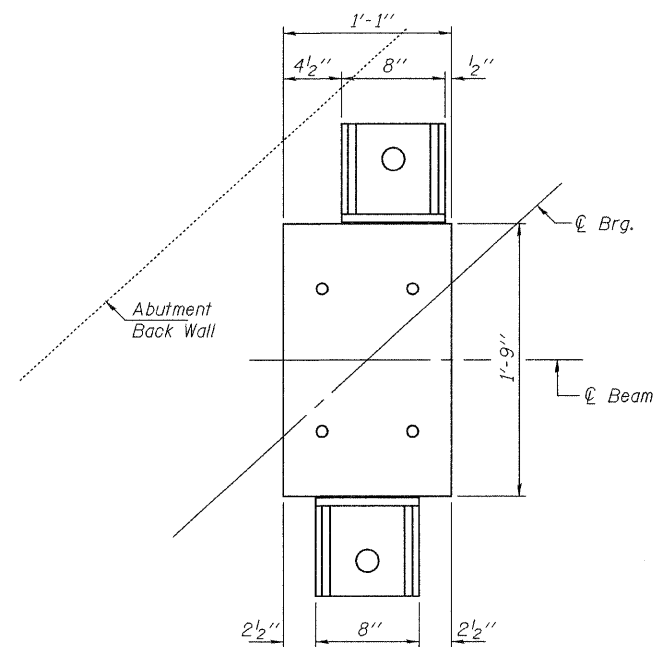

PLAN VIEW SHOWING PLACEMENT OF SIDE RETAINERS

Notes:
Diaphragm removal and installation may be required to facilitate drilling holes. Cost included with Furnishing and Erecting Structural Steel.
New steel extensions, shim plates and connection bolts are included with Furnishing and Erecting Structural Steel.
Prior to ordering any material, the Contractor shall verify in the field all bearing height and shim thickness dimensions. Min. jack capacity = 80 Tons for the West Abutment and 90 Tons for the East Abutment.
Anchor bolts shall be ASTM F1554 all-thread (or an Engineer-approved alternate material) of the grade(s) and diameter(s) specified. ASTM A307 Grade C anchor bolts may be used in lieu of ASTM F1554 Grade 36 (Fy=36ksi). The corresponding specified grade of AASHTO M314 anchor bolts may be used in lieu of ASTM F1554.
Side retainers shall be included in the cost of Elastomeric Bearing Assembly, Type I.
Drilled and set anchor bolts shall be installed according to Article 521.06 of the Standard Specifications.

SHIM PLATES

WEST ABUTMENT	
Girder 1	$1/4$ " x 13 " x 21 "
EAST ABUTMENT	
Girder 3	$3/8$ " x 13 " x 21 "

WEST ABUTMENT BEAM REACTIONS

R \varnothing	(K)	84.8
R \perp	(K)	37.2
Imp.	(K)	6.7
R (Total)	(K)	128.7

EAST ABUTMENT BEAM REACTIONS

R \varnothing	(K)	93.5
R \perp	(K)	38.4
Imp.	(K)	6.9
R (Total)	(K)	138.8

BILL OF MATERIAL

Item	Unit	Total
Elastomeric Bearing Assembly Type I	Each	8
Jack and Remove Existing Bearings	Each	8
Furnishing and Erecting Structural Steel	Pound	1900
Anchor Bolts, $1 1/2$ " ϕ	Each	16

ABUTMENT BEARING REPLACEMENT DETAILS
CH. 18 OVER FAI RT. 72
SN 058-0097

DESIGNED	AJB
CHECKED	SJB
DRAWN	Steffen
CHECKED	AJB SJB

OCTOBER 30, 2009
EXAMINED *Carl P. ...*
ENGINEER OF STRUCTURAL SERVICES
PASSED *Ralph E. Anderson*
ENGINEER OF BRIDGES AND STRUCTURES

SHEET NO. 17	F.A.I. RTE.	SECTION	COUNTY	TOTAL SHEETS	SHEET NO.
17 SHEETS	72	66(B,HVB,HB-1)BR	MACON	83	82
FED. ROAD DIST. NO.			ILLINOIS FED. AID PROJECT		
			CONTRACT NO. 74343		

DETAIL OF FLARED GUARDRAIL AT DUAL STRUCTURES

NOTE: NOT DRAWN TO SCALE

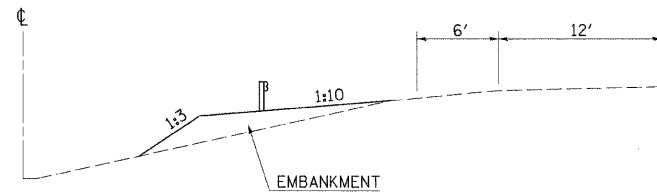
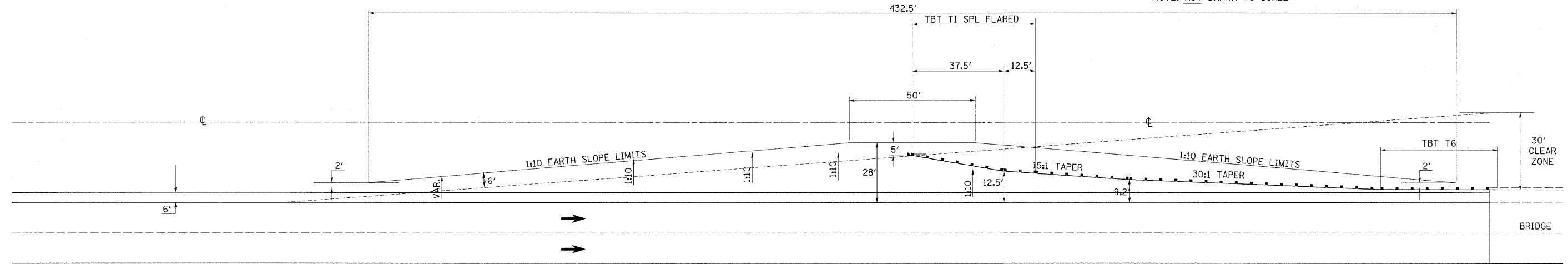

NOTE: SEE PLAN SHEET SCHEDULES FOR LOCATIONS AND STATIONING OF GUARDRAIL.

FILE NAME =	USER NAME = swartzrk	DESIGNED -	REVISED -
c:\pwork\PIWIDOT\SWARTZRK\dms37771\ah	details_74343.dgn	DRAWN -	REVISED -
	PLOT SCALE = 20.0000' / IN.	CHECKED -	REVISED -
	PLOT DATE = 9/28/2009	DATE -	REVISED -

STATE OF ILLINOIS
DEPARTMENT OF TRANSPORTATION

DETAILS

SCALE: NA SHEET NO. 1 OF 1 SHEETS STA. TO STA.

F.A.I. RTE.	SECTION	COUNTY	TOTAL SHEETS	SHEET NO.
72	66(B,HVB,HB-1)BR	MACON	83	83
CONTRACT NO. 74343				
FED. ROAD DIST. NO. ILLINOIS FED. AID PROJECT				