

STATE OF ILLINOIS  
DEPARTMENT OF TRANSPORTATION

ROUTE NO. F.A.U. 9181	SECTION 52BR	COUNTY ST. CLAIR	TOTAL SHEETS 41	SHEET NO. 37	SHEET NO. 21 25 SHEETS
FED. ROAD DIST. NO. 7		ILLINOIS		FED. AID PROJECT-	

Contract #76120

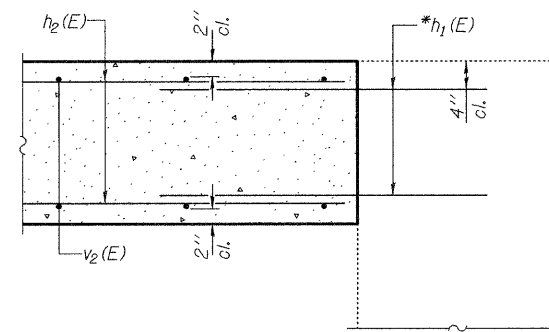
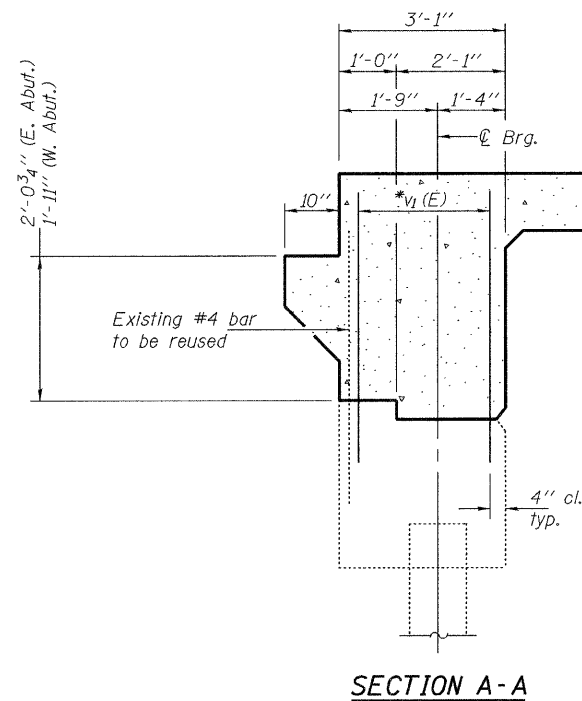
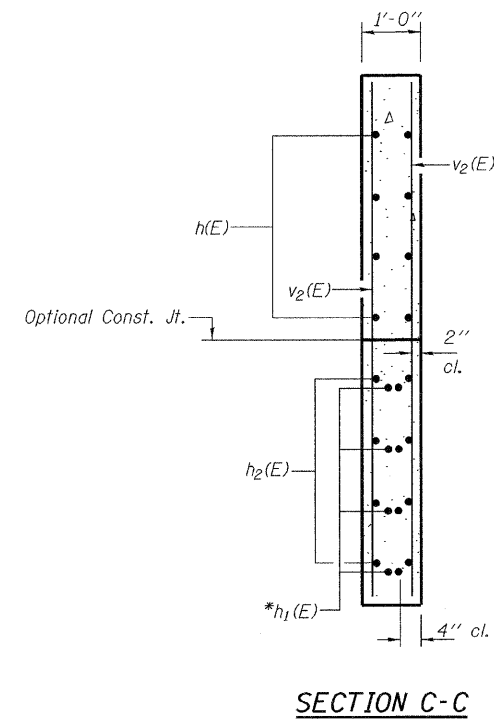
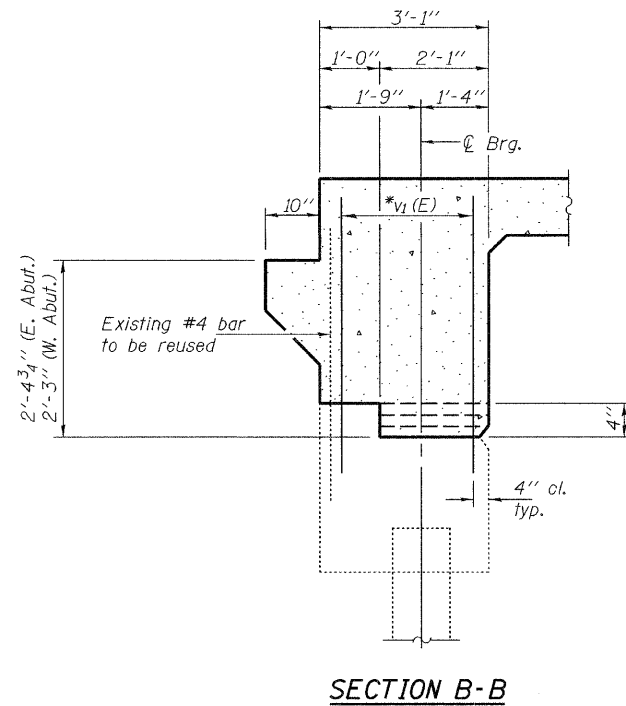

\*Epoxy grout  $h_1(E)$  and  $v_1(E)$  bars in 9" min. drilled holes according to Article 584 of the Standard Specifications.

**BILL OF MATERIAL FOR BOTH ABUTMENTS**

Bar	No.	Size	Length	Shape
$h(E)$	32	#6	12'-3"	—
$h_1(E)$	32	#7	4'-4"	—
$h_2(E)$	32	#7	8'-4"	—
$v_1(E)$	216	#5	4'-3"	—
$v_2(E)$	80	#5	6'-4"	—
Concrete Structures		Cu. Yd.	8.9	
Reinforcement Bars, Epoxy Coated		Pound	2900	
Structure Excavation		Cu. Yd.	171.0	

SECTION D-D

Notes:  
Existing reinforcement extending into removed areas shall be cleaned, straightened, and incorporated into the new construction. Cost included with Concrete Removal.  
Place  $v_1(E)$  bars in between existing #4 vertical bars at the back of abutment.

DESIGNED	WAB/SMR
CHECKED	DFZ/FT
DRAWN	BML PAUL W. SWEET
CHECKED	DFZ/SMR/DPN/FT

EXAMINED	November 23, 2009	Thomas J. Demagalaki
PASSED		Ralph E. Anderson

**ABUTMENT DETAILS**  
F.A.U. RTE. 9181 - SECTION 52BR  
ST. CLAIR COUNTY  
STATION 39+89.80  
STRUCTURE NO. 082-0136