

STATE OF ILLINOIS
DEPARTMENT OF TRANSPORTATION

BEAM REACTIONS

RP	(K)	54.2
R _L	(K)	51.0
Imp.	(K)	16.2
R (Total)	(K)	121.4

Notes:
Cross-frame removal and reinstallation may be required to facilitate drilling holes. Cost included with Furnishing and Erecting Structural Steel.

New steel extensions, shim plates and connection bolts are included with Furnishing and Erecting Structural Steel. Prior to ordering any material, the Contractor shall verify in the field all bearing height and shim thickness dimensions. Min. Jack capacity = 70 Tons.

Anchor bolts shall be ASTM F1554 all-thread (or an Engineer-approved alternate material) of the grade(s) and diameter(s) specified. ASTM A307 Grade C anchor bolts may be used in lieu of ASTM F1554 Grade 36 (F_y=36ksi). The corresponding specified grade of AASHTO M314 anchor bolts may be used in lieu of ASTM F1554.

Anchor bolts at fixed bearings may be either cast in place or installed in holes drilled after the supported member is in place.

Anchor bolts for Type II bearings shall be placed in holes drilled through the bottom bearing plate after members are in place. Side retainers shall be placed after bolts are installed.

Drilled and set anchor bolts shall be installed according to Article 521.06 of the Standard Specifications.

Side retainers shall be included in the cost of Elastomeric Bearing Assembly, Type II.

The 1/8" PTFE sheet shall be bonded directly to the top steel plate with a two-component, medium viscosity epoxy resin, conforming to the requirements of the Federal Specification MMM-A-134, Type I. The bond agent shall be applied on the full area of the contact surfaces.

Bonding of 1/8" PTFE sheet during vulcanizing process will be permitted provided the process and method of adjusting assembly height is approved by the Engineer.

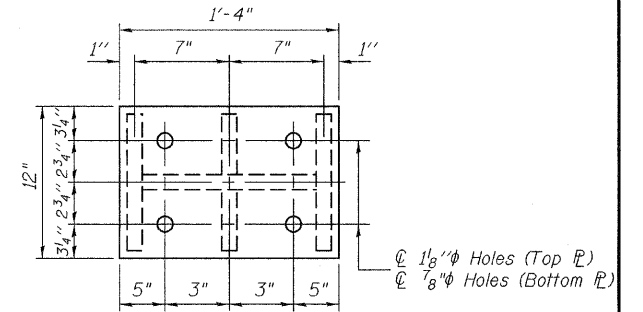

PLAN TOP AND BOTTOM PLATE

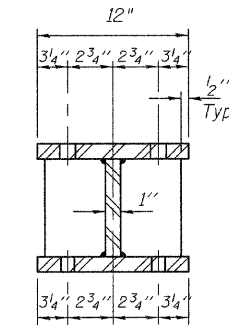

SECTION B-B

STEEL EXTENSION DETAIL

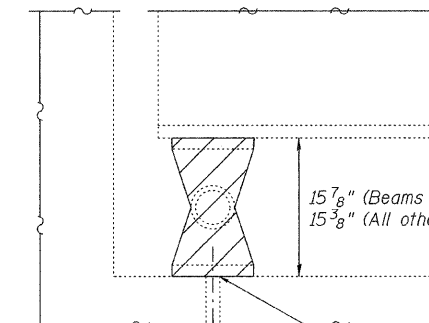

JACK AND REMOVE EXISTING BEARING

Burn existing anchor bolts flush with existing concrete surface. Grind existing anchor bolts smooth and seal with epoxy. Cost is included in "Jack and Remove Existing Bearings".

BILL OF MATERIAL

Item	Unit	Total
Elastomeric Bearing Assembly, Type II	Each	14
Jack and Remove Existing Bearings	Each	14
Furnishing and Erecting Structural Steel	Pound	2,540
Anchor Bolts 1 1/4" x 15"	Each	28

BEARING DETAILS - N. ABUTMENT
SN 082-0247 & 0248

SHEET NO. 18 20 SHEETS	F.A.I. RTE.	SECTION	COUNTY	TOTAL SHEETS	SHEET NO.
	255	82-1HVB-I-1	ST. CLAIR	45	43
FED. ROAD DIST. NO.			ILLINOIS FED. AID PROJECT		
CONTRACT NO. 76926					

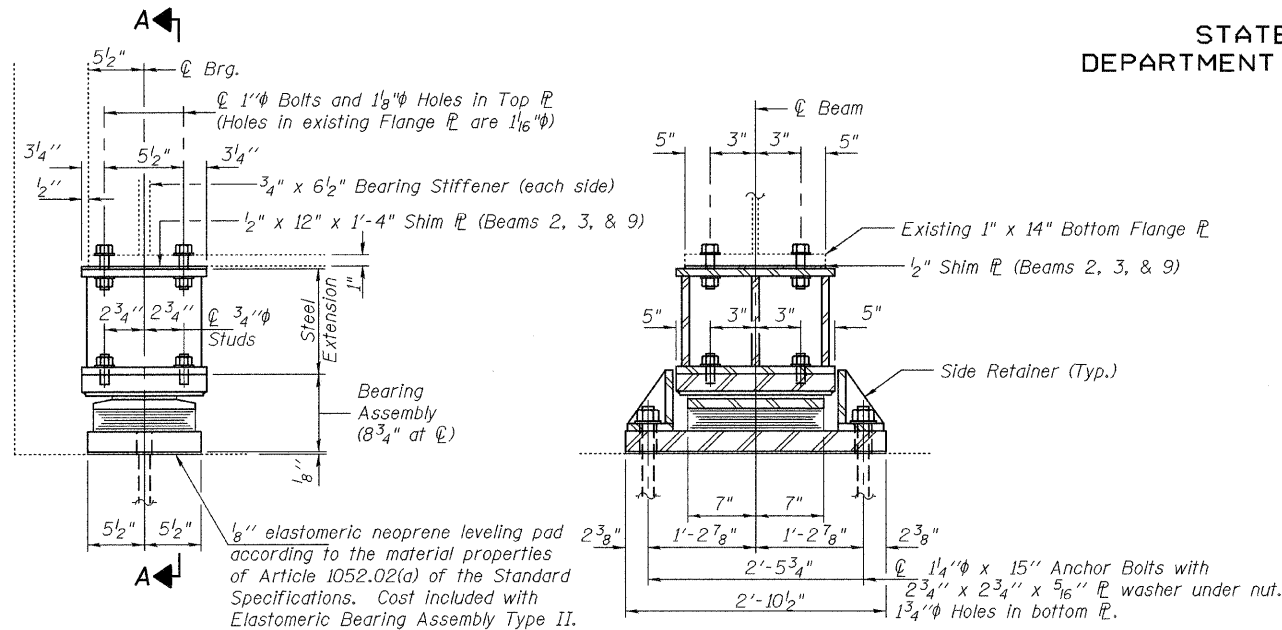

ELEVATION AT ABUTMENT

SECTION A-A

TYPE II TFE ELASTOMERIC EXP. BRG.

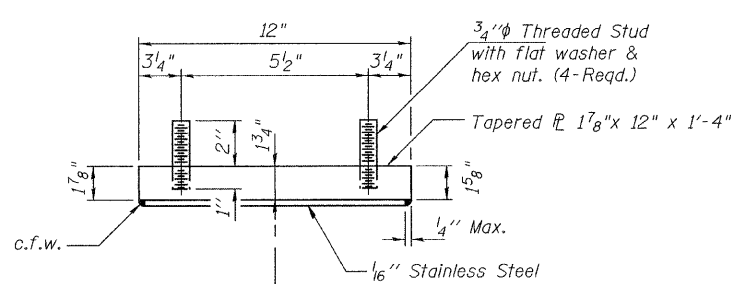

TOP BEARING ASSEMBLY

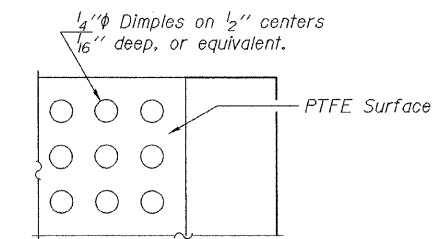

PLAN-PTFE SURFACE

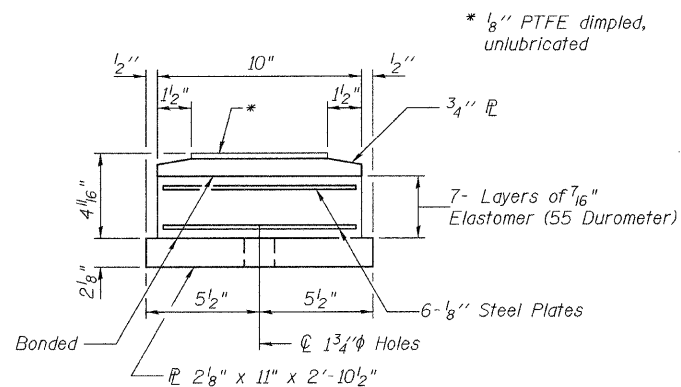

BOTTOM BEARING ASSEMBLY

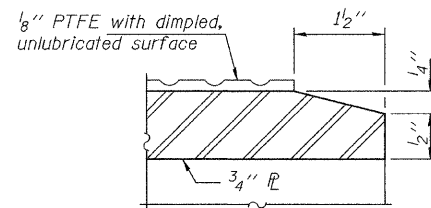

SECTION THRU PTFE

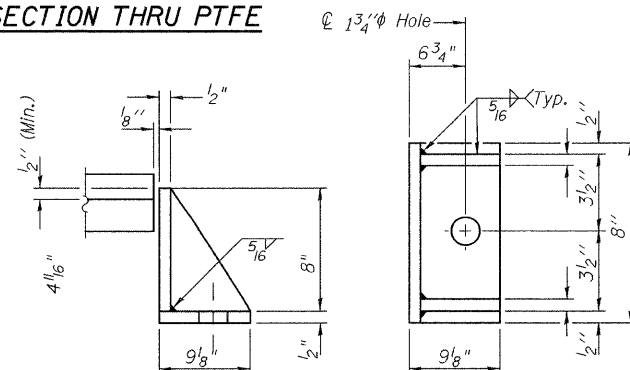

SIDE RETAINER

Equivalent rolled angle with stiffeners will be allowed in lieu of welded plates.

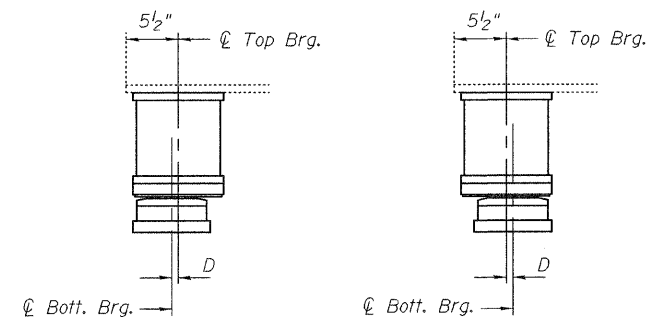

SETTING ANCHOR BOLTS AT EXP. BRG.

D = 1/8" per each 100' of expansion for every 15° temp. change from the normal temp. of 50°F.

DESIGNED	J. Uehle
CHECKED	A. Hallway
DRAWN	J. Uehle
CHECKED	A. Hallway

NOVEMBER 5, 2009	
EXAMINED	<i>A. Carl Perry</i>
PASSED	<i>Ralph E. Anderson</i>
	ENGINEER OF BRIDGES AND STRUCTURES

TYII/REPS 12-03-2008