

F.A.S. ROUTE NO.	SECTION	ILLINOIS PROJECT	CONTRACT NO.	COUNTY	TOTAL SHEETS	SHEET NUMBER
268	06-00173-00-SW	TE-00D3(58)	87359	LASALLE	15	11

F.A.S. 268 - MAIN STREET
 SECTION 06-00173-00-SW
 CITY OF MARSEILLES, LASALLE COUNTY

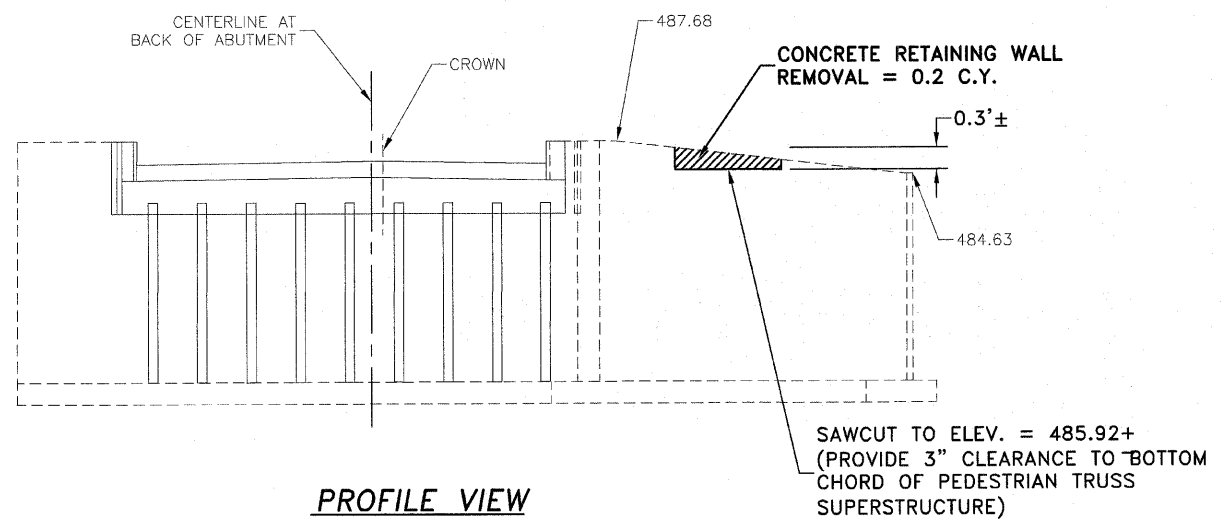

PROFILE VIEW

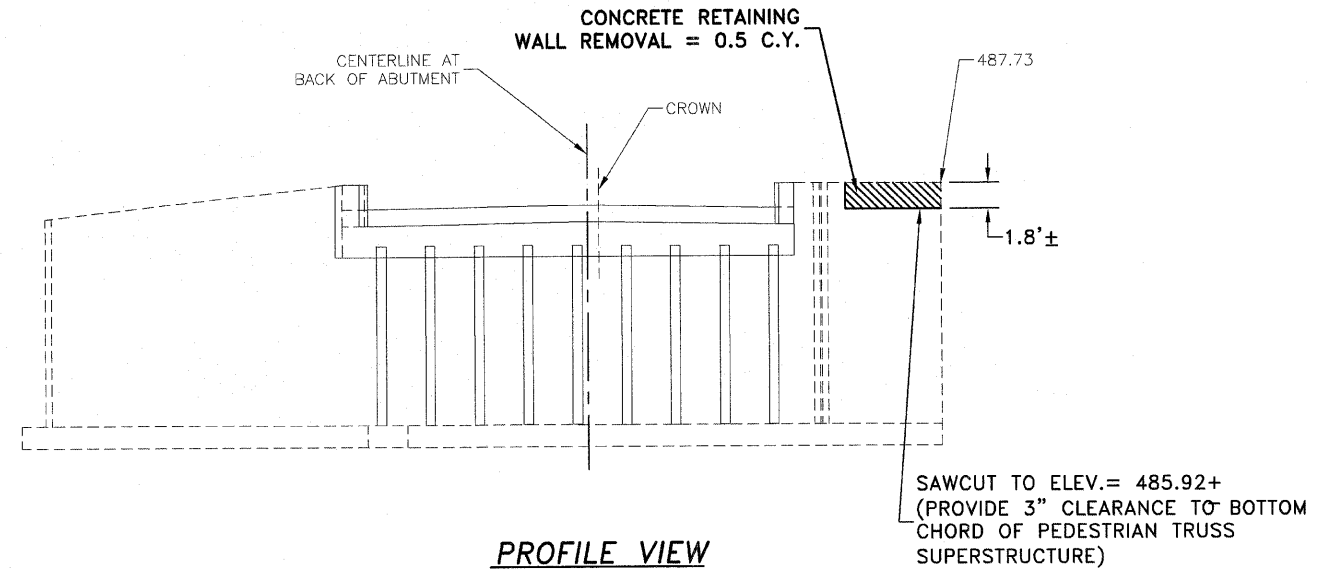

PROFILE VIEW

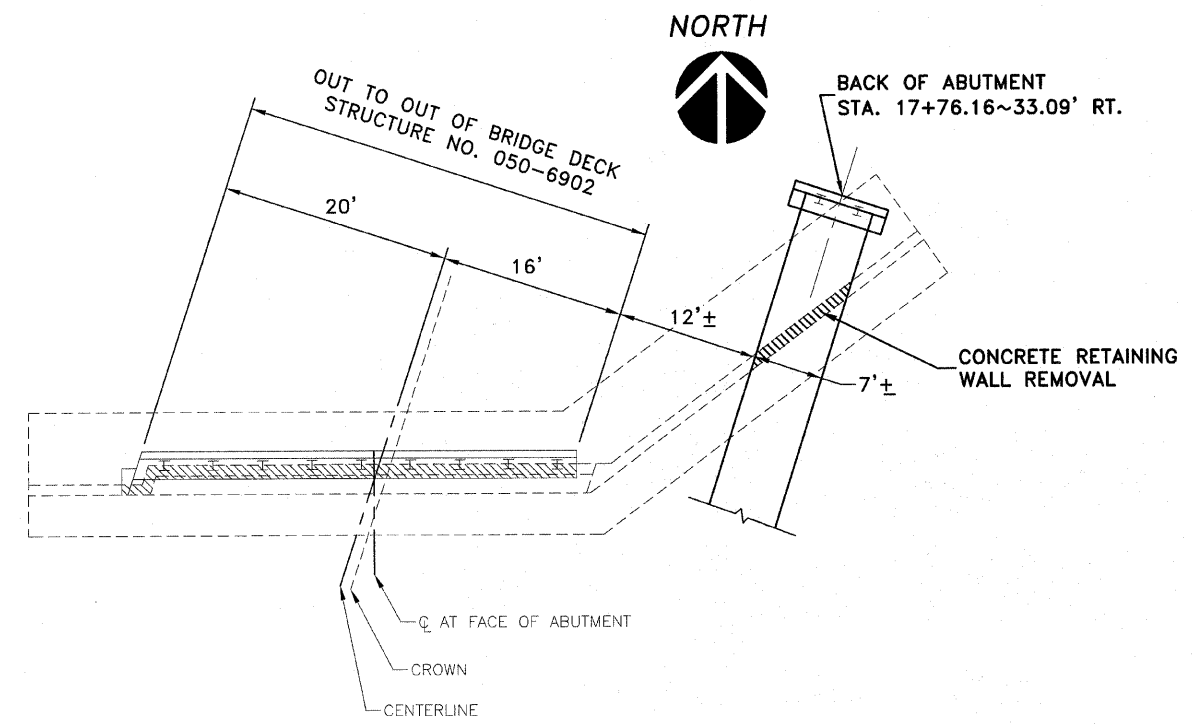

PLAN VIEW

NORTH ABUTMENT - SOUTH MILL RACE
NOT TO SCALE

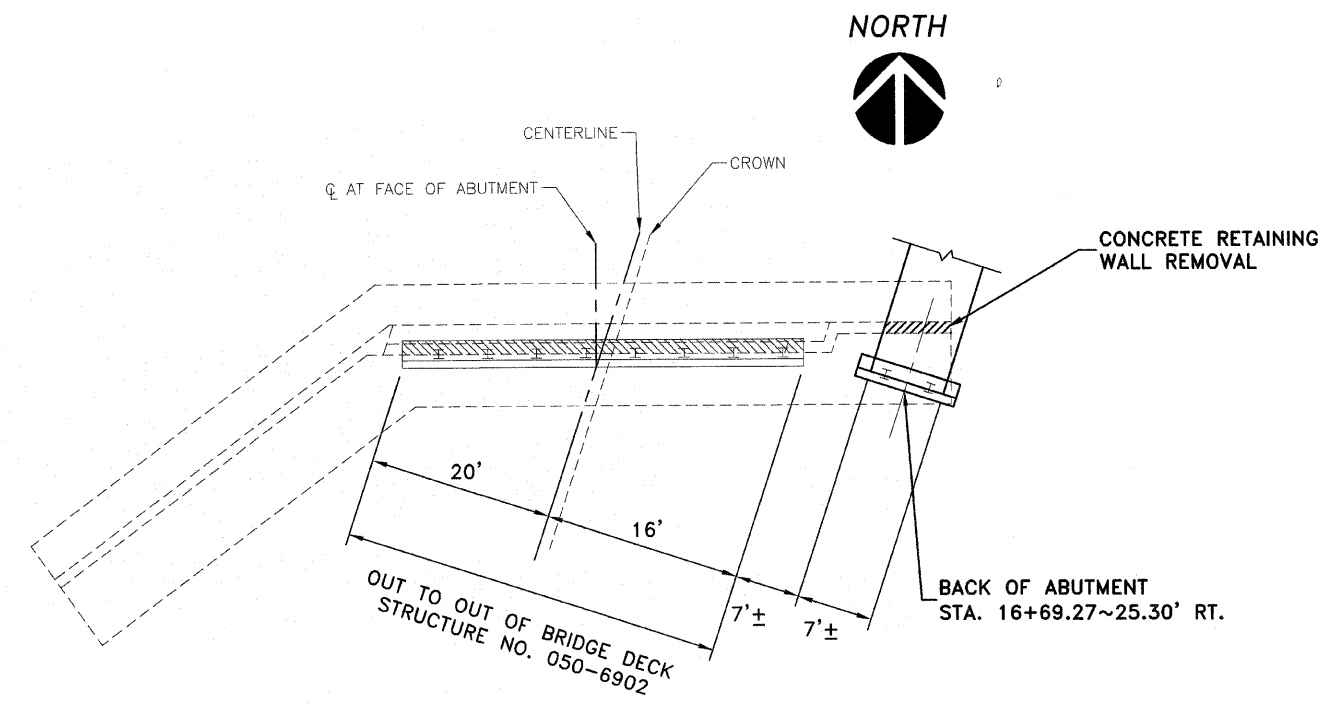

PLAN VIEW

SOUTH ABUTMENT - SOUTH MILL RACE
NOT TO SCALE

1304 GEMINI CIRCLE
 OTTAWA, IL 62356-7692
 TEL: 815-464-3925
 FAX: 815-464-3955

E TSCHIED
DUTTlinger
& ASSOCIATES INC.
 Professional Engineers & Land Surveyors

PROFESSIONAL DESIGN FIRM # 184-000711
DATE PLOTTED: OCTOBER 21, 2009
DRAWN BY: R.M.S.
CHECKED BY:
PROJECT NUMBER: 2057.92
DRAWING FILE: 205792_EXIST_WALL
SHEET NO.
11 OF 15