

STATE OF ILLINOIS
DEPARTMENT OF TRANSPORTATION
DIVISION OF HIGHWAYS

F.A.P. RTE.	SECTION	COUNTY	TOTAL SHEETS	SHEET NO.
870 & 347	13-00078-00-TL	DuPAGE	21	1
		ILLINOIS	CONTRACT NO. 61A67	

FOR INDEX OF SHEETS, SEE SHEET NO. 2

TRAFFIC DATA:

ADT:
IL RTE 53 = 15,800 (2013)
IL RTE 38 = 44,500 (2013)
LAMBERT RD = 7,500 (2012)

POSTED SPEED LIMIT:

IL RTE 53 = 40 MPH
IL RTE 38 = 35 MPH
NICOLL WAY = 30 MPH

DESIGN DESIGNATION:

IL RTE 53 = OTHER PRINCIPAL ARTERIAL
IL RTE 38 = OTHER PRINCIPAL ARTERIAL
NICOLL WAY = OTHER PRINCIPAL ARTERIAL
PERSHING AVE = OTHER PRINCIPAL ARTERIAL
LAMBERT RD = MAJOR COLLECTOR

PROJECT LOCATED IN
VILLAGE OF GLEN ELLYN

**PLANS FOR PROPOSED
FEDERAL AID HIGHWAY**

FAP 870 (IL RTE 53) AT PERSHING AVENUE

FAP 347 (IL RTE 38) AT NICOLL WAY

FAP 347 (IL RTE 38) AT LAMBERT ROAD

TRAFFIC SIGNAL MODERNIZATION

SECTION: 13-00078-00-TL

PROJECT: CMM-4003 (295)

VILLAGE OF GLEN ELLYN

DuPAGE COUNTY

C-91-251-14



LOCATION OF SECTION INDICATED THUS: - [black rectangle] -

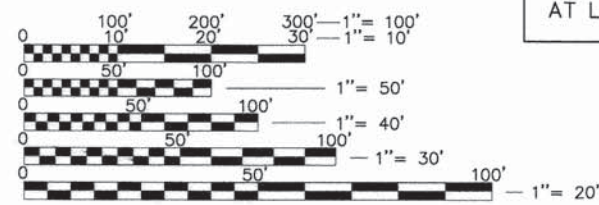

FULL SIZE PLANS HAVE BEEN PREPARED USING STANDARD ENGINEERING SCALES. REDUCED SIZED PLANS WILL NOT CONFORM TO STANDARD SCALES. IN MAKING MEASUREMENTS ON REDUCED PLANS, THE ABOVE SCALES MAY BE USED.

ILL RTE 38 (ROOSEVELT ROAD)
AT LAMBERT ROAD

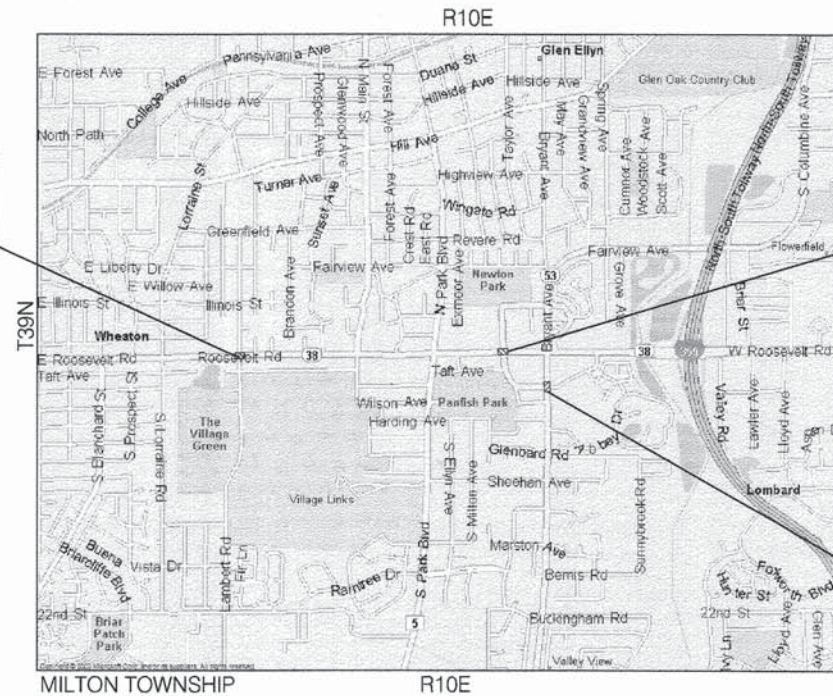

ILL RTE 38 (ROOSEVELT ROAD)
AT NICOLL WAY

ILL RTE 53 (BRYANT AVENUE)
AT PERSHING AVENUE

LOCATION MAP
SCALE: NTS

GROSS & NET LENGTH OF PROJECT = 900 FT. = (0.170 MILES)

J.U.L.I.E.
JOINT UTILITY LOCATION INFORMATION FOR EXCAVATION
1-800-892-0123
OR 811

CONTRACT NO. 61A67

STATE OF ILLINOIS
DEPARTMENT OF TRANSPORTATION
DIVISION OF HIGHWAYS

APPROVED: *October 7th* 2015
Julius Hansen
Village of Glen Ellyn, Director of Public Works

PASSED: *October 23* 2015
C. Holt
District 1 Engineer of Local Roads & Streets

Releasing for Bid
Based on Limited Review *October 23* 2015
John F. ...
Deputy Director of Highways, Region 1 Engineer

PRINTED BY AUTHORITY OF THE STATE OF ILLINOIS
JAMES J. BENES & ASSOCIATES, INC.

JAMES J. BENES & ASSOCIATES
CONSULTING ENGINEERS
950 WARRENVILLE ROAD, SUITE 101
LISLE, IL 60532
(630) 719-7570

SIGNATURE: *[Signature]*
DATE: *10-23-15*
IL LICENSE NO. 062-039438
EXP. DATE: NOVEMBER 30, 2015
FIELD: JAMES J. BENES AND ASSOCIATES, INC.
CIVIL ENGINEERING

FEDERAL AID PROGRAM ENGINEER: FAWAD AQUEEL (847) 705-4021, SCHAUMBURG, IL

INDEX OF SHEETS

SHEET NO.	TITLE
1	TITLE SHEET
2	GENERAL NOTES, INDEX OF SHEETS AND LIST OF STATE STANDARDS
3	SUMMARY OF QUANTITIES
4	TRAFFIC SIGNAL MODERNIZATION PLAN IL RTE 53 AT PERSHING AVENUE
5	CABLE PLAN IL RTE 53 AT PERSHING AVENUE
6	SIDEWALK CORNER DETAILS IL RTE 53 AT PERSHING AVENUE
7	TRAFFIC SIGNAL MODERNIZATION PLAN IL RTE 38 AT NICOLL WAY
8	CABLE PLAN IL RTE 38 AT NICOLL WAY
9	SIDEWALK CORNER PLAN IL RTE 38 AT NICOLL WAY
10	TRAFFIC SIGNAL MODERNIZATION PLAN IL RTE 38 AT LAMBERT ROAD
11	CABLE PLAN IL RTE 38 AT LAMBERT ROAD
12-21	DISTRICT ONE DETAILS

BENCH MARKS

REFERENCE BENCHMARKS

RM1- BONNET BOLT BETWEEN "MUE" & "LLER" ON HYDRANT BETWEEN 129 AND 133 MILTON AVENUE, ON EAST SIDE OF STREET, SOUTH OF HARDING AVENUE. ELEVATION=755.93

RM2- BONNET BOLT BETWEEN "MUE" & "LLER" ON HYDRANT AT THE SOUTHWEST CORNER OF MILTON AVENUE AND HARDING AVENUE. ELEVATION=753.73

(REFERENCE BENCHMARKS TAKEN FROM SITE IMPROVEMENT PLANS FOR BRENTWOOD PLACE)

PROJECT BENCHMARKS

TBM1- ARROW BOLT ON HYDRANT AT SOUTHWEST CORNER OF NICOLL WAY AND PERSHING AVENUE. ELEVATION=759.12

TBM2- BONNET BOLT ON HYDRANT AT SOUTHWEST CORNER OF NICOLL WAY AND TAFT AVENUE. ELEVATION= 762.07

LAMBERT ROAD BASE SURVEY BY THOMAS ENGINEERING GROUP
RTE 53/ PERSHING BASE SURVEY BY CEMCON, LTD.

HOT - MIX ASPHALT MIXTURE REQUIREMENTS

MIXTURE TYPE	AIR VOIDS @Ndes
CLASS D PATCHES (HMA BINDER IL- 19MM)	4% @ 70 Gyr.

- THE UNIT WEIGHT USED TO CALCULATE ALL HMA SURFACE MIXTURE QUANTITIES IS 112 LBS/SQ YD/IN.
- THE "AC TYPE" FOR POLYMERIZED MIXES SHALL BE "SBS/SBR PG 76-22" AND FOR NON POLYMERIZED HMA THE "AC TYPE" SHALL BE "PG 64-22" UNLESS MODIFIED BY DISTRICT ONE SPECIAL PROVISIONS.
- FOR USE OF RECYCLED MATERIAL SEE SPECIAL PROVISIONS.

COMMITMENTS: NONE

GENERAL NOTES

- THE CONTRACTOR SHALL GIVE THE MUNICIPALITY THREE (3) WORKING DAYS NOTICE PRIOR TO THE COMMENCEMENT OF WORK. (VILLAGE OF GLEN ELLYN: (630) 469-6756)
- ALL ELEVATIONS ARE ON NAVD 88 DATUM.
- DO NOT SCALE PLANS FOR CONSTRUCTION DIMENSIONS.
- THE ENGINEER SHALL NOT ASSUME ANY OF THE RESPONSIBILITIES OF THE CONTRACTOR'S SUPERINTENDENT OR OF SUBCONTRACTORS. ADDITIONALLY, THE ENGINEER SHALL NOT ADVISE ON, OR ISSUE DIRECTIONS CONCERNING, ASPECTS OF CONSTRUCTION MEANS, METHODS, TECHNIQUES, SEQUENCES OR PROCEDURES, OR SAFETY PRECAUTIONS AND/OR PROGRAMS IN CONNECTION WITH THE WORK.
- THE CONTRACTOR SHALL KEEP THE CONSTRUCTION AREA FREE OF DEBRIS AND/OR OBJECTIONABLE MATERIALS DURING CONSTRUCTION. THE CONTRACTOR SHALL INSPECT THE SITE DAILY FOR DEBRIS ON THE ROADWAY SURFACE. THE RIGHT-OF-WAY SHALL BE RESTORED TO PRE-CONSTRUCTION CONDITION IN ACCORDANCE WITH ARTICLE 107.20.
- THE CONTRACTOR SHALL MAINTAIN ALL EXISTING DRAINAGE FACILITIES DURING CONSTRUCTION AND SHALL REPAIR ANY DRAINAGE FACILITIES DAMAGED DURING CONSTRUCTION. THIS WORK SHALL BE INCLUDED IN THE COST OF THE DRAINAGE ITEMS BEING CONSTRUCTED AND WILL NOT BE PAID FOR SEPARATELY.
- THE RELOCATION OF SIGNS SHALL BE INCLUDED IN THE COST OF TRAFFIC CONTROL AND PROTECTION AND WILL NOT BE PAID FOR SEPARATELY IN ACCORDANCE WITH ARTICLE 107.25.
- BEFORE STARTING ANY EXCAVATION, THE CONTRACTOR SHALL CALL "J.U.L.I.E." AT (800) 892-0123 FOR FIELD LOCATIONS OF BURIED ELECTRIC, TELEPHONE, GAS, SEWERS AND WATER UTILITIES. (48 HOUR NOTIFICATION IS REQUIRED.)
- SAW CUTTING OF PAVEMENT, SHOULDERS, CURB AND GUTTER, ETC. SHALL BE TO FULL DEPTH AND SHALL RESULT IN CLEAN, STRAIGHT EDGE ON THE PORTION REMAINING. ALL SAW CUTTING SHALL BE CONSIDERED INCLUDED IN THE COST OF THE ITEM REMOVED.
- THE RESIDENT ENGINEER SHALL CONTACT MR. DON CHIARUGI, AREA TRAFFIC FIELD ENGINEER AT (847) 741-9857 A MINIMUM OF TWO WEEKS PRIOR TO THE PLACEMENT OF PERMANENT PAVEMENT MARKINGS.
- ALL CONSTRUCTION SHALL BE DONE IN ACCORDANCE WITH THE "STANDARD SPECIFICATIONS FOR ROAD AND BRIDGE CONSTRUCTION", ADOPTED JANUARY 1, 2012; THE "SUPPLEMENTAL SPECIFICATIONS AND RECURRING SPECIAL PROVISIONS", ADOPTED JANUARY 1, 2015; THE LATEST EDITION OF THE "ILLINOIS MANUAL ON UNIFORM TRAFFIC CONTROL DEVICES FOR STREETS AND HIGHWAYS" (MUTCD), "STANDARD SPECIFICATIONS FOR WATER AND SEWER MAIN CONSTRUCTION IN ILLINOIS" JULY 2009 SIXTH EDITION, THE "DETAILS" IN THE PLANS AND THE "SPECIAL PROVISIONS" INCLUDED IN THE CONTRACT DOCUMENTS.
- THE CONTRACTOR SHALL BE RESPONSIBLE FOR HIRING AN ENVIRONMENTAL FIRM WITH AT LEAST FIVE (5) DOCUMENTED LEAKING UNDERGROUND STORAGE TANKS (LUST) CLEANUPS OR THAT IS PRE-QUALIFIED IN HAZARDOUS WASTE BY THE DEPARTMENT TO REMEDIATE THE SOIL CONTAMINATION AND MONITOR FOR WORKER PROTECTION.
- IN ACCORDANCE WITH ARTICLE 107.25, THE RELOCATION OF ALL SIGNS IS INCLUDED IN THE COST OF THE CONTRACT AND NO ADDITIONAL COMPENSATION WILL BE ALLOWED.

TRAFFIC SIGNAL GENERAL NOTES

BEFORE STARTING ANY EXCAVATION, THE CONTRACTOR SHALL CALL "J.U.L.I.E." AT (800) 892-0123 OR 811 FOR FIELD LOCATIONS OF BURIED ELECTRIC, TELEPHONE AND GAS UTILITIES. 48 HOUR NOTIFICATION IS REQUIRED.

THE CONTRACTOR SHALL CONTACT THE TRAFFIC CONTROL SUPERVISOR (847) 705-4470 72 HOURS IN ADVANCE OF BEGINNING WORK.

IT SHALL BE THE CONTRACTOR'S RESPONSIBILITY TO VERIFY ALL DIMENSIONS AND CONDITIONS EXISTING IN THE FIELD PRIOR TO ORDERING MATERIALS AND BEGINNING CONSTRUCTION. THIS SHALL INCLUDE LOCATING THE MAST ARM FOUNDATIONS AND VERIFYING THE MAST ARM LENGTHS.

THE EXACT LOCATION OF ALL UTILITIES SHALL BE FIELD VERIFIED BY THE CONTRACTOR BEFORE ORDERING ANY MATERIALS AND STARTING ANY WORK. FOR LOCATIONS OF UTILITIES, LOCALLY OWNED EQUIPMENT, LEASED ENFORCEMENT CAMERA SYSTEM FACILITIES AND IDOT UNDERGROUND FACILITIES, CONTACT THE LOCAL COUNTIES, MUNICIPALITIES AND IDOT FOR LOCATES. THE CONTRACTOR SHALL CALL "J.U.L.I.E." AT (800) 892-0123 OR 811. IN THE CITY OF CHICAGO CONTACT DIGGER AT (312) 744-7000 FOR FIELD LOCATIONS OF BURIED UTILITIES (48 HOURS NOTIFICATION REQUIRED).

IF THIS CONTRACT REQUIRES THE SERVICES OF AN ELECTRICAL CONTRACTOR, THE CONTRACTOR SHALL BE RESPONSIBLE AT HIS/HER OWN EXPENSE FOR LOCATING EXISTING IDOT ELECTRICAL FACILITIES PRIOR TO PERFORMING ANY WORK. IF THIS CONTRACT DOES NOT REQUIRE THE SERVICES OF AN ELECTRICAL CONTRACTOR, THE CONTRACTOR MAY REQUEST ONE FREE LOCATE FOR EXISTING IDOT ELECTRICAL FACILITIES FROM THE DISTRICT ONE ELECTRICAL MAINTENANCE CONTRACTOR PRIOR TO THE START OF WORK. ADDITIONAL REQUESTS MAY BE AT THE EXPENSE OF THE CONTRACTOR. THE LOCATION OF UNDERGROUND TRAFFIC FACILITIES DOES NOT RELIEVE THE CONTRACTOR OF THEIR RESPONSIBILITY TO REPAIR ANY FACILITIES DAMAGED DURING CONSTRUCTION AT THEIR EXPENSE.

THE CONTRACTOR SHALL CHECK THE PROPOSED TRAFFIC SIGNAL EQUIPMENT LOCATIONS FOR OVERHEAD UTILITY CONFLICTS. THE CONTRACTOR SHALL COORDINATE ANY CONFLICTS WITH THE UTILITY COMPANIES AND THE RESIDENT ENGINEER BEFORE ORDERING MATERIALS.

THE CONTRACTOR SHALL COORDINATE CONSTRUCTION ACTIVITIES WITH UTILITY COMPANIES, LOCAL GOVERNMENT AND IDOT.

RESTORATION OF THE TRAFFIC SIGNAL WORK AREA SHALL BE INCLUDED IN THE RELATED PAY ITEM SUCH AS FOUNDATION, CONDUIT, HANDHOLE, ETC., AND NO EXTRA COMPENSATION SHALL BE ALLOWED. ALL ROADWAY SURFACES SUCH AS SHOULDERS, MEDIAN, SIDEWALKS, PAVEMENT, ETC. SHALL BE REPLACED IN KIND. ALL DAMAGE TO MOWED LAWNS SHALL BE REPLACED WITH AN APPROVED SOD, AND ALL DAMAGE TO UNMOWED FIELDS SHALL BE SEEDED IN ACCORDANCE WITH STANDARD SPECIFICATIONS 252 AND 250 RESPECTIVELY.

HIGHWAY STANDARDS

STD. NO.	DESCRIPTION
000001-06	STANDARD SYMBOLS, ABBREVIATIONS AND PATTERNS
424001-08	PERPENDICULAR CURB RAMPS FOR SIDEWALKS
424011-02	CORNER PARALLEL CURB
424021-03	DEPRESSED CORNER FOR SIDEWALK
606001-06	CONCRETE CURB TYPE B AND COMBINATION CONCRETE CURB AND GUTTER
701701-09	URBAN LANE CLOSURE MULTI-LANE INTERSECTION
701801-05	SIDEWALK CORNER OR CROSSWALK CLOSURE
701901-04	TRAFFIC CONTROL DEVICES
805001-01	ELECTRICAL SERVICE INSTALLATION DETAILS
814001-03	HANDHOLES
814006-02	DOUBLE HANDHOLES
857001-01	STANDARD PHASE DESIGNATION DIAGRAMS AND PHASE SEQUENCES
873001-02	TRAFFIC SIGNAL GROUNDING & BONDING
876001-03	PEDESTRIAN PUSH BUTTON POST
877001-05	STEEL MAST ARM ASSEMBLY AND POLE 16' THROUGH 55'
878001-10	CONCRETE FOUNDATION DETAILS
880006-01	TRAFFIC SIGNAL MOUNTING DETAILS
886001-01	DETECTOR LOOP INSTALLATIONS
886006-01	TYPICAL LAYOUTS FOR DETECTION LOOPS

LIST OF DISTRICT ONE DETAILS

TC-10	TRAFFIC CONTROL AND PROTECTION PLAN FOR SIDE ROADS, INTERSECTIONS, AND DRIVEWAYS
TC-13	DISTRICT ONE TYPICAL PAVEMENT MARKINGS
TC-22	ARTERIAL ROAD INFORMATION SIGN
TS-05	STANDARD TRAFFIC SIGNAL DESIGN DETAILS

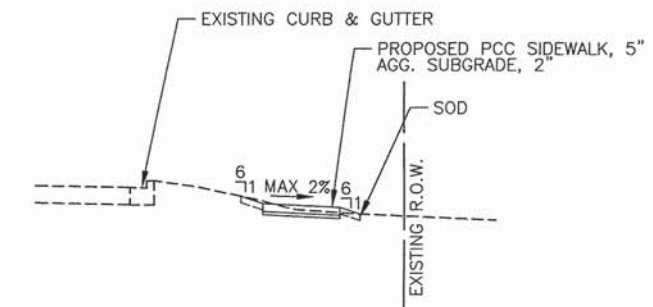

EXISTING & PROPOSED TYPICAL CROSS SECTION (SOUTHEAST CORNER AT PERSHING/ RTE. 53)

SUMMARY OF QUANTITIES				CONSTRUCTION TYPE CODE		
CODE NO	ITEM	UNIT	TOTAL QUANTITY	TRAFFIC SIGNALS @ RTE 38 & NICOLL WAY	TRAFFIC SIGNALS @ RTE 53 & PERSHING AVE	TRAFFIC SIGNALS @ RTE 38 & LAMBERT RD
				80 % FED 20% VILLAGE	80 % FED 20% VILLAGE	80 % FED 20% VILLAGE
				0021	0021	0021
20201200	REMOVAL AND DISPOSAL OF UNSUITABLE MATERIAL	CU YD	71		71	
21101615	TOPSOIL FURNISH AND PLACE, 4"	SQ YD	150		150	
25200110	SODDING, SALT TOLERANT	SQ YD	150		150	
25200200	SUPPLEMENTAL WATERING	UNIT	2		2	
* 42400200	PORTLAND CEMENT CONCRETE SIDEWALK, 5 INCH	SQ FT	1870		1870	
* 42400800	DETECTABLE WARNINGS	SQ FT	122		122	
* 44000500	COMBINATION CURB AND GUTTER REMOVAL	FOOT	253	137	116	
* 44201670	CLASS D PATCHES, TYPE 1, 2 INCH	SQ YD	43	23	20	
* 60600605	CONCRETE CURB, TYPE B	FOOT	50	34	16	
* 60604400	COMBINATION CONCRETE CURB AND GUTTER, TYPE B-6.18	FOOT	137	137		
* 60605000	COMBINATION CONCRETE CURB AND GUTTER, TYPE B-6.24	FOOT	116		116	
67100100	MOBILIZATION	L SUM	1	0.4	0.4	0.2
70102635	TRAFFIC CONTROL AND PROTECTION, STANDARD 701701	L SUM	1	0.4	0.4	0.2
70102640	TRAFFIC CONTROL AND PROTECTION, STANDARD 701801	L SUM	1	0.4	0.4	0.2
70103815	TRAFFIC CONTROL SURVEILLANCE	CAL DA	30	15	15	
* 78000400	THERMOPLASTIC PAVEMENT MARKINGS-LINE 6"	FOOT	710	580	0	130
* 78000600	THERMOPLASTIC PAVEMENT MARKINGS-LINE 12"	FOOT	714	582		132
* 78000650	THERMOPLASTIC PAVEMENT MARKINGS-LINE 24"	FOOT	56	56	0	0
* 78001150	PAINT PAVEMENT MARKINGS-LINE 12"	FOOT	600		600	
* 78001180	PAINT PAVEMENT MARKINGS-LINE 24"	FOOT	62		62	
* 78300100	PAVEMENT MARKING REMOVAL	SQ FT	521	379	142	
81028200	UNDERGROUND CONDUIT, GALVANIZED STEEL, 2" DIA.	FOOT	100	86	14	
81028210	UNDERGROUND CONDUIT, GALVANIZED STEEL, 2 1/2" DIA.	FOOT	42		42	
81028240	UNDERGROUND CONDUIT, GALVANIZED STEEL, 4" DIA.	FOOT	202		202	
85000200	MAINTENANCE OF EXISTING TRAFFIC SIGNAL INSTALLATION	EACH	3	1	1	1
85100500	PAINT NEW TRAFFIC SIGNAL POST	EACH	5	5		
87301215	ELECTRIC CABLE IN CONDUIT, SIGNAL NO. 14 2C	FOOT	2850	1260	1244	346
87301225	ELECTRIC CABLE IN CONDUIT, SIGNAL NO. 14 3C	FOOT	1943	269	1316	358

SUMMARY OF QUANTITIES				CONSTRUCTION TYPE CODE		
CODE NO	ITEM	UNIT	TOTAL QUANTITY	TRAFFIC SIGNALS @ RTE 38 & NICOLL WAY	TRAFFIC SIGNALS @ RTE 53 & PERSHING AVE	TRAFFIC SIGNALS @ RTE 38 & LAMBERT RD
				80 % FED 20% VILLAGE	80 % FED 20% VILLAGE	80 % FED 20% VILLAGE
				0021	0021	0021
87301900	ELECTRIC CABLE IN CONDUIT, EQUIPMENT GROUNDING CONDUCTOR, NO. 6 1C	FOOT	100	0	100	0
87502440	TRAFFIC SIGNAL POST, GALVANIZED STEEL 10 FT.	EACH	2		2	
87602000	PEDESTRIAN PUSH BUTTON POST	EACH	6	5	1	
87800100	CONCRETE FOUNDATION, TYPE A	FOOT	36	20	16	
87900200	DRILL EXISTING HANDHOLE	EACH	14	5	9	
88102717	PEDESTRIAN SIGNAL HEAD, LED, 1-FACE, BRACKET MOUNTED WITH COUNTDOWN TIMER	EACH	4	2	0	2
88102747	PEDESTRIAN SIGNAL HEAD, LED, 2-FACE, BRACKET MOUNTED WITH COUNTDOWN TIMER	EACH	4	0	4	0
88600100	DETECTOR LOOP, TYPE 1	FOOT	87		87	
88800100	PEDESTRIAN PUSH-BUTTON	EACH	18	8	8	2
89500100	RELOCATE EXISTING SIGNAL HEAD	EACH	1		1	
89500400	RELOCATE EXISTING PEDESTRIAN PUSH-BUTTON	EACH	3	3		
89501150	RELOCATE EXISTING TRAFFIC SIGNAL POST	EACH	1		1	
89502200	MODIFY EXISTING CONTROLLER	EACH	3	1	1	1
89502350	REMOVE AND REINSTALL ELECTRIC CABLE FROM CONDUIT	FOOT	143	103	40	
89502376	REBUILD EXISTING HANDHOLE	EACH	2	1	1	
89502385	REMOVE EXISTING CONCRETE FOUNDATION	EACH	1		1	
* X0326864	BRICK SIDEWALK REMOVAL	SQ FT	1038	1038		
* X0540000	BRICK PAVERS	SQ FT	200	200		
Z0013798	CONSTRUCTION LAYOUT	L SUM	1	0.4	0.4	0.2
Z0030850	TEMPORARY INFORMATION SIGNING	SQ FT	103	51.5	51.5	
* XX004688	BRICK PAVER SIDEWALK	SQ FT	1038	1038		
* XX007729	DETECTABLE WARNINGS, SPECIAL	SQ FT	124	124		
* 66900200	NON-SPECIAL WASTE DISPOSAL	CU YD	20.0		20	
* 66900450	SPECIAL WASTE PLANS AND REPORTS	L SUM	1		1	
* 66900530	SOIL DISPOSAL ANALYSIS	EACH	1		1	

* SPECIALTY ITEMS



USER NAME =	DESIGNED -- SJG	REVISED -- 10-05-15
PLOT SCALE =	DRAWN -- SMP	REVISED --
PLOT DATE =	CHECKED -- SJG	REVISED --
	DATE -- 1-22-15	REVISED --

**STATE OF ILLINOIS
DEPARTMENT OF TRANSPORTATION**

SUMMARY OF QUANTITIES

SCALE: NONE SHEET NO. OF SHEETS STA. _____ TO STA. _____

F.A.P. RTE. 870 & 347	SECTION 13-00078-00-TL	COUNTY DuPAGE	TOTAL SHEETS 21	SHEET NO. 3
CONTRACT NO. 61A67			ILLINOIS FED. AID PROJECT	



SEE SHEET 6 FOR SIDEWALK CORNER DETAILS

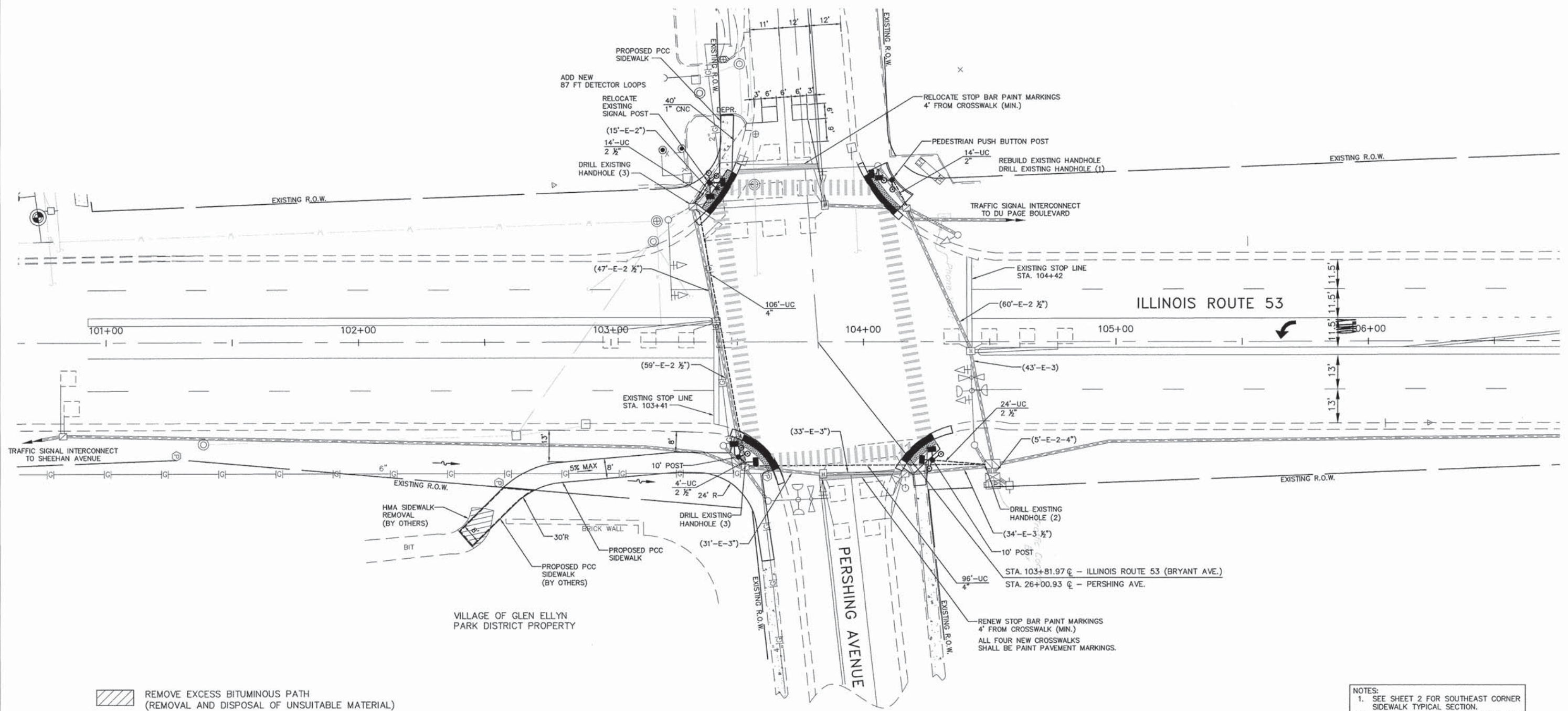

- REMOVE EXCESS BITUMINOUS PATH (REMOVAL AND DISPOSAL OF UNSUITABLE MATERIAL)
- DETECTABLE WARNINGS

NOTES:
 1. SEE SHEET 2 FOR SOUTHEAST CORNER SIDEWALK TYPICAL SECTION.
 2. ALL PROPOSED SIDEWALK GRADES ARE NO GREATER THAN 5.00%.

TS# 20335
 GLEN ELLYN

RTE 53/ PERSHING BASE SURVEY BY CEMCON, LTD.

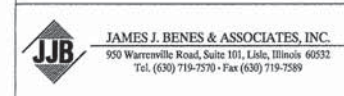

USER NAME =	DESIGNED -- SJG	REVISED --
DRAWN -- SMP	REVISED --	
PLOT SCALE =	CHECKED -- SJG	REVISED --
PLOT DATE =	DATE -- 1-22-15	REVISED --

**STATE OF ILLINOIS
 DEPARTMENT OF TRANSPORTATION**

**TRAFFIC SIGNAL MODERNIZATION PLAN
 ILLINOIS ROUTE 53 AT PERSHING AVENUE**

SCALE: 1"=20' SHEET NO. OF SHEETS STA. _____ TO STA. _____

F.A.P. RTE. 870 & 347	SECTION 13-0078-00-TL	COUNTY DuPAGE	TOTAL SHEETS 21	SHEET NO. 4
CONTRACT NO. 61A67				
ILLINOIS FED. AID PROJECT				

CONTROLLER SEQUENCE

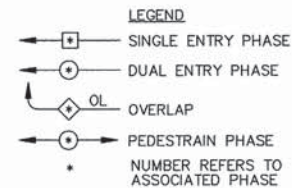
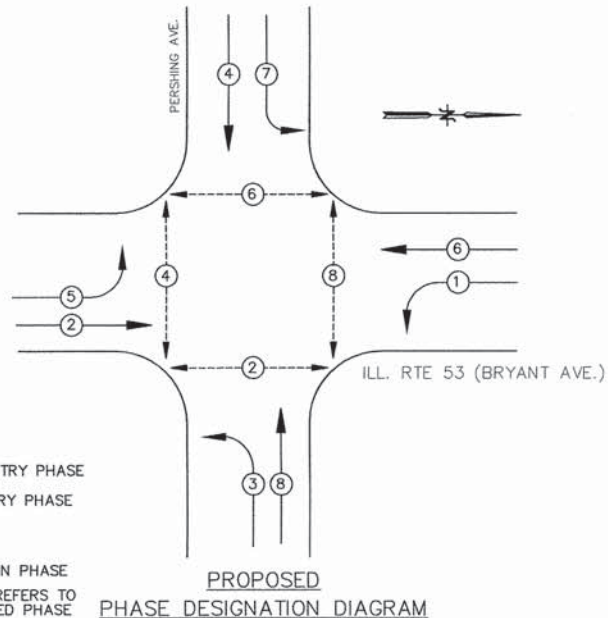

CONTROLLER SEQUENCE

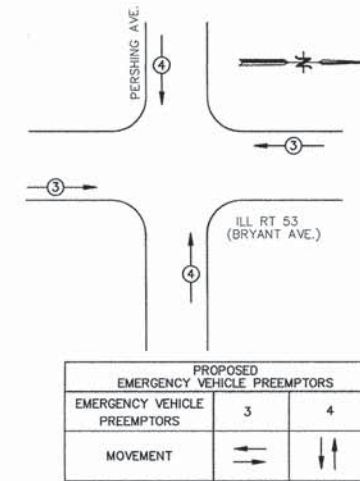
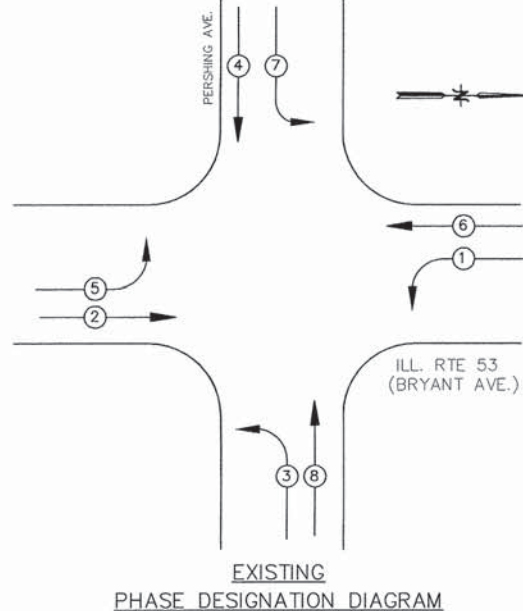

PROPOSED EMERGENCY VEHICLE PREEMPTION SEQUENCE

SCHEDULE OF QUANTITIES

CODE NO	PAY ITEM	UNIT	PERSHING
20201200	REMOVAL AND DISPOSAL OF UNSUITABLE MATERIAL	CU YD	71
21101615	TOPSOIL FURNISH AND PLACE, 4"	SQ YD	150
25200110	SODDING, SALT TOLERANT	SQ YD	150
25200200	SUPPLEMENTAL WATERING	UNIT	2
42400200	PORTLAND CEMENT CONCRETE SIDEWALK, 5 INCH	SQ FT	1870
42400800	DETECTABLE WARNINGS	SQ FT	122
44000500	COMBINATION CURB AND GUTTER REMOVAL	FOOT	116
60600605	CONCRETE CURB, TYPE B	FOOT	16
60605000	COMBINATION CONCRETE CURB AND GUTTER, TYPE B-6.24	FOOT	116
67100100	MOBILIZATION	L SUM	0.4
70102635	TRAFFIC CONTROL AND PROTECTION, STANDARD 701701	L SUM	0.4
70102640	TRAFFIC CONTROL AND PROTECTION, STANDARD 701801	L SUM	0.4
78001130	PAINT PAVMENT MARKINGS-LINE 6"	FOOT	592
78001180	PAINT PAVMENT MARKINGS-LINE 24"	FOOT	62
78300100	PAVEMENT MARKING REMOVAL	SQ FT	142
81028200	UNDERGROUND CONDUIT, GALVANIZED STEEL, 2" DIA.	FOOT	14
81028210	UNDERGROUND CONDUIT, GALVANIZED STEEL, 2 1/2" DIA.	FOOT	42
81028240	UNDERGROUND CONDUIT, GALVANIZED STEEL, 4" DIA.	FOOT	202
85000200	MAINTENANCE OF EXISTING TRAFFIC SIGNAL INSTALLATION	EACH	1
87301215	ELECTRIC CABLE IN CONDUIT, SIGNAL NO. 14 2C	FOOT	1244
87301225	ELECTRIC CABLE IN CONDUIT, SIGNAL NO. 14 3C	FOOT	1316
87301900	ELECTRIC CABLE IN CONDUIT, EQUIPMENT GROUNDING CONDUCTOR, NO. 6 1C	FOOT	100
87502440	TRAFFIC SIGNAL POST, GALVANIZED STEEL 10 FT.	EACH	2
87602000	PEDESTRIAN PUSH BUTTON POST	EACH	1
87800100	CONCRETE FOUNDATION, TYPE A	FOOT	16
87900200	DRILL EXISTING HANDHOLE	EACH	9
88102747	PEDESTRIAN SIGNAL HEAD, LED, 2-FACE, BRACKET MOUNTED WITH COUNTDOWN TIMER	EACH	4
88600100	DETECTOR LOOP, TYPE 1	FOOT	87
88800100	PEDESTRIAN PUSH-BUTTON	EACH	8
89500100	RELOCATE EXISTING SIGNAL HEAD	EACH	1
89501150	RELOCATE EXISTING TRAFFIC SIGNAL POST	EACH	1
89502200	MODIFY EXISTING CONTROLLER	EACH	1
89502350	REMOVE AND REINSTALL ELECTRIC CABLE FROM CONDUIT	FOOT	40
89502376	REBUILD EXISTING HANDHOLE	EACH	1
89502385	REMOVE EXISTING CONCRETE FOUNDATION	EACH	1

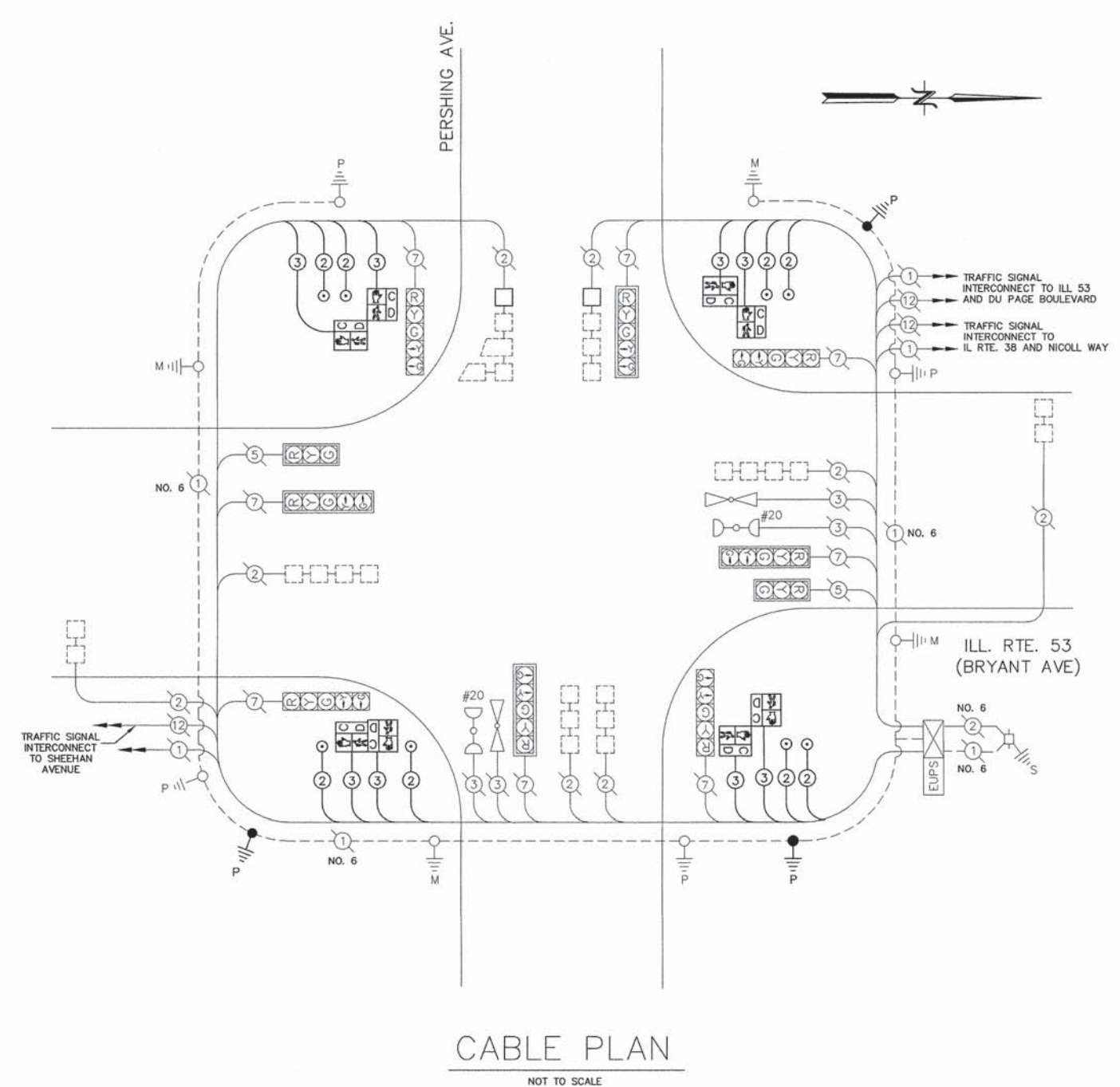

I.D.O.T. TRAFFIC SIGNAL INSTALLATION ELECTRICAL SERVICE REQUIREMENTS

TYPE	NO. LAMPS	WATTAGE		% OPERATION	TOTAL WATTAGE
		INCAND.	LED		
SIGNAL (RED)	10	135	17	0.50	85
(YELLOW)	10	135	25	0.25	63
(GREEN)	10	135	15	0.25	38
ARROW	16	135	12	0.10	19
PED. SIGNAL	8	90	25	1.00	200
CONTROLLER	-	100	100	1.00	100
MASTER CONTROLLER	-	100	100	1.00	-
ILLUM. SIGN	-	252	-	0.05	-
FLASHER	-	-	-	-	-

ENERGY COSTS TO: 50% TO IDOT, 50% TO VILLAGE OF GLEN ELLYN

535 DUANE STREET
GLEN ELLYN, IL 60137

ENERGY SUPPLY CONTACT: DEBBIE RANKIN
PHONE: 630-691-4379
COMPANY: COMMONWEALTH EDISON

TOTAL = 505

JJB JAMES J. BENES & ASSOCIATES, INC.
900 Warrenville Road, Suite 101, Lake, Illinois 60032
Tel. (630) 719-7570 - Fax (630) 719-7589

USER NAME =	DESIGNED -- SJG	REVISED -- 10-05-15
PLOT SCALE =	DRAWN -- SMP	REVISED --
PLOT DATE =	CHECKED -- SJG	REVISED --
	DATE -- 1-22-15	REVISED --

STATE OF ILLINOIS DEPARTMENT OF TRANSPORTATION

SCHEDULE OF QUANTITIES, CABLE PLAN, PHASE DESIGNATION DIAGRAM AND EMERGENCY VEHICLE PREEMPTION SEQUENCE

SCALE: NTS SHEET NO. OF SHEETS STA. TO STA.

F.A.P. RTE. 870 & 347	SECTION 13-00078-00-TL	COUNTY DuPAGE	TOTAL SHEETS 21	SHEET NO. 5
CONTRACT NO. 61A67			ILLINOIS FED. AID PROJECT	

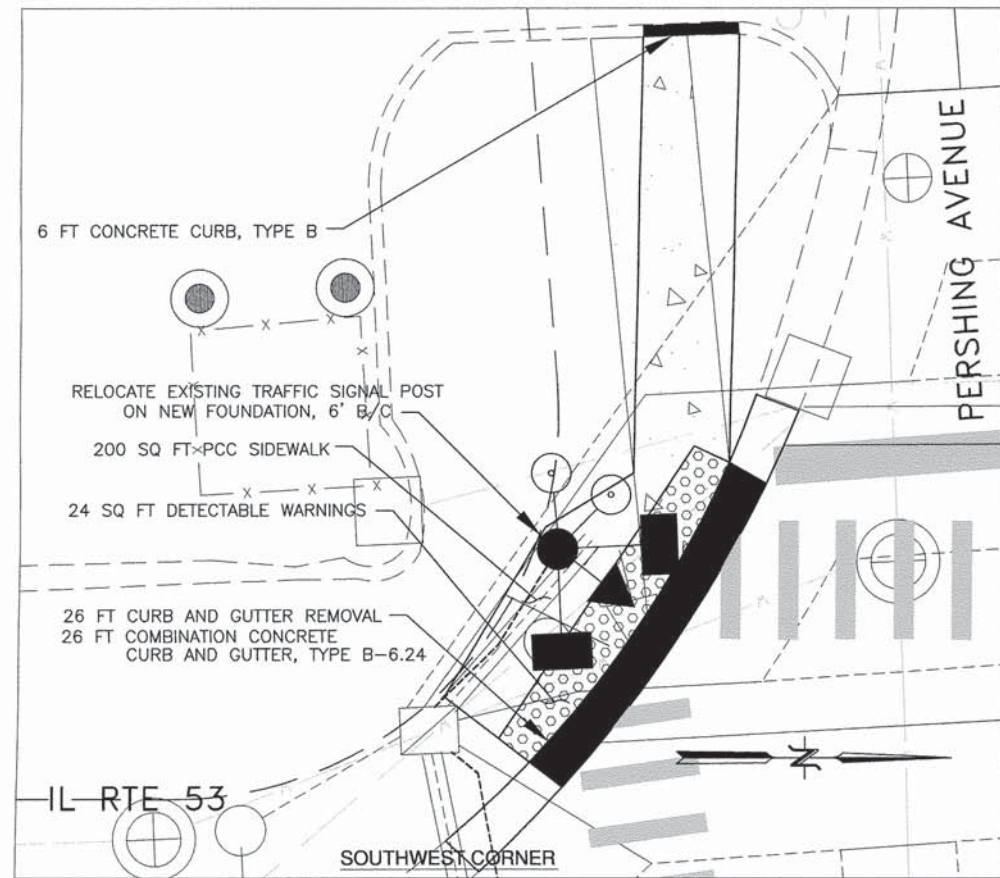

- SYMBOLS
- DEPRESSED CURB
 - ▨ DETECTABLE WARNINGS

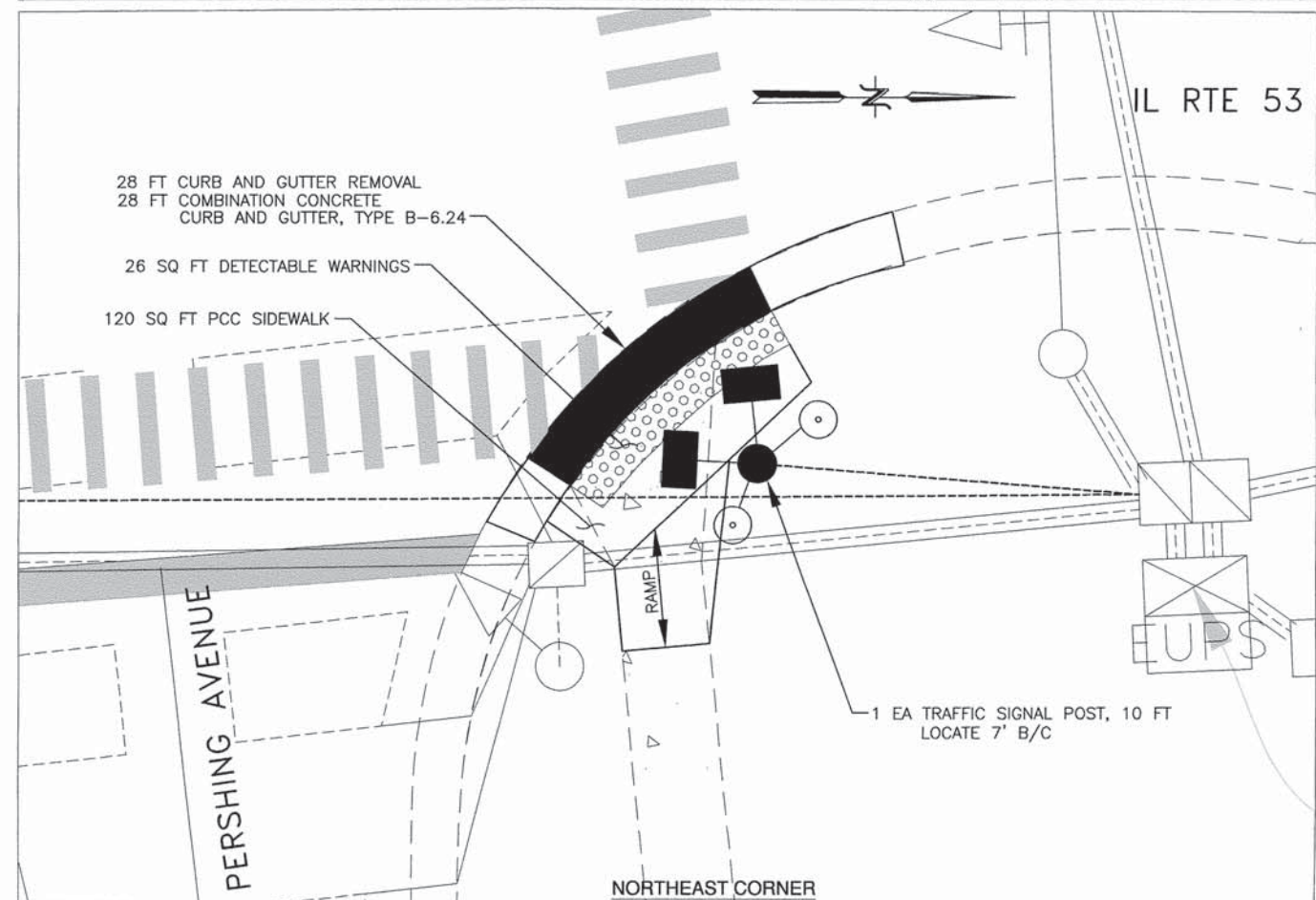
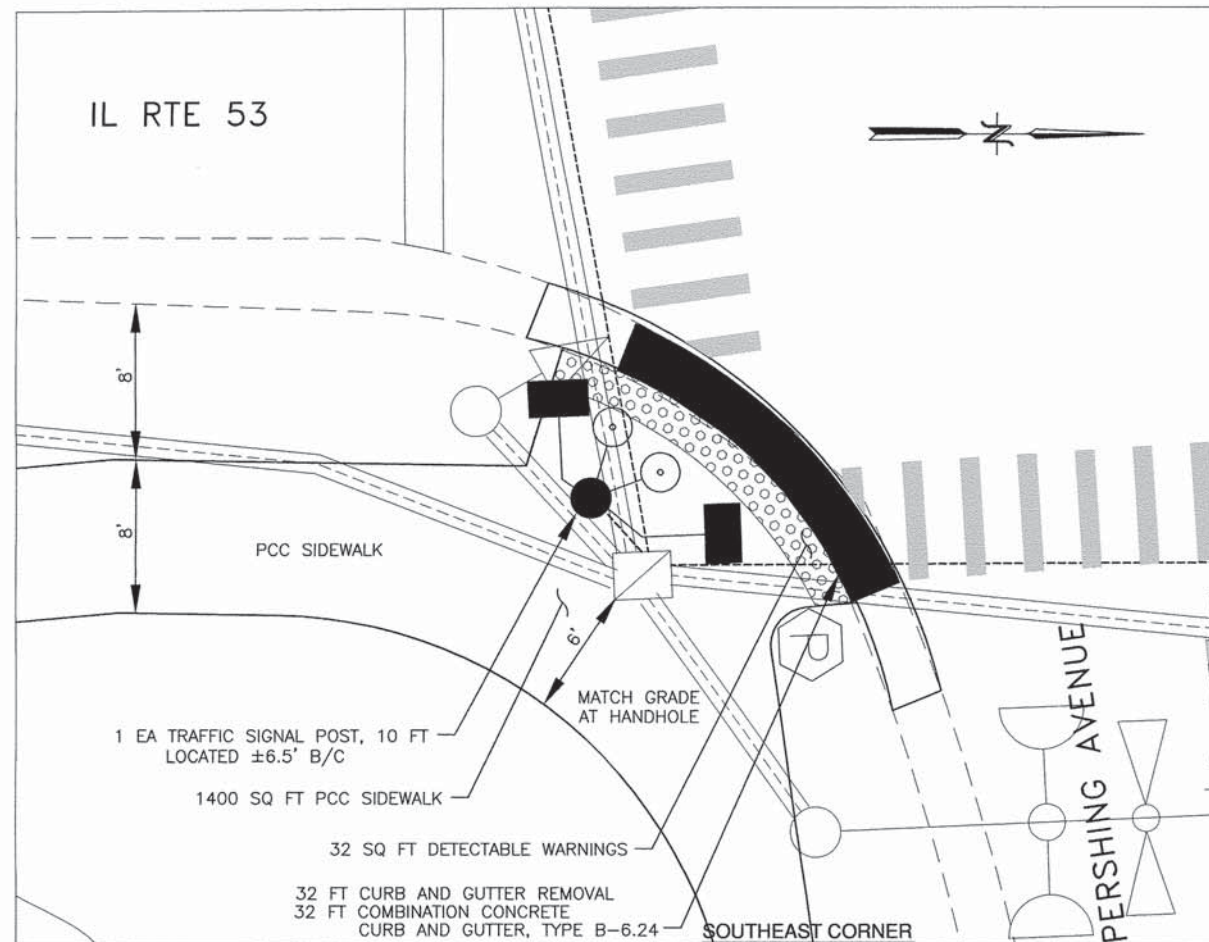
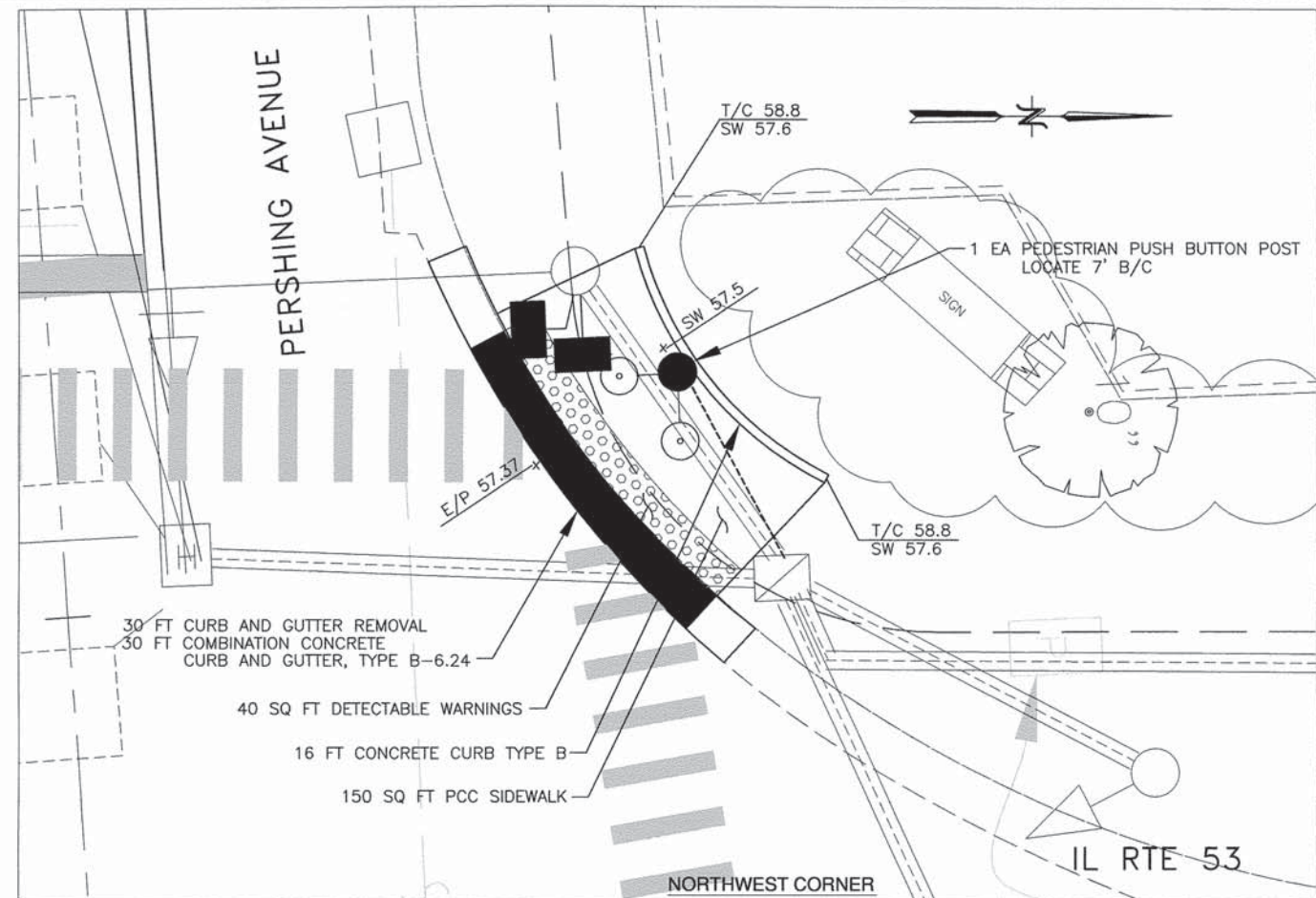

USER NAME =	DESIGNED -- SJG	REVISED --
PLOT SCALE =	DRAWN -- SMP	REVISED --
PLOT DATE =	CHECKED -- SJG	REVISED --
	DATE -- 1-22-15	REVISED --

F.A.P. RTE. 870 & 347	SECTION 13-00078-00-TL	COUNTY DuPAGE	TOTAL SHEETS 21	SHEET NO. 6
ILLINOIS FED. AID PROJECT			CONTRACT NO. 61A67	

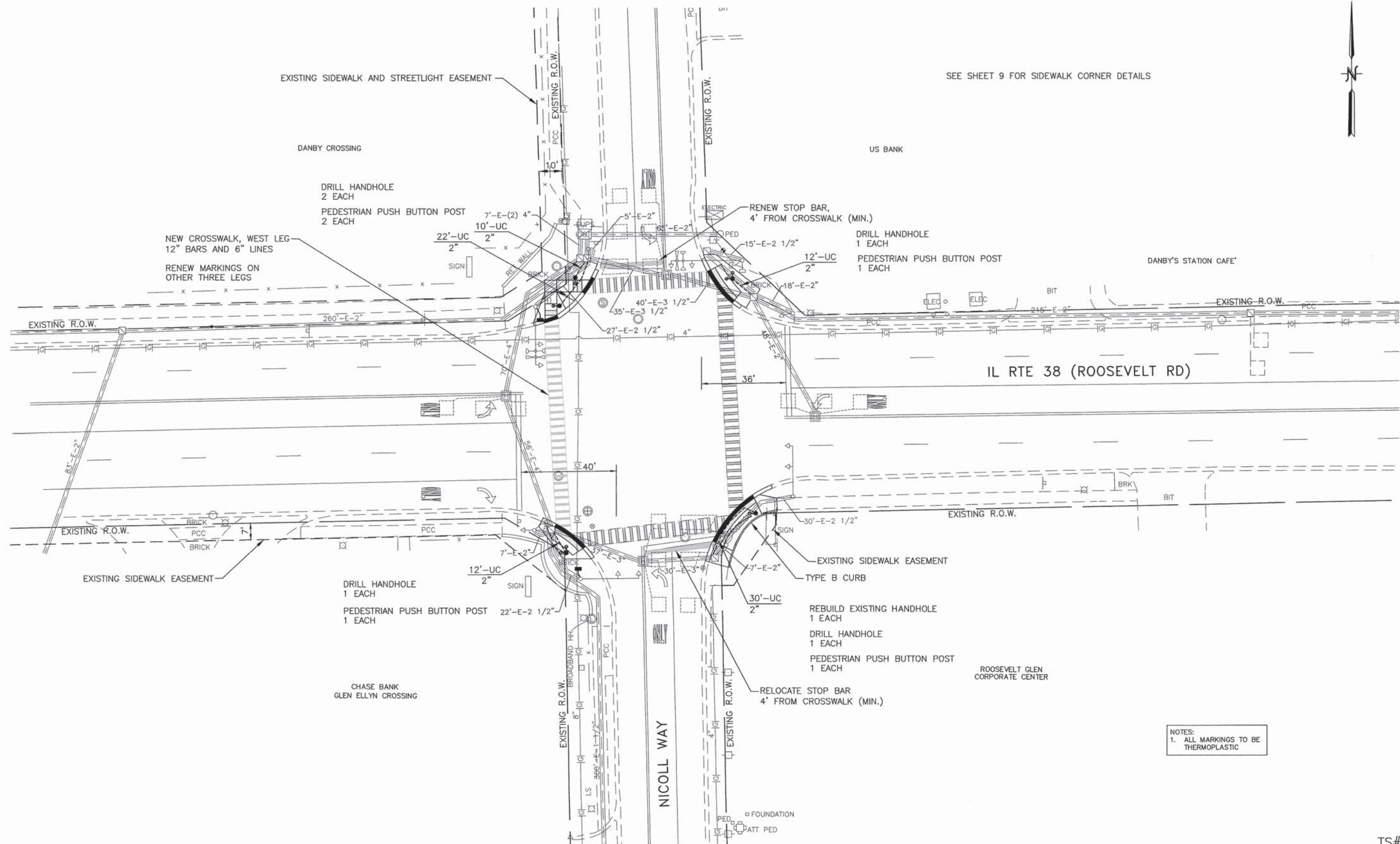

NOTES:
1. ALL MARKINGS TO BE THERMOPLASTIC

JJB
JAMES J. BENES & ASSOCIATES, INC.
950 Warrenville Road, Suite 101, Lisle, Illinois 60532
Tel. (630) 719-7570 - Fax (630) 719-7589

USER NAME =	DESIGNED -- SJG	REVISED --
DRAWN -- SMP	REVISED --	
PLOT SCALE =	CHECKED -- SJG	REVISED --
PLOT DATE =	DATE -- 1-22-15	REVISED --

**STATE OF ILLINOIS
DEPARTMENT OF TRANSPORTATION**

**TRAFFIC SIGNAL MODERNIZATION PLAN
ILLINOIS ROUTE 38 AT NICOLL WAY**

SCALE: 1"=20' SHEET NO. OF SHEETS STA. _____ TO STA. _____

F.A.P. RTE. 870 & 347	SECTION 13-00078-00-TL	COUNTY DuPAGE	TOTAL SHEETS 21	SHEET NO. 7
CONTRACT NO. 61A67			ILLINOIS FED. AID PROJECT	

TS# 20361
GLEN ELLYN

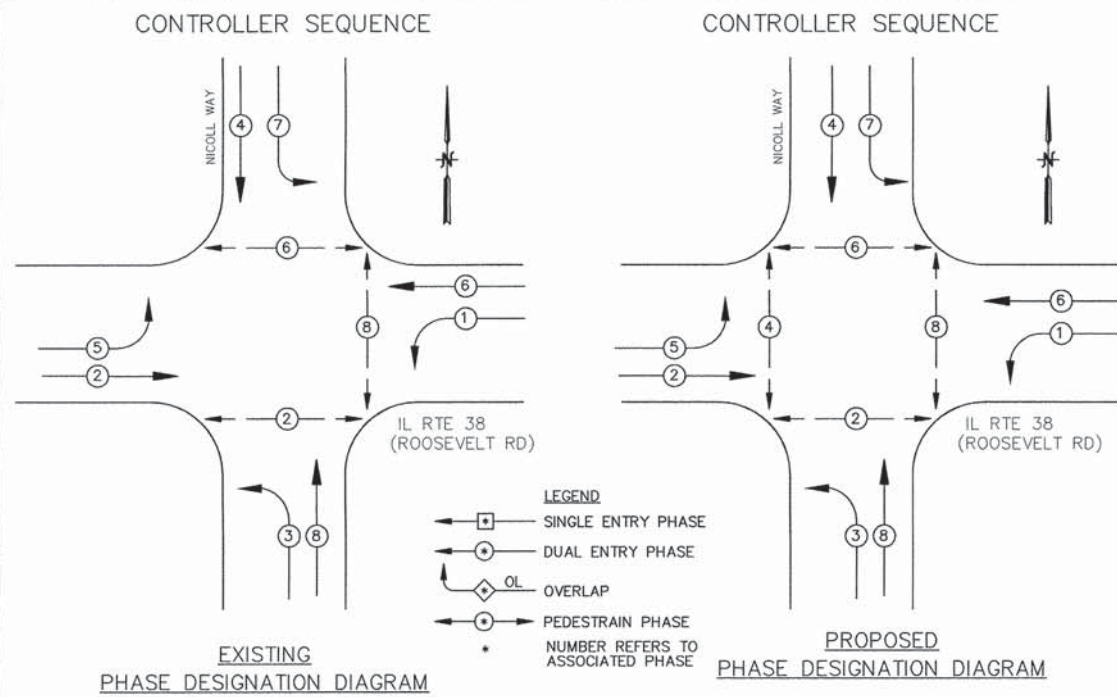

EXISTING PHASE DESIGNATION DIAGRAM

PROPOSED PHASE DESIGNATION DIAGRAM

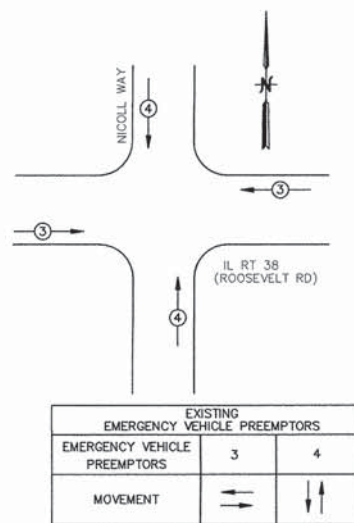

EXISTING EMERGENCY VEHICLE PREEMPTION SEQUENCE

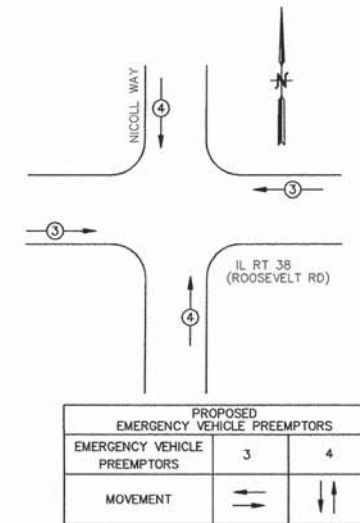

PROPOSED EMERGENCY VEHICLE PREEMPTION SEQUENCE

SCHEDULE OF QUANTITIES

CODE NO	PAY ITEM	UNIT	NICOLL
44000500	COMBINATION CURB AND GUTTER REMOVAL	FOOT	137
60600605	CONCRETE CURB, TYPE B	FOOT	24
60604400	COMBINATION CONCRETE CURB AND GUTTER, TYPE B-6.18	FOOT	137
67100100	MOBILIZATION	L SUM	0.4
70102635	TRAFFIC CONTROL AND PROTECTION, STANDARD 701701	L SUM	0.4
70102640	TRAFFIC CONTROL AND PROTECTION, STANDARD 701801	L SUM	0.4
78000400	THERMOPLASTIC PAVEMENT MARKINGS-LINE 6"	FOOT	176
78000600	THERMOPLASTIC PAVEMENT MARKINGS-LINE 12"	FOOT	174
78000650	THERMOPLASTIC PAVEMENT MARKINGS-LINE 24"	FOOT	56
78300100	PAVEMENT MARKING REMOVAL	SQ FT	112
81028200	UNDERGROUND CONDUIT, GALVANIZED STEEL, 2" DIA.	FOOT	86
85000200	MAINTENANCE OF EXISTING TRAFFIC SIGNAL INSTALLATION	EACH	1
85100500	PAINT NEW TRAFFIC SIGNAL POST	EACH	5
87301215	ELECTRIC CABLE IN CONDUIT, SIGNAL NO. 14 2C	FOOT	1260
87301225	ELECTRIC CABLE IN CONDUIT, SIGNAL NO. 14 3C	FOOT	1411
87602000	PEDESTRIAN PUSH BUTTON POST	EACH	5
87800100	CONCRETE FOUNDATION, TYPE A	FOOT	20
87900200	DRILL EXISTING HANDHOLE	EACH	5
88102717	PEDESTRIAN SIGNAL HEAD, LED, 1-FACE, BRACKET MOUNTED WITH COUNTDOWN TIMER	EACH	2
88102747	PEDESTRIAN SIGNAL HEAD, LED, 2-FACE, BRACKET MOUNTED WITH COUNTDOWN TIMER	EACH	3
88800100	PEDESTRIAN PUSH-BUTTON	EACH	8
89502200	MODIFY EXISTING CONTROLLER	EACH	1
89502375	REMOVE EXISTING TRAFFIC SIGNAL EQUIPMENT	EACH	1
89502376	REBUILD EXISTING HANDHOLE	EACH	1
X0326864	BRICK SIDEWALK REMOVAL	SQ FT	1038
X0540000	BRICK PAVERS	SQ FT	200
XX004688	BRICK PAVER SIDEWALK	SQ FT	1038
XX007729	DETECTABLE WARNINGS (SPECIAL)	SQ FT	124

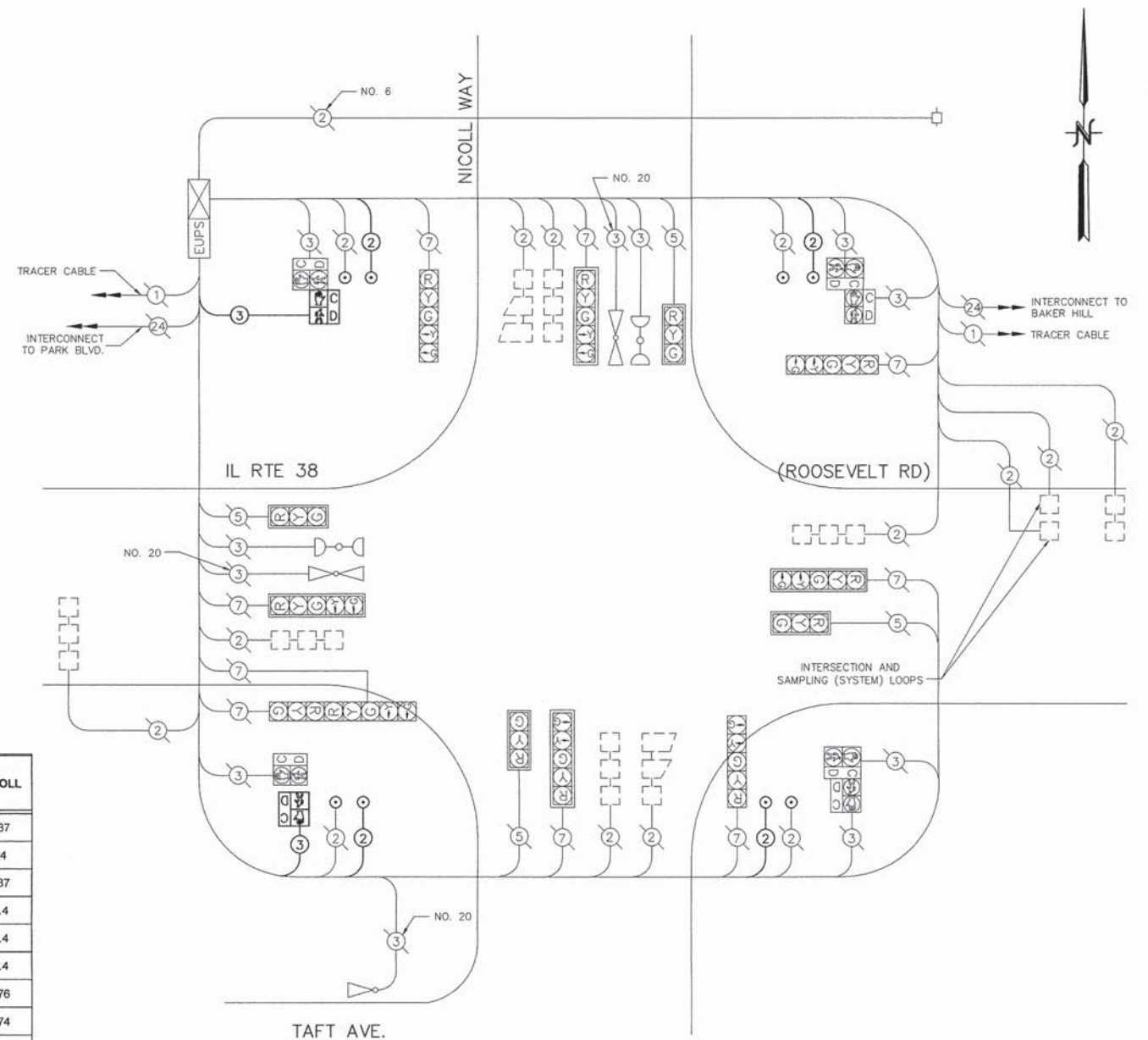

I.D.O.T. TRAFFIC SIGNAL INSTALLATION ELECTRICAL SERVICE REQUIREMENTS					TOTAL WATTAGE
TYPE	NO. LAMPS	WATTAGE INCAND.	LED	% OPERATION	
SIGNAL (RED)	13	135	17	0.50	111
(YELLOW)	13	135	25	0.25	81
(GREEN)	13	135	15	0.25	49
ARROW	18	135	12	0.10	22
PED. SIGNAL	8	90	25	1.00	200
CONTROLLER	-	100	100	1.00	100
MASTER CONTROLLER	-	100	100	1.00	-
ILLUM. SIGN	-	252		0.05	-
FLASHER					
ENERGY COSTS TO: 50% TO IDOT 50% TO VILLAGE OF GLEN ELLYN 535 DUANE STREET GLEN ELLYN, IL 60137					TOTAL = 563
ENERGY SUPPLY CONTACT: DEBBIE RANKIN PHONE: 630-691-4379 COMPANY: COMMONWEALTH EDISON					

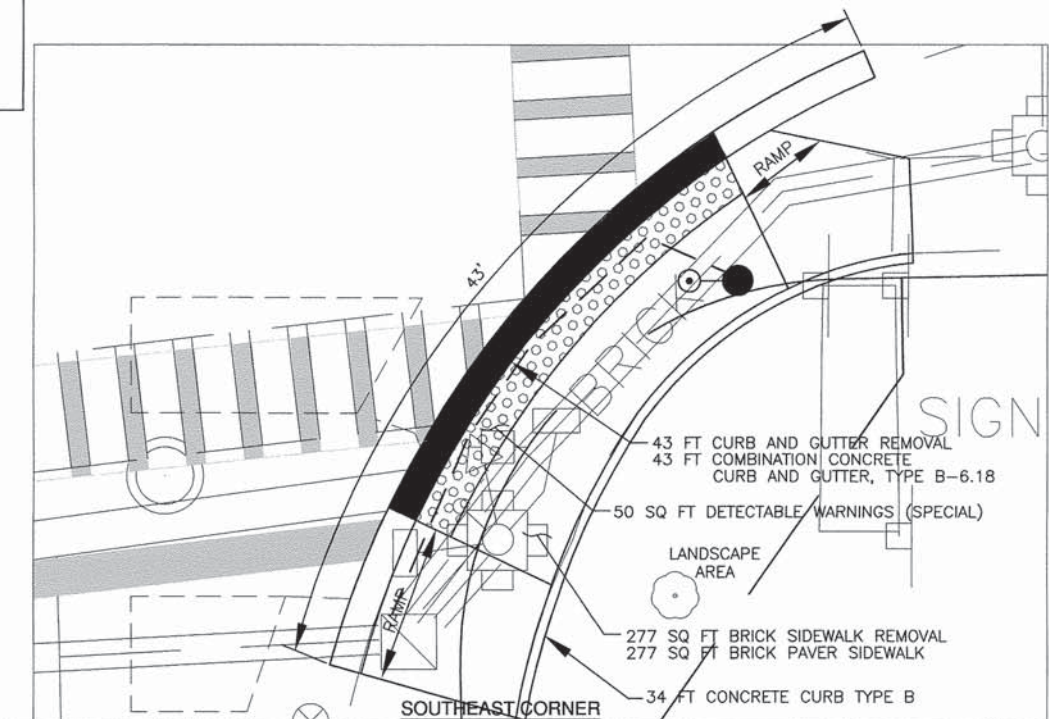
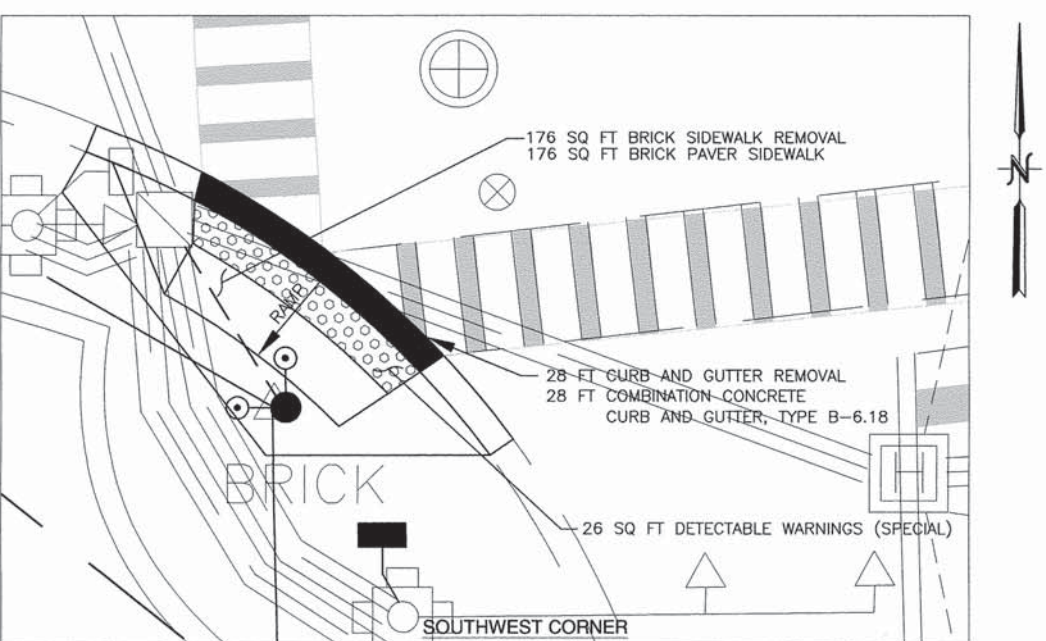
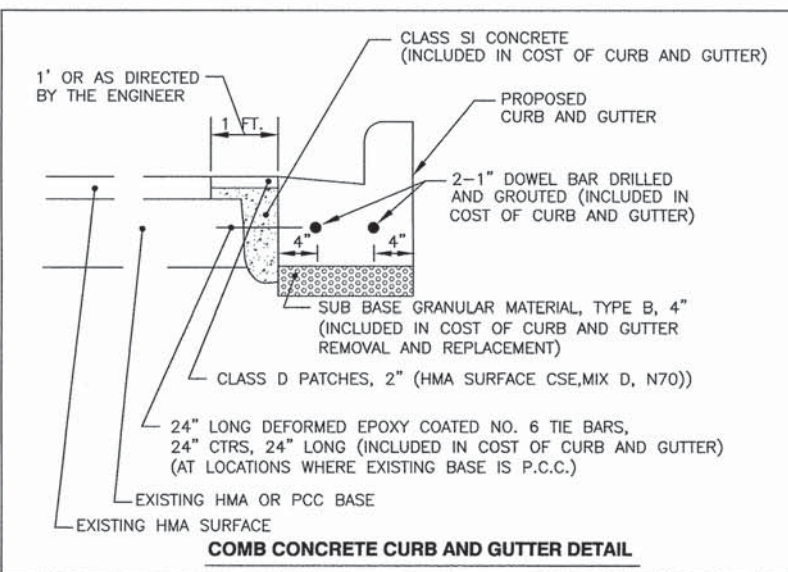
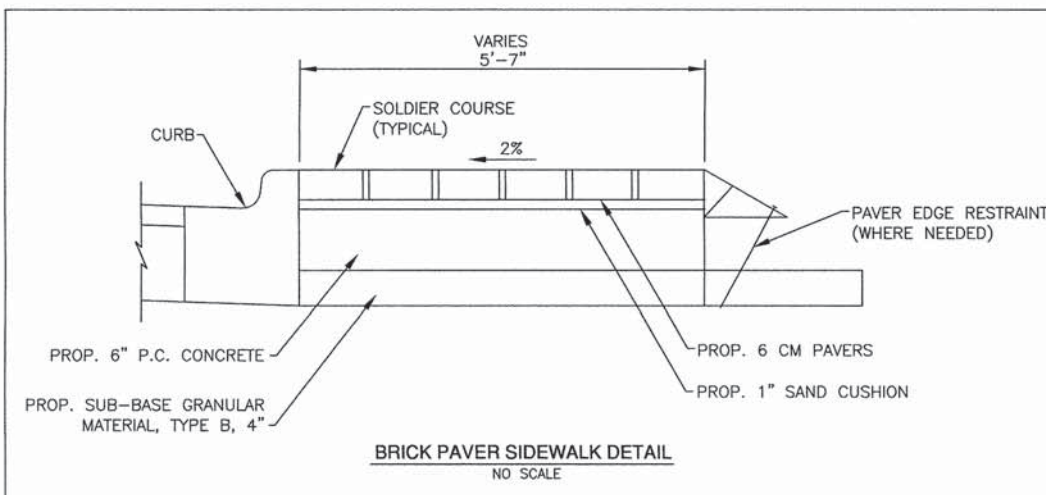
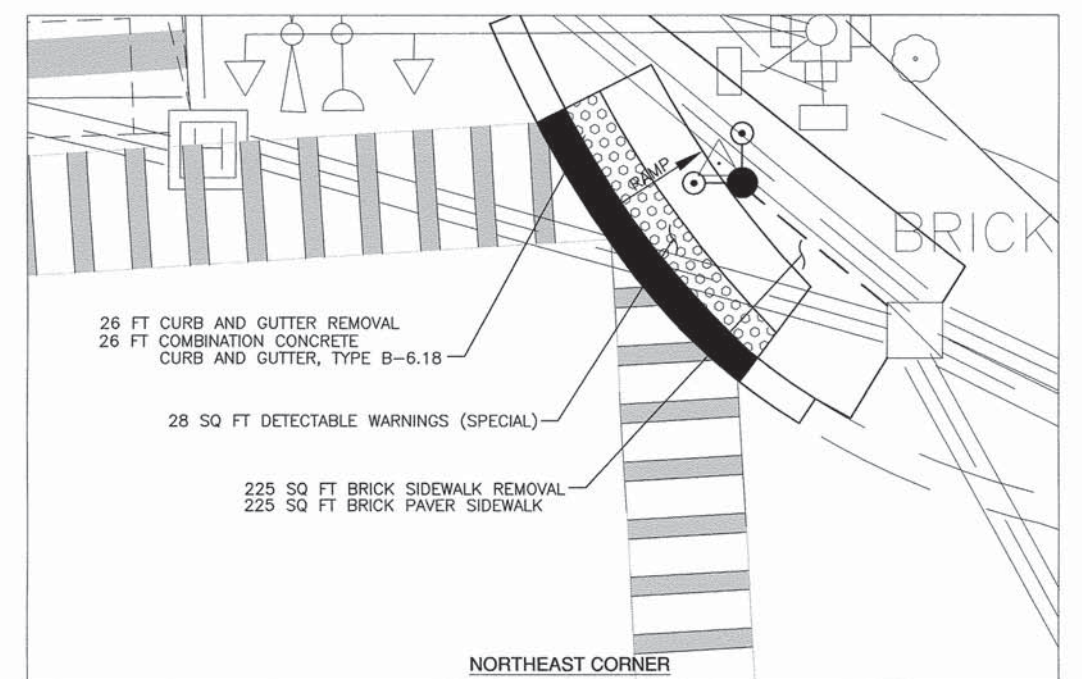
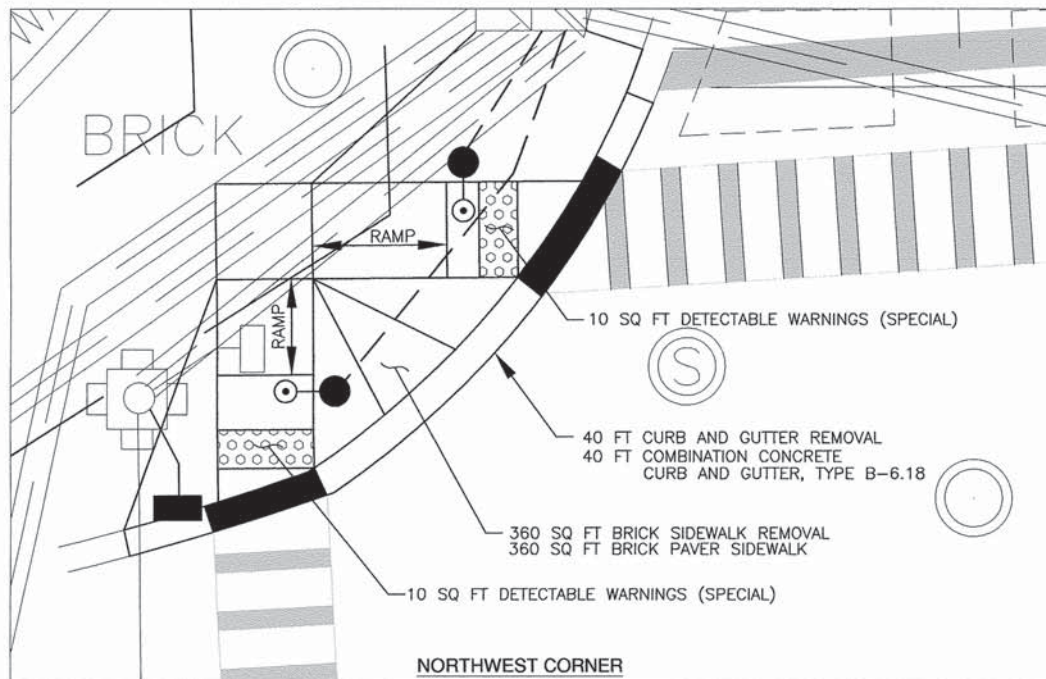

SCALE: 1" = 20'

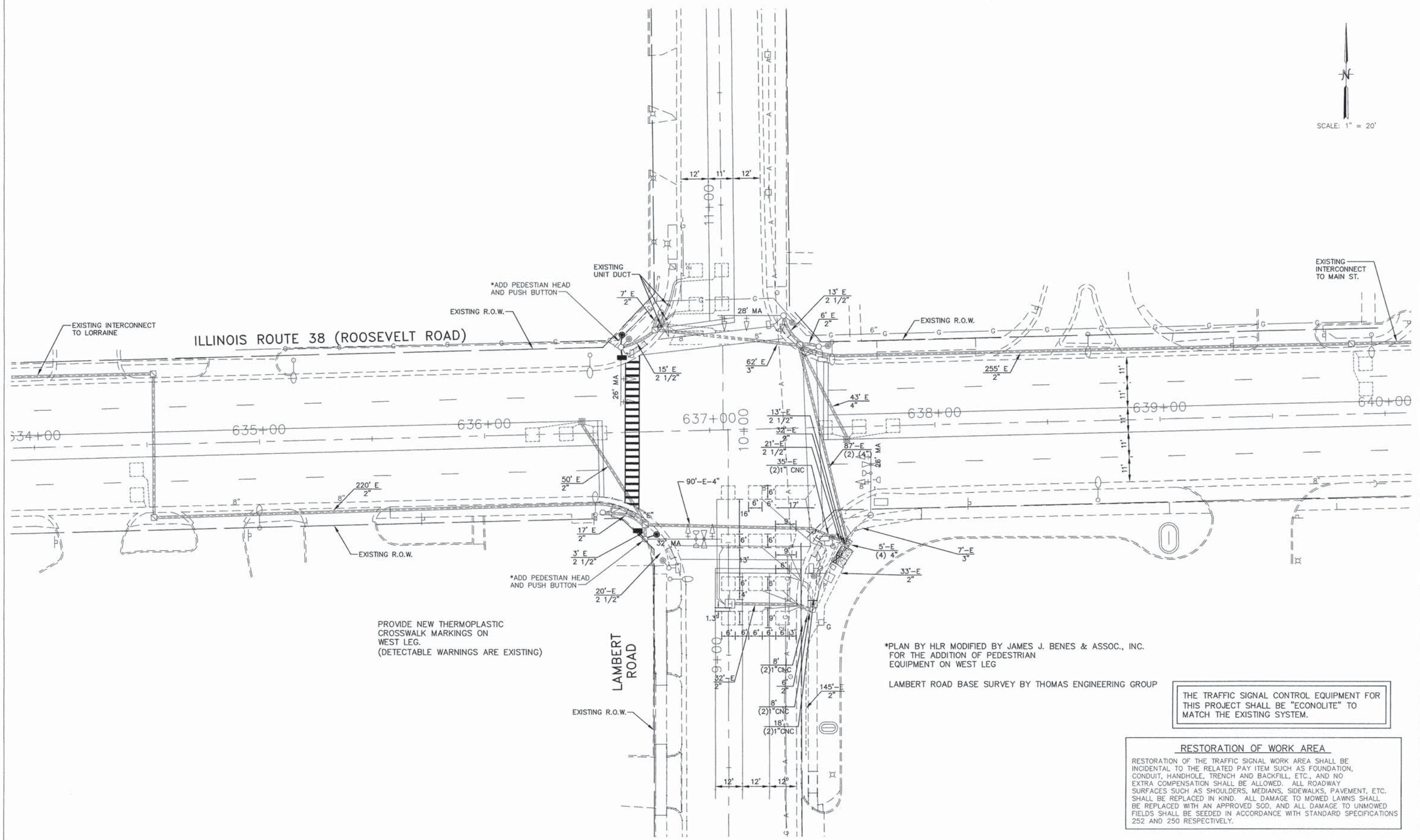

PROVIDE NEW THERMOPLASTIC CROSSWALK MARKINGS ON WEST LEG. (DETECTABLE WARNINGS ARE EXISTING)

*PLAN BY HLR MODIFIED BY JAMES J. BENES & ASSOC., INC. FOR THE ADDITION OF PEDESTRIAN EQUIPMENT ON WEST LEG

LAMBERT ROAD BASE SURVEY BY THOMAS ENGINEERING GROUP

THE TRAFFIC SIGNAL CONTROL EQUIPMENT FOR THIS PROJECT SHALL BE "ECONOLITE" TO MATCH THE EXISTING SYSTEM.

RESTORATION OF WORK AREA
 RESTORATION OF THE TRAFFIC SIGNAL WORK AREA SHALL BE INCIDENTAL TO THE RELATED PAY ITEM SUCH AS FOUNDATION, CONDUIT, HANDHOLE, TRENCH AND BACKFILL, ETC., AND NO EXTRA COMPENSATION SHALL BE ALLOWED. ALL ROADWAY SURFACES SUCH AS SHOULDERS, MEDIANS, SIDEWALKS, PAVEMENT, ETC. SHALL BE REPLACED IN KIND. ALL DAMAGE TO MOWED LAWNS SHALL BE REPLACED WITH AN APPROVED SOD, AND ALL DAMAGE TO UNMOWED FIELDS SHALL BE SEEDING IN ACCORDANCE WITH STANDARD SPECIFICATIONS 252 AND 250 RESPECTIVELY.

JJB
 JAMES J. BENES & ASSOCIATES, INC.
 900 Warrville Road, Suite 101, Lake, Illinois 60532
 Tel. (630) 719-7570 - Fax (630) 719-7589

USER NAME =	DESIGNED — SJG	REVISED —
DRAWN — SMP	REVISED —	
PLOT SCALE =	CHECKED — SJG	REVISED —
PLOT DATE =	DATE — 1-22-15	REVISED —

**STATE OF ILLINOIS
 DEPARTMENT OF TRANSPORTATION**

**TRAFFIC SIGNAL MODERNIZATION
 ILLINOIS ROUTE 38 AND LAMBERT ROAD**

SCALE: NONE SHEET NO. OF SHEETS STA. _____ TO STA. _____

F.A.P. RTE. 870 & 347	SECTION 13-00078-00-TL	COUNTY DuPAGE	TOTAL SHEETS 21	SHEET NO. 10
CONTRACT NO. 61A67			ILLINOIS FED. AID PROJECT	

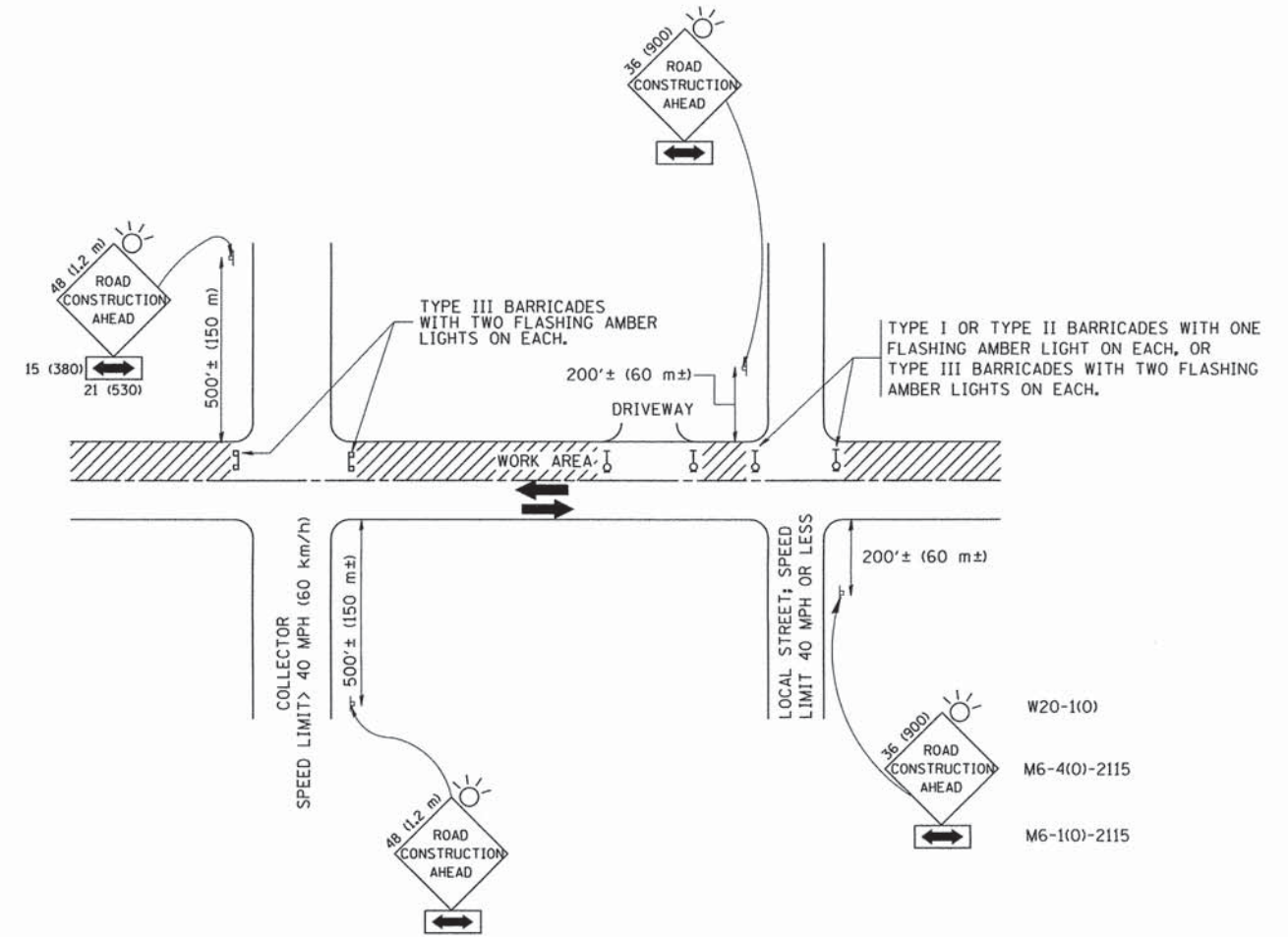

TRAFFIC CONTROL AND PROTECTION FOR SIDE ROADS, INTERSECTIONS, AND DRIVEWAYS

NOTES:

- A. FOR NO LANE RESTRICTION ON THE SIDE ROAD OR DRIVEWAYS
- SIDE ROAD WITH A SPEED LIMIT OF 40 MPH (60 km/h) OR LESS AS SHOWN ON THE DRAWING AND AS DIRECTED BY THE ENGINEER:
 - ONE ROAD CONSTRUCTION AHEAD SIGN 36 x 36 (900x900) WITH A FLASHER AND FLAG MOUNTED ON IT APPROXIMATELY 200' (60 m) IN ADVANCE OF THE MAIN ROUTE.
 - THE CLOSED PORTION OF THE MAIN ROUTE SHALL BE PROTECTED BY BLOCKING WITH TYPE I, TYPE II OR TYPE III BARRICADES, 1/3 OF THE CROSS SECTION OF THE CLOSED PORTION.
 - SIDE ROAD WITH A SPEED LIMIT GREATER THAN 40 MPH (60 km/h) AS SHOWN ON THE DRAWING AND AS DIRECTED BY THE ENGINEER:
 - ONE ROAD CONSTRUCTION AHEAD SIGN 48 x 48 (1.2 m x 1.2 m) WITH A FLASHER MOUNTED ON IT APPROXIMATELY 500' (150 m) IN ADVANCE OF THE MAIN ROUTE.
 - THE CLOSED PORTION OF THE MAIN ROUTE SHALL BE PROTECTED BY BLOCKING WITH TYPE III BARRICADES, 1/2 OF THE CROSS SECTION OF THE CLOSED PORTION.
 - WHEN THE SIDE ROAD LIES BETWEEN THE BEGINNING OF THE MAINLINE SIGNING AND THE WORK ZONE, A SINGLE HEADED ARROW (M6-1) SHALL BE USED IN LIEU OF THE DOUBLE HEADED ARROW (M6-4).
- B. FOR A LANE CLOSURE ON A SIDE ROAD OR DRIVEWAY:
- USE APPLICABLE PORTIONS OF THE TYPICAL APPLICATION OF TRAFFIC CONTROL DEVICES (STD. 701501, STD. 701606 OR THE APPROPRIATE STANDARD). THE SPACING OF SIGNS AND BARRICADES SHALL BE ADJUSTED FOR FIELD CONDITIONS AS DIRECTED BY THE ENGINEER. THE DIRECTIONAL ARROW SHALL BE COVERED OR REMOVED WHEN NO LONGER CONSISTENT WITH THE SIDE ROAD LANE CLOSURE.
- C. ADVANCE WARNING SIGNS ARE TO BE OMITTED ON DRIVEWAY UNLESS OTHERWISE NOTED.
- D. THE TRAFFIC CONTROL AND PROTECTION FOR SIDE ROADS, INTERSECTIONS, AND DRIVEWAYS SHALL BE INCIDENTAL TO THE COST OF SPECIFIED TRAFFIC CONTROL STANDARDS OR ITEMS.

All dimensions are in millimeters (inches) unless otherwise shown.

FILE NAME = W:\dststd\22x34\to10.dgn	USER NAME = goglianobt	DESIGNED - LHA	REVISED - J. OBERLE 10-18-95
		DRAWN -	REVISED - A. HOUSEH 03-06-96
	PLOT SCALE = 50.000' / IN.	CHECKED -	REVISED - A. HOUSEH 10-15-96
	PLOT DATE = 1/4/2008	DATE - 06-89	REVISED - T. RAMMACHER 01-06-00

STATE OF ILLINOIS
DEPARTMENT OF TRANSPORTATION

TRAFFIC CONTROL AND PROTECTION FOR
SIDE ROADS, INTERSECTIONS, AND DRIVEWAYS

SCALE: NONE SHEET NO. 1 OF 1 SHEETS STA. TO STA.

F.A.P. RTE. 870 & 347	SECTION 13-00078-00-TL	COUNTY DuPAGE	TOTAL SHEETS 21	SHEET NO. 12
TC-10		CONTRACT NO. 61A67		
FED. ROAD DIST. NO. 1 ILLINOIS FED. AID PROJECT				

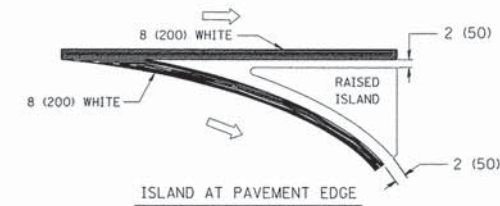
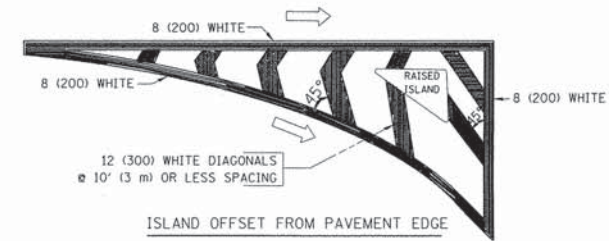
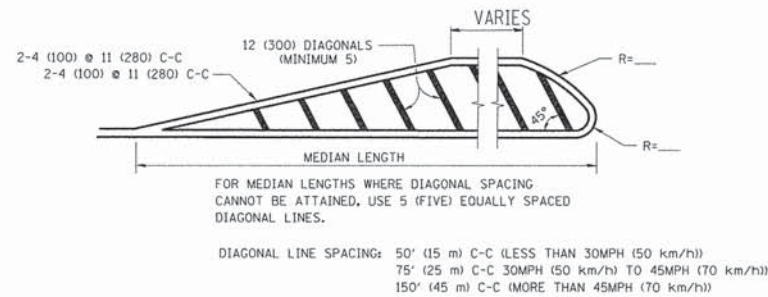
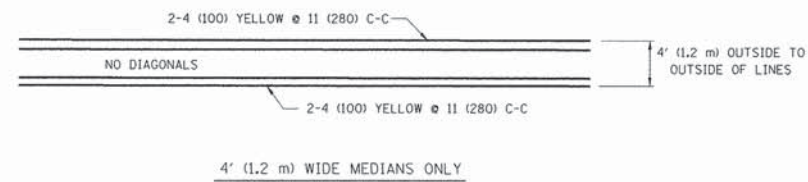
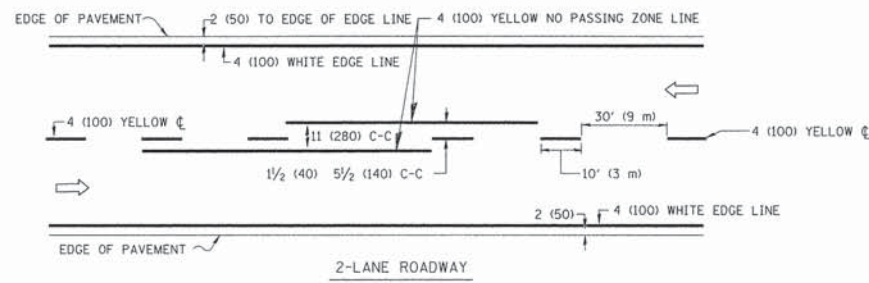

TYPICAL ISLAND MARKING

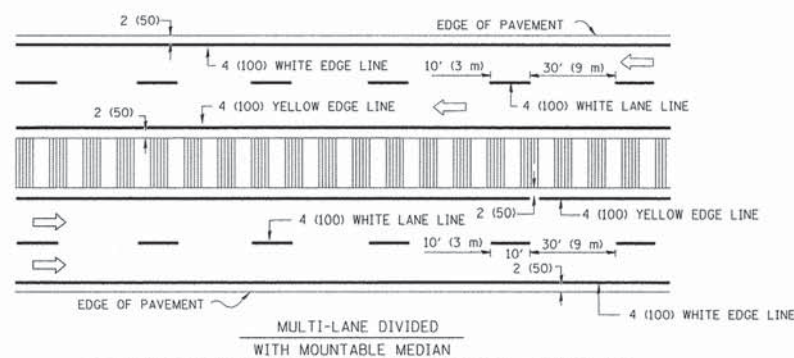
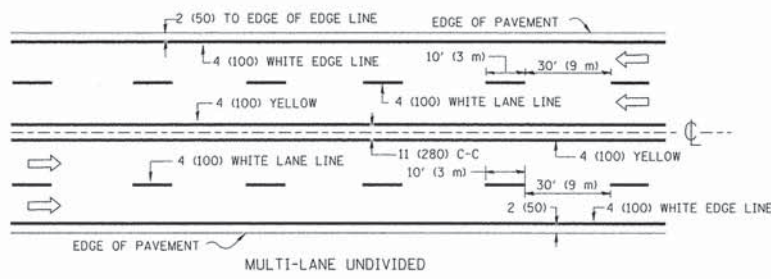

NOTE: MEDIANS WITH BARRIER CURB DO NOT REQUIRE AN EDGE LINE

TYPICAL LANE AND EDGE LINE MARKING

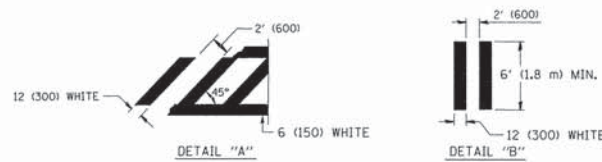
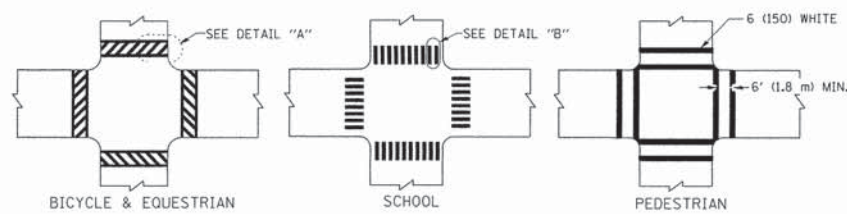

TYPICAL CROSSWALK MARKING

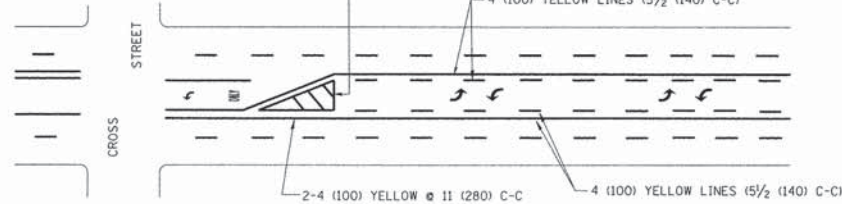

A MINIMUM OF TWO PAIRS OF TURN ARROWS SHALL BE USED, WHITE IN COLOR. ADDITIONAL PAIRS SHALL BE PLACED AT 200' (60 m) TO 300' (90 m) INTERVALS.

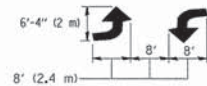

MEDIAN WITH TWO-WAY LEFT TURN LANE

TYPICAL PAINTED MEDIAN MARKING

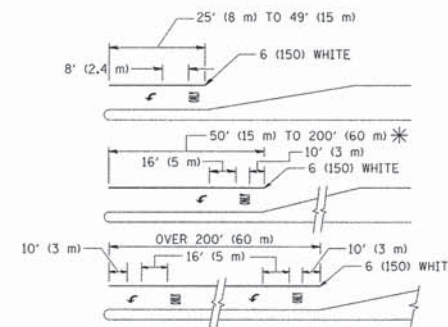

FULL SIZE LETTERS 8" (2.4 m) AND ARROWS SHALL BE USED.
AREA = 15.6 SQ. FT. (1.5 m²) ONLY AREA = 20.8 SQ. FT. (1.9 m²)

* TURN LANES IN EXCESS OF 400' (120 m) IN LENGTH MAY HAVE AN ADDITIONAL SET OF ARROW - "ONLY" INSTALLED MIDWAY BETWEEN THE OTHER TWO SETS OF ARROW - "ONLY".

TYPICAL LEFT (OR RIGHT) TURN LANE

TYPICAL TURN LANE MARKING

TYPE OF MARKING	WIDTH OF LINE	PATTERN	COLOR	SPACING / REMARKS
CENTERLINE ON 2 LANE PAVEMENT	4 (100)	SKIP-DASH	YELLOW	10' (3 m) LINE WITH 30' (9 m) SPACE
CENTERLINE ON MULTI-LANE UNDIVIDED PAVEMENT	2 @ 4 (100)	SOLID	YELLOW	11 (280) C-C
NO PASSING ZONE LINES: FOR ONE DIRECTION	4 (100)	SOLID	YELLOW	5 1/2 (140) C-C FROM SKIP-DASH CENTERLINE
FOR BOTH DIRECTIONS	2 @ 4 (100)	SOLID	YELLOW	11 (280) C-C OMIT SKIP-DASH CENTERLINE BETWEEN
LANE LINES	4 (100) 5 (125) ON FREEWAYS	SKIP-DASH SKIP-DASH	WHITE WHITE	10' (3 m) LINE WITH 30' (9 m) SPACE
DOTTED LINES (EXTENSIONS OF CENTER, LANE OR TURN LANE MARKINGS)	SAME AS LINE BEING EXTENDED	SKIP-DASH	SAME AS LINE BEING EXTENDED	2' (600) LINE WITH 6' (1.8 m) SPACE
EDGE LINES	4 (100)	SOLID	YELLOW-LEFT WHITE-RIGHT	OUTLINE MOUNTABLE MEDIANS IN YELLOW; EDGE LINES ARE NOT USED NEXT TO BARRIER CURB
TURN LANE MARKINGS	6 (150) LINE; FULL SIZE LETTERS & SYMBOLS (8' (2.4m))	SOLID	WHITE	SEE TYPICAL TURN LANE MARKING DETAIL
TWO WAY LEFT TURN MARKING	2 @ 4 (100) EACH DIRECTION	SKIP-DASH AND SOLID	YELLOW	10' (3 m) LINE WITH 30' (9 m) SPACE FOR SKIP-DASH; 5 1/2 (140) C-C BETWEEN SOLID LINE AND SKIP-DASH LINE
	8' (2.4m) LEFT ARROW	IN PAIRS	WHITE	SEE TYPICAL TWO-WAY LEFT TURN MARKING DETAIL
CROSSWALK LINES (PEDESTRIAN) A. DIAGONALS (BIKE & EQUESTRIAN) B. LONGITUDINAL BARS (SCHOOL)	2 @ 6 (150) 12 (300) @ 45° 12 (300) @ 90°	SOLID SOLID SOLID	WHITE WHITE WHITE	NOT LESS THAN 6' (1.8 m) APART 2' (600) APART 2' (600) APART SEE TYPICAL CROSSWALK MARKING DETAILS.
STOP LINES	24 (600)	SOLID	WHITE	PLACE 4' (1.2 m) IN ADVANCE OF AND PARALLEL TO CROSSWALK, IF PRESENT. OTHERWISE, PLACE AT DESIRED STOPPING POINT. PARALLEL TO CROSSROAD CENTERLINE, WHERE POSSIBLE
PAINTED MEDIANS	2 @ 4 (100) WITH 12 (300) DIAGONALS @ 45°	SOLID	YELLOW; TWO WAY TRAFFIC WHITE; ONE WAY TRAFFIC	11 (280) C-C FOR THE DOUBLE LINE SEE TYPICAL PAINTED MEDIAN MARKING.
GORE MARKING AND CHANNELIZING LINES	8 (200) WITH 12 (300) DIAGONALS @ 45°	SOLID	WHITE	DIAGONALS: 15' (4.5 m) C-C (LESS THAN 30MPH (50 km/h)) 20' (6 m) C-C 30MPH (50 km/h) TO 45MPH (70 km/h) 30' (9 m) C-C (OVER 45MPH (70 km/h))
RAILROAD CROSSING	24 (600) TRANSVERSE LINES; "RR" 15' 6" (4.8 m) LETTERS; 16 (400) LINE FOR "X"	SOLID	WHITE	SEE STATE STANDARD 780001 AREA OF: "R"=3.6 SQ. FT. (0.33 m ²) EACH "X"=54.0 SQ. FT. (5.0 m ²)
SHOULDER DIAGONALS	12 (300) @ 45°	SOLID	WHITE - RIGHT YELLOW - LEFT	50' (15 m) C-C (LESS THAN 30MPH (50 km/h)) 75' (25 m) C-C (30 MPH (50 km/h) TO 45MPH (70 km/h)) 150' (45 m) C-C (OVER 45MPH (70 km/h))

FOR FURTHER DETAILS ON PAVEMENT MARKING REFER TO STANDARD SPECIFICATIONS FOR ROAD AND BRIDGE CONSTRUCTION AND STATE STANDARD 780001.

All dimensions are in inches (millimeters) unless otherwise shown.

FILE NAME =	USER NAME = drvakosgn	DESIGNED - EVERS	REVISED -T. RAMMACHER 10-27-94
c:\pw_work\pawdot\drvakosgn\d0108315\to3.dgn		DRAWN -	REVISED -C. JUCIUS 09-09-09
PLOT SCALE = 50.000 "/ IN.		CHECKED -	REVISED -
PLOT DATE = 9/9/2009		DATE = 03-19-90	REVISED -

STATE OF ILLINOIS
DEPARTMENT OF TRANSPORTATION

DISTRICT ONE		F.A.P. RTE.	SECTION	COUNTY	TOTAL SHEETS	SHEET NO.
TYPICAL PAVEMENT MARKINGS		870 & 347	13-00078-00-TL	DuPAGE	21	13
SCALE: NONE		TC-13		CONTRACT NO. 61A67		
SHEET NO. 1 OF 1 SHEETS		FED. ROAD DIST. NO. 1 ILLINOIS		FED. AID PROJECT		

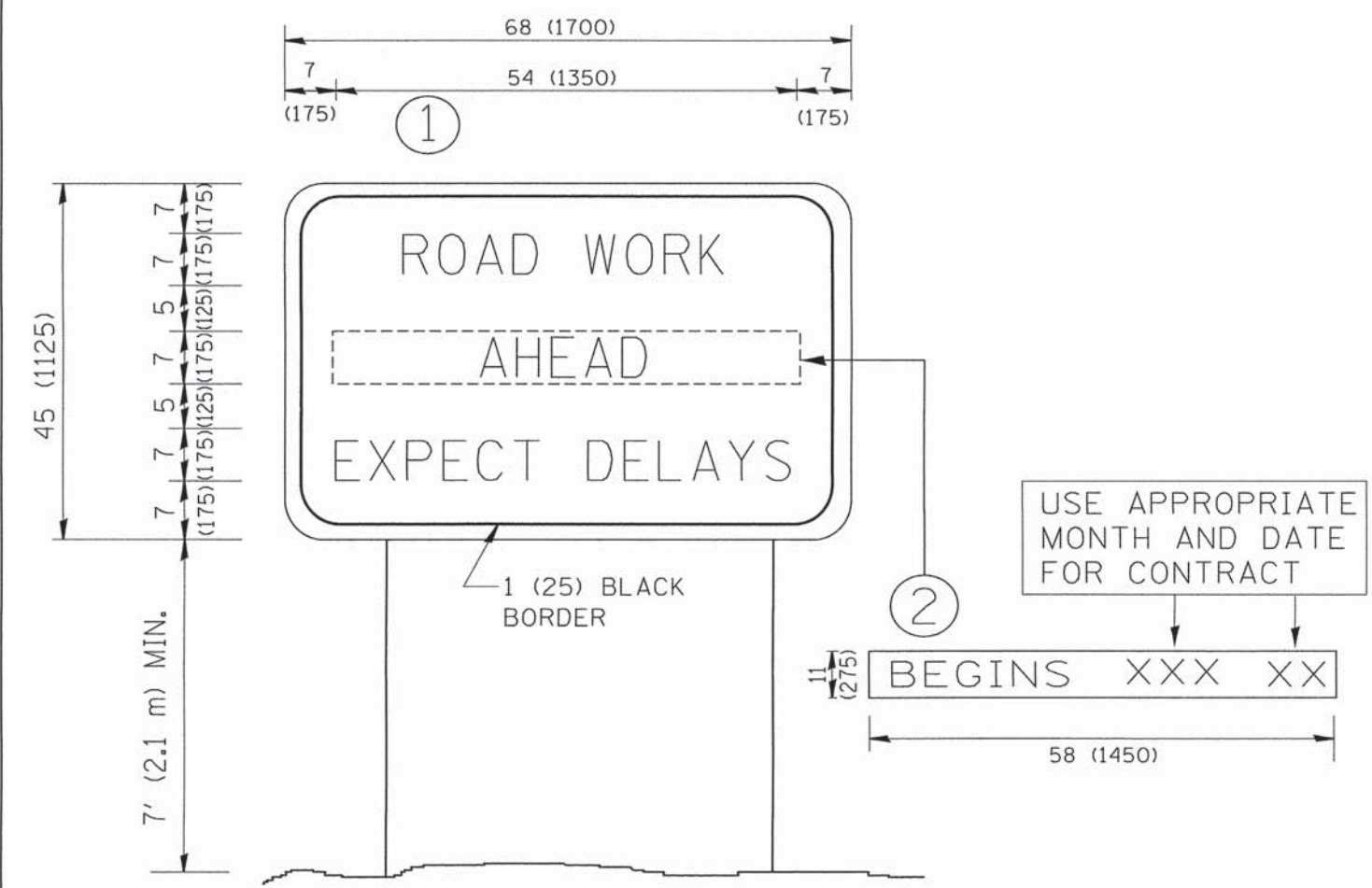

NOTES:

1. USE BLACK LETTERING ON ORANGE BACKGROUND.
2. ERECT SIGNS IN ADVANCE OF THE LOCATION FOR THE "ROAD CONSTRUCTION AHEAD" SIGN AT LOCATIONS AS DIRECTED BY THE ENGINEER.
3. ERECT SIGN ① WITH INSTALLED PANEL ② ONE WEEK PRIOR TO THE START OF CONSTRUCTION.
4. REMOVE PANEL ② SOON AFTER THE START OF CONSTRUCTION.
5. SEE SPECIAL PROVISION FOR "TEMPORARY INFORMATION SIGNING" FOR ADDITIONAL INFORMATION.
6. ONE SIGN ASSEMBLY EQUALS 25.70 SQ. FT. (2.3 SQ. M.)
7. SHALL BE PAID FOR AS TEMPORARY INFORMATION SIGNING.

ALL DIMENSIONS ARE IN INCHES (MILLIMETERS) UNLESS OTHERWISE SHOWN.

FILE NAME = W:\diststd\22x34\to22.dgn	USER NAME = geglianobt	DESIGNED - DRAWN -	REVISED - REVISED -
	PLOT SCALE = 50.000 ' / IN.	CHECKED -	REVISED -
	PLOT DATE = 1/4/2008	DATE -	REVISED -

**STATE OF ILLINOIS
DEPARTMENT OF TRANSPORTATION**

ARTERIAL ROAD INFORMATION SIGN		
SCALE: NONE	SHEET NO. 1 OF 1 SHEETS	STA. TO STA.

F.A.P. RTE. 870 & 347	SECTION 13-00078-00-TL	COUNTY DUPAGE	TOTAL SHEETS 21	SHEET NO. 14
TC-22		CONTRACT NO. 61A67		
FED. ROAD DIST. NO. 1 ILLINOIS FED. AID PROJECT				

TRAFFIC SIGNAL LEGEND

ITEM	REMOVAL	EXISTING	PROPOSED	ITEM	REMOVAL	EXISTING	PROPOSED	ITEM	REMOVAL	EXISTING	PROPOSED
CONTROLLER CABINET				EMERGENCY VEHICLE LIGHT DETECTOR				ELECTRIC CABLE IN CONDUIT, TRACER, NO. 14 1/C, UNLESS NOTED OTHERWISE			
RAILROAD CONTROL CABINET				CONFIRMATION BEACON				COAXIAL CABLE			
COMMUNICATIONS CABINET				HANDHOLE				VENDOR CABLE FOR CAMERA			
MASTER CONTROLLER				HEAVY DUTY HANDHOLE				COPPER INTERCONNECT CABLE, NO. 18 3 PAIR TWISTED, SHIELDED			
MASTER MASTER CONTROLLER				DOUBLE HANDHOLE				FIBER OPTIC CABLE NO. 62.5/125, MM12F			
UNINTERRUPTABLE POWER SUPPLY				JUNCTION BOX				FIBER OPTIC CABLE NO. 62.5/125, MM12F SM12F			
SERVICE INSTALLATION, (P) POLE OR (G) GROUND MOUNT				UNDERGROUND CONDUIT, GALVANIZED STEEL (UC)				FIBER OPTIC CABLE NO. 62.5/125, MM12F SM24F			
TELEPHONE CONNECTION (P) POLE OR (G) GROUND MOUNT				TEMPORARY SPAN WIRE, TETHER WIRE, AND CABLE				FIBER OPTIC CABLE NO. 62.5/125, MM12F SM24F			
STEEL MAST ARM ASSEMBLY AND POLE				COMMON TRENCH				GROUND ROD AT (C) CONTROLLER, (H) HANDHOLE, (P) POST, (M) MAST ARM, OR (S) SERVICE			
ALUMINUM MAST ARM ASSEMBLY AND POLE				COILABLE NONMETALLIC CONDUIT (EMPTY)				CONTROLLER CABINET AND FOUNDATION TO BE REMOVED			
STEEL COMBINATION MAST ARM ASSEMBLY AND POLE WITH LUMINAIRE				SYSTEM ITEM				STEEL MAST ARM POLE AND FOUNDATION TO BE REMOVED			
STEEL COMBINATION MAST ARM ASSEMBLY AND POLE WITH PTZ CAMERA				INTERSECTION ITEM				ALUMINUM MAST ARM POLE AND FOUNDATION TO BE REMOVED			
SIGNAL POST				REMOVE ITEM				STEEL COMBINATION MAST ARM ASSEMBLY AND POLE WITH LUMINAIRE AND FOUNDATION TO BE REMOVED			
TEMPORARY WOOD POLE (CLASS 5 OR BETTER) 45 FOOT (13.7m) MINIMUM				RELOCATE ITEM				SIGNAL POST AND FOUNDATION TO BE REMOVED			
GUY WIRE				ABANDON ITEM				INTERSECTION & SAMPLING (SYSTEM) DETECTOR			
SIGNAL HEAD				12" (300mm) TRAFFIC SIGNAL SECTION				SAMPLING (SYSTEM) DETECTOR			
SIGNAL HEAD CONSTRUCTION STAGES (NUMBERS INDICATE THE CONSTRUCTION STAGE)				12" (300mm) RED WITH 8" (200mm) YELLOW AND GREEN TRAFFIC SIGNAL FACE				QUEUE DETECTOR			
SIGNAL HEAD WITH BACKPLATE				SIGNAL FACE				PREFORMED QUEUE DETECTOR			
SIGNAL HEAD OPTICALLY PROGRAMMED				SIGNAL FACE WITH BACKPLATE, "P" INDICATES PROGRAMMED HEAD				PREFORMED INTERSECTION AND SAMPLING (SYSTEM) DETECTOR			
FLASHER INSTALLATION (S DENOTES SOLAR POWER)				"RB" INDICATES REFLECTIVE BACKPLATE				PREFORMED SAMPLING (SYSTEM) DETECTOR			
PEDESTRIAN SIGNAL HEAD				12" (300mm) PEDESTRIAN SIGNAL HEAD WALK/DON'T WALK SYMBOL							
PEDESTRIAN PUSHBUTTON DETECTOR				12" (300mm) PEDESTRIAN SIGNAL HEAD INTERNATIONAL SYMBOL, OUTLINED							
ACCESSIBLE PEDESTRIAN PUSHBUTTON DETECTOR				12" (300mm) PEDESTRIAN SIGNAL HEAD INTERNATIONAL SYMBOL, SOLID							
ILLUMINATED SIGN "NO LEFT TURN"				PEDESTRIAN SIGNAL HEAD, INTERNATIONAL SYMBOL, WITH COUNTDOWN TIMER							
ILLUMINATED SIGN "NO RIGHT TURN"				RADIO INTERCONNECT							
DETECTOR LOOP, TYPE I				RADIO REPEATER							
PREFORMED DETECTOR LOOP				DENOTES NUMBER OF CONDUCTORS, ELECTRIC CABLE NO. 14, UNLESS NOTED OTHERWISE, ALL DETECTOR LOOP CABLE TO BE SHIELDED							
MICROWAVE VEHICLE SENSOR				GROUND CABLE IN CONDUIT NO. 6 SOLID COPPER (GREEN)							
VIDEO DETECTION CAMERA											
VIDEO DETECTION ZONE											
PAN, TILT, ZOOM CAMERA											
WIRELESS DETECTOR SENSOR											
WIRELESS ACCESS POINT											

RAILROAD SYMBOLS

	EXISTING	PROPOSED
RAILROAD CONTROL CABINET		
RAILROAD CANTILEVER MAST ARM		
FLASHING SIGNAL		
CROSSING GATE		
CROSSBUCK		

LOOP DETECTOR NOTES

1. EACH PAIR OF LOOP WIRES SHALL BE PLACED IN A SEPARATE EMPTY COILABLE NONMETALLIC CONDUIT FROM THE EDGE OF PAVEMENT TO THE HANDHOLE. SPACING BETWEEN THE HOLES DRILLED IN THE PAVEMENT SHALL NOT BE LESS THAN 6" (150 mm). EMPTY COILABLE NONMETALLIC CONDUIT SHALL BE INCLUDED IN THE COST OF THE LOOP WIRE.
2. THE NUMBER OF LOOP TURNS SHALL BE AS RECOMMENDED BY THE AMPLIFIER MANUFACTURER. ALL ADJACENT SIDES OF THE LOOPS SHALL BE INSTALLED IN SUCH A WAY THAT THE CURRENT FLOW IS IN THE SAME DIRECTION TO REINFORCE ITS MAGNETIC FIELDS FOR SMALL VEHICLE DETECTION.
3. EACH LOOP LEAD-IN SHALL BE IDENTIFIED AND PERMANENTLY TAGGED IN THE HANDHOLE. EACH LEAD-IN CABLE TAG SHALL INDICATE THE LOCATION OF THE LOOP, LOOP ROTATION (CLOCKWISE/COUNTERCLOCKWISE), LOOP LEAD-IN DIRECTION (IN OR OUT), LOOP CABLE NUMBER AND LOCATION IN CABINET, AND NUMBER OF TURNS IN THE DETECTOR LOOPS IN WATER PROOF INK AS INDICATED ON THE DISTRICT 1 STANDARD TRAFFIC SIGNAL DESIGN DETAIL. THE CONTRACTOR SHALL MARK LOOP LOCATIONS ON RECORD DRAWINGS AND PRESENT TO THE ENGINEER AFTER FINAL INSPECTION. LOOPS SHALL BE MARKED BY LANE AND LOOP NUMBER. SEE DETAIL BELOW.
4. ALL LOOP CABLE SHALL BE FASTENED WITH PLASTIC TIE WRAP TO THE HANDHOLE HOOKS.
5. IN ASPHALT PAVEMENT, LOOPS SHOULD BE PLACED IN THE BINDER AND DIVESHOLES MARKED AT THE CURB WITH A SAW-CUT. THE SAW-CUT SHALL BE CUT IN ACCORDANCE WITH LOCAL AND E.P.A. DUST CONTROL REQUIREMENTS. DETECTOR LOOP(S) SHALL NOT BE INSTALLED IN WET CONDITIONS AND THE SAW-CUTS MUST BE FREE OF DEBRIS AND RESIDUE SUCH AS DUST AND WATER WHICH IS TO BE ACHIEVED BY THE USE OF COMPRESSED AIR, WIRE BRUSHING AND HEAT DRYING ACCORDING TO SEALANT MANUFACTURER REQUIREMENTS. THE DETECTOR WIRE SHALL BE HELD IN PLACE BY THE USE OF FORM WEDGES. WEDGES SHALL BE SPACED NO MORE THAN 18" (450 mm) APART.
6. LOOP SPLICES SHALL BE SOLDERED USING A SOLDERING IRON. BLOW TORCHES OR OTHER DEVICES WHICH OXIDIZE COPPER CABLE SHALL NOT BE ALLOWED FOR SOLDERING OPERATIONS. SEE DETAIL BELOW RIGHT.
7. PREFORMED DETECTOR LOOPS SHALL BE USED, AS SHOWN ON THE PLANS, WHERE NEW CONCRETE PAVEMENT IS PROPOSED. THE INSTALLATION OF PREFORMED LOOPS SHALL BE IN ACCORDANCE WITH THE DISTRICT 1 SPECIFICATIONS OR AS DIRECTED BY THE ENGINEER.

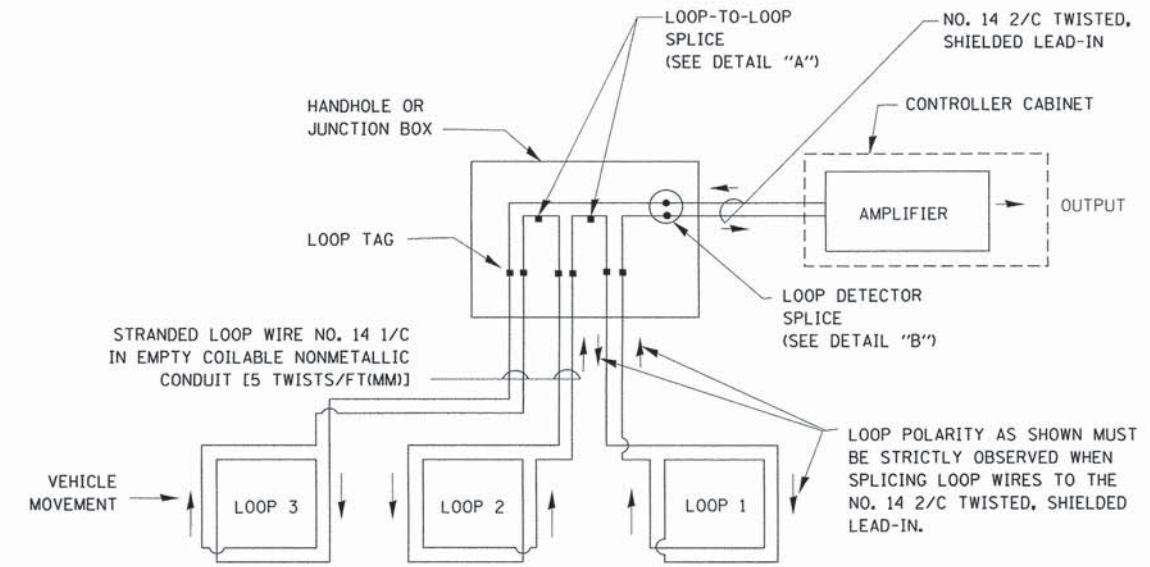

DETECTOR LOOP WIRING SCHEMATIC

- LOOPS SHALL BE SPLICED IN SERIES.
- SAW-CUTS SHALL BE A MINIMUM WIDTH OF 5/16" (8 mm).
- SAW-CUT DEPTHS SHALL BE 3" (75 mm). IF IN CONCRETE, THE SAW-CUT DEPTH SHALL BE TO THE TOP OF THE REINFORCEMENT.
- LOOP CORNERS SHALL BE DRILLED WITH A 2" (50 mm) DIAMETER CORE.

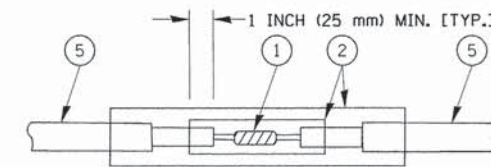

DETAIL "A"
LOOP-TO-LOOP SPLICE

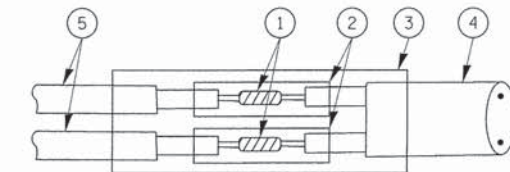

DETAIL "B"
LOOP-TO-CONTROLLER SPLICE

TYPE I LOOP

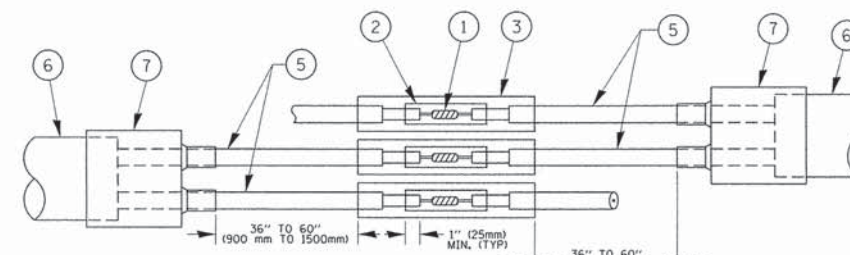

DETAIL "A"
LOOP-TO-LOOP SPLICE

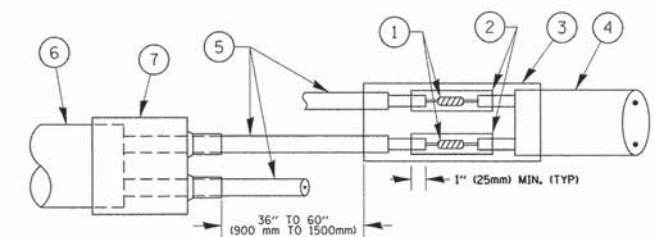

DETAIL "B"
LOOP-TO-CONTROLLER SPLICE

PREFORMED LOOP

LOOP DETECTOR SPLICE

- 1 WESTERN UNION SPLICE SOLDERED WITH ROSIN CORE FLUX. ALL EXPOSED SURFACES OF THE SOLDER SHALL BE SMOOTH. THE WESTERN UNION SPLICES SHALL BE STAGGERED.
- 2 WCSMW 30/100 HEAT SHRINK TUBE, MINIMUM LENGTH 3" (75 mm), UNDERWATER GRADE.
- 3 WCS 200/750 HEAT SHRINK TUBE, MINIMUM LENGTH 6" (150 mm), UNDERWATER GRADE.
- 4 NO. 14 2/C TWISTED, SHIELDED CABLE.
- 5 LOOP CONDUCTOR WITH FLEXIBLE PLASTIC TUBE.
- 6 PREFORMED LOOP
- 7 XL POLYOLEFIN 2 CONDUCTOR BREAKOUT SEALS. TYCO CBR-2 OR APPROVED EQUAL

LOOP LEAD-IN CABLE TAG

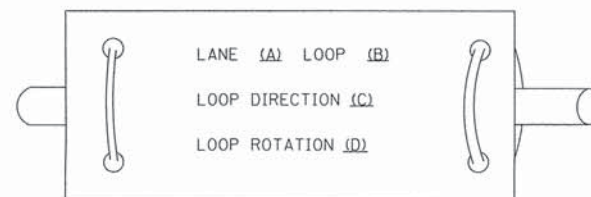

- A. LANE 1 IS THE LANE CLOSEST TO THE CENTERLINE OF THE ROADWAY
- B. LOOP #1 IS THE LOOP IN THE LANE CLOSEST TO THE INTERSECTION.
- C. LABEL LOOP CABLE "IN" OR LOOP CABLE "OUT".
- D. LABEL LOOP CABLE CLOCKWISE OR LOOP CABLE COUNTERCLOCKWISE.

FILE NAME =	USER NAME = footemj	DESIGNED - DAD	REVISED - DAG 1-1-14	STATE OF ILLINOIS DEPARTMENT OF TRANSPORTATION	DISTRICT ONE STANDARD TRAFFIC SIGNAL DESIGN DETAILS			F.A.P. RTE.	SECTION	COUNTY	TOTAL SHEETS	SHEET NO.
ca:\pw_work\pws\dos\footemj\d0108315\ts05.dgn		DRAWN - BCK	REVISED -		SCALE: NONE	SHEET NO. 2 OF 7 SHEETS	STA. TO STA.	870 & 347	13-00078-00-TL	DUPAGE	21	16
		CHECKED - DAD	REVISED -					TS-05		CONTRACT NO. 61A67		
		DATE - 10-28-09	REVISED -					FED. ROAD DIST. NO. 1 ILLINOIS FED. AID PROJECT				

**TRAFFIC SIGNAL MAST ARM AND SIGNAL POST
MAST ARM MOUNTED SIGNALS IN EXISTING, PROPOSED OR
FUTURE SIDEWALK/BICYCLE PATH AREA. INTERSECTION SHOWN
WITH PEDESTRIAN SIGNALS AND PEDESTRIAN PUSHBUTTON DETECTORS.**

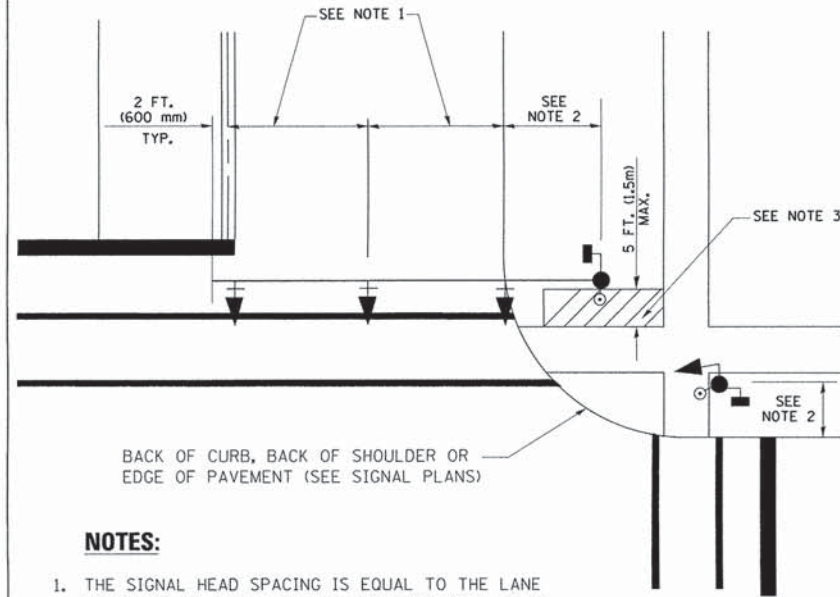

NOTES:

1. THE SIGNAL HEAD SPACING IS EQUAL TO THE LANE WIDTH OR AS SHOWN ON THE TRAFFIC SIGNAL PLAN.
2. REFER TO THE TRAFFIC SIGNAL EQUIPMENT OFFSET TABLE.
3. PROVIDE A LEVEL ALL-WEATHER SURFACE (CONCRETE SIDEWALK, ASPHALT BICYCLE PATH SURFACE OR MATCHING MATERIAL TO THE ADJACENT SURFACE) UP TO THE MAST ARM SHAFT OR THE SIGNAL POST.
4. THE FACE OF THE PEDESTRIAN PUSHBUTTON SHALL BE PARALLEL TO THE CROSSWALK TO BE USED.
5. THE LOCATIONS AND INSTALLATION OF PEDESTRIAN SIGNAL HEADS AND PEDESTRIAN PUSHBUTTONS SHALL MEET THE REQUIREMENTS OF THE MUTCD AND INFORMATION FOUND IN THE "AMERICANS WITH DISABILITIES ACT ACCESSIBILITY GUIDELINES FOR BUILDINGS AND FACILITIES."

**PEDESTRIAN SIGNAL POST
AND
PEDESTRIAN PUSH BUTTON POST**

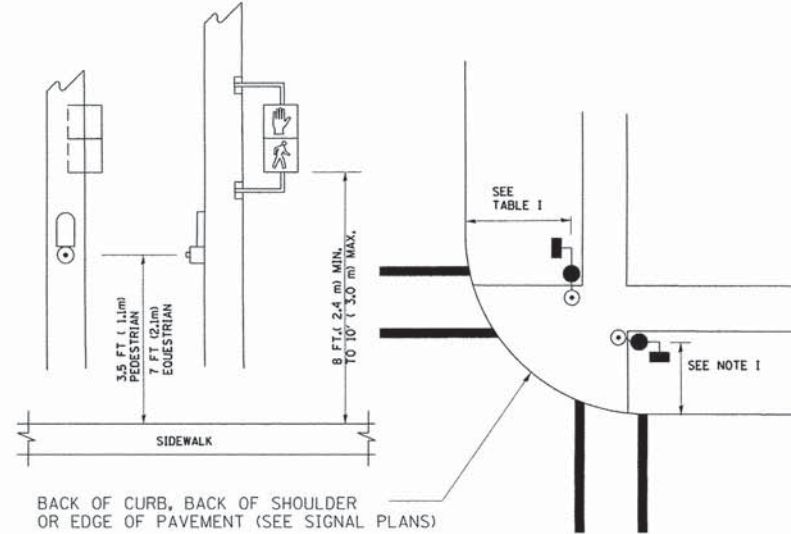

NOTES:

1. REFER TO THE TRAFFIC SIGNAL EQUIPMENT OFFSET TABLE.
2. PROVIDE A LEVEL ALL-WEATHER SURFACE (CONCRETE SIDEWALK, ASPHALT BICYCLE PATH SURFACE OR MATCHING MATERIAL TO THE ADJACENT SURFACE) UP TO THE PEDESTRIAN SIGNAL POST OR THE PEDESTRIAN PUSH BUTTON POST.
3. THE FACE OF THE PEDESTRIAN PUSHBUTTON SHALL BE PARALLEL TO THE CROSSWALK TO BE USED.
4. THE LOCATIONS AND INSTALLATION OF PEDESTRIAN SIGNAL HEADS AND PEDESTRIAN PUSHBUTTONS SHALL MEET THE REQUIREMENTS OF THE MUTCD AND INFORMATION FOUND IN THE "AMERICANS WITH DISABILITIES ACT ACCESSIBILITY GUIDELINES FOR BUILDINGS AND FACILITIES."

RECOMMENDED PUSHBUTTON LOCATIONS

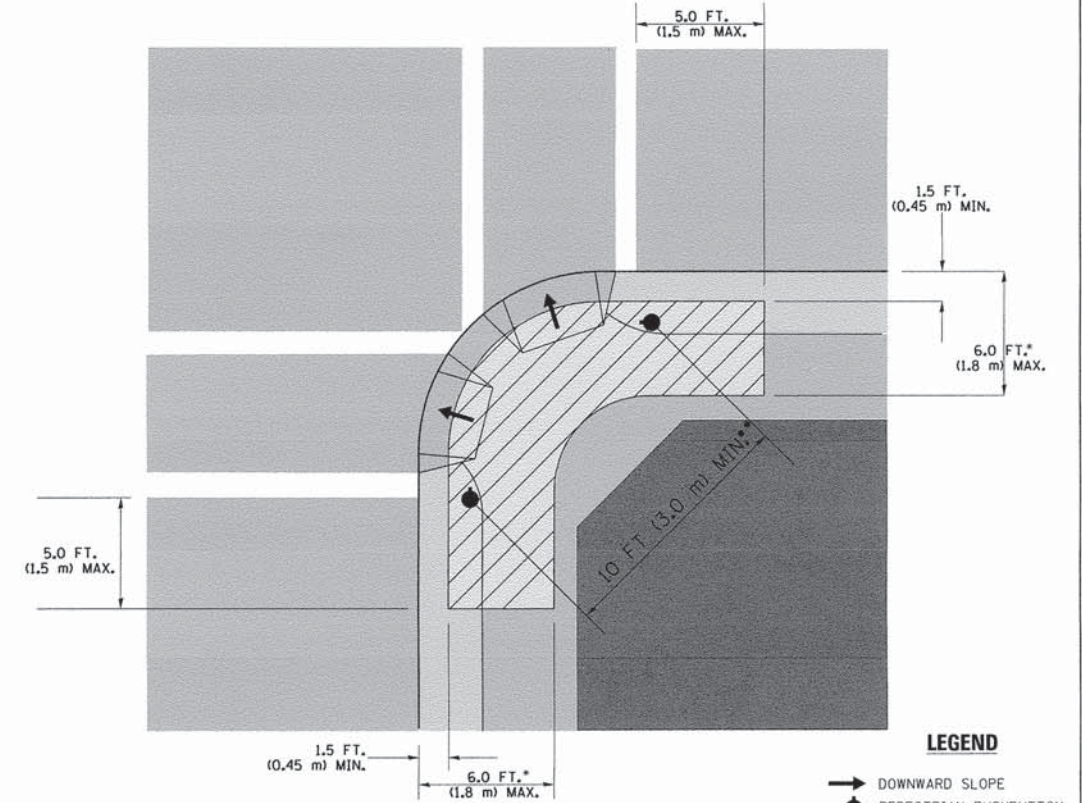

LEGEND

- DOWNWARD SLOPE
- PEDESTRIAN PUSHBUTTON
- ▨ RECOMMENDED PUSHBUTTON LOCATIONS

- WHERE THERE ARE CONSTRAINTS THAT MAKE IT IMPRACTICAL TO PLACE THE PEDESTRIAN PUSHBUTTON BETWEEN 1.5 FT (0.45 m) AND 6 FT (1.8 m) FROM THE EDGE OF THE CURB, SHOULDER, OR PAVEMENT, IT SHOULD NOT BE FURTHER THAN 10 FT (3 m) FROM THE EDGE OF CURB, SHOULDER, OR PAVEMENT.
- WHERE THERE ARE CONSTRAINTS ON A PARTICULAR CORNER THAT MAKE IT IMPRACTICAL TO PROVIDE THE 10 FT (3 m) SEPERATION BETWEEN THE TWO PEDESTRIAN PUSHBUTTONS, THE PUSHBUTTONS MAY BE PLACED CLOSER TOGETHER OR ON THE SAME POLE.

NOTES:

1. PEDESTRIAN SIGNAL HEADS SHALL BE MOUNTED WITH THE BOTTOM OF THE SIGNAL HOUSING INCLUDING BRACKETS NOT LESS THAN 8 FT (2.4 m) OR MORE THAN 10 FT (3 m) ABOVE SIDEWALK LEVEL, AND SHALL BE POSITIONED AND ADJUSTED TO PROVIDE MAXIMUM VISIBILITY AT THE BEGINNING OF THE CONTROLLED CROSSWALK.
2. THE BOTTOM OF THE SIGNAL HOUSING (INCLUDING BRACKETS) OF A VEHICULAR SIGNAL FACE THAT IS NOT LOCATED OVER A HIGHWAY SHALL BE AT LEAST 8 FT (2.4 m) BUT NOT MORE THAN 19 FT (5.8 m) ABOVE THE SIDEWALK OR, IF THERE IS NO SIDEWALK, ABOVE THE PAVEMENT GRADE AT THE CENTER OF THE ROADWAY.
3. THE BOTTOM OF THE SIGNAL HOUSING AND ANY RELATED ATTACHMENTS TO A SIGNAL FACE LOCATED OVER ANY PORTION OF A HIGHWAY SHALL BE ACCORDING TO CURRENT STATE STANDARDS 877001, 877002, 877006, 877011 AND 877012 WITH A MINIMUM OF 16 FT (5.0 m) AND A MAXIMUM OF 18 FT. (5.5 m) FROM THE HIGHEST POINT OF PAVEMENT.
4. THE BOTTOM OF THE TEMPORARY SPAN WIRE MOUNTED SIGNAL HOUSING AND ANY RELATED ATTACHMENTS TO A SIGNAL FACE LOCATED OVER ANY PORTION OF A HIGHWAY SHALL BE ACCORDING TO CURRENT STATE STANDARD 880001 WITH A MINIMUM OF 17 FT (5.18 m) FROM THE HIGHEST POINT OF PAVEMENT.
5. THE TOP OF THE SIGNAL HOUSING OF A SIGNAL FACE LOCATED OVER ANY PORTION OF A HIGHWAY SHALL NOT BE MORE THAN 25.6 FT (7.8 m) ABOVE THE PAVEMENT.

TRAFFIC SIGNAL EQUIPMENT OFFSET

TRAFFIC SIGNAL EQUIPMENT	COMBINATION CONCRETE CURB AND GUTTER (MINIMUM DISTANCE FROM BACK OF CURB TO CENTERLINE OF FOUNDATION)	SHOULDER/NON-CURBED AREA (MINIMUM DISTANCE FROM EDGE OF PAVEMENT TO CENTERLINE OF FOUNDATION)
TRAFFIC SIGNAL MAST ARM POLE	6 FT (1.8m)	SHOULDER WIDTH + 2 FT (0.6m), MINIMUM 10 FT (3.0m)
TRAFFIC SIGNAL POST	4 FT (1.2m)	SHOULDER WIDTH + 2 FT (0.6m), MINIMUM 10 FT (3.0m)
PEDESTRIAN SIGNAL POST	4 FT (1.2m)	SHOULDER WIDTH + 2 FT (0.6m), MINIMUM 10 FT (3.0m)
PEDESTRIAN PUSHBUTTON POST	4 FT (1.2m)	SHOULDER WIDTH + 2 FT (0.6m), MINIMUM 10 FT (3.0m)
TEMPORARY WOOD POLE	6 FT (1.8m)	SHOULDER WIDTH + 2 FT (0.6m), MINIMUM 10 FT (3.0m)
CONTROLLER CABINET	6 FT (1.8m) MINIMUM DISTANCE SEE NOTE 2	SHOULDER WIDTH + 6 FT (1.8m), MINIMUM 16 FT (4.9m) SEE NOTE 3.
SERVICE INSTALLATION, GROUND MOUNT	6 FT (1.8m) MINIMUM DISTANCE SEE NOTE 2	SHOULDER WIDTH + 6 FT (1.8m), MINIMUM 16 FT (4.9m) SEE NOTE 3.

NOTES:

1. CONTACT THE "AREA TRAFFIC SIGNAL MAINTENANCE AND OPERATIONS ENGINEER" FOR ASSISTANCE IN LOCATING THE TRAFFIC SIGNAL EQUIPMENT WHEN THERE ARE CONFLICTS WITH DITCHES OR THE MINIMUM OFFSET DISTANCES CANNOT BE MET.
2. MINIMUM DISTANCE FROM THE BACK OF CURB TO THE ROADWAY SIDE OF THE FOUNDATION.
3. MINIMUM DISTANCE FROM THE EDGE OF PAVEMENT TO THE ROADWAY SIDE OF THE FOUNDATION.
4. ANY CHANGES TO THE OFFSETS OF THE FOUNDATIONS, FROM THE MINIMUM DISTANCES LISTED IN THE "TRAFFIC SIGNAL EQUIPMENT OFFSET" CHART AND THE TRAFFIC SIGNAL INSTALLATION PLAN, COULD EFFECT THE PLACEMENT OF THE SIGNAL HEADS, PEDESTRIAN SIGNAL HEADS AND THE PEDESTRIAN PUSHBUTTONS. THE SIGNAL HEAD PLACEMENT ON THE MAST ARMS SHALL REMAIN AS PER THE TRAFFIC SIGNAL INSTALLATION PLAN AND THE "TRAFFIC SIGNAL MAST ARM AND SIGNAL POST" DETAIL ABOVE. THE PROPOSED MAST ARM LENGTHS MAY NEED TO BE REVISED TO MEET THE ABOVE REQUIREMENTS. THE PEDESTRIAN SIGNAL HEADS AND PEDESTRIAN PUSHBUTTONS MUST MEET THE REQUIREMENTS UNDER THE DETAILS ON THIS SHEET.

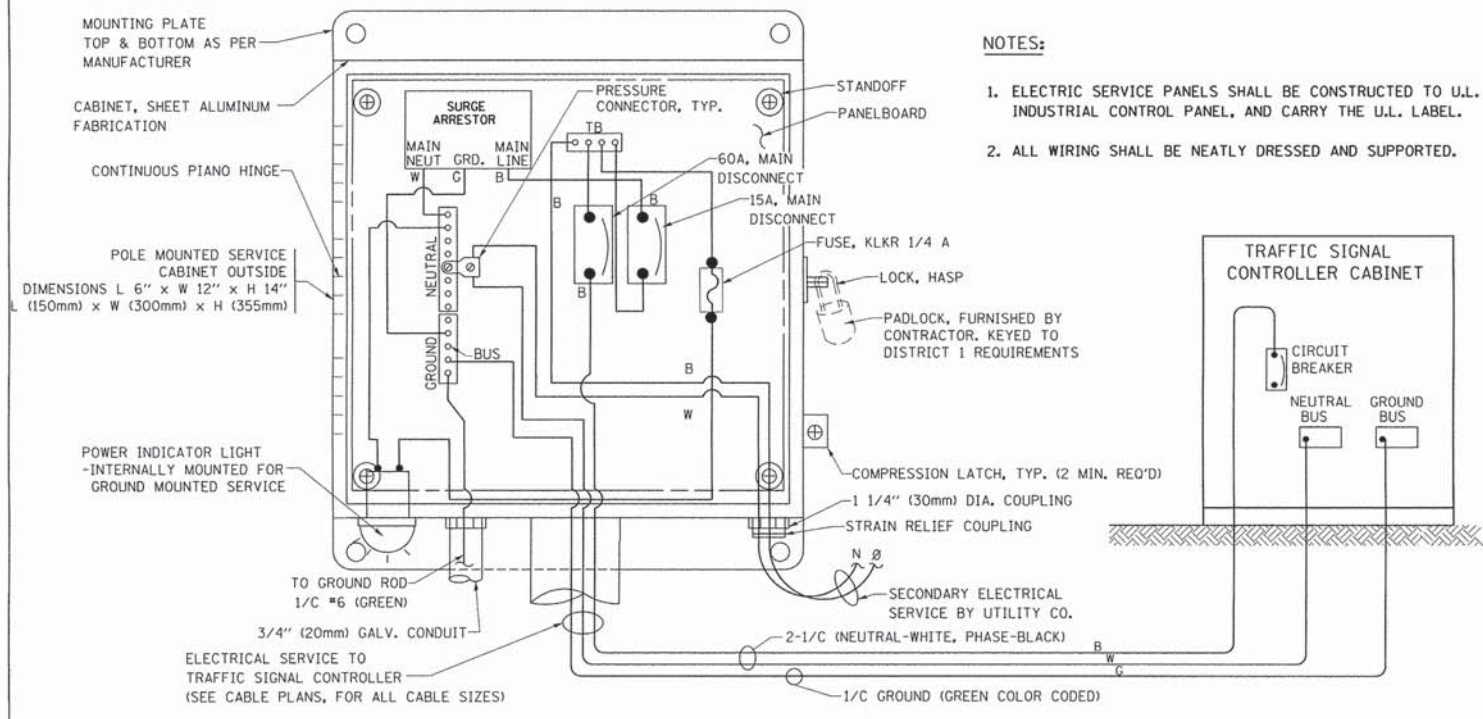

ELECTRICAL SERVICE - PANEL DIAGRAM (TYPICAL FOR POLE AND GROUND MOUNTED SERVICE)
SERVICE INSTALLATION POLE MOUNT (SHOWN)
 (NOT TO SCALE)

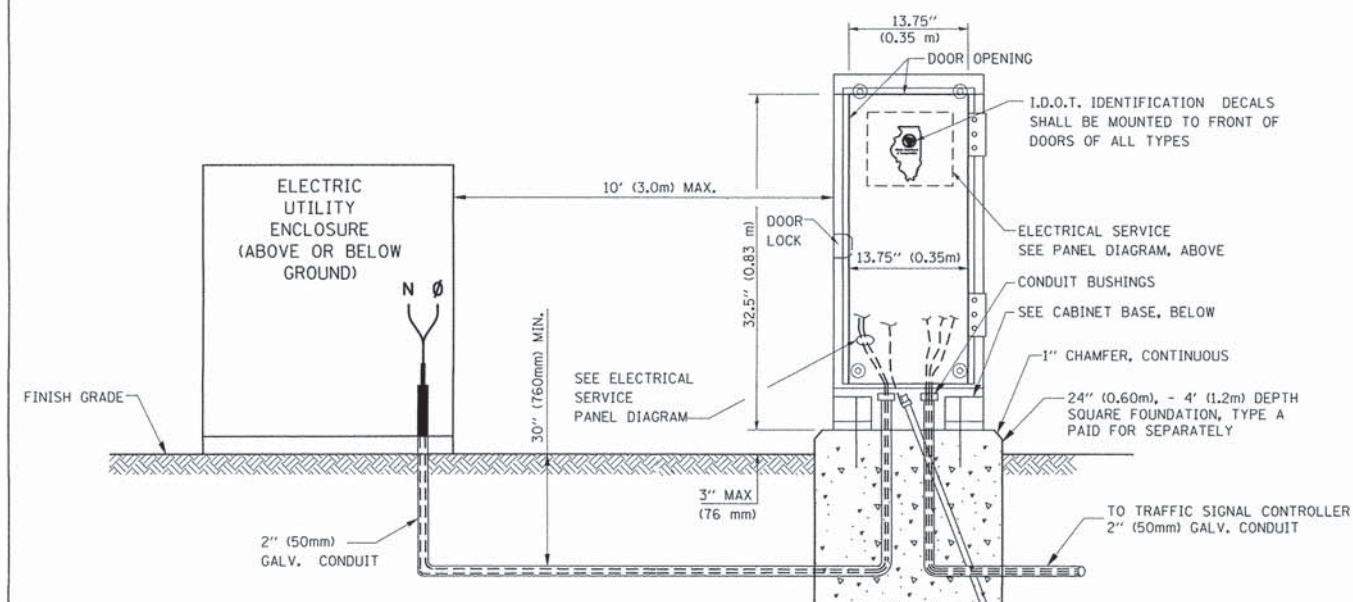

SERVICE INSTALLATION GROUND MOUNT
 (NOT TO SCALE)

CABINET - BASE BOLT PATTERN
 (NOT TO SCALE)

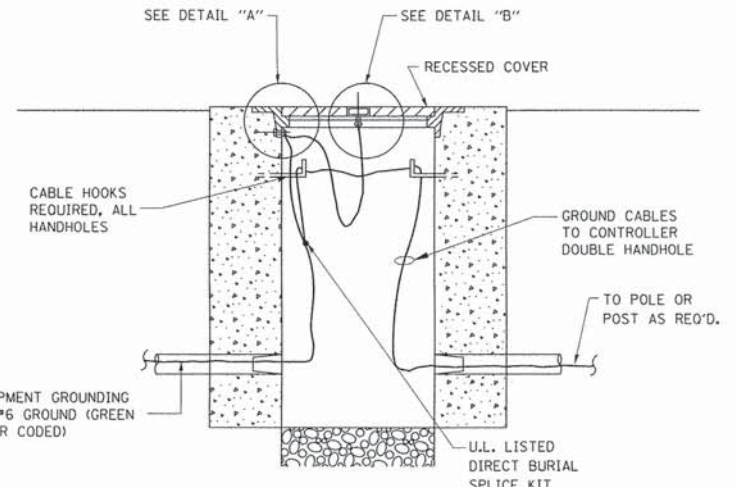
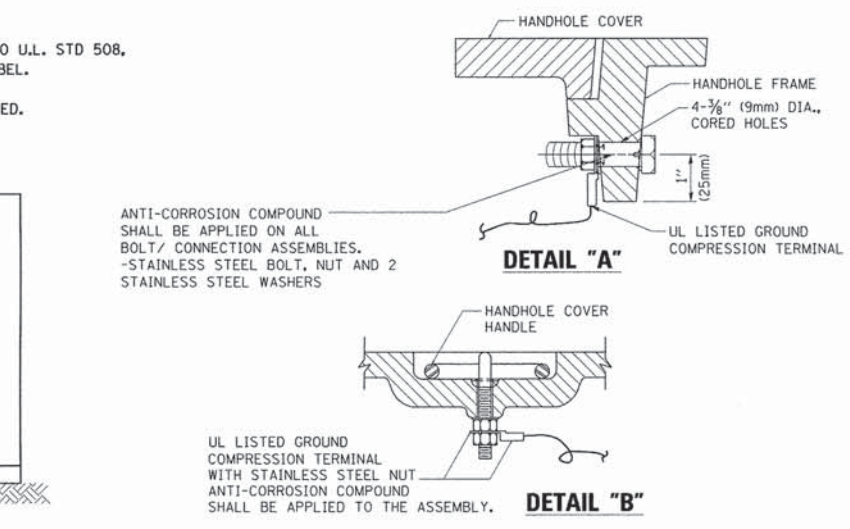
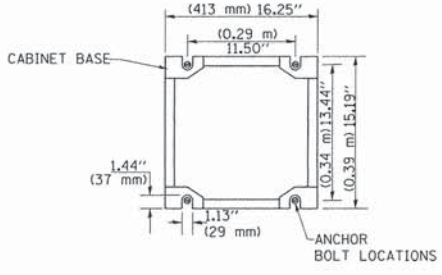

HANDHOLE COVER & FRAME - GROUNDING DETAIL
 (NOT TO SCALE)

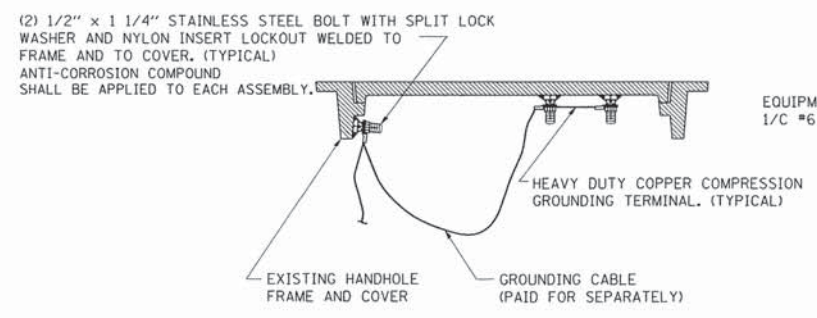

EXISTING HANDHOLE COVER & FRAME - GROUNDING DETAIL
 (NOT TO SCALE)

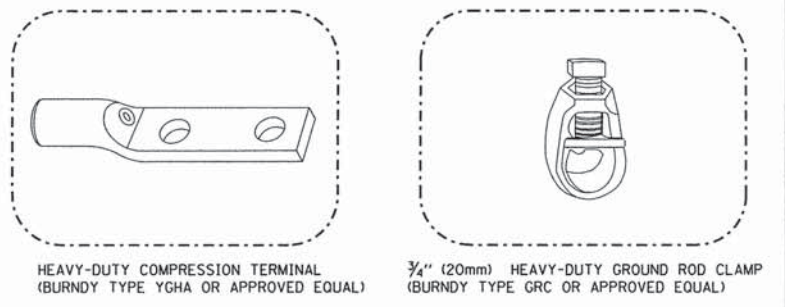

- NOTES:**
- ALL CLAMPS SHALL BE BRONZE OR COPPER, UL APPROVED.
 - GROUND CABLE SHALL BE LOOPED OVER HOOKS IN THE HANDHOLES
 - 6.5' (2.0m) SLACK SHALL BE PROVIDED IN SINGLE HANDHOLES
 - 13' (4.0m) OF SLACK SHALL BE PROVIDED IN DOUBLE HANDHOLES.
 - 5' (1.4m) OF SLACK SHALL BE PROVIDED BETWEEN FRAME AND COVER.

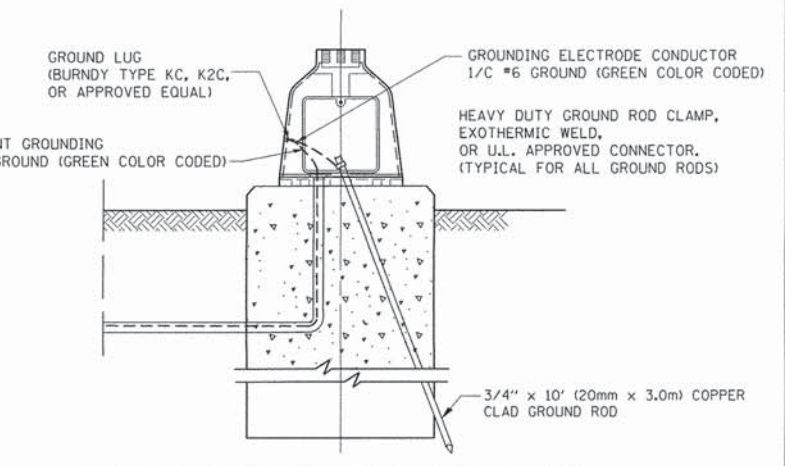

MAST ARM POLE / POST-GROUNDING DETAIL
 (NOT TO SCALE)

FILE NAME =	USER NAME = footemj	DESIGNED - DAD	REVISED - DAG 1-1-14
c:\pw\work\p4\dot\footemj\d0108315\ts05.dgn		DRAWN - BCK	REVISED -
PLOT SCALE = 50.0000' / 1" =		CHECKED - DAD	REVISED -
PLOT DATE = 1/13/2014		DATE - 10-28-09	REVISED -

STATE OF ILLINOIS
DEPARTMENT OF TRANSPORTATION

DISTRICT ONE		F.A.P. RTE. 870 & 347	SECTION 13-0078-00-TL	COUNTY DUPAGE	TOTAL SHEETS 21	SHEET NO. 18
STANDARD TRAFFIC SIGNAL DESIGN DETAILS		TS-05		CONTRACT NO. 61A67		
SCALE: NONE	SHEET NO. 4 OF 7 SHEETS	STA. TO STA.	FED. ROAD DIST. NO. 1 [ILLINOIS] FED. AID PROJECT			

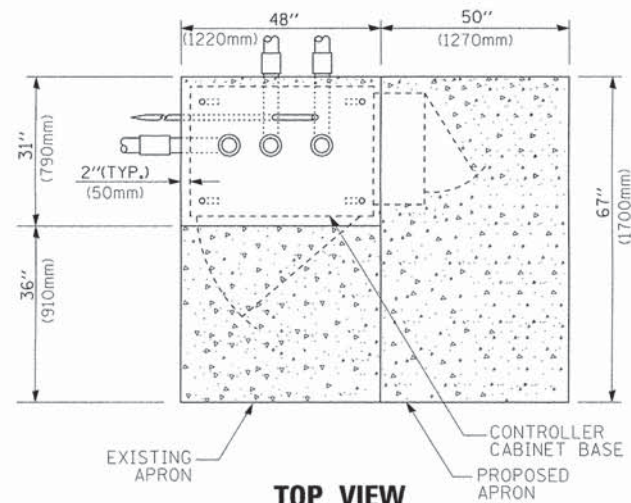

TOP VIEW

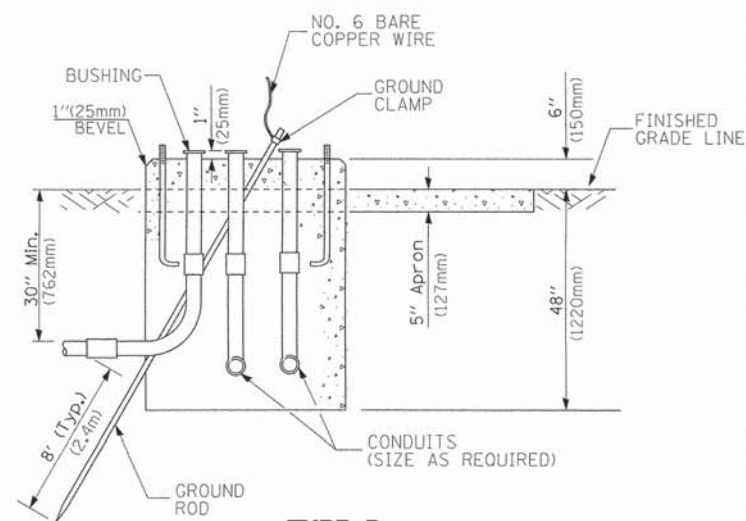

**TYPE D
FOR GROUND MOUNTED
CONTROLLER CABINET
AND UPS BATTERY CABINET**

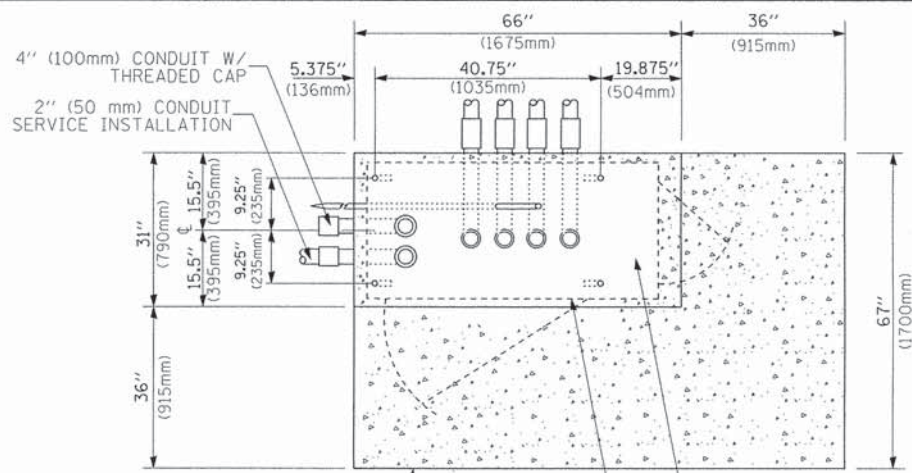

TOP VIEW

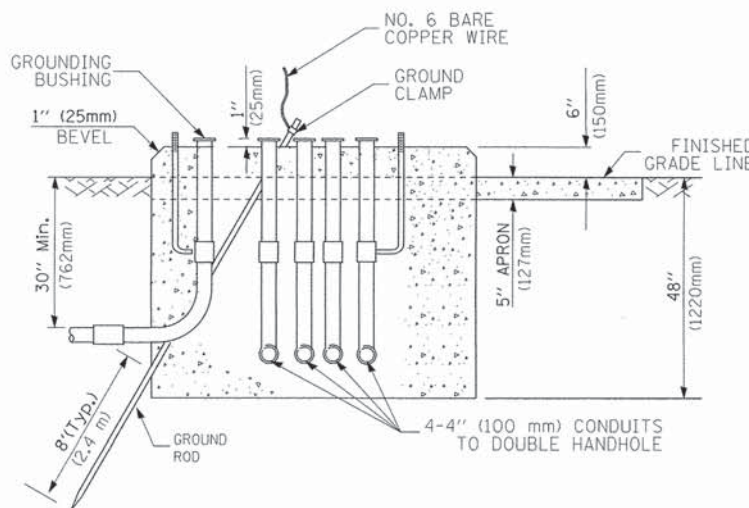

**TYPE C
FOR GROUND MOUNTED
SUPER P (TYPE IV) AND SUPER R (TYPE V)
CONTROLLER CABINETS**

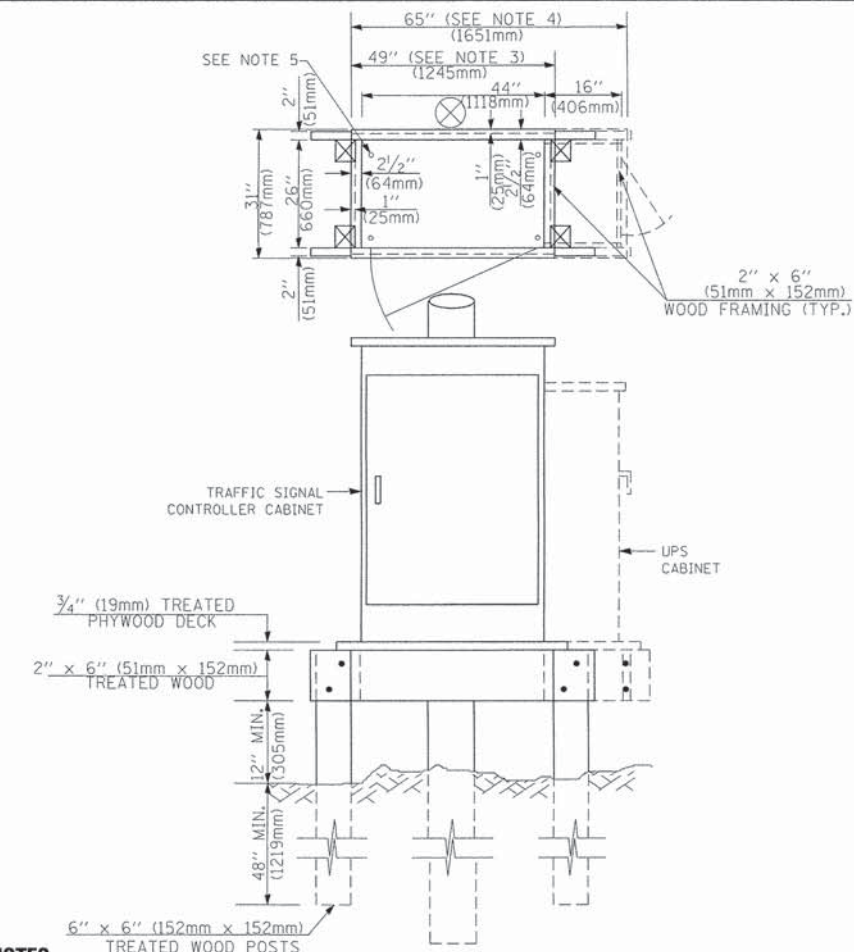

NOTES:

1. BASED ON CONTROLLER CABINET TYPE IV WITH BASE DIMENSIONS OF 26" x 44" (660mm x 1118mm). ADJUST PLATFORM SIZE TO FIT CABINET BASE DIMENSIONS BEING SUPPLIED.
2. BASED ON UNINTERRUPTIBLE POWER SUPPLY CABINET WITH BASE DIMENSIONS OF 16" x 25" (406mm x 635mm). ADJUST PLATFORM SIZE TO FIT CABINET BASE DIMENSIONS BEING SUPPLIED.
3. PLATFORM SIZE FOR CONTROLLER CABINET TYPE IV.
4. PLATFORM SIZE FOR CONTROLLER CABINET TYPE IV AND UNINTERRUPTIBLE POWER SUPPLY CABINET.
5. DRILLED HOLES THROUGH THE PLATFORM BASE TO MATCH THE CONTROLLER CABINET BOLT TEMPLATE. FASTEN THE CONTROLLER CABINET TO THE PLATFORM WITH CARRIAGE BOLTS, WASHERS AND NUTS.
6. FASTEN ALL SUPPORT WOOD FRAMING TO THE WOOD POSTS WITH 2 LAG SCREWS FOR EACH CONNECTION.

**TEMPORARY SIGNAL CONTROLLER
WOOD SUPPORT PLATFORM**

CABLE SLACK LENGTH	FEET	METER
HANDHOLE	6.5	2.0
DOUBLE HANDHOLE	13.0	4.0
SIGNAL POST	2.0	0.6
MAST ARM	2.0	0.6
CONTROLLER CABINET	1.5	0.5
FIBER OPTIC AT CABINET	13.0	4.0
ELECTRIC SERVICE AT (CABINET OR SERVICE LOCATION)	1.5	0.5
GROUND CABLE (SIGNAL POST, MAST ARM, CABINET)	1.5	0.5
GROUND CABLE (BETWEEN FRAME AND COVER)	5.0	1.6

CABLE SLACK

VERTICAL CABLE LENGTH	FEET	METER
MAST ARM POLE (MAST ARM MOUNTED SIGNAL HEAD) (L = MAST ARM LENGTH - DISTANCE TO SIGNAL HEAD FROM END OF ARM)	20.0+L	6.0+L
BRACKET MOUNTED (MAST ARM POLE OR SIGNAL POLE)	13.0	4.0
PEDESTRIAN PUSH BUTTON	6.0	2.0
SERVICE INSTALLATION POLE MOUNT TO SERVICE DROP	13.5	4.1
SERVICE INSTALLATION POLE MOUNT TO GROUND	13.5	4.1
SERVICE INSTALLATION GROUND MOUNT	6.0	2.0
FOUNDATION (SIGNAL POST, MAST ARM POLE, CONTROLLER CABINET, SERVICE-GROUND MOUNT)	3.0	1.0

VERTICAL CABLE LENGTH

FOUNDATION	DEPTH
TYPE A - Signal Post	4'-0" (1.2m)
TYPE C - CONTROLLER W/ UPS	4'-0" (1.2m)
TYPE D - CONTROLLER	4'-0" (1.2m)
SERVICE INSTALLATION, GROUND MOUNT, TYPE A - SQUARE	4'-0" (1.2m)

DEPTH OF FOUNDATION

Mast Arm Length	① Foundation Depth	Foundation Diameter	Spiral Diameter	Quantity of Rebars	Size of Rebars
Less than 30' (9.1 m)	10'-0" (3.0 m)	30" (750mm)	24" (600mm)	8	6(19)
Greater than or equal to 30' (9.1 m) and less than 40' (12.2 m)	13'-6" (4.1 m)	30" (750mm)	24" (600mm)	8	6(19)
	11'-0" (3.4 m)	36" (900mm)	30" (750mm)	12	7(22)
Greater than or equal to 40' (12.2 m) and less than 50' (15.2 m)	13'-0" (4.0 m)	36" (900mm)	30" (750mm)	12	7(22)
	15'-0" (4.6 m)	36" (900mm)	30" (750mm)	12	7(22)
Greater than or equal to 50' (15.2 m) and up to 55' (16.8 m)	21'-0" (6.4 m)	42" (1060mm)	36" (900mm)	16	8(25)
	25'-0" (7.6 m)	42" (1060mm)	36" (900mm)	16	8(25)

NOTES:

1. These foundation depths are for sites which have cohesive soils (clayey silt, sandy clay, etc.) along the length of the shaft, with an average Unconfined Compressive Strength (Q_u) > 1.0 tsf (100 kpa). This strength shall be verified by boring data prior to construction or with testing by the Engineer during foundation drilling. The Bureau of Bridges & Structures should be contacted for a revised design if other conditions are encountered.
2. Combination mast arm assemblies under 55 feet (16.8 m) shall use 36" (900 mm) diameter foundations.
3. Combination mast arm assemblies under 56 feet (16.8 m) through 75 feet (22.9 m) shall use 42" (1060 mm) diameter foundations.
4. For mast arm assemblies with dual arms refer to state standard 878001.

DEPTH OF MAST ARM FOUNDATIONS, TYPE E

FILE NAME =	USER NAME = foatemj	DESIGNED - DAG	REVISED - DAG 1-1-14
ct\pw_work\p\dot\foatemj\0108315\ts05.dgn		DRAWN - BCK	REVISED -
PLOT SCALE = 50.0000' / in.		CHECKED - DAD	REVISED -
PLOT DATE = 1/13/2014		DATE - 10-28-09	REVISED -

**STATE OF ILLINOIS
DEPARTMENT OF TRANSPORTATION**

DISTRICT ONE		F.A.P. RTE. 870 & 347	SECTION 13-00078-00-TL	COUNTY DUPAGE	TOTAL SHEETS 21	SHEET NO. 19
STANDARD TRAFFIC SIGNAL DESIGN DETAILS		TS-05		CONTRACT NO. 61A67		
SCALE: NONE	SHEET NO. 5 OF 7 SHEETS	STA. TO STA.	FED. ROAD DIST. NO. 1 ILLINOIS FED. AID PROJECT			

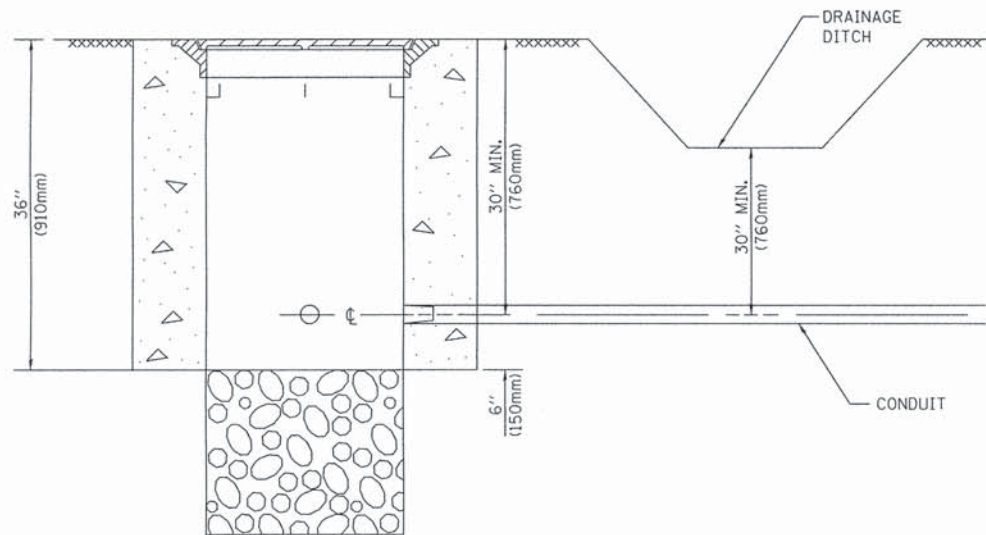

NOTES:

1. CONDUIT DEPTH SHALL BE A MINIMUM OF 30" (760mm) BELOW THE BOTTOM OF THE DRAINAGE DITCH OR ANY SLOPING GROUND
2. THE MINIMUM CONDUIT DEPTH APPLIES TO ALL CONDUIT PLACED UNDER ROADWAY PAVEMENT, MULTI-USE PATHS, SIDEWALKS AND SOIL SURFACES.
3. THE MINIMUM CONDUIT DEPTH APPLIES TO ALL HANDHOLES, HEAVY DUTY HANDHOLES AND DOUBLE HANDHOLES.

HANDHOLE WITH MINIMUM CONDUIT DEPTH
(NOT TO SCALE)

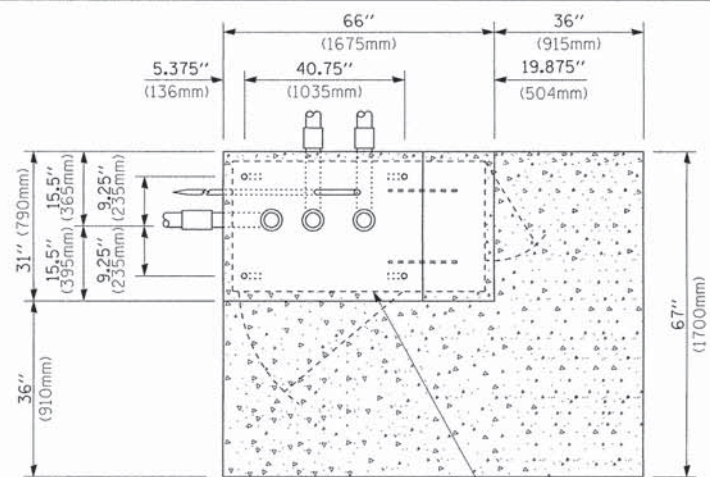

TOP VIEW
(NOT TO SCALE)

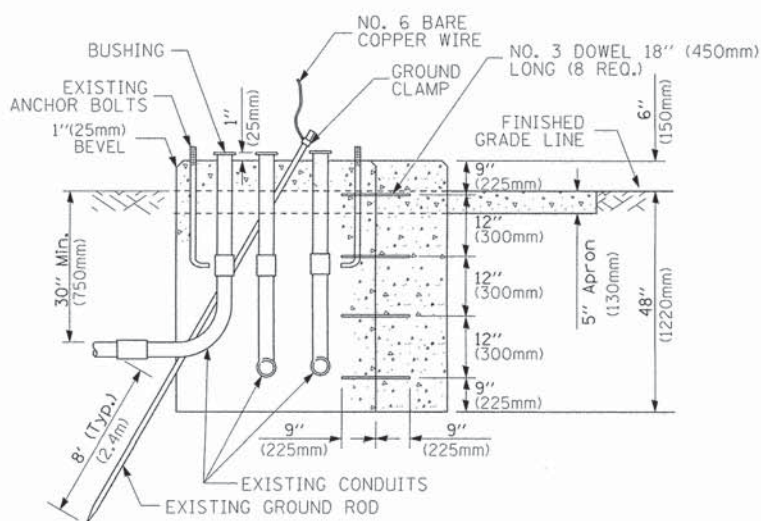

MODIFY EXISTING TYPE "D" FOUNDATION TO TYPE "C" FOUNDATION
(NOT TO SCALE)

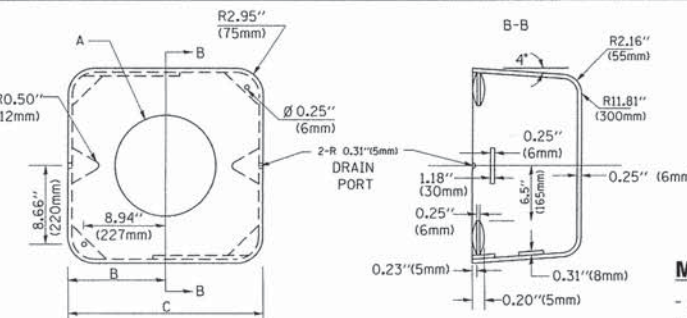

MATERIAL:
- ASTM A36 STEEL
- ASTM A-123 HOT DIPPED GALVANIZED

	A	B	C	HEIGHT	WEIGHT
VARIES	9.5" (241mm)	19" (483mm)	19" (483mm)	7" (178mm) - 12" (300mm)	53 lbs (24kg)
VARIES	10.75" (273mm)	21.5" (546mm)	21.5" (546mm)	7" (178mm) - 12" (300mm)	68 lbs (31 kg)
VARIES	13.0" (330mm)	26" (660mm)	26" (660mm)	7" (178mm) - 12" (300mm)	81 lbs (37 kg)
VARIES	18.5" (470mm)	37" (940mm)	37" (940mm)	7" (178mm) - 12" (300mm)	126 lbs (57 kg)

SHROUD

NOTES:

1. DIMENSION "A" IS EQUAL TO THE DIAMETER OF THE MAST ARM POLE AT THE TOP OF THE SHROUD. THE SHROUD SHALL BE TIGHT TO THE MAST ARM POLE.
2. THE SUPPLIER SHALL VERIFY THE ABOVE DIMENSIONS BASED ON MAST ARM REQUIREMENTS.
3. THE HEIGHT OF THE SHROUD SHALL COVER THE ANCHOR BOLTS, NUTS AND MAST ARM POLE BASE.

NOTE:

SUPPORT EXISTING CABINET AND CONTROL EQUIPMENT ABOVE FOUNDATION TO KEEP TRAFFIC SIGNAL FUNCTIONING WHILE FOUNDATION MODIFICATION WORK IS PROCEEDING.

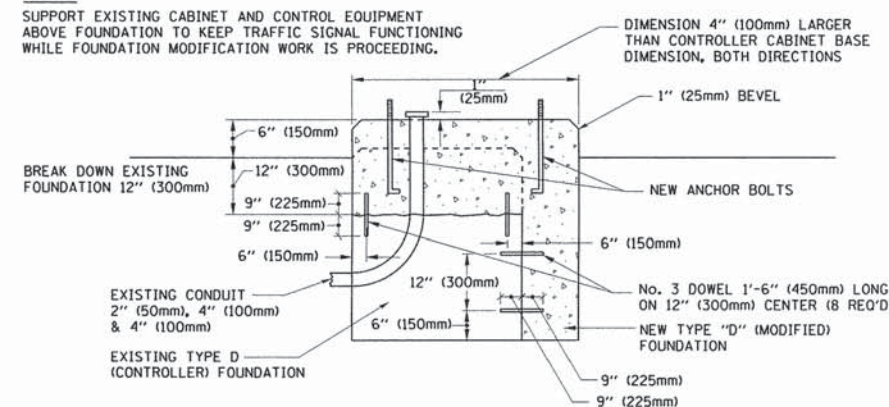

MODIFY EXISTING TYPE "D" FOUNDATION

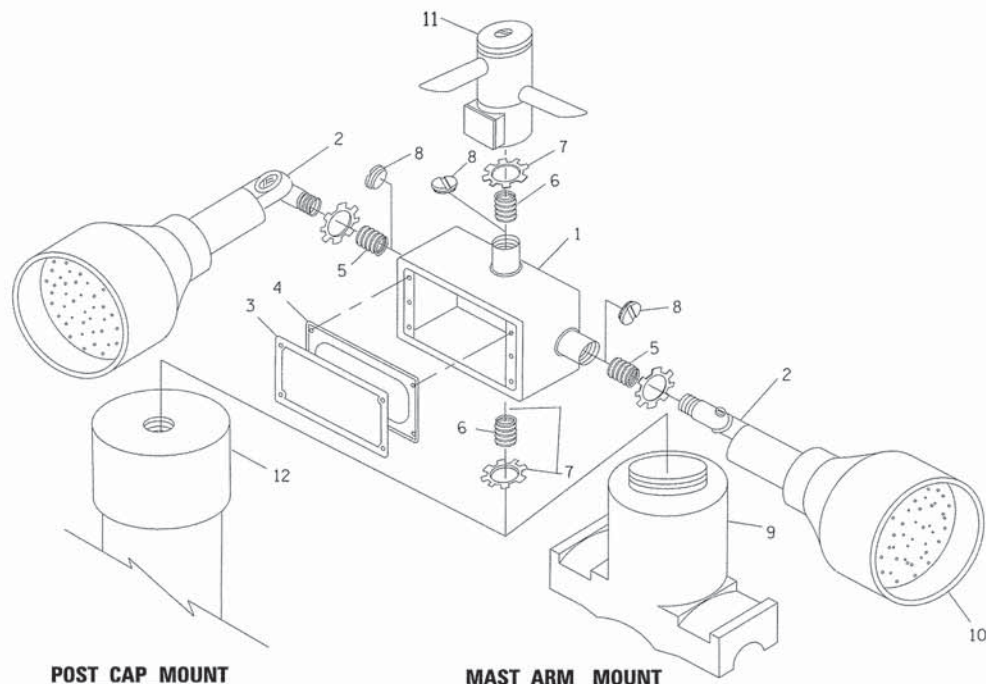

ITEM NO.	IDENTIFICATION
1	OUTLET BOX- GALV. 21 CU. IN. (0.000344 CU-M)
2	LAMP HOLDER AND COVER
3	OUTLET BOX COVER
4	RUBBER COVER GASKET
5	REDUCING BUSHING
6	3/4" (19 mm) CLOSE NIPPLE
7	3/4" (19 mm) LOCKNUT
8	3/4" (19 mm) HOLE PLUG
9	SADDLE BRACKET - GALV.
10	6 WATT PAR 38 LED FLOOD LAMP
11	DETECTOR UNIT
12	POST CAP [18 FT. (5.4 m) POST MIN.]

NOTES:

1. ALL ELECTRICAL ITEMS, EXCEPT ITEMS #2 AND #11 SHALL BE ALUMINUM OR GALVANIZED
2. ITEM #1- OZ/GEDNEY FSX-1-50 OR EQUIVALENT
ITEM #2- MULBERRY CON-O-SHADE LAMP SHIELD OR EQUIVALENT
ITEM #9- "BAND-IT" SADDLE BRACKET OR EQUIVALENT
3. WHEN POST MOUNTING IS SPECIFIED, ITEM #9 SHALL NOT BE REQUIRED. THE DETECTION UNIT SHALL BE MOUNTED DIRECTLY ON TOP OF THE CAP BY DRILLING AND TAPPING A 3/4" (19 mm) HOLE WITH PIPE THREADS. THE POST CAP SHALL EITHER BE SCREWED TO THE TOP OF THE POST OR A MINIMUM OF 3 TIGHTENING SCREWS SHALL BE REQUIRED ON EACH CAP.

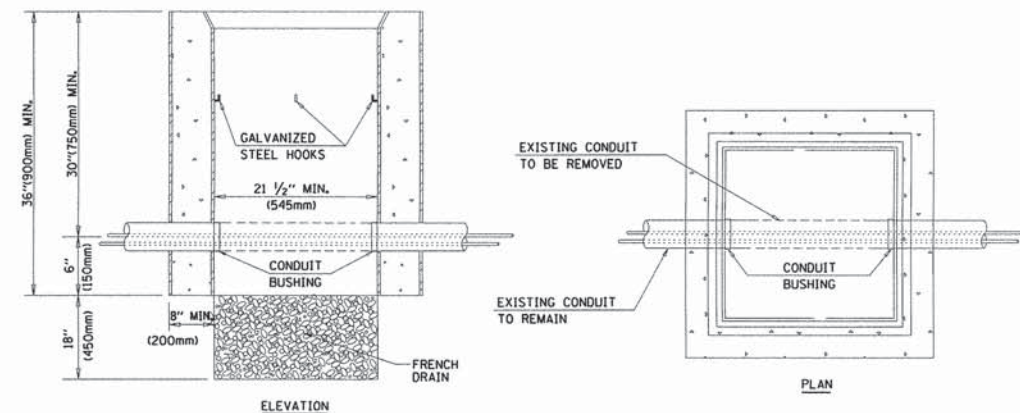

NOTES:

1. HANDHOLE CONSTRUCTED PER STATE STANDARD 814001.
2. REMOVAL OF THE EXISTING CONDUIT FROM THE HANDHOLE AND THE INSTALLATION OF THE CONDUIT BUSHINGS SHALL BE INCLUDED WITH THE COST OF THE HANDHOLE.

HANDHOLE TO INTERCEPT EXISTING CONDUIT

FILE NAME =	USER NAME = footemj	DESIGNED - DAD	REVISED - DAG 1-1-14
ci:\pw_work\pwr\d01\footemj\d0100315\ts05.dgn		DRAWN - BCK	REVISED -
PLOT SCALE = 50.0000' / 1"		CHECKED - DAD	REVISED -
PLOT DATE = 1/13/2014		DATE - 10-28-09	REVISED -

STATE OF ILLINOIS
DEPARTMENT OF TRANSPORTATION

DISTRICT ONE
STANDARD TRAFFIC SIGNAL DESIGN DETAILS

F.A.P. RTE. 870 & 347	SECTION 13-00078-00-TL	COUNTY DUPAGE	TOTAL SHEETS 21	SHEET NO. 20
TS-05		CONTRACT NO. 61A67		
FED. ROAD DIST. NO. 1 [ILLINOIS] FED. AID PROJECT				

SCALE: NONE SHEET NO. 6 OF 7 SHEETS STA. TO STA.

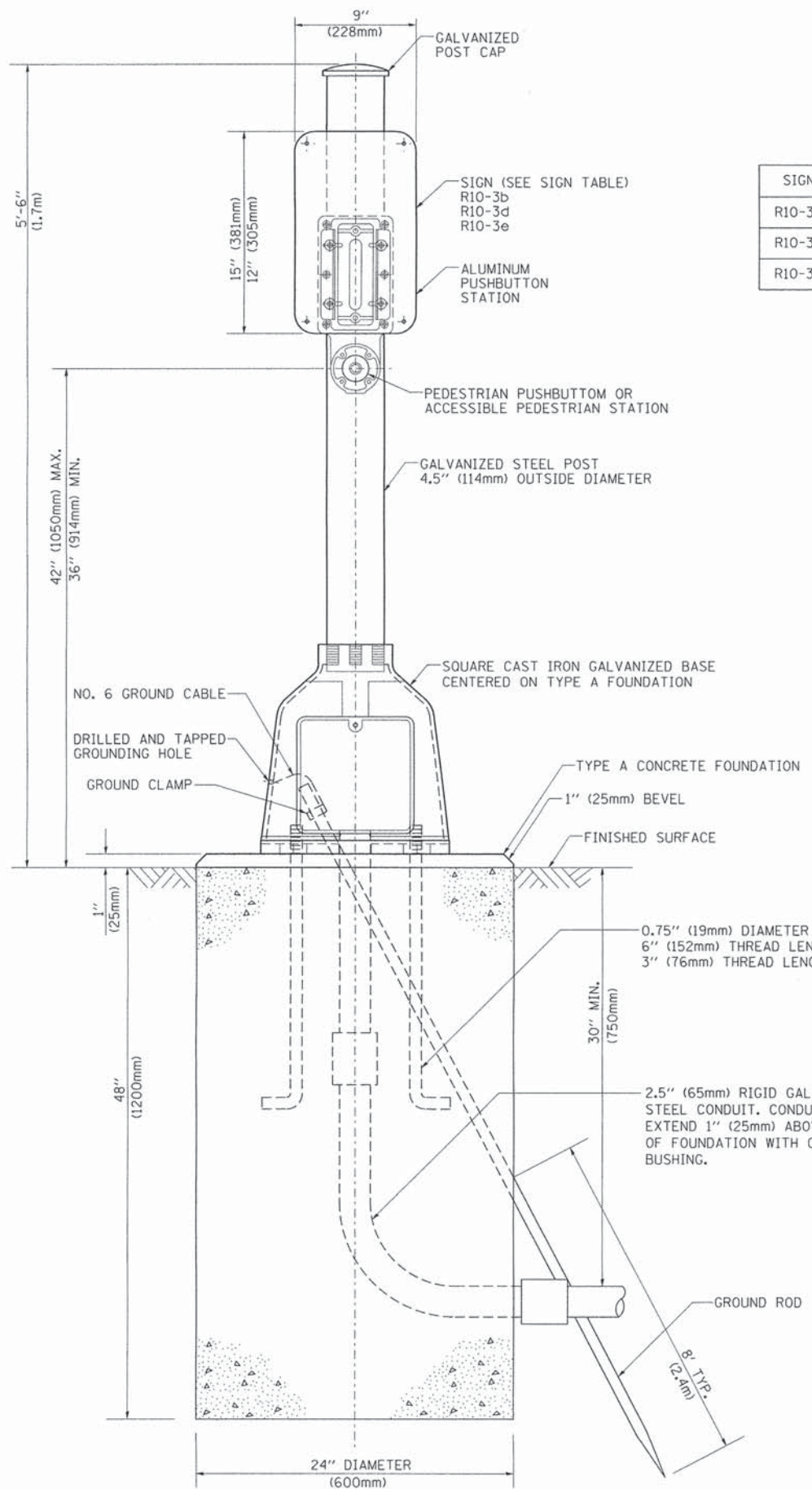

SIGN TABLE

SIGN	DIMENSIONS
R10-3b	9" (228mm) X 12" (305mm)
R10-3d	9" (228mm) X 12" (305mm)
R10-3e	9" (228mm) X 15" (381mm)

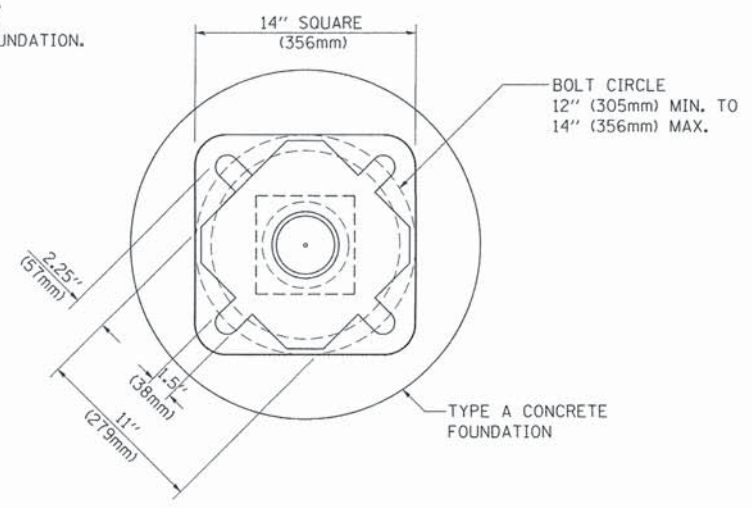

BOLT PATTERN
PEDESTRIAN PUSH BUTTON POST, TYPE A

FILE NAME =	USER NAME = footemj	DESIGNED - DAG	REVISED - DAG 1-1-14
cs:\pw_work\pwsdot\footemj\d8108315\ts05.dgn		DRAWN - GND	REVISED -
PLOT SCALE = 50.0000' / 1"		CHECKED - DAD	REVISED -
PLOT DATE = 1/13/2014		DATE - 10/1/2012	REVISED -

STATE OF ILLINOIS
DEPARTMENT OF TRANSPORTATION

DISTRICT ONE
STANDARD TRAFFIC SIGNAL DESIGN DETAILS
SCALE: NONE SHEET NO. 7 OF 7 SHEETS STA. TO STA.

F.A.P. RTE. 870 & 347	SECTION 13-00078-00-TL	COUNTY DUPAGE	TOTAL SHEETS 21	SHEET NO. 21
TS-05		CONTRACT NO. 61A67		
FED. ROAD DIST. NO. 1 ILLINOIS FED. AID PROJECT				