

CENTER LANE CLOSURE

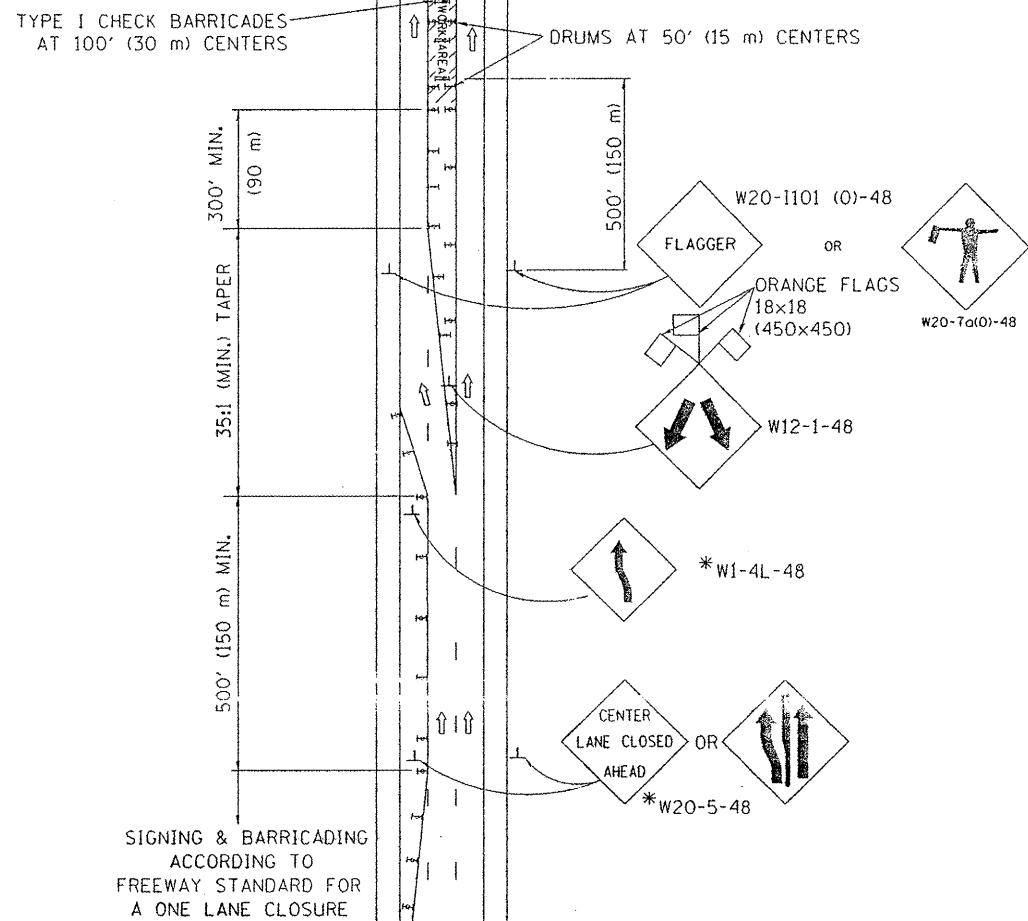

1. DAY OPERATIONS: CONES SHALL BE USED AT 25' (8 m) CENTERS ON TAPERS AND AT 50' (15 m) CENTERS ON TANGENTS.
2. NIGHT OPERATIONS: DRUMS WITH STEADY BURN LIGHTS SHALL BE USED AT 50' (15 m) CENTERS ON ALL TAPERS AND TANGENTS IN ADVANCE OF WORK AREA.
3. CLOSURE SHALL BE USED ONLY FOR OPERATIONS LASTING 72 HOURS OR LESS.

INSTALLATION SEQUENCE

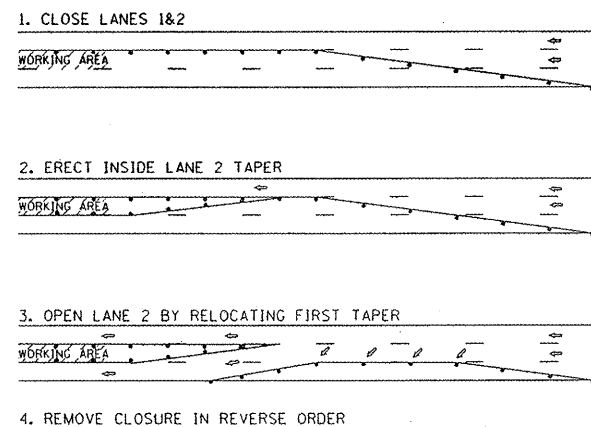

SHOULDER LANE

NOTE: CLOSURE SHALL BE USED ONLY FOR OPERATIONS LASTING 72 HOURS OR LESS.

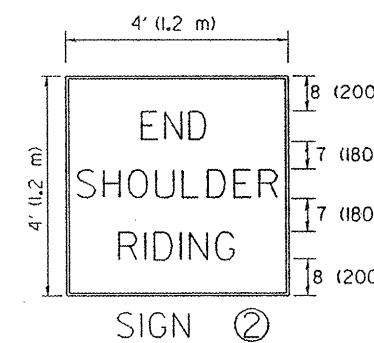
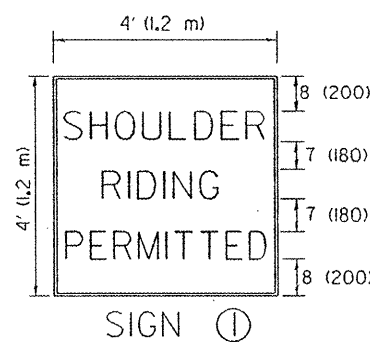
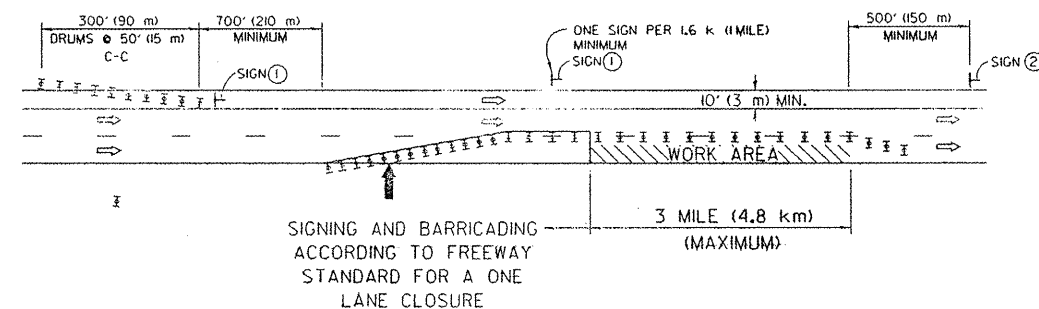
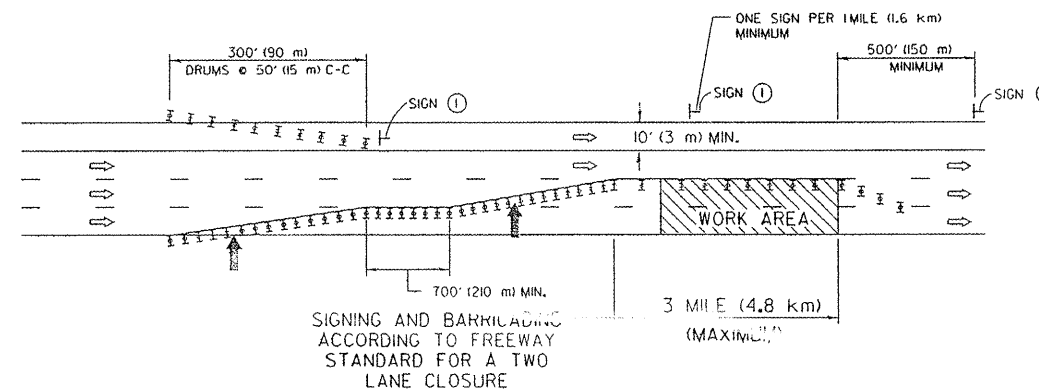

6 (150) SERIES "C" LEGEND
BLACK LEGEND
WHITE REFLECT. BACKGROUND
1(25) BORDER

SYMBOLS

- ↑ DIRECTION OF TRAFFIC
- ➡ ARROWBOARD
- ▨ WORK AREA
- ◇ SIGN WITH 18x18 (450x450) ORANGE FLAGS ATTACHED *
- ┌ SIGN ON PORTABLE OR PERMANENT SUPPORT *
- ⊥ TYPE II BARRICADE, DRUM OR VERTICAL BARRICADE WITH MONO-DIRECTIONAL STEADY BURN LIGHT

ALL DIMENSIONS ARE IN INCHES (MILLIMETERS) UNLESS OTHERWISE SHOWN

* ALL SIGNS SHALL BE MOUNTED AT A MINIMUM HEIGHT OF 5' (1.5 m).

| | | | |
|---|------------------------|------------|------------------------|
| FILE NAME = W:\distrs\td\22\34\1\c25.dgn | USER NAME = goglianob1 | DESIGNED - | REVISED - J.A.F. 04-03 |
| | | DRAWN - | REVISED - S.P.B. 01-07 |
| | | CHECKED - | REVISED - |
| | | DATE - | REVISED - |
| | | | |

STATE OF ILLINOIS
DEPARTMENT OF TRANSPORTATION

TRAFFIC CONTROL DETAILS FOR FREEWAY
CENTER LANE CLOSURE SHOULDER LANE

SCALE: NONE SHEET NO. 1 OF 1 SHEETS STA. TO STA.

| | | | | |
|---|---------|--------|--------------------|-----------|
| F.A. RTE. | SECTION | COUNTY | TOTAL SHEETS | SHEET NO. |
| | TC-25 | | 69 | 69 |
| FED. ROAD DIST. NO. 1 ILLINOIS FED. AID PROJECT | | | CONTRACT NO. 60F04 | |