

**NEW CONSTRUCTION**

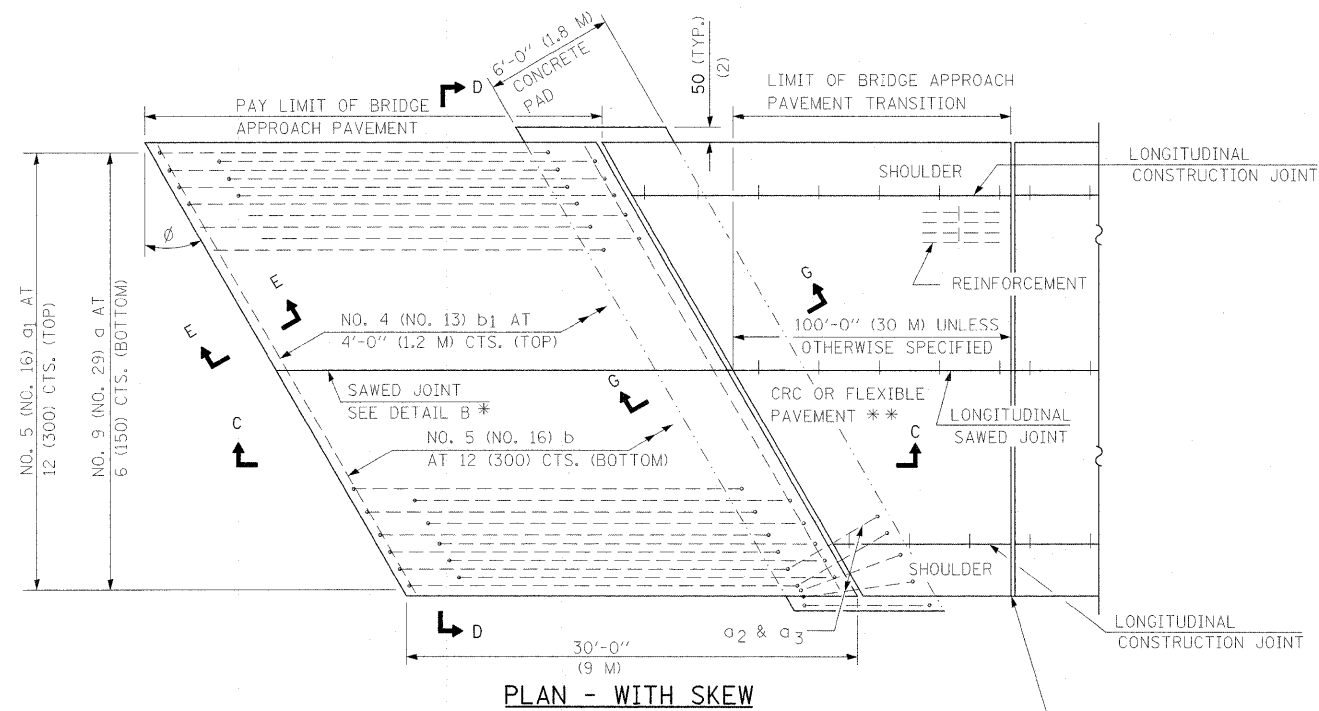

**PLAN - WITH SKEW**

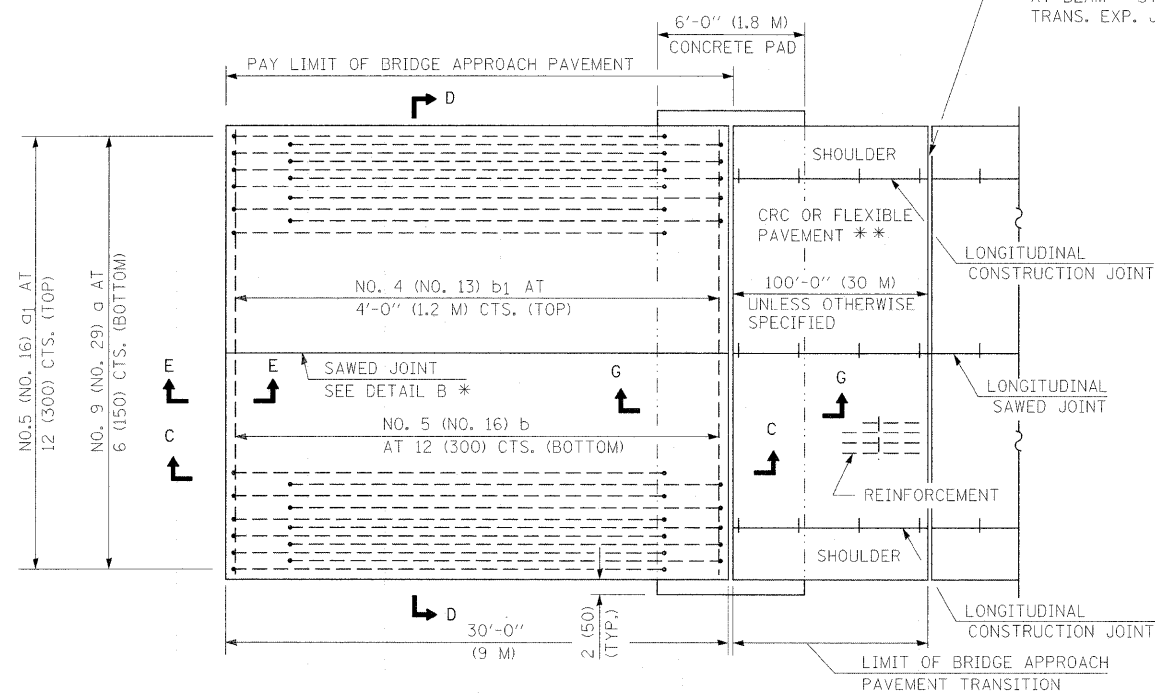

**PLAN - WITHOUT SKEW**

\* SAW  $\phi$  OR LANE EDGE IF POURED TWO OR MORE LANE WIDTHS AT A TIME.  
 \*\* OMIT REINFORCEMENT, TIE BARS AND LONG. SAWED JT. FOR FLEXIBLE PAVEMENT.

RIGID PAVEMENT ONLY:  
 WIDE FLANGE BEAM TERMINAL JOINT (SEE DETAIL AT BEAM - STANDARD 421101 OR 421106) OR 2 (50) TRANS. EXP. JOINT AS DETAILED ON STANDARD 420001.

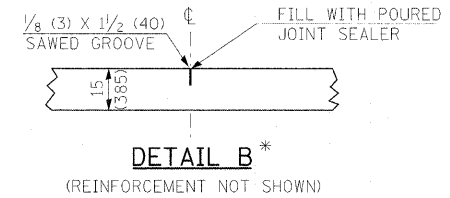

**DETAIL B\***

(REINFORCEMENT NOT SHOWN)

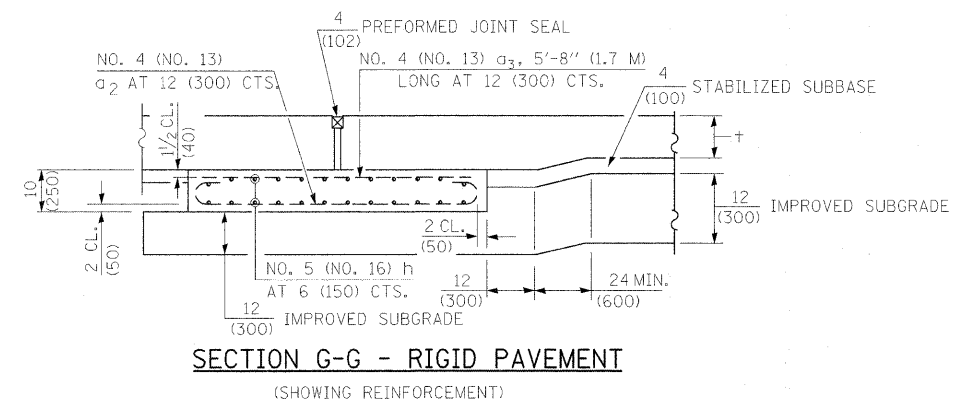

**SECTION G-G - RIGID PAVEMENT**

(SHOWING REINFORCEMENT)

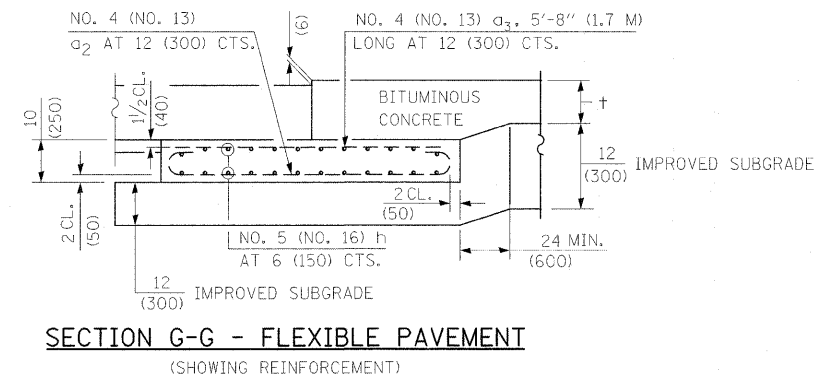

**SECTION G-G - FLEXIBLE PAVEMENT**

(SHOWING REINFORCEMENT)

**GENERAL NOTES**

THICKNESS--"t"--THICKNESS OF PAVEMENT.  
 SEE STANDARD 421001 FOR REINFORCEMENT DETAILS NOT SHOWN.  
 SEE STANDARD 420001 FOR JOINT DETAILS NOT SHOWN.  
 ALL DIMENSIONS ARE IN INCHES (MILLIMETERS) UNLESS OTHERWISE SHOWN.

FILE NAME =	USER NAME = owanbj	DESIGNED -	REVISED -	<b>STATE OF ILLINOIS DEPARTMENT OF TRANSPORTATION</b>	<b>BRIDGE APPROACH PAVEMENT DETAIL</b>			F.A.P. RTE.	SECTION	COUNTY	TOTAL SHEETS	SHEET NO.
et:\pw_work\pwidot\owanj\dms51591\p1n02205b.dgn		DRAWN -	REVISED -					817	421B-1	ST. CLAIR	56	15
PLOT SCALE = 20,0000 ' / IN.		CHECKED -	REVISED -					CONTRACT NO. 76885				
PLOT DATE = 10/18/2008		DATE -	REVISED -					ILLINOIS FED. AID PROJECT				
				SCALE:	SHEET NO. 1 OF 4 SHEETS	STA.	TO STA.					