

**NEW CONSTRUCTION**

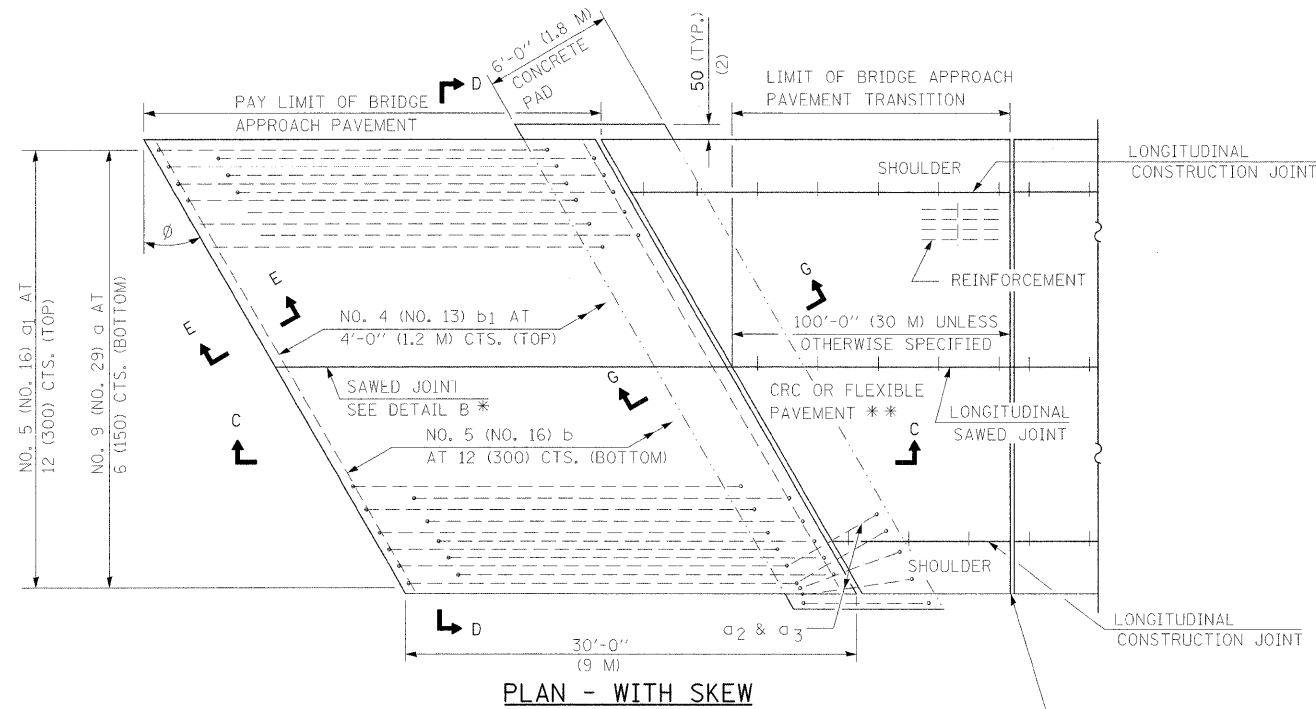

**PLAN - WITH SKEW**

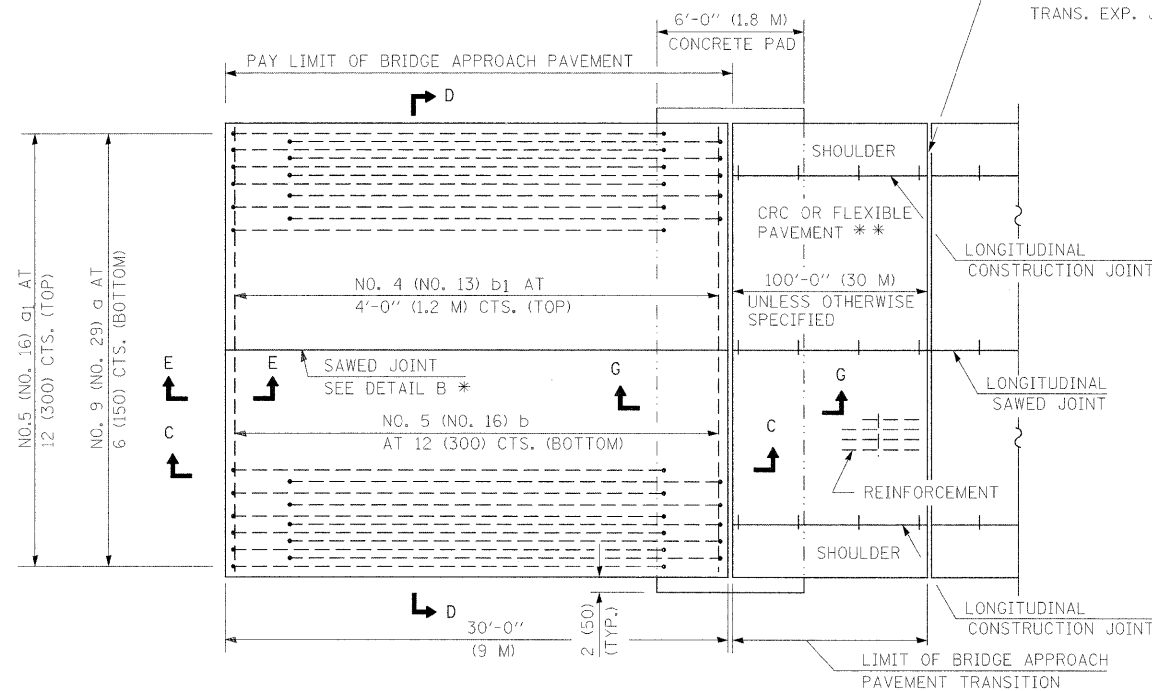

**PLAN - WITHOUT SKEW**

\* SAW  $\phi$  OR LANE EDGE IF POURED TWO OR MORE LANE WIDTHS AT A TIME.  
 \*\* OMIT REINFORCEMENT, TIE BARS AND LONG. SAWED JT. FOR FLEXIBLE PAVEMENT.

RIGID PAVEMENT ONLY:  
 WIDE FLANGE BEAM TERMINAL JOINT (SEE DETAIL AT BEAM - STANDARD 421101 OR 421106) OR 2 (50) TRANS. EXP. JOINT AS DETAILED ON STANDARD 420001.

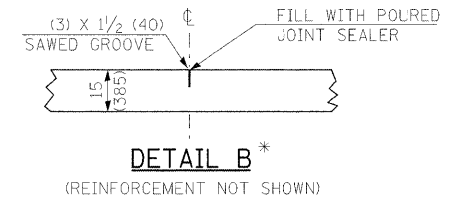

**DETAIL B\***

(REINFORCEMENT NOT SHOWN)

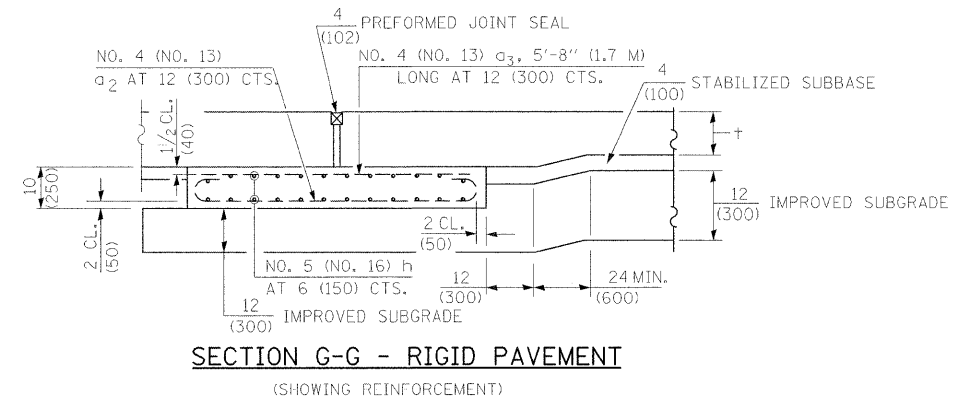

**SECTION G-G - RIGID PAVEMENT**

(SHOWING REINFORCEMENT)

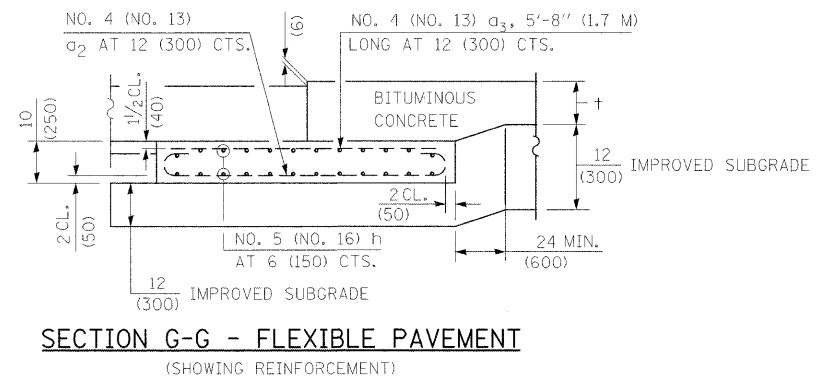

**SECTION G-G - FLEXIBLE PAVEMENT**

(SHOWING REINFORCEMENT)

**GENERAL NOTES**

THICKNESS- $t$ =THICKNESS OF PAVEMENT.  
 SEE STANDARD 421001 FOR REINFORCEMENT DETAILS NOT SHOWN.  
 SEE STANDARD 420001 FOR JOINT DETAILS NOT SHOWN.  
 ALL DIMENSIONS ARE IN INCHES (MILLIMETERS) UNLESS OTHERWISE SHOWN.

FILE NAME =	USER NAME = manntm	DESIGNED -	REVISED -	<b>STATE OF ILLINOIS DEPARTMENT OF TRANSPORTATION</b>	<b>BRIDGE APPROACH PAVEMENT DETAIL</b>	F.A.P. RTE.	SECTION	COUNTY	TOTAL SHEETS	SHEET NO.	
es:\pwork\pwork\manntm\dms51859\p1n02088.dgn	PLOT SCALE = 20.0000 "/ IN.	DRAWN -	REVISED -			10	410BR-1	GREENE	37	12A	
PLOT DATE = 10/16/2008	DATE -	CHECKED -	REVISED -			<b>CONTRACT NO. 76B58</b>					
		DATE -	REVISED -			SCALE:	SHEET NO. 1 OF 4 SHEETS	STA.	TO STA.	FED. ROAD DIST. NO. ILLINOIS FED. AID PROJECT	