

PULLING DEVICE

PARTIAL PLANS

SUGGESTED BEAM STRAIGHTENING METHODS

Straightening force shall be maintained on all load transfer blocking during beam straightening.

PUSHING DEVICE

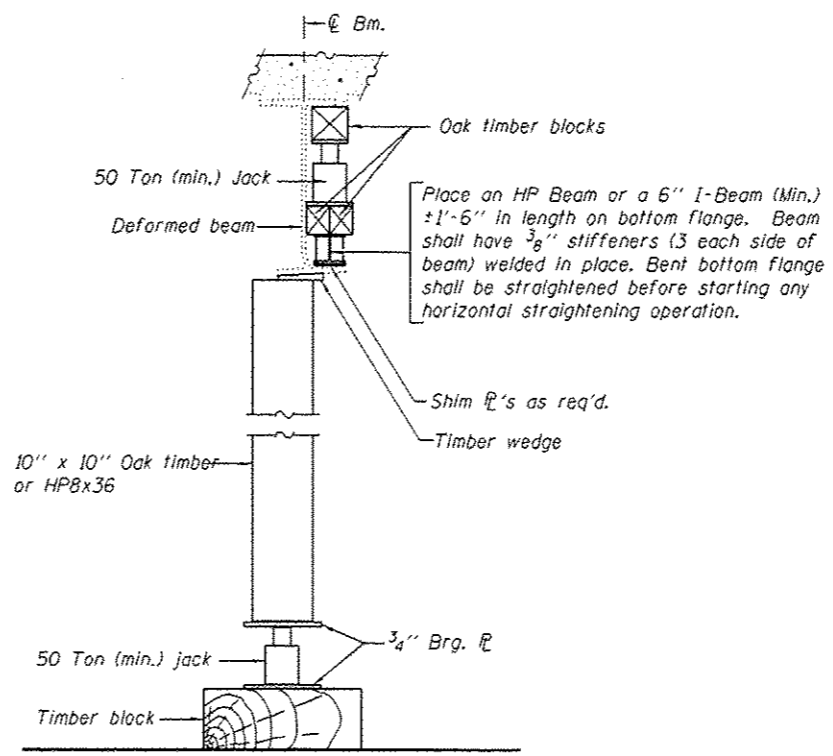

SUGGESTED VERTICAL STRAIGHTENING DETAIL

(To correct flange rotation.)

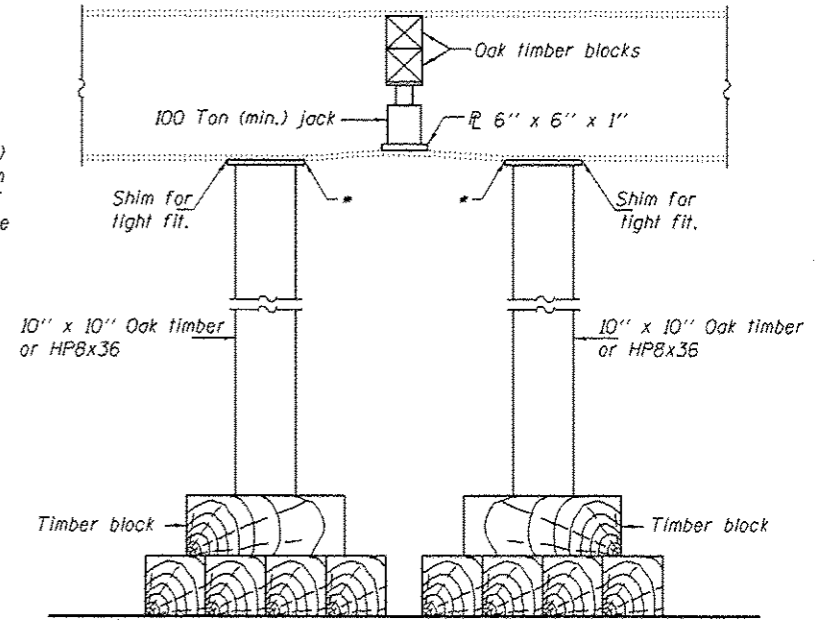

SUGGESTED VERTICAL STRAIGHTENING DETAIL

(To correct localized vertical flange deformations.)

* Edge of plate shall line up with edge of deformation.

Note:
Braces and jack assembly shall be placed on same side of web.
Bent bottom flange shall be straightened before starting any horizontal straightening operations.

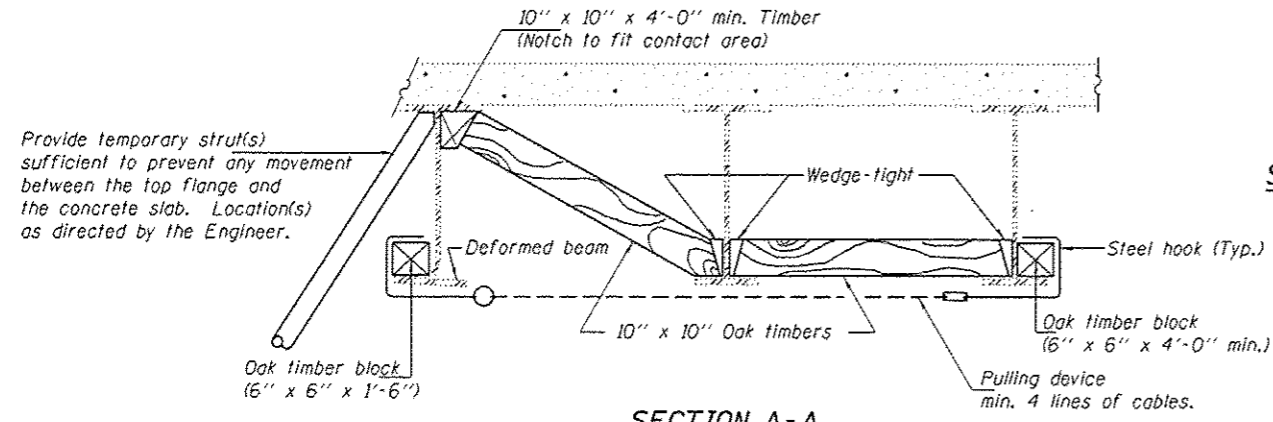

SECTION A-A

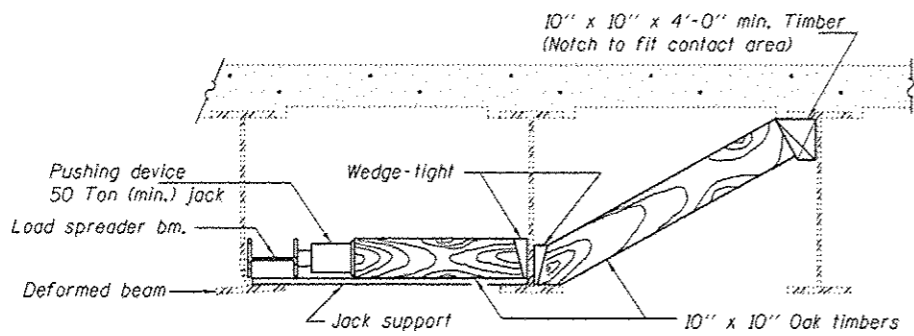

SECTION B-B

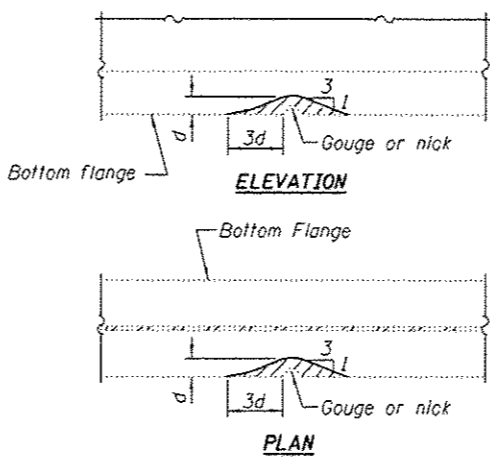

GRINDING DETAIL

Grind existing nicks, gouges and shallow cracks in the damaged beams as detailed. Ground surfaces shall be inspected for cracks using magnetic particle testing prior to initiating any beam straightening operations. Any cracks that cannot be removed by grinding approximately 1/4" deep shall be identified and reported to the Bureau of Bridges and Structures for further disposition. Ground surfaces shall be spot cleaned and painted with an aluminum epoxy mastic primer followed by a finish coat to match the color of the existing beam. Cost of grinding, testing and spot painting included with Beam Straightening.

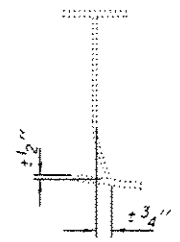

EXISTING DEFORMATION TO BE STRAIGHTENED

(Looking West)
(Approximate max. deflections)
Deflected length of beam to be straightened is approximately 6'.

REP-11-14-2005

DESIGNED - VHV	EXAMINED - <i>Timothy A. ...</i>	DATE - NOVEMBER 15, 2013
CHECKED - DAB	ACTING ENGINEER OF STRUCTURAL SERVICES	
DRAWN - Kyla M. Steffon	PASSED - <i>Carl ...</i>	
CHECKED - VHV DAB	ACTING ENGINEER OF BRIDGES AND STRUCTURES	

STATE OF ILLINOIS
DEPARTMENT OF TRANSPORTATION

BEAM STRAIGHTENING DETAILS
SN 022-0101 (NB) & -0102 (SB)

SHEET NO. 2 OF 2 SHEETS

F.A. RTE.	SECTION	COUNTY	TOTAL SHEETS	SHEET NO.
VAR	2013-044BR	DUPAGE	35	30
CONTRACT NO. 60W94				
ILLINOIS FED. AID PROJECT				