

INTERIOR GIRDER MOMENT TABLE		
		0.5 Sp. 1
I_s	(in ⁴)	11,300
$I_c(n)$	(in ⁴)	26,884
$I_c(3n)$	(in ⁴)	19,288
$I_c(cr)$	(in ⁴)	-
S_s	(in ³)	623
$S_c(n)$	(in ³)	877
$S_c(3n)$	(in ³)	782
$S_c(cr)$	(in ³)	-
DC1	(k/')	0.827
M _{DC1}	('k)	800
DC2	(k/')	0.150
M _{DC2}	('k)	142
DW	(k/')	0.27
M _{DW}	('k)	258
M _{ℓ + IM}	('k)	1,218
M _u (Strength I)	('k)	3,700
φ _r M _n	('k)	4,296
f _s DC1	(ksi)	10.9
f _s DC2	(ksi)	2.2
f _s DW	(ksi)	4.0
f _s (ℓ+IM)	(ksi)	16.7
f _s (Service II)	(ksi)	38.8
0.95R _n F _{yf}	(ksi)	47.5
f _s (Total)(Strength I)	(ksi)	-
φ _r F _n	(ksi)	-
V _f	(k)	24.3

INTERIOR GIRDER REACTION TABLE		
		Abut.
R _{DC1}	(k)	36.4
R _{DC2}	(k)	6.6
R _{DW}	(k)	11.7
R _{ℓ + IM}	(k)	74.9
R _{Total}	(k)	129.6

- I_s, S_s : Non-composite moment of inertia and section modulus of the steel section used for computing f_s (Total-Strength I, and Service II) due to non-composite dead loads (in.⁴ and in.³).
- $I_c(n), S_c(n)$: Composite moment of inertia and section modulus of the steel and deck based upon the modular ratio, "n", used for computing f_s (Total-Strength I, and Service II) in uncracked sections due to short-term composite live loads (in.⁴ and in.³).
- $I_c(3n), S_c(3n)$: Composite moment of inertia and section modulus of the steel and deck based upon 3 times the modular ratio, "3n", used for computing f_s (Total-Strength I, and Service II) in uncracked sections, due to long-term composite (superimposed) dead loads (in.⁴ and in.³).
- $I_c(cr), S_c(cr)$: Composite moment of inertia and section modulus of the steel and longitudinal deck reinforcement, used for computing f_s (Total-Strength I and Service II) in cracked sections, due to both short-term composite live loads and long-term composite (superimposed) dead loads (in.⁴ and in.³).
- DC1: Un-factored non-composite dead load (kips/ft.).
M_{DC1}: Un-factored moment due to non-composite dead load (kip-ft.).
DC2: Un-factored long-term composite (superimposed excluding future wearing surface) dead load (kips/ft.).
M_{DC2}: Un-factored moment due to long-term composite (superimposed excluding future wearing surface) dead load (kip-ft.).
DW: Un-factored long-term composite (superimposed future wearing surface only) dead load (kips/ft.).
M_{DW}: Un-factored moment due to long-term composite (superimposed future wearing surface only) dead load (kip-ft.).
M_{ℓ + IM}: Un-factored live load moment plus dynamic load allowance (impact) (kip-ft.).
M_u (Strength I): Factored design moment (kip-ft.).
1.25 (M_{DC1} + M_{DC2}) + 1.5 M_{DW} + 1.75 M_{ℓ + IM}
φ_rM_n: Compact composite positive moment capacity computed according to Article 6.10.7.1 or non-slender negative moment capacity according to Article A6.1.1 or A6.1.2 (kip-ft.).
f_s DC1: Un-factored stress at edge of flange for controlling steel flange due to vertical non-composite dead loads as calculated below (ksi).
M_{DC1} / S_c
f_s DC2: Un-factored stress at edge of flange for controlling steel flange due to vertical composite dead loads as calculated below (ksi).
M_{DC2} / S_c(3n) or M_{DC2} / S_c(cr) as applicable.
f_s DW: Un-factored stress at edge of flange for controlling steel flange due to vertical composite future wearing surface loads as calculated below (ksi).
M_{DW} / S_c(3n) or M_{DW} / S_c(cr) as applicable.
f_s (ℓ+IM): Un-factored stress at edge of flange for controlling steel flange due to vertical composite live load plus impact loads as calculated below (ksi).
M_{ℓ + IM} / S_c(n) or M_{DW} / S_c(cr) as applicable.
f_s (Service II): Sum of stresses as computed below (ksi).
f_sDC1 + f_sDC2 + f_sDW + 1.3 f_s(ℓ + IM)
0.95R_nF_{yf}: Composite stress capacity for Service II loading according to Article 6.10.4.2 (ksi).
f_s (Total)(Strength I): Sum of stresses as computed below on non-compact section (ksi).
1.25 (f_sDC1 + f_sDC2) + 1.5 f_sDW + 1.75 f_s(ℓ + IM)
φ_rF_n: Non-Compact composite positive or negative stress capacity for Strength I loading according to Article 6.10.7 or 6.10.8 (ksi).
V_f: Maximum factored shear range in span computed according to Article 6.10.10.

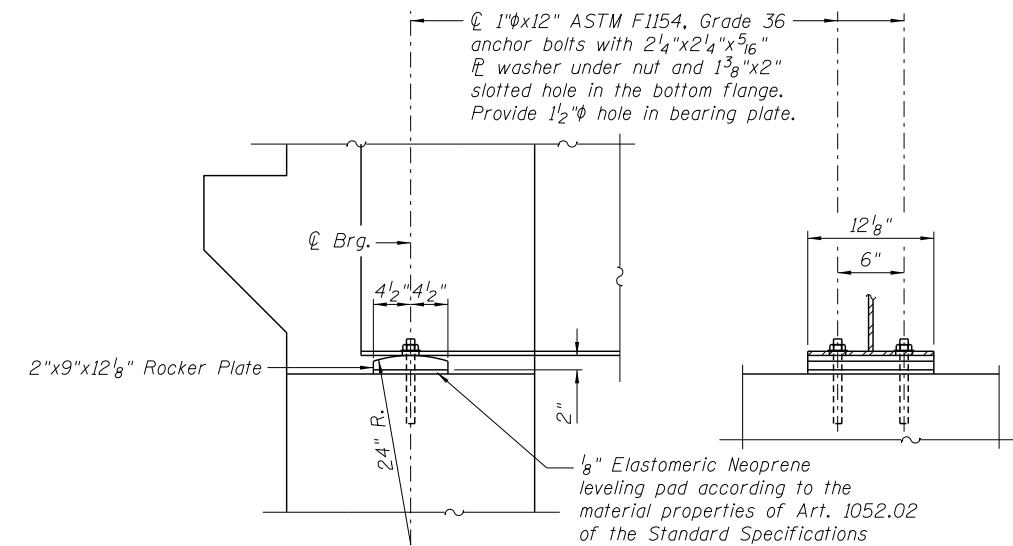

ABUTMENT BEARING DETAILS

Notes:

Anchor bolts shall be ASTM F1554, Grade 36 all-thread (or an Engineer-approved alternate material) of the grade(s) and diameter(s) specified. The corresponding specified grade of AASHTO M314 anchor bolts may be used in lieu of ASTM F1554.

Anchor bolts at fixed bearings may be either cast in place or installed in holes drilled after the supported member is in place.

Drilled and set anchor bolts shall be installed according to Article 521.06 of the Standard Specifications.

All plates and pintles of the Bearing Assembly shall conform to the requirements of AASHTO M270 Grade 50W.

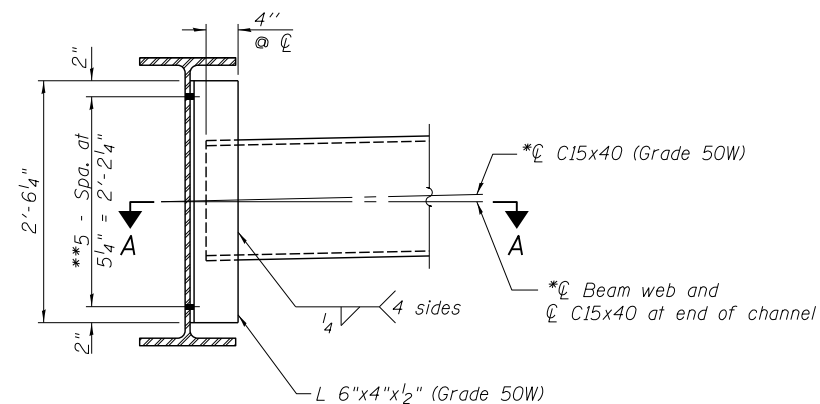

INTERIOR DIAPHRAGM
(25 Required)

Notes:

Two hardened washers required for each set of oversized holes.
*Alternate channels C15X50 are permitted to facilitate material acquisition. Calculated weight of structural steel is based on the lighter section.
The alternate, if utilized, shall be provided at no additional cost to the Department.
**3/4" HS bolts, 1 5/16" φ holes.

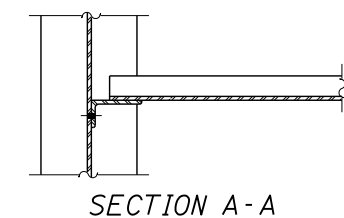

BILL OF MATERIAL

Item	Unit	Total
Anchor Bolts, 1"	Each	24

FILE NAME = ...E4DB4-SN0000051-014-SteelDetails.dgn



Zroka Engineering, P.C.
4216 North Hermitage
Chicago, IL 60613

USER NAME = SAW	DESIGNED - PMM	REVISED -
	CHECKED - DAZ	REVISED -
PLOT SCALE = 0:2.0000 '1' / in.	DRAWN - SAW	REVISED -
PLOT DATE = 8/1/2013	CHECKED - PMM	REVISED -

STATE OF ILLINOIS
DEPARTMENT OF TRANSPORTATION

STRUCTURAL STEEL DETAILS
S.N. 098-0051

SHEET NO. 14 OF 19 SHEETS

F.A.P. RTE.	SECTION	COUNTY	TOTAL SHEETS	SHEET NO.
646	5BR-3	CARROLL	84	37
ILLINOIS FED. AID PROJECT				CONTRACT NO. 64DB4