

GENERAL NOTES

Layout of slope and structure may be varied to suit ground conditions in the field as directed by the Engineer.

The design fill height for this structure is maximum 2.27 feet and minimum 2.00 feet at edge of shoulder. The precast concrete box culvert sections shall conform to the requirements of ASTM C1577.

Areas of the precast box culvert in contact with cast-in-place concrete shall be sand blasted, cleaned, and wetted prior to placing concrete in the field according to Article 503.09(b) of the Standard Specifications.

In order to minimize excessive deflection and/or stresses in the soldier piles, compaction equipment used within 4 feet of the back face of the timber lagging shall be limited to lightweight mechanical tampers, rollers, or vibratory systems.

Build top of headwalls parallel to the grade lines.

All construction joints shall be bonded according to Article 503.09 of the Standard Specifications.

End Sections will be paid for at the contract unit price each for BOX CULVERT END SECTIONS, Culvert No. 2 as outlined in Section 540 of the Standard Specifications.

The box culvert end section shall be built in the field and a precast option is not allowed. Class SI concrete shall be used for the concrete cast in the field for the cutoff walls, portions of the end sections being cast onto the end of the precast box sections, and the concrete facing for the walls.

Concrete, rebar, and welded wire fabric quantities and lengths calculated for the end sections may vary based upon the precast box culverts supplied.

The ends of the precast box sections adjacent to the end sections shall be formed without the tongue and groove shapes specified in Article 8.1 of ASTM C1577.

The longitudinal reinforcement of the welded wire fabric extending from the precast boxes into the end sections shall have a minimum area of 0.20 in ²/ft. Substitution of reinforcement bars for welded wire fabric is not allowed.

The joints between precast box sections shall be sealed and all voids filled with a mastic joint sealer. In addition, the joints shall be externally sealed on all four sides with a 13 inch wide external sealing band. The seal shall be centered over the joint, secured in place, and protected during the backfilling process.

Contractor shall excavate behind existing abutments prior to removal of superstructure to balance front and back soil pressure.

Due to low fill, provide Membrane Waterproofing for Culverts over the top of the culvert. See Special Provisions.

Note:

See sheet 2 of 7 for dimensions, piles and weepholes.
See sheet 4 of 7 for Sections B-B thru E-E.
See sheet 5 of 7 for Section F-F.

Extend precast concrete box culvert welded wire fabric into end section. Bend as necessary to provide 1/2" clear cover.

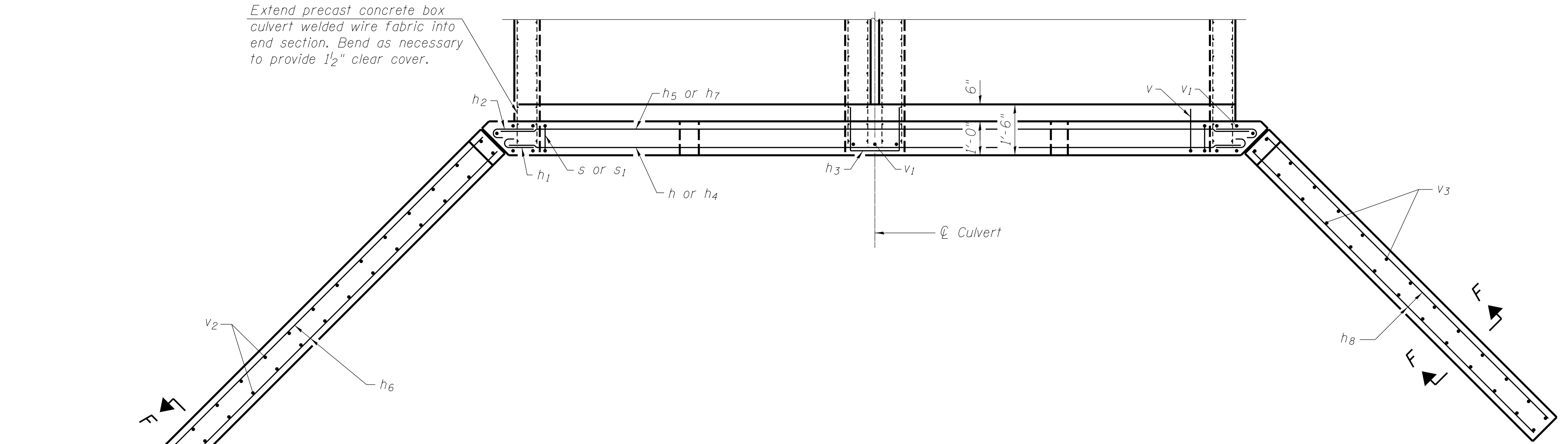

PLAN

(Typ. Each End)
(Showing reinforcement. Piles not shown for clarity)

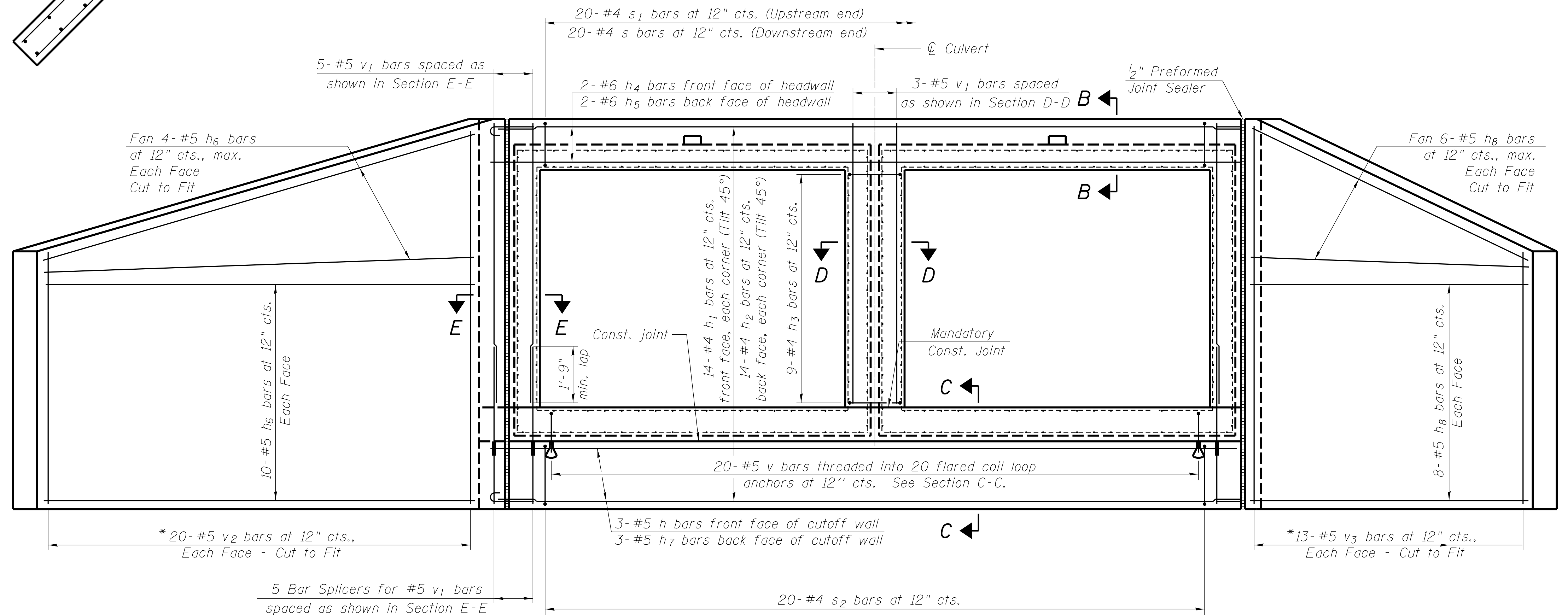

END ELEVATION

(Showing reinforcement. Piles not shown for clarity)

* See sheet 4 of 7 for Field Cutting Diagram..



USER NAME =	DESIGNED - CJB	REVISED -
PLOT SCALE =	CHECKED - CCF	REVISED -
PLOT DATE =	DRAWN - CCF	REVISED -
	CHECKED - CJB	REVISED -

**STATE OF ILLINOIS
DEPARTMENT OF TRANSPORTATION**

**BOX CULVERT END SECTION DETAILS
STRUCTURE NO. 050-2056**

SHEET NO. 3 OF 7 SHEETS

F.A.P. RTE.	SECTION	COUNTY	TOTAL SHEETS	SHEET NO.
786	(110) BR-3	LASALLE	69	36
CONTRACT NO. 66B19				

ILLINOIS FED. AID PROJECT