

TYPICAL SECTION

STA. 968+46.00 TO STA. 972+50.00

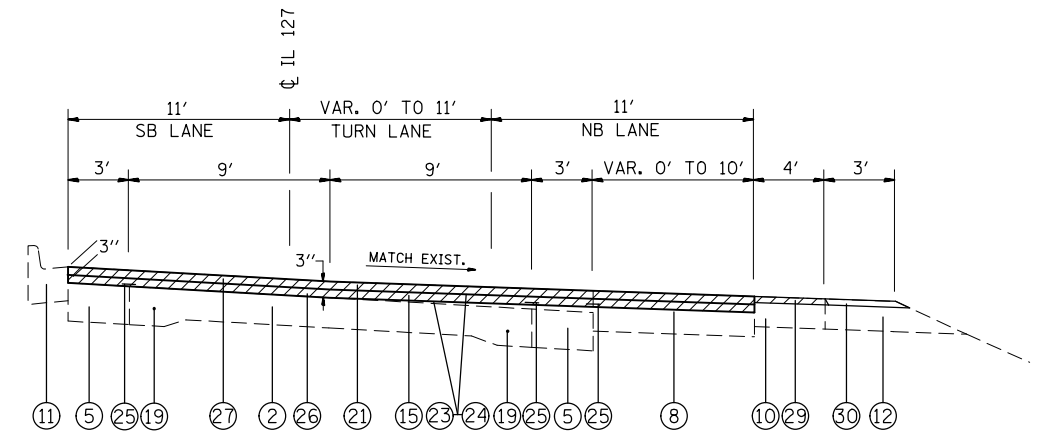

TYPICAL SECTION

STA. 1384+97.20 TO STA. 1386+33.06

NOTE: THE HMA SURFACE REMOVAL OF THE VARIABLE DEPTH SURFACE WILL BE INCLUDED IN THE PAY ITEM "HMA SURFACE REMOVAL 3 3/4"

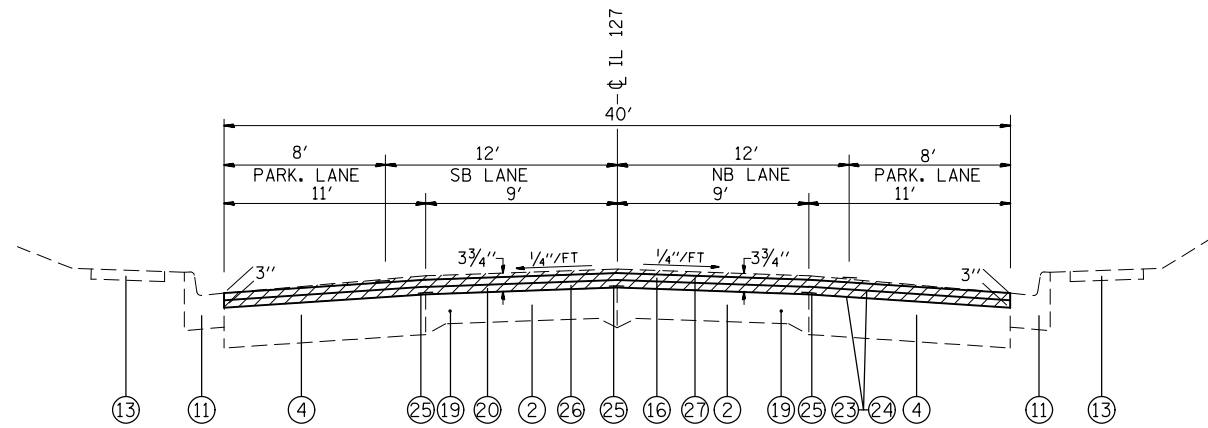

TYPICAL SECTION

STA. 972+50.00 TO STA. 1384+97.20*

*STA. EQUATION
978+29.08 BK =
1375+26.92 AH

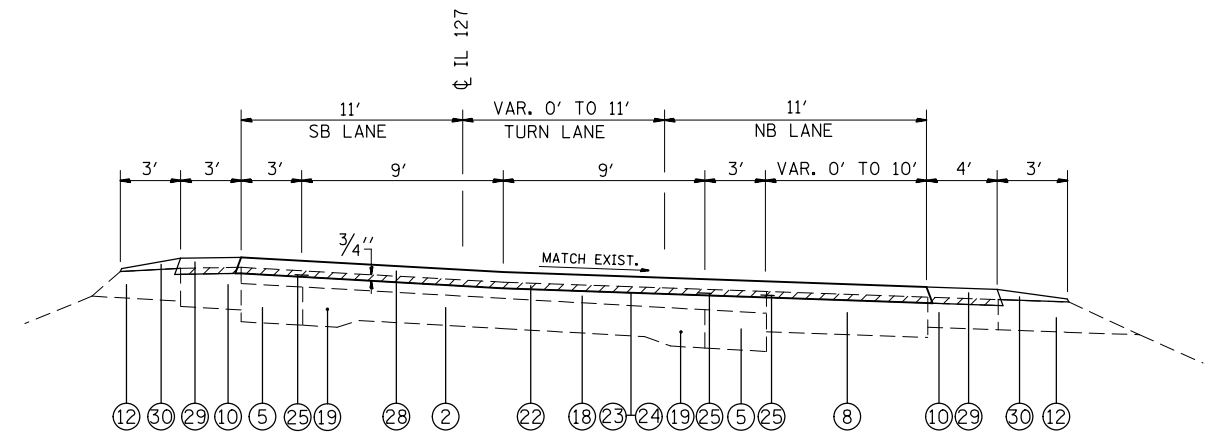

TYPICAL SECTION

STA. 1386+33.06 TO STA. 1400+66.93**

**STA. EQUATION
1400+66.93 BK =
1408+51.90 AH

LEGEND

- ① EXISTING PCC PAVEMENT 9-6 1/2-9
- ② EXISTING PCC PAVEMENT 9-6-9
- ③ EXISTING PCC PAVEMENT 9"
- ④ EXISTING CONCRETE WIDENING, 8"
- ⑤ EXISTING CONCRETE WIDENING, 9"
- ⑥ EXISTING HMA BASE COURSE WIDENING 12"
- ⑦ EXISTING HMA WIDENING 10"
- ⑧ EXISTING HMA WIDENING 13 3/4"
- ⑨ EXISTING HMA SHOULDER 9 3/4"
- ⑩ EXISTING HMA SHOULDER 8"
- ⑪ EXISTING COMBINATION CURB & GUTTER TYPE B-6.24
- ⑫ EXISTING AGGREGATE SHOULDER
- ⑬ EXISTING CONCRETE SIDEWALK
- ⑭ EXISTING LONGITUDINAL METAL JOINT
- ⑮ EXISTING HMA RESURFACING 3"
- ⑯ EXISTING HMA RESURFACING 3 3/4"
- ⑰ EXISTING HMA RESURFACING 2 1/2"
- ⑱ EXISTING HMA RESURFACING 4"
- ⑲ EXISTING 3/4" ROUND SMOOTH BAR
- ⑳ PROPOSED HMA SURFACE REMOVAL 3 3/4"
- ㉑ PROPOSED HMA SURFACE REMOVAL 3"
- ㉒ PROPOSED HMA SURFACE REMOVAL 3/4"
- ㉓ PROPOSED BITUMINOUS MATERIALS (PRIME COAT)
- ㉔ PROPOSED AGGREGATE (PRIME COAT)
- ㉕ PROPOSED STRIP REFLECTIVE CRACK CONTROL TREATMENT
- ㉖ PROPOSED LEVELING BINDER (MACHINE METHOD), 1 1/2"
- ㉗ PROPOSED POLYMERIZED HMA SURFACE COURSE, MIX D, N90 1 1/2"
- ㉘ PROPOSED POLYMERIZED HMA SURFACE COURSE, MIX D, N90 2 1/4"
- ㉙ PROPOSED HMA SHOULDERS, 2 1/4"
- ㉚ PROPOSED AGGREGATE WEDGE SHOULDER, TYPE B

FILE NAME =	USER NAME = dntelmonjn	DESIGNED -	REVISD -
et:\pw\work\p\dot\dntelmonjn\d0287304\d876f47-sht-plan.dgn		DRAWN -	REVISD -
	PLOT SCALE = 100.0000' / in.	CHECKED -	REVISD -
	PLOT DATE = 10/18/2013	DATE -	REVISD -

STATE OF ILLINOIS
DEPARTMENT OF TRANSPORTATION

TYPICAL SECTIONS		F.A.P. RTE. 42	SECTION 102-1RS-3,102-TS	COUNTY WASHINGTON	TOTAL SHEETS 46	SHEET NO. 9
SCALE: _____	SHEET NO. ____ OF ____ SHEETS	STA. _____	TO STA. _____	CONTRACT NO. 76F47		
FED. ROAD DIST. NO. _ ILLINOIS FED. AID PROJECT						