

**PLAN THROUGH PARAPET**

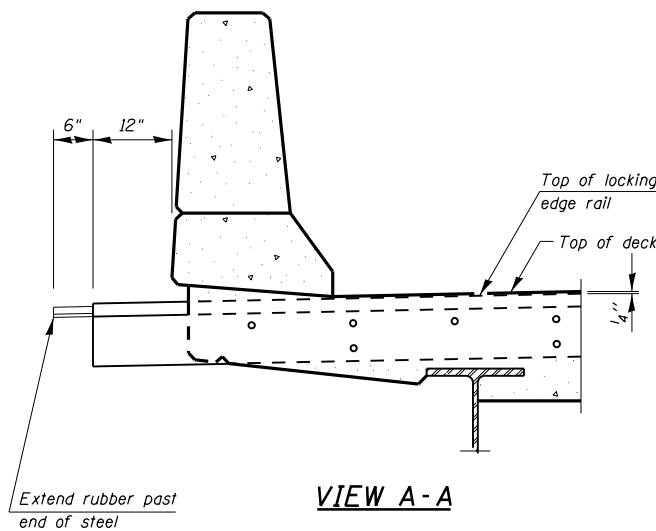

**VIEW A-A**

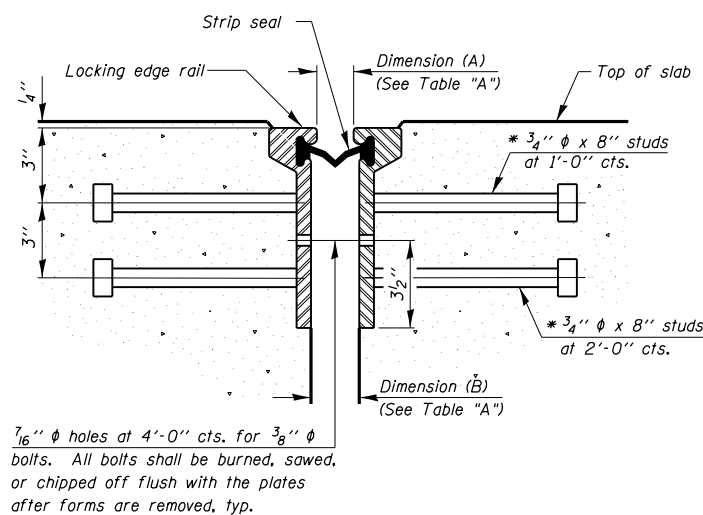

**SECTION THRU  
ROLLED RAIL JOINT**

\* Granular or solid flux filled headed studs conforming to Article 1006.32 of the Std. Specs., automatically end welded.

**Notes:**  
The strip seal shall be made continuous and shall have a minimum thickness of 1/4". The configuration of the strip seal shall match the configuration of the Locking Edge Rails. Open or "webbed" strip seal gland configurations are not permitted. The gland shall be sized for a maximum rated movement of 4 inches.  
The Locking Edge Rails depicted are conceptual only, except for the minimum dimensions shown. The actual configuration of the Locking Edge Rails and matching strip seal may vary from manufacturer to manufacturer. Flanged edge rails will not be allowed. Locking Edge Rails may be spliced at slope discontinuities.  
The manufacturer's recommended installation methods shall be followed.  
The joint opening and deck dimensions detailed on the superstructure are based on a rolled rail expansion joint. If the Contractor elects to use the welded rail expansion joint, the opening and deck dimensions shall be modified according to the dimensions detailed on this sheet. Required modifications shall be made at no additional cost to the State.  
All steel components shall be galvanized after fabrication according to Article 520.03 of the Standard Specifications.  
Maximum space between rail segments shall be 3/16", sealed with a suitable sealant. Joints in rails within 10 ft. of curbs shall be welded.  
Parapet plates and anchorage studs for skews > 30° included in the cost of Preformed Joint Strip Seal.

**TABLE "A"**

(All dimensions @ 50° F)

Joint	A	B	C
W. Abut.	1 1/2"	2"	2 3/4"
E. Abut.	1 1/2"	2"	2 3/4"

**BILL OF MATERIAL**

Item	Unit	Total
Preformed Joint Strip Seal	Foot	182

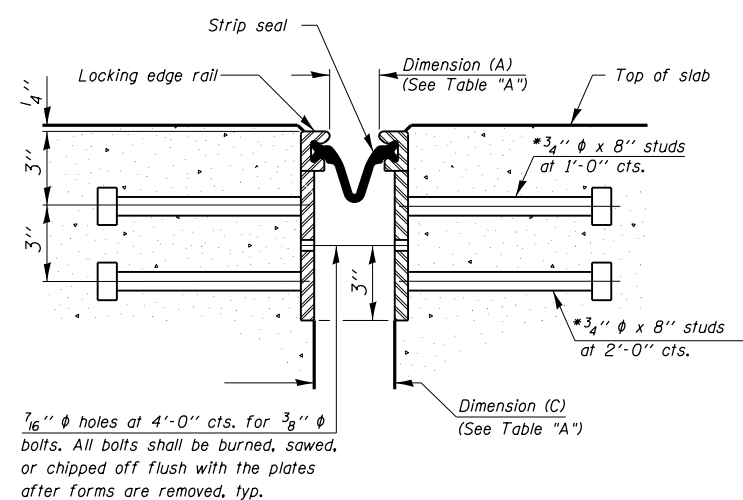

**SECTION THRU  
WELDED RAIL JOINT**

**LOCKING EDGE RAILS**

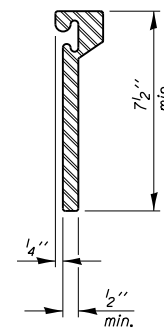

**ROLLED  
EXTRUDED RAIL**

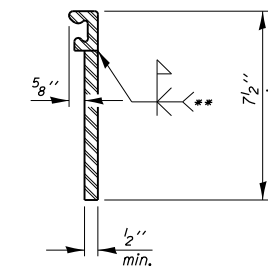

**WELDED RAIL**

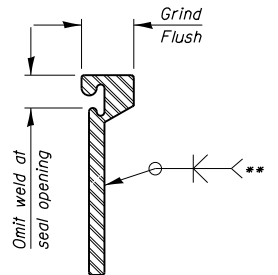

**LOCKING EDGE  
RAIL SPLICE**

The inside of the locking edge rail groove shall be free of weld residue. Rolled rail shown, welded rail similar.  
\*\* Back gouge not required if complete joint penetration is verified by mock-up.

**Notes:**  
Post shall be normal to the parapet.  
\* In lieu of the cast-in-place anchor device shown, the Contractor has the option of drilling and setting stainless steel anchor rods of the same diameter and grade as the specified cap screws according to Article 509.06 of the Standard specifications. Embedment shall be according to the manufacturers's specifications.  
Removal and re-erection of the existing aluminum handrail, rail post, and all new applicable hardware, including labor and installation shall be included in the cost of CONCRETE REMOVAL.

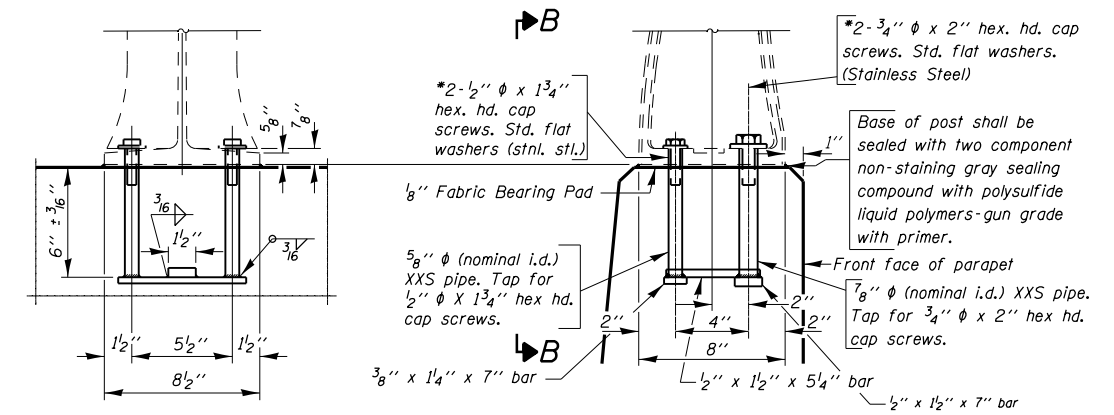

**VIEW B-B**

**RAIL POST DETAILS**

**PREFORMED JOINT STRIP SEAL  
AND RAIL POST DETAILS  
SN 064-0029**