

HALE STREET REHABILITATION

PLANO, ILLINOIS

F.A.U. RTE 6474

SECTION: 22-00049-00-PV

CONTRACT No. 87873

STATION 102+26 TO STATION 126+56

RUBINO PROJECT No. G23.171

***Roadway
Geotechnical
Report***

*Drilling
Laboratory Testing
Geotechnical Analysis*

**Authors:
Jonathan Ignarski**

**Reviewed By:
David T. Lewandowski, PE**

rubino
ENGINEERING INC.

**425 Shepard Dr, Elgin, IL 60123
(847) 931-1555**

**Reviewed By:
Michelle A. Lipinski, PE
President
michelle.lipinski@rubinoeng.com
IL No. 062-061241, Exp. 11/30/25**

PREPARED FOR:

HR GREEN, INC.

2363 SEQUOIA DRIVE

SUITE 101

AURORA, ILLINOIS

NOVEMBER 4, 2024

TABLE OF CONTENTS

PROJECT DESCRIPTION, LOCATION AND SCOPE - 1 -

GEOLOGY AND PEDOLOGY - 1 -

FIELD EXPLORATION - 2 -

 DRILLING, FIELD, AND LABORATORY TESTS - 2 -

Table 1: Drilling Scope - 2 -

 SURFACE CONDITIONS - 3 -

Table 2: Existing Pavement Section Summary - 3 -

 SUBSURFACE CONDITIONS - 3 -

 GROUNDWATER AND CLIMATIC CONDITIONS - 4 -

ANALYSIS AND RECOMMENDATIONS - 5 -

 EMBANKMENT FILL MATERIALS - 5 -

 EXPANSIVE SOILS DISCUSSION - 6 -

Table 3: Expansive Soils by Location - 6 -

 SUBGRADE SUPPORT RATING (SSR) - 6 -

 SUBSURFACE DRAINAGE - 6 -

 SUBGRADE IMPROVEMENT RECOMMENDATIONS - 7 -

Table 4: Undercut Recommendations - 7 -

CLOSING - 8 -

- Appendix A – Site Vicinity Map
- Appendix B – Proposed Typical Sections
- Appendix C – Preliminary Plans and Profiles
- Appendix D – Geology and Pedology Maps
- Appendix E – Pavement Core Summary Table
- Appendix F – Boring Logs and Subsurface Profile
- Appendix G – Laboratory Test Results
- Appendix H – Report Limitations

PROJECT DESCRIPTION, LOCATION AND SCOPE

Rubino Engineering, Inc. (Rubino) understands that the Hale Street Rehabilitation project includes approximately 2,000 feet of Hale Street between US 34 and E Larson Street (see Appendix A – Site Vicinity Map). The project consists of roadway reconstruction, resurfacing and sidewalk/shared-use path installation. Roadway reconstruction is planned from station 107+25.00 to station 123+97.00. Roadway resurfacing is planned on the south and north ends of the project from station 102+26 to station 107+25.00 and station 123+97.00 to station 126+56.00. The proposed sidewalk/shared-use path will be installed on the west side of Hale Street.

The proposed pavement for the reconstruction areas consists of 8 inches of HMA and 12 inches of aggregate subgrade improvement. Based on the proposed profile, the final pavement grades appear to be within approximately ½-foot of existing grades.

This report presents the results of the roadway geotechnical field and laboratory investigations, along with engineering analyses, and recommendations performed by Rubino. The geotechnical recommendations presented in this report are based on the available project information and the subsurface materials described in this report.

GEOLOGY AND PEDOLOGY

The ground elevation in the area of exploration ranges from 646 feet to 648 feet along S. Hale Street as you travel north to south. This change in elevation throughout the project site is most likely attributed to flooding events as well as water-based erosion along tributaries such as Big Rock Creek to the Fox River. See Appendix D – Geology and Pedology Maps.

The geomorphology of Kendall County resulted primarily from the advance of continental glaciers during the last glaciation (Wisconsin Episode; 30,000 – 14,600 years B.P.). The westward advance of these glaciers was controlled by preexisting bedrock highs or preexisting moraines from older glacial episodes (Illinois Episode; 200,000 - 130,000 years B.P.). The glacial ice sheets that covered Kendall County deposited various end moraines and their associated ground moraines. Moraines present within Kendall County include the Elburn Morainic Complex, St. Charles Moraine, Marseilles Moraine, and

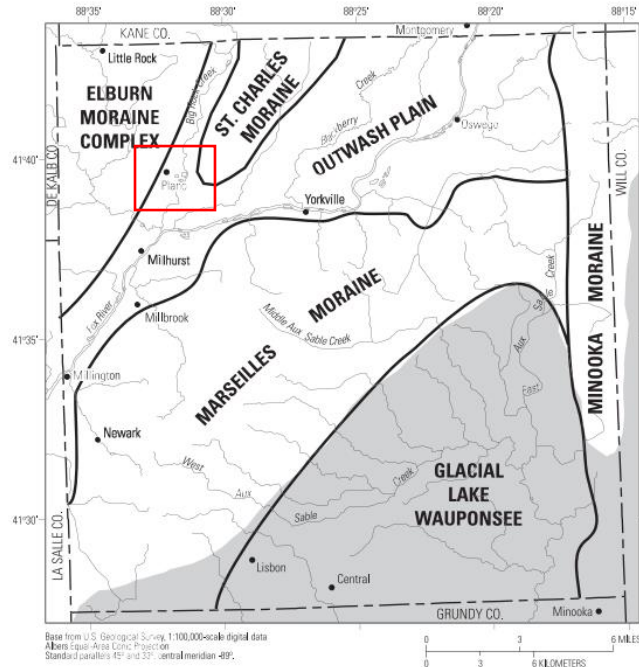

Figure 1. Moraines of Kendall County, Illinois.
Modified from Kay et al., 2005.



Minooka Moraine (*Figure 1*). As these ice sheets dammed streams and rivers, glacial and post-glacial lakes such as Glacial Lake Wauponsee (*Figure 1*) formed across most of Kendall County.

A review of the Surface-Water and Ground-Water Resources of Kendall County, Illinois (Kay et al., 2005) reveals that the area of exploration is dominated by three major glacial units: The fine-grained tills of the Lemont Formation of the Wedron Group and the outwash sands and gravels and lacustrine deposits of the Equality and Henry Formations of the Mason Group (*Figure 2*; See *Appendix*). The Elburn Morainic Complex is composed primarily of the Lemont Formation consisting of gray silty clay to sandy loam with lenses of sand and gravel. The St. Charles, Marseilles, and Minooka Moraines are composed primarily of the Yorkville Member of the Lemont Formation consisting of gray silty clay with local lenses of silt and small gravel. Glacial Lake Wauponsee is composed primarily of the Equality Formation containing silt, clay, and organic debris with local lenses of gravel, sand, and diamicton. Coarse-grained outwash sands and gravels of the Henry Formation interfinger with the finer-grained deposits of the Wedron Group throughout the county (*Figure 1*).

Other formations present within the area of exploration include alluvial deposits of the Cahokia Formation which flank most of the Fox River, Blackberry Creek, and Big Rock Creek (*Figure 2*; See *Appendix*). Loess deposits of the Peoria Silt overlie most of the glacial deposits and are the basis of modern-day soils. Bedrock in Kendall County consists of Silurian dolomite and Ordovician shale and argillaceous dolomite.

FIELD EXPLORATION

Drilling, Field, and Laboratory Tests

In consultation with the client, Rubino selected the number of borings and the boring depths. Rubino located the borings in the field by measuring distances from known fixed site features. Rubino mobilized to site on December 7, 2023. The borings were advanced by Rubino using a Geoprobe 7822DT with 2 ¼ inch inside-diameter, hollow stem auger drilling methods and soil samples were routinely obtained during the drilling process. Rubino is preparing this RGR based on the following soil borings:

Table 1: Drilling Scope

BORING No.	DATE	STATION	OFFSET	SURFACE ELEVATION (FEET)	DRILLING DEPTH (FEET BEG*)
B-01	12/7/23	124+04.16	9.88	676.97	15
B-02	12/7/23	116+80.91	-11.12	647.00	15
B-03	12/7/23	107+81.68	-15.58	647.95	15

*BEG = Below existing grade



Selected soil samples were tested in the laboratory to determine material properties for this report. Drilling, sampling, and laboratory tests were accomplished in general accordance with AASHTO procedures. The following items are further described in the Appendix of this report.

- *Standard Penetration Tests and Split-Barrel Sampling of Soils (AASHTO T 206)*
- *Field Water Level Measurements*
- *Laboratory Determination of Water (Moisture) Content of Soil by Mass (AASHTO T 265-15)*
- *Laboratory Determination of Atterberg Limits (AASHTO 89-13 and T 90-15)*
- *Laboratory Organic Content by Loss on Ignition (AASHTO T 267-86)*

The results of these tests can be found on the accompanying boring logs located in Appendix F and Laboratory Test Results in Appendix G.

Surface Conditions

Cores were taken within the existing pavement of Hale Street. The surface conditions are as follows:

Table 2: Existing Pavement Section Summary

CORE No.	STATION	TOTAL OBSERVED PAVEMENT THICKNESS	TOTAL OBSERVED BASE STONE THICKNESS
B-01	124+04.16	8 ¼ INCHES OF ASPHALT	6 INCHES OF SUBBASE STONE
B-02	116+80.91	7 INCHES OF ASPHALT	7 INCHES OF SUBBASE STONE
B-03	107+81.68	4 ½ INCHES OF ASPHALT	8 ½ INCHES OF SUBBASE STONE

Please note that the above referenced thicknesses are considered approximate and based on visual observations and hand measurements. Pavement and sub-base type and thickness may vary between core locations.

Subsurface Conditions

Soils generally consisted of possible fill (cohesive), brown high plasticity silty clay, brown and/or gray silty clay to silty clay loam, brown silt, and brown sand. Detailed descriptions of the soils encountered are presented in the attached Boring Logs in Appendix F.



Groundwater and Climatic Conditions

Groundwater was not encountered in the borings along Hale Street during drilling operations. However, it should be noted that fluctuations in the groundwater level should be anticipated throughout the year depending on variations in climatological conditions and other factors not apparent at the time the borings were performed. Groundwater may not have been observed in some areas due to the low permeability of soils. Additionally, discontinuous zones of perched water may exist within the soils. The possibility of groundwater level fluctuation should be considered when developing the design and construction plans for the project.

The subsurface investigation for the proposed Hale Street Rehabilitation in Plano, Illinois were performed during the month of December 2023. To assess the possible effects of temperature and precipitation on groundwater level and soil moisture during the investigation, the climatic conditions from July 2023 through December 2023 are summarized graphically, below.

The precipitation and temperature data for the investigation period are compared against thirty-year monthly data (1981 to 2010) to illustrate deviations from “normal” climate conditions during the current investigation. Local climatologic data were obtained from the NOAA Morton Arboretum Station in Lisle, Illinois, the NOAA Plano Station in Plano, Illinois, and the NOAA Aurora Station in Aurora, Illinois.

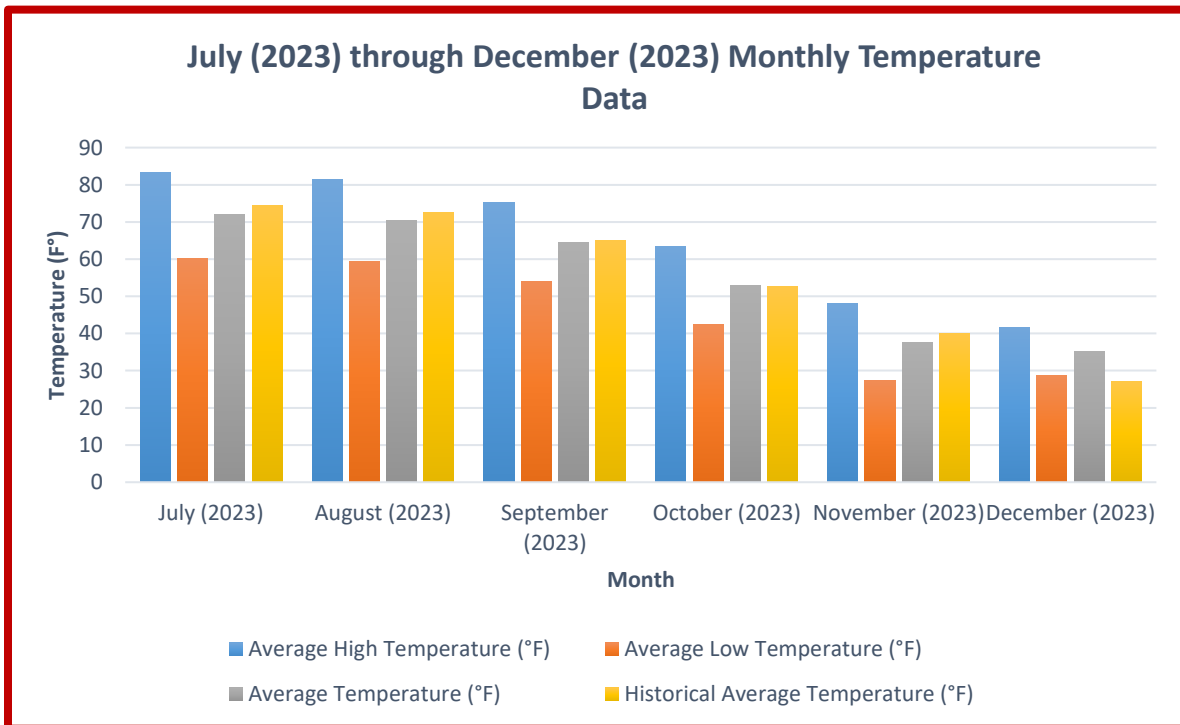

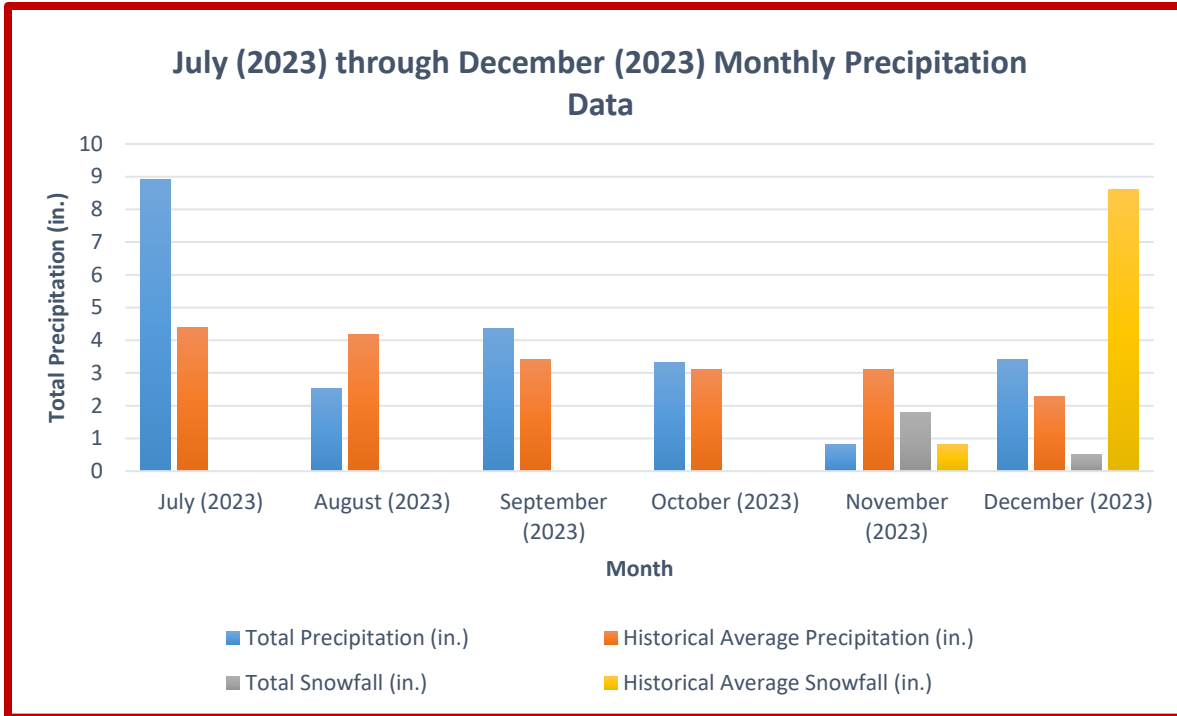

Higher than average precipitations were recorded for the months of July, September, October, and December 2024.

No significant effects on moisture content and water table data are considered likely. However, groundwater may be affected by seasonal water table fluctuations.

ANALYSIS AND RECOMMENDATIONS

Embankment Fill Materials

Based on the proposed profile, significant fills will not be required to achieve final grades. In the event fills are required, see the District 3 Borrow and Furnish Special for material requirements. If design changes, please notify Rubino and additional recommendations can be provided upon request.



Expansive Soils Discussion

Soils with expansive properties (LL>50) were observed in boring B-03 during drilling operations. Table 3 summarizes the expansive (LL>50) encountered along the project site.

Table 3: Expansive Soils by Location

BORING	STATION	SOIL CLASSIFICATION	ELEVATION RANGE (FEET)	PLASTICITY INDEX (PI)	SILT AND FINE SAND CONTENT (%)	LIQUID LIMIT (LL)	EXPANSIVE OR FROST SUSCEPTIBLE
B-03	107+81.68	Brown HIGH PLASTICITY SILTY CLAY	646.95 – 640.95	33	N/A	59	Expansive

Subgrade Support Rating (SSR)

Subgrade Support Rating (SSR) testing was outside the original scope for the project. However, for design purposes, a Subgrade Support Rating (SSR) of poor is recommended for existing subgrade soils.

Subsurface Drainage

Proper surface grading should be incorporated into design and construction of subgrade and pavement to remove water accumulations and prevent ponding of water. Rubino recommends that longitudinal underdrains be incorporated into the design to provide the dissipation of water that accumulates in the aggregate subgrade improvement. Additionally, transverse underdrains are recommended in areas of low elevation and high plasticity silty clay (B-03) along the proposed roadway alignment. Where undercuts are performed and replaced with aggregate, the underdrains should be lowered such that water is accepted at the lowest point of the undercut and removed accordingly. These recommendations are made in accordance with the IDOT Geotechnical Manual (2020).

The underdrains should tie into the storm water drainage system and should be installed per Article 601 in the IDOT Standard Specifications for Road and Bridge Construction (Adopted January 1, 2022) and consist of Type 3 underdrains.



Subgrade Improvement Recommendations

The recommendations located in this report are based on the data obtained at each particular soil boring location. Soil subgrade stability may vary in the field between the borings and could be affected by the weather at the time of construction.

- See IDOT IBV Based Remedial Action chart from the IDOT Subgrade Stability Manual for reference.
- IDOT requires the use of subgrade improvement below proposed pavement.
 - The proposed plans state the entire length of the improvements will contain 12 inches of aggregate subgrade improvement (SY).
 - Accordingly, subgrade with an IBV value of less than 3 is a candidate for remediation when incorporating aggregate subgrade improvement.
- Subgrade with a moisture content exceeding 25% may result in a lower IBV which may be a candidate for remedial action.
- If unsuitable soils are encountered in the field during construction, it is recommended that the soil be removed and replaced with material meeting the IDOT Aggregate Subgrade Improvement Special Provision.
- Geotextile fabric should be placed at the base of undercut areas where low strength subgrade soils are encountered. Fabric should meet the requirements of Section 210, Fabric For Ground Stabilization, per the SSRBC (January 1, 2022).
- Expansive soils have the potential to heave during freeze-thaw cycles and require remediation. Please see the Expansive Soils Discussion section for further details

Unstable soil should be treated in accordance with Article 301.04 of the standard specifications and undercut guidelines in the IDOT Subgrade Stability Manual 2005:

Table 4: Undercut Recommendations

STATIONS		PAVEMENT TREATMENT WIDTH	AGGREGATE THICKNESS	REMEDICATION METHOD	REFERENCE BORING SUBGRADE CONCERNS (BORING NUMBER)
FROM	TO				
107+25	112+50	Full Width	18 - 24 inches	Remove and replace with Agg. Subgrade Improvement underlain by Fabric	(B-03): Expansive soils to approximately 6 feet below existing grade

The aggregate thickness depth range detailed in *Table 4* is measured from the bottom of the proposed pavement and includes the 12-inch Aggregate Subgrade Improvement (SY) detailed in the project plans. The actual need for removal and replacement with Aggregate Subgrade Improvement should be determined in the field at the time of construction by the Geotechnical Engineer or Soils Inspector.



CLOSING

The recommendations submitted are based on the available subsurface information and design details furnished by HR Green, Inc. for the proposed project. If there are any revisions to the plans for this project or if deviations from the subsurface conditions noted in this report are encountered during construction, Rubino should be notified immediately to determine if changes in our recommendations are required.

This report has been prepared for the exclusive use of HR Green, Inc. and their consultants for the specific application to the Hale Street Rehabilitation Project in Plano, Illinois.



Appendix A – Site Vicinity Map

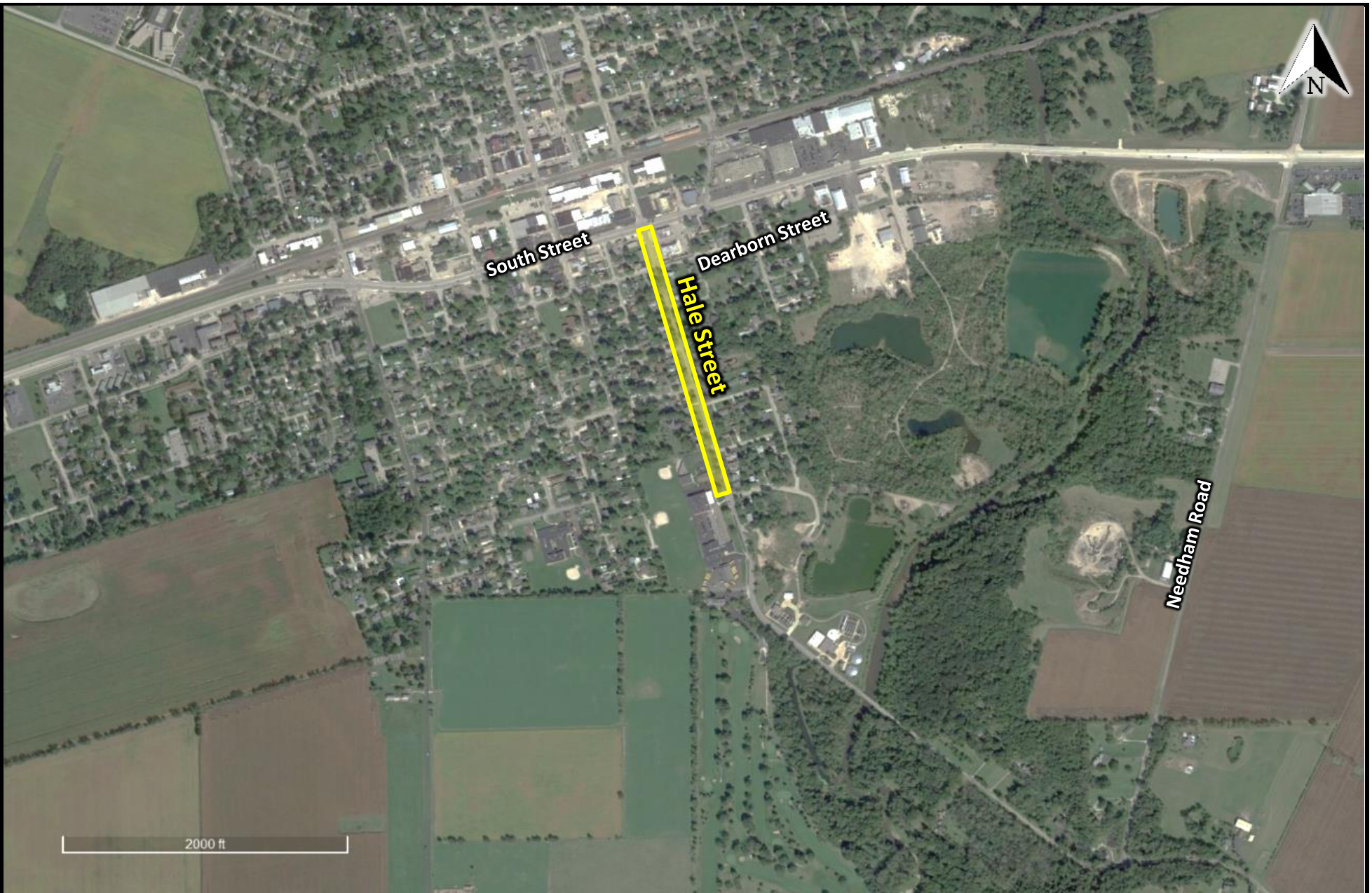

rubino
ENGINEERING INC.

425 Shepard Drive
Elgin, Illinois 60123

Project Name:
Project Location:

Client:
Rubino Project # :

Hale Street Rehabilitation
From US 34 to E Larson Street
Plano, Illinois
HR Green, Inc.
G23.171

**Site
Vicinity
Map**

Appendix B – Proposed Typical Sections

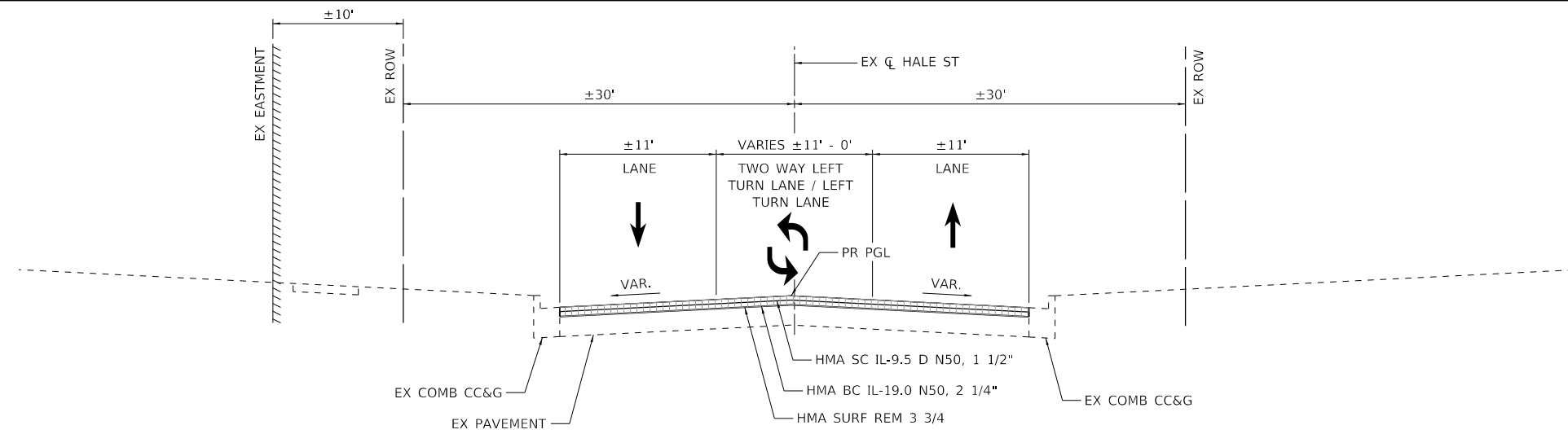

PROPOSED TYPICAL SECTION

STA 100+00 TO STA 107+25
 STA 123+50 TO STA 126+97 (LEFT TURN LANE)

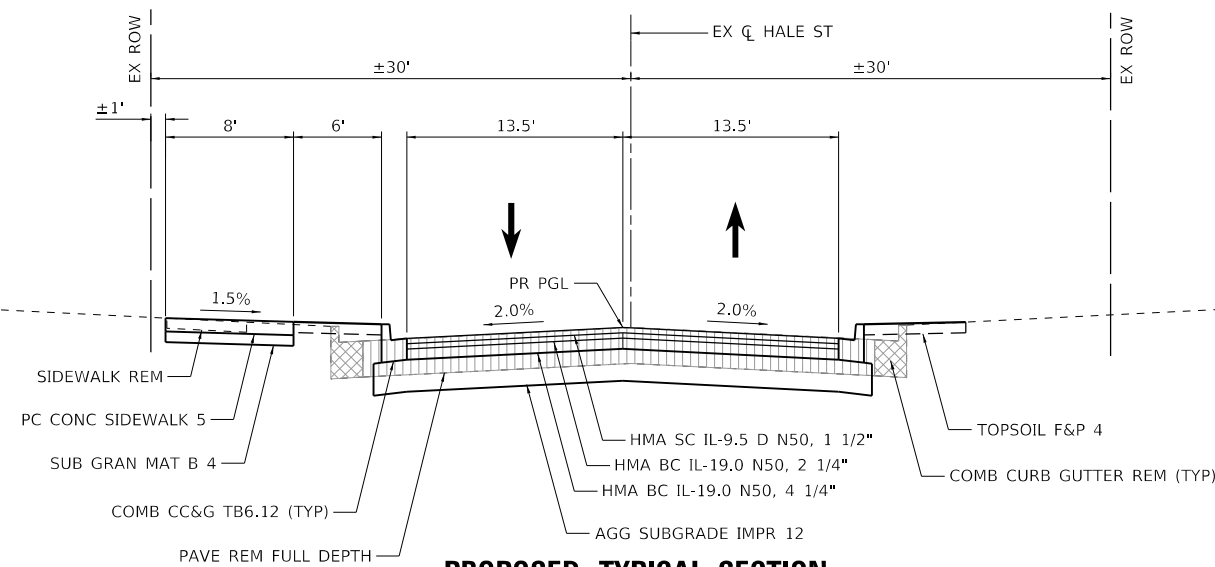

PROPOSED TYPICAL SECTION

STA 107+25 TO STA 111+50

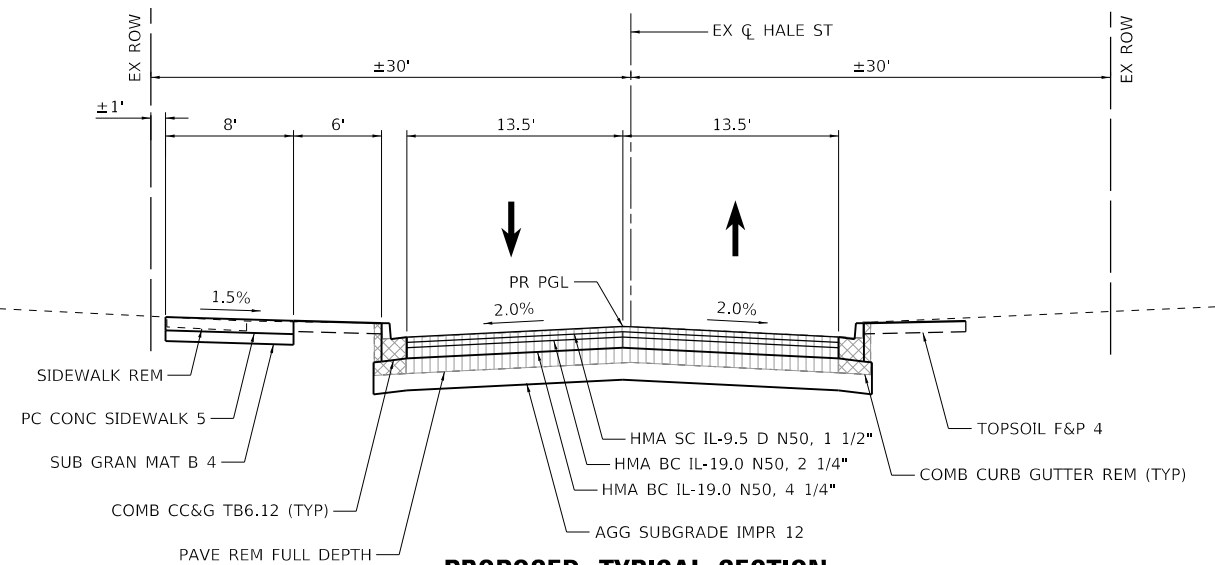

PROPOSED TYPICAL SECTION

STA 111+50 TO STA 123+97

HRG PROJECT NO.: #1939
 HRG PROJ. CONTACT:
 FILE NAME: #1939_S17_Typ-pr0.dgn
 PEN TABLE: #1939.tbl



USER NAME = jroibu	DESIGNED - JMR	REVISED -
	DRAWN - AJM	REVISED -
PLOT SCALE = 12.0000' / in.	CHECKED -	REVISED -
PLOT DATE = 9/18/2024	DATE - 9/17/2024	REVISED -

**STATE OF ILLINOIS
 DEPARTMENT OF TRANSPORTATION**

**PROPOSED TYPICAL SECTIONS
 HALE STREET**

SCALE: N.T.S. SHEET 3 OF 3 SHEETS STA. TO STA.

F.A.U. RTE.	SECTION	COUNTY	TOTAL SHEETS	SHEET NO.
6474	22-00049-00-PV	KENDALL	53	8
CONTRACT NO. 87873				
ILLINOIS FED. AID PROJECT				

Appendix C – Preliminary Plans and Profiles

PLAN	SURVEYED	DATE
	PLOTTED	BY
	ALIGNED	
	CHECKED	
	FILED	
	NO. _____	
	FILE NAME _____	
	TABLE _____	

PROFILE	SURVEYED	DATE
	PLOTTED	BY
	GRADES CHECKED	
	STRUCTURE NOTATIONS CHECKED	
	NO. _____	
	FILE NAME _____	
	TABLE _____	

HRG PROJECT NO. 181939
 HRG PROJ. CONTACT:
 FILE NAME: 181939_571-ppp010.dgn
 PEN TABLE: 181939.tbl

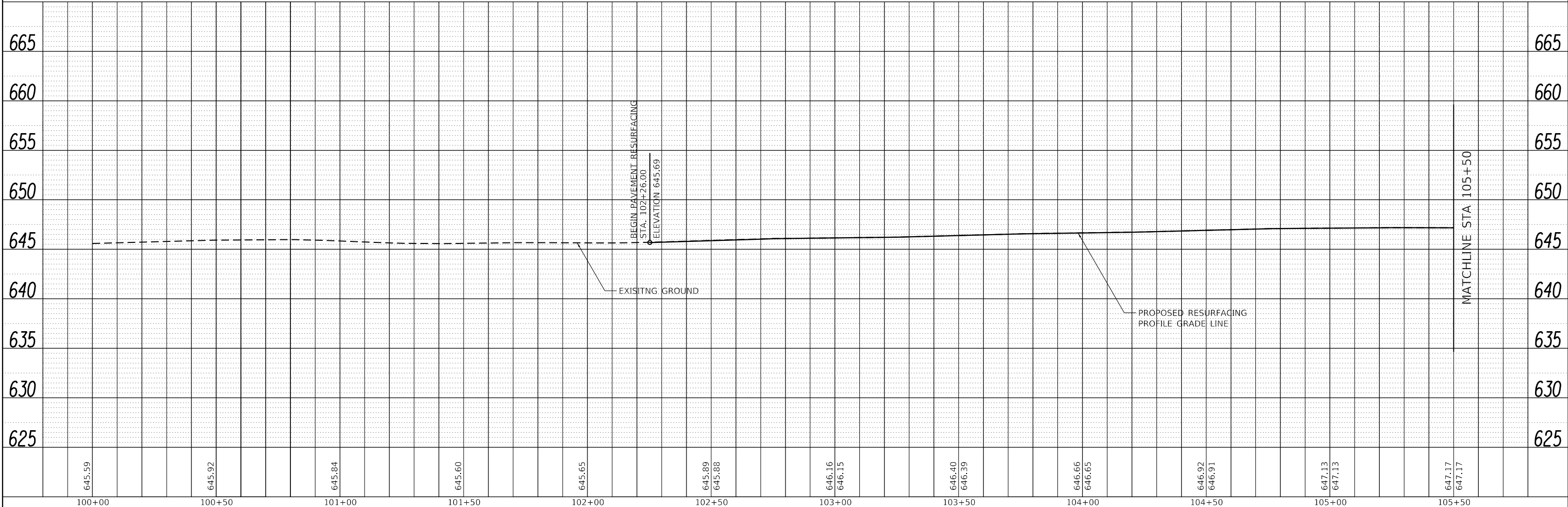
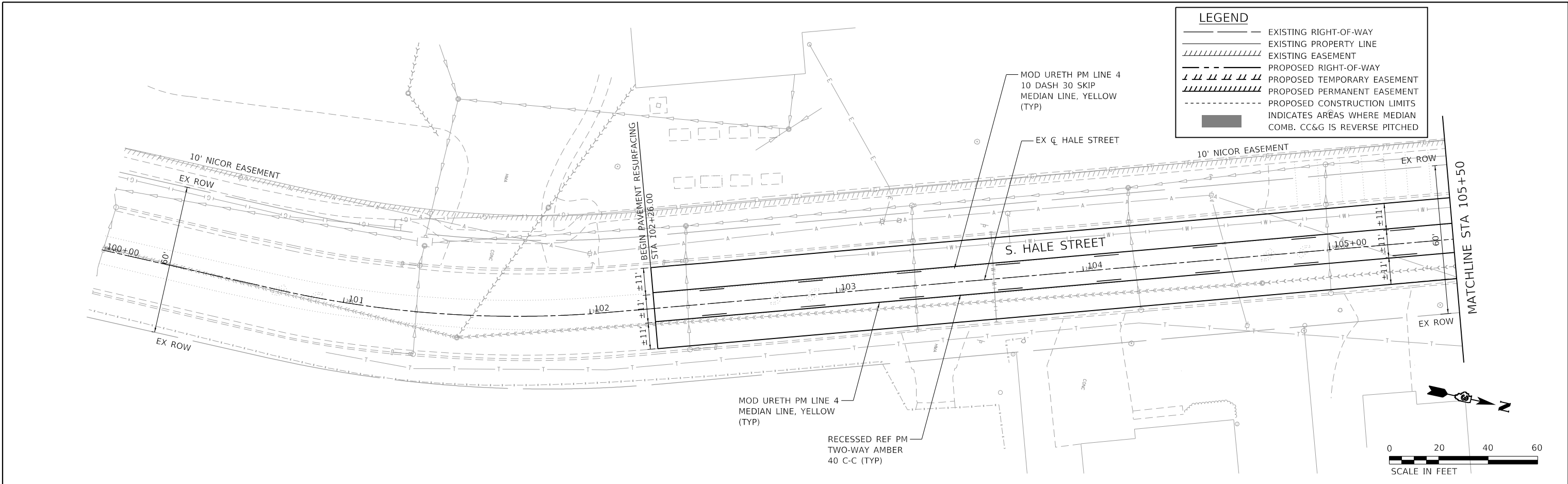

100+00	100+50	101+00	101+50	102+00	102+50	103+00	103+50	104+00	104+50	105+00	105+50
645.59	645.92	645.84	645.60	645.65	645.89 645.88	646.16 646.15	646.40 646.39	646.66 646.65	646.92 646.91	647.13 647.13	647.17 647.17

HRGreen
 HRGreen.com
 Illinois Professional Design Firm
 #184-001322

USER NAME = jroibu	DESIGNED - JMR	REVISED -
	DRAWN - AJM	REVISED -
PLOT SCALE = 40.0000' / in.	CHECKED -	REVISED -
PLOT DATE = 9/18/2024	DATE - 9/17/2024	REVISED -

STATE OF ILLINOIS
DEPARTMENT OF TRANSPORTATION

PLAN AND PROFILE
HALE STREET
 SCALE: 1" = 20' SHEET 1 OF 5 SHEETS STA. 100+00 TO STA. 105+50

F.A.U. RTE. 6474	SECTION 22-00049-00-PV	COUNTY KENDALL	TOTAL SHEETS 53	SHEET NO. 15
CONTRACT NO. 87873			ILLINOIS FED. AID PROJECT	

PLAN	SURVEYED	BY	DATE
	PLOTTED		
	ALIGNED		
	CHECKED		
	FILED		
	NO. _____		
	FILE NAME _____		
	TABLE _____		

PROFILE	SURVEYED	BY	DATE
	PLOTTED		
	GRADES CHECKED		
	STRUCTURE NOTATIONS CHECKED		
	NO. _____		
	FILE NAME _____		
	TABLE _____		

HRG PROJECT NO. 181939
 HRG PROJ. CONTACT:
 FILE NAME: 181939_571-pp02.dgn
 PEN TABLE: pp02.tbl

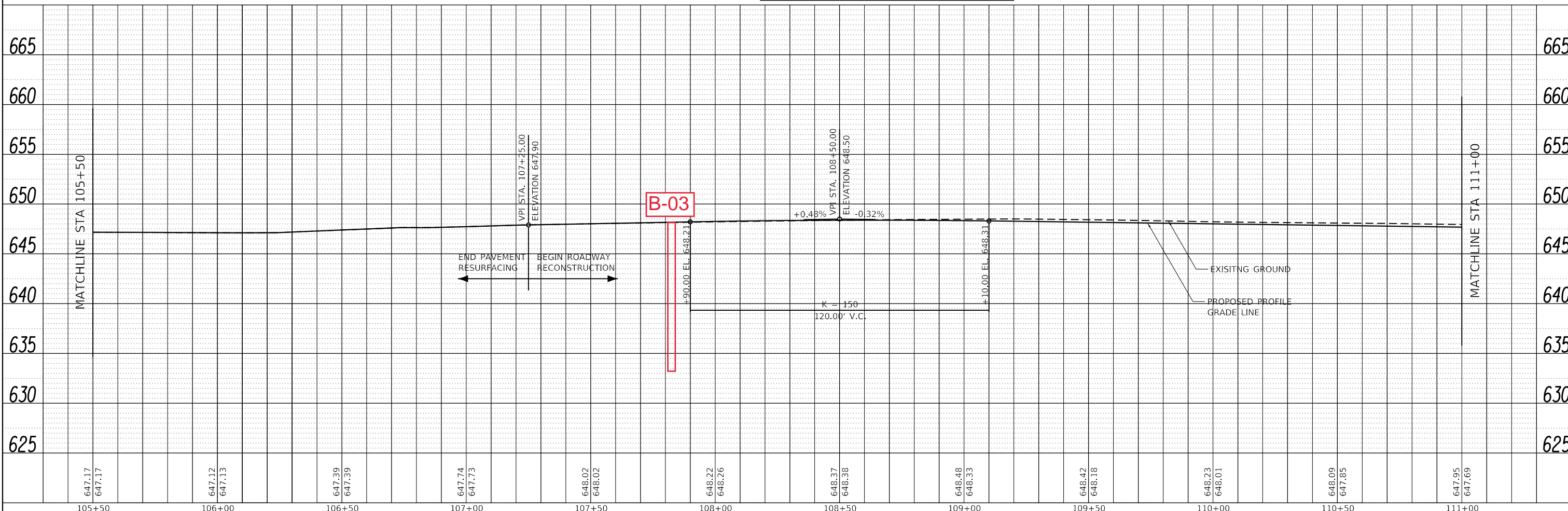
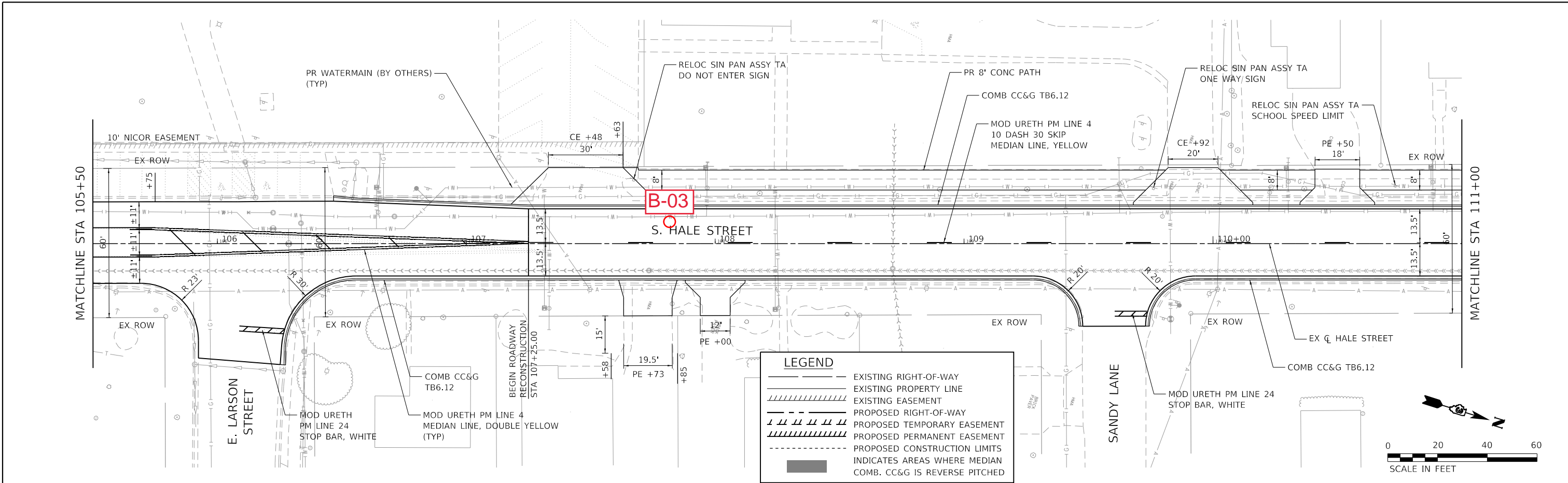

647.17	647.17	647.12	647.13	647.39	647.39	647.74	647.73	648.02	648.02	648.22	648.26	648.37	648.38	648.48	648.33	648.42	648.18	648.23	648.01	648.09	647.85	647.95	647.69
105+50	106+00	106+50	107+00	107+50	108+00	108+50	109+00	109+50	110+00	110+50	111+00												

HRGreen
 HRGreen.com
 Illinois Professional Design Firm
 #184-001322

USER NAME = jroibu	DESIGNED - JMR	REVISED -
	DRAWN - AJM	REVISED -
PLOT SCALE = 40.0000' / in.	CHECKED -	REVISED -
PLOT DATE = 9/18/2024	DATE - 9/17/2024	REVISED -

**STATE OF ILLINOIS
 DEPARTMENT OF TRANSPORTATION**

PLAN AND PROFILE HALE STREET		
SCALE: 1" = 20'	SHEET 2 OF 5 SHEETS	STA. 105+50 TO STA. 111+00

F.A.U. RTE. 6474	SECTION 22-00049-00-PV	COUNTY KENDALL	TOTAL SHEETS 53	SHEET NO. 16
			CONTRACT NO. 87873	
ILLINOIS FED. AID PROJECT				

PLAN	SURVEYED	BY	DATE
	PLOTTED		
	ALIGNED		
	CHECKED		
	FILED		
	CARD FILE NAME		
	NO.		

PROFILE	SURVEYED	BY	DATE
	PLOTTED		
	GRADES CHECKED		
	STRUCTURE NOTATIONS CHECKED		
	NO.		

HRG PROJECT NO. 181939
 HRG PROJ. CONTACT:
 FILE NAME: 181939_181939_S17-pp03.dgn
 PEN TABLE: pp03tbl.tbl

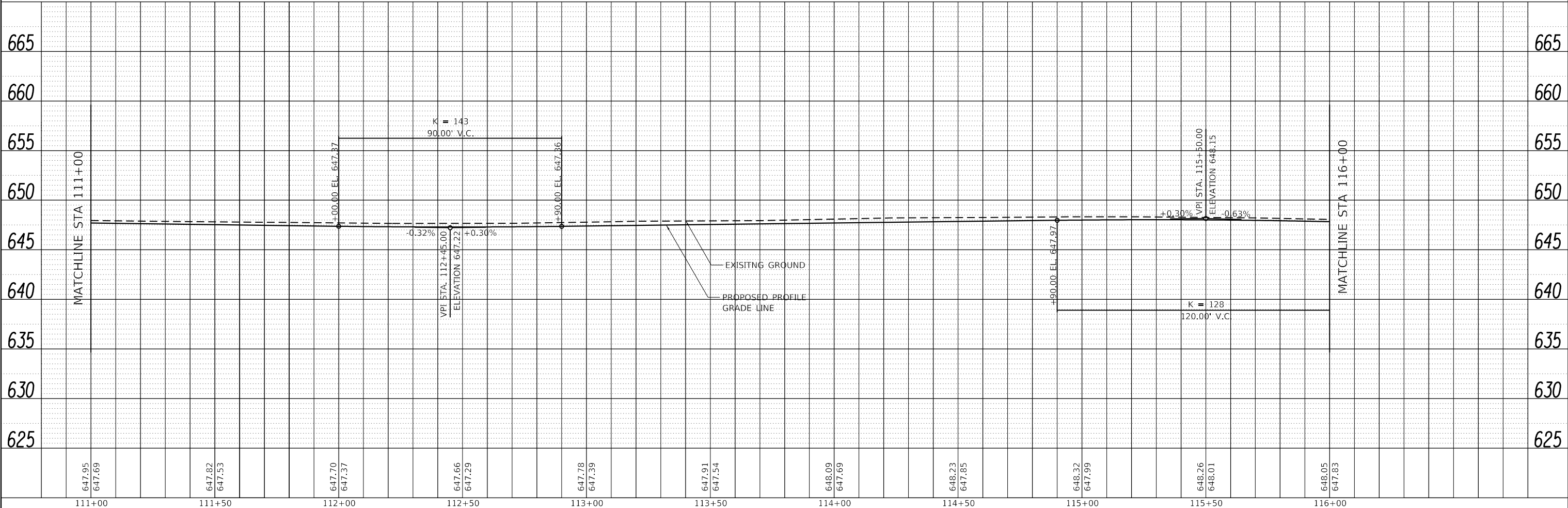
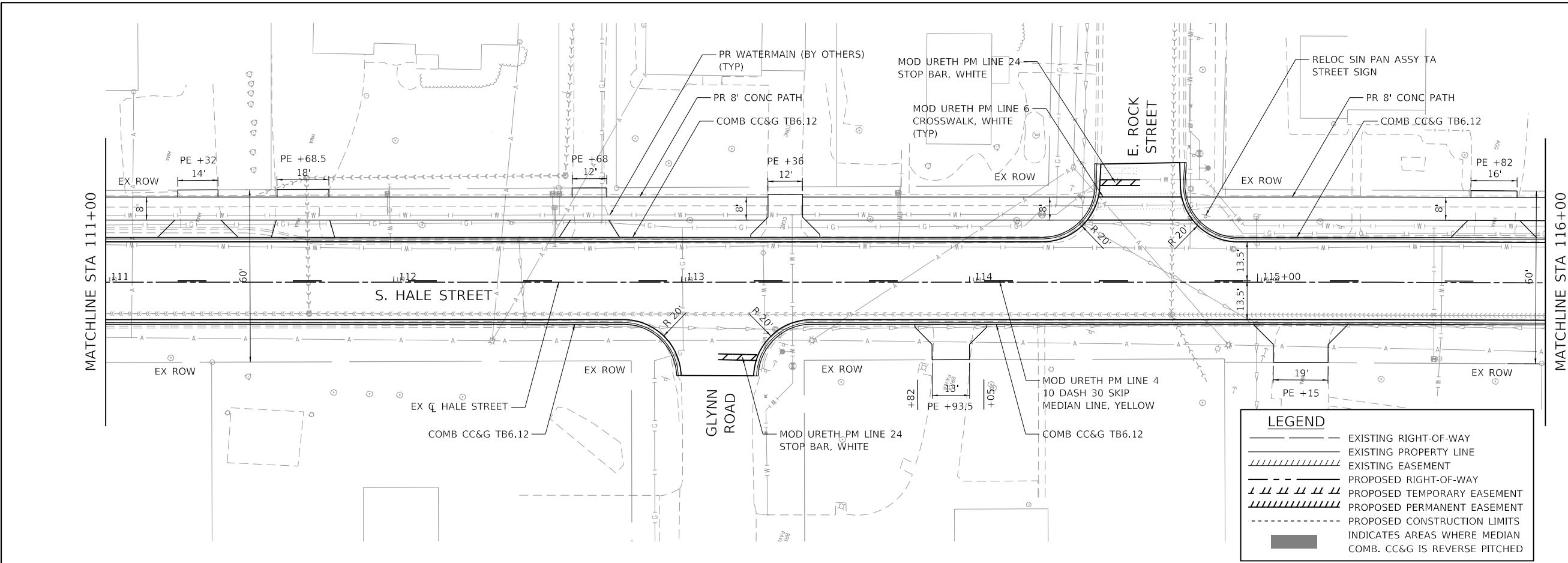

647.95 647.69	647.82 647.53	647.70 647.37	647.66 647.29	647.78 647.39	647.91 647.54	648.09 647.69	648.23 647.85	648.32 647.99	648.26 648.01	648.05 647.83
111+00	111+50	112+00	112+50	113+00	113+50	114+00	114+50	115+00	115+50	116+00

HRGreen
 HRGreen.com
 Illinois Professional Design Firm
 #184-001322

USER NAME = jroibu	DESIGNED - JMR	REVISED -
	DRAWN - AJM	REVISED -
PLOT SCALE = 40.0000' / in.	CHECKED -	REVISED -
PLOT DATE = 9/18/2024	DATE - 9/17/2024	REVISED -

**STATE OF ILLINOIS
 DEPARTMENT OF TRANSPORTATION**

**PLAN AND PROFILE
 HALE STREET**

SCALE: 1" = 20' SHEET 3 OF 5 SHEETS STA. 111+00 TO STA. 116+00

F.A.U. RTE.	SECTION	COUNTY	TOTAL SHEETS	SHEET NO.
6474	22-00049-00-PV	KENDALL	53	17
CONTRACT NO. 87873				
ILLINOIS FED. AID PROJECT				

PLAN	SURVEYED	BY	DATE
	PLOTTED		
	ALIGNED		
	CHECKED		
	FILED		
	NO. _____		
	FILE NAME _____		
	DATE _____		

PROFILE	SURVEYED	BY	DATE
	PLOTTED		
	GRADES CHECKED		
	STRUCTURE NOTATIONS CHECKED		
	NO. _____		
	FILE NAME _____		
	DATE _____		

HRG PROJECT NO. 18/0939
 HRG PROJ. CONTACT:
 FILE NAME: 18/0939_SHT-PROP04.dgn
 PEN TABLE: prop04.tbl

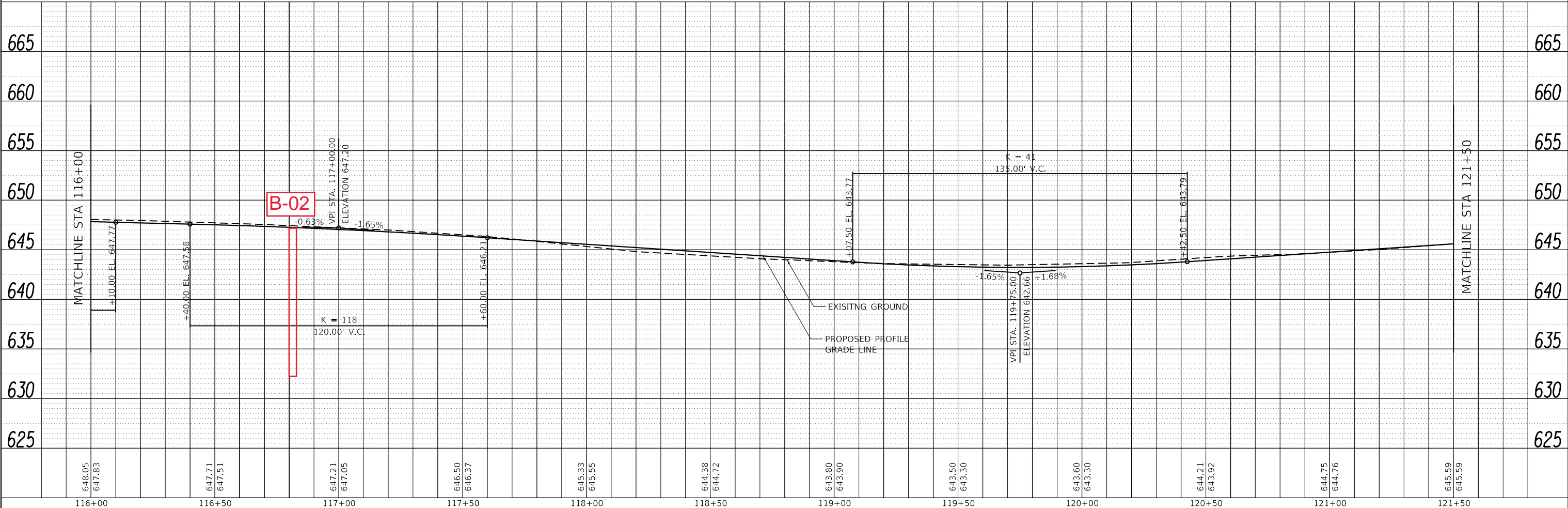
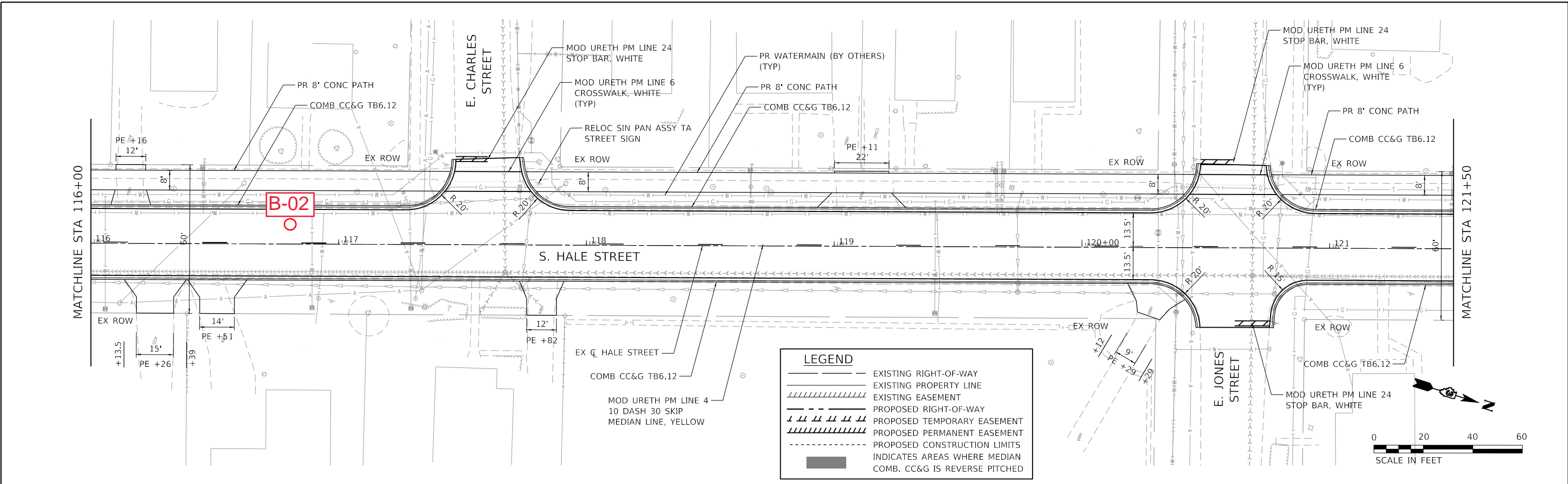

648.05	647.83	647.71	647.51	647.21	647.05	646.50	646.37	645.33	645.55	644.38	644.72	643.80	643.90	643.50	643.30	643.60	643.30	644.21	643.92	644.75	644.76	645.59	645.59
116+00	116+50	117+00	117+50	118+00	118+50	119+00	119+50	120+00	120+50	121+00	121+50												

HRGreen
 HRGreen.com
 Illinois Professional Design Firm
 #184-001322

USER NAME = jroibu	DESIGNED - JMR	REVISED -
	DRAWN - AJM	REVISED -
PLOT SCALE = 40.0000' / in.	CHECKED -	REVISED -
PLOT DATE = 9/18/2024	DATE - 9/17/2024	REVISED -

STATE OF ILLINOIS
DEPARTMENT OF TRANSPORTATION

PLAN AND PROFILE
HALE STREET
 SCALE: 1" = 20' SHEET 4 OF 5 SHEETS STA. 116+00 TO STA. 121+50

F.A.U. RTE. 6474	SECTION 22-00049-00-PV	COUNTY KENDALL	TOTAL SHEETS 53	SHEET NO. 18
CONTRACT NO. 87873			ILLINOIS FED. AID PROJECT	

PLAN	SURVEYED	BY	DATE
	PLOTTED		
	ALIGNED		
	CHECKED		
	FILED		
	NO.		
	NO.		

PROFILE	SURVEYED	BY	DATE
	PLOTTED		
	GRADES		
	CHECKED		
	STRUCTURE		
	NOTATIONS		
	CHKD		
	NO.		

HRG PROJECT NO. 18/0939
 HRG PROJ. CONTACT:
 FILE NAME: 18/0939_571-pp05.dgn
 PEN TABLE: pp05.tbl

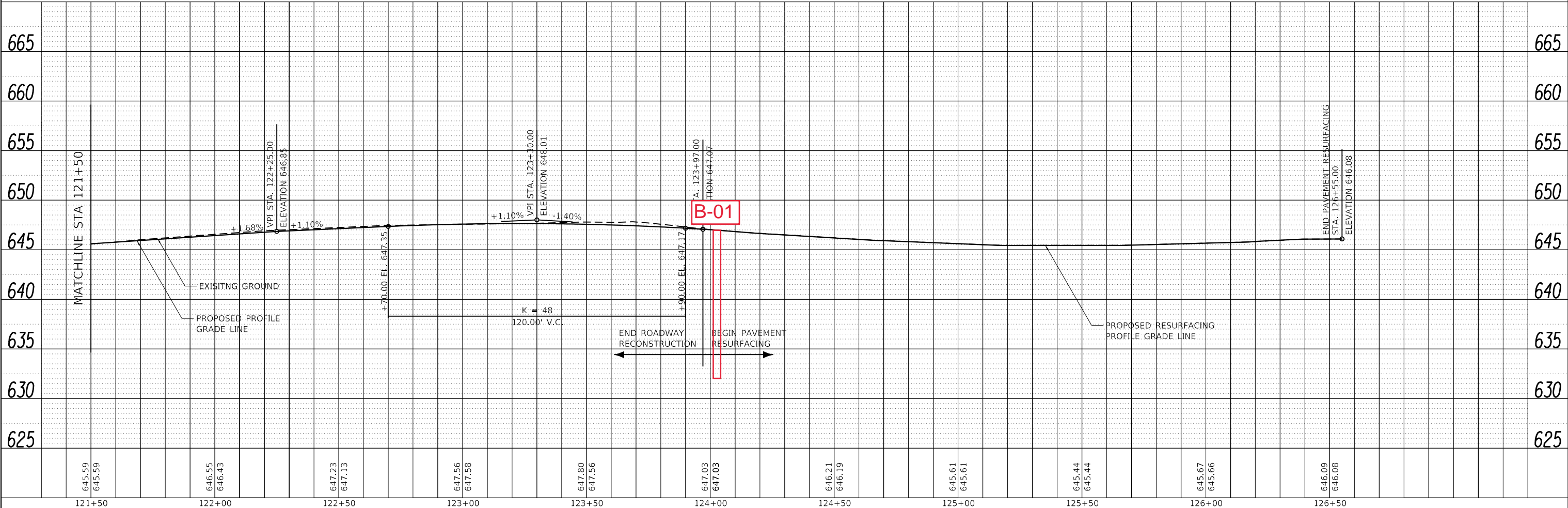
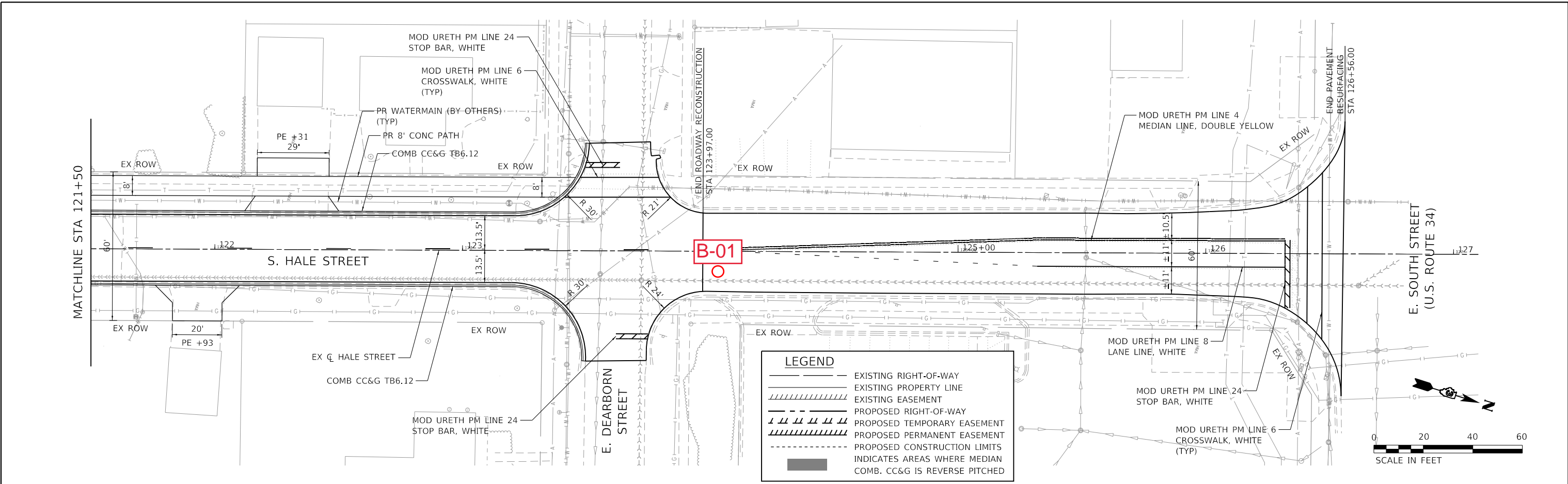

121+50	122+00	122+50	123+00	123+50	124+00	124+50	125+00	125+50	126+00	126+50
645.59 645.59	646.55 646.43	647.23 647.13	647.56 647.58	647.80 647.56	647.03 647.03	646.21 646.19	645.61 645.61	645.44 645.44	645.67 645.66	646.09 646.08

HRGreen
 HRGreen.com
 Micro Professional Design Firm
 #184-001322

USER NAME = jroibu	DESIGNED - JMR	REVISED -
	DRAWN - AJM	REVISED -
PLOT SCALE = 40.0000' / in.	CHECKED -	REVISED -
PLOT DATE = 9/18/2024	DATE - 9/17/2024	REVISED -

**STATE OF ILLINOIS
 DEPARTMENT OF TRANSPORTATION**

**PLAN AND PROFILE
 HALE STREET**

SCALE: 1" = 20' SHEET 5 OF 5 SHEETS STA. 121+50 TO STA. 127+00

F.A.U. RTE.	SECTION	COUNTY	TOTAL SHEETS	SHEET NO.
6474	22-00049-00-PV	KENDALL	53	19
CONTRACT NO. 87873				
ILLINOIS FED. AID PROJECT				

Appendix D – Geology and Pedology Maps

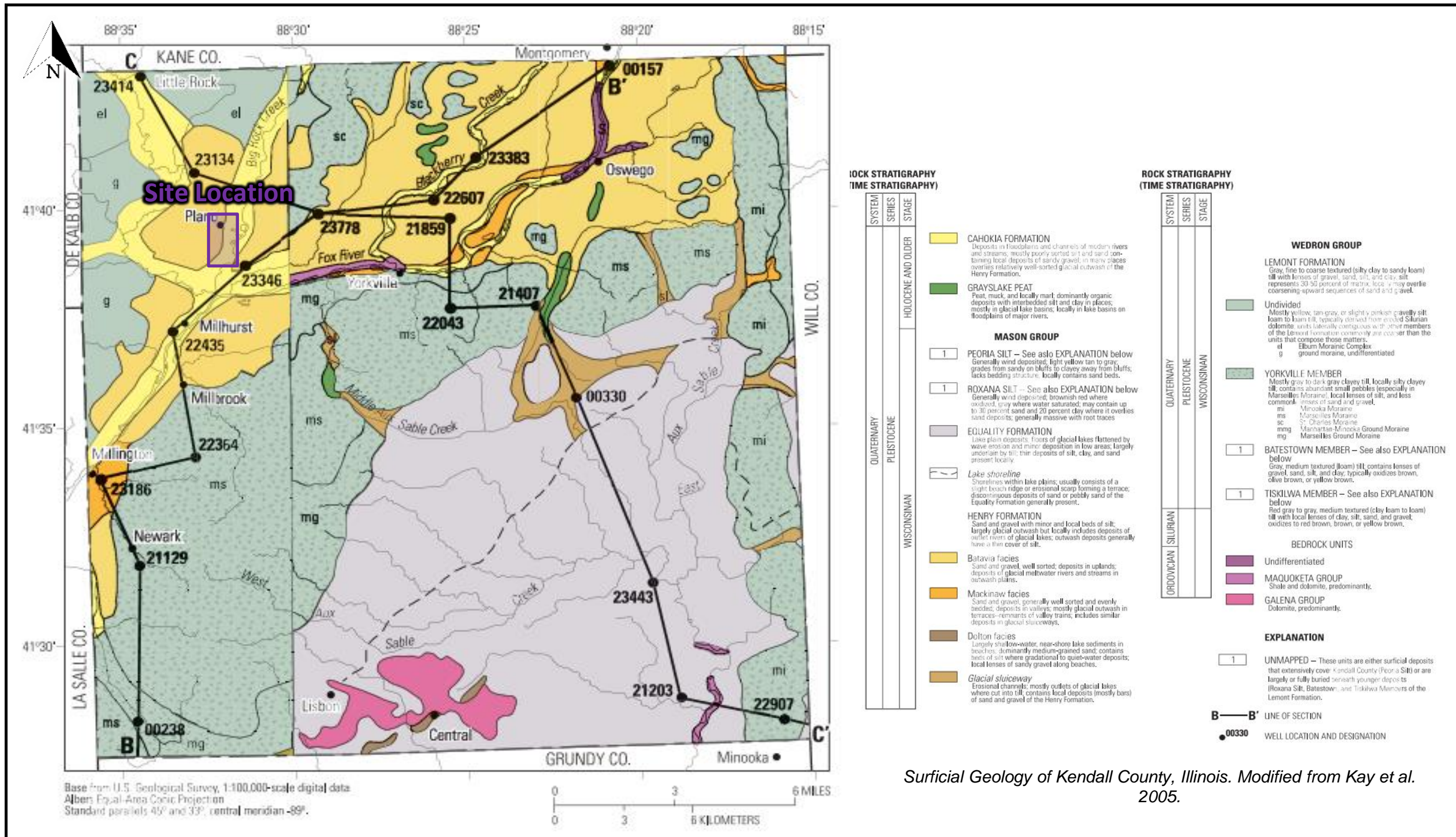

Surficial Geology of Kendall County, Illinois. Modified from Kay et al. 2005.



425 Shepard Drive
Elgin, Illinois 60123

Project Name:
Project Location:
Client:
Rubino Project # :

Hale Street Rehabilitation
From US 34 to E Larson Street
Plano, Illinois
HR Green, Inc.
G23.171

**Surficial
Geology
Map**

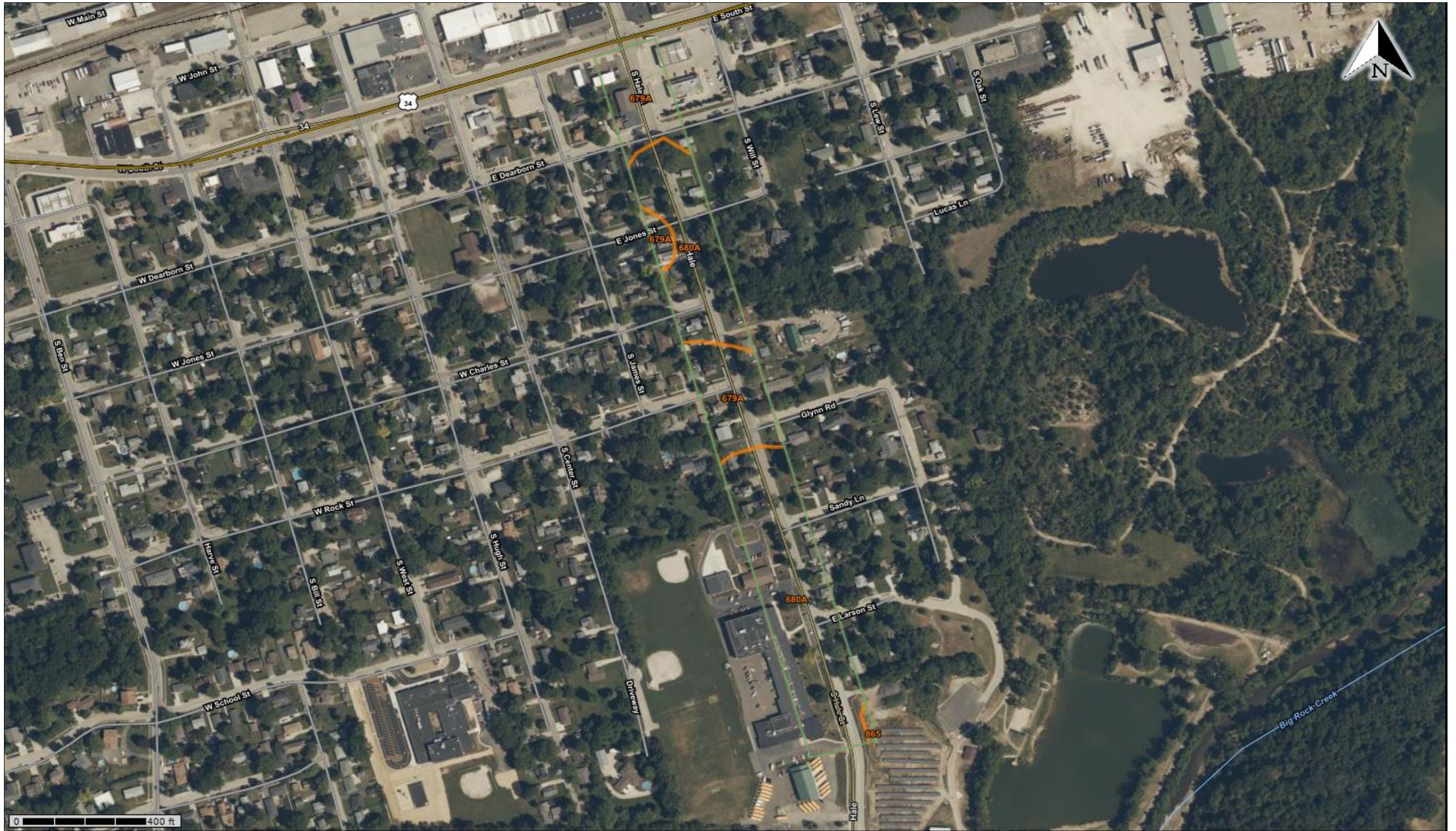

rubino
ENGINEERING INC.

425 Shepard Drive
Elgin, Illinois 60123

Project Name:
Project Location:

Client:
Rubino Project # :

Hale Street Rehabilitation
From US 34 to E Larson Street
Plano, Illinois
HR Green, Inc.
G23.171

USDA / NRCS
Soil Survey
Map

















NRCS Soil Survey Legend G23.171 Hale Street Rehabilitation

Map symbol and soil name	Depth	USDA texture	Classification	Pct Fragments		Sand	Silt	Clay	Moist bulk density	Saturated hydraulic conductivity	Available water capacity	Linear extensibility	Organic matter	Erosion factors			Wind erodibility group	Wind erodibility index	
				AASHTO	>10 inches									3-10 inches	Kw	Kf			T
	In				L-R-H	L-R-H	Pct	Pct	Pct	g/cc	micro m/sec	In/In	Pct	Pct					
679A—Blackberry silt loam, 0 to 2 percent slopes																			
Blackberry	0-11	Silt loam	CL-ML, CL	A-4, A-6	0- 0- 0	0- 0- 0	0- 5- 10	63-73- 82	18-22- 27	1.10-1.30	4.23-14.11	0.22-0.24	0.0-2.9	3.0-5.0	0.32	0.32	5	6	48
	11-47	Silty clay loam, silt loam	CL	A-4, A-6, A-7-6	0- 0- 0		0- 5- 10	55-65- 75	25-30- 35	1.20-1.40	4.23-14.11	0.18-0.20	3.0-5.9	0.2-1.0	0.43	0.43			
	47-62	Stratified loam to silt loam	CL-ML, CL, ML	A-4	0- 0- 0	0- 0- 0	20-38- 50	35-42- 55	15-20- 25	1.40-1.60	4.23-14.11	0.11-0.22	0.0-2.9	0.1-0.5	0.43	0.43			
	62-70	Stratified silt loam to loam to sandy loam	CL-ML, SC-SM, CL, ML, SC, SM	A-4	0- 0- 0	0- 0- 0	30-40- 60	20-44- 55	5-16-20	1.50-1.70	4.23-14.11	0.13-0.17	0.0-2.9	0.1-0.5	0.43	0.43			
680A—Campton silt loam, 0 to 2 percent slopes																			
Campton	0-6	Silt loam	CL-ML, CL	A-4, A-6	0- 0- 0	0- 0- 0	0- 9- 10	63-67- 80	20-24- 27	1.15-1.30	4.23-14.11	0.22-0.24	0.0-2.9	1.0-3.0	0.43	0.43	5	6	48
	6-50	Silty clay loam, silt loam	CL	A-6	0- 0- 0	0- 0- 0	0- 7- 10	55-63- 75	25-30- 35	1.30-1.50	4.23-14.11	0.18-0.20	3.0-5.9	0.0-1.0	0.43	0.43			
	50-61	Sandy loam, silt loam, clay loam, loam	CL, SC	A-2-4, A-2-6, A-4, A-6	0- 0- 0	0- 0- 0	20-43- 65	5-35- 65	15-23- 30	1.30-1.50	4.23-14.11	0.11-0.16	3.0-5.9	0.0-0.5	0.49	0.49			
	61-73	Stratified loamy sand to gravelly loam	CL-ML, SC-SM, CL, SC	A-2-6, A-4, A-6	0- 0- 0	0- 3- 4	25-53- 80	10-33- 50	2/15/2025	1.55-1.75	4.23-42.34	0.11-0.16	0.0-2.9	0.0-0.5	0.55	0.55			

Appendix E – Pavement Core Summary Table

Cores were taken in the pavement of Hale Street in Plano, Illinois. The table below summarizes the thicknesses observed in the field and laboratory.

<p style="text-align: center;">C-01 (Hale Street)</p>	<p style="text-align: center;">C-02 (Hale Street)</p>	<p style="text-align: center;">C-03 (Hale Street)</p>
		
<p style="text-align: center;">Picture Taken Facing North/Northwest</p>	<p style="text-align: center;">Picture Taken Facing South/Southeast</p>	<p style="text-align: center;">Picture Taken Facing South/Southeast</p>
		
<p style="text-align: center;"><u>Total Thickness = 8 ¼ inches</u></p> <ul style="list-style-type: none">  HMA Surface₁ = 2 ½ in. <li style="padding-left: 20px;">Surface₁ to Binder₁ Weathering & Deterioration  HMA Surface₂ = ¾ in.  HMA Binder₁ = 5 in. <li style="padding-left: 20px;">Binder₁ NOT FULLY RECOVERED due to Weathering & Deterioration <li style="background-color: #cccccc; padding-left: 20px;">Subbase Stone = 6 inches 	<p style="text-align: center;"><u>Total Thickness = 7 inches</u></p> <ul style="list-style-type: none">  HMA Surface₁ = 2 in.  HMA Surface₂ = 2 in.  HMA Surface₃ = 3 in. <li style="background-color: #cccccc; padding-left: 20px;">Subbase Stone = 7 inches 	<p style="text-align: center;"><u>Total Thickness = 4 ½ inches</u></p> <ul style="list-style-type: none">  HMA Surface₁ = 1 ½ in.  HMA Binder₁ = 3 in. <li style="background-color: #cccccc; padding-left: 20px;">Subbase Stone = 8 ½ inches

The referenced thicknesses are considered approximate. Commentary provided by Rubino is based on our observation in the laboratory; **Crack** = vertical through cross section; **Weathering** = rounded edges & degradation of asphalt and **Deterioration** = horizontal crack. Pavement and subbase type and thickness may vary between core locations. Any comments on the condition of the material are considered our opinion and should be verified by the design engineer.



Appendix F – Boring Logs and Subsurface Profile

Rubino Job No.: G23.171
 Project: Hale Street Rehabilitation
 Location: From US 34 to E Larson Street
 City, State: Plano, Illinois
 Client: HR Green, Inc.

Drilling Method: 2 ¼ Hollow Stem Auger
 Sampling Method: Split Spoon
 Hammer Type: Automatic
 Boring Location: NB lane of Hale Street
 2 feet W from edge of pavement

WATER LEVELS***	
▽ While Drilling	N/A
▼ Upon Completion	N/A
▽ Delay	N/A

Elevation (feet)	Depth, (feet)	Graphic Log	Sample Type	Sample No.	Recovery (inches)	Station: 124+04.16 Offset: 9.8821	MATERIAL DESCRIPTION	Classification	SPT Blows per 6-inch	STANDARD PENETRATION TEST DATA		Additional Remarks
										Moisture, %	Moisture, %	
	0					Surface Elev.: 646.97 ft						
						Approximately 8 ¼ inches of ASPHALT						
						Approximately 6 inches of SUBBASE STONE						
645				1	8	Very stiff, dark gray and gray SILTY CLAY, with roots, trace sand and gravel <i>Possible Fill</i> <i>Large tree roots observed in 1 ft & 3 ½ ft spoon samples</i>	CL	3-2-5 N=7	29	×		Qp=3.5 tsf 3% Organic Content
				2	2		CL	3-2-4 N=6	28	×		4% Organic Content
640				3	10	Medium stiff to stiff, brown SILTY CLAY LOAM, trace gravel	CL	3-3-3 N=6	13	×		Qp=0.8 tsf
				4	16		CL	1-2-3 N=5	12	×		Qp=1.3 tsf
635				5	15	Medium dense, brown SAND, trace gravel	SP	4-6-7 N=13	4	×		
				6	16		SP	8-11-15 N=26	8	×		
	15					End of boring at approximately 15 feet below existing grade.						

Completion Depth: 15.0 ft	Sample Types:	Pressuremeter	Latitude: 41.6607858
Date Boring Started: 12/7/23	Auger Cutting	Shelby Tube	Longitude: -88.5341500
Date Boring Completed: 12/7/23	Split-Spoon	Grab Sample	Drill Rig: Geoprobe 7822DT
Logged By: P.P.	Rock Core	No Recovery	Remarks: Hole collapse at ~11 feet BEG after
Drilling Contractor: Rubino Engineering, Inc.			Log Entry: J. Ignarski
			Checked By: J. Ignarski

The stratification lines represent approximate boundaries. The transition may be gradual.
 ***Please reference the geotechnical report text for specific groundwater / dewatering recommendations.

Rubino Job No.: G23.171
 Project: Hale Street Rehabilitation
 Location: From US 34 to E Larson Street
 City, State: Plano, Illinois
 Client: HR Green, Inc.

Drilling Method: 2 ¼ Hollow Stem Auger
 Sampling Method: Split Spoon
 Hammer Type: Automatic
 Boring Location: SB lane of Hale Street
 5 feet E from edge of pavement

WATER LEVELS***	
▽ While Drilling	N/A
▼ Upon Completion	N/A
▽ Delay	N/A

Elevation (feet)	Depth, (feet)	Graphic Log	Sample Type	Sample No.	Recovery (inches)	Station: 116+80.91 Offset: -11.1208	MATERIAL DESCRIPTION	Classification	SPT Blows per 6-inch	Moisture, %	STANDARD PENETRATION TEST DATA		Additional Remarks
											Moisture	Strength	
	0						Surface Elev.: 647.00 ft						
							Approximately 7 inches of ASPHALT						
							Approximately 7 inches of SUBBASE STONE						
645				1	8		Very stiff to hard, brown SILTY CLAY, trace sand and gravel	CL	3-4-5 N=9	26	⊗	Qp=3.5 tsf 3% Organic Content	
				2	10			CL	2-5-6 N=11	23	⊗	Qp=4.0 tsf	
640				3	14		Very stiff to hard, brown SILTY CLAY LOAM, trace gravel	CL	5-11-12 N=23	12	⊗	Qp=3.3 tsf	
				4	13			CL	3-6-7 N=13	12	⊗	Qp=4.5 tsf	
635				5	17		Hard, brown SILT, trace sand and gravel	ML	7-9-14 N=23	17	⊗	Qp=4.5 tsf	
				6	18		Hard, brown SILTY CLAY, trace sand and gravel	CL	11-13-15 N=28	11	⊗	Qp=4.5 tsf	
15							End of boring at approximately 15 feet below existing grade.						

Completion Depth: 15.0 ft	Sample Types:	Pressuremeter	Latitude: 41.6588734
Date Boring Started: 12/7/23	Auger Cutting	Shelby Tube	Longitude: -88.5334372
Date Boring Completed: 12/7/23	Split-Spoon	Grab Sample	Drill Rig: Geoprobe 7822DT
Logged By: P.P.	Rock Core	No Recovery	Remarks: Hole collapse at ~14 feet BEG after
Drilling Contractor: Rubino Engineering, Inc.			Log Entry: J. Ignarski
			Checked By: J. Ignarski

The stratification lines represent approximate boundaries. The transition may be gradual.
 ***Please reference the geotechnical report text for specific groundwater / dewatering recommendations.

Rubino Job No.: G23.171
 Project: Hale Street Rehabilitation
 Location: From US 34 to E Larson Street
 City, State: Plano, Illinois
 Client: HR Green, Inc.

Drilling Method: 2 ¼ Hollow Stem Auger
 Sampling Method: Split Spoon
 Hammer Type: Automatic
 Boring Location: SB lane of Hale Street
 5 feet E from edge of pavement

WATER LEVELS***	
▽ While Drilling	N/A
▼ Upon Completion	N/A
▽ Delay	N/A

Elevation (feet)	Depth, (feet)	Graphic Log	Sample Type	Sample No.	Recovery (inches)	MATERIAL DESCRIPTION	Classification	SPT Blows per 6-inch	Moisture, %	STANDARD PENETRATION TEST DATA		Additional Remarks
										Moisture	Strength	
						Station: 107+81.68 Offset: -15.5781						
						Surface Elev.: 647.95 ft						
						Approximately 4½ inches of ASPHALT						
						Approximately 8½ inches of SUBBASE STONE						
				1	12	Brown HIGH PLASTICITY SILTY CLAY, trace sand and gravel	CH	0-2-2 N=4	26	26	Qp=2.8 tsf LL = 59 PL = 26 3% Organic Content	
645				2	6		CH	0-1-1 N=2	22	22	Qp=1.3 tsf	
	5											
				3	1	Stiff, brown SILTY CLAY, trace sand and gravel Low Recovery. Soils classified from auger cuttings.	CL	3-3-5 N=8	17	17		
640												
				4	10	Medium dense, brown SAND, some gravel Possible cobbles/boulders encountered	SW	11-12-11 N=23	8	8		
	10											
				5	16	Dense, brown SAND, trace gravel	SP	11-21-22 N=43	3	3		
635												
				6	14		SP	13-14-33 N=47	3	3		
	15					End of boring at approximately 15 feet below existing grade.						

Completion Depth: 15.0 ft	Sample Types:	Pressuremeter	Latitude: 41.6565157
Date Boring Started: 12/7/23	Auger Cutting	Shelby Tube	Longitude: -88.5324645
Date Boring Completed: 12/7/23	Split-Spoon	Grab Sample	Drill Rig: Geoprobe 7822DT
Logged By: P.P.	Rock Core	No Recovery	Remarks: Hole collapse at ~12 feet BEG after
Drilling Contractor: Rubino Engineering, Inc.			Log Entry: J. Ignarski
			Checked By: J. Ignarski

The stratification lines represent approximate boundaries. The transition may be gradual.
 ***Please reference the geotechnical report text for specific groundwater / dewatering recommendations.

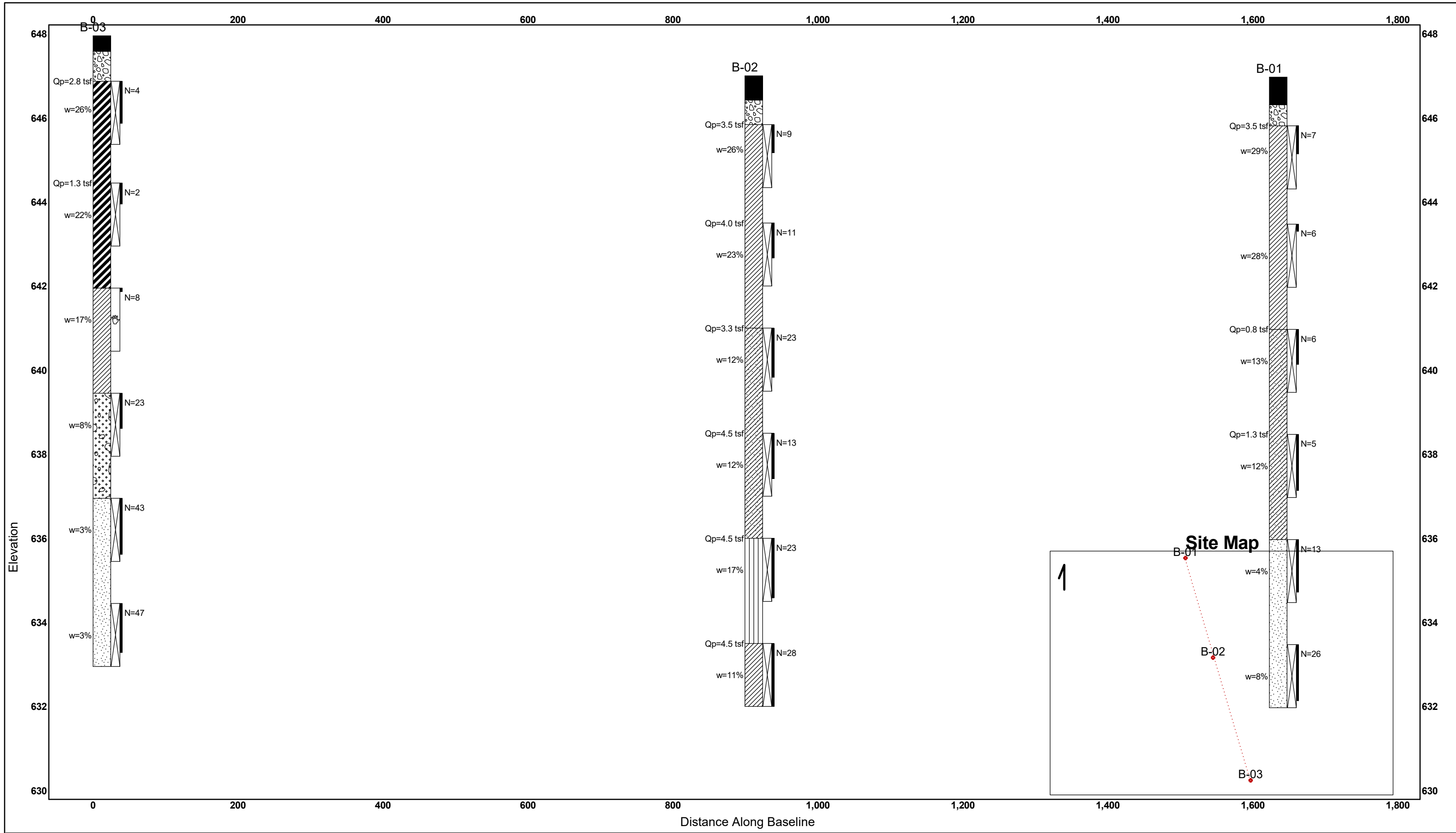

Rubino Engineering, Inc.
 425 Shepard Drive
 Elgin, IL 60123
 Telephone: 847-931-1555
 Fax: 847-931-1560

Soil Profile

- Sample Types:**
- Auger Cuttings
 - Split Spoon
 - Shelby Tube
 - Pressuremeter

Rubino Job No.: G23.171
Project: Hale Street Rehabilitation
Location: From US 34 to E Larson Street
City, State: Plano, Illinois
Client: HR Green, Inc.

Appendix G – Laboratory Test Results

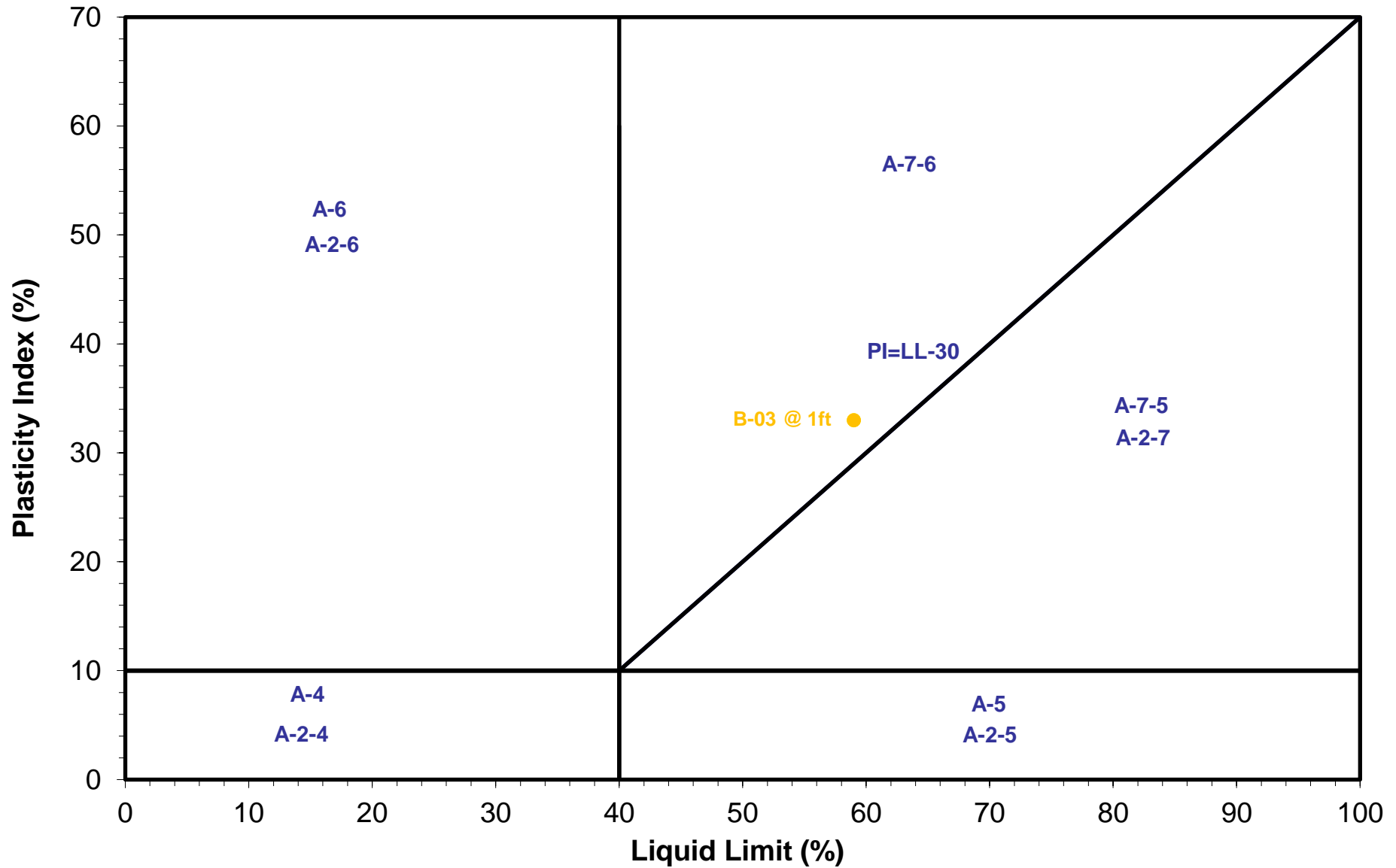

Boring #	B-03 @ 1ft						Project: Hale Street Rehabilitation Location: Plano, Illinois Client: HR Green, Inc. Project #: G23.171
LL	59						
PL	26						
PI	33						

Appendix H – Report Limitations

Subsurface Conditions:

The subsurface description is of a generalized nature to highlight the major subsurface stratification features and material characteristics. The boring logs included in the appendix should be reviewed for specific information at individual boring locations. These records include soil descriptions, stratifications, penetration resistances, locations of the samples and laboratory test data as well as water level information. The stratifications shown on the boring logs represent the conditions only at the actual boring locations. Variations may occur and should be expected between boring locations. The stratifications represent the approximate boundary between subsurface materials and the actual transition between layers may be gradual.

Geotechnical Risk:

The concept of risk is an important aspect of the geotechnical evaluation. The primary reason for this is that the analytical methods used to develop geotechnical recommendations do not comprise an exact science. The analytical tools that geotechnical engineers use are generally empirical and must be used in conjunction with engineering judgment and experience. Therefore, the solutions and recommendations presented in the geotechnical evaluation should not be considered risk-free, and more importantly, are not a guarantee that the interaction between the soils and the proposed structure will perform as planned. The engineering recommendations, presented in the preceding section, constitute Rubino's professional estimate of the necessary measures for the proposed structure to perform according to the proposed design based on the information generated and reference during this evaluation, and Rubino's experience in working with these conditions.

Warranty:

The geotechnical engineer warrants that the findings, recommendations, specifications, or professional advice contained herein have been made in accordance with generally accepted professional geotechnical engineering practices in the local area. No other warranties are implied or expressed.

Federal Excavation Regulations:

In Federal Register, Volume 54, No. 209 (October 1989), the United States Department of Labor, Occupational Safety and Health Administration (OSHA) amended its "Construction Standards for Excavations, 29 CFR, part 1926, Subpart P". This document was issued to better ensure the safety of workmen entering trenches or excavations. This federal regulation mandates that all excavations, whether they be utility trenches, basement excavation or footing excavations, be constructed in accordance with the new OSHA guidelines. It is our understanding that these regulations are being strictly enforced and if they are not closely followed, the owner and the contractor could be liable for substantial penalties.

The contractor is solely responsible for designing and constructing stable, temporary excavations and should shore, slope, or bench the sides of the excavations as required to maintain stability of both the excavation sides and bottom. The contractor's "responsible person," as defined in 29 CFR Part 1926, should evaluate the soil exposed in the excavations as part of the contractor's safety procedures. In no case should slope height, slope inclination, or excavation depth, including utility trench excavation depth, exceed those specified in local, state, and federal safety regulations. Rubino is providing this information solely as a service to our client. Rubino is not assuming responsibility for construction site safety or the contractor's activities; such responsibility is not being implied and should not be inferred.