

F.A. RTE.	SECTION	COUNTY	TOTAL SHEETS	SHEET NO.
VAR.	2007-064I	McHENRY	7	4
STA.	TO STA.			
FED. ROAD DIST. NO.	ILLINOIS	FED. AID PROJECT		

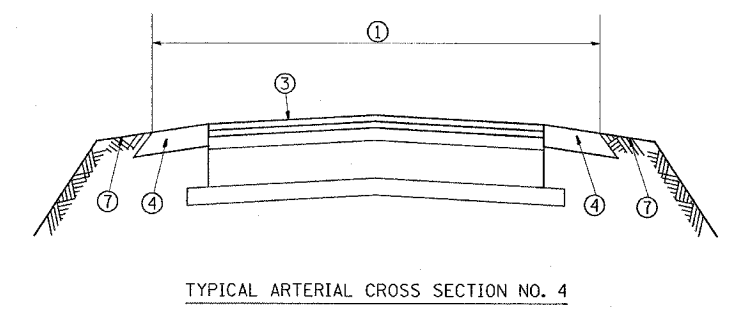
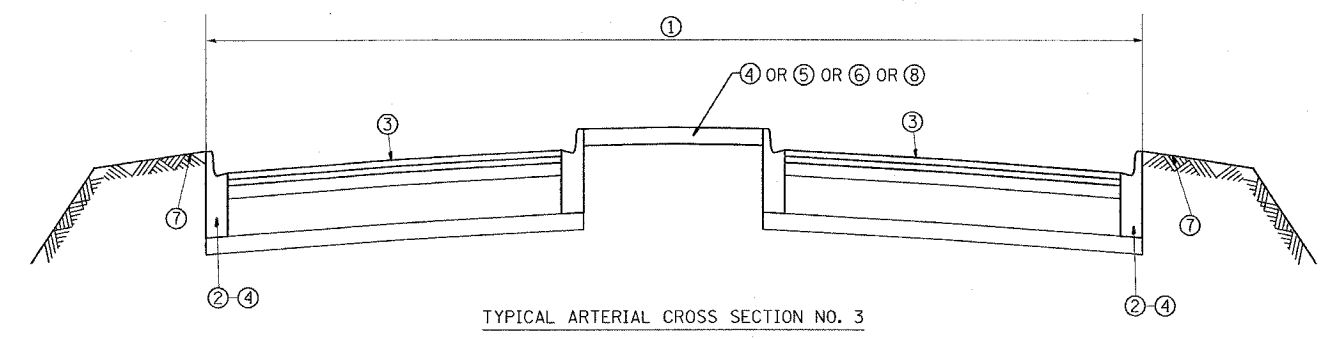
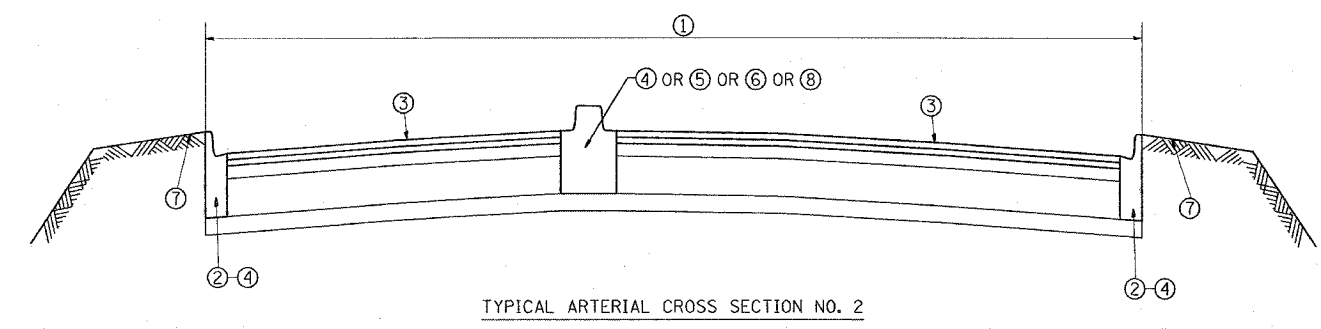
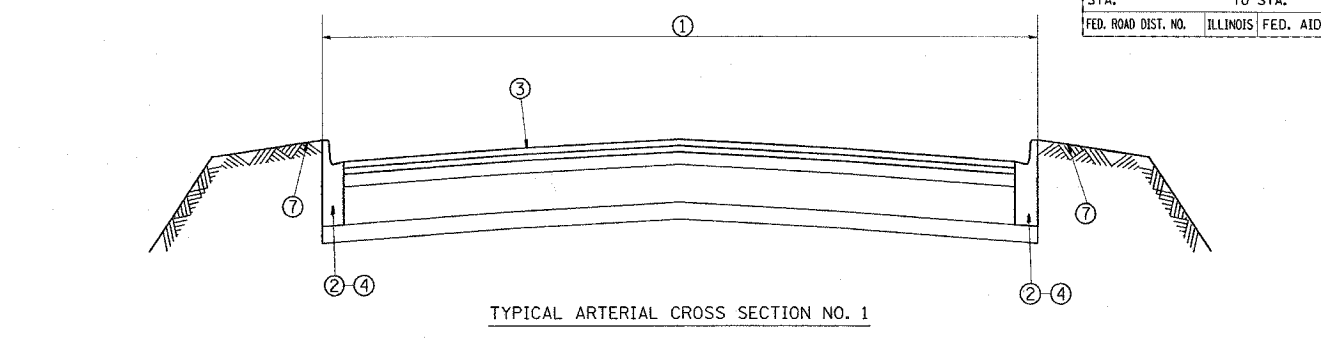
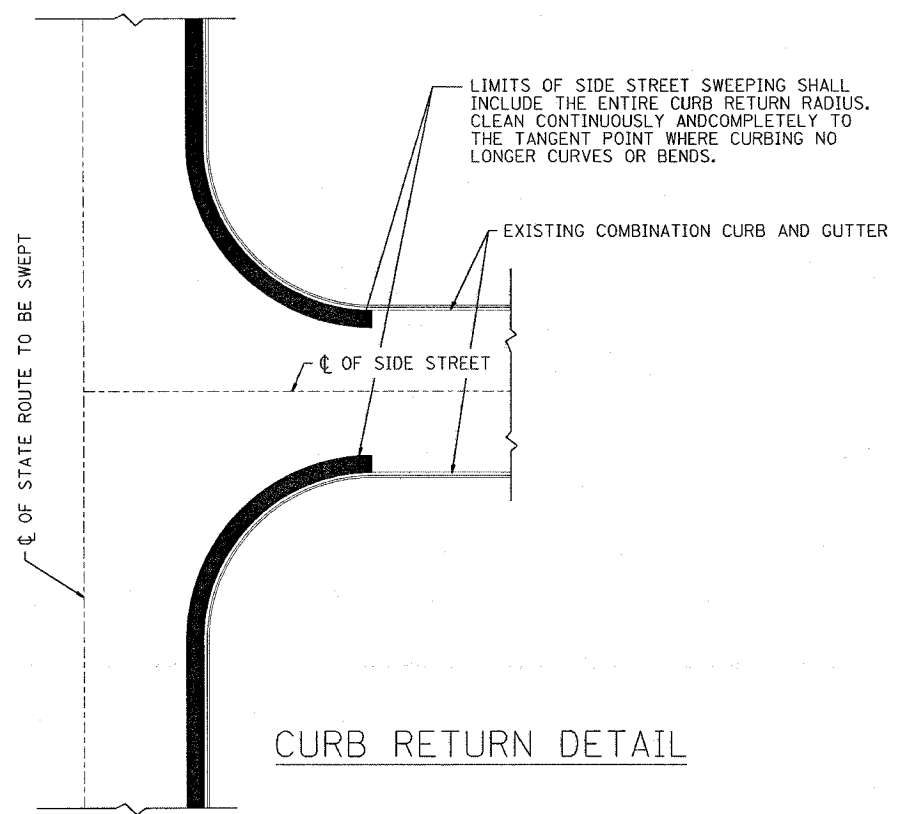

- LEGEND**
- ① AREA OF ROADWAY CLEANING AND RUBBISH REMOVAL
 - ② CURB AND GUTTER
 - ③ TRAVELED ROADWAY
 - ④ STABILIZED SHOULDER OR MEDIAN
 - ⑤ STEEL PLATE GUARD
 - ⑥ CONCRETE BARRIER
 - ⑦ NON STABILIZED AREA
 - ⑧ RAISED CONCRETE MEDIAN

NOTE:
SLOPE WALLS UNDER BRIDGES ARE NOT INCLUDED IN AREAS TO BE CLEANED.

REVISIONS	
NAME	DATE

ILLINOIS DEPARTMENT OF TRANSPORTATION
ARTERIAL HIGHWAY
CLEANING (SWEEPING)

**TYPICAL
ARTERIAL CROSS SECTIONS
AND CURB RETURN DETAIL**

SCALE: VERT. _____
HORIZ. _____

DATE _____ DRAWN BY _____
CHECKED BY _____