

F.A.P. RTE.	SECTION	COUNTY	TOTAL SHEETS	SHEET NO.
808		DOUGLAS	42	31
STA.		TO STA.		
FED. ROAD DIST. NO.	ILLINOIS	FED. AID PROJECT		

(12,Y-15D)10RS-2

TYPICAL DETAIL OF RURAL PRIVATE AND COMMERCIAL ENTRANCES

(ENTRANCE WITHOUT EXISTING APRON)

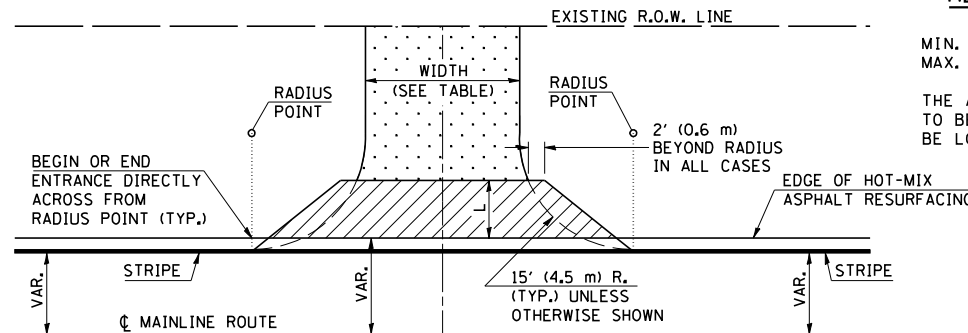

ALLOWABLE ENTRANCE WIDTHS

	PRIVATE	COMMERCIAL
MIN.	12' (3.6 m)	24' (7.3 m)
MAX.	24' (7.3 m)	35' (10.7 m)

THE ALLOWABLE ENTRANCE WIDTHS SHALL BE INTERPRETED TO BE THE WIDTHS AT THE COMPLETED RADIUS, WHICH MAY BE LOCATED BEHIND THE EXISTING R.O.W. LINE.

PLAN

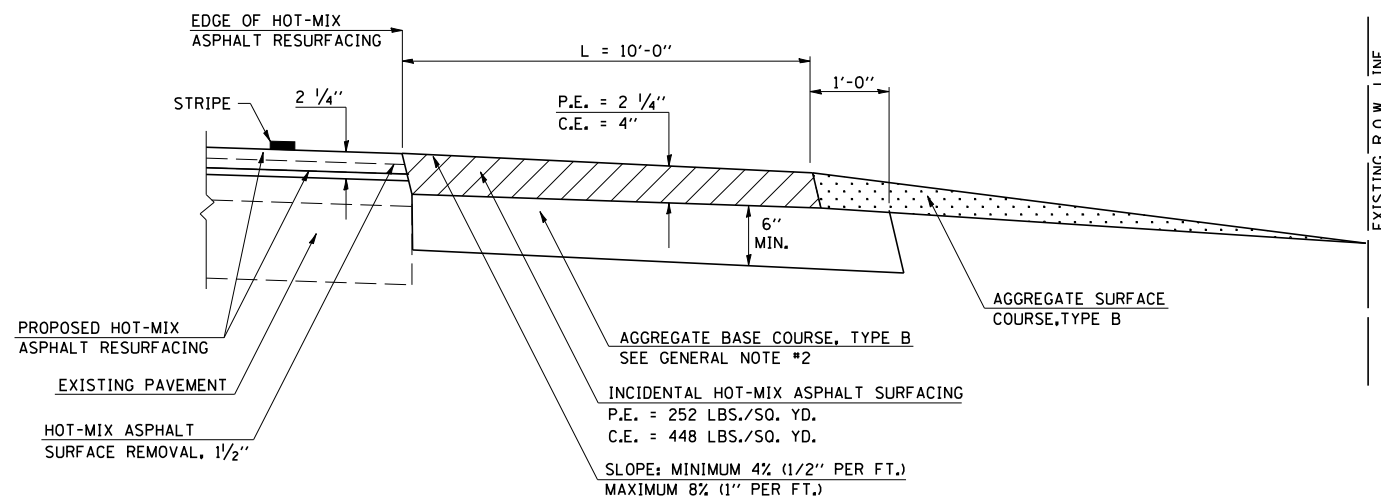

PROFILE

GENERAL NOTES

1. THE EXISTING SURFACE SHALL BE PREPARED IN ACCORDANCE WITH SECTION 408 OF THE STANDARD SPECIFICATIONS.
2. AGGREGATE BASE COURSE, TYPE B, 6" (150 mm) MIN. SHALL BE USED WHERE IN THE OPINION OF THE ENGINEER THERE IS NOT SUFFICIENT BASE MATERIAL FOR THE PROPOSED ENTRANCES. THIS MATERIAL SHALL GENERALLY BE USED TO WIDEN ANY EXISTING RETURN OR TO CONSTRUCT NEW ENTRANCES WHERE NONE NOW EXISTS.
3. THE AGGREGATE BASE COURSE SHALL BE CONSTRUCTED 1' (0.3 m) WIDER THAN THE SURFACE DIMENSIONS AS SHOWN ABOVE.
4. ANY NECESSARY WORK BEHIND THE INCIDENTAL HOT-MIX ASPHALT SURFACING SHALL BE AS SHOWN IN THE PLANS AND/OR AS DIRECTED BY THE ENGINEER.

TYPICAL DETAIL OF RURAL MAILBOX TURNOUTS

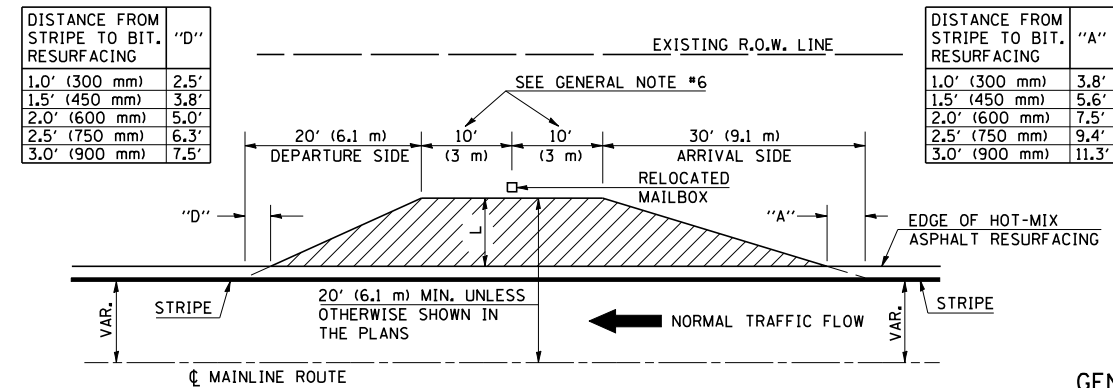

PLAN

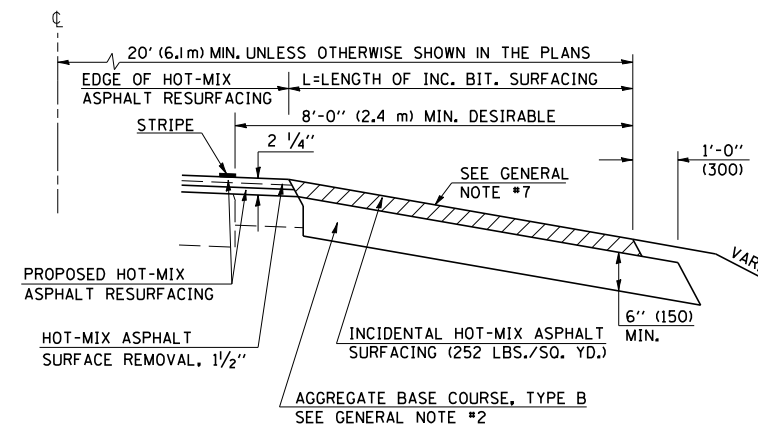

PROFILE

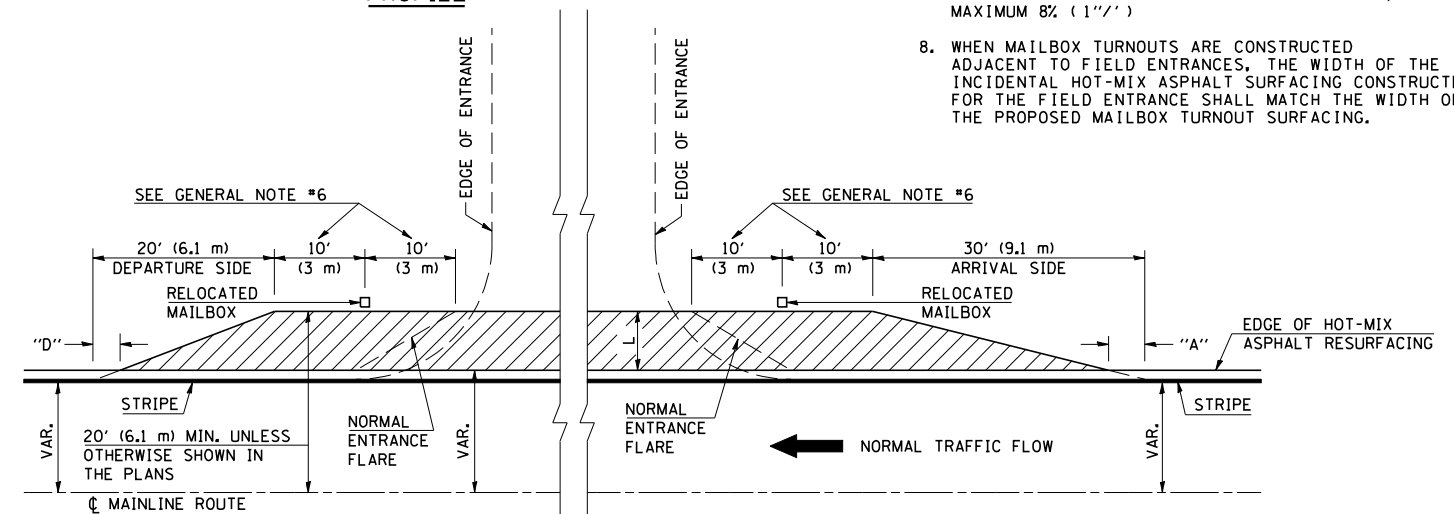

TYPICAL MAILBOX TURNOUT PLACEMENT ADJACENT TO ENTRANCE

GENERAL NOTES

1. THE EXISTING SURFACE SHALL BE PREPARED IN ACCORDANCE WITH SECTION 408 OF THE STANDARD SPECIFICATIONS.
2. AGGREGATE BASE COURSE, TYPE B, 6" (150) MIN. SHALL BE USED WHERE IN THE OPINION OF THE ENGINEER THERE IS NOT SUFFICIENT BASE MATERIAL FOR THE PROPOSED MAILBOX TURNOUTS. THIS MATERIAL SHALL GENERALLY BE USED TO WIDEN ALL EXISTING MAILBOX TURNOUTS OR TO CONSTRUCT NEW MAILBOX TURNOUTS WHERE NONE NOW EXISTS.
3. THE AGGREGATE BASE COURSE SHALL BE CONSTRUCTED 1' (0.3 m) WIDER THAN THE SURFACE DIMENSIONS AS SHOWN ABOVE.
4. ANY NECESSARY WORK BEHIND THE INCIDENTAL HOT-MIX ASPHALT SURFACING SHALL BE AS SHOWN IN THE PLANS AND/OR AS DIRECTED BY THE ENGINEER.
5. THE TEMPORARY RELOCATION OF EXISTING MAILBOXES SHALL BE IN ACCORDANCE WITH ARTICLE 107.20 OF THE STANDARD SPECIFICATIONS.
6. WHEN MORE THAN ONE RELOCATED MAILBOX IS INCLUDED IN A PARTICULAR LOCATION THE TWO 10' (3 m) DIMENSIONS AS SHOWN ABOVE SHALL BE FROM THE END MAILBOX.
7. CROSS SLOPE SHALL BE AS SHOWN ON THE STATION CROSS SECTIONS AND/OR AS DIRECTED BY THE ENGINEER. MINIMUM 4% (1/2"/') DESIRABLE; MAXIMUM 8% (1"/')
8. WHEN MAILBOX TURNOUTS ARE CONSTRUCTED ADJACENT TO FIELD ENTRANCES, THE WIDTH OF THE INCIDENTAL HOT-MIX ASPHALT SURFACING CONSTRUCTED FOR THE FIELD ENTRANCE SHALL MATCH THE WIDTH OF THE PROPOSED MAILBOX TURNOUT SURFACING.

ALL DIMENSIONS ARE IN INCHES (MILLIMETERS) UNLESS OTHERWISE SHOWN.