

F.A. RTE. VAR.	SECTION	COUNTY	TOTAL SHEETS	SHEET NO.
*	*	**	35	30

\* D5 CRACK & JOINT SEAL 2008-1  
 \*\* DEWITT/PIATT/MCLEAN

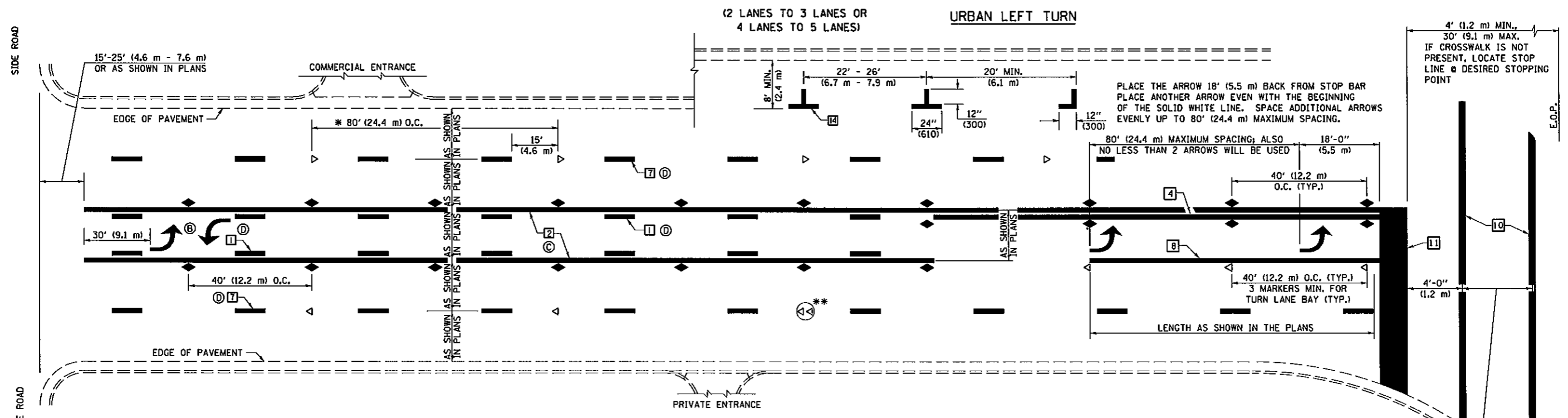

\* REDUCE TO 40 FEET (12.2 METERS) ON CENTER ON CURVES WHERE ADVISORY SPEEDS ARE 10 MPH (15 km/h) LOWER THAN POSTED SPEEDS.

\*\* DOUBLE LANE LINE MARKERS SHALL BE SPECIFIED AND SPACED AS SHOWN IN HIGHWAY STANDARD 781001 FOR MULTI-LANE DIVIDED AND UNDIVIDED HIGHWAYS.

BLOOMINGTON-NORMAL CITY LIMITS ONLY

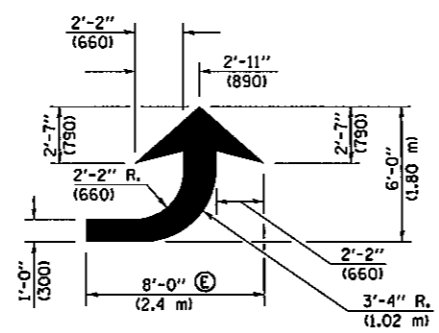

LEFT ARROW  
 REVERSE FOR RIGHT ARROW  
 AREA = 15.6 SQ. FT. (1.47 m<sup>2</sup>) (WHITE)

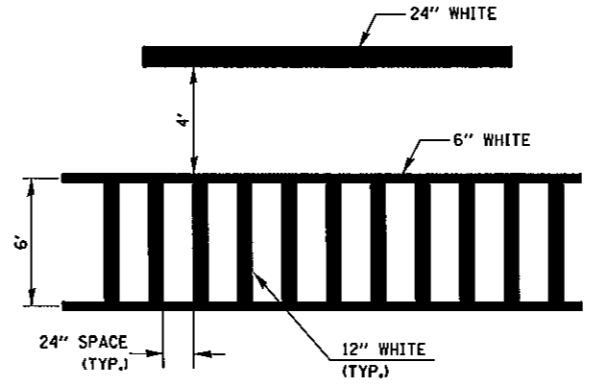

TYPICAL SPACING FOR CROSSWALKS & STOP BARS

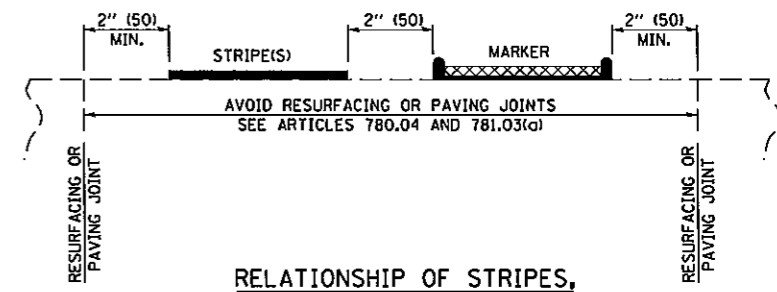

RELATIONSHIP OF STRIPES, MARKERS AND JOINTS

- GENERAL NOTES:**
- (B) TURN ARROW PAIRS SHALL BE PLACED AT 250' (75 m) INTERVALS AND SHALL BE EVENLY SPACED BETWEEN BOTH ENDS OF THE BIDIRECTIONAL LEFT TURN LANE.
  - (C) THE SOLID YELLOW PAVEMENT MARKINGS [2] SHOULD GENERALLY START OR END NEAR THE RADIUS POINT OF EACH STREET RETURN EXCEPT WHERE ONE OR BOTH ENDS WOULD INCLUDE STOP BARS.
  - (D) THE SKIP-DASH PAVEMENT MARKINGS [1] OR [7] SHOULD BE CENTERED BETWEEN BOTH ENDS OF EACH CITY BLOCK AND SHALL BE PLACED SO THEY LINE UP ACROSS FROM EACH OTHER. SEE EXAMPLE ON SHEET 2 OF 3.
  - (E) USE LARGE ARROW SIZE FOR BOTH RURAL AND URBAN LOCATIONS. (SEE LAST PAGE OF SECTION 780x FOR SYMBOLS TABLE)

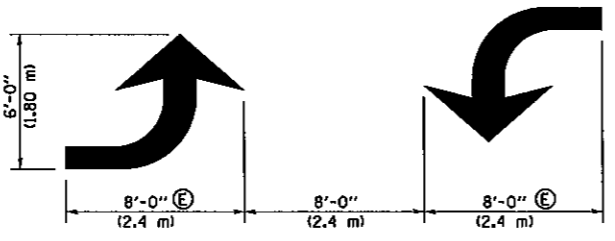

TYPICAL DOUBLE TURN ARROWS (WHITE)

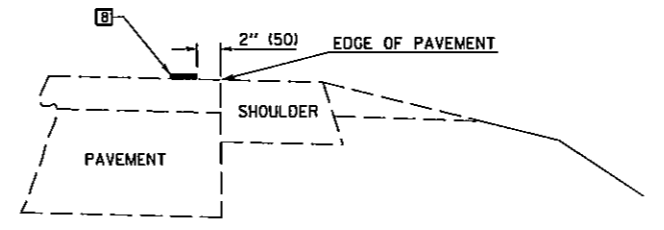

RELATIONSHIP OF EDGE LINE TO EDGE OF PAVEMENT (SAFETY SHOULDER OR PAVED SURFACE) SEE ARTICLE 780.04

Note: All dimensions are in INCHES (millimeters) unless otherwise shown.

DATE	REVISIONS	NAME
11/06	REPLACED DETAIL F-5.25	TJB

ILLINOIS DEPARTMENT OF TRANSPORTATION	
<b>PAVEMENT MARKING AND MARKERS (RURAL &amp; URBAN APPLICATIONS)</b>	
<b>DISTRICT 5 DETAIL NO. 7800AAAA</b>	

PLOT DATE = 9/21/2007  
 FILE NAME = c:\pave\mkt\70658\mkt.dgn  
 PLOT SCALE = 43.191 / IN.  
 USER NAME = gollubch