

STATE OF ILLINOIS
DEPARTMENT OF TRANSPORTATION

CONTRACT NO. 72659				
F.A.I. RTE.	SECTION	COUNTY	TOTAL SHEETS	SHEET NO.
*	**	SANGAMON	248	225
FED. ROAD DIST. NO.		ILLINOIS FED. AID PROJECT		
* F.A.I. 55, F.A.I. 72, F.A.P. 666				
** D6 Interstate RS, BR, M CAB 2008				

Sheet No. 6
of 7 Sheets

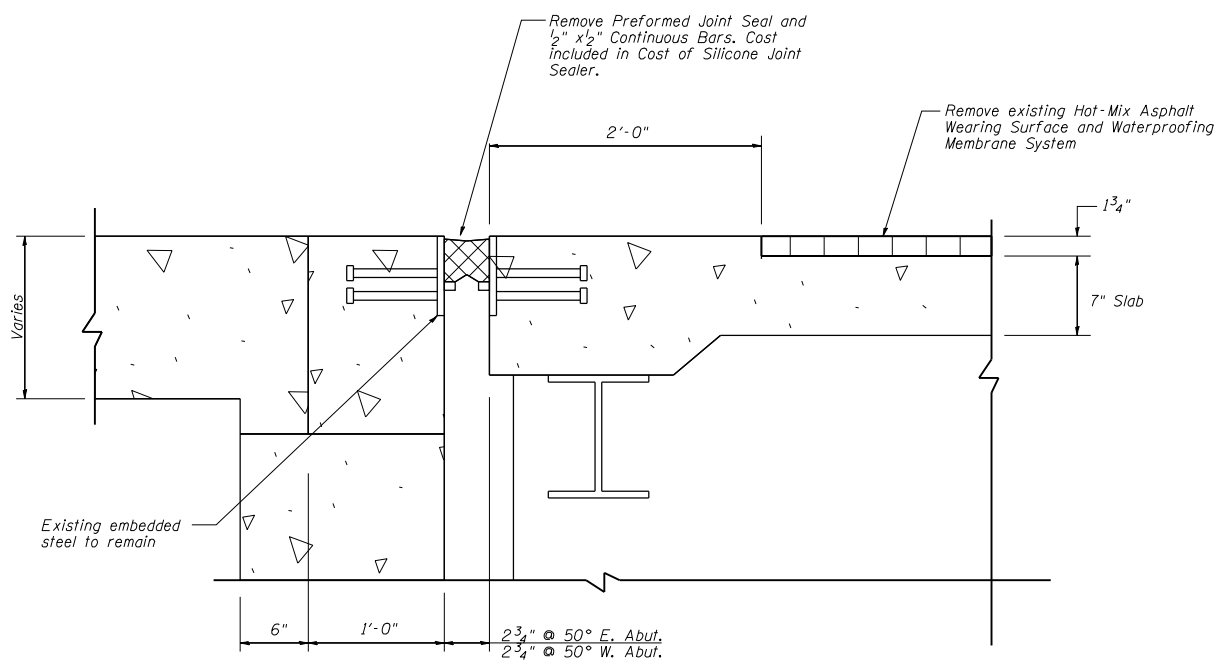

EXISTING SECTION AT ABUTMENT

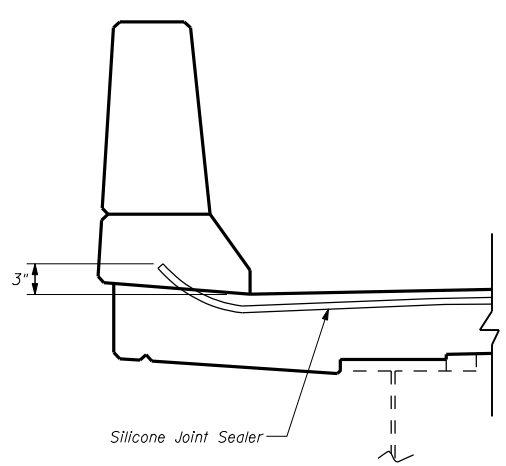

TYPICAL END OF SEAL TREATMENT

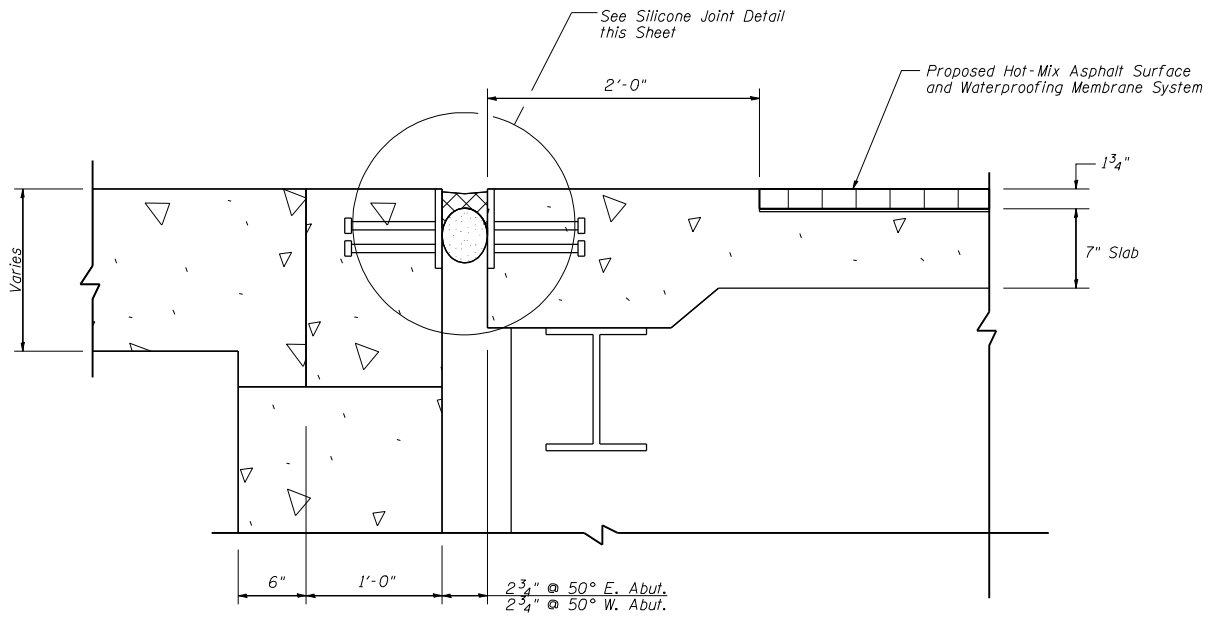
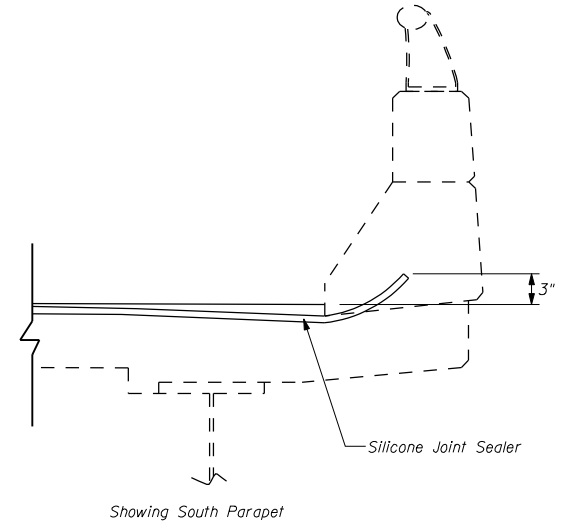

PROPOSED SECTION AT ABUTMENT

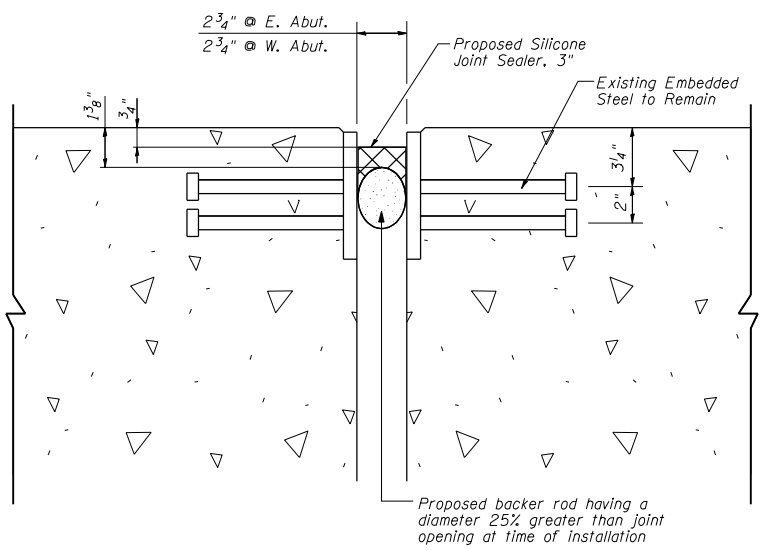

SILICONE JOINT DETAIL

BILL OF MATERIAL

Item	Unit	Quantity
Silicone Joint Sealer, 2 3/4"	Foot	106

NOTES:

1. See Sheet 4 of 7 for Limits of Expansion Joint Replacement.
2. Abrasive blasting and priming of the embedded steel plates shall be performed in accordance with the surface preparation requirements of the special provision for "Silicone Bridge Joint Sealer."

EXPANSION JOINT DETAILS
F.A.I. 55, F.A.I. 72, F.A.P. 666
Section D6 Interstate RS, BR, M CAB 2008
Sangamon County
EB 1-72 Over BU-55
S.N. 084-0077