

STATE OF ILLINOIS  
DEPARTMENT OF TRANSPORTATION

ROUTE NO.	SECTION	COUNTY	FED. SHEETS	SHEET NO.	SHEET NO. 4
#	**	Sangamon	248	247	5 SHEETS
FED. ROAD DIST. NO. 7		ILLINOIS FED. AID PROJECT-			

Contract # 72659  
\* FAI 55 (I-55), FAI 72 (I-72) FAP 666 (I-55 BUS)  
\*\* D6 Interstate RS, BR, M CAB 2008

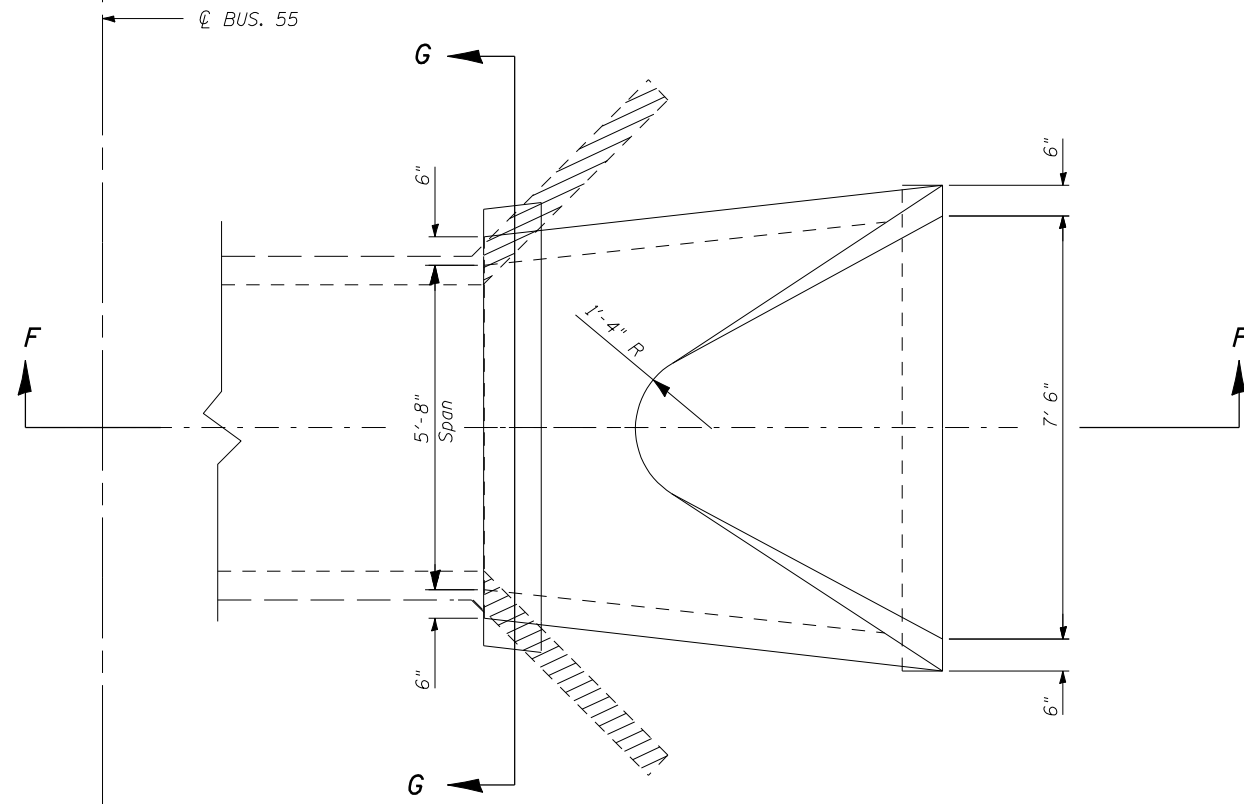

PLAN

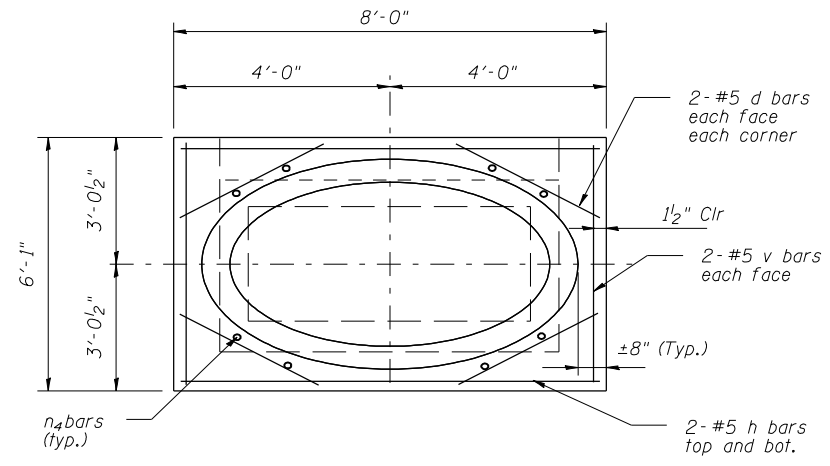

Section G-G

BILL OF MATERIAL

Bar	No.	Size	Length	Shape
d	8	#5	5'-0"	—
h	4	#5	7'-8"	—
n4	8	#5	2'-0"	—
v	4	#5	5'-9"	—
Concrete Collar			Cu. Yd.	2.3
Reinforcement Bars			Pound	120
Concrete Removal			Cu. Yd.	1.3
Precast Reinforced concrete Flared End Section Eq. Dia. 54"			Each	1
Grating for Concrete End Section ERS 54"			Each	1

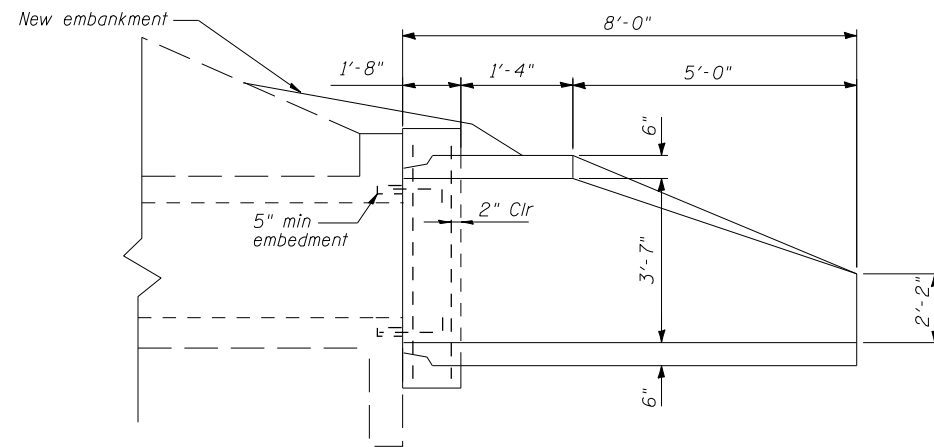

Section F-F

Ellipse inside dimensions:  
See Standard 542306  
Span = 68"  
Rise = 43"  
Walls = 6"

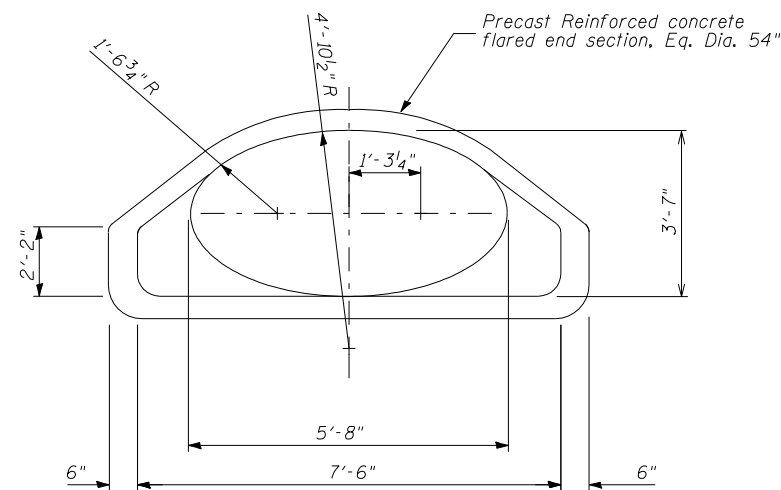

END VIEW

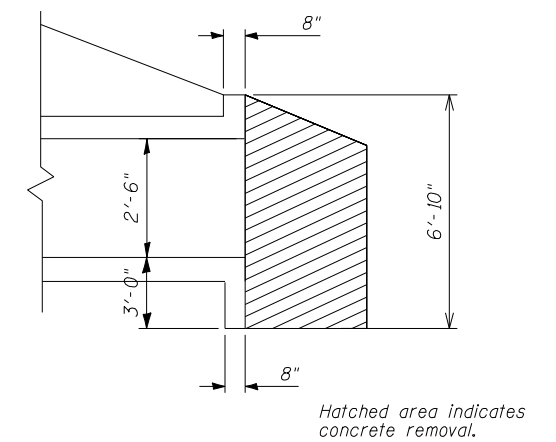

EXISTING OUTLET

DESIGNED	KRG
CHECKED	MJK
DRAWN	G SJ
CHECKED	MJK

MID-AMERICA ENGINEERING SERVICES

DOWNSTREAM EXTENSION  
FAP 666 (I-55 BUS)  
SECTION: D6 INTERSTATE RS, BR, M CAB 2008  
SANGAMON COUNTY