

F.A.P. RTE.	SECTION	COUNTY	TOTAL SHEETS	SHEET NO.
321	18(N-1,TS)	PIKE	55	34
STA.		TO STA.		
FED. ROAD DIST. NO.	ILLINOIS	FED. AID PROJECT		

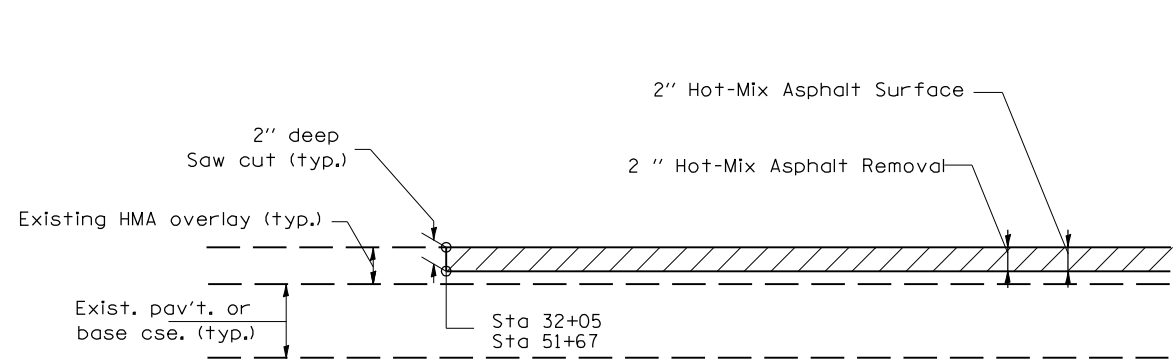

RAMPING DETAIL
US 54/IL 106

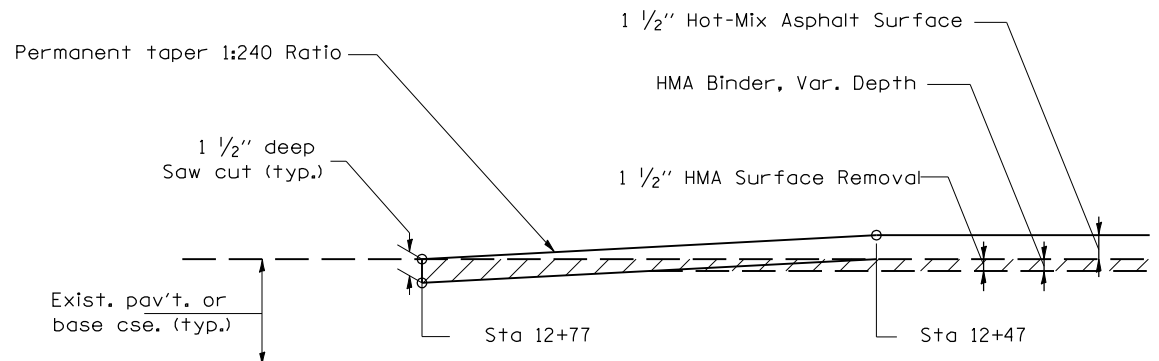

BUTT JOINT DETAIL
FRANKLIN ST. (NORTH)

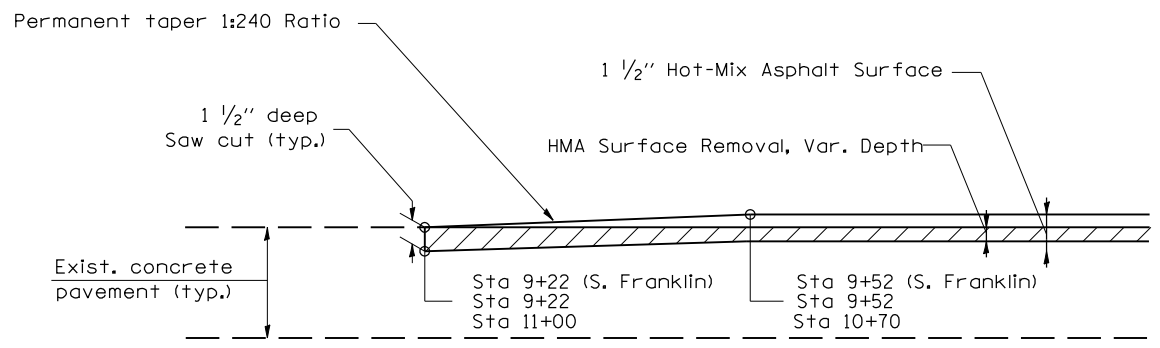

BUTT JOINT DETAIL
FRANKLIN ST. (SOUTH)
& CLINTON ST.

- NOTES: 1. THE SAW CUTS FOR BUTT JOINTS SHALL BE INCLUDED IN THE COST OF HOT-MIX ASPHALT SURFACE REMOVAL (VARIABLE DEPTH).
2. THE SAW CUTS FOR THE RAMPING DETAIL SHALL BE INCLUDED IN THE COST OF HOT-MIX ASPHALT SURFACE REMOVAL 2".

PLOT DATE = 04-20-2007 01:06:23PM
 FILE NAME = c:\p\projects\6551804\detail.dgn
 PLOT SCALE = 4.23525 / IN.
 USER NAME = laughlin-1

REVISIONS	
NAME	DATE

ILLINOIS DEPARTMENT OF TRANSPORTATION
 BUTT JOINT/ RAMPING DETAIL
 FAP 321 (US 54)
 SECTION 18(N-1,TS)
 PIKE COUNTY

SCALE: VERT. _____
 HORIZ. _____

DATE _____ DRAWN BY _____
 CHECKED BY _____