

FOR INDEX OF SHEETS AND HIGHWAY
STANDARDS, SEE SHEET 2.

STATE OF ILLINOIS
DEPARTMENT OF TRANSPORTATION
DIVISION OF HIGHWAYS
**PLANS FOR PROPOSED
D.E. MISCELLANEOUS
FAP ROUTE 310 (U.S. 67)
SECTION 69-12I
MORGAN COUNTY
C96-017-08 / D96-017-08**

CONTRACT: 72B59
SHEET 1 OF 9

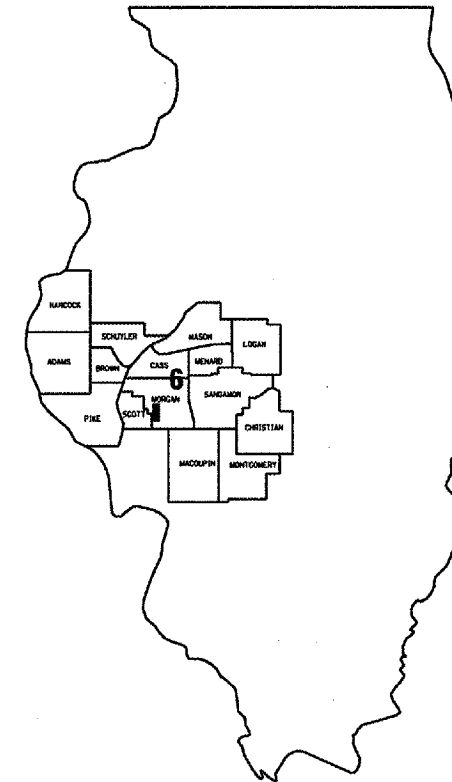

LOCATION OF SECTION INDICATED THUS: ■

PROJECT LOCATION
U.S. 67 & BIRDSSELL RD.

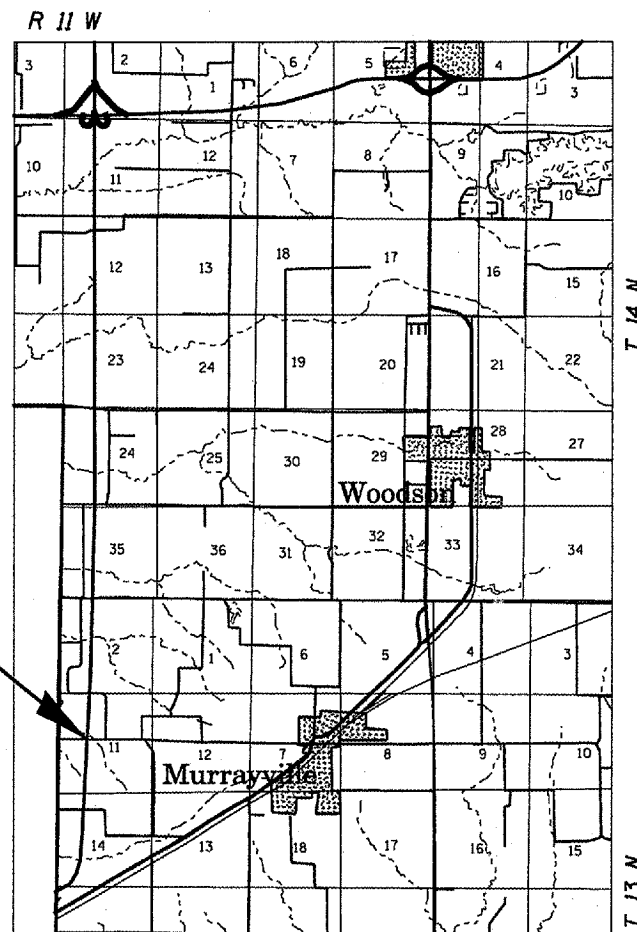

J. U. L. I. E.
JOINT UTILITY LOCATION INFORMATION FOR EXCAVATION
1-800-892-0123

PLANS & CONTRACT TECHNICIAN: TIMOTHY SHARP
PHONE: (217) 782-7743

NET LTH OF SEC 761.00 FT = 0.144 MILE

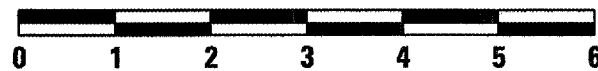

SCALE: 1" = 2 MILES

STATE OF ILLINOIS
DEPARTMENT OF TRANSPORTATION
DIVISION OF HIGHWAYS

SUBMITTED Oct 3 20 07

W. M. Beedum
DEPUTY DIRECTOR OF HIGHWAYS, REGION FOUR ENGINEER

December 7, 20 07
Eric E. Harrel
Interim ENGINEER OF DESIGN AND ENVIRONMENT

December 7, 20 07
Christine M. Reed
DIRECTOR, DIVISION OF HIGHWAYS

CONTRACT NO. 72B59



PRINTED BY AUTHORITY OF THE STATE OF ILLINOIS

INDEX

- 1 COVER
- 2 INDEX/STANDARDS/SIGNATURES
- 3 QUANTITIES
- 4 ELECTRICAL PLAN
- 5-9 ELECTRICAL DETAILS

STANDARDS

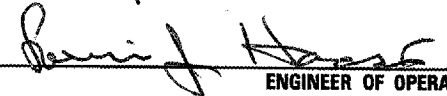
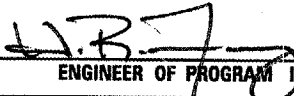
- 701101-01
- 701106-01
- 701400-02
- 701401-04
- 701901

STATE OF ILLINOIS DEPARTMENT OF TRANSPORTATION DIVISION OF HIGHWAYS DISTRICT 6	
EXAMINED	Sept 24 20 07
	 ENGINEER OF OPERATIONS
EXAMINED	Sept 20 20 07
	 ENGINEER OF PROGRAM IMPLEMENTATION
EXAMINED	Sept 27 20 07
	 ENGINEER OF PROGRAM DEVELOPMENT

NOTE:
IT IS AN IDOT COMMITMENT TO HAVE ALL LIGHTING COMPLETED AND OPERATIONAL
BY JUNE 15, 2008 PRIOR TO MURRAYVILLE'S SESQUICENTENNIAL CELEBRATION.

INDEX/STANDARDS/SIGNATURES
FAP 310 (U.S. 67)
SECTION 69-12I
MORGAN COUNTY





S U M M A R Y O F Q U A N T I T I E S

CODE NO.	ITEM	UNIT	100% STATE
			Y030-1E TOTAL QTY
67100100	MOBILIZATION	L SUM	1
70100800	TRAFFIC CONTROL AND PROTECTION, STANDARD 701401	L SUM	1
80400100	ELECTRIC SERVICE INSTALLATION	EACH	1
81020700	CONDUIT PUSHED, 3" DIA. INTERMEDIATE METAL	FOOT	238
81603000	UNIT DUCT, 600V, 2-1C NO.8, 1/C NO.8 GROUND, (XLP-TYPE USE) 3/4" DIA. POLYETHYLENE	FOOT	1,335
81900200	TRENCH AND BACKFILL FOR ELECTRICAL WORK	FOOT	948
82103900	LUMINAIRE, SODIUM VAPOR, MULTI-MOUNT, 250 WATT	EACH	10
82500605	LIGHTING CONTROLLER PHOTOCELL RELAY	EACH	1
83062730	LIGHT POLE, WEATHERING STEEL, 45 FT. M.H., TENON MOUNT	EACH	6
83062735	LIGHT POLE, WEATHERING STEEL, 45 FT. M.H., TENON MOUNT - TWIN	EACH	2
83600355	LIGHT POLE FOUNDATION METAL, 15" BOLT CIRCLE, 8" X 6'	EACH	6
83600357	LIGHT POLE FOUNDATION METAL, 15" BOLT CIRCLE, 8" X 8'	EACH	2
83800650	BREAKAWAY DEVICE, COUPLING, WITH STAINLESS STEEL SCREEN	EACH	32

QUANTITIES
FAP 310 (U.S. 67)
SECTION 69-12I
MORGAN COUNTY



Rev.

LEGEND

-  EXISTING UTILITY POLE
-  CONDUIT PUSHED, 3" DIA. INTERMEDIATE METAL
-  UNIT DUCT, 600V, 2-1/C NO. 8, 1/C NO. 8 GROUND. (XLP - TYPE USE), 3/4" DIA. POLYETHYLENE
-  45 FT. WEATHERING STEEL POLE ON BREAKAWAY COUPLINGS, 250W HIGH PRESSURE SODIUM MULTI-MOUNT LUMINAIRE ON TENON

-  45 FT. WEATHERING STEEL POLE ON BREAKAWAY COUPLINGS, 2-250W HIGH PRESSURE SODIUM MULTI-MOUNT LUMINAIRE ON TENON AT 90 DEGREES APART

-  LIGHTING CONTROLLER PHOTOCELL RELAY, 30 AMP, 120/240V

-  CONTROLLER NUMBER
-  CIRCUIT
-  POLE NUMBER

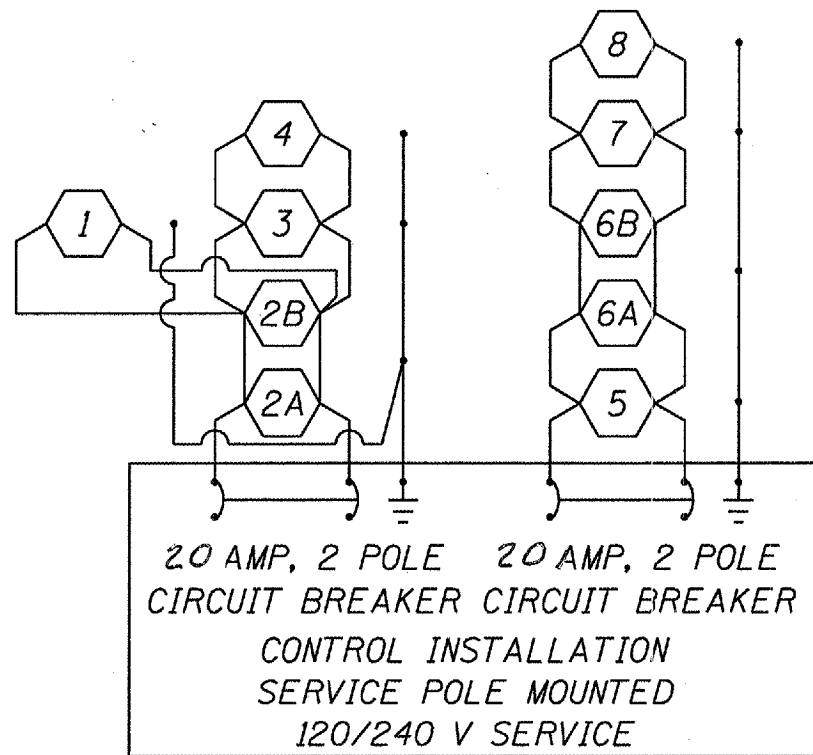

CONTROL INSTALLATION CIRCUIT DIAGRAM

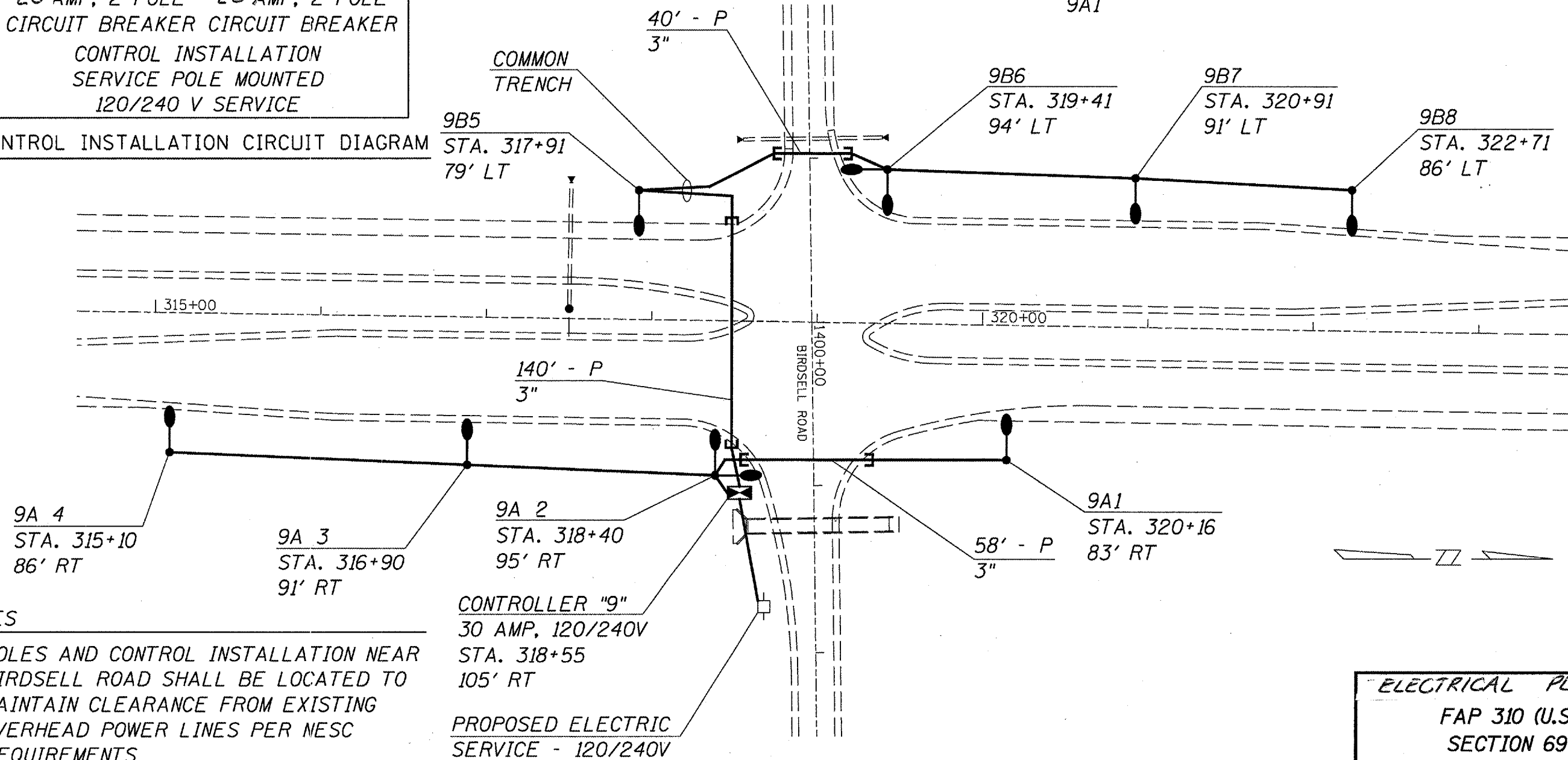

NOTES

POLES AND CONTROL INSTALLATION NEAR BIRDELL ROAD SHALL BE LOCATED TO MAINTAIN CLEARANCE FROM EXISTING OVERHEAD POWER LINES PER NESC REQUIREMENTS

CONTROLLER "9"
30 AMP, 120/240V
STA. 318+55
105' RT

PROPOSED ELECTRIC SERVICE - 120/240V

ELECTRICAL PLAN
FAP 310 (U.S. 67)
SECTION 69-12I
MORGAN COUNTY

Rev.

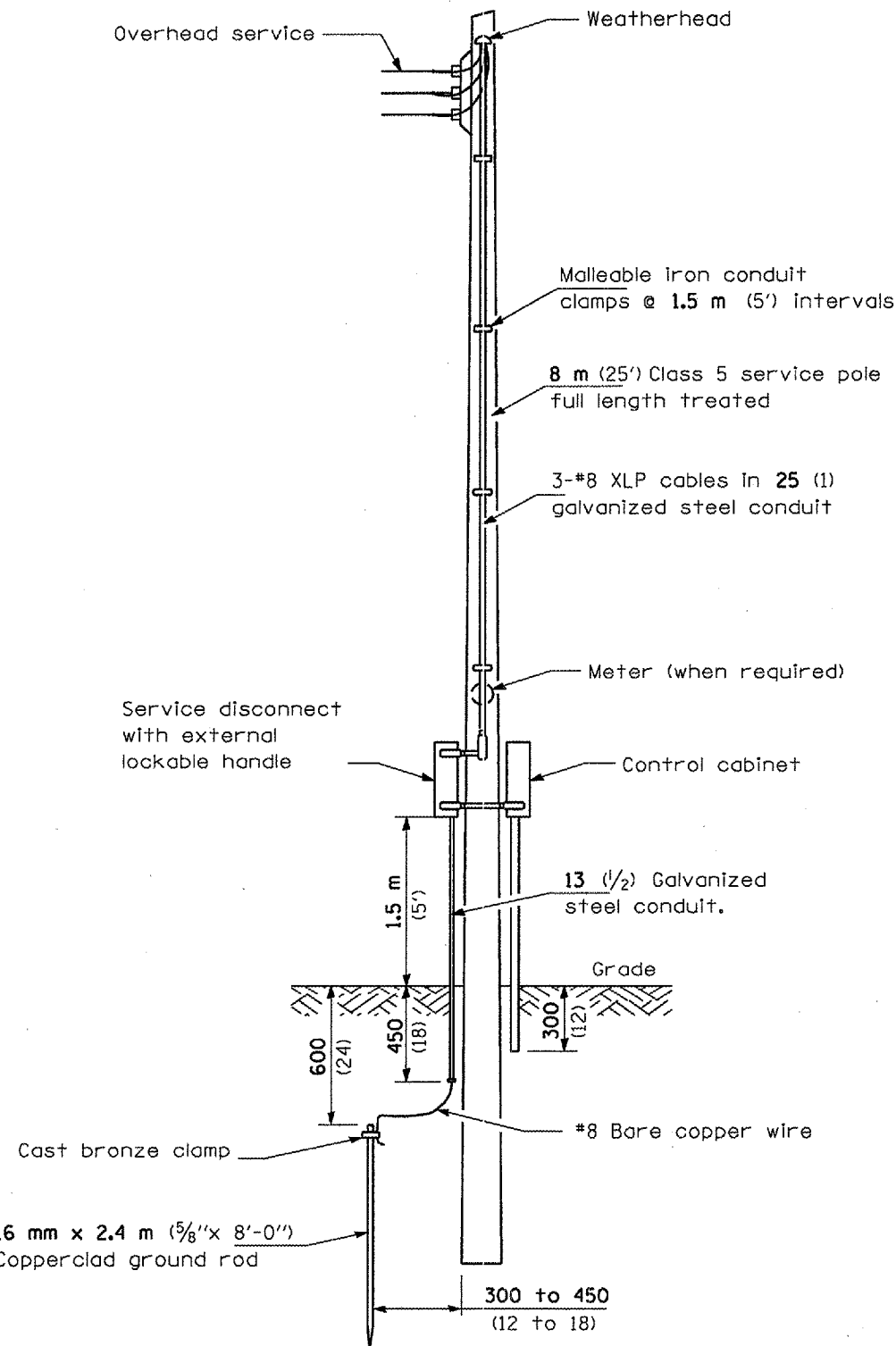

SERVICE POLE

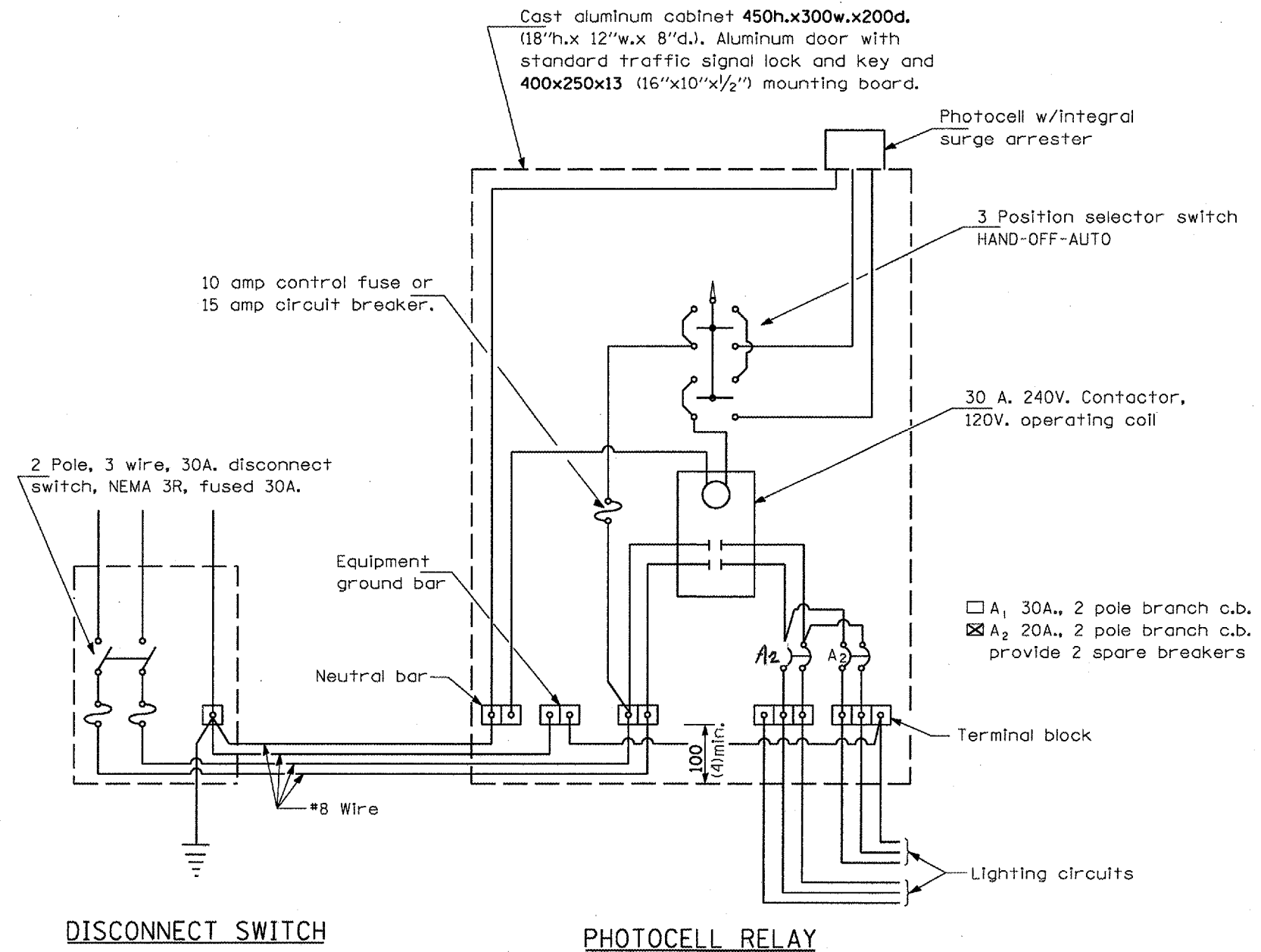

DISCONNECT SWITCH

PHOTOCELL RELAY

GENERAL NOTES

All equipment shall be U.L. Listed.

All dimensions are in millimeters unless otherwise shown.

All dimensions are minimum and shall be increased as necessary to meet the standard specifications,

FAP 310 (U.S. 67)
SECTION 69-121
MORGAN COUNTY

DATE	REVISIONS

CONTROL INSTALLATION
SERVICE POLE MOUNTED

120/240V., 1 PHASE, 3 WIRE SERVICE

LGTO03.M32

LIGHT POLE MOUNTING HEIGHT	BOLT CIRCLE DIAMETER	STEEL FOUNDATION			CONCRETE FOUNDATION		
		SHAFT DIAMETER	SHAFT DEPTH	TOP PLATE (min)	SHAFT DIAMETER	SHAFT DEPTH	ANCHOR ROD LENGTH ①
< 9.1 m (30')	292 (11.5)	220 (8 5/8)	1.83 m (6')	300 x 300 x 25 12 x 12 x 1	610 (24)	1.52 m (5'-0")	1.45 m (4'-9")
9.4 m - 10.7 m (31'-35')	292 (11.5)	220 (8 5/8)	1.83 m (6')	300 x 300 x 25 12 x 12 x 1	610 (24)	1.67 m (5'-6")	1.60 m (5'-3")
10.9 m - 12.2 m (36'-40')	381 (15) ③	220 (8 5/8)	1.83 m (6') ②	375 x 375 x 31 15 x 15 x 1 1/4	762 (30)	1.83 m (6'-0")	1.75 m (5'-9")
12.5 m - 13.7 m (41'-45')	381 (15) ③	220 (8 5/8)	1.83 m (6') ②	375 x 375 x 31 15 x 15 x 1 1/4	762 (30)	1.98 m (6'-6")	1.90 m (6'-3")
14.0 m - 15.2 m (46'-50')	381 (15) ③	220 (8 5/8)	2.44 m (8')	375 x 375 x 31 15 x 15 x 1 1/4	762 (30)	2.13m (7'-0")	2.00 m (6'-9")

- ① Length does not include 100(4)hook
- ② 220 mm x 2.44 m (8 5/8" x 8'-0") for Twin luminaires
- ③ Bolt circle diam. shall be 430 (17) when a TB3-17 transformer base is used

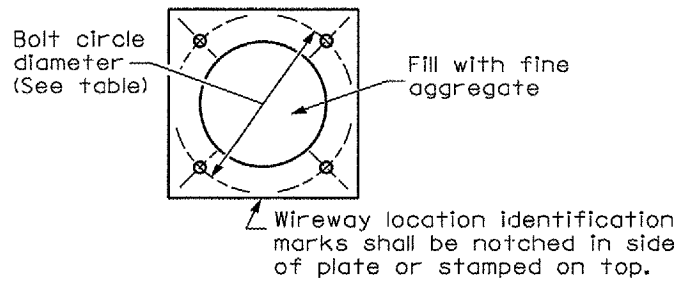

Length above foundation shall be adjusted to accommodate breakaway devices furnished by the contractor for a specific installation.

610 (24) min. dia. with 292 (11.5) bolt circle
762 (30) min. dia. with 381 (15) or 432 (17) bolt circle

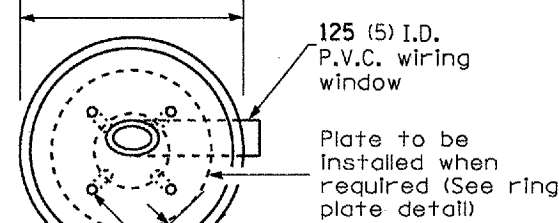

125 (5) I.D. P.V.C. wiring window

Plate to be installed when required (See ring plate detail)

75 (3) Min. concrete cover on all steel

Anchor rod 25 (1) diameter with 230 (9) threads. Anchor rod shall extend through nut 25 (1). For barrier or foundation behind guardrail, use self-locking nut and flat washer. Do not use lock washer.

Pole Foundation Setback:

For horizontal mounted luminaires, setback shall be a minimum of 6.1 m (20') from edge of pavement.

For vertical mount luminaires, setback shall be a minimum of 9 m (30') from edge of pavement. Poles shall be located 1.5 m (5') behind guardrail or other protective barriers, or as directed by the Engineer.

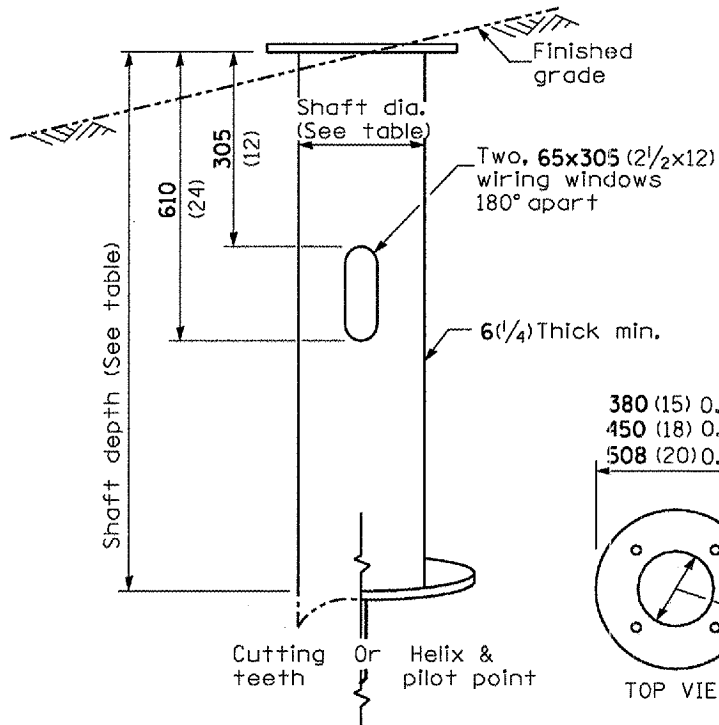
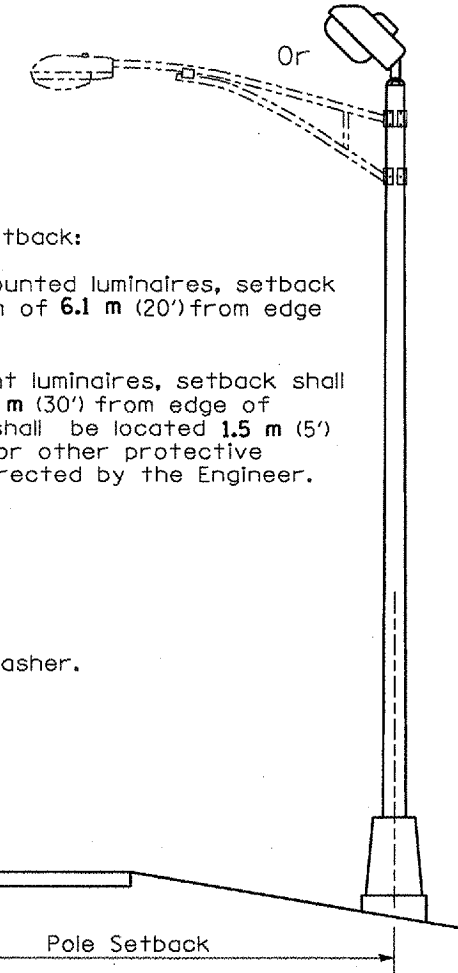

STEEL FOUNDATION

Use dirt removed from foundation to meet 1.52m (5 ft.) chord fill around foundation top. Grade dirt level with bottom of concrete chamfer.

- ④ If the required anchor rod length above top of foundation is less than 75 (3), anchor rods may be lowered below 150 (6).

380 (15) O.D.
450 (18) O.D.
508 (20) O.D.

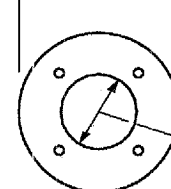

RING PLATE DETAIL

(When rock is encountered and foundation is shallower)

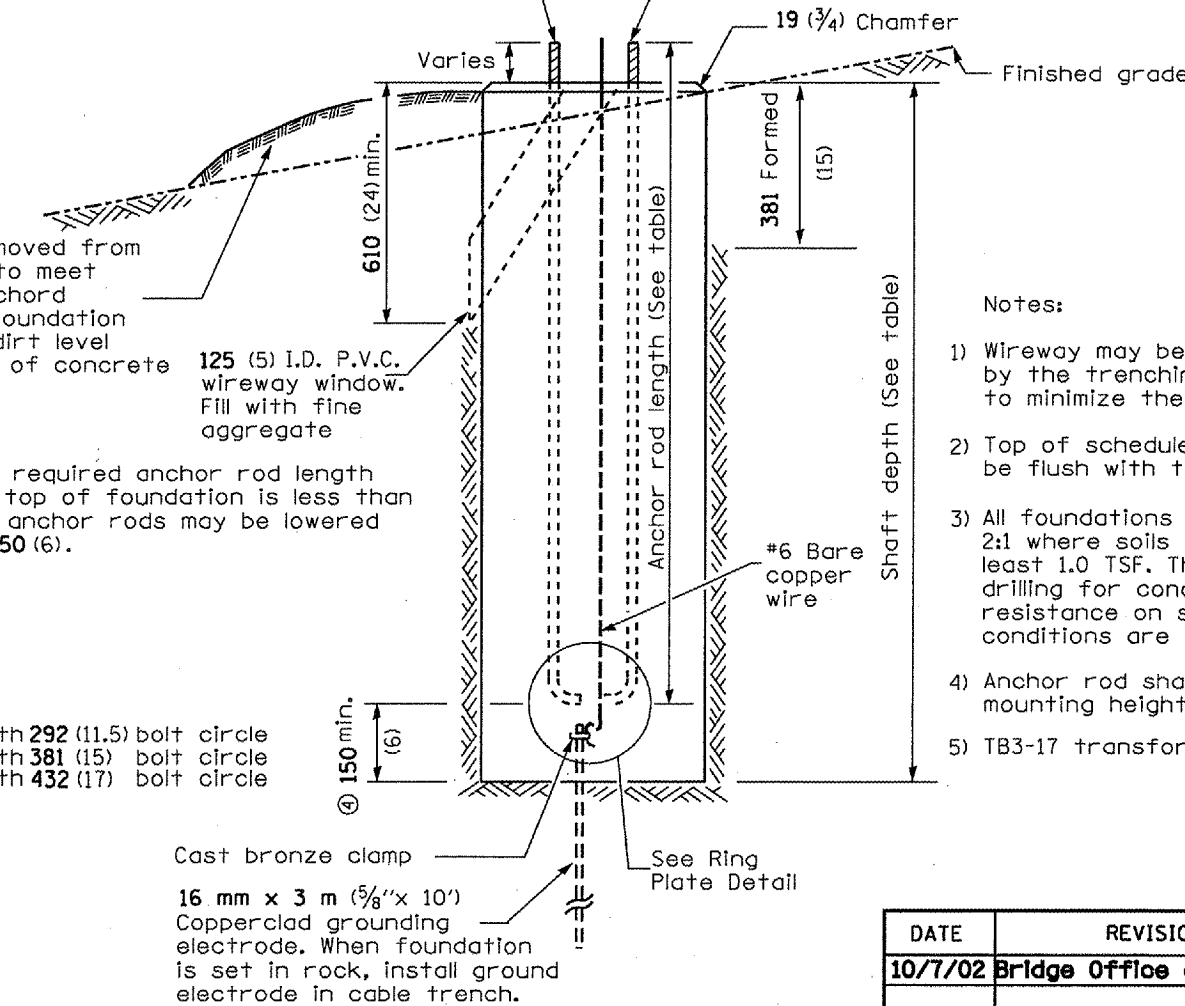

CONCRETE FOUNDATION

Cast bronze clamp
16 mm x 3 m (5/8" x 10') Copperclad grounding electrode. When foundation is set in rock, install ground electrode in cable trench.

Notes:

- 1) Wireway may be on front, back or side of foundation as required by the trenching. Place door of transformer base on wireway side to minimize the number of unit duct bends.
- 2) Top of schedule 40 125 (5) I.D. PVC wiring window, shall be flush with the top of foundation for drainage.
- 3) All foundations are designed to be located on slopes not exceeding 2:1 where soils have an unconfined compressive strength of at least 1.0 TSF. The contractor shall verify the soil strength during drilling for concrete foundations or by monitoring installation resistance on steel foundations and notify the engineer if other conditions are encountered.
- 4) Anchor rod shall be increased to 31 (1 1/4) diameter for 15.24 (50') mounting height or above.
- 5) TB3-17 transformer base is not to be used on metal foundation

All dimensions are in millimeters (inches) unless otherwise shown.

FAP 310 (U.S. 67)
SECTION 69-121
MORGAN COUNTY

DATE	REVISIONS
10/7/02	Bridge Office depth calc.

LIGHT POLE FOUNDATION

LGT007-836

"Install and orient arm bracket over pole tenon and firmly hand tighten the two set screws. Use third hole in arm bracket as a guide to drill a 8.3 (2/64) diameter hole through tenon. Install and tighten self-tapping screw. Tighten set screws an additional (1/4 to 3/8) turn with hex key (not provided). Install locknuts on set screws if threaded projection allows."

Pole shall meet AASHTO Standard Specifications for 128.72 km (80 mph) wind loading and 40.82 kg (90 lb.), .37 m² (4.0 sq. ft.) E.P.A. luminaire.

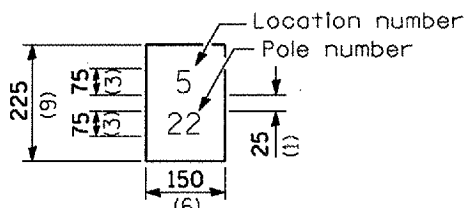

The contractor shall furnish and install a light pole identification of each new light pole, as shown above, incidental to the respective light pole pay item. The numerals shall be 75 (3) series "D", black, screened on silver-white type B pressure sensitive reflective sheeting conforming to the requirements of section T602.01 of the Standard Specifications for Traffic Control Items. The numerals shall conform to the FHWA "Standard Alphabets for Highway Signs".

The light pole identification shall be applied to sign base material as specified in section 1085.05 of the Standard Specifications, approximately 180 (7) above the adjacent pavement grade visible to approaching traffic in accordance with Highway Standard 2319.

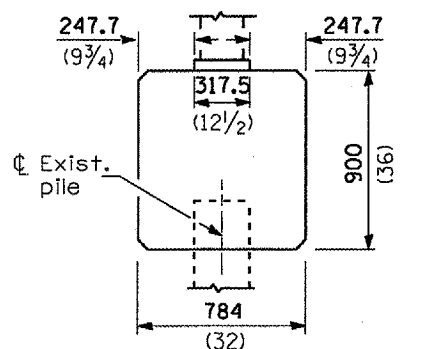
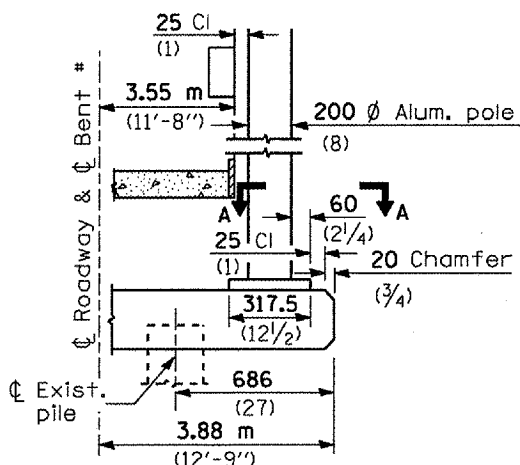

BRIDGE PIER MOUNT

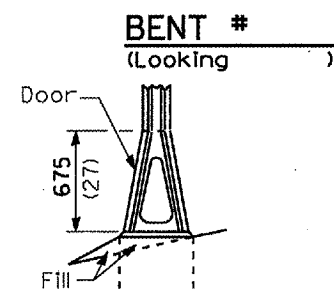

STAINLESS STEEL FLAIR BASE

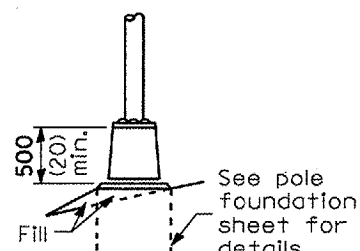

TRANSFORMER BASE

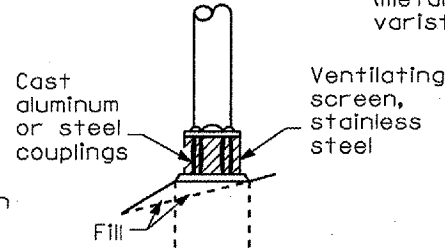

BREAKAWAY COUPLING

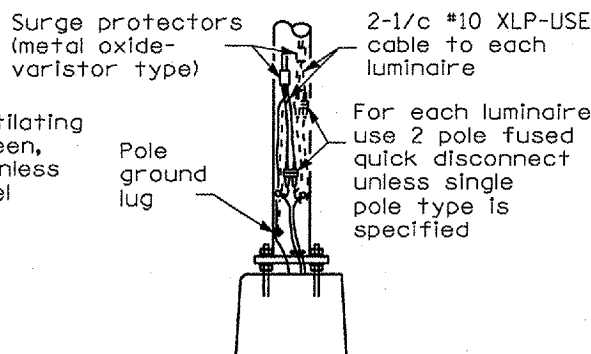

ANCHOR

FAP 310 (U.S. 67)
SECTION 69-121
MORGAN COUNTY

FRANGIBLE

METAL OR CONCRETE

Details for underground distribution if required

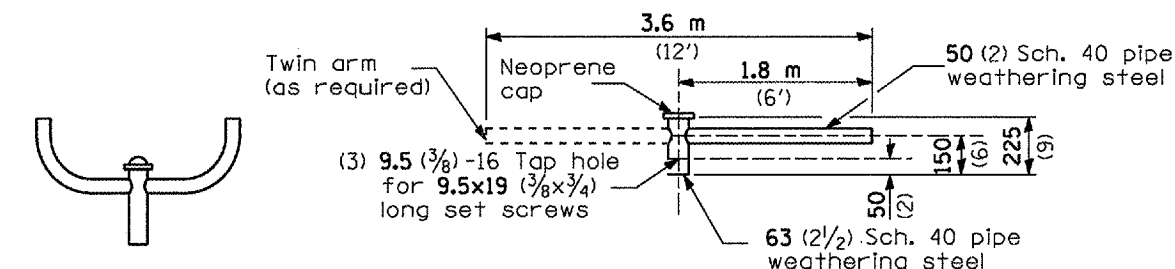

TWIN TENON

TENON MOUNT BRACKET ARM

NOTE: Single or twin arm assembly shall be tilted 3° above horizontal.

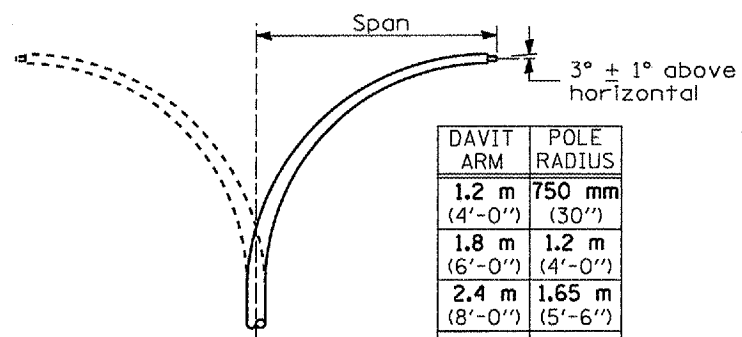

DAVIT ARM
DAVIT ARM-TWIN

DAVIT ARM	POLE RADIUS
1.2 m (4'-0")	750 mm (30")
1.8 m (6'-0")	1.2 m (4'-0")
2.4 m (8'-0")	1.65 m (5'-6")
3.6 m (12'-0")	1.65 m (5'-6")

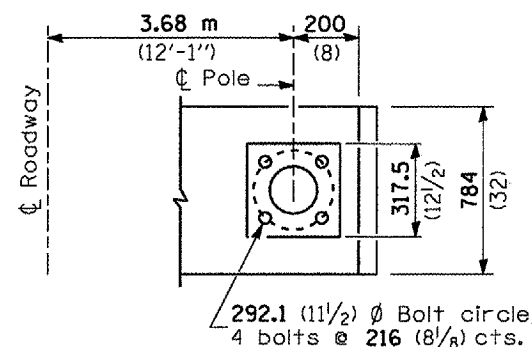

SECTION A-A

- ① Luminaire
- ② Wood pole, class 3 or better
- ③ 63 (2 1/2) Galv. steel conduit
- ④ Single offset pole band
- ⑤ Conduit bushing
- ⑥ Cable clamps on 600 (24) centers
- ⑦ 2/c #12 Type use cable
- ⑧ 25 (1) Galv. steel conduit 3.0 m (10') in length

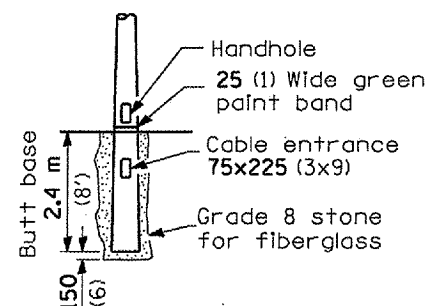

BUTT BASE

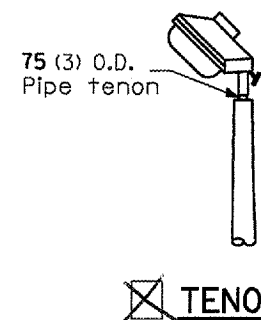

MAST ARM

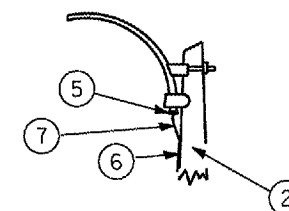

TENON

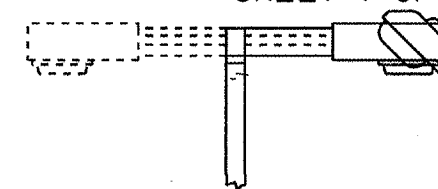

SHORT BRACKET
SHORT BRACKET - TWIN

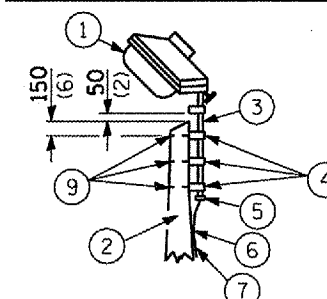

TENON

- ⑨ 16 (5/8) Ø hot dipped galvanized bolt with flat washer & locknut (3 req'd)
- ⑩ Conduit clamps on 900 (36) centers
- ⑪ Unit duct
- ⑫ Threaded reducer
- ⑬ "C" Condulet, threaded
- ⑭ 40 (1 1/2) Galv. steel conduit for 1 unit duct or 75 (3) galv. steel conduit for 2 or 3 unit ducts.

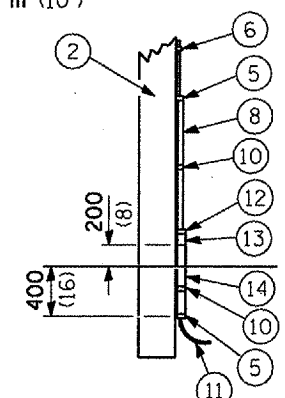

POLE, WOOD

POLE LENGTH	DEPTH IN GROUND
19.8 m (65')	3.6 m (12')
18.0 m (60')	3.0 m (10')
16.8 m (55')	2.7 m (9')
16.0 m (50')	2.4 m (8')
13.7 m (45')	2.1 m (7')
12.0 m (40')	2.0 m (6.5')
10.7 m (35')	1.8 m (6')
9.0 m (30')	1.7 m (5.5')

All dimensions are in millimeters (inches) unless otherwise shown.

DATE	REVISIONS

POLE STANDARDS

LGTO08.M32

Rev.

ILLINOIS DEPARTMENT OF TRANSPORTATION
LUMINAIRE PERFORMANCE TABLE

1/1/03

GIVEN CONDITIONS

ROADWAY DATA:	Pavement Width	48	FT
	Number Of Lanes	4	
	Median Width	14	FT
	IES Surface Classification	R3	
	Q-Zero Value	.07	
LIGHT POLE DATA:	Mounting Height	45	FT
	Mast Arm Length	-	FT
	Pole Set-Back From Edge Of Pavement	30	FT
LUMINAIRE DATA:	Lamp Type	HPS	
	Lamp Lumens	28000	
	IES Vertical Distribution	L	
	IES Control Of Distribution	N	
	IES Lateral Distribution	IV	
	Total Light Loss Factor	0.70	
LAYOUT DATA:	Spacing	150	FT
	Configuration	Stard With Median	
	Luminaire Overhang Over Edge Of Pavement Lane	-30	FT

NOTE: Variations from the above specified IES distribution pattern may be requested and acceptance of variations will be subject to review by the Engineer based on how well the performance requirements are met.

PERFORMANCE REQUIREMENTS

NOTE: These performance requirements shall be the minimum acceptable standards of photometric performance for the luminaire, based on the given conditions listed above.

ILLUMINATION:	Average Horizontal Illumination, (E_{Ave})	0.9	fc
	Uniformity Ratio, (E_{Ave}/E_{Min})	3.0	
LUMINANCE:	Average Luminance: (L_{Ave})	0.6	Cd/m ²
	Uniformity Ratios: (L_{Ave}/L_{Min})	3.5	
	(L_{Max}/L_{Min})	6.0	
	Maximum Veiling Luminance Ratio: (L_v/L_{Ave})	0.3	

FAP 310 (U.S. 67)
SECTION 69-12I
MORGAN COUNTY

DATE	REVISIONS	LUMINAIRE PERFORMANCE TABLE

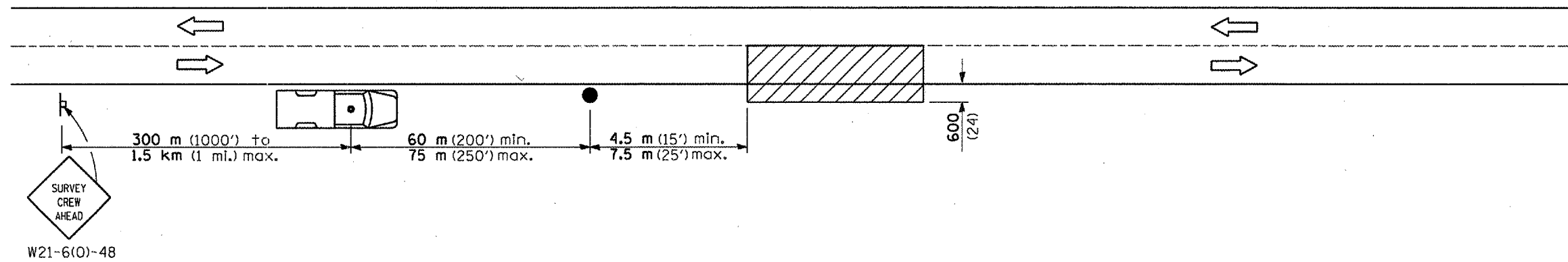

SYMBOLS

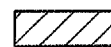

Work area



Sign on portable or permanent support

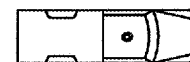

Truck with flashing amber light and dual emergency flashers



Flagger with traffic control sign

TYPICAL APPLICATIONS
Utility operations

All dimensions are in millimeters (inches)
unless otherwise shown.

FAP 310 (U.S. 67)
SECTION 69-12I
MORGAN COUNTY

DATE	REVISIONS

DETAIL FOR
NIGHTTIME LIGHTING
INSPECTION