

F.A.P. RTE.	SECTION	COUNTY	TOTAL SHEETS	SHEET NO.
B69	101BR-1	FRANKLIN	28	9
STA.		TO STA.		
FED. ROAD DIST. NO. -		ILLINOIS	FED. AID PROJECT	

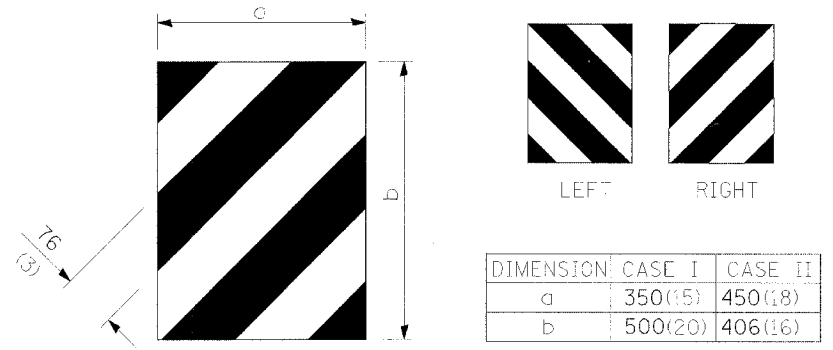

TERMINAL MARKER DETAILS
Color: Black / Yellow reflectorized

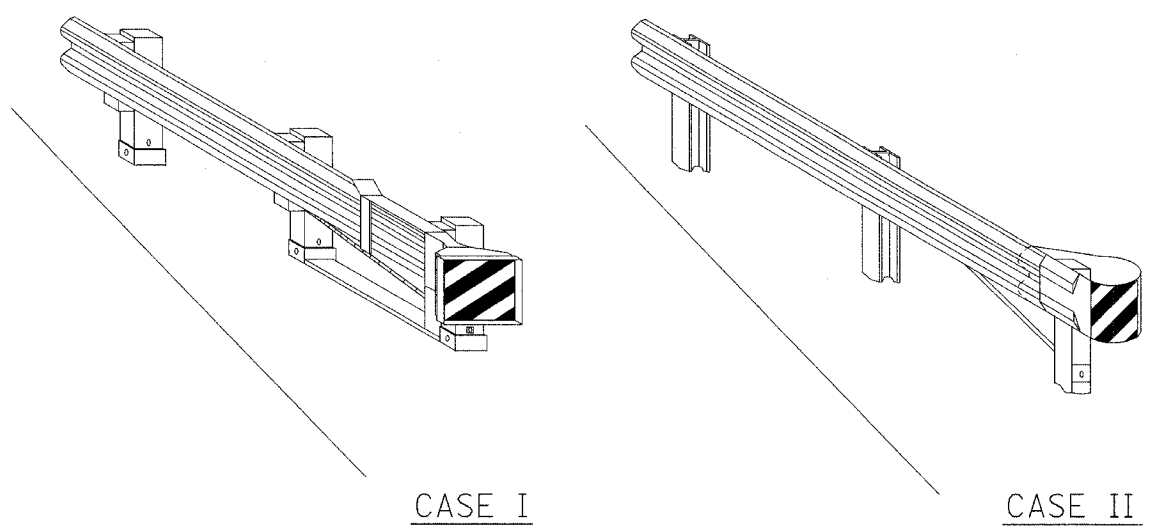
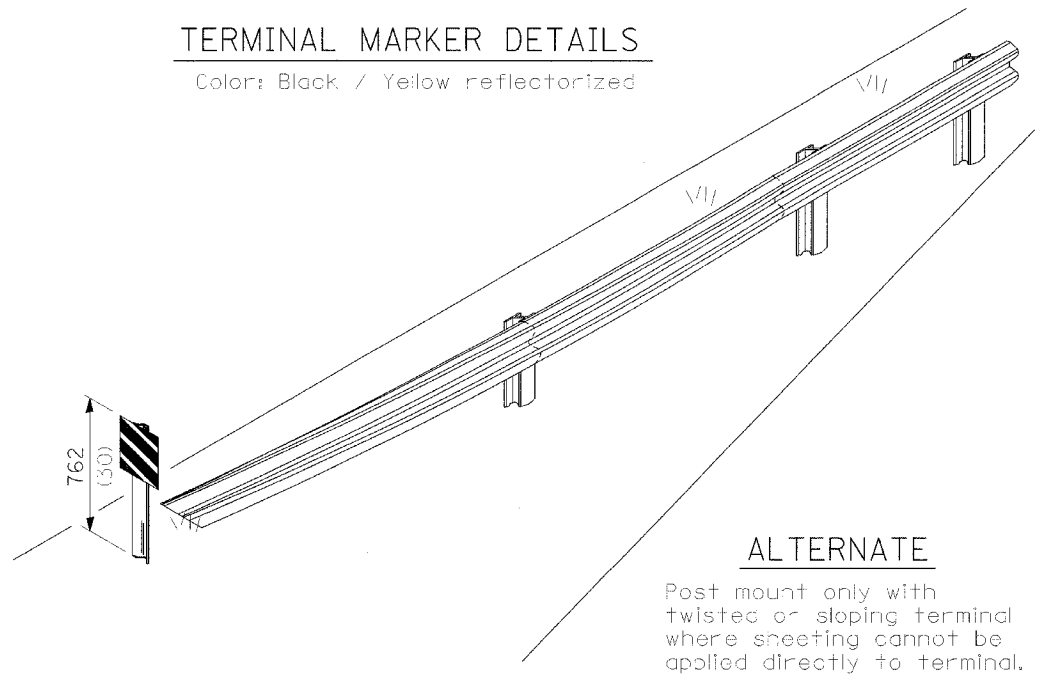

ALTERNATE
Post mount only with twisted or sloping terminal where sheeting cannot be applied directly to terminal.

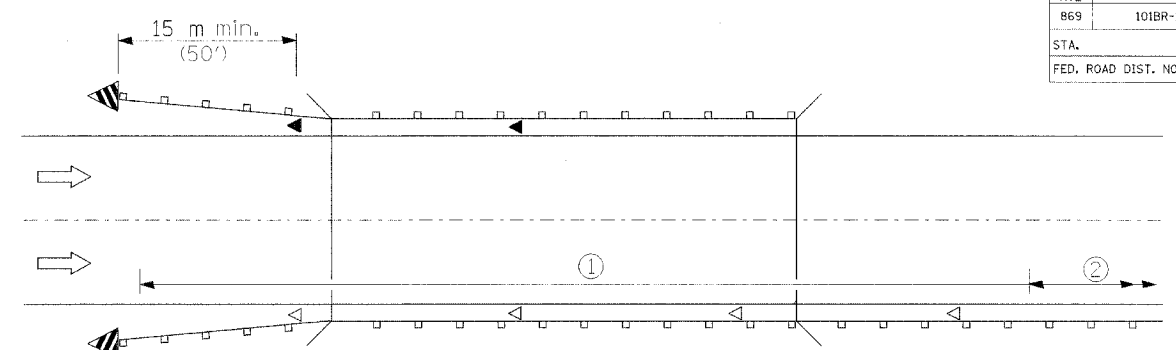

- ① Spacing 24 m (80 ft.) max. for first 122 m (400 ft.) or curve spacing shown in Standard 635001, whichever is less (min. 4 reflectors regardless of length).
- ② After 122 m (400 ft.), transition to normal delineator spacing shown in Standard 635001, and continue as required.

ONE-WAY TRAFFIC

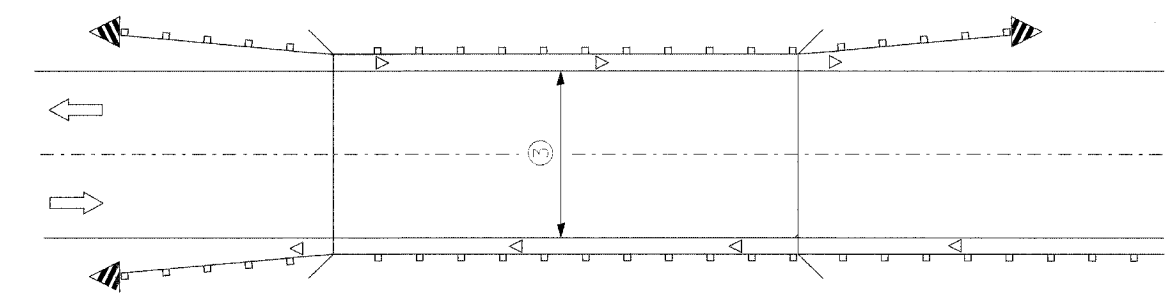

- ③ Bidirectional silver/silver should be used in lieu of monodirectional silver on both sides of two-lane bridges where the pavement is less than 610 (24) wider than the pavement approaching the bridge.

- ◁ Monodirectional silver
- ◄ Monodirectional amber
- ◄◄ Terminal Marker - Black/Yellow Left or Right as appropriate

TWO-WAY TRAFFIC

GUARDRAIL / BARRIER WALL / BRIDGE RAIL REFLECTORS

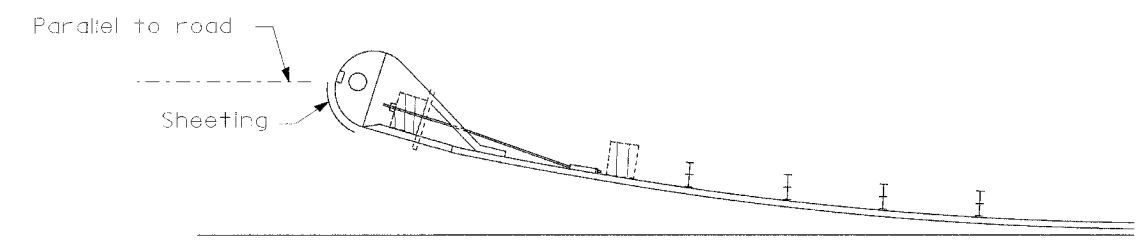

SHEETING POSITION: CASE II

All dimensions are in millimeters (inches) unless otherwise shown.

REFLECTOR AND TERMINAL MARKER PLACEMENT

DETAIL