

STATE OF ILLINOIS
DEPARTMENT OF TRANSPORTATION

ROUTE NO.	SECTION	COUNTY	SHEET NO.	SHEET	SHEET NO. 21 OF 31 SHEETS
FAP 360	*	KANE	41	31	
FED. ROAD DIST. NO. 7		ILLINOIS	FED. AID PROJECT		Contract # 83951 * 06-00214-07-BR

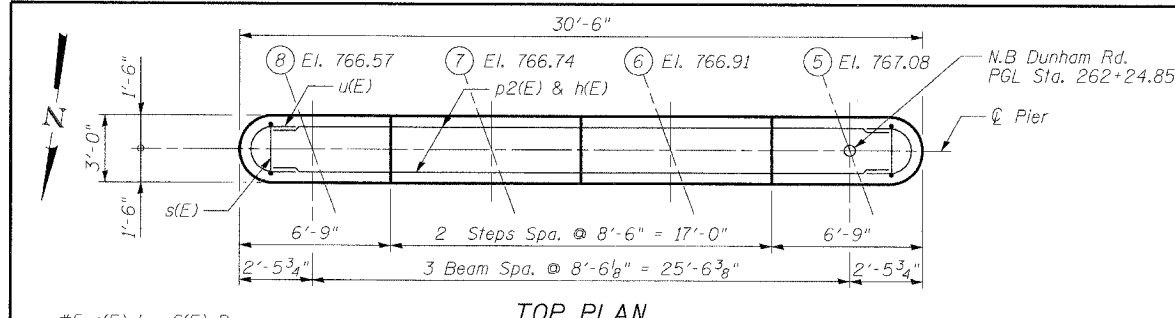

TOP PLAN

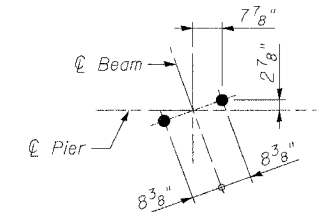

ANCHOR BOLT LAYOUT

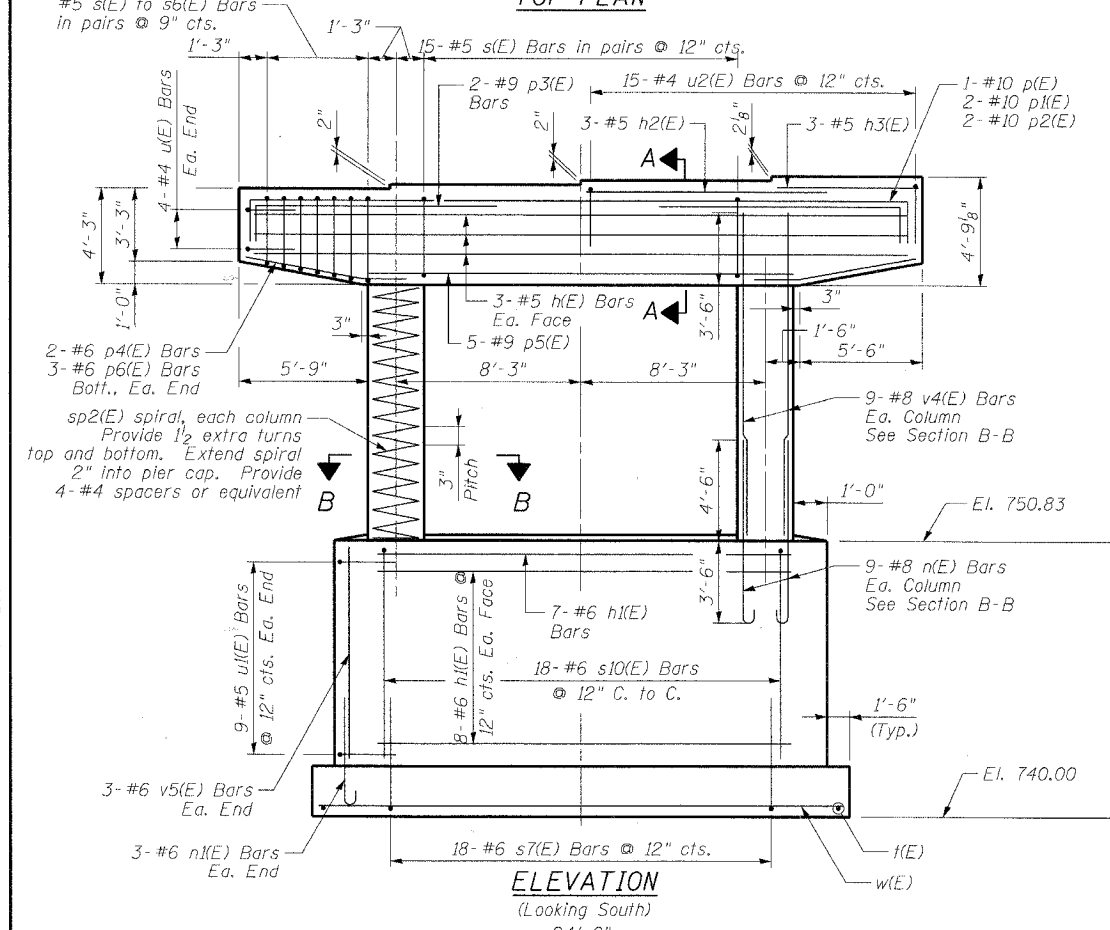

ELEVATION
(Looking South)

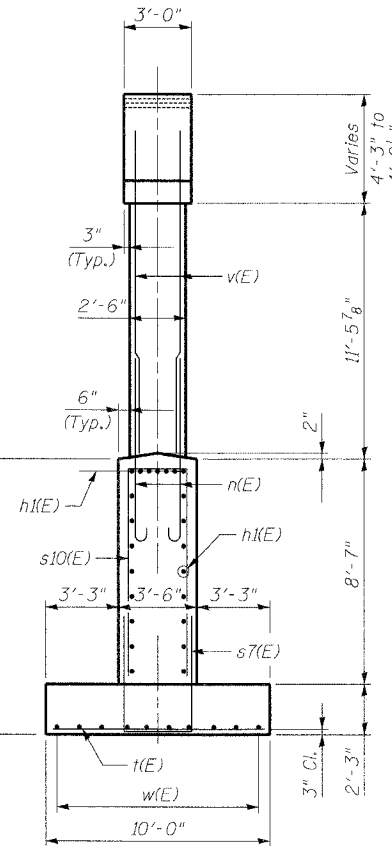

END VIEW

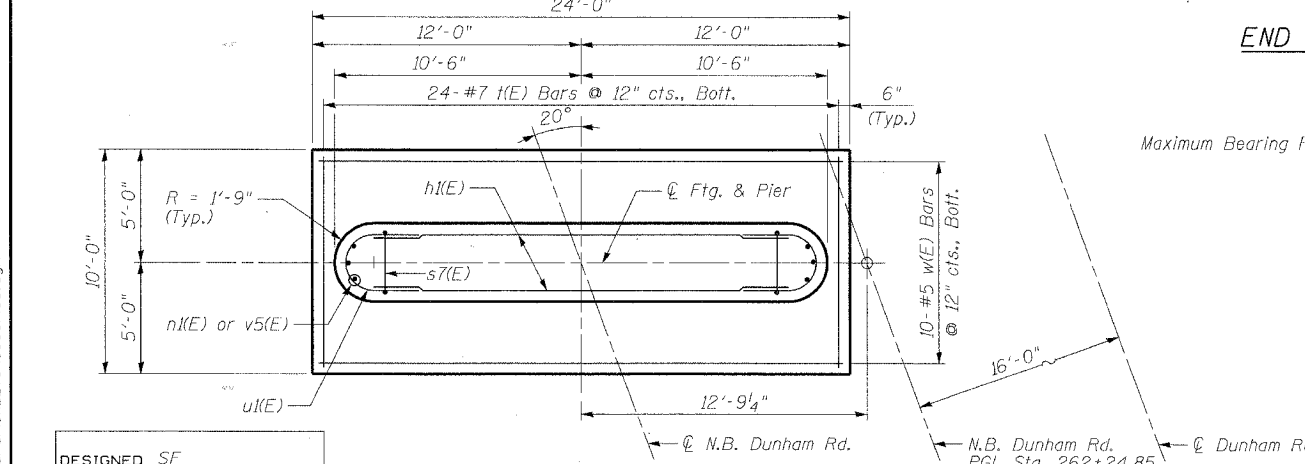

FOOTING PLAN

DESIGNED	SF
CHECKED	BAK
DRAWN	MTR
CHECKED	SF

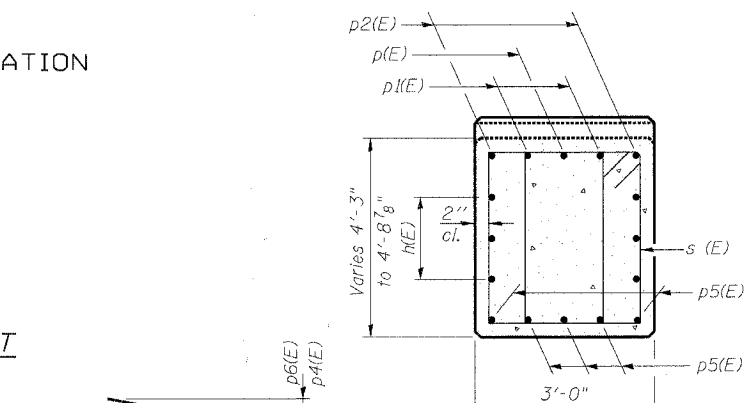

SECTION A-A

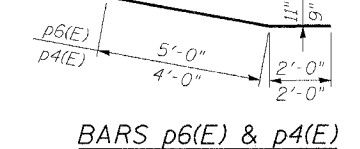

BARS p6(E) & p4(E)

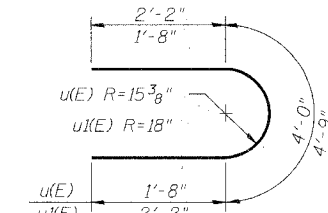

BARS u(E) & u1(E)

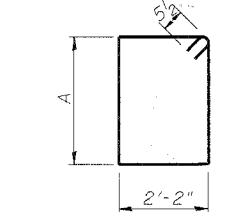

BARS s(E) Thru s6(E)

Bar	A
s(E)	3'-11"
s1(E)	3'-10"
s2(E)	3'-8 1/4"
s3(E)	3'-6 3/4"
s4(E)	3'-5"
s5(E)	3'-3 1/4"
s6(E)	3'-1 3/4"

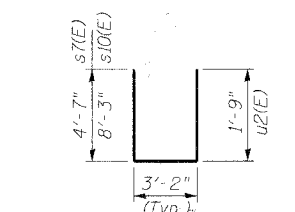

BARS s7(E), s10(E)
& u2(E)

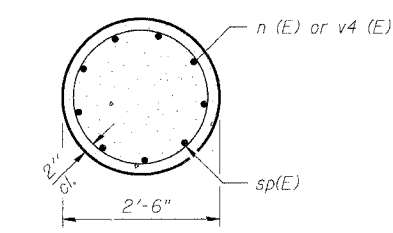

SECTION B-B

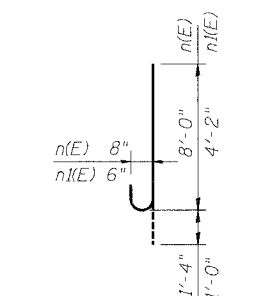

BARS n(E) & n1(E)

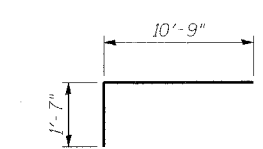

BAR p3(E)

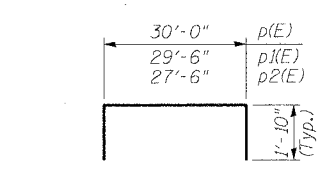

BARS p(E) Thru p2(E)

BILL OF MATERIAL

Bar	No.	Size	Length	Shape
h(E)	6	#5	27'-6"	—
h1(E)	23	#6	18'-0"	—
h2(E)	3	#5	10'-6"	—
h3(E)	3	#5	5'-1"	—
n(E)	18	#8	9'-4"	U
n1(E)	6	#6	5'-2"	U
p(E)	1	#10	33'-8"	U
p1(E)	2	#10	33'-2"	U
p2(E)	2	#10	31'-2"	U
p3(E)	4	#9	12'-4"	U
p4(E)	4	#6	6'-0"	U
p5(E)	5	#9	18'-0"	U
p6(E)	6	#6	7'-0"	U
s(E)	34	#5	13'-1"	□
s1(E)	4	#5	12'-11"	□
s2(E)	4	#5	12'-7 1/2"	□
s3(E)	4	#5	11'-9"	□
s4(E)	4	#5	12'-1"	□
s5(E)	4	#5	11'-9 1/2"	□
s6(E)	4	#5	11'-6 1/2"	□
s7(E)	18	#6	12'-4"	U
s10(E)	18	#6	19'-8"	U
sp2(E)	2	#3	12'-3"	W
u(E)	8	#4	7'-4"	U
u1(E)	18	#5	9'-1"	U
u2(E)	15	#4	6'-8"	U
v4(E)	18	#8	15'-0"	—
v5(E)	6	#6	8'-3"	—
w(E)	10	#5	23'-8"	—
h(E)	24	#7	9'-8"	—
Structure Excavation	Cu. Yd.	189		
Concrete Structures	Cu. Yd.	61.3		
Reinforcement Bars, Epoxy Coated	Pound	6,130		

** Length is height of spiral.
Notes:
Space reinforcement in cap to miss anchor bolts.
Four steps monolithically with cap.

PIER 1 DETAILS - N.B.
DUNHAM ROAD OVER
THE CC&P RAILROAD
SECTION 06-00214-07-BR
KANE COUNTY
STATION 262+90.93

STR. NO. 045-3169 (NB) / 045-3170 (SB)

BOWMAN, BARRETT & ASSOCIATES INC
CONSULTING ENGINEERS
Chicago, Illinois
312.228.0100
www.bbainc.com
Job No. 896

6:57:18 PM 10/11/2007 S:\896\CADD\Structural\SHEETS\896SP103.dgn