

STATE OF ILLINOIS
DEPARTMENT OF TRANSPORTATION

ROUTE NO.	SECTION	COUNTY	SHEET NO.	SHEET	SHEET NO. 25 OF 31 SHEETS
FAP 360	*	KANE	41	35	
FED. ROAD DIST. NO. 7		ILLINOIS	FED. AID PROJECT		Contract # 83951 * 06-00214-07-BR

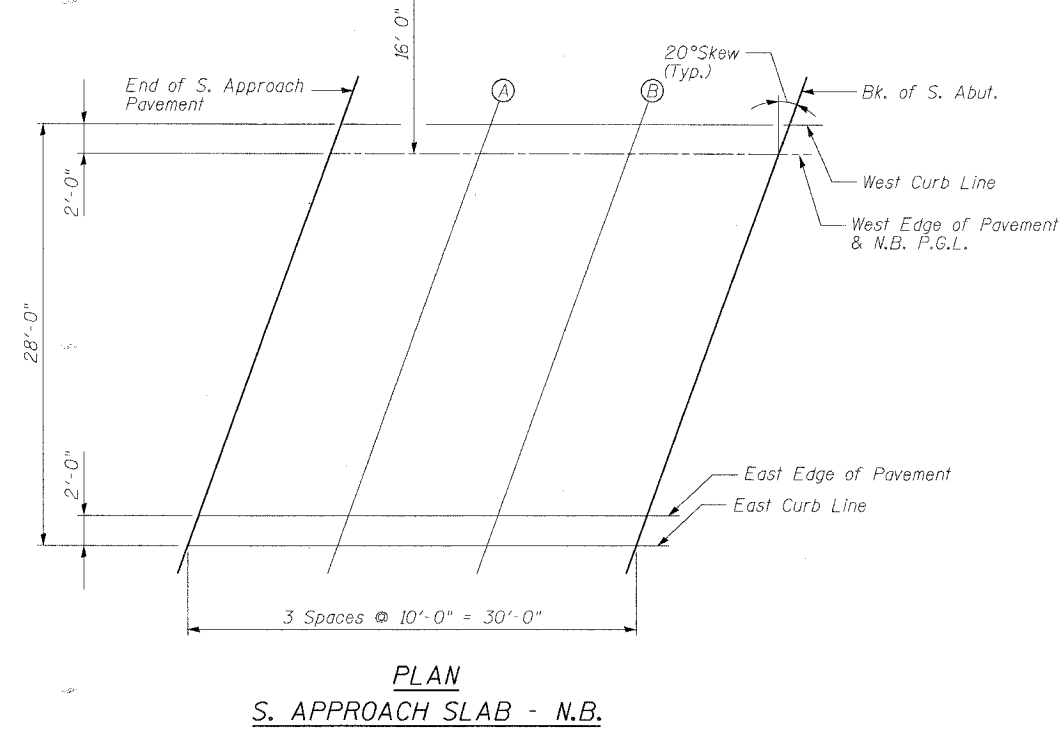
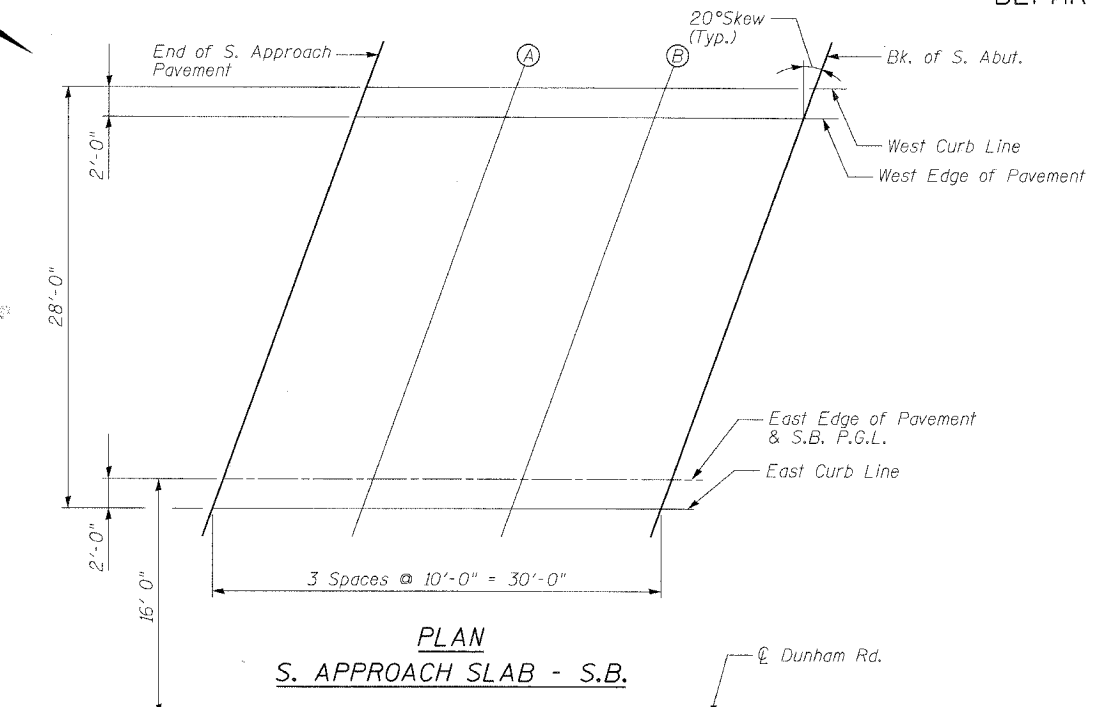

S. APPROACH SLAB S.B. LANES

WEST CURB LINE

Location	Station	Offset	Theoretical Grade Elevations
End S. Appr. Pav't.	261+88.03	-42.00	770.36
A	261+98.03	-42.00	770.42
B	262+08.03	-42.00	770.47
Bk. S. Abut.	262+18.03	-42.00	770.51

WEST EDGE OF PAVEMENT

Location	Station	Offset	Theoretical Grade Elevations
End S. Appr. Pav't.	261+87.30	-40.00	770.39
A	261+97.30	-40.00	770.46
B	262+07.30	-40.00	770.51
Bk. S. Abut.	262+17.30	-40.00	770.55

EAST EDGE OF PAVEMENT & S.B. P.G.L.

Location	Station	Offset	Theoretical Grade Elevations
End S. Appr. Pav't.	261+78.57	-16.00	770.81
A	261+88.57	-16.00	770.88
B	261+98.57	-16.00	770.94
Bk. S. Abut.	262+08.57	-16.00	770.99

EAST CURB LINE

Location	Station	Offset	Theoretical Grade Elevations
End S. Appr. Pav't.	261+77.84	-14.00	770.85
A	261+87.84	-14.00	770.92
B	261+97.84	-14.00	770.98
Bk. S. Abut.	262+07.84	-14.00	771.03

S. APPROACH SLAB N.B. LANES

WEST CURB LINE

Location	Station	Offset	Theoretical Grade Elevations
End S. Appr. Pav't.	261+37.08	14.00	770.45
A	261+47.08	14.00	770.56
B	261+57.08	14.00	770.66
Bk. S. Abut.	261+67.08	14.00	770.76

WEST EDGE OF PAVEMENT & N.B. P.G.L.

Location	Station	Offset	Theoretical Grade Elevations
End S. Appr. Pav't.	261+36.35	16.00	770.40
A	261+46.35	16.00	770.51
B	261+56.35	16.00	770.62
Bk. S. Abut.	261+66.35	16.00	770.71

EAST EDGE OF PAVEMENT

Location	Station	Offset	Theoretical Grade Elevations
End S. Appr. Pav't.	261+27.61	40.00	769.81
A	261+37.61	40.00	769.93
B	261+47.61	40.00	770.05
Bk. S. Abut.	261+57.61	40.00	770.15

EAST CURB LINE

Location	Station	Offset	Theoretical Grade Elevations
End S. Appr. Pav't.	261+26.88	42.00	769.76
A	261+36.88	42.00	769.88
B	261+46.88	42.00	770.00
Bk. S. Abut.	261+56.88	42.00	770.10

DESIGNED	SLV
CHECKED	BAK
DRAWN	MTR
CHECKED	SF

BOWMAN, BARRETT & ASSOCIATES INC
CONSULTING ENGINEERS
Chicago, Illinois
312.228.0100
www.bbandainc.com
Job No. 896

TOP OF SOUTH APPROACH
SLAB ELEVATIONS
DUNHAM ROAD OVER
THE CC&P RAILROAD
SECTION 06-00214-07-BR
KANE COUNTY
STATION 262+90.93
STR. NO. 045-3169 (NB) / 045-3170 (SB)

6:52:50 PM 10/11/2007 S:\896\CADD\Structural\Sheets\896SAD01.dgn