

STATE OF ILLINOIS
DEPARTMENT OF TRANSPORTATION

ROUTE NO.	SECTION	COUNTY	TOTAL SHEETS	SHEET NO.	SHEET NO. 26 OF 31 SHEETS
FAP 350	*	KANE	41	36	
FED. ROAD DIST. NO. 7		ILLINOIS	FED. AID PROJECT NO.		Contract # 83951 * 06-00214-07-BR

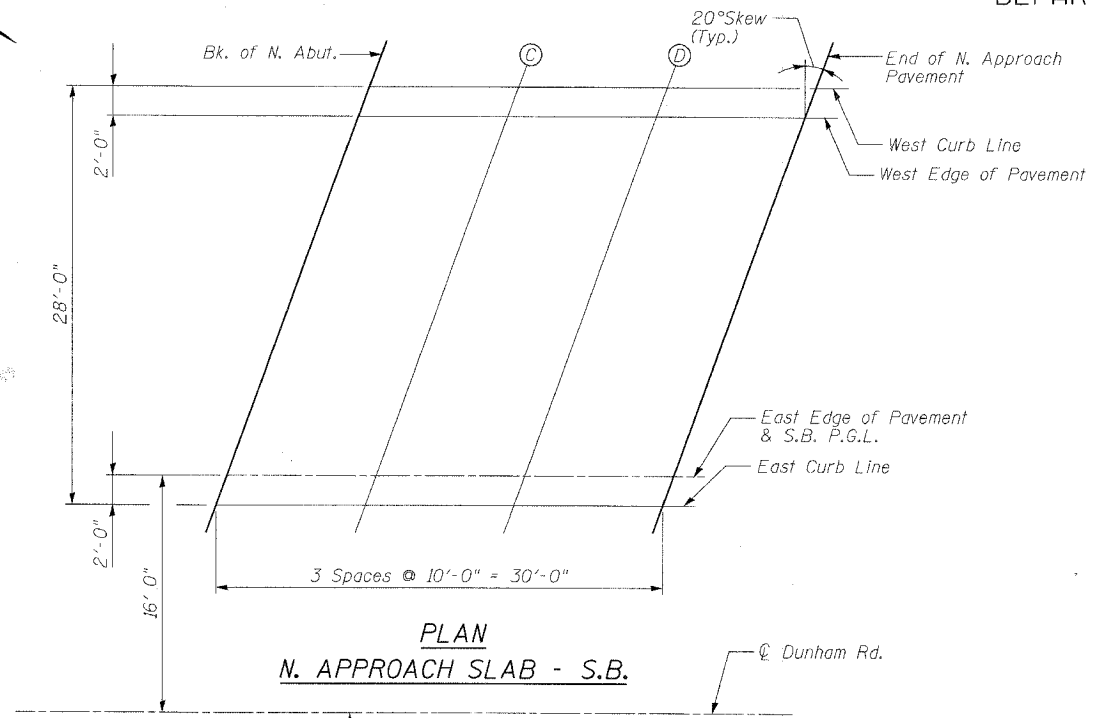

PLAN
N. APPROACH SLAB - S.B.

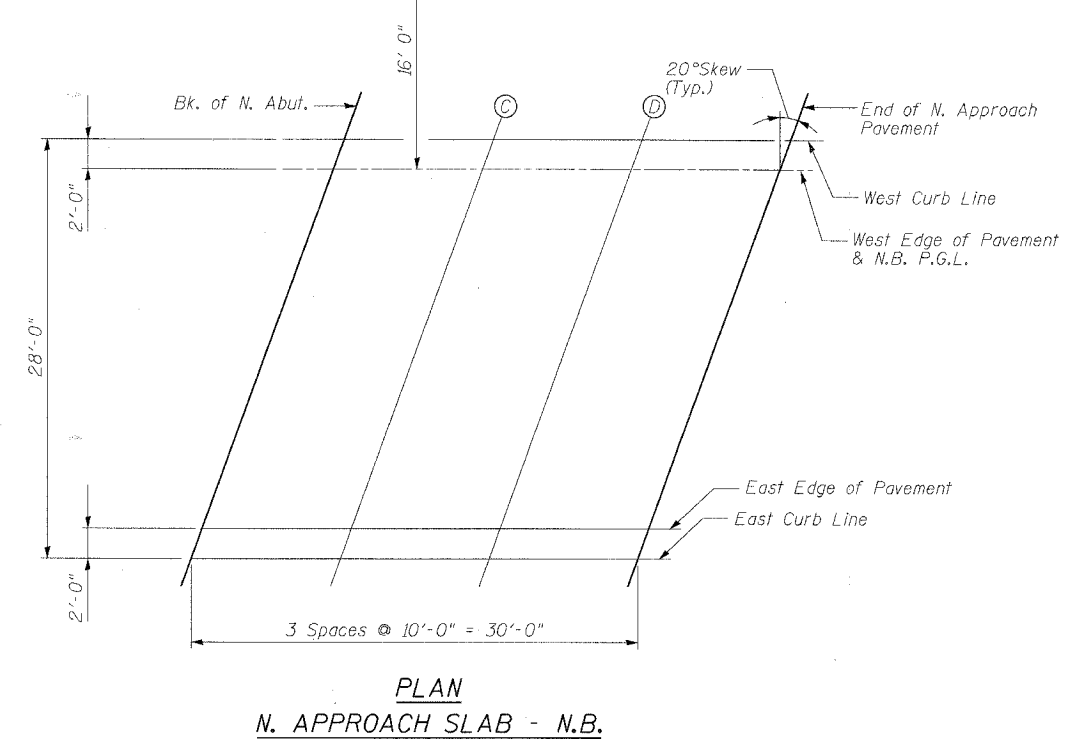

PLAN
N. APPROACH SLAB - N.B.

N. APPROACH SLAB S.B. LANES

WEST CURB LINE

Location	Station	Offset	Theoretical Grade Elevations
Bk. N. Abut.	264+24.87	-42.00	768.99
C	264+34.87	-42.00	768.81
D	264+44.87	-42.00	768.61
End N. Appr. Pav't.	264+54.87	-42.00	768.40

WEST EDGE OF PAVEMENT

Location	Station	Offset	Theoretical Grade Elevations
Bk. N. Abut.	264+24.14	-40.00	769.05
C	264+34.14	-40.00	768.86
D	264+44.14	-40.00	768.66
End N. Appr. Pav't.	264+54.14	-40.00	768.46

EAST EDGE OF PAVEMENT & S.B. P.G.L.

Location	Station	Offset	Theoretical Grade Elevations
Bk. N. Abut.	264+15.40	-16.00	769.68
C	264+25.40	-16.00	769.50
D	264+35.40	-16.00	769.32
End N. Appr. Pav't.	264+45.40	-16.00	769.12

EAST CURB LINE

Location	Station	Offset	Theoretical Grade Elevations
Bk. N. Abut.	264+14.67	-14.00	769.73
C	264+24.67	-14.00	769.56
D	264+34.67	-14.00	769.37
End N. Appr. Pav't.	264+44.67	-14.00	769.17

N. APPROACH SLAB N.B. LANES

WEST CURB LINE

Location	Station	Offset	Theoretical Grade Elevations
Bk. N. Abut.	263+73.91	14.00	770.34
C	263+83.91	14.00	770.21
D	263+93.91	14.00	770.07
End N. Appr. Pav't.	264+03.91	14.00	769.91

WEST EDGE OF PAVEMENT & N.B. P.G.L.

Location	Station	Offset	Theoretical Grade Elevations
Bk. N. Abut.	263+73.18	16.00	770.31
C	263+83.18	16.00	770.18
D	263+93.18	16.00	770.04
End N. Appr. Pav't.	264+03.18	16.00	769.88

EAST EDGE OF PAVEMENT

Location	Station	Offset	Theoretical Grade Elevations
Bk. N. Abut.	263+64.45	40.00	769.94
C	263+74.45	40.00	769.82
D	263+84.45	40.00	769.68
End N. Appr. Pav't.	263+94.45	40.00	769.54

EAST CURB LINE

Location	Station	Offset	Theoretical Grade Elevations
Bk. N. Abut.	263+63.72	42.00	769.91
C	263+73.72	42.00	769.79
D	263+83.72	42.00	769.65
End N. Appr. Pav't.	263+93.72	42.00	769.51

DESIGNED SLV
CHECKED BAK
DRAWN MTR
CHECKED SF

BOWMAN, BARRETT & ASSOCIATES INC.
CONSULTING ENGINEERS
Chicago, Illinois
312.228.0100
www.bbandainc.com
Job No. 896

TOP OF NORTH APPROACH
SLAB ELEVATIONS
DUNHAM ROAD OVER
THE CC&P RAILROAD
SECTION 06-00214-07-BR
KANE COUNTY
STATION 262+90.93
STR. NO. 045-3169 (NB) / 045-3170 (SB)

6:53:06 PM

10/11/2007

S:\896\CADD\STRUCTURAL\SHEETS\896SAD02.dgn