

DETAIL OF PRECAST CONCRETE BOX CULVERT END SECTION

F.A.P. RTE.	SECTION	COUNTY	TOTAL SHEETS	SHEET NO.
969	1101VB1	FRANKLIN	--	19
STA.	TO STA.			
FED. ROAD DIST. NO.	ILLINOIS	FED. AID PROJECT		
CONTRACT NO. 98821				

DIMENSIONS **

SPAN X RISE	T (INCHES)	A (FT.-IN.)	B (FT.-IN.)	C (INCHES)	E (FT.-IN.)	F (FT.-IN.)	G (FT.-IN.)	H (FT.-IN.)	SLOPE (X:Y)
2' X 2'	4	2-8	2-8	4	3-0	3-0	1-0	1-0	3:1
3' X 2'	4	3-8	2-8	4	3-0	3-0	1-0	1-0	3:1
3' X 3'	4	3-8	3-8	4	2-0	4-0	1-8	1-4	3:1
4' X 2'	5	4-10	2-10	5	3-0	3-0	1-0	1-0	3:1
4' X 3'	5	4-10	3-10	5	2-0	4-0	1-8	1-4	3:1
4' X 4'	5	4-10	4-10	5	2-0	4-0	2-0	2-0	2:1
5' X 2'	6	6-0	3-0	6	3-0	3-0	1-0	1-0	3:1
5' X 3'	6	6-0	4-0	6	2-0	4-0	1-8	1-4	3:1
5' X 4'	6	6-0	5-0	6	2-0	4-0	2-0	2-0	2:1
5' X 5'	6	6-0	6-0	6					
6' X 2'	7	7-2	3-2	7	3-0	3-0	1-0	1-0	3:1
6' X 3'	7	7-2	4-2	7	2-0	4-0	1-8	1-4	3:1
6' X 4'	7	7-2	5-2	7	2-0	4-0	2-0	2-0	2:1
6' X 5'	7	7-2	6-2	7	2-0	4-0	3-0	2-0	2:1
6' X 6'	7	7-2	7-2	7	2-0	4-0	4-0	2-0	2:1
7' X 4'	8	8-4	5-4	8	2-0	4-0	2-0	2-0	2:1
7' X 5'	8	8-4	6-4	8					
7' X 6'	8	8-4	7-4	8					
7' X 7'	8	8-4	8-4	8					
8' X 4'	8	9-4	5-4	8	2-0	4-0	2-0	2-0	2:1
8' X 5'	8	9-4	6-4	8					
8' X 6'	8	9-4	7-4	8					
8' X 7'	8	9-4	8-4	8					
8' X 8'	8	9-4	9-4	8					
9' X 5'	9	10-6	6-6	9					
9' X 6'	9	10-6	7-6	9					
9' X 7'	9	10-6	8-6	9					
9' X 8'	9	10-6	9-6	9					
9' X 9'	9	10-6	10-6	9					
10' X 5'	10	11-8	6-8	10					
10' X 6'	10	11-8	7-8	10					
10' X 7'	10	11-8	8-8	10					
10' X 8'	10	11-8	9-8	10					
10' X 9'	10	11-8	10-8	10					
10' X 10'	10	11-8	11-8	10					
11' X 4'	11	12-10	5-10	11					
11' X 6'	11	12-10	7-10	11					
11' X 8'	11	12-10	9-10	11					
11' X 10'	11	12-10	11-10	11					
11' X 11'	11	12-10	12-10	11					
12' X 4'	12	14-0	6-0	12					
12' X 6'	12	14-0	8-0	12					
12' X 8'	12	14-0	10-0	12					
12' X 10'	12	14-0	12-0	12					
12' X 12'	12	14-0	14-0	12					

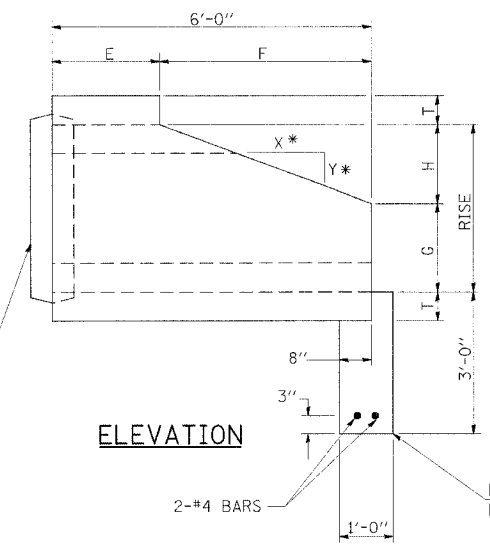

ELEVATION

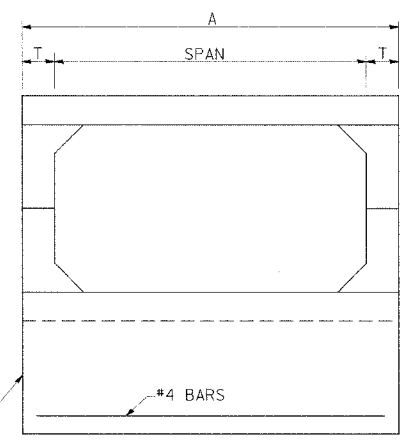

END VIEW

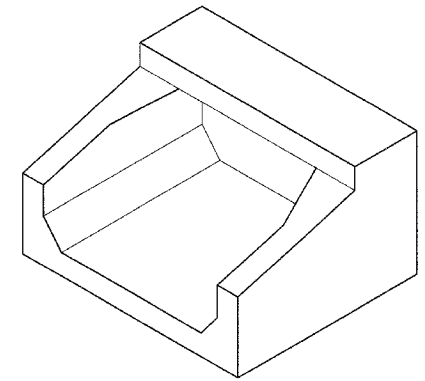

ISOMETRIC

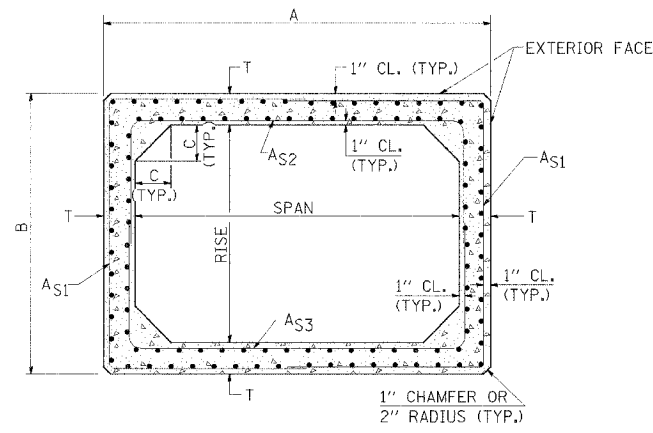

CROSS SECTION

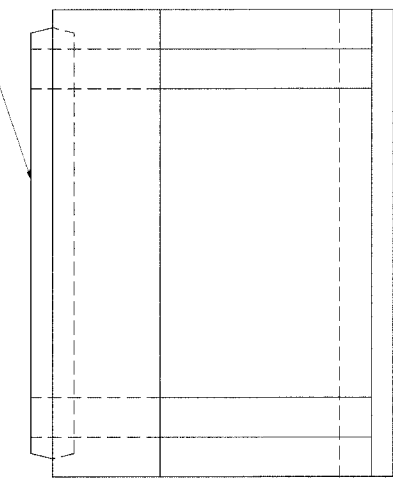

PLAN

GENERAL NOTES

SHOP PLANS FOR THE REINFORCEMENT SHALL BE SUBMITTED IN ACCORDANCE WITH THE REQUIREMENTS OF ARTICLE 504.04 OF THE STANDARD SPECIFICATIONS.

MINIMUM CONCRETE STRENGTH SHALL BE 5000 PSI AFTER 28 DAYS.

THE JOINTS OF THE PRECAST BOX SECTIONS SHALL BE SEALED WITH MASTIC IN ACCORDANCE WITH ARTICLE 1055.01 OF THE STANDARD SPECIFICATIONS FOR ROAD AND BRIDGE CONSTRUCTION.

THE TERMS AS1, AS2, & AS3 DENOTE THE REQUIRED STEEL AREAS FOR REINFORCEMENT AS SPECIFIED IN AASHTO M259. REINFORCEMENT SHALL BE WELDED WIRE FABRIC CONFORMING TO AASHTO M55-81.

** NOTE:

THE DIMENSIONS INDICATED ARE FOR END SECTIONS THAT ARE TO BE USED WITH PRECAST BOX CULVERT SECTIONS DESIGNED FOR 2' OR MORE OF FILL. THE DIMENSIONS MUST BE MODIFIED FOR THE END SECTION TO BE COMPATIBLE WITH PRECAST CULVERT SECTIONS DESIGNED FOR LESS THAN 2' OF FILL.

REVISIONS	
DRAWN	9-8-88
REVISED	3-27-90
REVISED	6-14-94
REVISED	8-16-96
REVISED	01-10-07

STD. 9-50

10/15/2007
 c:\projects\9803603\p1035036.mxd
 03:00:00
 d:\drawing