

FOR INDEX OF SHEETS, STANDARDS AND SIGNATURES, SEE SHEET NO. 2
 FOR SUMMARY OF QUANTITIES, SEE SHEET NO. 4

STATE OF ILLINOIS
 DEPARTMENT OF TRANSPORTATION
 DIVISION OF HIGHWAYS

**PROPOSED
 HIGHWAY PLANS**

F.A.I. 24 (INTERSTATE 24)
 SECTION (64-3B) I-6
 MASSAC COUNTY, ILLINOIS
 McCRACKEN COUNTY, KENTUCKY
 C-99-005-07

ROUTE	SECTION	COUNTY	TOTAL SHEETS	SHEET NO.
F.A.I. 24	*	MASSAC	99	1
FED. ROAD DIST. NO. 7		ILLINOIS		

*(64-3B) I-6
 CONTRACT NO. 98990

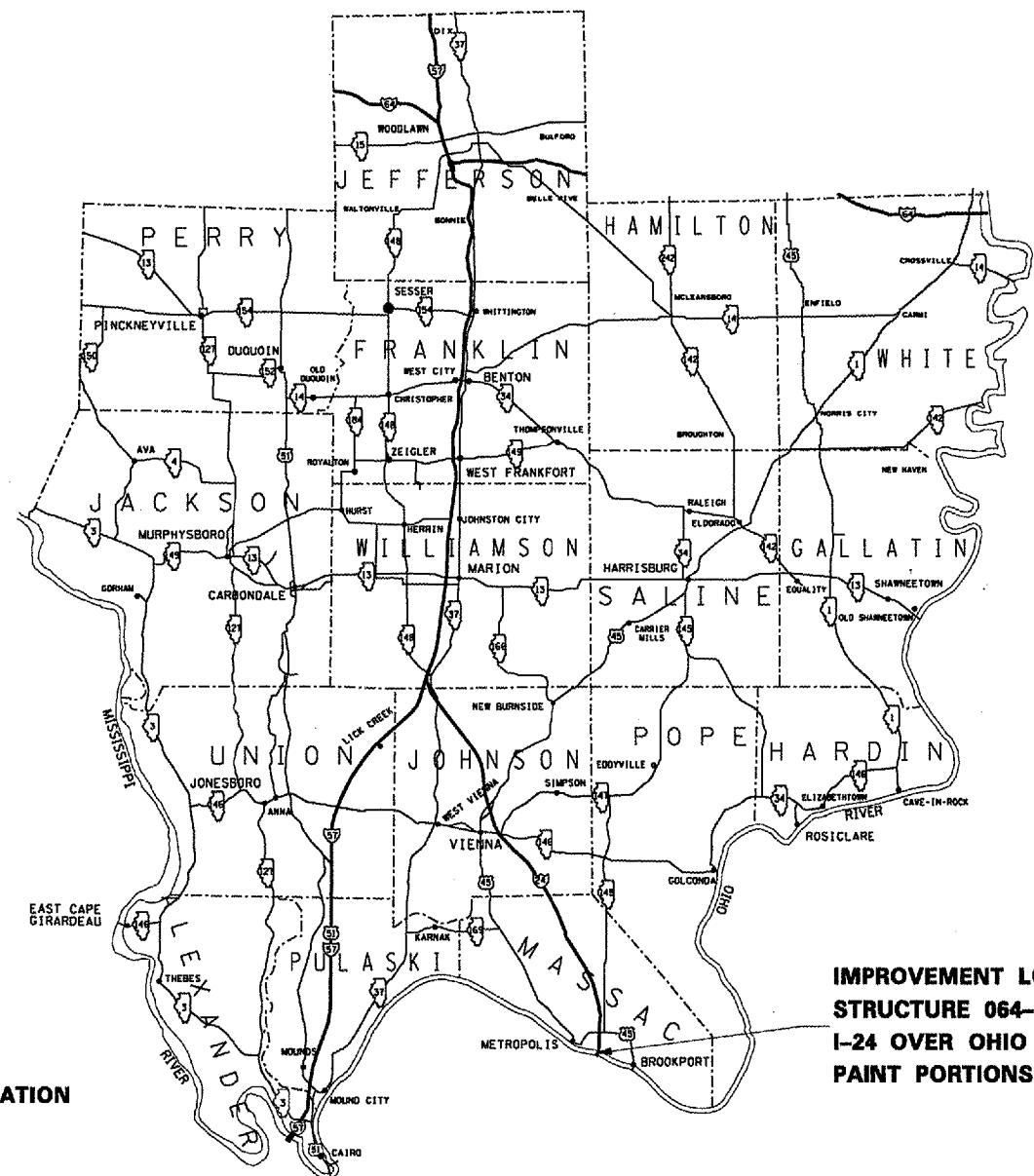
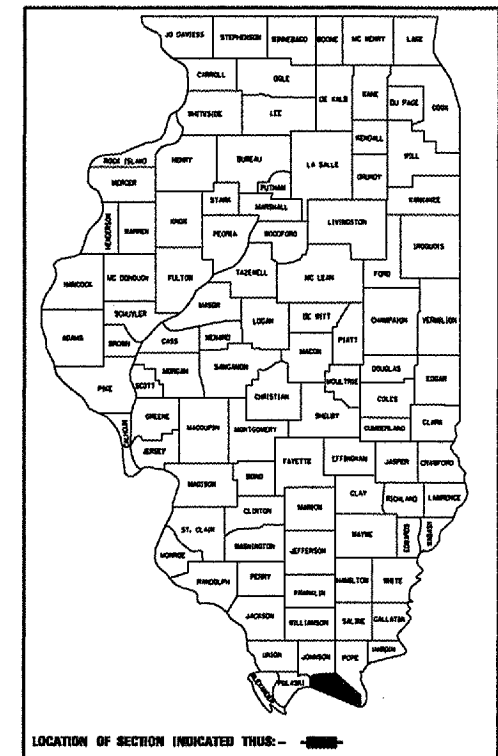

I-24 MILEPOST 38.6
 ADT: 26,100

IMPROVEMENT LOCATION
 STRUCTURE 064-0035
 I-24 OVER OHIO RIVER
 PAINT PORTIONS OF STRUCTURAL STEEL

JOINT UTILITY LOCATION INFORMATION FOR EXCAVATION
 J.U.L.I.E. 1-800-892-0123

CONTRACT NO. 98990

PROJECT ENGINEER: CASEY TECKENBROCK PHONE: (618) 549-2171
 SQUAD LEADER: RITA GAULTNEY CENTREX: 782-4554

STATE OF ILLINOIS
 DEPARTMENT OF TRANSPORTATION
 DIVISION OF HIGHWAYS

SUBMITTED Sept 25 2007
Mary C. Lami
 DEPUTY DIRECTOR OF HIGHWAYS, REGION ENGINEER

Dec 7, 2007
Eric C. Horn
 ENGINEER OF DESIGN AND ENVIRONMENT

Dec 7 2007
Christine M. Reed
 DIRECTOR OF HIGHWAYS, CHIEF ENGINEER

**PRINTED BY THE AUTHORITY
 OF THE STATE OF ILLINOIS**

STATE OF ILLINOIS
DEPARTMENT OF TRANSPORTATION

ROUTE	SECTION	COUNTY	TOTAL SHEETS	SHEET NO.
F.A.I. 24	*	MASSAC	99	2

FED. ROAD DIST. NO. 7 ILLINOIS

*(64-3B) I-6
CONTRACT NO. 98990

INDEX OF SHEETS

<u>SHEET NO.</u>	<u>DESCRIPTION</u>
1	COVER SHEET
2	INDEX OF SHEETS, STANDARDS, SIGNATURES
3	GENERAL NOTES
4	SUMMARY OF QUANTITIES
5	GENERAL ELEVATION SHOWING PAINT LOCATIONS
6	STRUCTURAL STEEL PLAN SHEET REFERENCE
7-49	1968 CONSTRUCTION - FOR INFORMATION ONLY
50, 51	1980 SPLICE PLATE ADDITION - FOR INFORMATION ONLY
52-72	1988 STIFFENING TRUSS ADDITION - FOR INFORMATION ONLY
73-78	1996 TROUGH AND JOINT MODIFICATIONS - FOR INFORMATION ONLY
79-96	2002 BEARINGS AND STRINGER END MODIFICATIONS - FOR INFORMATION ONLY
97-99	ELASTOMERIC DRAIN TROUGH

STANDARDS

701101-01	OFF-ROAD OPERATIONS, MULTILANE, 15' TO 24" FROM PAVEMENT EDGE
701400-02	APPROACH TO LANE CLOSURE, FREEWAY/EXPRESSWAY
701401-04	LANE CLOSURE, FREEWAY/EXPRESSWAY
701901	TRAFFIC CONTROL DEVICES

Prepared By:	<i>Herwin Grammes</i> DISTRICT OPERATIONS ENGINEER
Examined By:	<i>Samuel Clayton</i> ASSISTANT REGIONAL ENGINEER
Examined By:	<i>James Lewis Eng</i> DISTRICT LAND ACQUISITION ENGINEER
Examined By:	<i>Corrie Nelson</i> DISTRICT PROGRAM DEVELOPMENT ENGINEER
Examined By:	<i>Joe Zlaniewicz</i> DISTRICT STUDIES & PLANS ENGINEER
Examined By:	<i>Joseph Leguin</i> DISTRICT CONSTRUCTION ENGINEER
Examined By:	<i>Bruce Seebles</i> DISTRICT MATERIALS ENGINEER
Examined By:	<i>John Smother</i> DISTRICT PROJECT IMPLEMENTATION ENGINEER
Approved By:	<i>May C. Kama</i> DEPUTY DIRECTOR OF HIGHWAYS, REGION ENGINEER
	<i>Sept 13 2007</i> DATE

STATE OF ILLINOIS
DEPARTMENT OF TRANSPORTATION

ROUTE	SECTION	COUNTY	TOTAL SHEETS	SHEET NO.
F.A.I. 24	*	MASSAC	99	3
FED. ROAD DIST. NO. 7	ILLINOIS			

*(64-3B) I-6
CONTRACT NO. 98990

GENERAL NOTES

Cleaning and painting shall conform to the requirements of special provision "Cleaning And Painting Existing Steel Structures". Near White Metal Blast Cleaning - SSPC - SP10 and Paint System 1 - OZ / E / U shall be used, unless otherwise noted.

The color of the final finish coat shall be Light Gray, Munsell No. 10 Y 7 / 1.

SSPC - QP1 and SSPC - QP2 Painting Contractor Certifications are required.

Structural steel shall be ^{cleaned} painted at the following locations and as directed by the Engineer:

At thirteen (13) deck expansion joints, all structural steel below the elevation of the top of the stiffening truss and within five (5) feet of the joint opening shall be ^{cleaned} painted. The out-to-out width is 73'-0". Inspection walks and handrail around the top of piers is included.

At Piers No. 3, 4, 12, and 13, the arches up to eight (8) feet above the deck surface shall be painted.

^{cleaned &} A total of twelve (12) access holes in the arch ties shall be uncovered and interior surfaces ^{cleaned} painted from diaphragm to diaphragm (a length of approximately eleven (11) feet at each hole). The bottom plates shall be painted, and the web plates shall be ^{cleaned &} painted up to a minimum height of six (6) inches. The cover plates shall be ^{cleaned &} painted and re-installed. All debris shall be removed from the arch ties at the hole locations.

^{cleaned &} Power Tool - Commercial Grade cleaning may be used inside the ties. Post-tensioning cables are located inside the arch ties. The Contractor shall protect the cable coatings from any potential damage during the Contractor's operations. The Contractor shall obtain the Engineer's approval of the protection method before beginning work inside the arch ties.

Locations of painting are shown on sheet 5 of 99.

The Contractor shall submit to the Illinois Department of Transportation a work plan that includes a work schedule and containment details for each painting location over water. No work will be permitted prior to approval of the plan by the United States Coast Guard. For questions about the Coast Guard requirements, contact Roger Weibusch at Eighth Coast Guard District, 1222 Spruce Street, St. Louis, Missouri, 63103; telephone (314) 539-3900.

The Contractor is advised that navigational illumination is present on this structure. All cable or conduit is to remain in service. Any cable or conduit which is damaged as a result of the Contractor's operations shall be replaced by the Contractor at the Contractor's expense. Replacement material and methods shall meet or exceed the original specifications for the wiring. Splicing will not be permitted.

The existing structural steel coating contains lead.

At Pier No. 8 under the southbound traffic lanes, the elastomeric drain trough below the expansion joint, 30'-9" in length, shall be replaced according to Article 520 of the Standard Specifications. See sheets 97 - 99 of 99. The cost of all materials, hardware, and labor, and the cost of removal of the existing trough are included in the cost of "Fabric Reinforced Elastomeric Trough" and will not be paid for separately.

Plan dimensions and details relative to existing structure have been taken from existing plans and are subject to nominal construction variations. It shall be the Contractor's responsibility to verify such dimensions and details in the field and make necessary approved adjustments prior to construction or ordering of materials. Such variations shall not be cause for additional compensation for a change in the scope of the work, however, the Contractor will be paid for the quantity actually furnished at the unit price bid for the work.

The elastomeric drain trough at each toothed (finger) expansion joint shall be cleaned of all debris as directed by Engineer. At Pier No. 12, the elastomeric drain trough shall be repaired as directed by the Engineer. This work shall be paid for in accordance with Article 109.04 of the Standard Specifications for Road and Bridge Construction.

STATE OF ILLINOIS
DEPARTMENT OF TRANSPORTATION

CONTRACT NO. 98990

ROUTE	SECTION	COUNTY	TOTAL SHEETS	SHEET NO.
F.A.I. 24	*	MASSAC	99	5

FED. ROAD DIST. NO. 7 ILLINOIS

*(64-3B) I-6

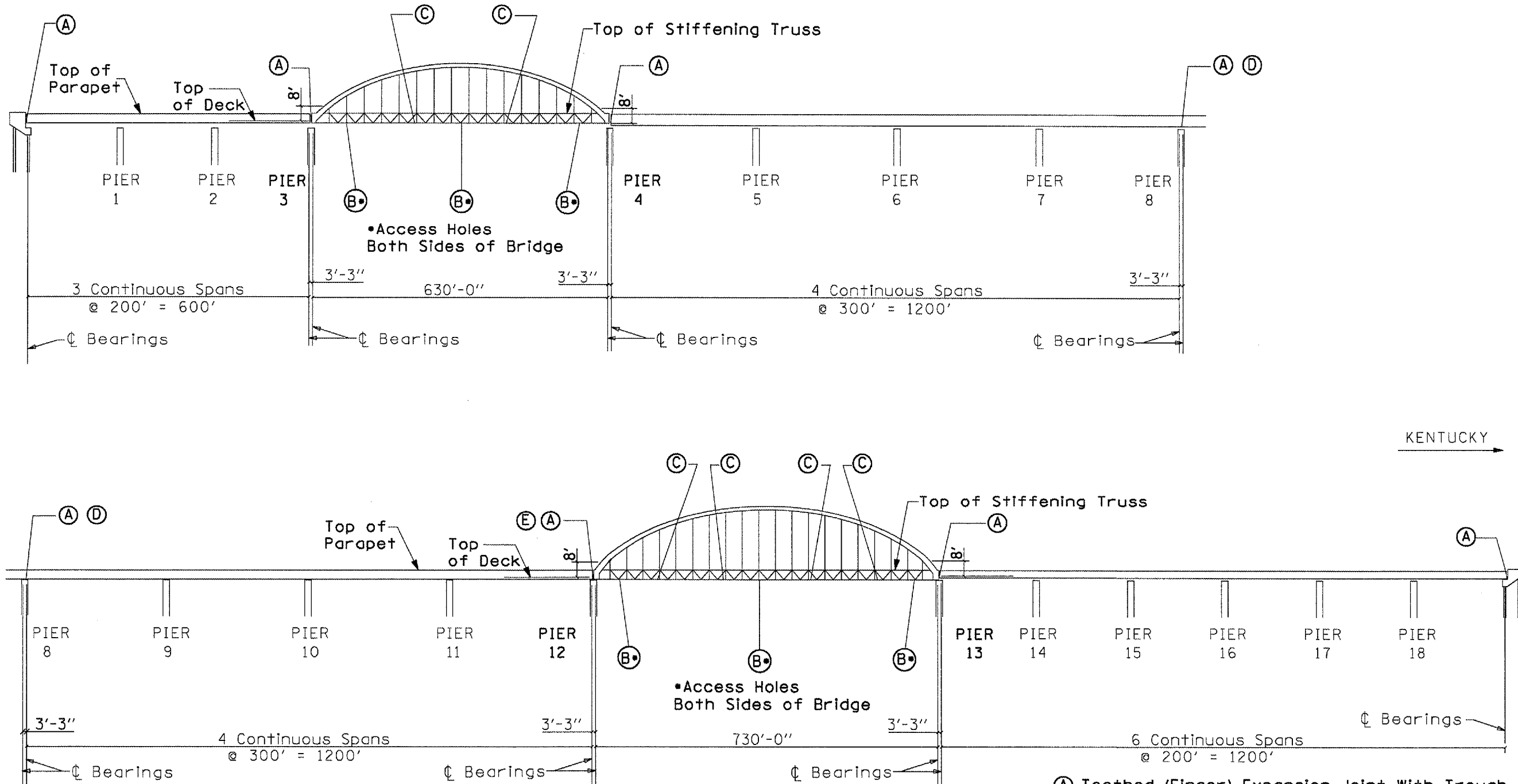

PAINT LOCATIONS

- (A) Toothed (Finger) Expansion Joint With Trough
- (B) Access Hole
- (C) Expansion Joint - Various Types
- (D) Elastomeric Trough Replacement
- (E) Elastomeric Trough Repair

STATE OF ILLINOIS
DEPARTMENT OF TRANSPORTATION

ROUTE	SECTION	COUNTY	TOTAL SHEETS	SHEET NO.
F.A.I. 24	*	MASSAC	99	6
FED. ROAD DIST. NO. 7		ILLINOIS		

*(64-3B) I-6
CONTRACT NO. 98990

NOTE:
SELECTED STRUCTURE CONSTRUCTION DETAILS ARE SHOWN ON SHEETS 7-96 OF 99.
ADDITIONAL CONSTRUCTION DETAILS WILL BE MADE AVAILABLE AT THE CONTRACTOR'S REQUEST.

STRUCTURAL STEEL CONSTRUCTION
FOR INFORMATION ONLY

LOCATION	REFERENCE SHEET NO.
Abutments Toothed (Finger) Joints	16-25, 27-30, 37, 45, 81, 82, 89-92, 95, 96
West Arch Exp. Joints	8, 16-18, 21, 23, 27-36, 39, 41, 42, 51, 54-58, 64-72, 74, 78, 81, 83, 90, 92-94
East Arch Exp. Joints	11-13, 21, 23, 24, 32, 36, 38, 39, 41, 45, 48, 51, 59-72, 74-76, 78, 81, 87, 90, 94
West Arch Toothed (Finger) Exp. Joints	7-9, 16-18, 21-33, 35-37, 39, 42, 44, 45, 49, 57, 58, 67, 71, 72, 74-77, 81-84, 90-93
Pier 8 Toothed (Finger) Exp. Joints	10, 11, 16-18, 21-24, 26-30, 44, 45, 49, 74-77, 85, 90, 94
East Arch Toothed (Finger) Exp. Joints	11-24, 25-30, 32, 35-37, 38-40, 43-45, 49, 62, 63, 67, 71, 72, 81, 82, 86-88, 90, 95
Access Holes	31, 33, 38, 40, 64-66

CONTRACT: 98990
 ROUTE: INTERSTATE 24
 SECTION: (64-3B) I-6
 COUNTY: MASSAC, IL; McCracken, KY
 SHEET 7 OF 99
 FOR INFORMATION ONLY

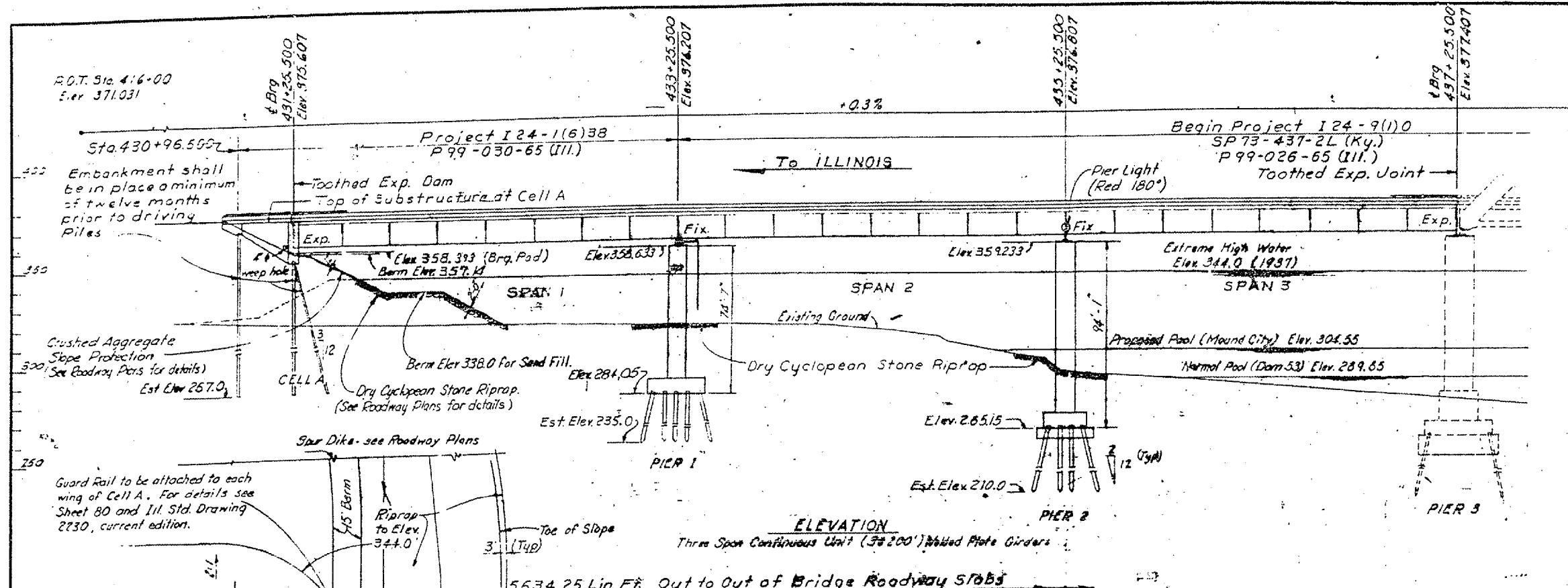

NOTE:
 Cells, Riprap, Pier Substructure, etc.
 are not a part of this contract.

DESIGN LOAD
 HS 20-44 Loading as specified in 1965 AASHTO
 Specifications for Highway Bridges, or other
 loading of two 24 kip axes spaced four feet
 apart, whichever produces the greater stress.

DESIGN ROADWAY
 Two - 30' Roadways with a 2' Median
 and two 8' Brush Curbs.

Elevation Datum: U.S.C. & G.S. 1929 Adjusted
 B.M.: See Roadway Plans, Sheets 2 & 5.

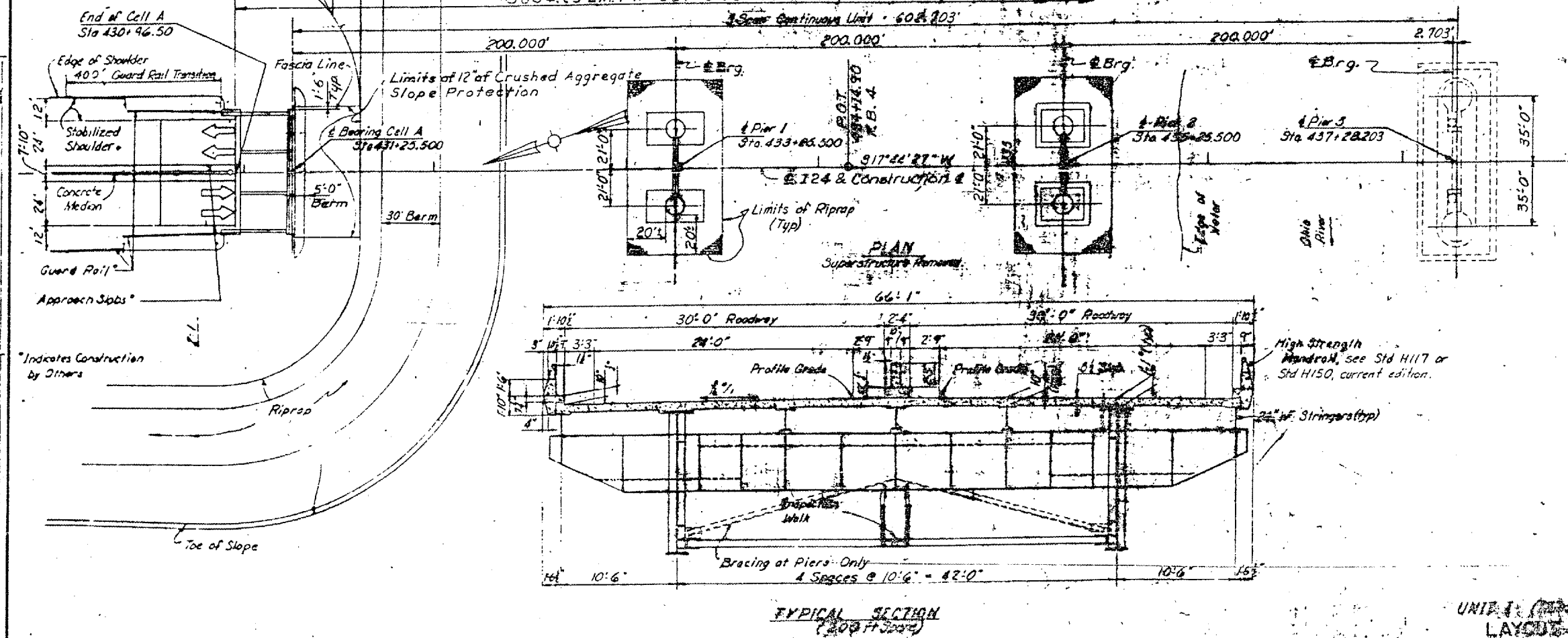

TYPICAL SECTION
 (200 FT LONG)

UNIT 1
 LAYOUT

SHEET 6 OF 21

**KENTUCKY DEPARTMENT OF HIGHWAYS
 ILLINOIS DEPARTMENT OF PUBLIC WORKS
 AND BUILDINGS**

PROJECTS I 24-1(6)38, I 24-9(1)0, I 24-1(6)11
 BRIDGE OVER OHIO RIVER ON I 24
 BETWEEN MASSACREN COUNTY, KENTUCKY
 AND SPASAC COUNTY, ILLINOIS

DRAWN BY: R.B.S.	CHECKED BY: J.L.	DATE: 1/1/61	PROJECT NO. 17431
------------------	------------------	--------------	-------------------

CONTRACT: 98990
 ROUTE: INTERSTATE 24
 SECTION: (64-3B) I-6
 COUNTY: MASSAC, IL; McCracken, KY
 SHEET 8 OF 99
 FOR INFORMATION ONLY

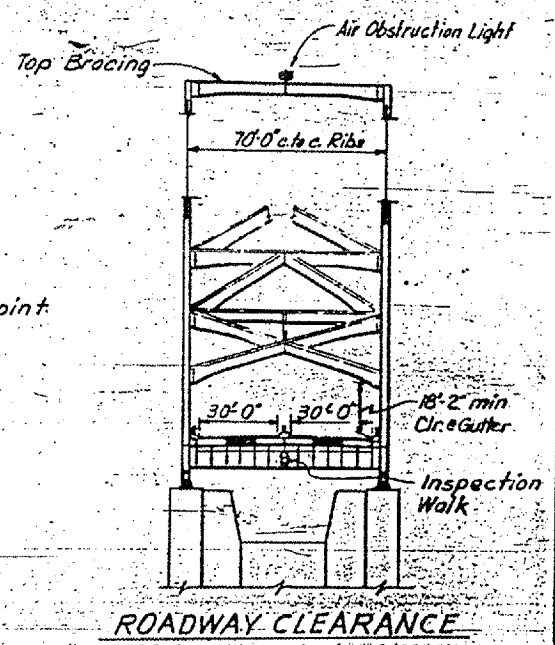
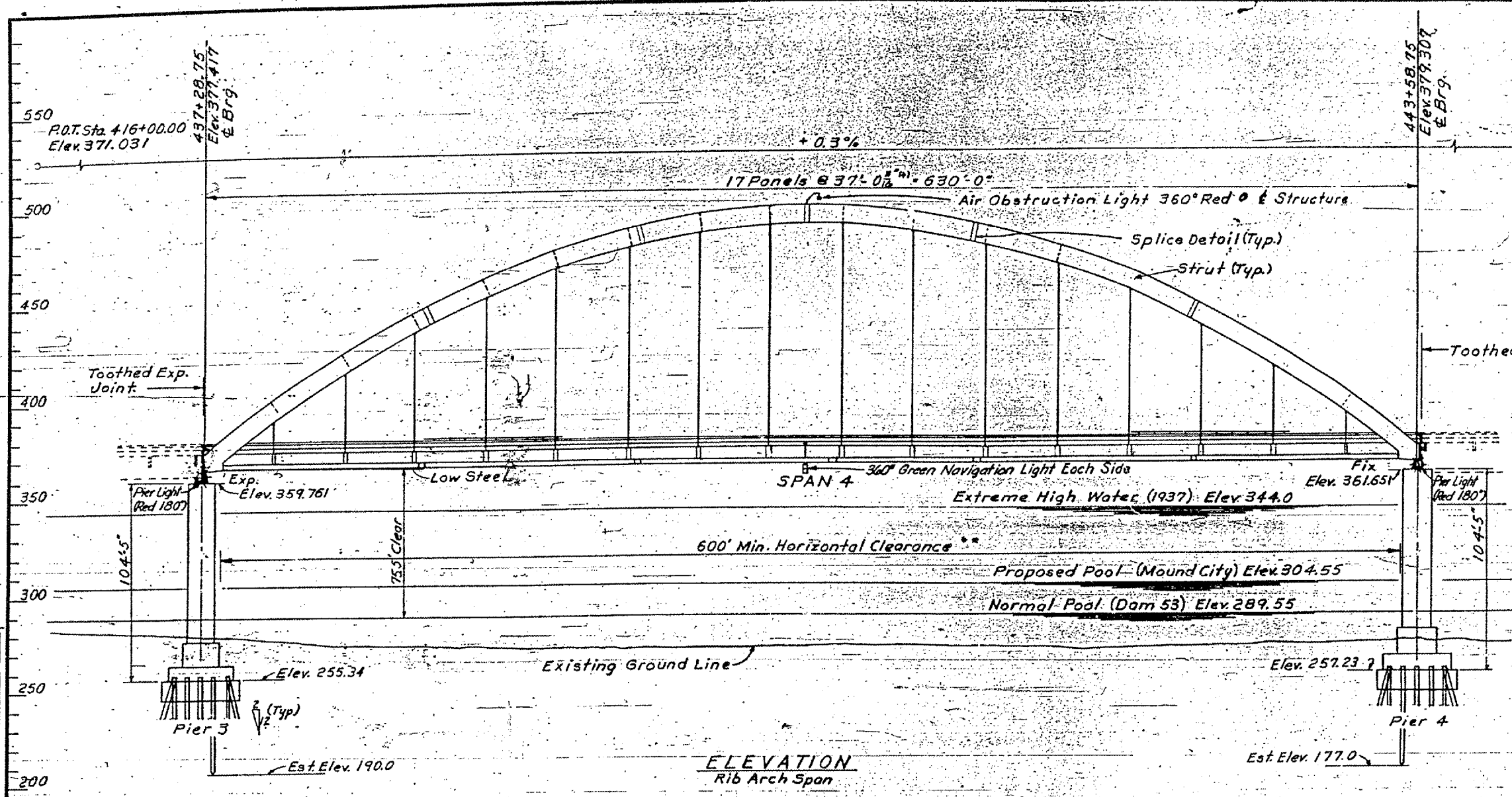

NOTES:
 For Design Load see Sheet No. 6
 * Horizontal Clearance measured perpendicular to Sailing Line.

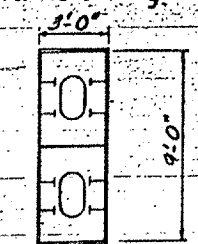

TYPICAL SECTION THROUGH RIB ARCH

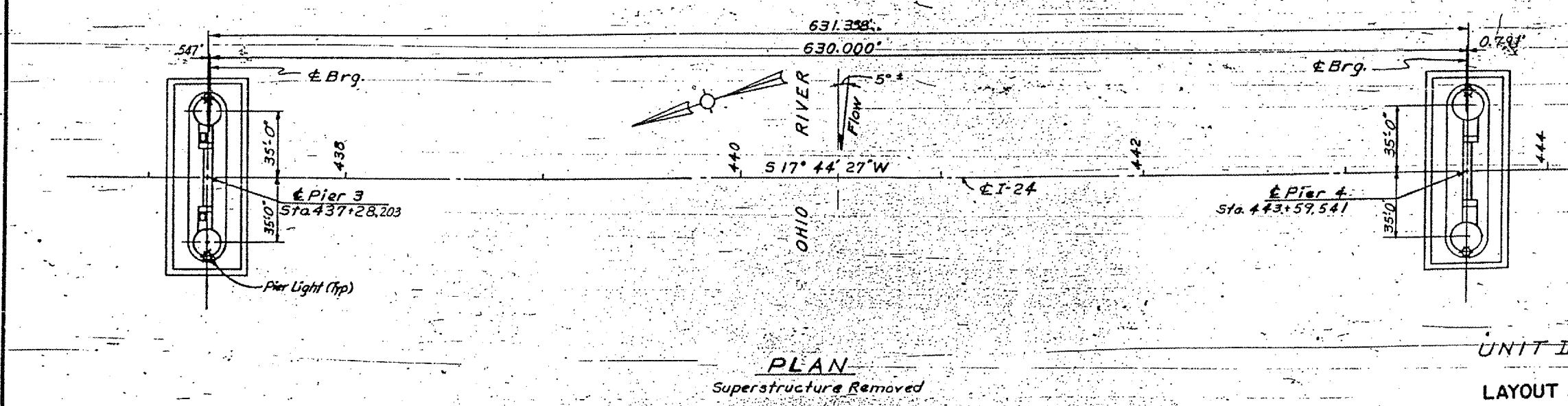

UNIT II
 LAYOUT

KENTUCKY DEPARTMENT OF HIGHWAYS
 ILLINOIS DEPARTMENT OF PUBLIC WORKS
 AND BUILDINGS
 PROJECTS I 24-116138, I 24-91130, I 24-11611
 BRIDGE OVER OHIO RIVER ON I 24
 BETWEEN MACCRACKEN COUNTY, KENTUCKY
 AND MASSAC COUNTY, ILLINOIS

HASLEY & BRIDGES Consulting Engineers File No. 888	DESIGN NUMBER 17471	DRAWING NO. 17471	SHEET 7 OF 99
--	------------------------	----------------------	------------------

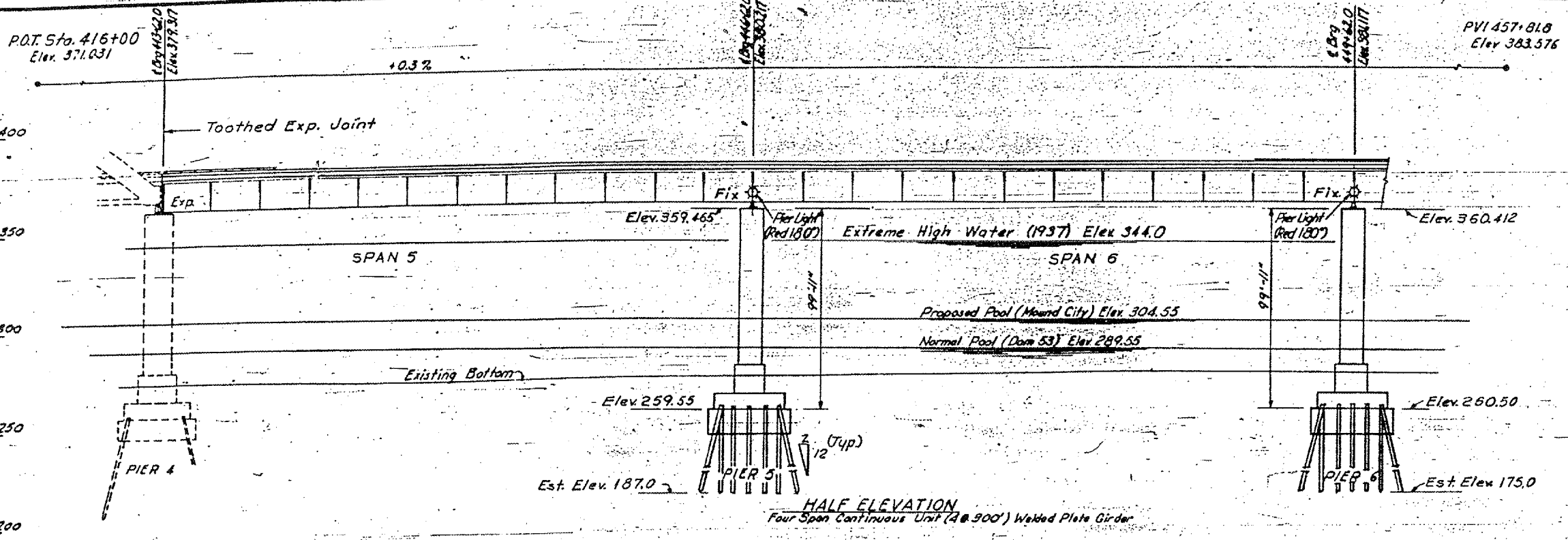

CONTRACT: 98990
 ROUTE: INTERSTATE 24
 SECTION: (64-3B) I-6
 COUNTY: MASSAC, IL; McCRACKEN, KY
 SHEET 9 OF 99
 FOR INFORMATION ONLY

NOTES:
 For Design Load and Design Roadway see
 Sheet NR 6

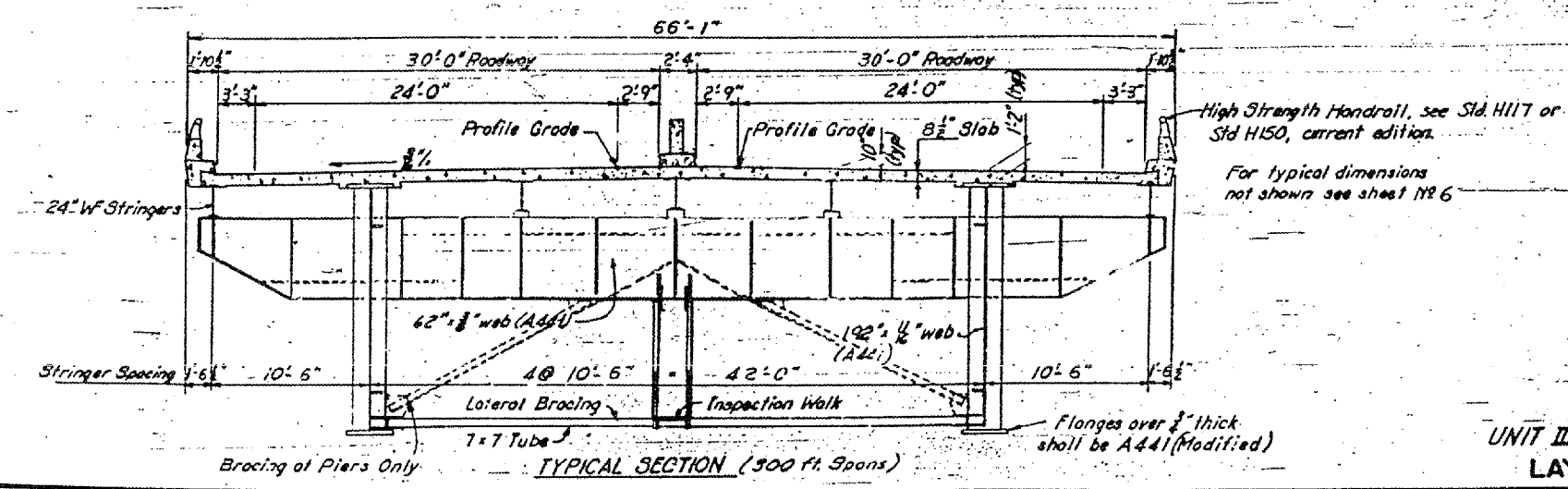
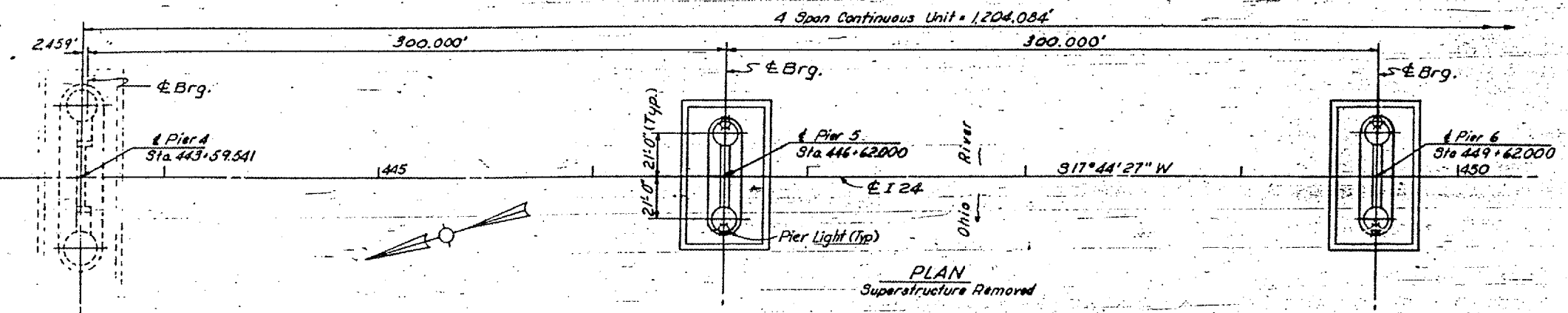

UNIT III (III-Ky)
 LAYOUT

SHEET 8 OF 121

KENTUCKY DEPARTMENT OF HIGHWAYS
ILLINOIS DEPARTMENT OF PUBLIC WORKS
AND BUILDINGS

PROJECTS I 24-116138, I 24-9(110), I 24-116111
 BRIDGE OVER OHIO RIVER ON I 24
 BETWEEN McCRACKEN COUNTY, KENTUCKY
 AND MASSAC COUNTY, ILLINOIS

HAZLE & BIRDA Consulting Engineers P.O. Box 200	BRIDGE NUMBER	DRAWING NO. 17471
---	------------------	-----------------------------

CONTRACT: 98990
 ROUTE: INTERSTATE 24
 SECTION: (64-3B) 1-6
 COUNTY: MASSAC, IL; McCRACKEN, KY
 SHEET 10 OF 99
 FOR INFORMATION ONLY

NOTE
 For Des
 see Sh
 For Typ

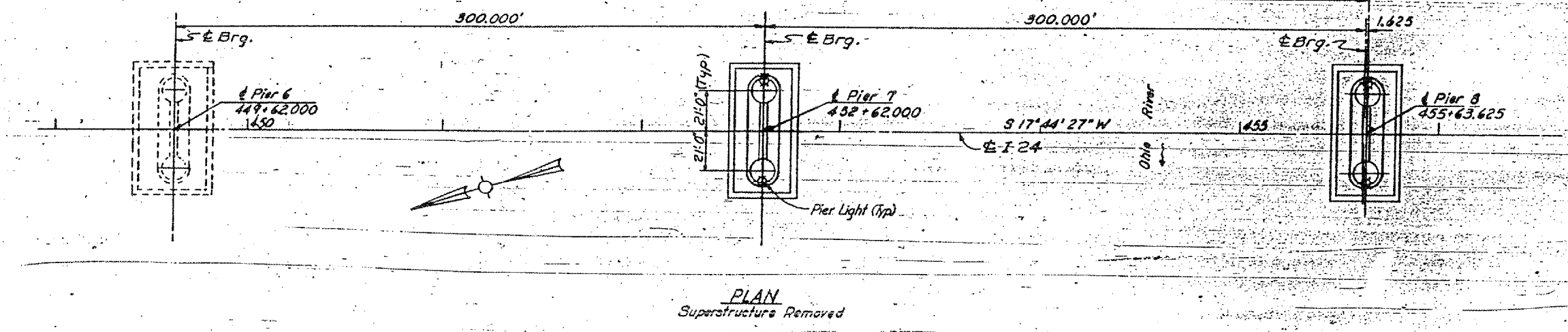
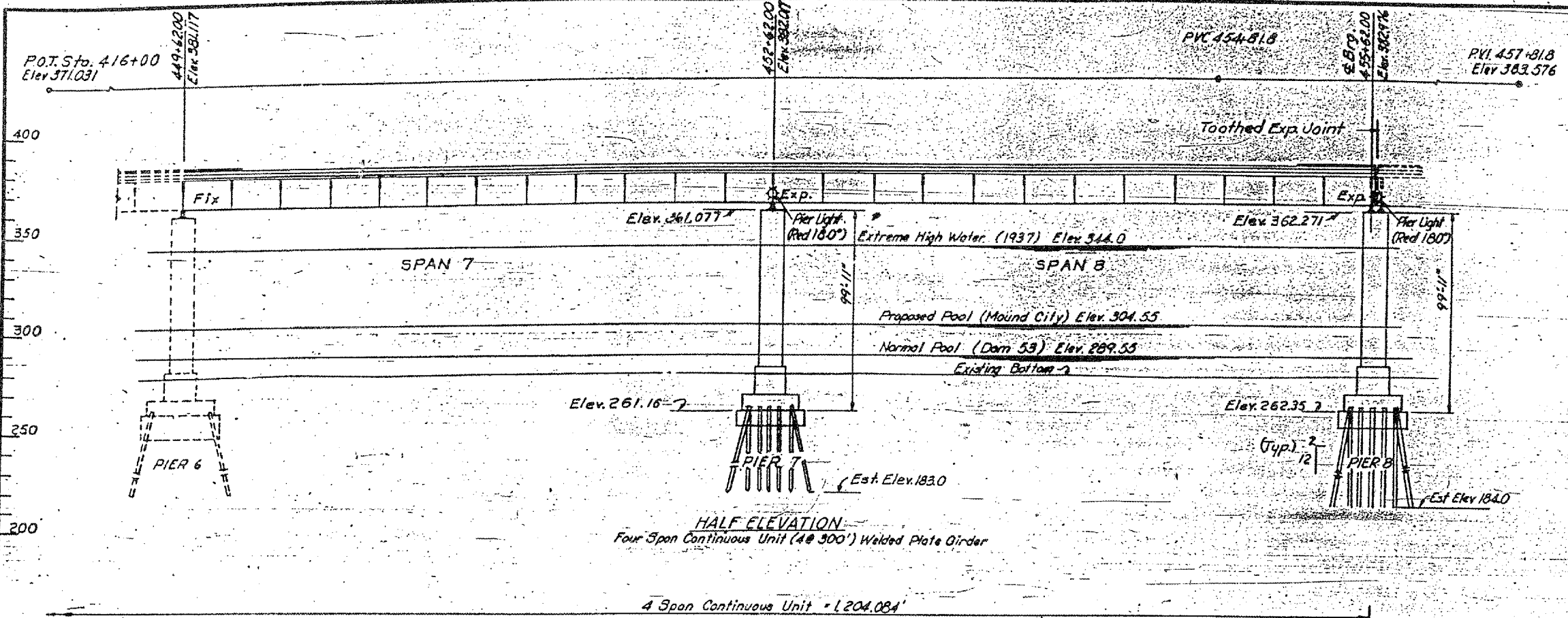

KENTUCKY DEPARTMENT OF HIGHWAYS
 ILLINOIS DEPARTMENT OF PUBLIC WORKS
 AND BUILDINGS

PROJECTS: I 24-116130, I 24-91130, I 24-11611
 BRIDGE OVER OHIO RIVER ON 124
 BETWEEN McCRACKEN COUNTY, KENTUCKY
 AND MASSAC COUNTY, ILLINOIS

HAZLET & BRAD Consulting Engineers INC. No. 007	BRIDGE NUMBER 17471	DRAWING NO. 17471	SHEET 9 OF 99
---	---------------------------	----------------------	------------------

UNIT III (111-KY)
 LAYOUT

CONTRACT: 98990
 ROUTE: INTERSTATE 24
 SECTION: (64-3B)1-6
 COUNTY: MASSAC IL; McCracken, KY
 SHEET 11 OF 99
 FOR INFORMATION ONLY

see sheet No. 6
 For Typical Section see Sheet No. 8

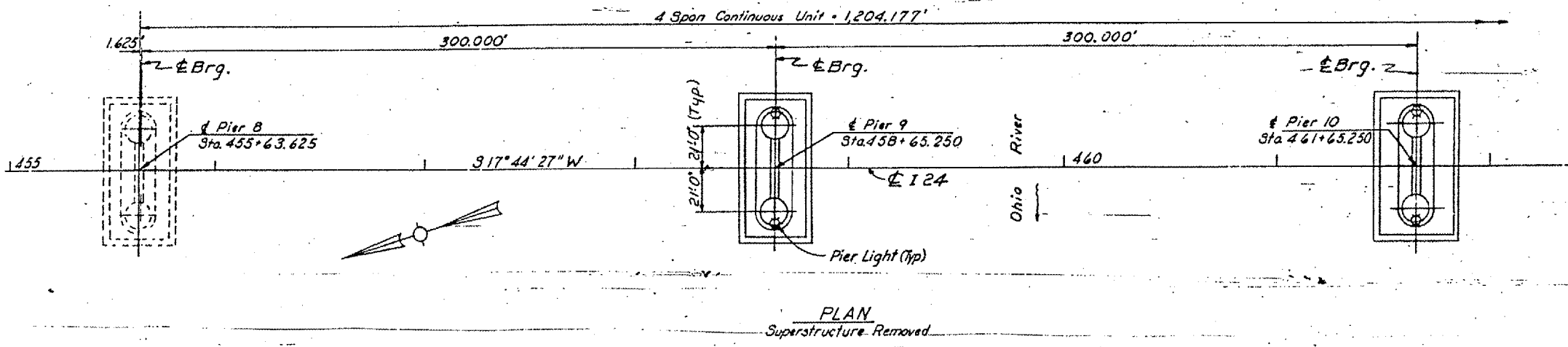
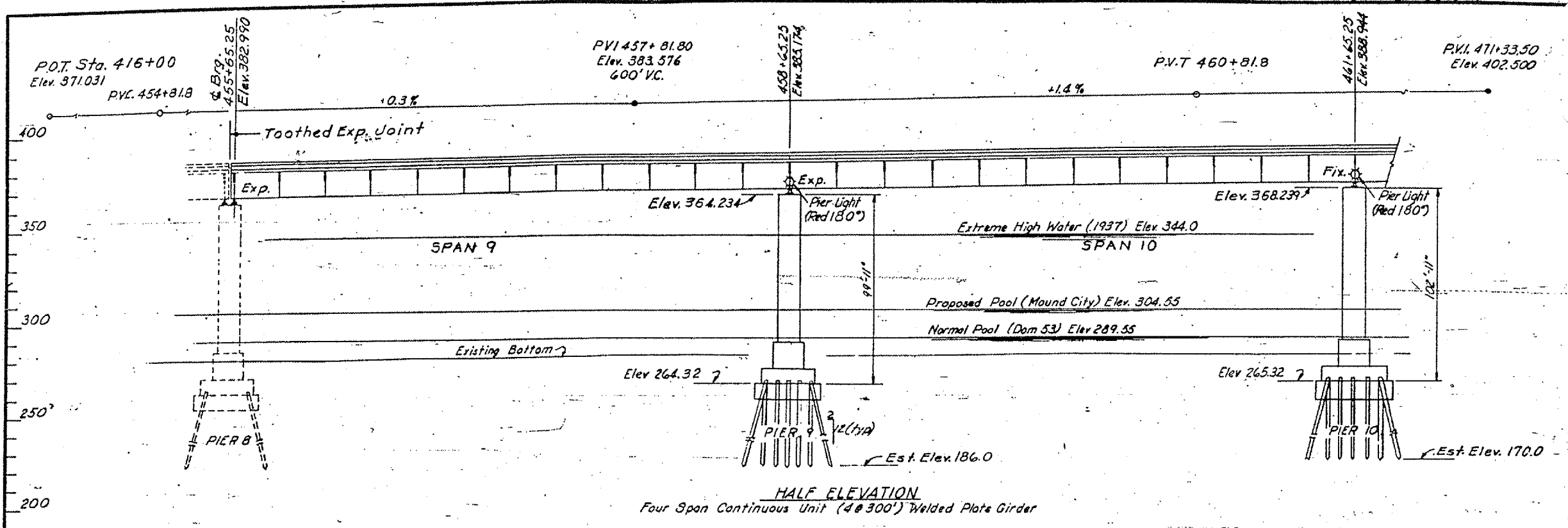

UNIT IX (IL-Ky)
 LAYOUT

SHEET 10 OF 21

**KENTUCKY DEPARTMENT OF HIGHWAYS
 ILLINOIS DEPARTMENT OF PUBLIC WORKS
 AND BUILDINGS**

PROJECTS I 24-1(6)38, I 24-8(1)0, I 24-1(6)1
 BRIDGE OVER OHIO RIVER ON 124
 BETWEEN MACCRACKEN COUNTY, KENTUCKY
 AND MASSAC COUNTY, ILLINOIS

HAZLET & BRAD Consulting Engineers File No. 998	BRIDGE NUMBER	DRAWING NO. 17471
---	------------------	----------------------

CONTRACT: 98990
 ROUTE: INTERSTATE 24
 SECTION: (64-3B) I-6
 COUNTY: MASSAC, IL; McCRACKEN, KY
 SHEET 12 OF 99
 FOR INFORMATION ONLY

see Sheet N 8 G
 For Typical Section, see Sheet N 8 B

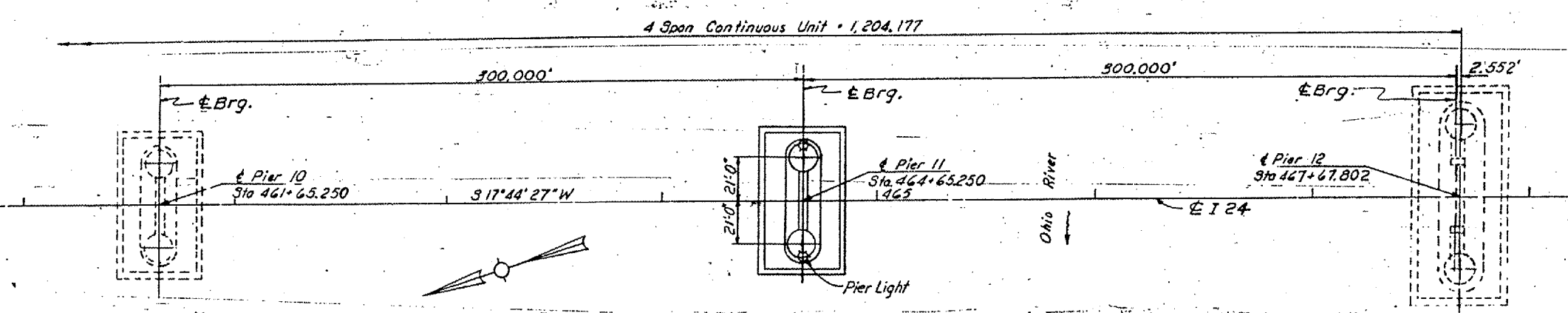
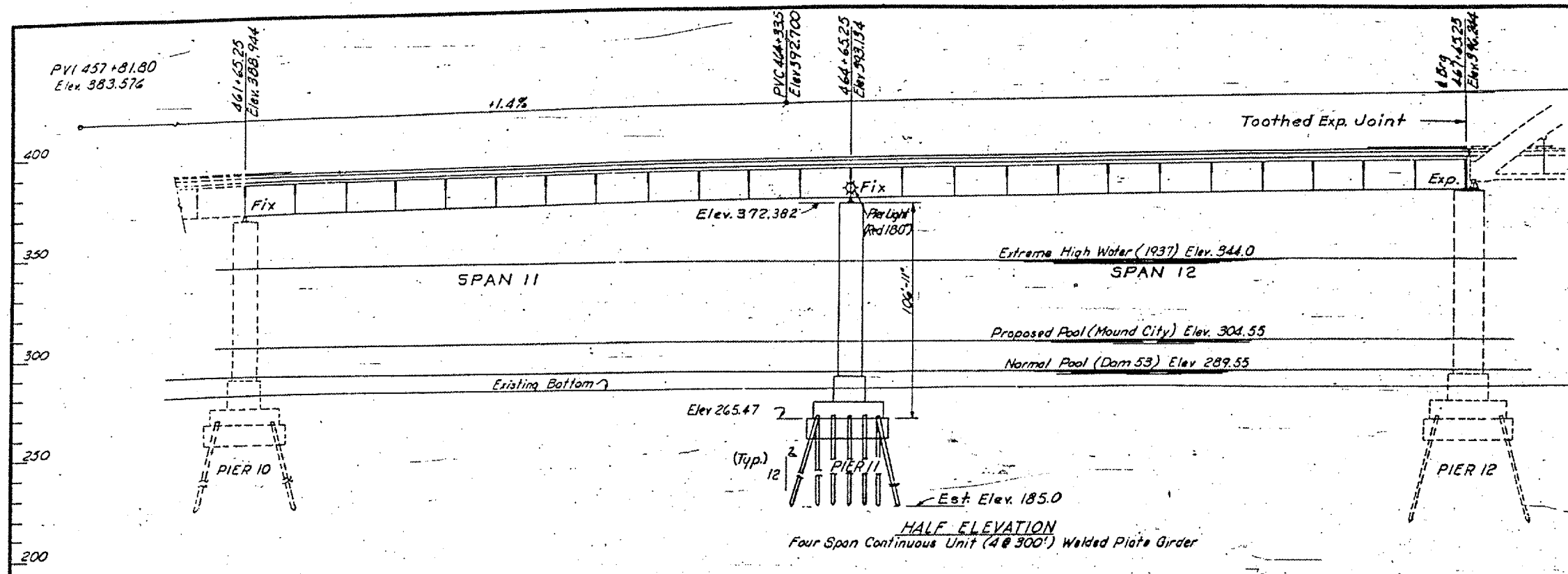

UNIT IX (III-Ky)
 LAYOUT

SHEET 11 OF 121

**KENTUCKY DEPARTMENT OF HIGHWAYS
 ILLINOIS DEPARTMENT OF PUBLIC WORKS
 AND BUILDINGS**

PROJECTS I 24-1(6)38, I 24-9(1)0, I 24-1(2)1
 BRIDGE OVER OHIO RIVER ON I 24
 BETWEEN McCRACKEN COUNTY, KENTUCKY
 AND MASSAC COUNTY, ILLINOIS

HAZLET & BIRDA Consulting Engineers File No. 286	BRIDGE NUMBER	DRAWING NO. 17471	INDEX
--	------------------	-----------------------------	-------

CONTRACT: 98990
 ROUTE: INTERSTATE 24
 SECTION: (64-3B) I-6
 COUNTY: MASSAC, IL; McCracken, KY
 SHEET 13 OF 99
 FOR INFORMATION ONLY

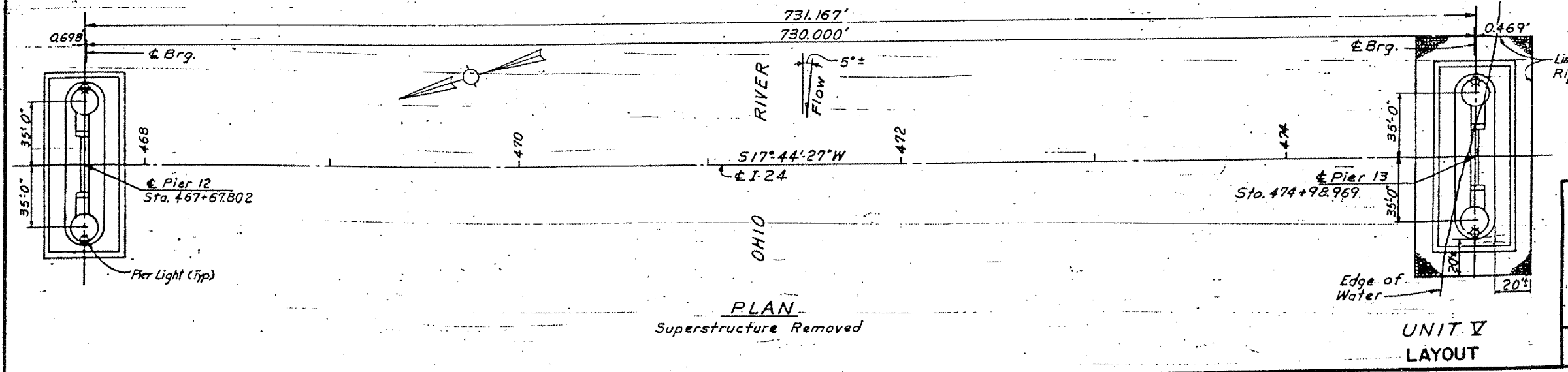
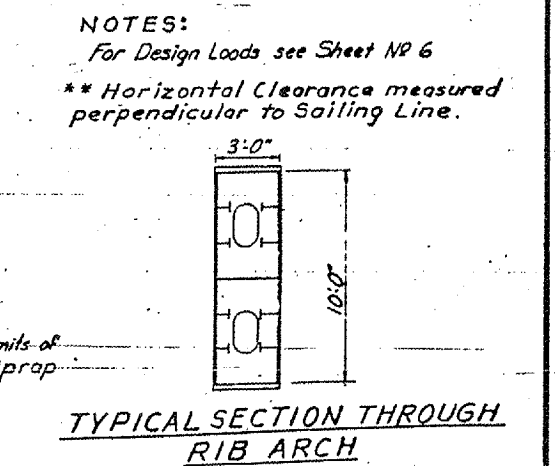
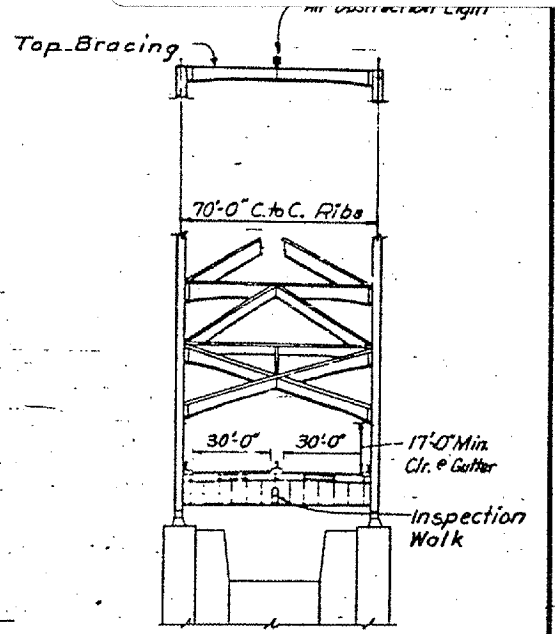
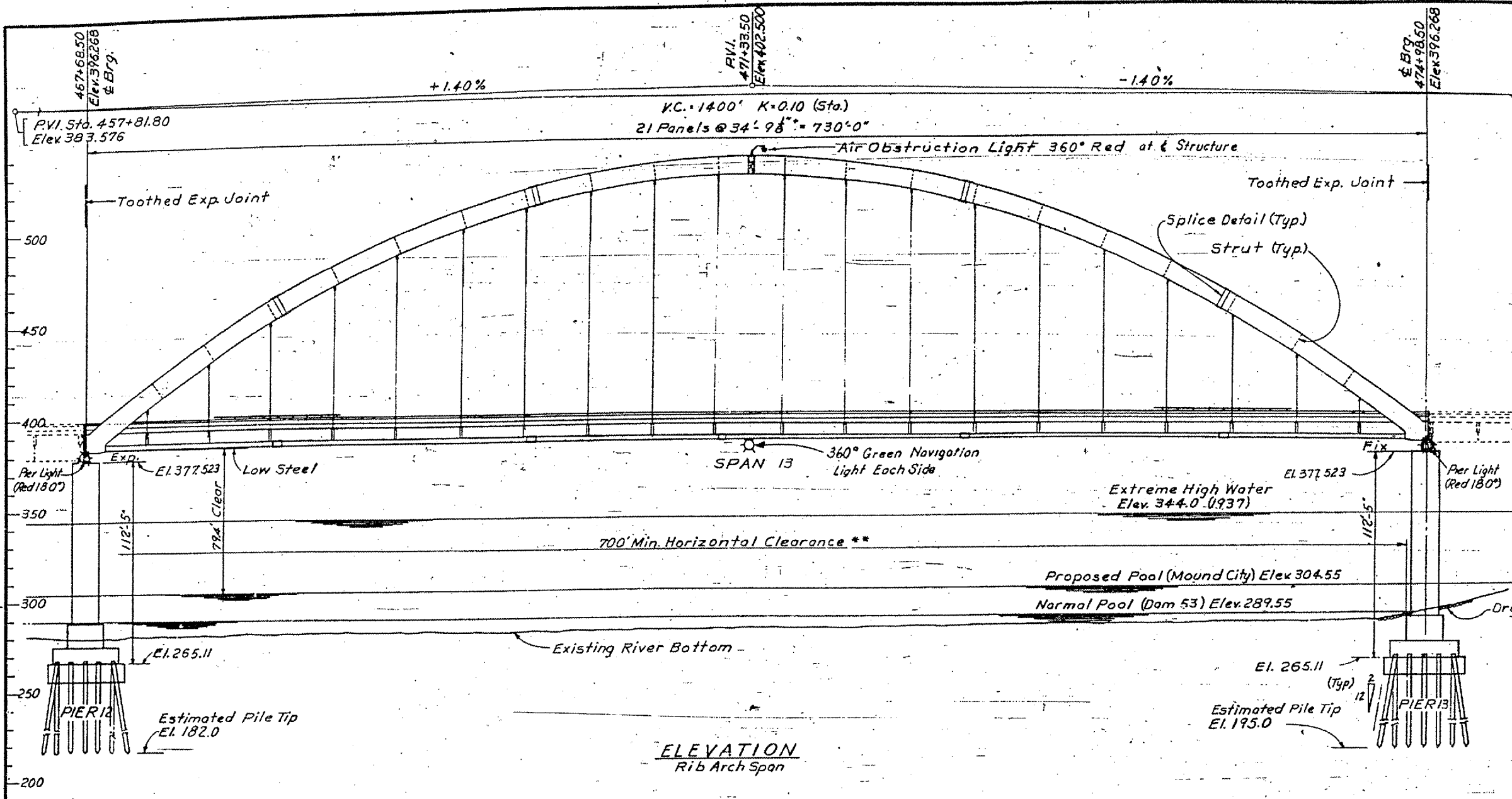

SHEET 12 OF 21

**KENTUCKY DEPARTMENT OF HIGHWAYS
 ILLINOIS DEPARTMENT OF PUBLIC WORKS
 AND BUILDINGS**

PROJECTS I 24-1(6)38, I 24-9(1)0, I 24-1(6)1
 BRIDGE OVER OHIO RIVER ON I 24
 BETWEEN McCRACKEN COUNTY, KENTUCKY
 AND MASSAC COUNTY, ILLINOIS

HAZLET & REDAL Consulting Engineers P.O. No. 288	BRIDGE NUMBER	DRAWING NO. 17471	SHEET 13
--	------------------	----------------------	-------------

CONTRACT: 98990
 ROUTE: INTERSTATE 24
 SECTION: (64-3B) I-6
 COUNTY: MASSAC, IL; McCRACKEN, KY
 SHEET 14 OF 99
 FOR INFORMATION ONLY
 and Typical Section See Sheet 6

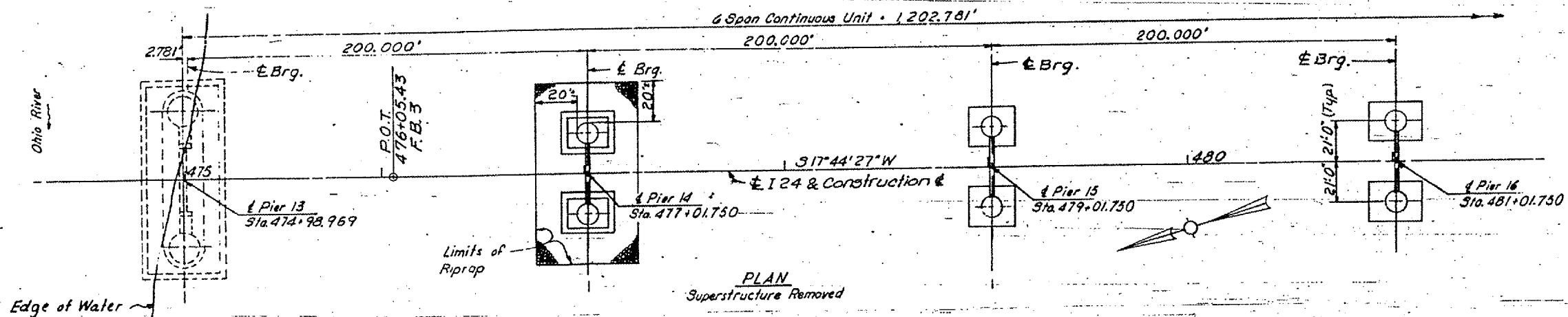
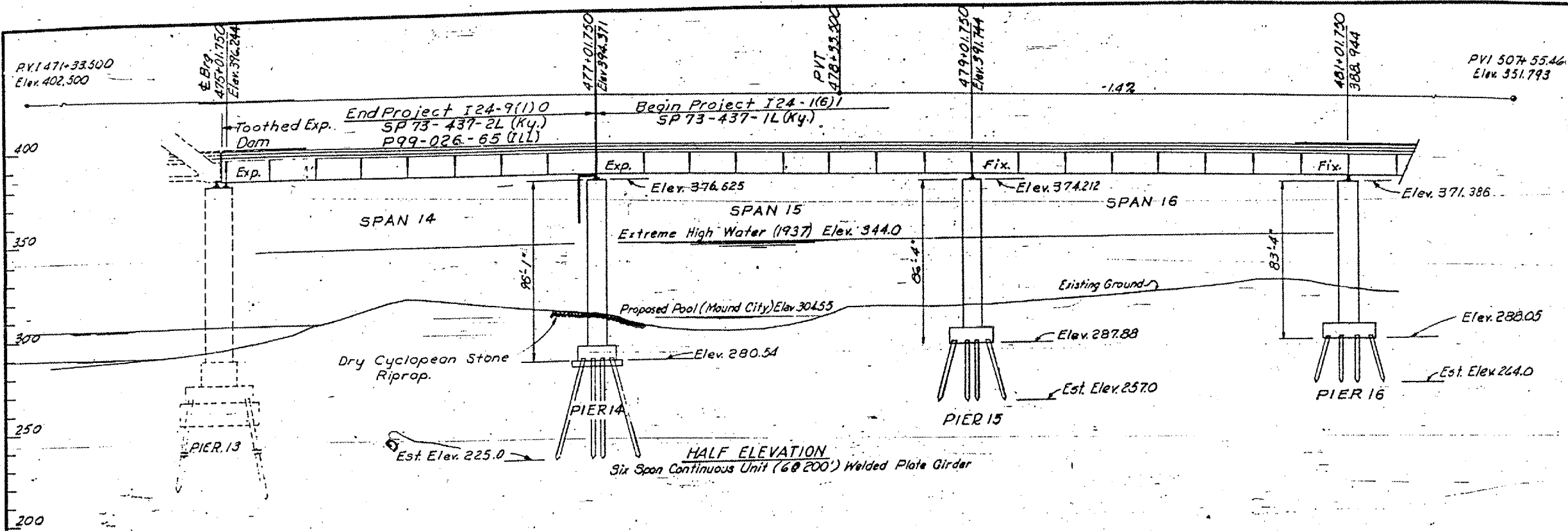

SHEET 13 OF 21

KENTUCKY DEPARTMENT OF HIGHWAYS
ILLINOIS DEPARTMENT OF PUBLIC WORKS
NEW BUILDINGS

PROJECT: I 24-1(6) 28, I 24-9(1) 0, I 24-1(6) 11
 BRIDGE OVER OHIO RIVER ON I 24
 BETWEEN McCRACKEN COUNTY, KENTUCKY
 AND MASSAC COUNTY, ILLINOIS

HAZLET & BIRAL Consulting Engineers File No. 99	BRIDGE NUMBER	DRAWING NO. 17471	PAGE 1
---	------------------	----------------------	-----------

UNIT II (Kentucky)
 LAYOUT

CONTRACT: 98990
 ROUTE: INTERSTATE 24
 SECTION: (64-3B)1-6
 COUNTY: MASSAC, IL; McCRACKEN, KY
 SHEET 15 OF 99
 FOR INFORMATION ONLY

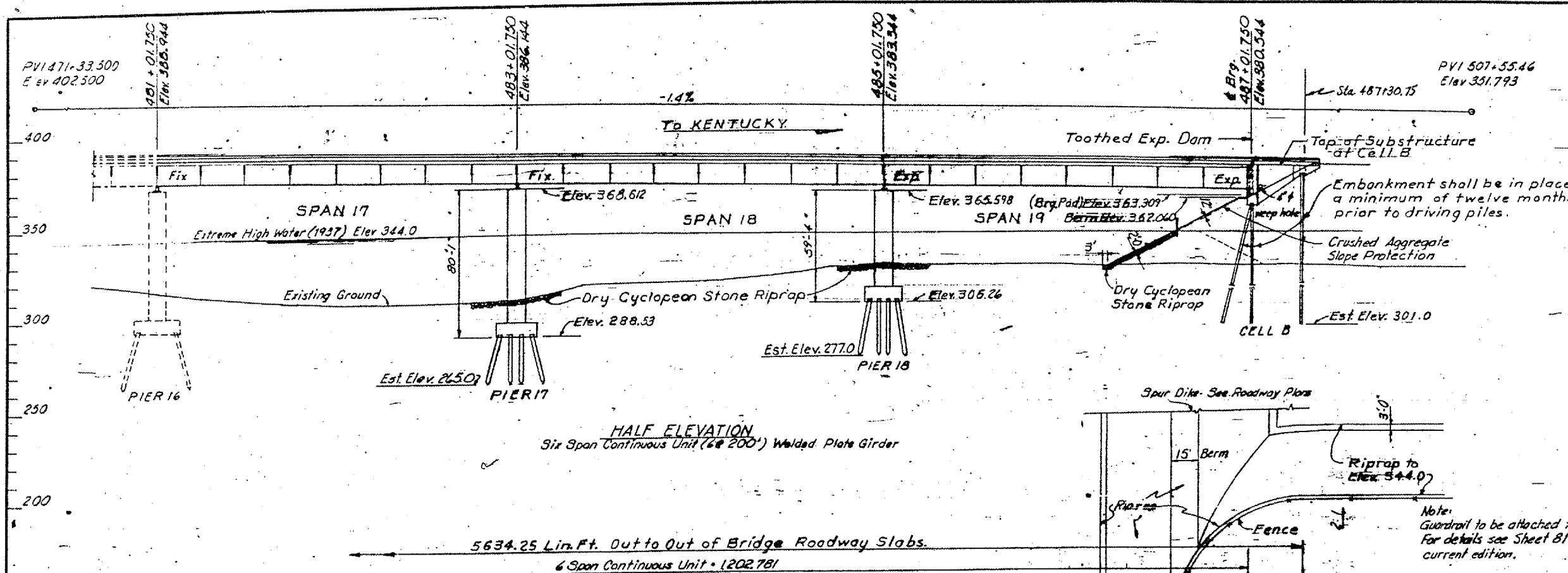

and Typical Section, see Sheet 6
 * Indicates Construction By Others

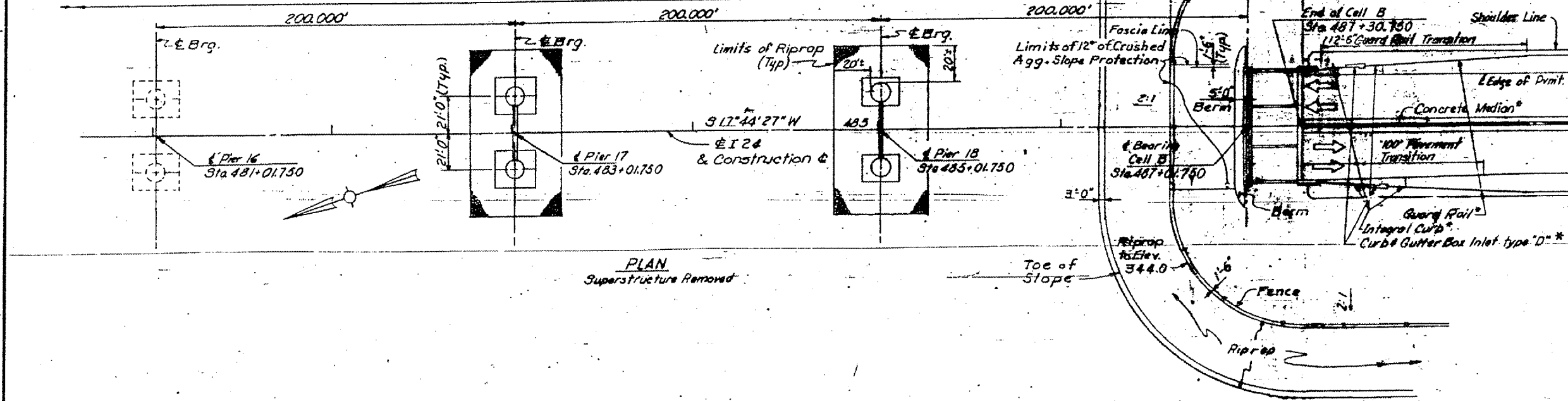

Note:
 Guardrail to be attached to Each Wing of Cell B.
 For details see Sheet 81 and Std. Drawing 17.40,
 current edition.

DESIGNED BY: RBS
 CHECKED BY: [Signature]
 DATE: [Date]
 DRAWING NO.: 17471
 SHEET 15 OF 99

SHEET 15 OF 99

**KENTUCKY DEPARTMENT OF HIGHWAYS
 ILLINOIS DEPARTMENT OF PUBLIC WORKS
 AND BUILDINGS**

PROJECTS I 24-1(6)38, I 24-9(1)0, I 24-1(6)1
 BRIDGE OVER OHIO RIVER ON I 24
 BETWEEN McCRACKEN COUNTY, KENTUCKY
 AND MASSAC COUNTY, ILLINOIS

HAZLET & BRAD Consulting Engineers No. 10, 248	BRIDGE NUMBER	DRAWING NO. 17471	INDEX
--	------------------	----------------------	-------

**UNIT III (Kentucky)
 LAYOUT**

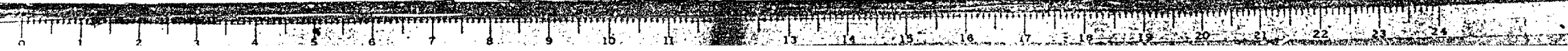

CONTRACT: 98990
 ROUTE: INTERSTATE 24
 SECTION: (64-3B) I-6
 COUNTY: MASSAC, IL; McCRACKEN, KY
 SHEET **16** OF **99**
 FOR INFORMATION ONLY

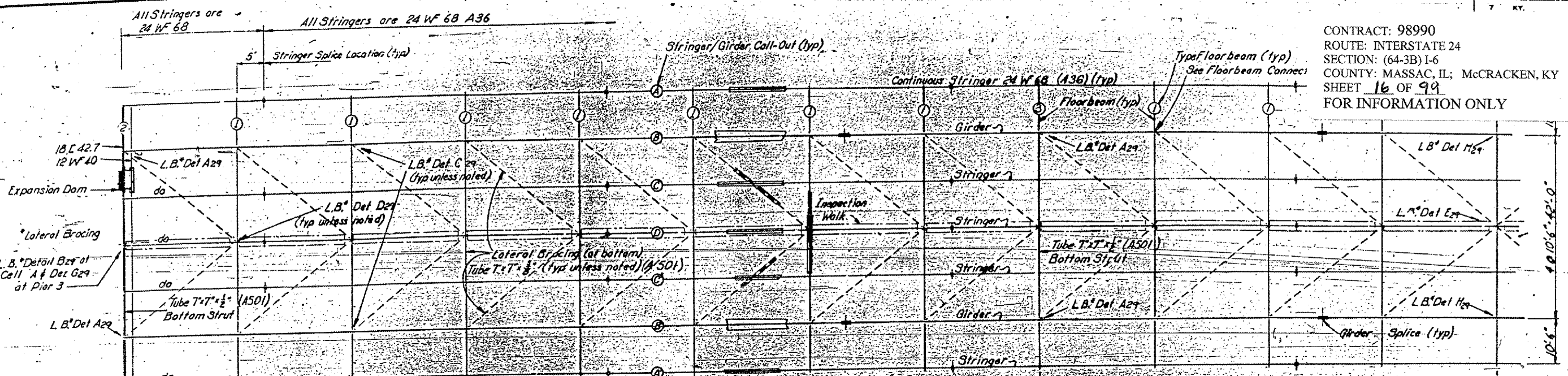

Expansion Dam
 L.B. Detail B29 at Pier 3
 L.B. Detail A29
 L.B. Detail C29 (Typ unless noted)
 L.B. Detail D29 (Typ unless noted)
 L.B. Detail E29
 L.B. Detail F29
 L.B. Detail G29
 L.B. Detail H29
 L.B. Detail I29
 L.B. Detail J29
 L.B. Detail K29
 L.B. Detail L29
 L.B. Detail M29
 L.B. Detail N29
 L.B. Detail O29
 L.B. Detail P29
 L.B. Detail Q29
 L.B. Detail R29
 L.B. Detail S29
 L.B. Detail T29
 L.B. Detail U29
 L.B. Detail V29
 L.B. Detail W29
 L.B. Detail X29
 L.B. Detail Y29
 L.B. Detail Z29

FRAMING PLAN (HALF UNIT)
 SPANS 1 & 3
 SPAN 2 (Half)

All $\frac{1}{2}$ " Stiffeners except of Piers See F.B. Details

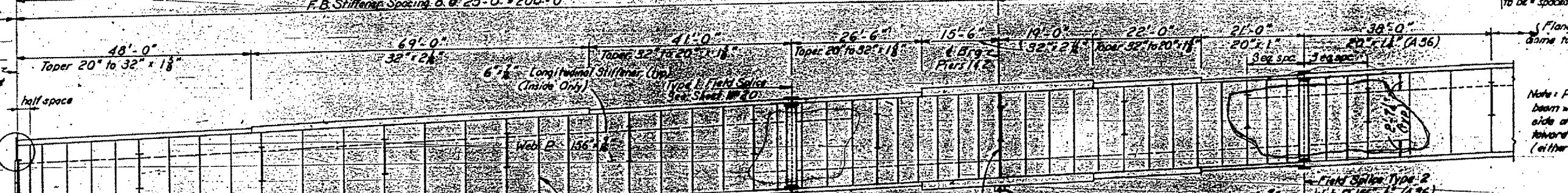

GIRDER ELEVATION

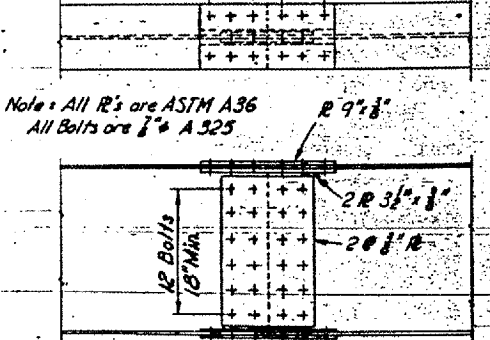

STRINGER SPlice
 USE IN UNITS I, II, III & IV

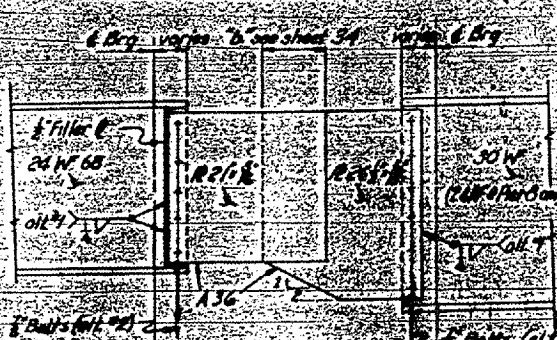

FASCIA STRINGER DETAIL
 USE AT PIERS 3, 4, 5, 12 & 13 (Outside Only)

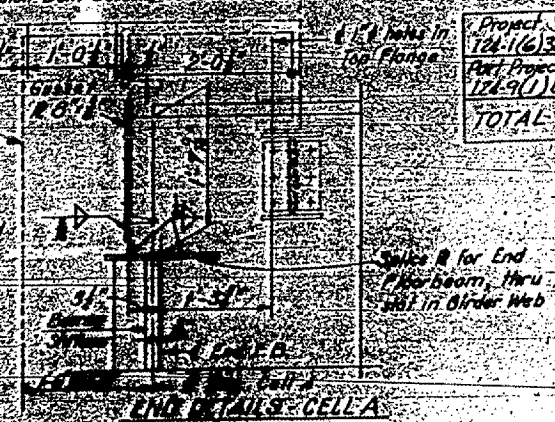

UNIT I Framing & Plate Girder Structural Steel

UNIT I STRUCTURAL STEEL QUANTITIES (LBS)					
Drains	A 36	A 441	Shoes	Exp. Dam	
Project 174-1(6) 35	200,064	178,589	13,322	34,758	
Part Project 174-9(1) D	445,294	298,921	13,322	37,135	
TOTAL	645,358	477,510	26,644	71,893	

* Includes 690 Lbs. for Armored Edge in Cell A.

SHEET 15 OF 21

**KENTUCKY DEPARTMENT OF HIGHWAYS
 ILLINOIS DEPARTMENT OF PUBLIC WORKS
 AND BUILDINGS**

PROJECTS I 24-1(6) 38, I 24-9(1) 10, I 24-1(6) 11

BRIDGE OVER OHIO RIVER ON I 24
 BETWEEN McCRACKEN COUNTY, KENTUCKY
 AND MASSAC COUNTY, ILLINOIS

MALLEN & BEAL
 Consulting Engineers
 File No. 256

BRIDGE NUMBER

DRAWING NO.
17471

INDEX

Prepared by: C.H.H.
 Checked by: P.H.S.
 Date: 9-62
 Scale: AS SHOWN
 SHEET 15 OF 21

CONTRACT: 98990
ROUTE: INTERSTATE 24
SECTION: (64-3B) I-6
COUNTY: MASSAC, IL; McCRACKEN, KY
SHEET 17 OF 99
FOR INFORMATION ONLY

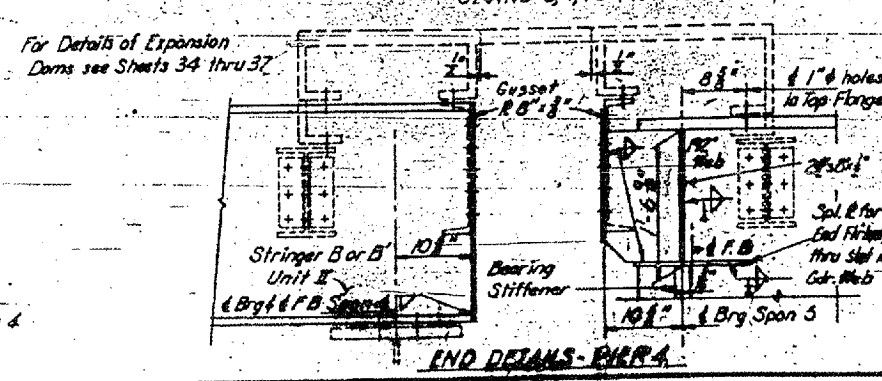
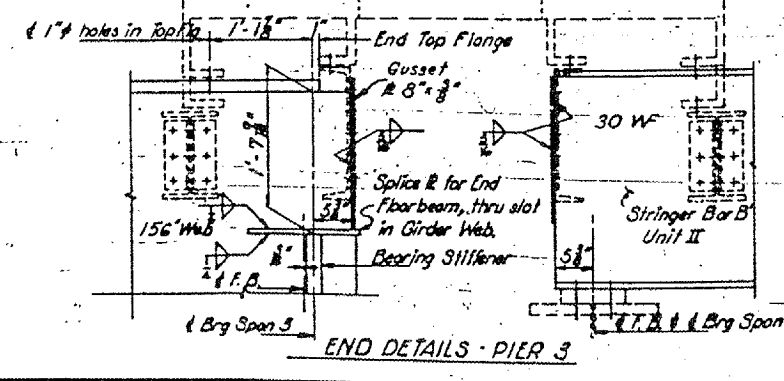
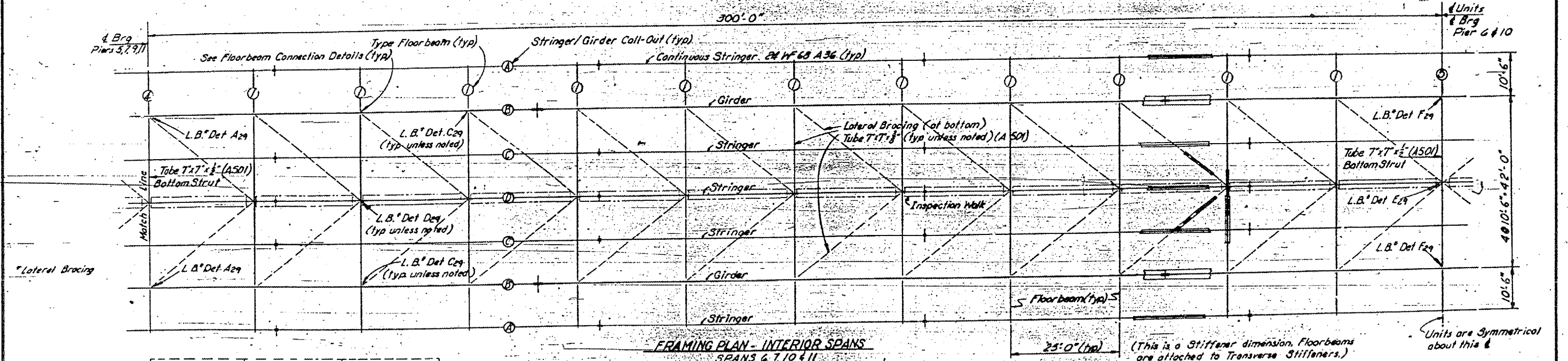
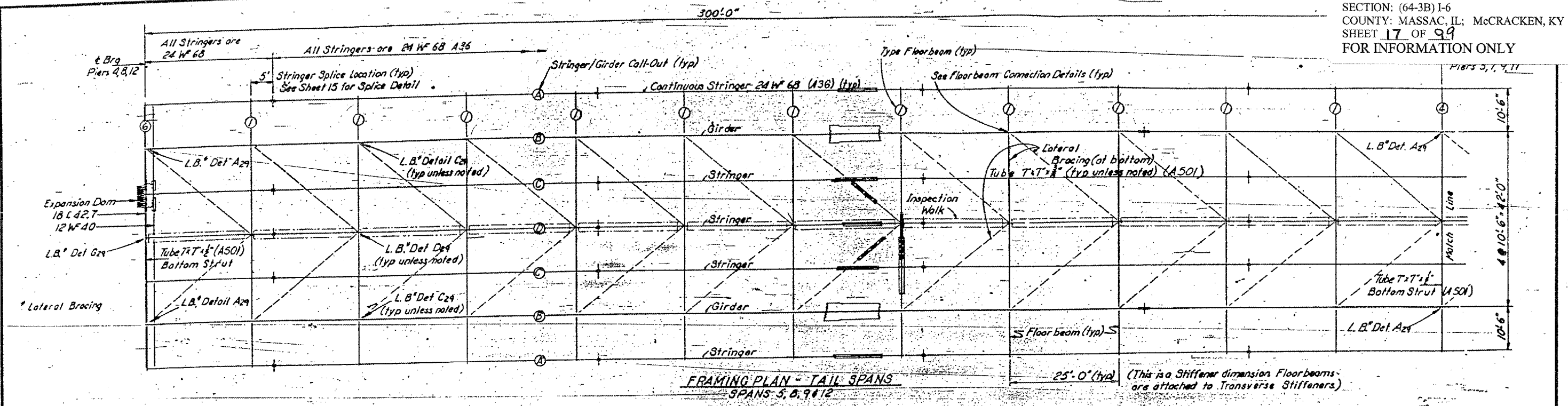

Part Project	STRUCTURAL STEEL QUANTITIES (LBS)				
	Drains	A36	A441 A501 Min.	Shoes	Exp. Dam
Unit II	6,754	1,253,587	1,410,880 1,238,782	64,798	70,130
Unit IV	6,619	1,253,663	1,410,748 1,238,752	64,822	82,309

UNITS III & IV FRAMING STRUCTURAL STEEL

HAZLET & BISHOP
Consulting Engineers
File No. 999

KENTUCKY DEPARTMENT OF HIGHWAYS
ILLINOIS DEPARTMENT OF PUBLIC WORKS
AND BUILDINGS

PROJECTS I 24-1(6)38, I 24-8(110), I 24-1(6)11
BRIDGE OVER OHIO RIVER ON I 24
BETWEEN McCRACKEN COUNTY, KENTUCKY
AND MASSAC COUNTY, ILLINOIS

DRAWING NO. 17471

INDEX

REVISIONS: DATE, BY, DESCRIPTION

CONTRACT: 98990
 ROUTE: INTERSTATE 24
 SECTION: (64-3B) 1-6
 COUNTY: MASSAC, IL; McCRACKEN, KY
 SHEET 18 OF 99
 FOR INFORMATION ONLY

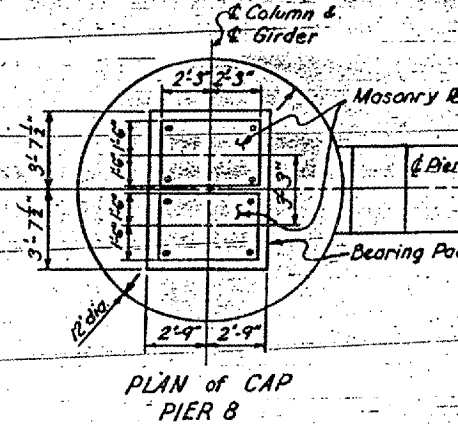
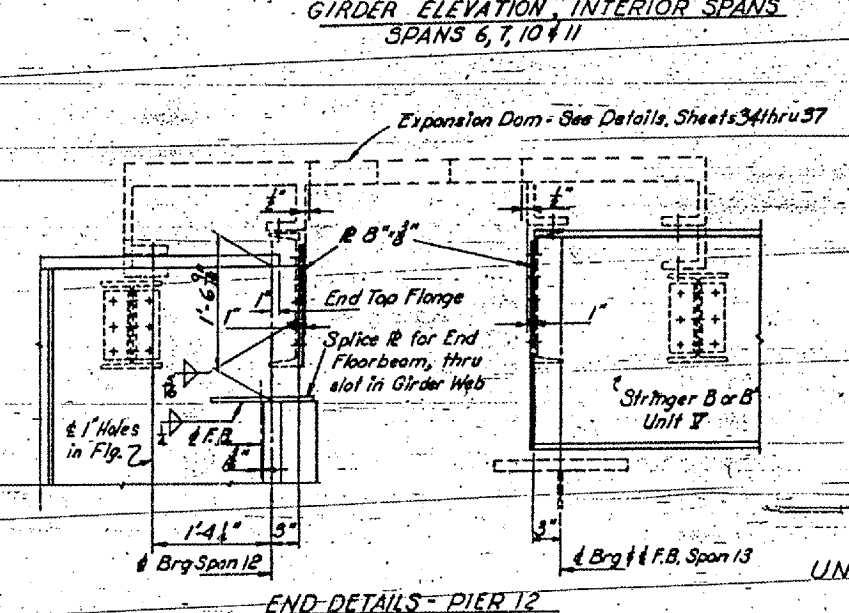
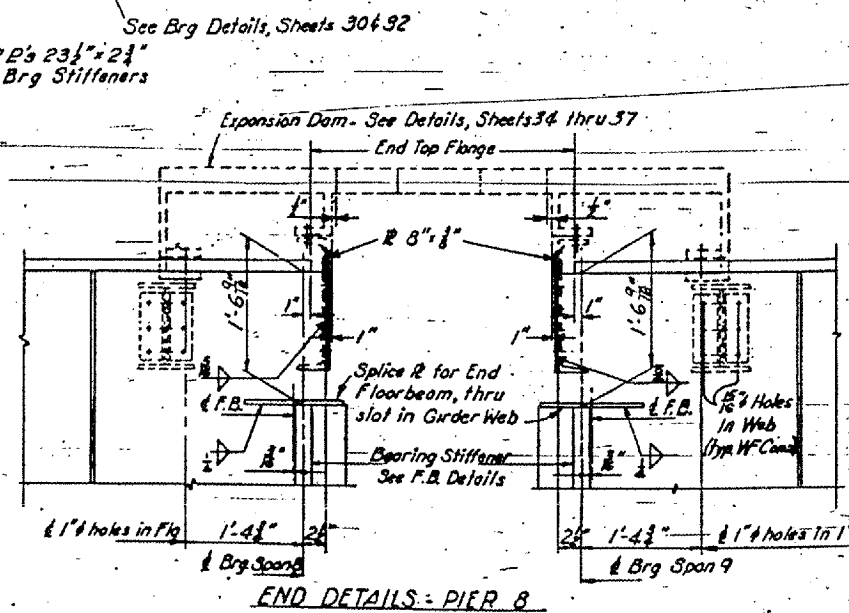
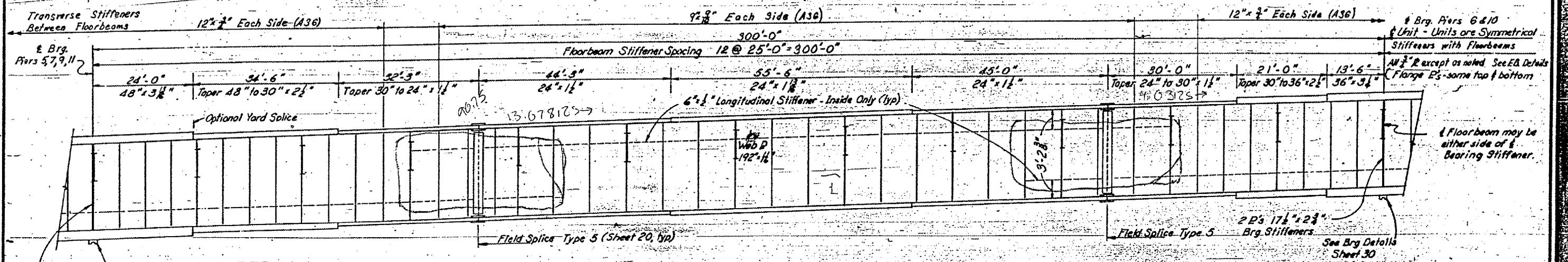
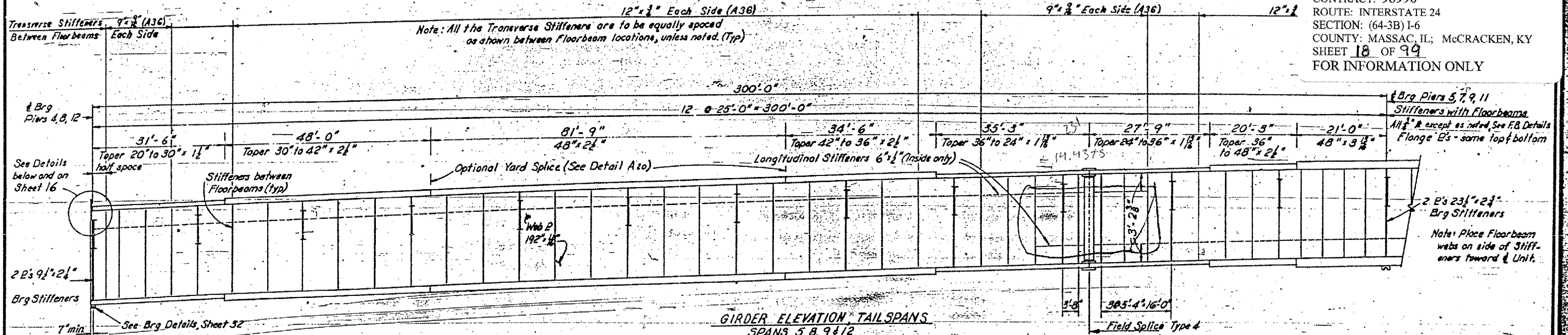

Note: All Transverse and Bearing Stiffeners, Floorbeam Webs, and of Units, and splices are to be vertical. Longitudinal and intermediate Transverse Stiffeners may be A36 Steel. All longitudinal dimensions are Horizontal and girder lengths should be adjusted for grade.

SHEET 17 OF 121

**KENTUCKY DEPARTMENT OF HIGHWAYS
 ILLINOIS DEPARTMENT OF PUBLIC WORKS
 AND BUILDINGS**

PROJECTS I 24-1(6)30; I 24-9(110); I 24-1(6)11
 BRIDGE OVER OSBO RIVER ON I 24
 BETWEEN McCRACKEN COUNTY, KENTUCKY
 AND MASSAC COUNTY, ILLINOIS

HAZLET & BRIDAL Consulting Engineers P.O. No. 505	DESIGN NUMBER 17471	DRAWING NO. 17471
---	------------------------	----------------------

**UNITS III & IV PLATE GIRDERS
 STRUCTURAL STEEL**

CONTRACT: 98990
 ROUTE: INTERSTATE 24
 SECTION: (64-3B) I-6
 COUNTY: MASSAC, IL; McCRACKEN, KY
 SHEET 19 OF 99
 FOR INFORMATION ONLY

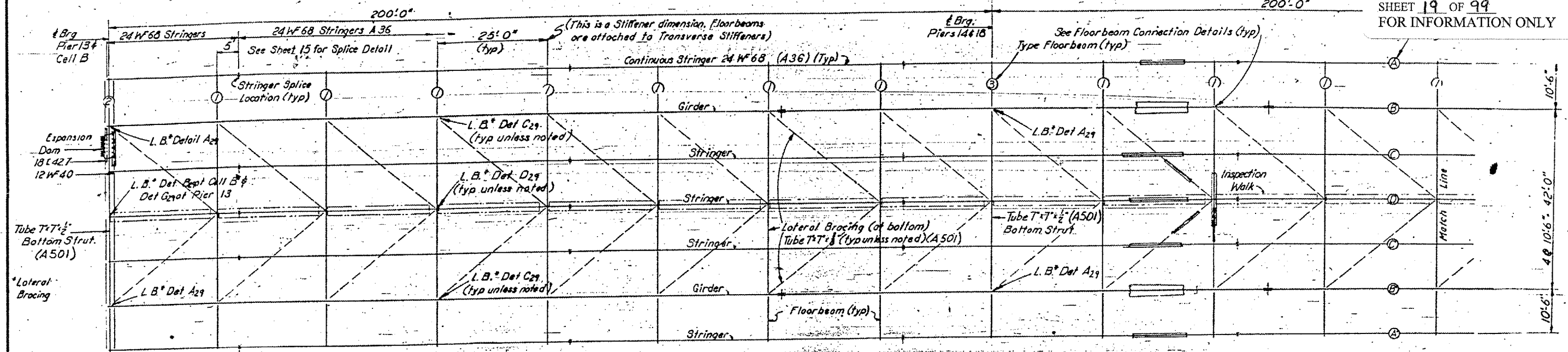

TAIL SPAN SPANS 14 & 19 FRAMING PLAN FIRST INTERIOR SPANS (HALF) SPANS 15 & 18

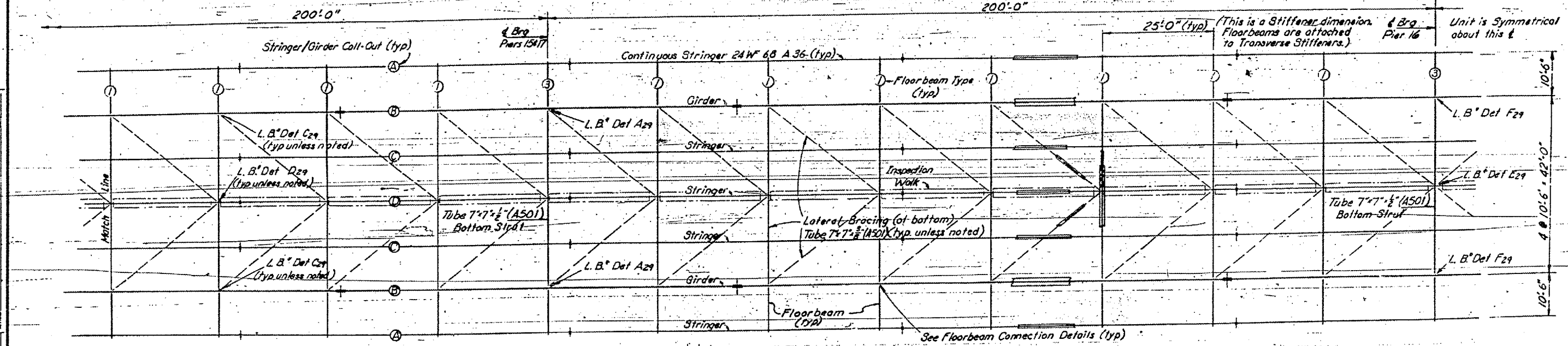

FIRST INTERIOR SPANS (HALF) SPANS 15 & 18 FRAMING PLAN INTERIOR (CENTER) SPANS SPANS 16 & 17

	UNIT VI STRUCTURAL STEEL QUANTITIES (LBS)				
	Drains	A36	A441 Mod	Shoes	Exp Dam
Part Project I24-9(1)0	1069	174,442	178,654	6,508	30,297
Project I24-1(6)1	5665	*949,945	863,641	57,290	41,676
TOTAL	6,734	1,124,387	1,042,295	63,778	719,73

* Includes 690 lbs for Armored Edge in Cell B.

UNIT VI FRAMING PLAN
 STRUCTURAL STEEL

SHEET 18

KENTUCKY DEPARTMENT OF HIGHWAYS & ILLINOIS DEPARTMENT OF PUBLIC WORKS AND BUILDINGS

PROJECTS I 24-1(6)30, I 24-9(1)0, I 24-1(6)1
 BRIDGE OVER OHIO RIVER ON I 24
 BETWEEN McCRACKEN COUNTY, KENTUCKY AND MASSAC COUNTY, ILLINOIS

HAZLET & BIRDA Consulting Engineers P.O. No. 200	BRIDGE NUMBER	DRAWING NO. 17471
--	---------------	----------------------

REVISIONS: 1. DATE: 11/10/00 BY: JCH/ML/ML
 2. DATE: 11/10/00 BY: JCH/ML/ML
 3. DATE: 11/10/00 BY: JCH/ML/ML
 4. DATE: 11/10/00 BY: JCH/ML/ML
 5. DATE: 11/10/00 BY: JCH/ML/ML
 6. DATE: 11/10/00 BY: JCH/ML/ML
 7. DATE: 11/10/00 BY: JCH/ML/ML
 8. DATE: 11/10/00 BY: JCH/ML/ML
 9. DATE: 11/10/00 BY: JCH/ML/ML
 10. DATE: 11/10/00 BY: JCH/ML/ML
 11. DATE: 11/10/00 BY: JCH/ML/ML
 12. DATE: 11/10/00 BY: JCH/ML/ML
 13. DATE: 11/10/00 BY: JCH/ML/ML
 14. DATE: 11/10/00 BY: JCH/ML/ML
 15. DATE: 11/10/00 BY: JCH/ML/ML
 16. DATE: 11/10/00 BY: JCH/ML/ML
 17. DATE: 11/10/00 BY: JCH/ML/ML
 18. DATE: 11/10/00 BY: JCH/ML/ML
 19. DATE: 11/10/00 BY: JCH/ML/ML
 20. DATE: 11/10/00 BY: JCH/ML/ML
 21. DATE: 11/10/00 BY: JCH/ML/ML
 22. DATE: 11/10/00 BY: JCH/ML/ML
 23. DATE: 11/10/00 BY: JCH/ML/ML
 24. DATE: 11/10/00 BY: JCH/ML/ML
 25. DATE: 11/10/00 BY: JCH/ML/ML
 26. DATE: 11/10/00 BY: JCH/ML/ML
 27. DATE: 11/10/00 BY: JCH/ML/ML
 28. DATE: 11/10/00 BY: JCH/ML/ML
 29. DATE: 11/10/00 BY: JCH/ML/ML
 30. DATE: 11/10/00 BY: JCH/ML/ML
 31. DATE: 11/10/00 BY: JCH/ML/ML
 32. DATE: 11/10/00 BY: JCH/ML/ML
 33. DATE: 11/10/00 BY: JCH/ML/ML
 34. DATE: 11/10/00 BY: JCH/ML/ML
 35. DATE: 11/10/00 BY: JCH/ML/ML
 36. DATE: 11/10/00 BY: JCH/ML/ML
 37. DATE: 11/10/00 BY: JCH/ML/ML
 38. DATE: 11/10/00 BY: JCH/ML/ML
 39. DATE: 11/10/00 BY: JCH/ML/ML
 40. DATE: 11/10/00 BY: JCH/ML/ML
 41. DATE: 11/10/00 BY: JCH/ML/ML
 42. DATE: 11/10/00 BY: JCH/ML/ML
 43. DATE: 11/10/00 BY: JCH/ML/ML
 44. DATE: 11/10/00 BY: JCH/ML/ML
 45. DATE: 11/10/00 BY: JCH/ML/ML
 46. DATE: 11/10/00 BY: JCH/ML/ML
 47. DATE: 11/10/00 BY: JCH/ML/ML
 48. DATE: 11/10/00 BY: JCH/ML/ML
 49. DATE: 11/10/00 BY: JCH/ML/ML
 50. DATE: 11/10/00 BY: JCH/ML/ML
 51. DATE: 11/10/00 BY: JCH/ML/ML
 52. DATE: 11/10/00 BY: JCH/ML/ML
 53. DATE: 11/10/00 BY: JCH/ML/ML
 54. DATE: 11/10/00 BY: JCH/ML/ML
 55. DATE: 11/10/00 BY: JCH/ML/ML
 56. DATE: 11/10/00 BY: JCH/ML/ML
 57. DATE: 11/10/00 BY: JCH/ML/ML
 58. DATE: 11/10/00 BY: JCH/ML/ML
 59. DATE: 11/10/00 BY: JCH/ML/ML
 60. DATE: 11/10/00 BY: JCH/ML/ML
 61. DATE: 11/10/00 BY: JCH/ML/ML
 62. DATE: 11/10/00 BY: JCH/ML/ML
 63. DATE: 11/10/00 BY: JCH/ML/ML
 64. DATE: 11/10/00 BY: JCH/ML/ML
 65. DATE: 11/10/00 BY: JCH/ML/ML
 66. DATE: 11/10/00 BY: JCH/ML/ML
 67. DATE: 11/10/00 BY: JCH/ML/ML
 68. DATE: 11/10/00 BY: JCH/ML/ML
 69. DATE: 11/10/00 BY: JCH/ML/ML
 70. DATE: 11/10/00 BY: JCH/ML/ML
 71. DATE: 11/10/00 BY: JCH/ML/ML
 72. DATE: 11/10/00 BY: JCH/ML/ML
 73. DATE: 11/10/00 BY: JCH/ML/ML
 74. DATE: 11/10/00 BY: JCH/ML/ML
 75. DATE: 11/10/00 BY: JCH/ML/ML
 76. DATE: 11/10/00 BY: JCH/ML/ML
 77. DATE: 11/10/00 BY: JCH/ML/ML
 78. DATE: 11/10/00 BY: JCH/ML/ML
 79. DATE: 11/10/00 BY: JCH/ML/ML
 80. DATE: 11/10/00 BY: JCH/ML/ML
 81. DATE: 11/10/00 BY: JCH/ML/ML
 82. DATE: 11/10/00 BY: JCH/ML/ML
 83. DATE: 11/10/00 BY: JCH/ML/ML
 84. DATE: 11/10/00 BY: JCH/ML/ML
 85. DATE: 11/10/00 BY: JCH/ML/ML
 86. DATE: 11/10/00 BY: JCH/ML/ML
 87. DATE: 11/10/00 BY: JCH/ML/ML
 88. DATE: 11/10/00 BY: JCH/ML/ML
 89. DATE: 11/10/00 BY: JCH/ML/ML
 90. DATE: 11/10/00 BY: JCH/ML/ML
 91. DATE: 11/10/00 BY: JCH/ML/ML
 92. DATE: 11/10/00 BY: JCH/ML/ML
 93. DATE: 11/10/00 BY: JCH/ML/ML
 94. DATE: 11/10/00 BY: JCH/ML/ML
 95. DATE: 11/10/00 BY: JCH/ML/ML
 96. DATE: 11/10/00 BY: JCH/ML/ML
 97. DATE: 11/10/00 BY: JCH/ML/ML
 98. DATE: 11/10/00 BY: JCH/ML/ML
 99. DATE: 11/10/00 BY: JCH/ML/ML
 100. DATE: 11/10/00 BY: JCH/ML/ML

CONTRACT: 98990
 ROUTE: INTERSTATE 24
 SECTION: (64-3B) I-6
 COUNTY: MASSAC, IL; McCRACKEN, KY
 SHEET 20 OF 99
 FOR INFORMATION ONLY

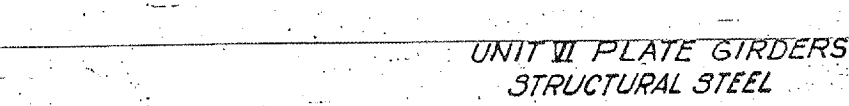
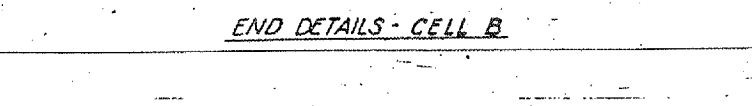
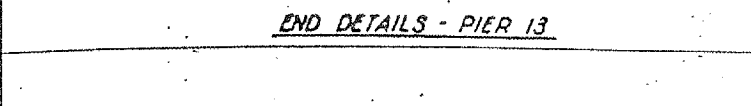
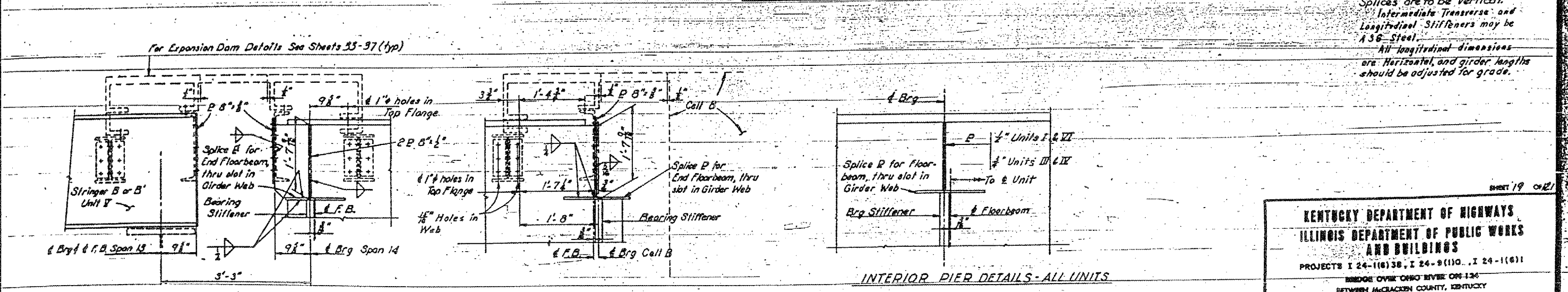
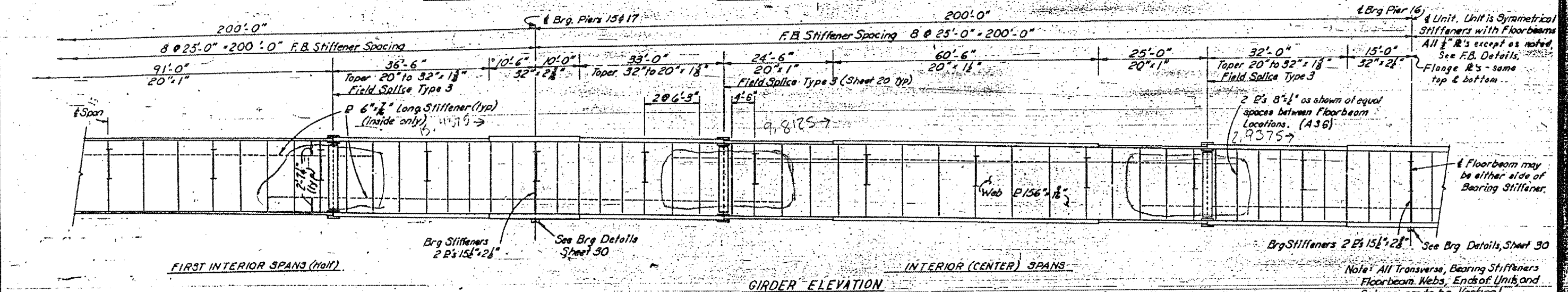
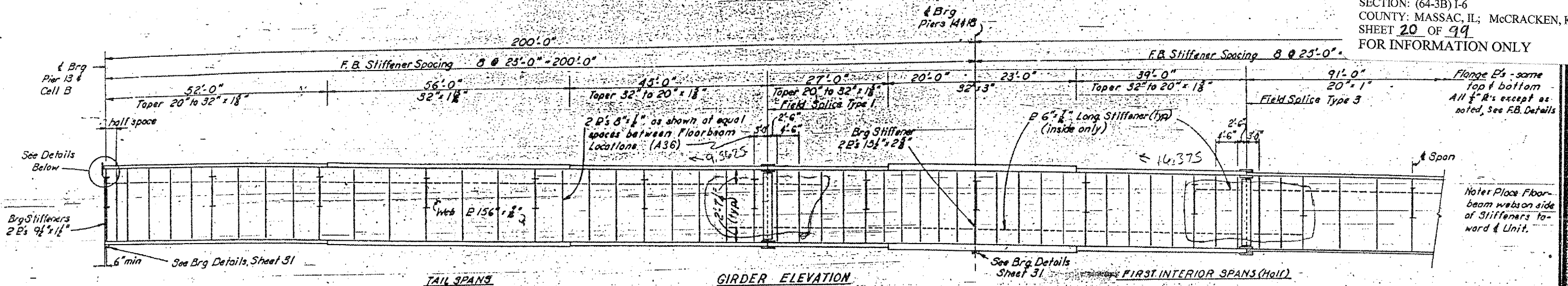

SHEET 19 OF 21

**KENTUCKY DEPARTMENT OF HIGHWAYS
 ILLINOIS DEPARTMENT OF PUBLIC WORKS
 AND BUILDINGS**

PROJECTS I 24-1(6)38, I 24-9(1)10, I 24-1(6)11
 BRIDGE OVER OHIO RIVER ON-134
 BETWEEN McCRACKEN COUNTY, KENTUCKY
 AND MASSAC COUNTY, ILLINOIS

HAZLET & BRIDAL Consulting Engineers P.O. No. 208	BRIDGE NUMBER 17471	DRAWING NO. DATE
---	---------------------------	---------------------

CONTRACT: 98990
 ROUTE: INTERSTATE 24
 SECTION: (64-3B) I-6
 COUNTY: MASSAC, IL; McCRACKEN, KY
 SHEET 21 OF 99
 FOR INFORMATION ONLY

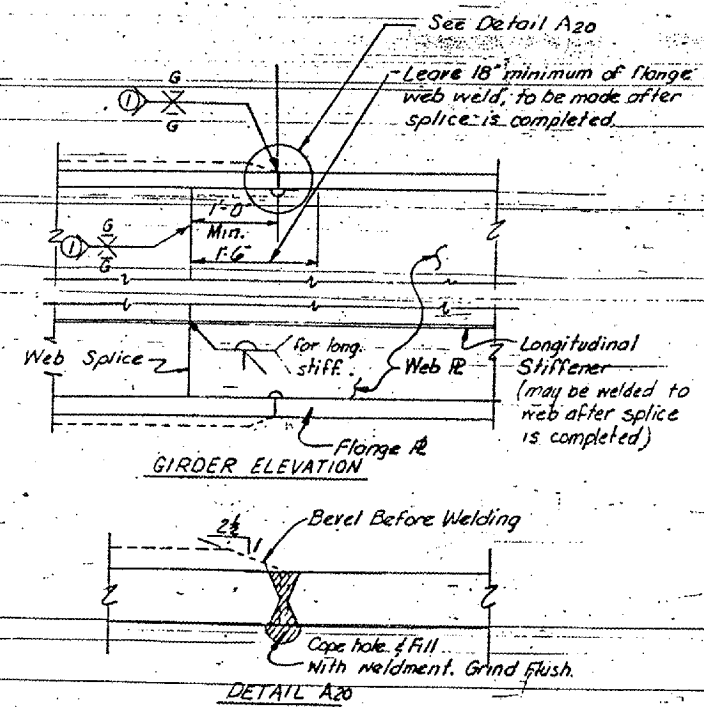
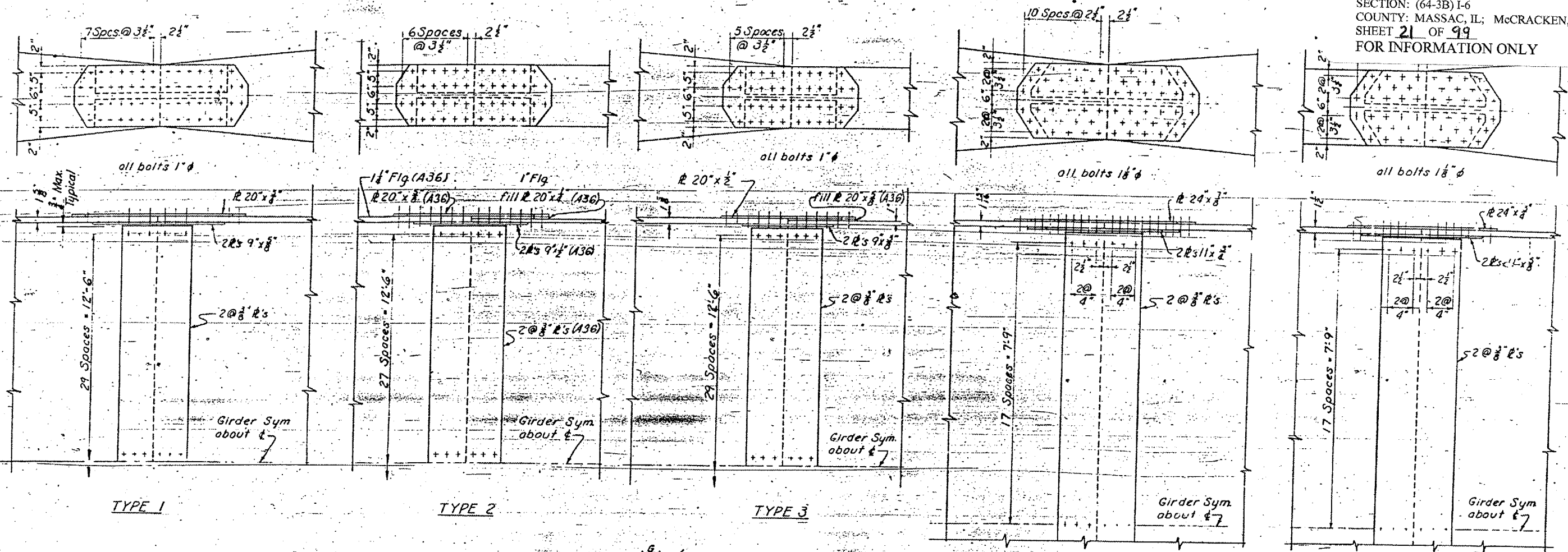

TYPICAL YARD SPLICE DETAIL

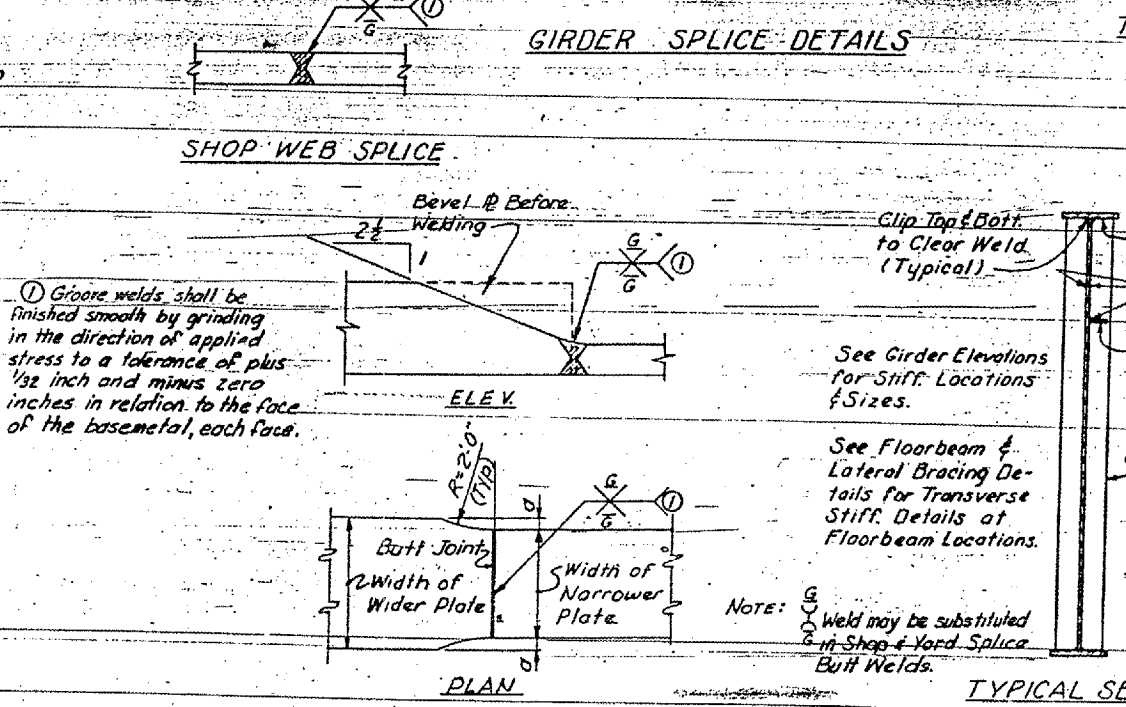

SHOP WEB SPLICE
 SHOP FLANGE SPLICE TRANSITION
 (Except for tapered plates)

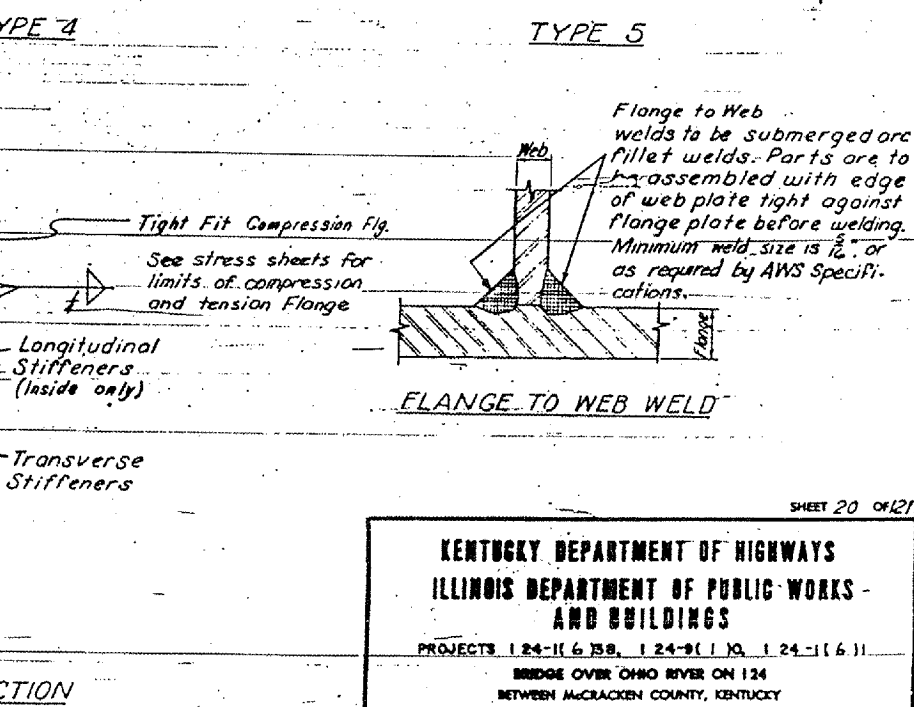

TYPICAL SECTION
 ALL GIRDS
 GIRDER SPLICE DETAILS
 STRUCTURAL STEEL

① Groove welds shall be finished smooth by grinding in the direction of applied stress to a tolerance of plus 1/8 inch and minus zero inches in relation to the face of the base metal, each face.

NOTE: G Weld may be substituted in Shop & Yard Splice But Welds.

See stress sheets for limits of compression and tension Flange

Flange to Web welds to be submerged arc fillet welds. Parts are to be assembled with edge of web plate tight against flange plate before welding. Minimum weld size is 1/4" or as required by AWS Specifications.

DESIGNED BY: CHANDLER
 CHECKED BY: G.B. SACHS
 ENGINEER: C.H.H.
 DATE: 4-62

KENTUCKY DEPARTMENT OF HIGHWAYS ILLINOIS DEPARTMENT OF PUBLIC WORKS AND BUILDINGS PROJECTS 124-116158, 124-9(10), 124-11611 BRIDGE OVER OHIO RIVER ON 124 BETWEEN McCRACKEN COUNTY, KENTUCKY AND MASSAC COUNTY, ILLINOIS			
HAZLET & BRIDAL Consulting Engineers File No. 245	BRIDGE NUMBER	DRAWING NO. 17471	INDEX

SHEET 20 OF 21

CONTRACT: 98990
 ROUTE: INTERSTATE 24
 SECTION: (64-3B) I-6
 COUNTY: MASSAC, IL; McCracken, KY
 SHEET 22 OF 99
 FOR INFORMATION ONLY

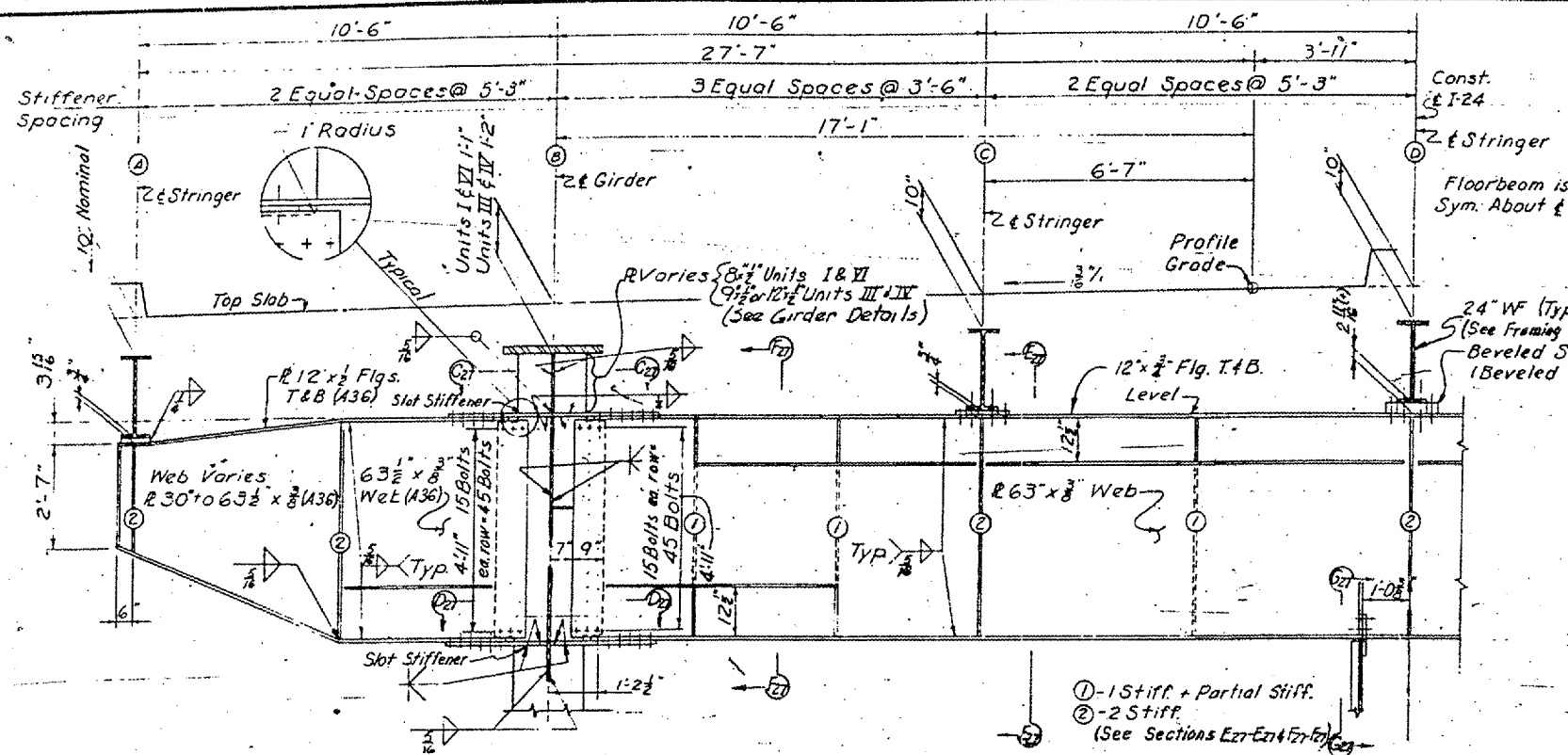

TYPE 1 FLOORBEAM

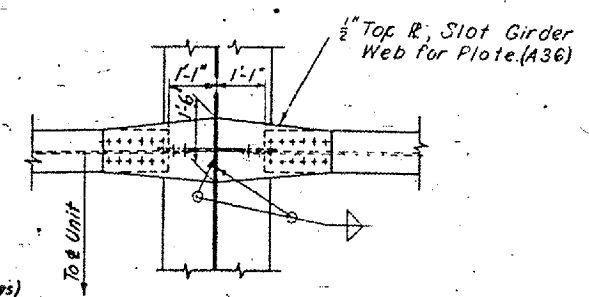

SECTION C27-C27

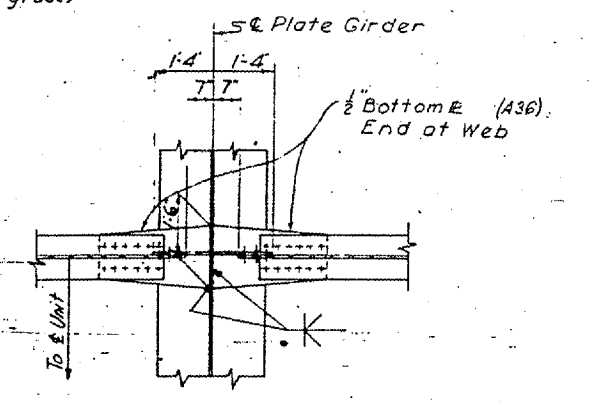

SECTION D27-D27

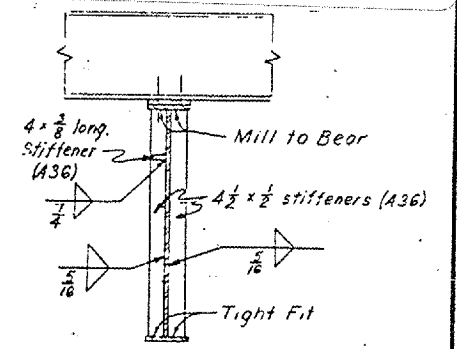

SECTION E27-E27 (2)
(Typ at Stringers)

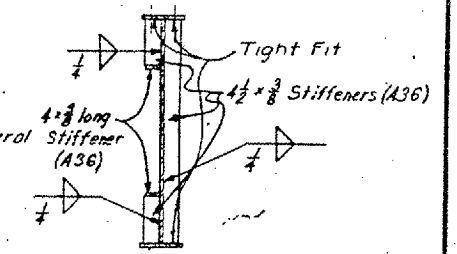

SECTION F27-F27 (10)
(Typ Between Stringers)

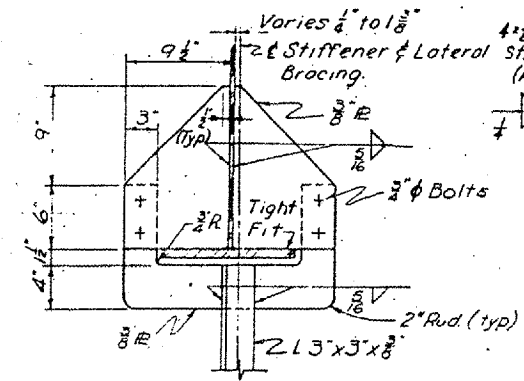

SECTION G27-G27
(Typ All Floorbeams in Units I, III, IV, & VI)

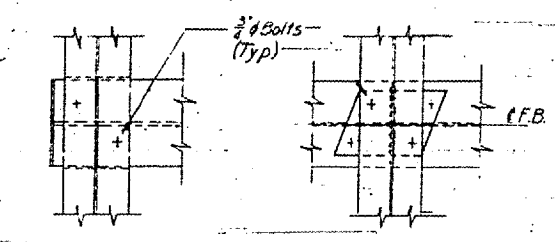

PLAN BRG. @ A PLAN BRG. @ C & D

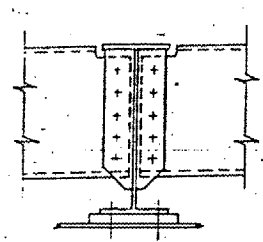

VIEW R27-R27
(VIEW T27-T27 Similar)

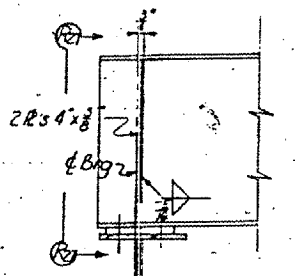

STRINGER DETAIL @ CELL B

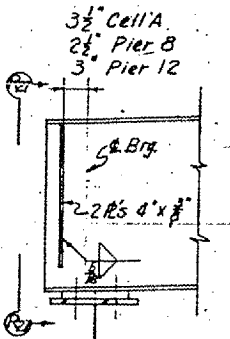

STRINGER DETAIL @ CELL A
& PIERS 8 & 12

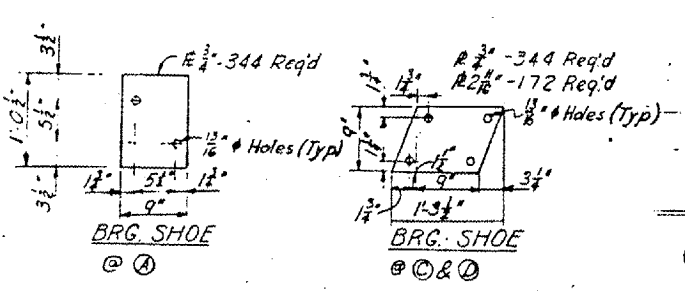

Note: All bearing shoes to be A36 steel.

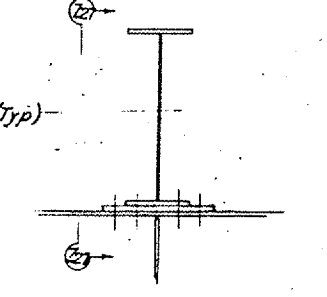

STRINGER BRG. DETAIL

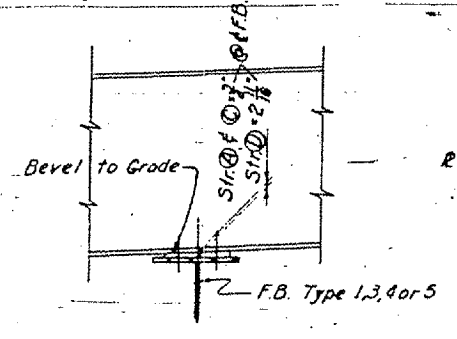

SECTION Z27-Z27

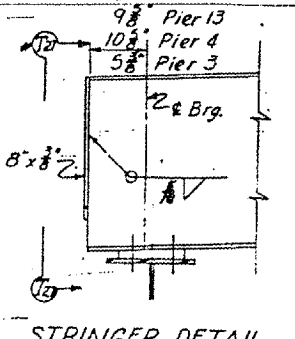

STRINGER DETAIL @ PIERS 3, 4 & 13

Type	(A)	(B)	(C)	(D)
(1)	1/8"	Girder	8"	8"
(2) & (6)	0"	Girder	1/8"	1/8"
(3) & (5)	1/8"	Girder	8"	8"

FLOORBEAM CAMBER DIAGRAM

FLOORBEAM & STRINGER SHOES
 STRUCTURAL STEEL

KENTUCKY DEPARTMENT OF HIGHWAYS
 ILLINOIS DEPARTMENT OF PUBLIC WORKS
 AND BUILDINGS
 PROJECTS 124-116-138, 124-91130, 124-116-111
 BRIDGE OVER OHIO RIVER ON 124
 BETWEEN McCracken COUNTY, KENTUCKY
 AND MASSAC COUNTY, ILLINOIS

HAZLET & ENDAL Consulting Engineers File No. 888
 BRIDGE NUMBER
 DRAWING NO. 17471
 INDEX

DRAWING NO. 17471
 SHEET 22 OF 99
 CONTRACT 98990
 ROUTE INTERSTATE 24
 SECTION (64-3B) I-6
 COUNTY MASSAC, IL; McCracken, KY
 PROJECTS 124-116-138, 124-91130, 124-116-111
 BRIDGE OVER OHIO RIVER ON 124
 BETWEEN McCracken COUNTY, KENTUCKY
 AND MASSAC COUNTY, ILLINOIS
 HAZLET & ENDAL Consulting Engineers File No. 888
 BRIDGE NUMBER
 DRAWING NO. 17471
 INDEX

CONTRACT: 98990
 ROUTE: INTERSTATE 24
 SECTION: (64-3B) I-6
 COUNTY: MASSAC, IL; McCRACKEN, KY
 SHEET 23 OF 99
 FOR INFORMATION ONLY

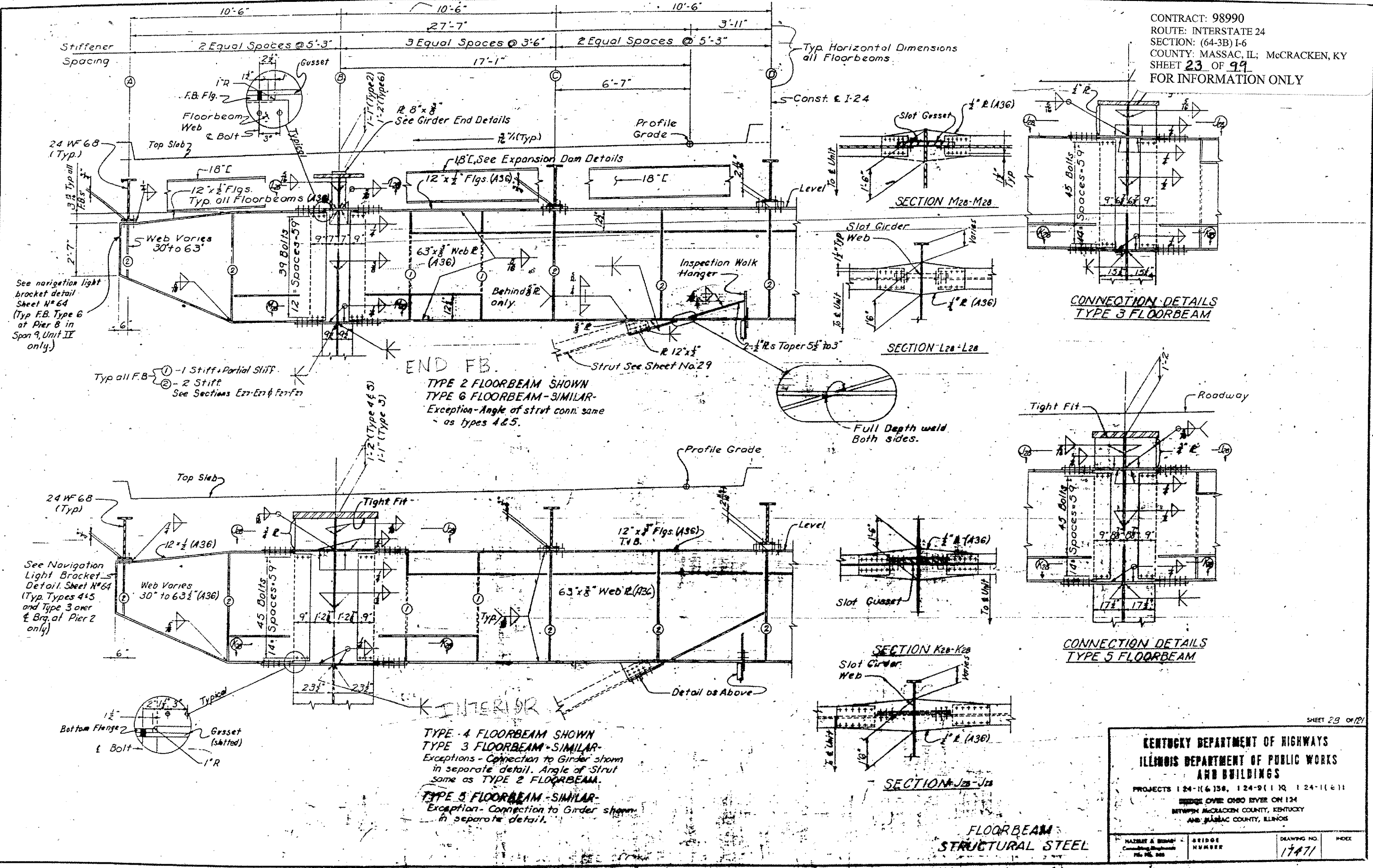

DRAWN BY: CHH
 CHECKED BY: CHH
 DATE: 4-68
 PROJECT: INTERSTATE 24
 SHEET: 23 OF 99

SHEET 23 OF 99

**KENTUCKY DEPARTMENT OF HIGHWAYS
 ILLINOIS DEPARTMENT OF PUBLIC WORKS
 AND BUILDINGS**

PROJECTS 124-1(6)158, 124-9(1)10, 124-1(6)11
 BRIDGE OVER OSBO RIVER ON I24
 BETWEEN McCRACKEN COUNTY, KENTUCKY
 AND JEFFERSON COUNTY, ILLINOIS

HAZLET & BROWN Consulting Engineers P.O. Box 288	BRIDGE NUMBER	DRAWING NO. 17471	INDEX
--	------------------	----------------------	-------



CONTRACT: 98990
 ROUTE: INTERSTATE 24
 SECTION: (64-3B) I-6
 COUNTY: MASSAC, IL; McCracken, KY
 SHEET 24 OF 99
 FOR INFORMATION ONLY

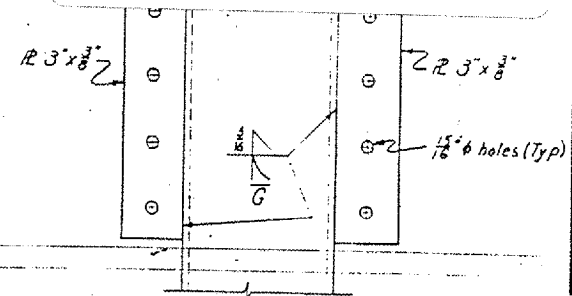
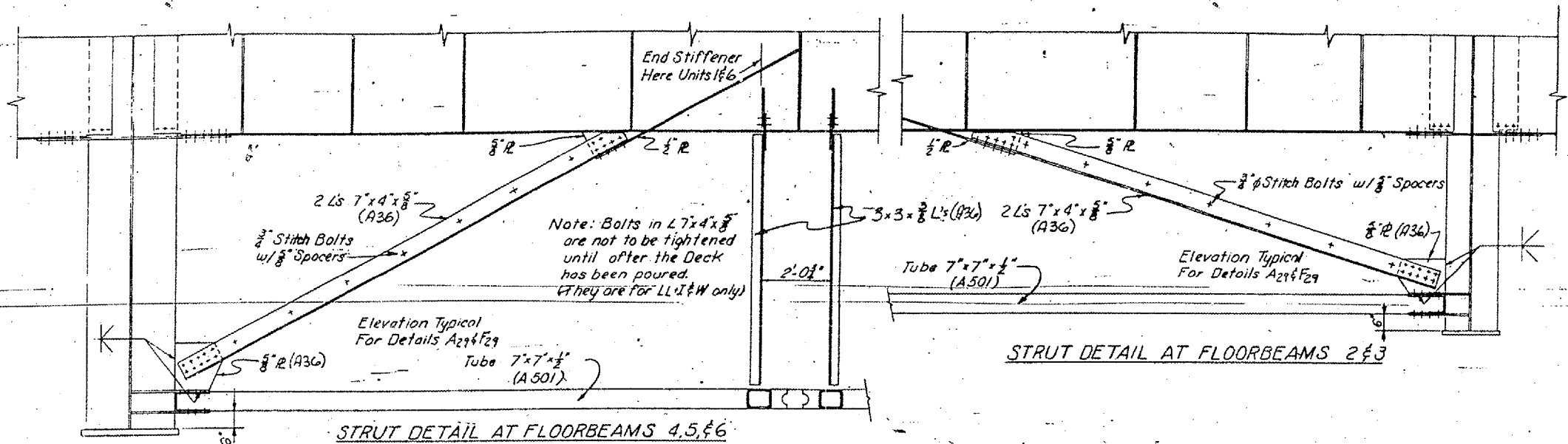
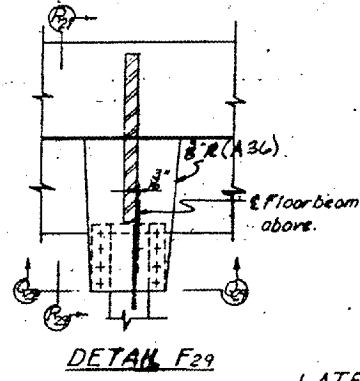
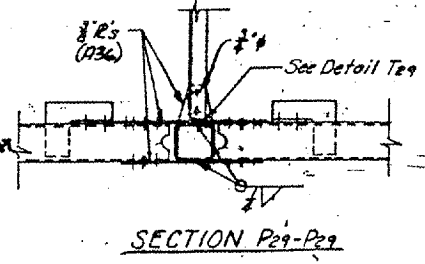
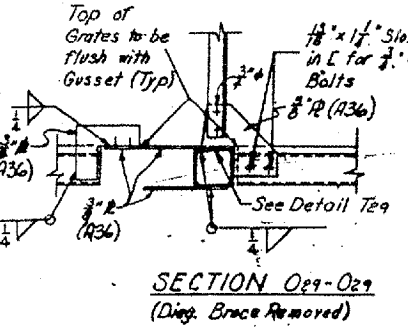
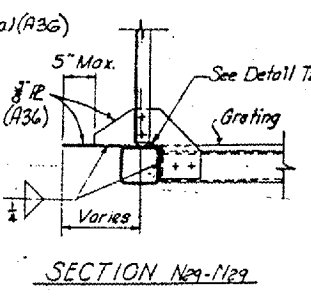
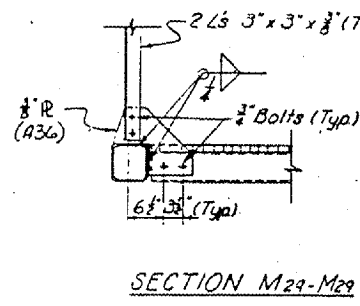
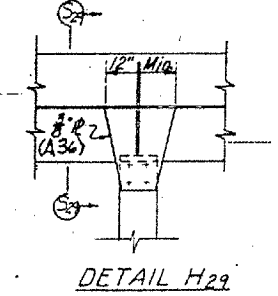
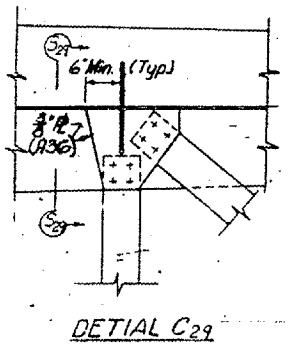
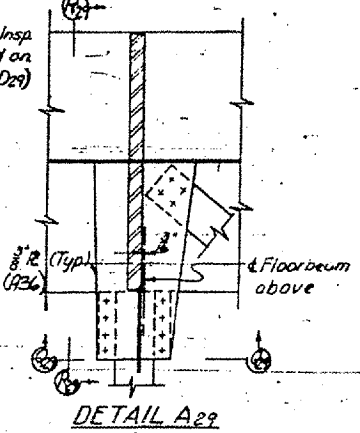
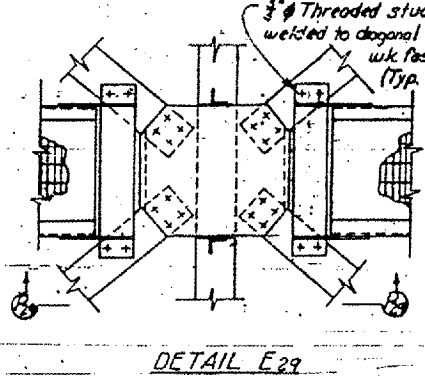
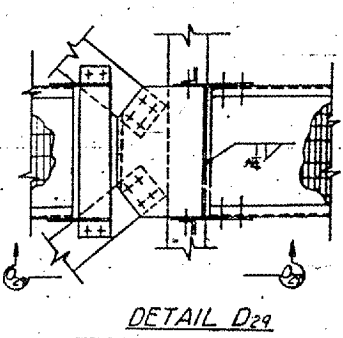
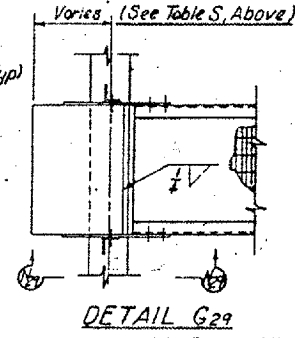
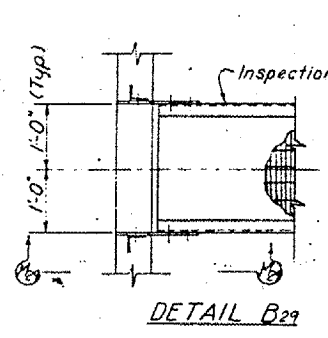
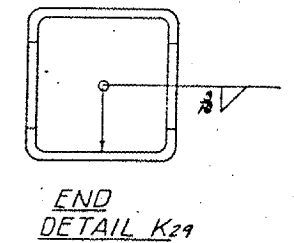
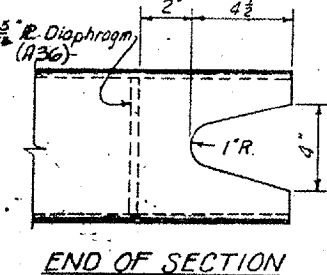
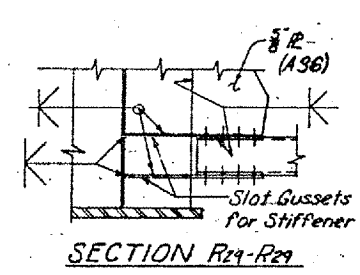
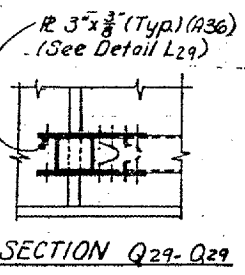
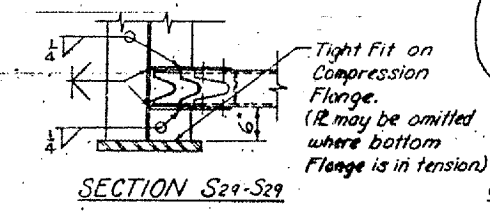
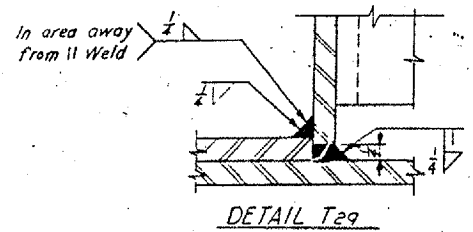

TABLE S

Unit	Piec.	Dist.
I	3	2'-0"
III	4	2'-0"
III & IV	8	1'-3"
IV	12	2'-0"
VI	13	2'-0"



LATERAL BRACING
 STRUCTURAL STEEL

KENTUCKY DEPARTMENT OF HIGHWAYS
 ILLINOIS DEPARTMENT OF PUBLIC WORKS
 AND BUILDINGS
 PROJECTS 124-1(6)138, 124-9(1)10, 124-1(6)11
 BRIDGE OVER OHIO RIVER ON I24
 BETWEEN McCRACKEN COUNTY, KENTUCKY
 AND MASSAC COUNTY, ILLINOIS

HAZLET & ERDAL
 Consulting Engineers
 P.E. No. 288

BRIDGE
 NUMBER

DRAWING NO.
 17471

INDEX

DRAWN BY: J.A.S./M.L. CHECKED BY: C.H.M. DATE: 4-68
 REVISION: 1. DATE: 4-68
 2. DATE: 4-68
 3. DATE: 4-68
 4. DATE: 4-68
 5. DATE: 4-68
 6. DATE: 4-68
 7. DATE: 4-68
 8. DATE: 4-68
 9. DATE: 4-68
 10. DATE: 4-68
 11. DATE: 4-68
 12. DATE: 4-68
 13. DATE: 4-68
 14. DATE: 4-68
 15. DATE: 4-68
 16. DATE: 4-68
 17. DATE: 4-68
 18. DATE: 4-68
 19. DATE: 4-68
 20. DATE: 4-68
 21. DATE: 4-68
 22. DATE: 4-68
 23. DATE: 4-68
 24. DATE: 4-68

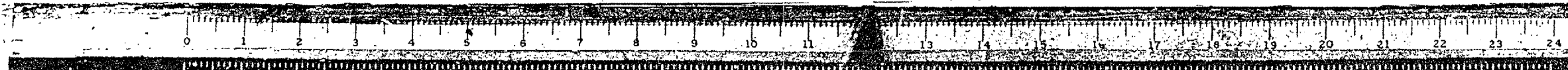

CONTRACT: 98990
 ROUTE: INTERSTATE 24
 SECTION: (64-3B)1-6
 COUNTY: MASSAC, IL; McCRACKEN, KY
 SHEET 25 OF 99
 FOR INFORMATION ONLY

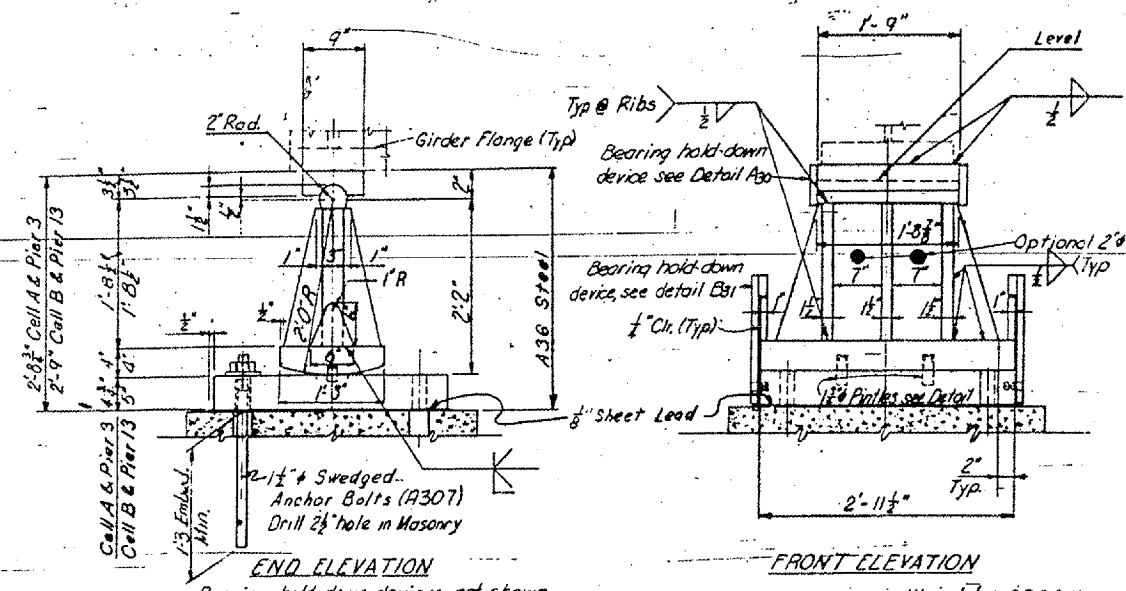

FRONT ELEVATION

END ELEVATION
 Bearing hold-down devices not shown

Weight - 2968 lbs
 Reaction - 706 K
 Cell A & Pier 3

Weight - 3254 lbs
 Reaction - 706 K
 Pier 13 & Cell B

PLAN BOTTOM PLATE

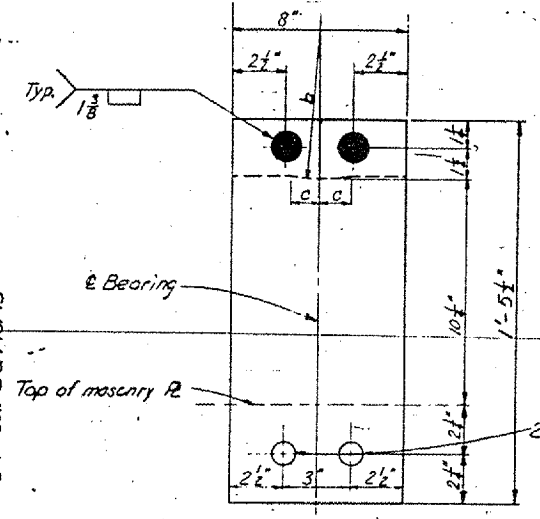

FRONT ELEV

END VIEW

DETAIL B31
 Exp. Bearing hold-down device

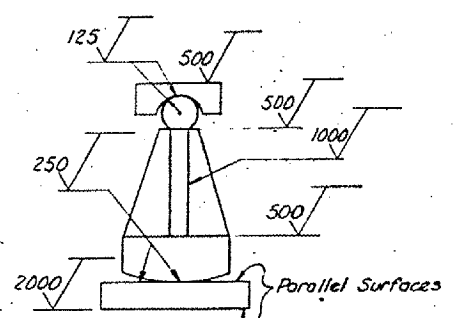

TYPICAL PIN TO WEB CONNECTION
 AT ALL SHOES

KEY TO FINISHED SURFACES, ALL EXP. BRGS.
 See KDH Specs. Sec. 408.3.1-H3 2" Rad.

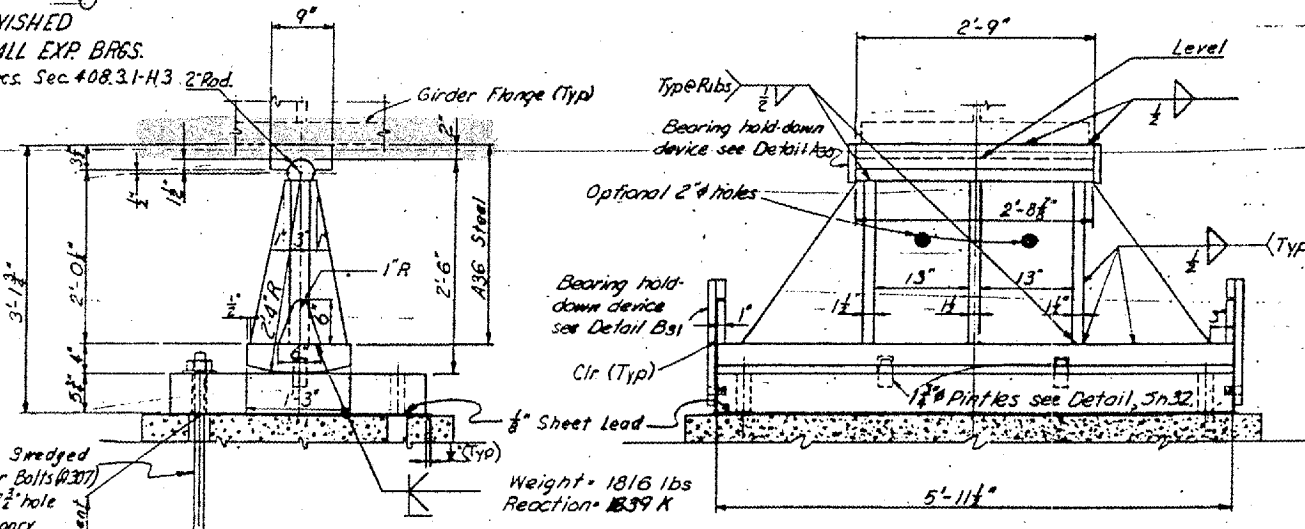

FRONT ELEVATION

END ELEVATION
 Bearing hold-down devices not shown

BEARING TYPE E2
 USE AT PIERS 14 & 18
 4 REQUIRED

Weight - 1816 lbs
 Reaction - 1339 K

	TYPE		
	E1	E2	E3 or E4
b	6 3/8"	7 3/8"	5 1/2"
c	2 3/8"	1 1/4"	1 3/4"

Table for Detail B31

Temp. Br.	-20"	0"	20"	40"	60"	80"	100"	120"
A	1.66"	1.24"	.83"	.41"	0	.41"	.83"	1.24"
3	2.01"	1.51"	1.01"	.50"	0	.50"	1.01"	1.51"
13	3.83"	2.87"	1.92"	.96"	0	.96"	1.92"	2.87"
14	2.58"	1.94"	1.29"	.64"	0	.64"	1.29"	1.94"
18	2.41"	1.81"	1.20"	.61"	0	.61"	1.20"	1.81"
B	3.66"	2.74"	1.83"	.91"	0	.91"	1.83"	2.74"

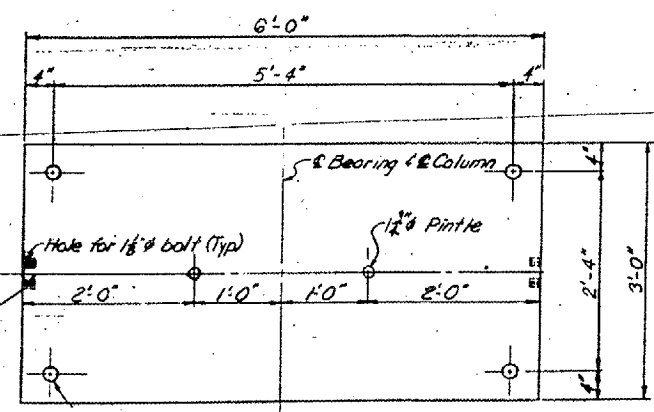

PLAN BOTTOM PLATE

EXPANSION BEARINGS
 STRUCTURAL STEEL

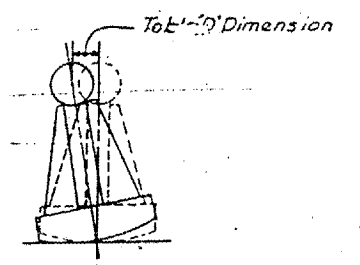

KENTUCKY DEPARTMENT OF HIGHWAYS
 ILLINOIS DEPARTMENT OF PUBLIC WORKS
 AND BUILDINGS

PROJECTS 124-1(6)30, 124-9(1)10, 124-11(6)1
 BRIDGE OVER OHIO RIVER ON 124
 BETWEEN McCRACKEN COUNTY, KENTUCKY
 AND MASSAC COUNTY, ILLINOIS

HAZLET & ERDMAN
 Consulting Engineers
 PLS. No. 888

BRIDGE NUMBER

DRAWING NO. 17471

INDEX

REVISION: Finished Surface Symbol DATE 4/5/97
 CHECKED BY: C.H.H. DATE 4/5/97
 CHECKED BY: C.H.H. DATE 4/5/97
 DRAWN BY: D.B. DATE 4/5/97
 CHECKED BY: C.H.H. DATE 4/5/97

CONTRACT: 98990
 ROUTE: INTERSTATE 24
 SECTION: (64-3B) 1-6
 COUNTY: MASSAC, IL; McCRACKEN, KY
 SHEET 26 OF 99
 FOR INFORMATION ONLY

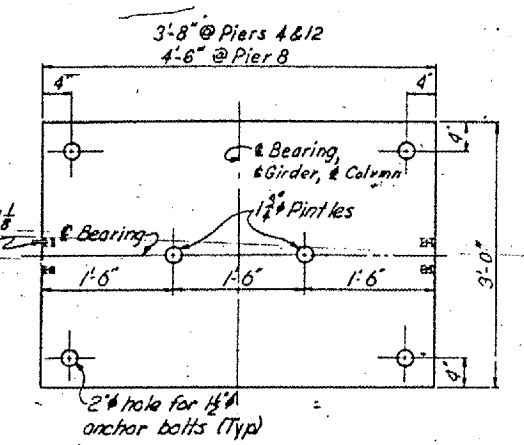
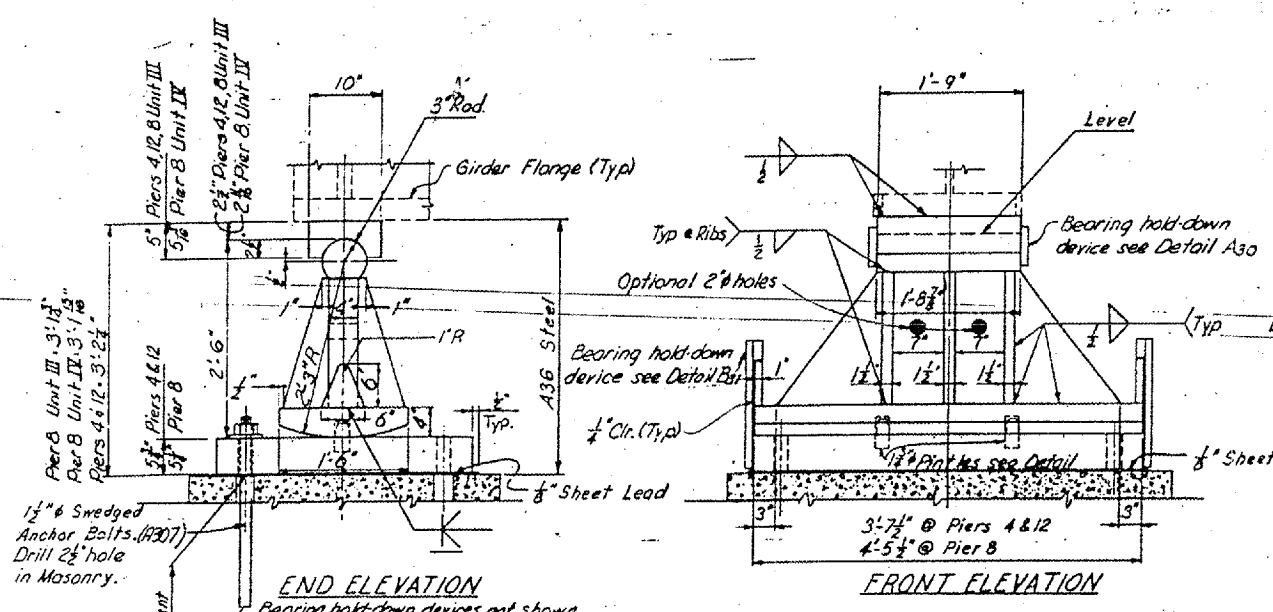
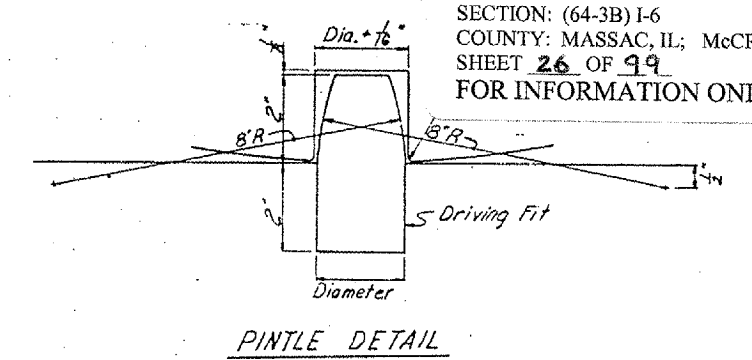

END ELEVATION
 Bearing hold-down devices not shown

FRONT ELEVATION
 Weight - 4875 lbs
 Reaction - 1046 K
 Piers 4 & 12

BEARING TYPE E3
 USE AT PIERS 4, 8 & 12
 8 REQUIRED

TABLE E for SETTING EXPANSION SHOES

Temp. Rise	-20°	0°	20°	40°	60°	80°	100°	120°
4	2.81'	2.12'	1.41'	.70'	0	.70'	1.41'	2.12'
7	2.81'	2.12'	1.41'	.70'	0	.70'	1.41'	2.12'
8 III	4.68'	3.51'	2.34'	1.17'	0	1.17'	2.34'	3.51'
8 IV	4.68'	3.51'	2.34'	1.17'	0	1.17'	2.34'	3.51'
9	2.81'	2.12'	1.41'	.70'	0	.70'	1.41'	2.12'
12	2.81'	2.12'	1.41'	.70'	0	.70'	1.41'	2.12'

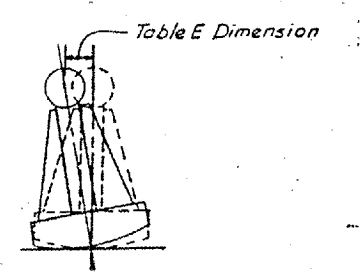

NOTE:
 For Surface Finishes see Sh. U² 31

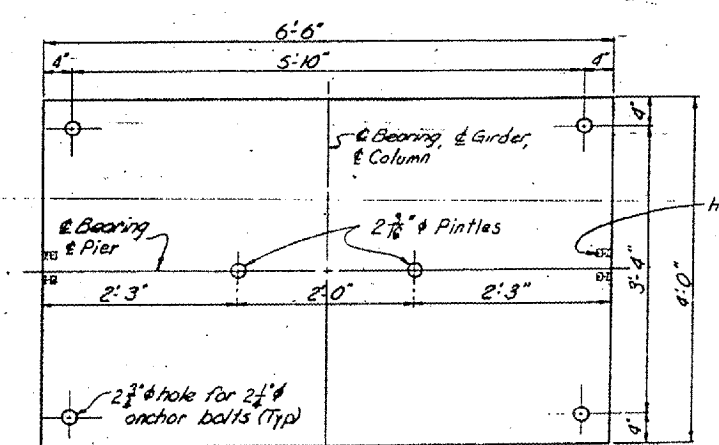
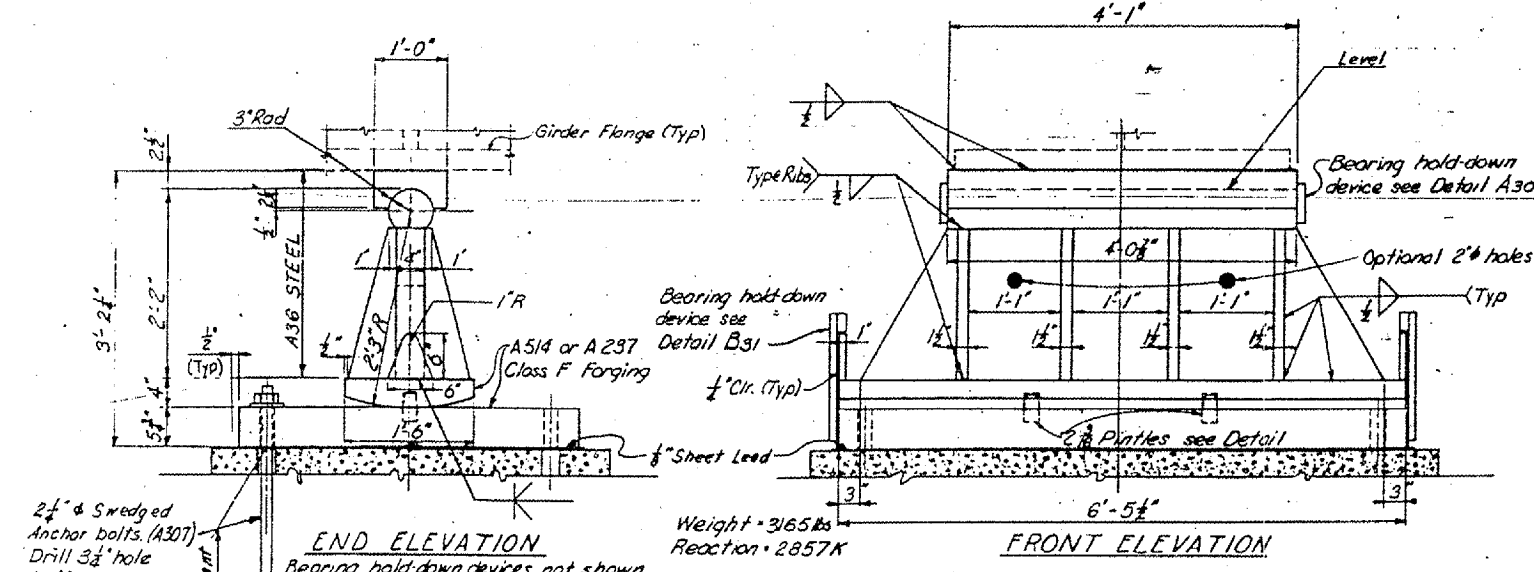

END ELEVATION
 Bearing hold-down devices not shown

FRONT ELEVATION
 Weight - 3165 lbs
 Reaction - 2857 K

BEARING TYPE E4
 USE AT PIERS 7 & 9
 4 REQUIRED

EXPANSION BEARINGS
 STRUCTURAL STEEL

KENTUCKY DEPARTMENT OF HIGHWAYS
 ILLINOIS DEPARTMENT OF PUBLIC WORKS
 AND BUILDINGS

PROJECTS 124-11(6)38, 124-9(1)10, 124-11(6)11
 BRIDGE OVER OHIO RIVER ON 124
 BETWEEN McCRACKEN COUNTY, KENTUCKY
 AND MASSAC COUNTY, ILLINOIS

HAZLET & ERDAL
 Consulting Engineers
 File No. 228

BRIDGE
 NVA 228

DRAWING NO.
 17471

INDEX

DRAWN BY: CHY
 CHECKED BY: JCS
 DATE: 11/67
 SCALE: 1/4" = 1'-0"
 SHEET 26 OF 99

CONTRACT: 98990
 ROUTE: INTERSTATE 24
 SECTION: (64-3B) I-6
 COUNTY: MASSAC. IL; McCracken, KY
 SHEET 27 OF 99
 FOR INFORMATION ONLY

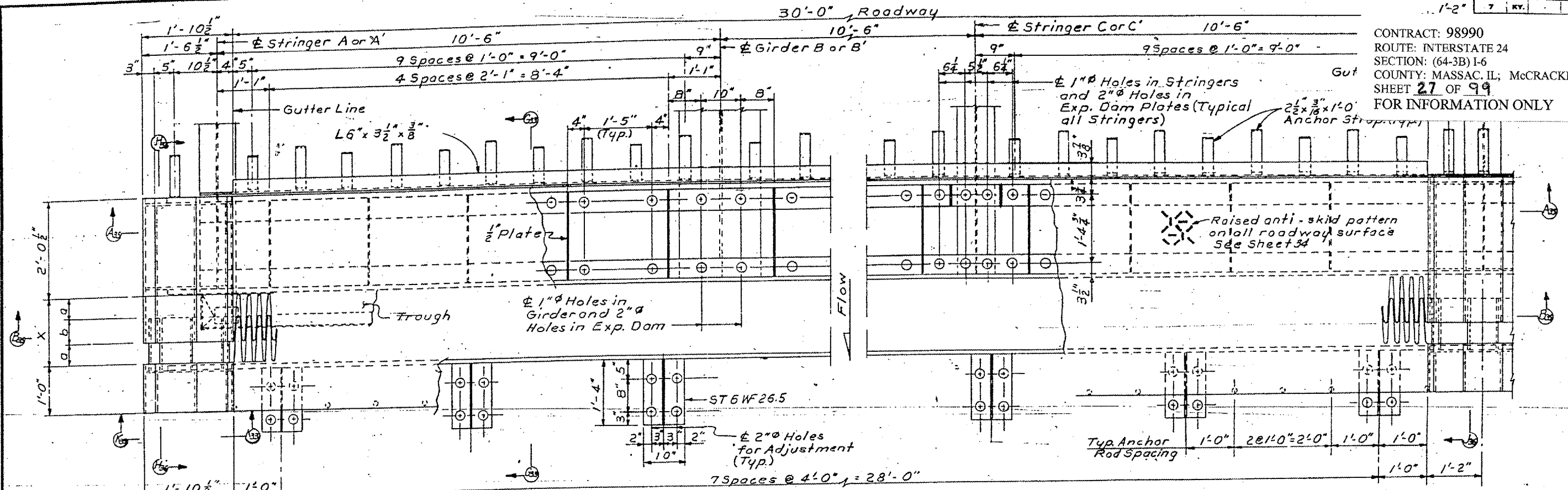

PLAN

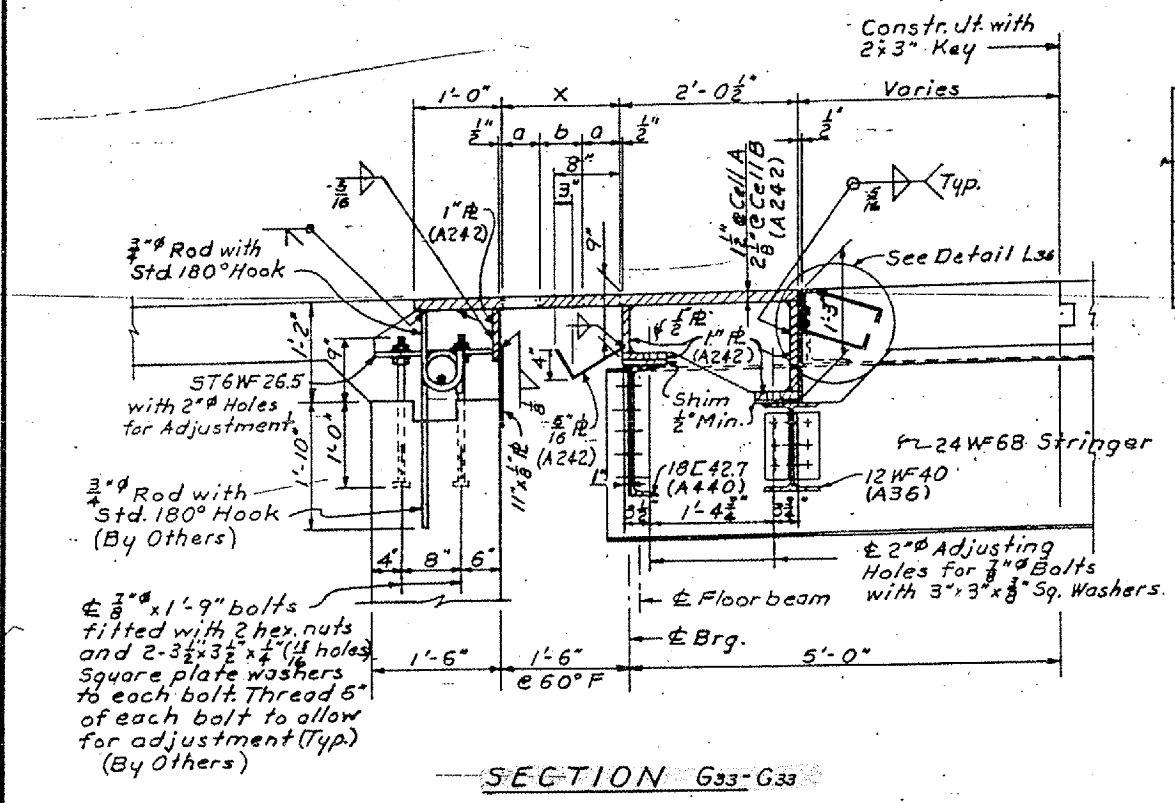

DIMENSION AT TEMPERATURE (F)

LOCATION	-20°			0°			20°			40°			60°			80°			-100°			120°		
	a	b	x	a	b	x	a	b	x	a	b	x	a	b	x	a	b	x	a	b	x			
CELL-A	5 3/8"	2 3/8"	1'-2 3/8"	5 3/8"	3 3/8"	1'-1 3/8"	4 15/16"	3 9/16"	1'-1 1/8"	4 1/2"	4	1'-1"	4"	4 1/2"	1'-0 1/2"	3 1/2"	5"	1'-0"	3 1/8"	5 7/8"	11 1/8"	2 3/8"	5 1/8"	11 1/8"
CELL-B	9"	2 1/2"	1'-8 1/2"	8 1/2"	3 1/8"	1'-7 1/8"	7 3/8"	4 3/8"	1'-6 3/8"	6 1/16"	5 1/16"	1'-5 1/16"	5 1/4"	6 1/4"	1'-4 1/4"	4 7/8"	7 1/8"	1'-3 1/8"	3 3/8"	8 1/8"	1'-2 3/8"	2 7/8"	9 1/8"	1'-1 1/8"

EXPANSION DAM WEIGHT
 CELL A 34,758 Lbs.
 CELL B 41,676 Lbs.

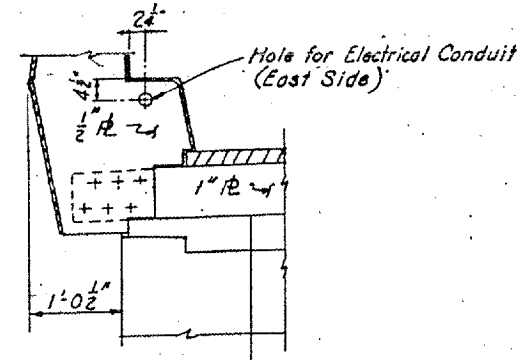

EXPANSION DAMS
 AT CELLS A & B
 STRUCTURAL STEEL

KENTUCKY DEPARTMENT OF HIGHWAYS
 ILLINOIS DEPARTMENT OF PUBLIC WORKS
 AND BUILDINGS

PROJECTS 124-1(6)38, 124-9(1)10, 124-1(6)11
 BRIDGE OVER OHIO RIVER ON I24
 BETWEEN MACCRACKEN COUNTY, KENTUCKY
 AND MASSAC COUNTY, ILLINOIS

HAZLET & BRIDAL
 Consulting Engineers
 File No. 808

BRIDGE
 NUMBER

DRAWING NO.
 17471

INDEX

DESIGNED BY: RBS
 CHECKED BY: MDC
 DATE: 10/1/68
 PROJECT: I-24 OVER OHIO RIVER ON I-24
 SHEET: 27 OF 99

CONTRACT: 98990
 ROUTE: INTERSTATE 24
 SECTION: (64-3B) I-6
 COUNTY: MASSAC, IL; McCRACKEN, KY
 SHEET 28 OF 99
 FOR INFORMATION ONLY

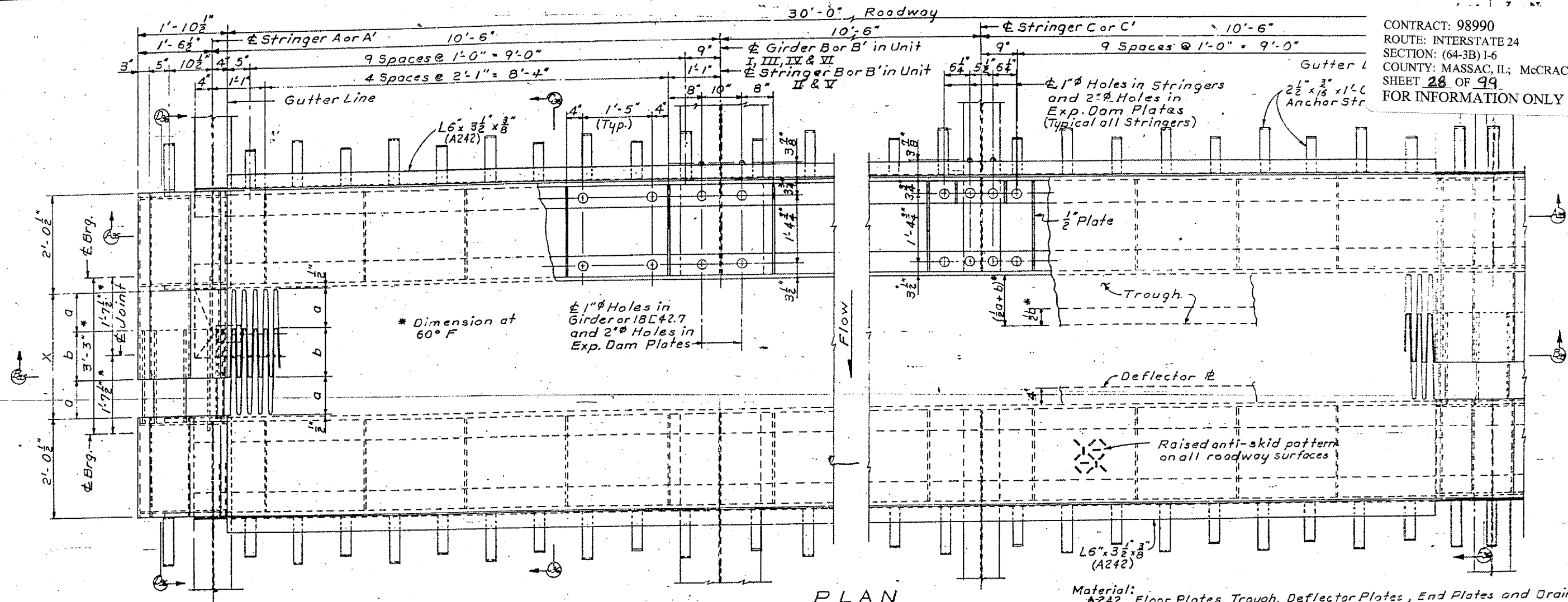

PLAN

LOCATION	DIMENSION AT TEMPERATURE (F)																										
	-20°			0°			20°			40°			60°			80°			100°			120°					
	a	b	x	a	b	x	a	b	x	a	b	x	a	b	x	a	b	x	a	b	x	a	b	x	a	b	x
PIER No. 3	1'-2 5/8"	2 7/8"	2'-7 1/8"	1'-0 13/16"	3 5/8"	2'-5 3/8"	11 3/8"	5 3/8"	2'-4 3/8"	9 5/8"	6 1/8"	2'-2 1/8"	8 1/2"	8 1/4"	2'-1 1/4"	7 1/8"	9 1/8"	1'-11 1/8"	5 9/8"	11 3/8"	1'-10 5/8"	4 3/8"	1'-0 5/8"	1'-8 7/8"			
PIER No. 4	7 3/8"	2 7/8"	1'-5 3/8"	6 13/16"	3 3/8"	1'-4 13/16"	6 3/8"	3 3/8"	1'-4 3/8"	5 1/8"	4 7/8"	1'-3 7/8"	4 3/4"	5 1/4"	1'-2 3/4"	4 7/8"	5 5/8"	1'-2 1/8"	3 5/8"	6 1/8"	1'-1 5/8"	2 3/8"	7 3/8"	1'-0 3/8"			
PIER No. 8	1'-6 3/8"	2 5/8"	3'-4 3/8"	1'-4 1/2"	5"	3'-2"	1'-2 1/4"	7 1/4"	2'-11 3/4"	11 3/8"	9 5/8"	2'-9 5/8"	9 1/2"	12"	2'-7"	7 3/8"	1'-2 3/8"	2'-4 3/8"	4 13/16"	1'-4 1/8"	2'-2 1/8"	2 7/8"	1'-7 1/8"	1'-11 1/8"			
PIER No. 12	1'-5 3/8"	2 5/8"	3'-1 3/8"	1'-3 1/8"	4 1/8"	2'-11 1/8"	1'-1 1/8"	6 5/8"	2'-9 1/8"	11 3/8"	8 3/8"	2'-7 3/8"	10"	10"	2'-6"	8 3/8"	11 3/8"	2'-4 3/8"	6 5/8"	1'-1 1/8"	2'-2 5/8"	4 7/8"	1'-3 7/8"	2'-0 7/8"			
PIER No. 13	9"	2 1/2"	1'-8 1/2"	8 1/8"	3 1/8"	1'-7 3/8"	7 3/8"	4 3/8"	1'-6 3/8"	6 3/8"	5 1/8"	1'-5 1/8"	5 1/4"	6 1/4"	1'-4 1/4"	4 5/8"	7 1/8"	1'-3 1/8"	3 3/8"	8 3/8"	1'-2 3/8"	2 7/8"	9 1/8"	1'-1 1/8"			

Material:
 A242 Floor Plates, Trough, Deflector Plates, End Plates and Drain Pipe.
 See General Notes, Sheet No. 2
 A36 Shims, Stiffening Plates, Parapet, Curb and Median Plates, and other material.
 A325 All bolts shall be 7/8" Diameter high strength bolts unless noted.
 See Standard Specifications Article 408.3.1 H-2 regarding gas cutting of tooled plates. All dimensions for cuts are to centerline of cut. The tooled plates shall be match-marked to maintain the same relative position after cutting.
 Drain Pipe, pipe supports, connections and fittings are to be included in the unit price bid for Drain Pipe.
 Field welding of armored edge support angles shall be performed only after armored edge is completely erected and adjusted for crown and grade.
 Expansion Dams are to be assembled in the shop in their relative erected positions and inspected for fit.
 Painting: Surface in contact with Concrete shall not be painted or oiled. All inaccessible surfaces of the expansion joints and drainage troughs shall be completely field painted before erection.
 Payment: The cost of Expansion Dams shall be included in the lump sum bid for Structural Steel. Such payment shall be complete compensation for all materials, equipment, tools, labor and incidentals to complete the work.

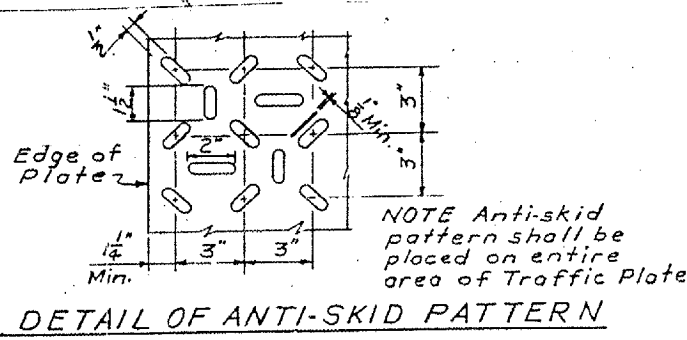
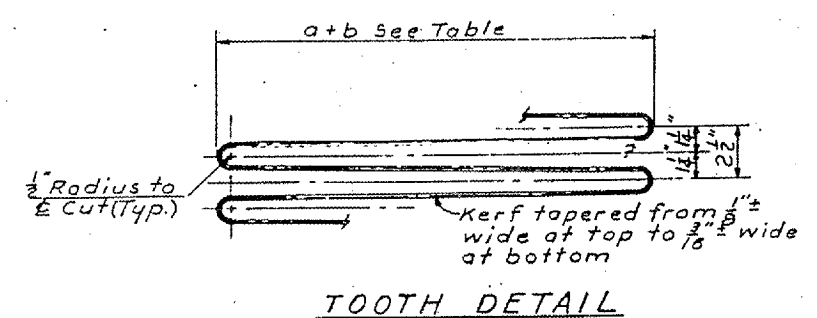

EXPANSION DAMS AT PIERS
 STRUCTURAL STEEL

KENTUCKY DEPARTMENT OF HIGHWAYS
 ILLINOIS DEPARTMENT OF PUBLIC WORKS
 AND BUILDINGS
 PROJECTS I 24-1(6) 38, I 24-9(10), I 24-1(6) 11
 BRIDGE OVER OHIO RIVER ON I 24
 BETWEEN MACCRACKEN COUNTY, KENTUCKY
 AND MASSAC COUNTY, ILLINOIS

HAZLET & BECAL
 Consulting Engineers
 P.O. No. 888

PROJECT NUMBER
 17471

DRAWING NO.
 17471

CONTRACT: 98990
 ROUTE: INTERSTATE 24
 SECTION: (64-3B) I-6
 COUNTY: MASSAC, IL; McCRACKEN, KY
 SHEET 29 OF 99
 FOR INFORMATION ONLY

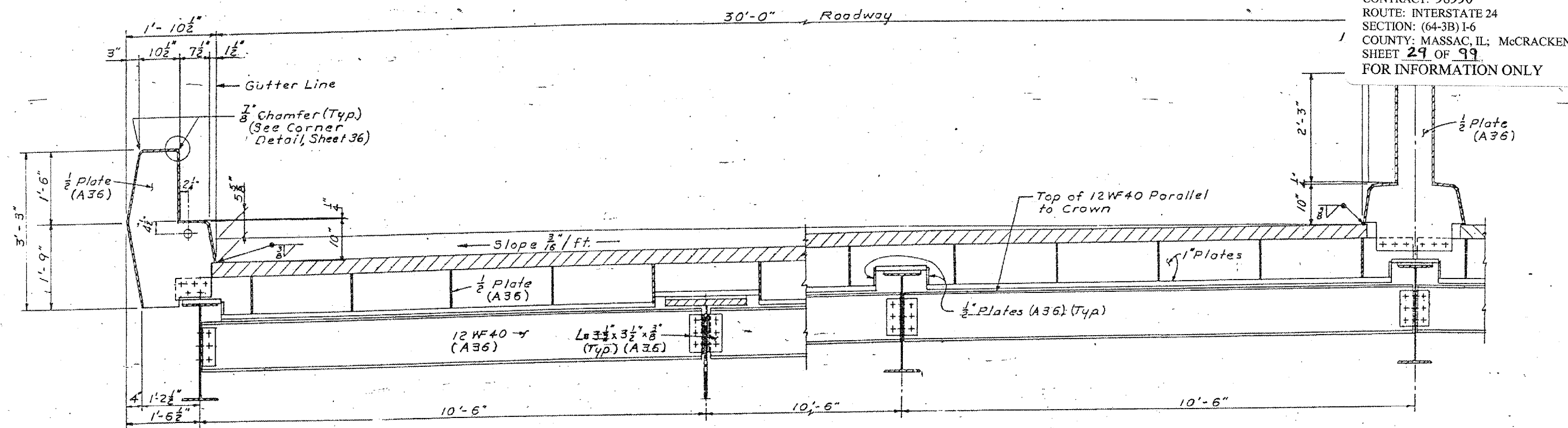

SECTION A35-A35

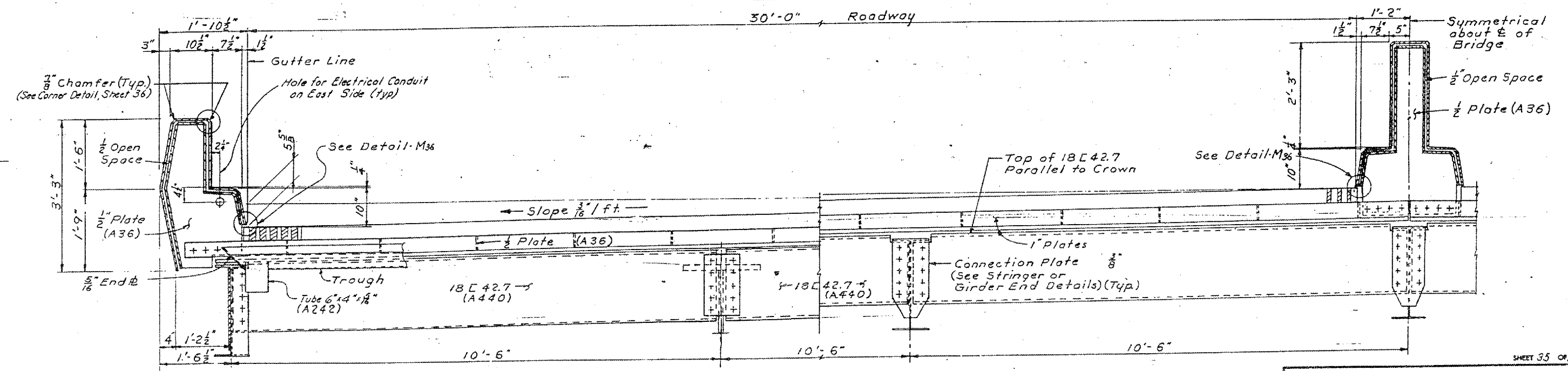

SECTION B35-B35

KENTUCKY DEPARTMENT OF HIGHWAYS
 ILLINOIS DEPARTMENT OF PUBLIC WORKS
 AND BUILDINGS
 PROJECTS I 24-1(6) 38, I 24-9(110), I 24-1(6) 11
 BRIDGE OVER OHIO RIVER ON 124
 BETWEEN McCRACKEN COUNTY, KENTUCKY
 AND MASSAC COUNTY, ILLINOIS

HAZLET & EISAL
 Consulting Engineers
 No. 888

BRIDGE
 NUMBER

DRAWING NO.
 17471

INDEX

EXPANSION DAM SECTIONS
 STRUCTURAL STEEL

DIRECTED BY: ARDC
 CHECKED BY: M.D.C.
 DRAWN BY: R.B.S.
 DATE: 3-10-60
 SCALE: AS SHOWN
 SHEET NO. 29 OF 99

CONTRACT: 98990
 ROUTE: INTERSTATE 24
 SECTION: (64-3B)1-6
 COUNTY: MASSAC, IL; McCRACKEN, KY
 SHEET 30 OF 99
 FOR INFORMATION ONLY

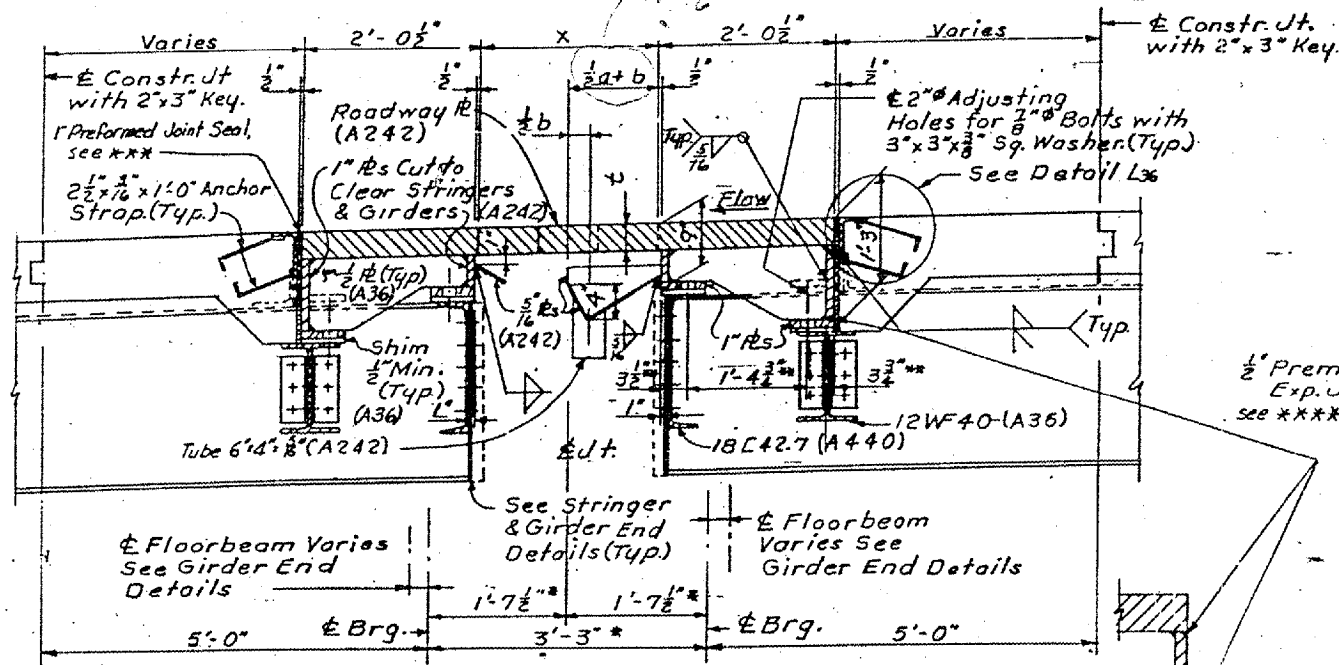

SECTION C36-C36

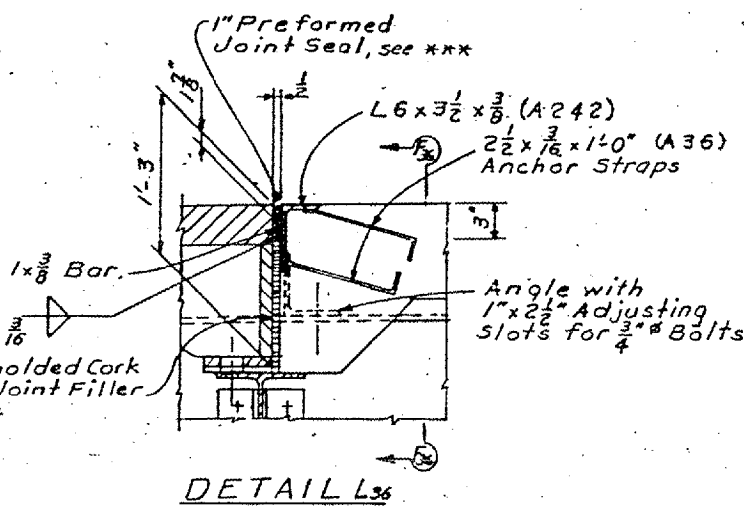

DETAIL L36

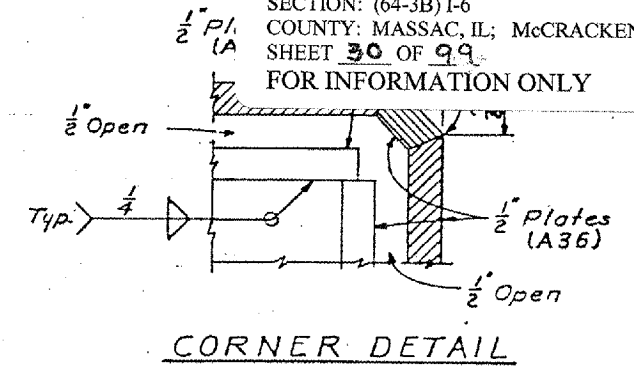

CORNER DETAIL

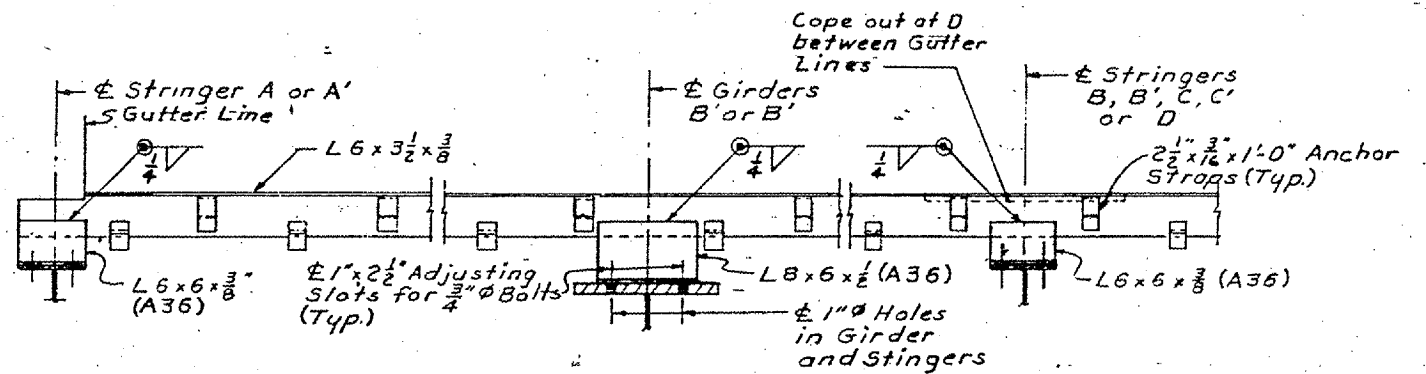

SECTION F36-F36

WELDING DETAIL
(For Expansion Dam Support)

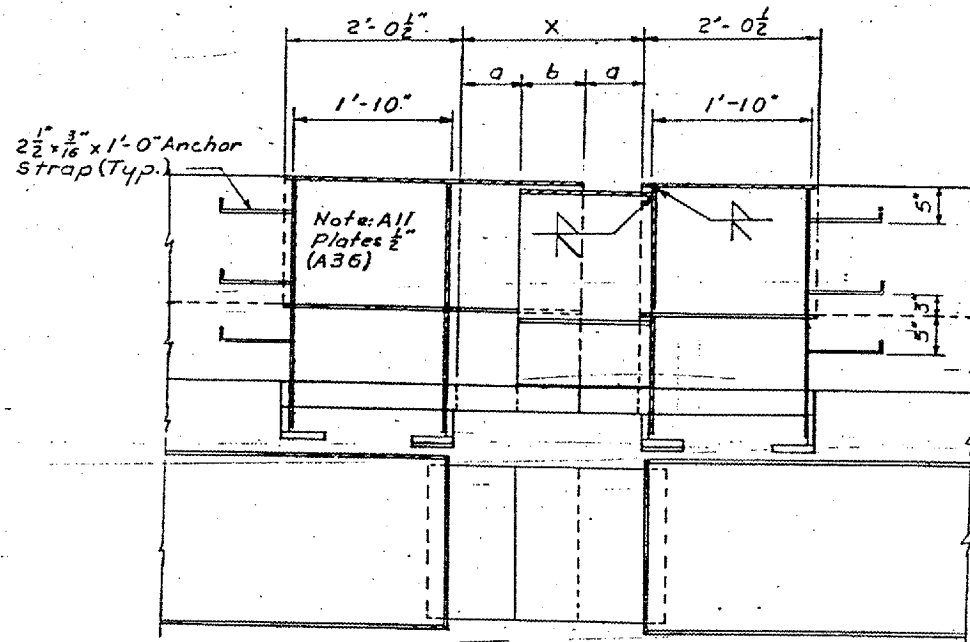

SECTION D36-D36
(SECTION E36-E36 Opposite Hand)

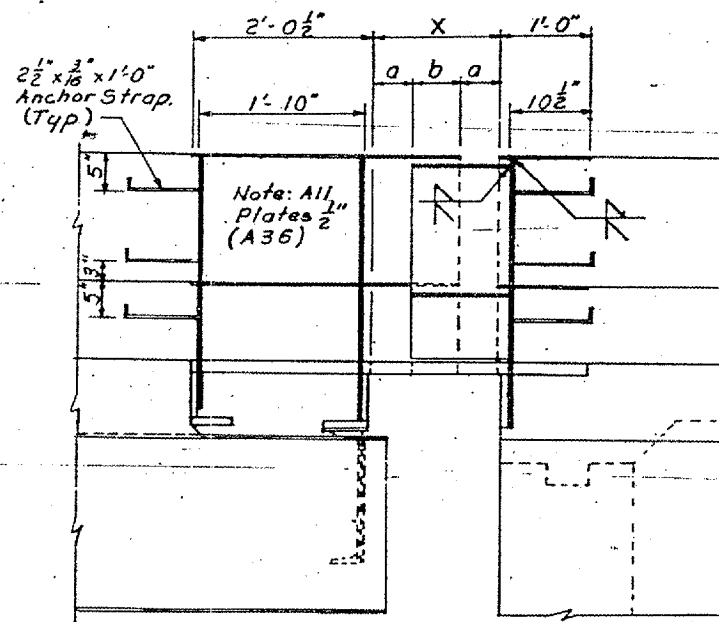

SECTION H36-H36
(SECTION J36-J36 Opposite Hand)

EXPANSION DAM WEIGHTS & LBS.		
PIER No.	PLATE THICKNESS t"	WEIGHT LBS.
PIER No. 3	3"	74,270
PIER No. 4	1 1/2"	55,702
PIER No. 8	3 1/2"	81,558
PIER No. 12	3 1/2"	80,060
PIER No. 13	2 1/2"	60,594

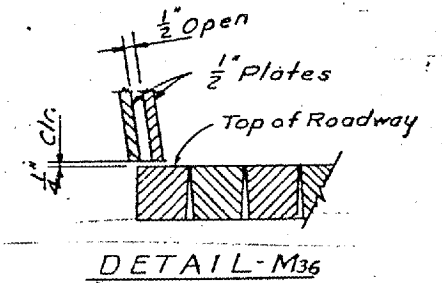

DETAIL M36

Notes:
 * Dimensions at 60°F
 # Symmetrical about &
 See Sheet 34 for a, b & x.
 *** Preformed Joint Seal Details for Concrete Bridge Floors G 353, current edition.
 **** Premolded Cork Expansion Joint Material Details for Concrete Bridge Floors G 354, current edition.

Replace with steel ball
 64-3B-1-6
 98990

EXPANSION DAM DETAILS
 STRUCTURAL STEEL

KENTUCKY DEPARTMENT OF HIGHWAYS
 ILLINOIS DEPARTMENT OF PUBLIC WORKS
 AND BUILDINGS
 PROJECTS 124-116338, 124-9(110), 124-11611
 BRIDGE OVER OHIO RIVER ON 124
 BETWEEN McCRACKEN COUNTY, KENTUCKY
 AND MASSAC COUNTY, ILLINOIS

HAZLET & ENDAL
 Consulting Engineers
 No. 228

BRIDGE
 NUMBER

DRAWING NO.
 17471

INCH

CONTRACT: 98990
 ROUTE: INTERSTATE 24
 SECTION: (64-3B) I-6
 COUNTY: MASSAC. IL; McCracken, KY
 SHEET 31 OF 99
 FOR INFORMATION ONLY

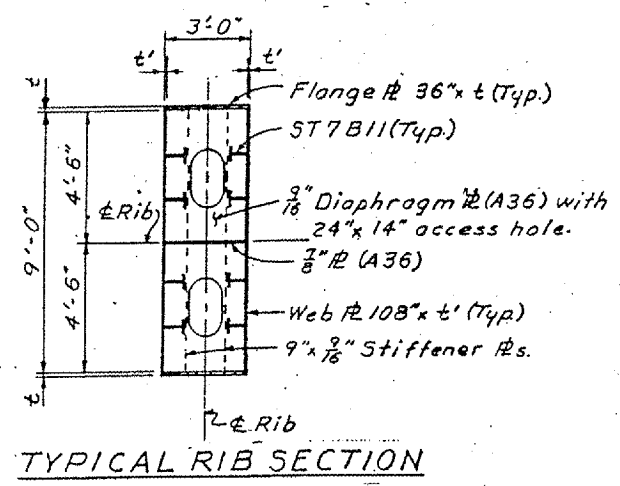

Half Rib Elevation Showing Flange Thickness and Length Plus Diaphragm and Stiffener Location. (Typical each Half.) See Shop Flange Splice - Sheet 20

Half Rib Elevation Showing Web Plate Thickness and Field Splice. Location (Typical Each Half Except for Field Splice @ T9) See Shop Web Splice - Sheet 20

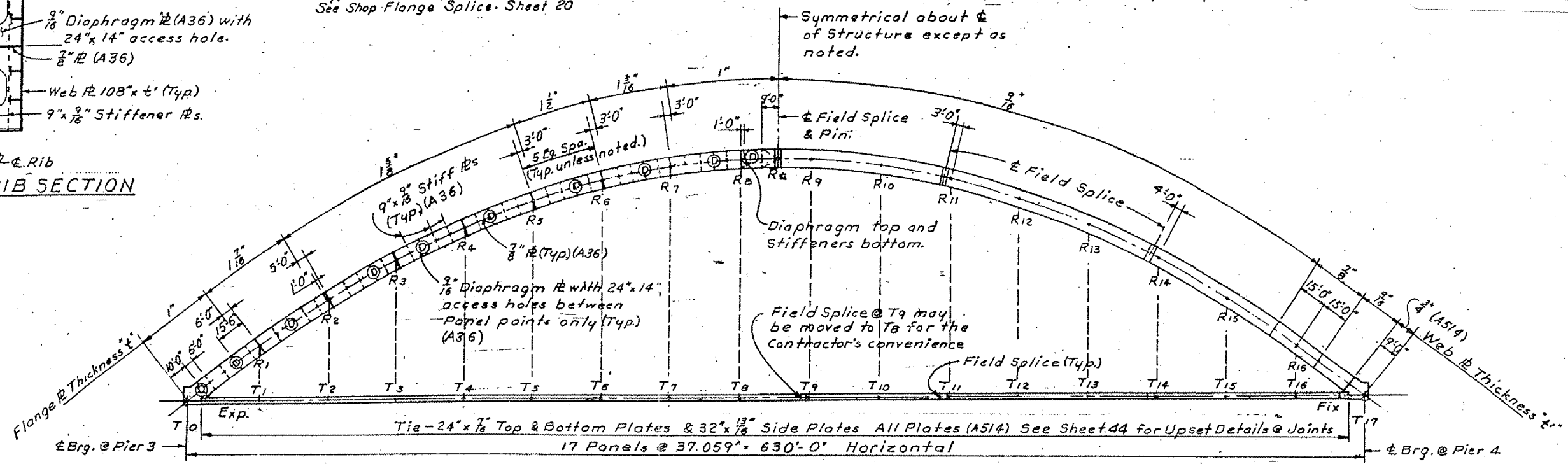

MEMBER FORCES

Member	Joint	Dead Load-Steel		Dead Load-Conc.		Future Wear Surf.		Live Load		Impact		Total (DL, FWS, LL, I)		10% (DL + FWS)		Design Total-10%	
		Axial Force	Bending Moment	Axial Force	Bending Moment	Axial Force	Bending Moment	Axial Force	Bending Moment	Axial Force	Bending Moment	Axial Force	Bending Moment	Axial Force	Bending Moment	Axial Force	Bending Moment
To-T17	To	+ 1,064	- 136	+ 1,715	- 178	+ 234	- 33	+ 469	- 78	+ 31	- 5	+ 3,513	- 430	+ 301	- 35	+ 3,212	- 395
To-T17	T17	+ 1,064	+ 136	+ 1,715	+ 178	+ 234	+ 33	+ 469	+ 78	+ 31	+ 5	+ 3,513	+ 430	+ 301	+ 35	+ 3,212	+ 395
To-R1	To	- 1,337	+ 136	- 2,155	+ 178	- 295	+ 33	- 371	- 1968	- 35	- 185	- 4,193	- 1806	- 379	+ 35	- 3,814	- 1,806
To-R1	R1	- 1,337	- 744	- 2,155	- 2,051	- 295	+ 137	- 189	+ 52,220	- 27	+ 7,520	- 4,003	+ 57,082	- 379	- 266	- 3,624	+ 57,082
R1-R2	R1	- 1,277	+ 744	- 2,050	+ 2,051	- 280	- 137	- 183	- 52,220	- 26	- 7,520	- 3,816	- 57,082	- 361	+ 266	- 3,455	- 57,082
R1-R2	R2	- 1,277	+ 2,396	- 2,050	+ 4,370	- 280	+ 187	- 204	+ 86,301	- 29	+ 12,427	- 3,840	+ 96,941	- 361	- 179	- 3,479	+ 96,941
R2-R3	R2	- 1,221	- 2,396	- 1,969	+ 4,370	- 269	- 187	- 163	- 86,301	- 24	- 12,427	- 3,646	- 96,941	- 346	+ 179	- 3,300	- 96,941
R2-R3	R3	- 1,221	+ 4,388	- 1,969	+ 3,058	- 269	+ 704	- 228	+ 104,658	- 30	+ 13,606	- 3,717	+ 120,298	- 346	+ 203	- 3,371	+ 120,095
R3-R4	R3	- 1,175	- 4,388	- 1,897	+ 3,058	- 259	- 704	- 192	- 104,658	- 25	- 13,606	- 3,548	- 120,298	- 333	- 203	- 3,215	- 120,095
R3-R4	R4	- 1,175	+ 3,342	- 1,897	- 7,552	- 259	+ 1,160	- 209	+ 109,671	- 27	+ 14,257	- 3,567	+ 126,878	- 333	+ 295	- 3,234	+ 126,583
R4-R5	R4	- 1,136	- 3,342	- 1,897	+ 7,552	- 251	- 1,160	- 181	- 109,671	- 24	- 14,257	- 3,429	- 126,878	- 322	- 295	- 3,107	- 126,583
R4-R5	R5	- 1,136	+ 1,763	- 1,837	+ 1,307	- 251	+ 1,779	- 240	+ 103,015	- 29	+ 12,259	- 3,493	+ 120,123	- 322	+ 485	- 3,171	+ 119,638
R5-R6	R5	- 1,105	- 1,763	- 1,779	- 1,307	- 243	- 1,779	- 218	- 103,015	- 26	- 12,259	- 3,371	- 120,123	- 313	- 485	- 3,058	- 119,638
R5-R6	R6	- 1,105	+ 3,599	- 1,779	+ 438	- 243	+ 1,806	- 229	+ 86,265	- 27	+ 10,266	- 3,383	+ 102,374	- 313	+ 584	- 3,070	+ 101,790
R6-R7	R6	- 1,082	- 3,599	- 1,750	+ 438	- 239	- 1,806	- 218	- 86,265	- 26	- 10,266	- 3,315	- 102,374	- 307	- 584	- 3,008	- 101,790
R6-R7	R7	- 1,082	+ 2,397	- 1,750	+ 3,886	- 239	+ 3,394	- 265	+ 66,942	- 32	+ 7,966	- 3,368	+ 79,451	- 307	+ 454	- 3,061	+ 78,997
R7-R8	R7	- 1,069	- 1,737	- 1,723	- 3,886	- 235	- 2,394	- 259	- 66,942	- 31	- 7,966	- 3,317	- 79,451	- 303	- 454	- 3,014	- 78,997
R7-R8	R8	- 1,069	+ 1,737	- 1,723	- 3,886	- 235	+ 2,394	- 259	+ 66,942	- 31	+ 7,966	- 3,317	+ 79,451	- 303	+ 454	- 3,014	+ 78,997
R7-R8	R8	- 1,069	- 888	- 1,723	+ 3,143	- 235	+ 2,345	- 225	+ 52,840	- 36	+ 8,507	- 3,288	+ 65,947	- 303	+ 460	- 2,985	+ 65,487
R8-R9	R8	- 1,064	+ 888	- 1,715	- 3,143	- 234	- 2,345	- 223	- 52,840	- 36	- 8,507	- 3,272	- 65,947	- 301	- 460	- 2,971	- 65,487
R8-R9	R9	- 1,064	0	- 1,715	0	- 234	+ 1,907	- 227	+ 46,600	- 37	+ 7,503	- 3,277	+ 56,010	- 301	+ 191	- 2,976	+ 55,819

NOTES
 All Dimensions are measured along chord.
 Sign Convention:
 Axial Load in kips: neg. = Compression pos. = Tension.
 Bending Moment in inch-kips.
 neg. Rotates Joint Counter Clockwise pos. Rotates Joint Clockwise.
 * 10% Reduction not used because it increases stress.
 ** Live Load + Impact and Future Wearing Surface are applied when joint is in a fixed condition. The Dead Load of the Concrete and Steel is applied when the joint is in a pinned condition.
 Rib forces are symmetrical about centerline of span for all practical purposes.

SHEET 39 OF 121

KENTUCKY DEPARTMENT OF HIGHWAYS
 ILLINOIS DEPARTMENT OF PUBLIC WORKS AND BUILDINGS
 PROJECTS 124-11(6)138, 124-9(1)10, 124-11(6)11
 BRIDGE OVER OHIO RIVER ON 124 BETWEEN MACCRACKEN COUNTY, KENTUCKY AND MASSACON COUNTY, ILLINOIS

HAZLET & BRIDAL Consulting Engineers
 BRIDGE NUMBER 17471
 DRAWING NO. 17471
 INDEX

RIB STRESS UNIT II

CONTRACT: 98990
 ROUTE: INTERSTATE 24
 SECTION: (64-3B)1-6
 COUNTY: MASSAC, IL; McCracken, KY
 SHEET 32 OF 99
 FOR INFORMATION ONLY

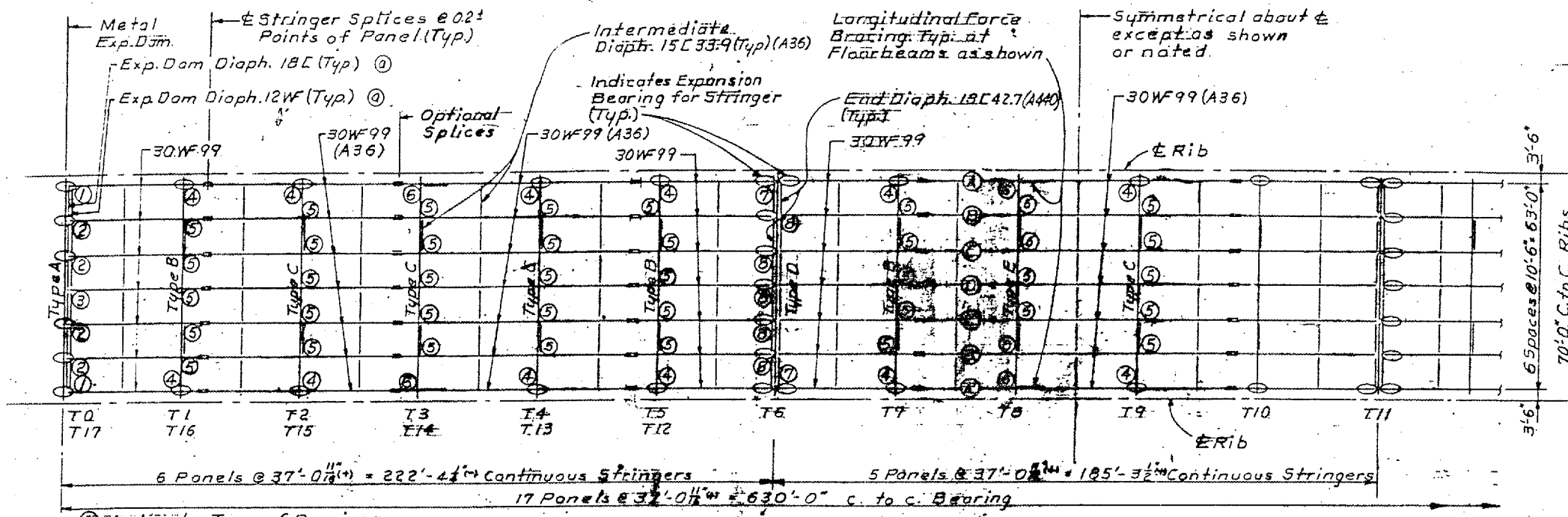

FLOOR SYSTEM FRAMING PLAN

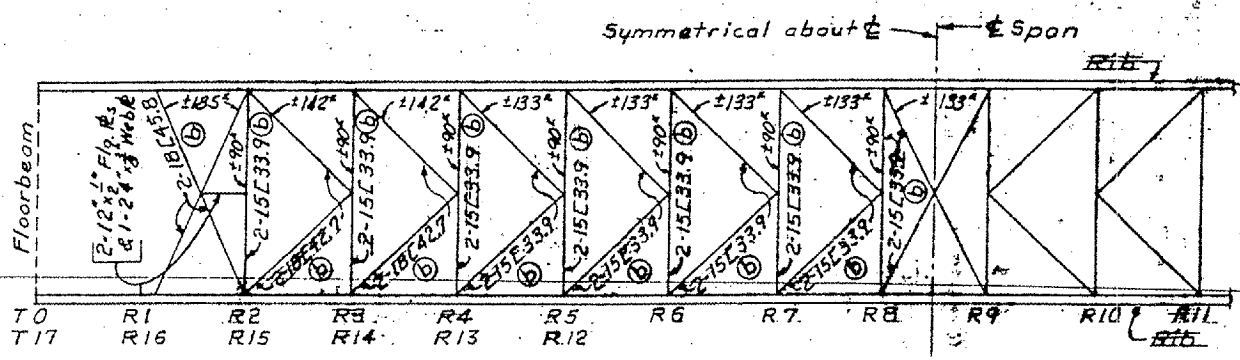

PLAN OF TOP LATERAL BRACING

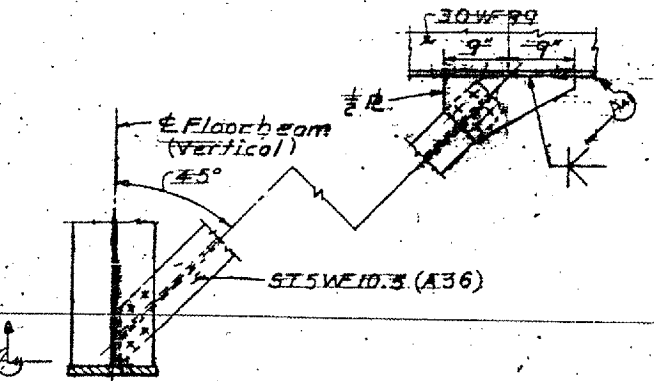

LONGITUDINAL FORCE BRACING AT STRINGERS A AND A'

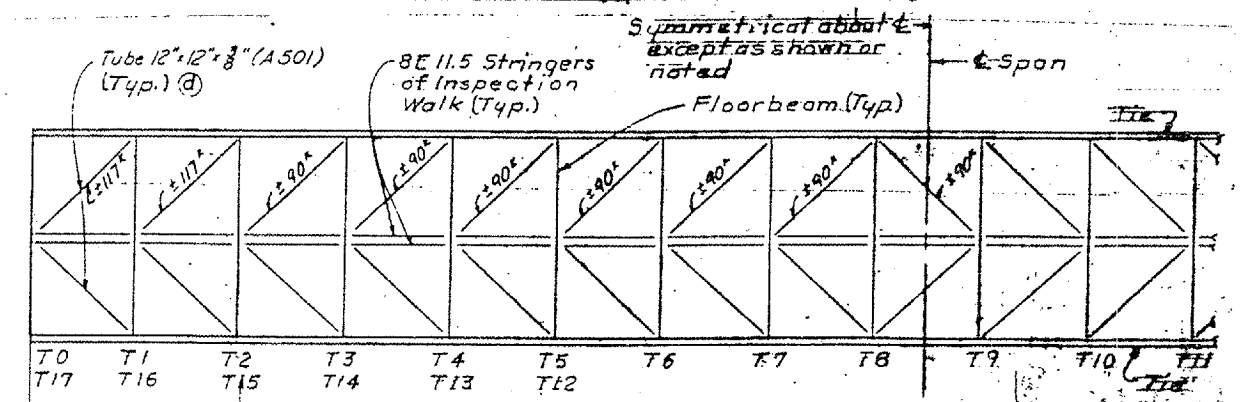

PLAN OF BOTTOM LATERAL BRACING

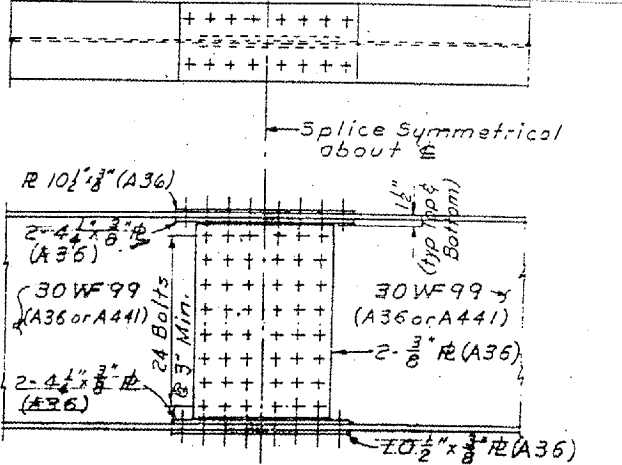

FIELD SPLICE FOR 30WF99 STRINGER

- NOTE:
- ① See Expansion Dam Detail, Sheet 44 for Details.
 - ② See Sheet 46 for details of Stiffeners and Web Plates.
 - ③ All bracing shall be A36 steel and shall be detailed to the deformed length of the tie or rib.
 - ④ Camber the Tubes 12" x 12" up 1/8" For 30W Stringers turn any natural camber up.
 - For Diaphragm Details see Sheet 56

UNIT II STRUCTURAL STEEL QUANTITIES (LBS)									
Part of Project	Drains	Cables	Strand	A36	A440	A441	Shoes	Exp. Dam	
121.911	0	0	0	109,268	156,303	10,700	1,064,912	49,914	64,986
							770,868		

FRAMING PLAN FOR UNIT II STRUCTURAL STEEL

KENTUCKY DEPARTMENT OF HIGHWAYS
 ILLINOIS DEPARTMENT OF PUBLIC WORKS AND BUILDINGS
 PROJECTS 124-1(6)356, 124-9(1)10, 124-1(6)11
 BRIDGE OVER OHIO RIVER CH 134
 BETWEEN McCracken COUNTY, KENTUCKY AND MASSAC COUNTY, ILLINOIS

HAZLET & BIDAL Consulting Engineers
 BRIDGE NUMBER 17471
 DRAWING NO. 17471

DESIGNED BY: M.D.C. 9-67
 CHECKED BY: CHH
 DATE: 10/1/68
 SCALE: AS SHOWN
 SHEET 32 OF 99



CONTRACT: 98990
 ROUTE: INTERSTATE 24
 SECTION: (64-3B) I-6
 COUNTY: MASSAC, IL; McCracken, KY
 SHEET 33 OF 99
 FOR INFORMATION ONLY

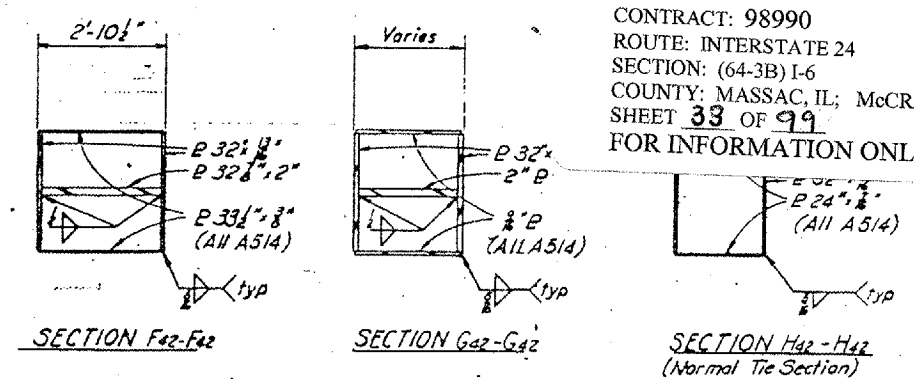
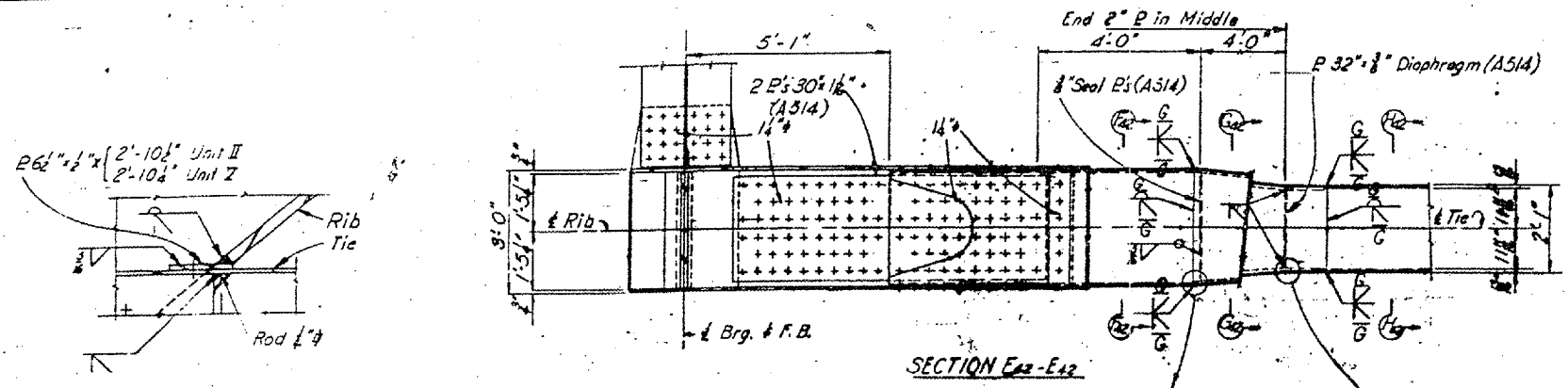

DETAIL D42
 (In Section)

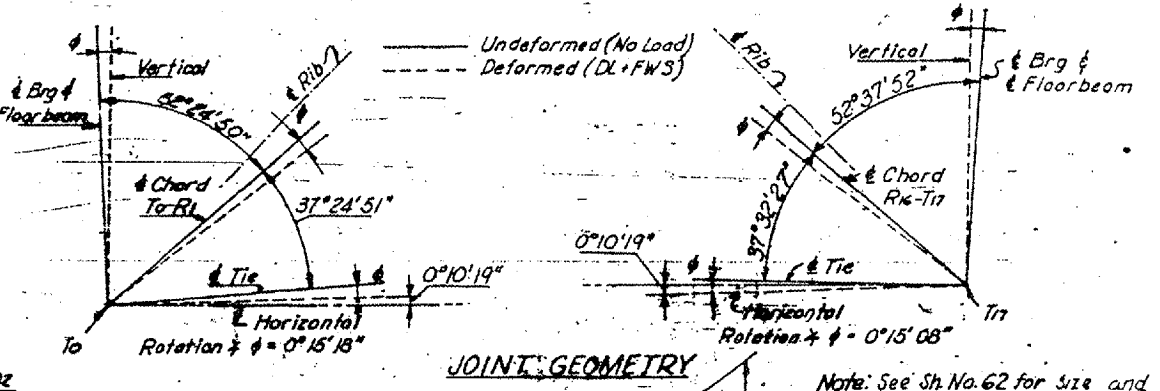
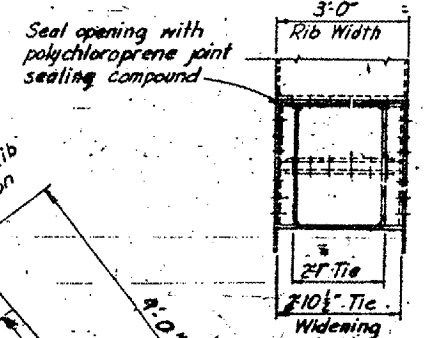
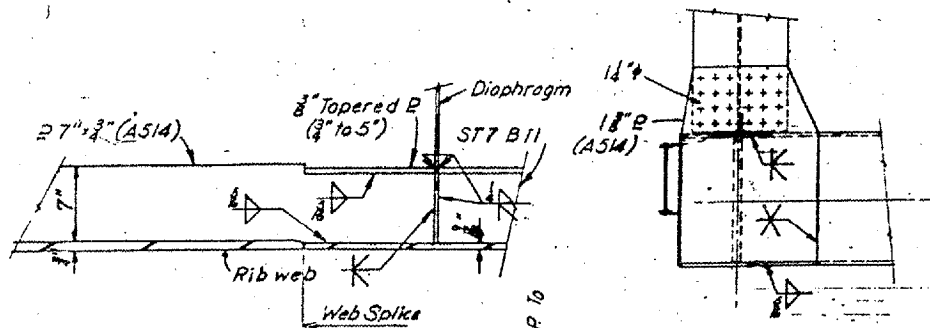

Note: See Sh. No. 62 for size and type of rail and post plus other details not shown.

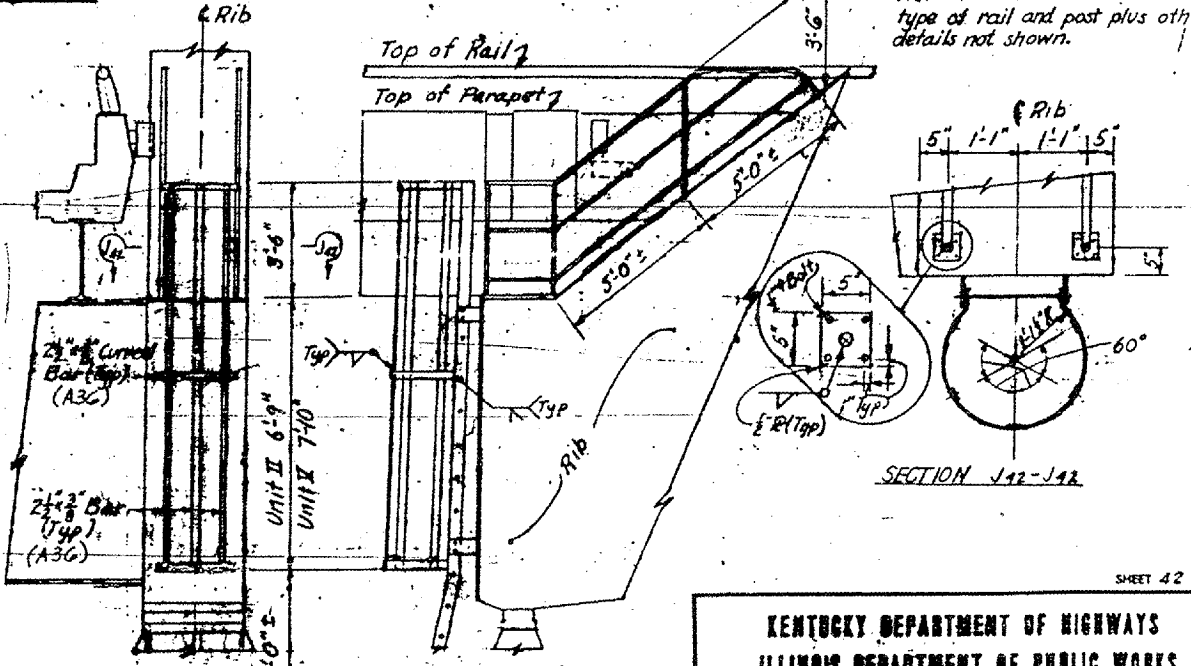
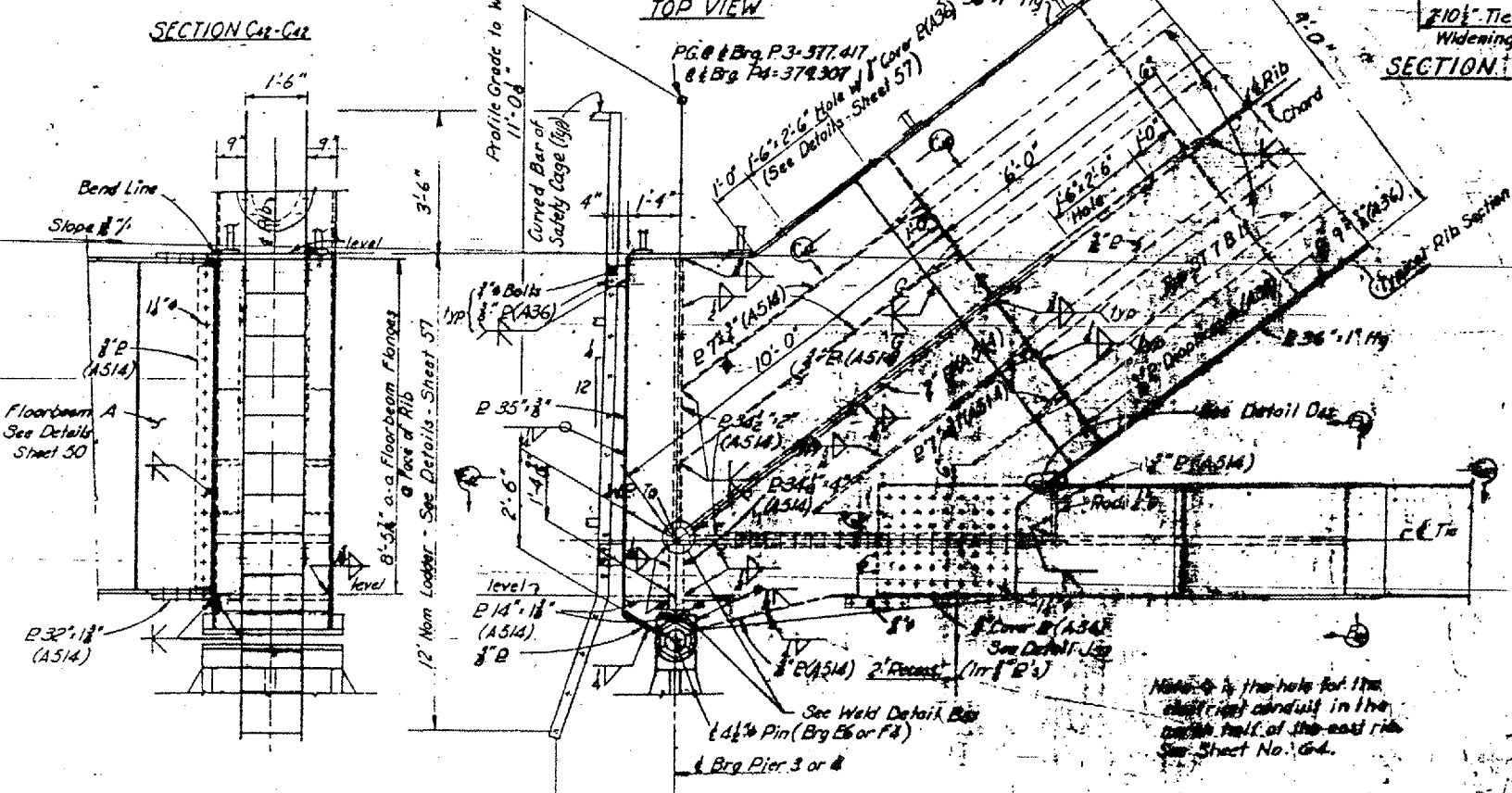

DESIGNED BY: RBS
 DRAWN BY: RBS
 CHECKED BY: RBS
 DATE: 11/11/68
 PROJECT: INTERSTATE 24
 SHEET: 33 OF 99

SHEET 42 OF 99

KENTUCKY DEPARTMENT OF HIGHWAYS
 ILLINOIS DEPARTMENT OF PUBLIC WORKS
 AND BUILDINGS

PROJECTS 124-1(6) 308, 124-9(1) 10, 124-1(6) 1
 BRIDGE OVER OHIO RIVER ON I-24
 BETWEEN MACCRACKEN COUNTY, KENTUCKY
 AND MASSAC COUNTY, ILLINOIS

HAZLET & FRANK Consulting Engineers P.O. No. 288	BRIDGE NUMBER	DRAWING NO. 17471	INDEX
--	------------------	----------------------	-------

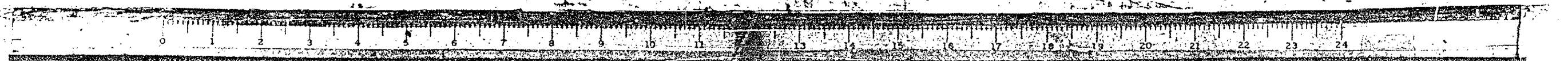

CONTRACT: 98990
 ROUTE: INTERSTATE 24
 SECTION: (64-3B) I-6
 COUNTY: MASSAC, IL; McCRACKEN, KY
 SHEET 34 OF 99
 FOR INFORMATION ONLY

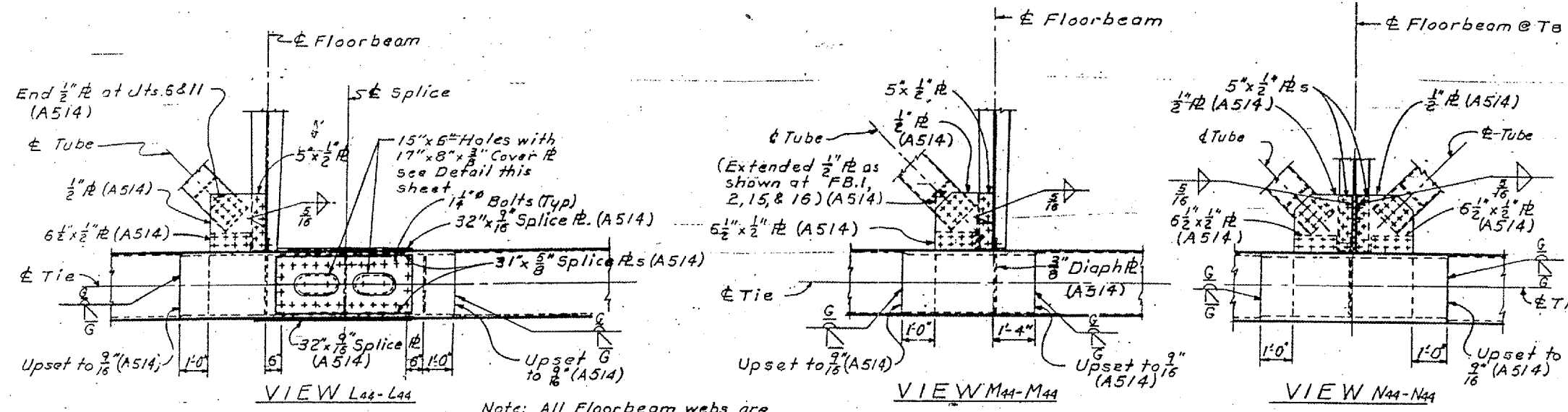

Note: All Floorbeam webs are vertical. The Tie is parallel to the Profile Grade (0.3%)

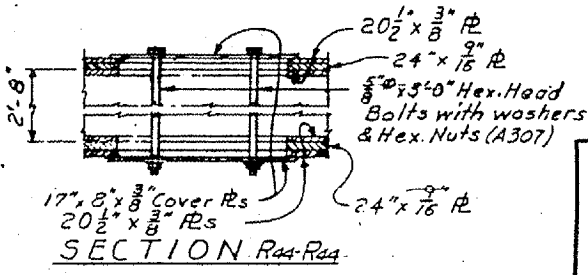
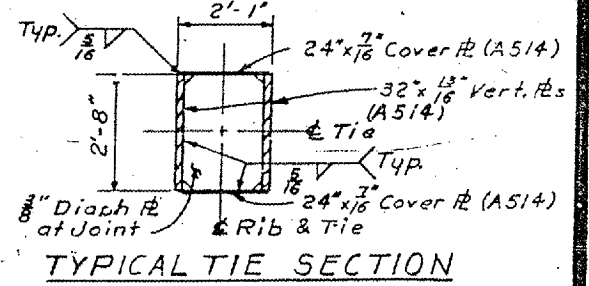
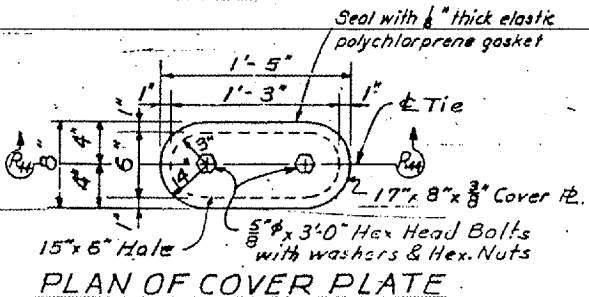
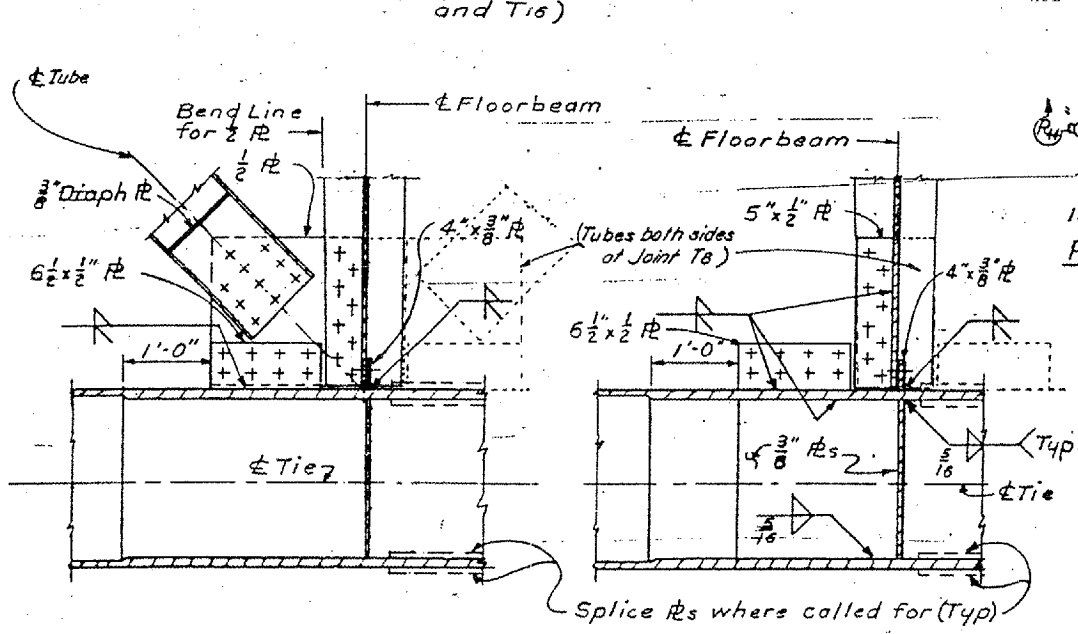
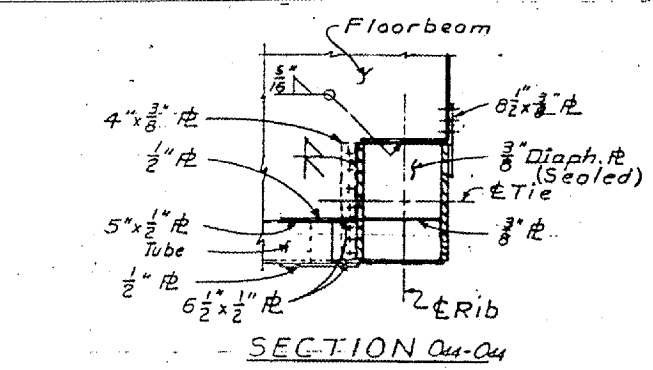
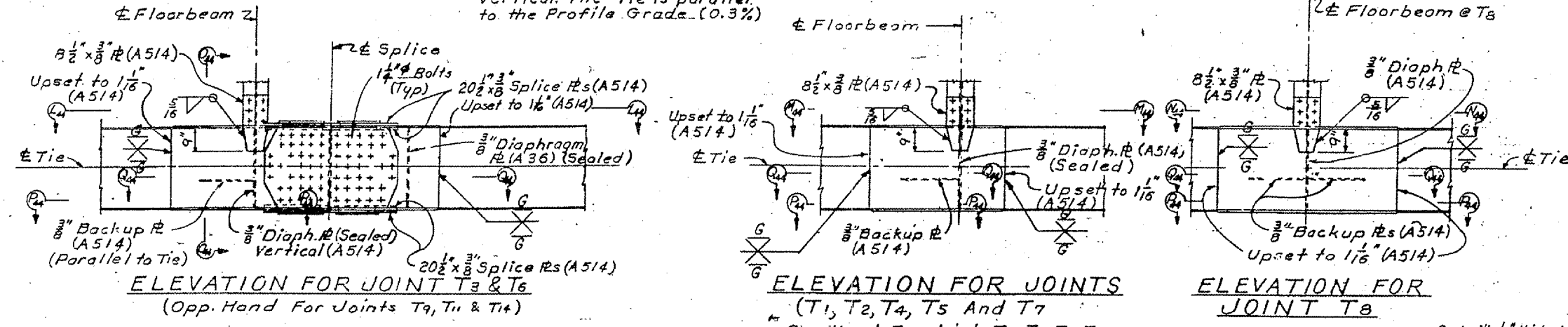
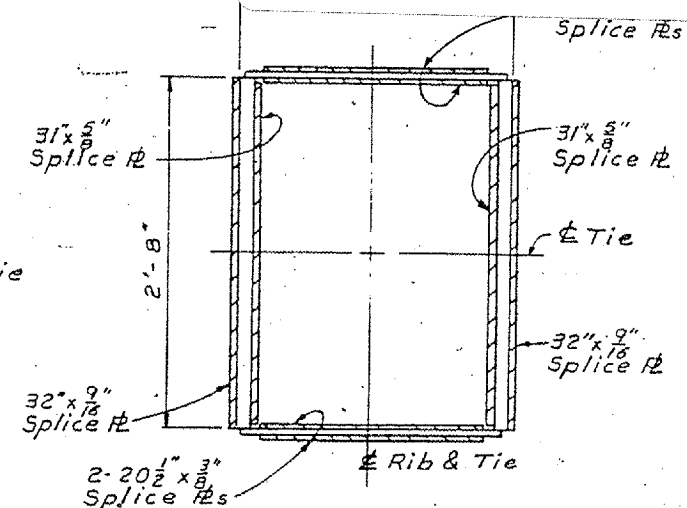

TIE SPLICE DETAILS FOR UNIT II
 STRUCTURAL STEEL

DESIGNED BY: J.B.
 CHECKED BY: M.D.C.
 DRAWN BY: R.B.S.
 SCALE: AS SHOWN
 DATE: 1-2-55

SHEET 44 OF 99

KENTUCKY DEPARTMENT OF HIGHWAYS
 ILLINOIS DEPARTMENT OF PUBLIC WORKS AND BUILDINGS
 PROJECTS 124-11(6) 358, 124-9(1) 10, 124-11(6) 11
 BRIDGE OVER OHIO RIVER ON I-24
 BETWEEN MACCRACKEN COUNTY, KENTUCKY
 AND MASSAC COUNTY, ILLINOIS

HAZLET & BIDAL Consulting Engineers
 P.O. No. 288
 BRIDGE NUMBER
 DRAWING NO. 17471
 INDEX

CONTRACT: 98990
 ROUTE: INTERSTATE 24
 SECTION: (64-3B) I-6
 COUNTY: MASSAC, IL; McCRACKEN, KY
 SHEET 35 OF 99
 FOR INFORMATION ONLY

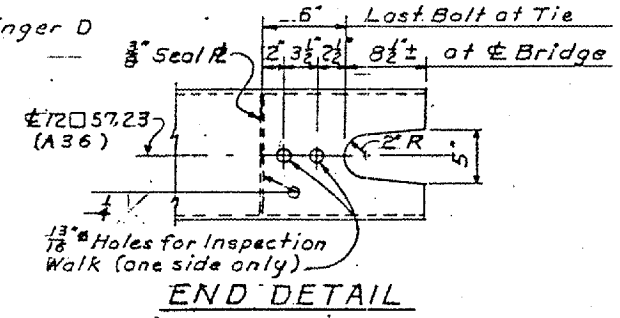
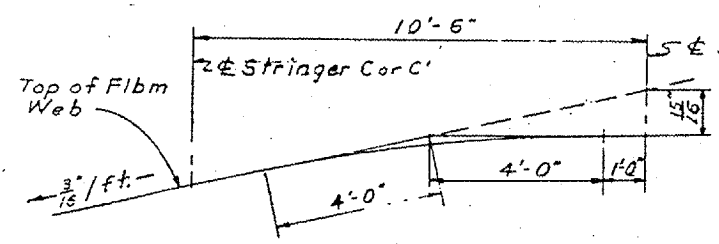
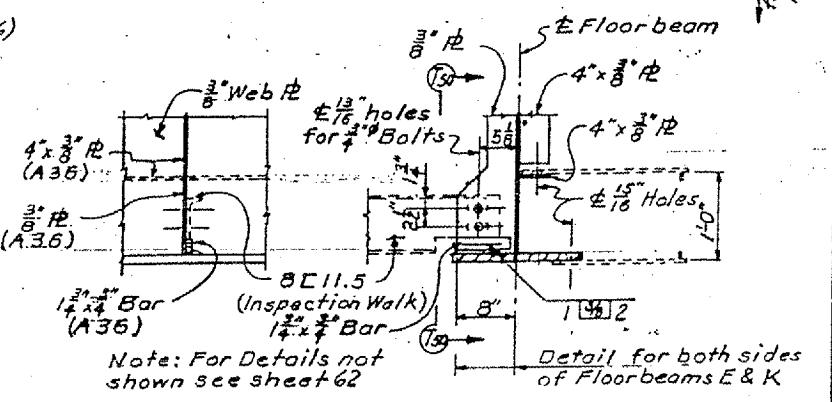
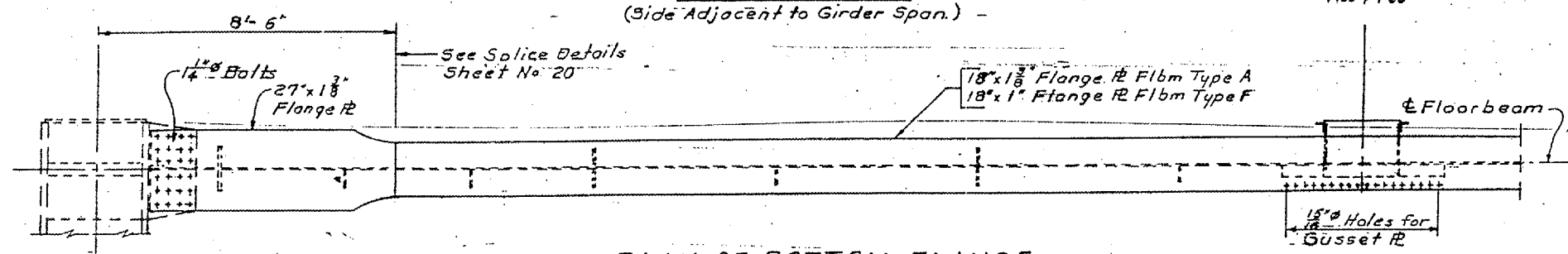
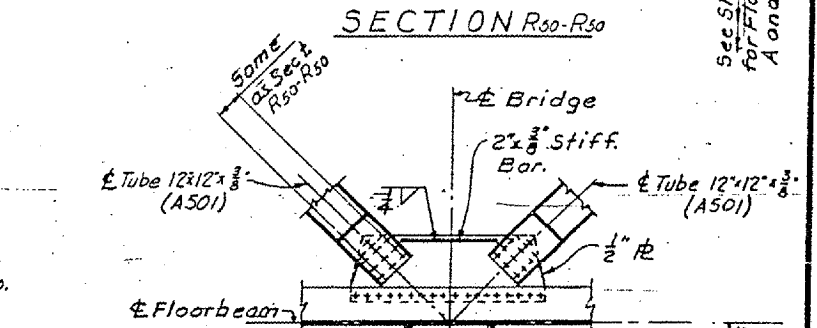
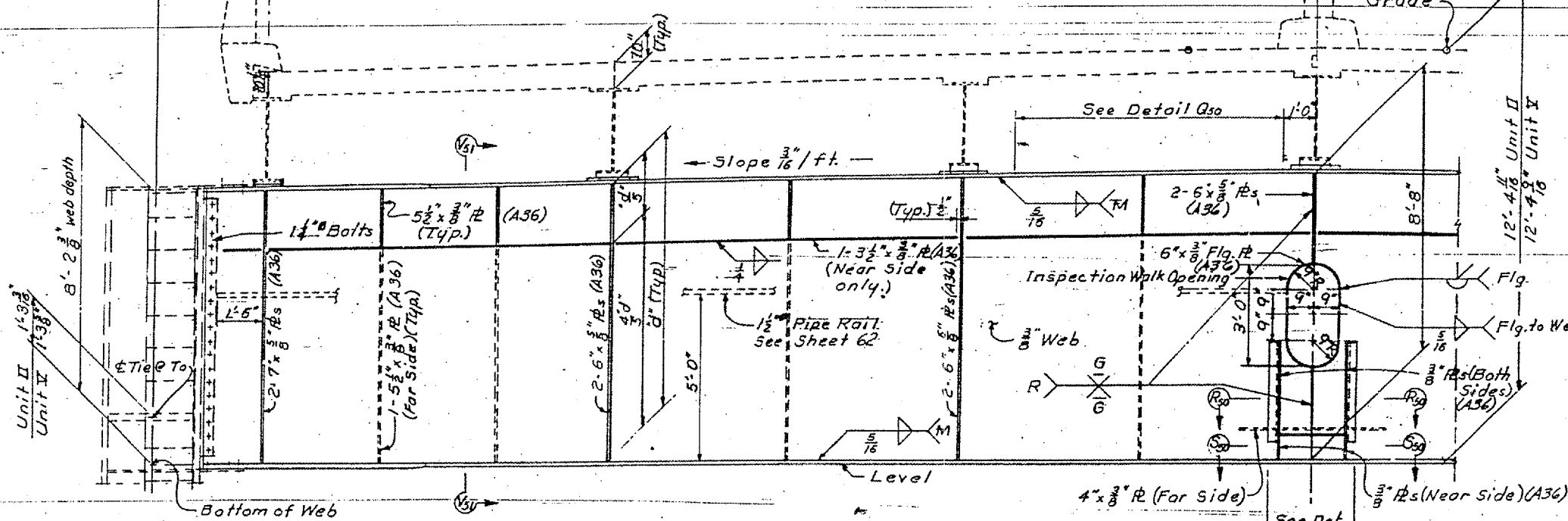
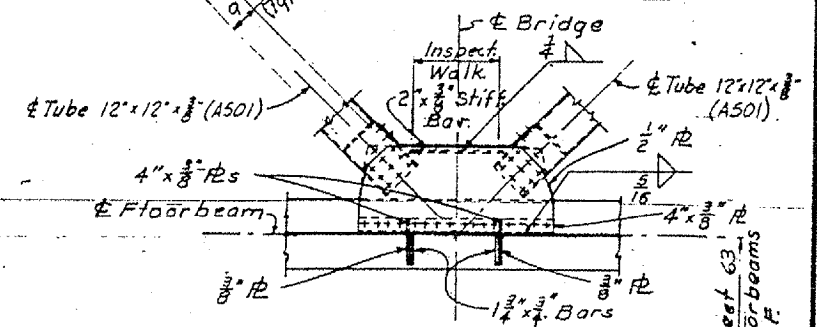
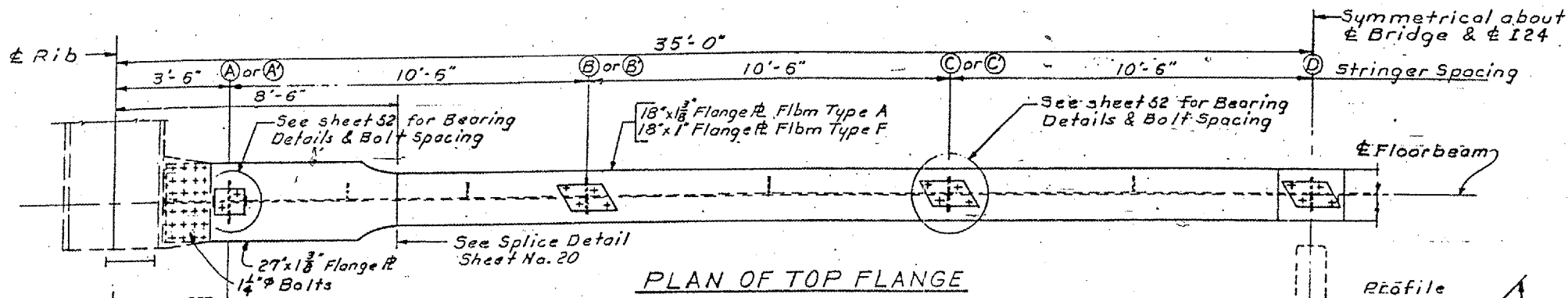

UNITS II & IV
 FLOORBEAM A & F DETAILS
 STRUCTURAL STEEL

KENTUCKY DEPARTMENT OF HIGHWAYS
 ILLINOIS DEPARTMENT OF PUBLIC WORKS
 AND BUILDINGS

PROJECTS 124-1(6) 135, 124-9(1) 10, 124-1(1) 11
 BRIDGE OVER OHIO RIVER ON I24
 BETWEEN McCRACKEN COUNTY, KENTUCKY
 AND MASSAC COUNTY, ILLINOIS

HAZLET & BEND
 Consulting Engineers
 P.O. No. 888

BRIDGE NUMBER
 17471

DRAWING NO.
 INDEX

DESIGNED BY: JDB
 CHECKED BY: MDC
 DATE: 11-6-60
 DRAWN BY: RAS
 DATE: 11-6-60
 CHECKED BY: RAS
 DATE: 11-6-60

Note: For Longitudinal Force Bracing Connection See Framing Plans.

Symmetrical about Bridge & I24

Stringer Spacing

CONTRACT: 98990
 ROUTE: INTERSTATE 24
 SECTION: (64-3B) 1-6
 COUNTY: MASSAC, IL; McCRACKEN, KY
 SHEET 36 OF 99
 FOR INFORMATION ONLY

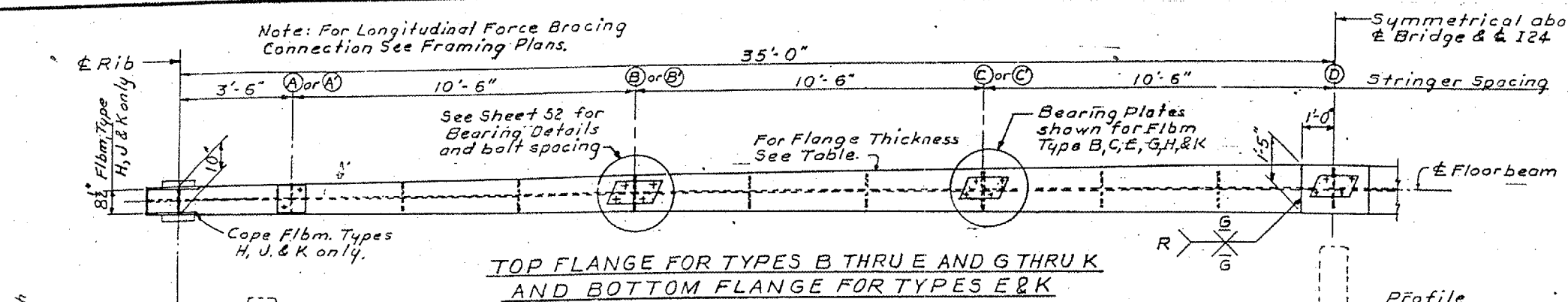

TOP FLANGE FOR TYPES B THRU E AND G THRU K
 AND BOTTOM FLANGE FOR TYPES E & K

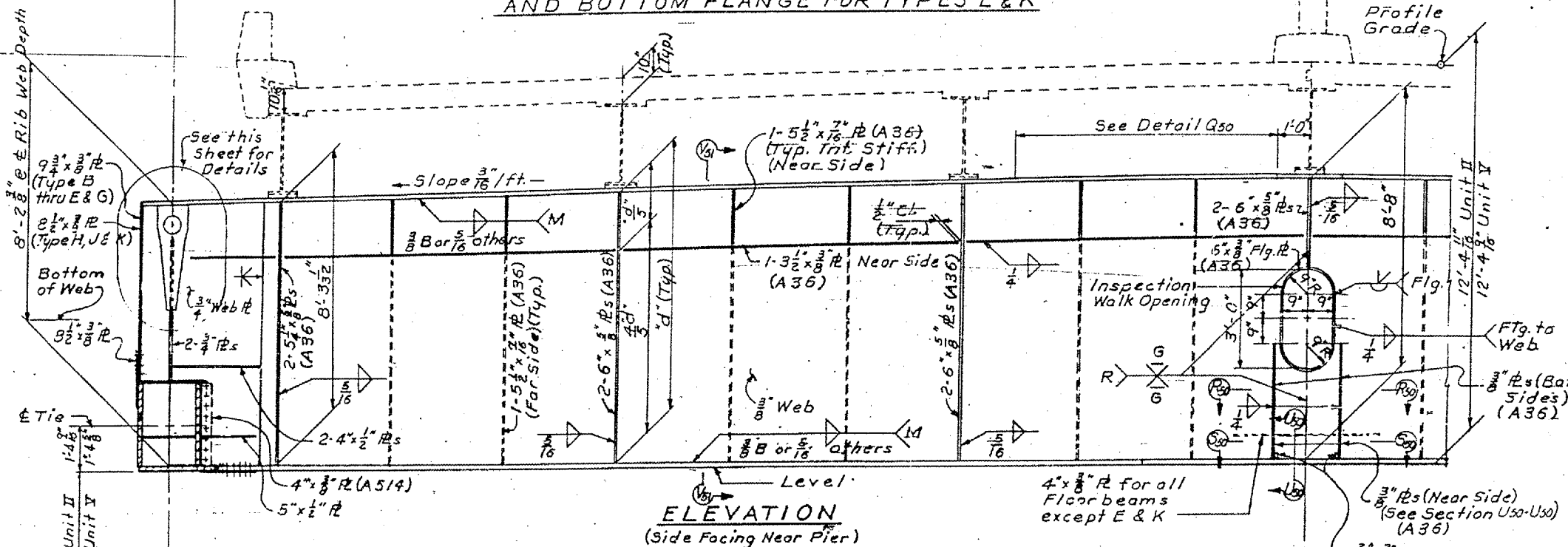

ELEVATION
 (Side Facing Near Pier)

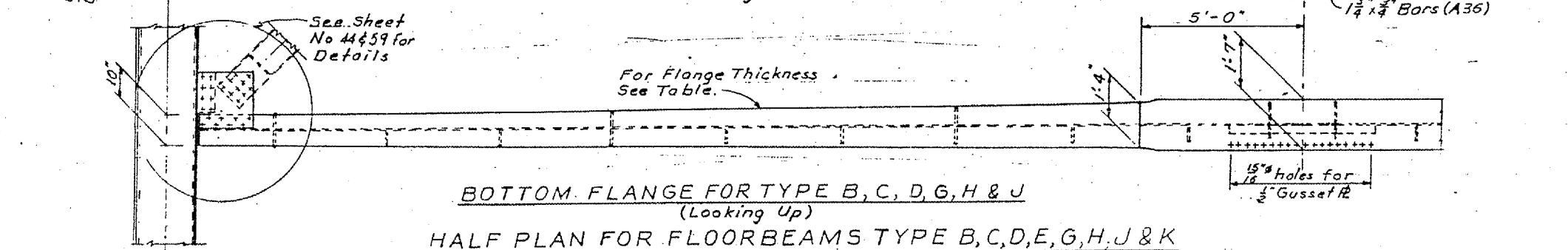

BOTTOM FLANGE FOR TYPE B, C, D, G, H & J
 (Looking Up)
 HALF PLAN FOR FLOORBEAMS TYPE B, C, D, E, G, H, J & K

FLANGE PLATE THICKNESS							
FLOORBEAM TYPE	B	C	D	E	G	H	K
THICKNESS	1 9/16	1 7/16	1 5/16	1 1/2	1 1/2	1 1/8	1 1/8

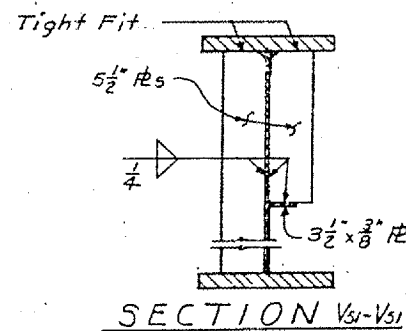

SECTION V51-V51

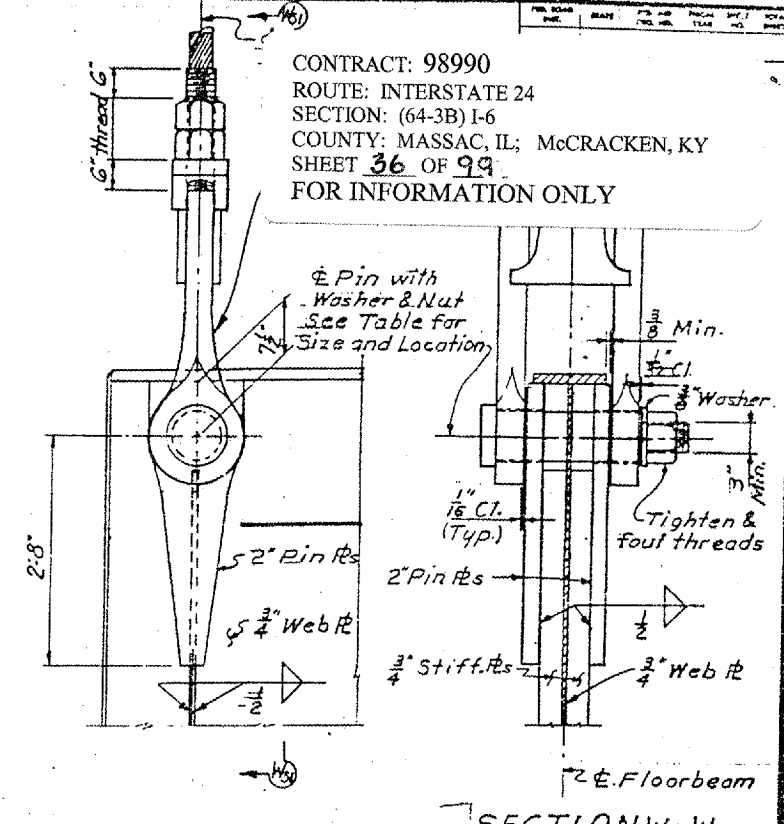

SECTION W51-W51

BRIDGE STRAND AND PIN SIZE TABLE					
STRAND SIZE	MINIMUM BREAKING STR. TONS	PIN SIZE ①		UNIT II PANEL POINTS	UNIT V PANEL POINTS
		MIN.	MAX.		
3" φ	538	6" φ	6 3/4" φ		T2, 4, 5, 9, 11, 13, 15, 17, 19
3 1/2" φ	584	6" φ	7" φ		T2, 3, 4, 6, 8, 7, 11, 13, 14, 15
3 3/4" φ	625	6 1/2" φ	7" φ		T1, 5, 7, 10, 12, 16

- ① Pin shall be A237 Class B Steel. Diameter of Pin hole shall be 1/32" (Max.) larger than the Pin Diameter. The outside Diameter of 3/8" Washer shall be 1" greater than the Pin Diameter.
- ② Forged Eye-rods size and Class shall be selected to be compatible with size and strength of strand and socket furnished.

HANGER ASSEMBLY

UNITS II & V
 INTERIOR FLOORBEAM DETAILS
 STRUCTURAL STEEL

KENTUCKY DEPARTMENT OF HIGHWAYS
 ILLINOIS DEPARTMENT OF PUBLIC WORKS
 AND BUILDINGS

PROJECTS 124-11(1) 138, 124-9(1) 10, 124-11(1) 611
 BRIDGE OVER OHIO RIVER ON I24
 BETWEEN McCRACKEN COUNTY, KENTUCKY
 AND MASSAC COUNTY, ILLINOIS

HAZLET & BRAD
 Consulting Engineers
 P.E. No. 588

8:1000
 NUMBER

DRAWING NO.
 17471

CONTRACT: 98990
 ROUTE: INTERSTATE 24
 SECTION: (64-3B) I-6
 COUNTY: MASSAC, IL; McCRACKEN, KY
 SHEET 37 OF 99
 FOR INFORMATION ONLY

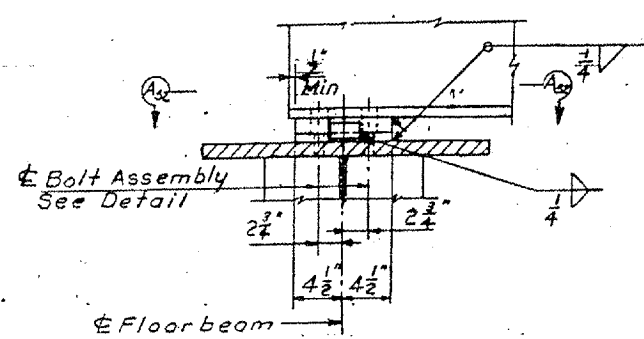

TYPE ①

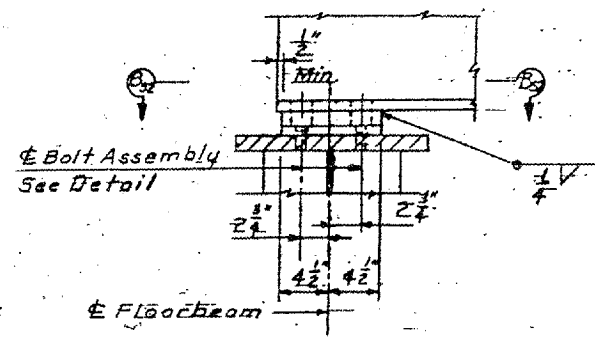

TYPE ② or ③

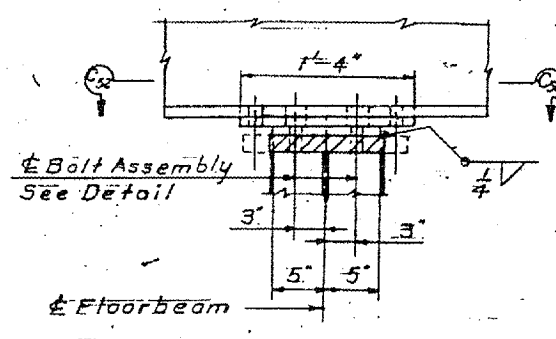

TYPE ④ or ⑤

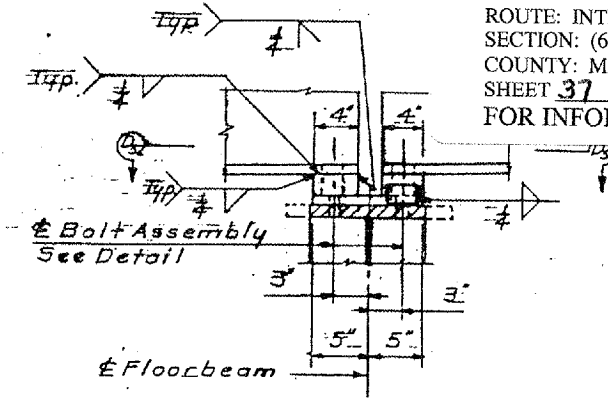

TYPE ⑦

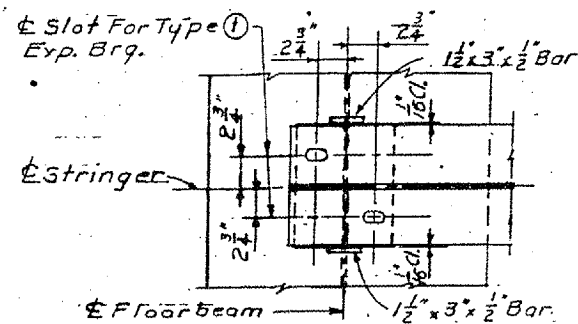

SECTION A52-A52

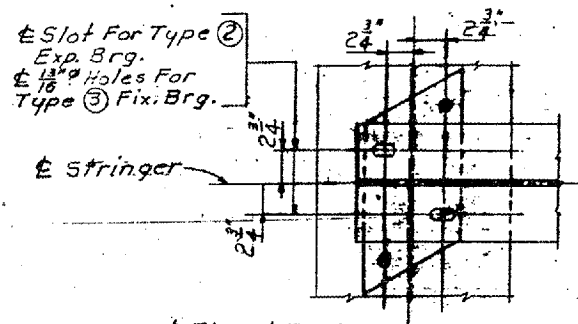

SECTION B52-B52

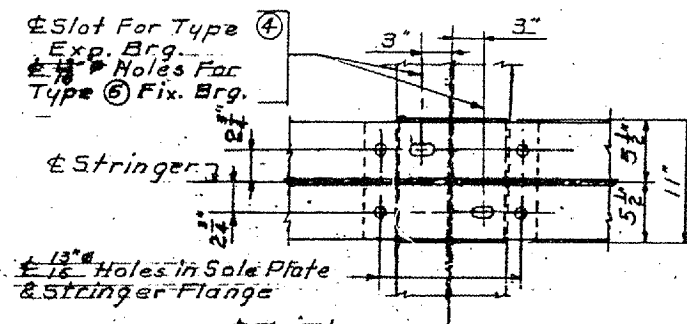

SECTION C52-C52

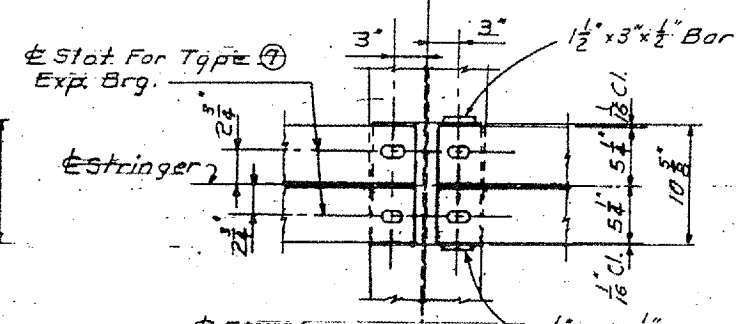

SECTION D52-D52

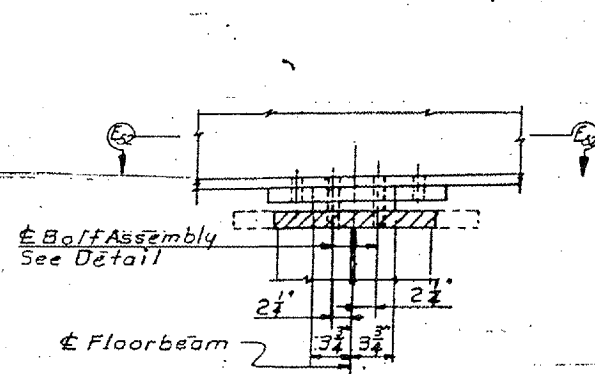

TYPE ⑤

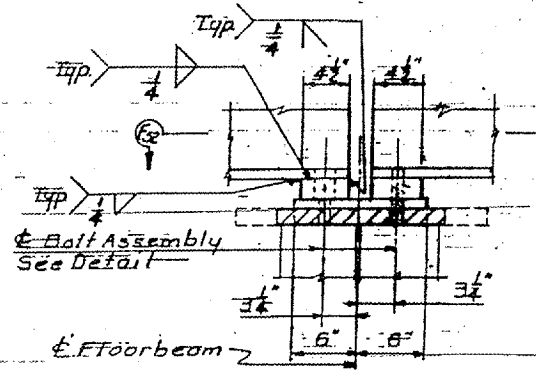

TYPE ⑧

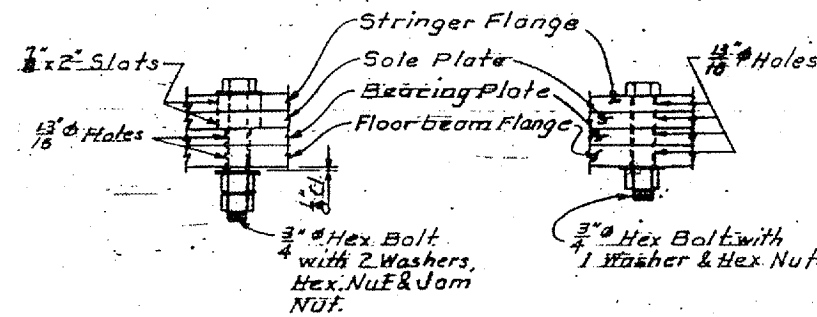

EXPANSION BEARING FIXED BEARING BOLT ASSEMBLY DETAILS

TABLE OF SOLE PLATES THICKNESS "t"

FLOORBEAM TYPE	STRINGERS		
	A or A'	B, C, C' or B'	D
A, H or K	1 1/8"	1 1/8"	2 1/8"
B or G	1"	1"	1 15/16"
C or E	1 1/4"	1 1/4"	2 3/8"
D	1 3/8"	1 3/8"	2 1/8"
F	1 1/8"	2"	2 1/8"
J	2"	2"	2 1/8"

NOTE:
 All Bolts are 3/4" of this sheet
 All Sole Plates and Bearing Plates to be A36 steel.

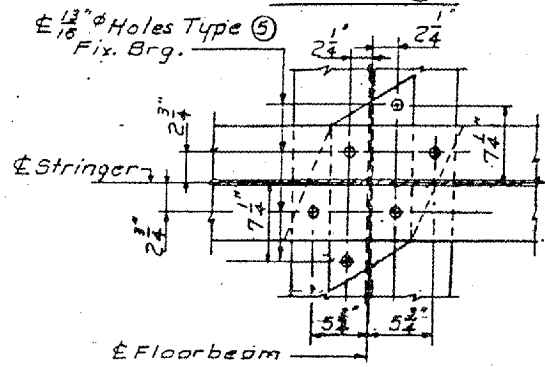

SECTION E52-E52

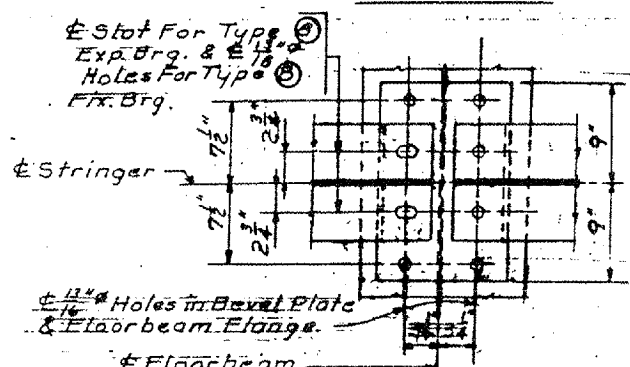

SECTION F52-F52

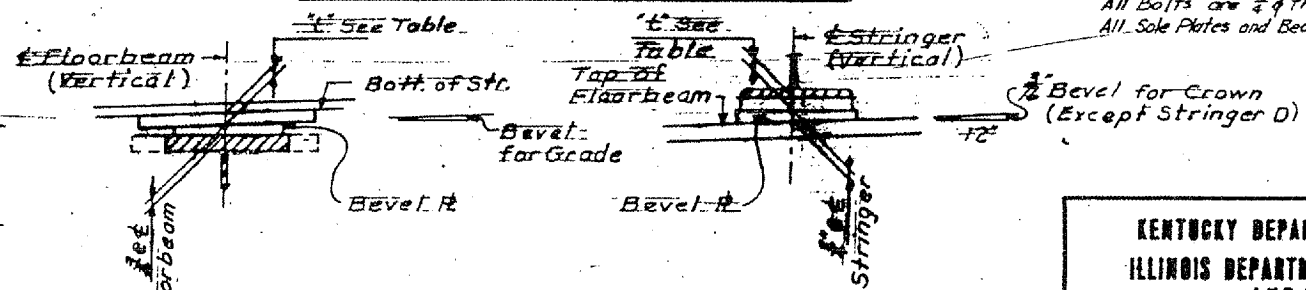

STRINGER TO FLOORBEAM CONNECTION DETAILS BEARING DETAILS FOR STRINGERS STRUCTURAL STEEL

KENTUCKY DEPARTMENT OF HIGHWAYS
 ILLINOIS DEPARTMENT OF PUBLIC WORKS AND BUILDINGS
 PROJECTS: I 24-11(6) 358, I 24-91(1) 10, I 24-11(6) 11
 BRIDGE OVER OHIO RIVER ON I 24
 BETWEEN McCRACKEN COUNTY, KENTUCKY AND MASSAC COUNTY, ILLINOIS

HAZLET & BIDAL Consulting Engineers, Inc. No. 265
 BRIDGE NUMBER
 DRAWING NO. 117471
 INDEX

SHEET 52 OF 121

CONTRACT: 98990
 ROUTE: INTERSTATE 24
 SECTION: (64-3B)1-6
 COUNTY: MASSAC, IL; McCRACKEN, KY
 SHEET 38 OF 99
 FOR INFORMATION ONLY

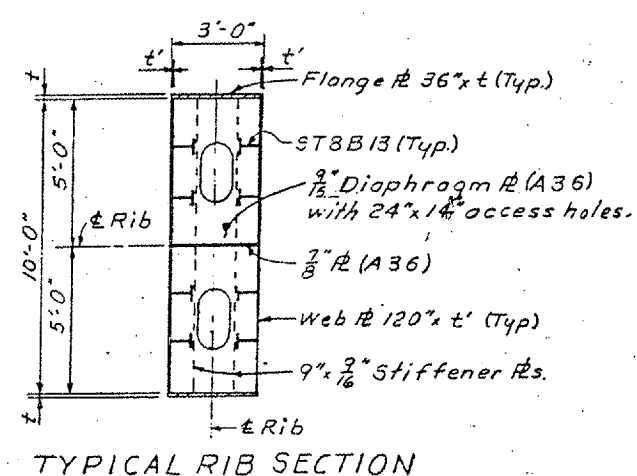

Half Rib Elevation Showing Flange Thickness and Length Plus Diaphragm and Stiffener Location. (Typical each Half.) See Shop Flange Splice, Sheet 20.

Half Rib Elevation Showing Web Plate Thickness and Field Splice Location (Typical Each Half Except for Field Splice @ T10) See Shop Web Splice, Sheet 20

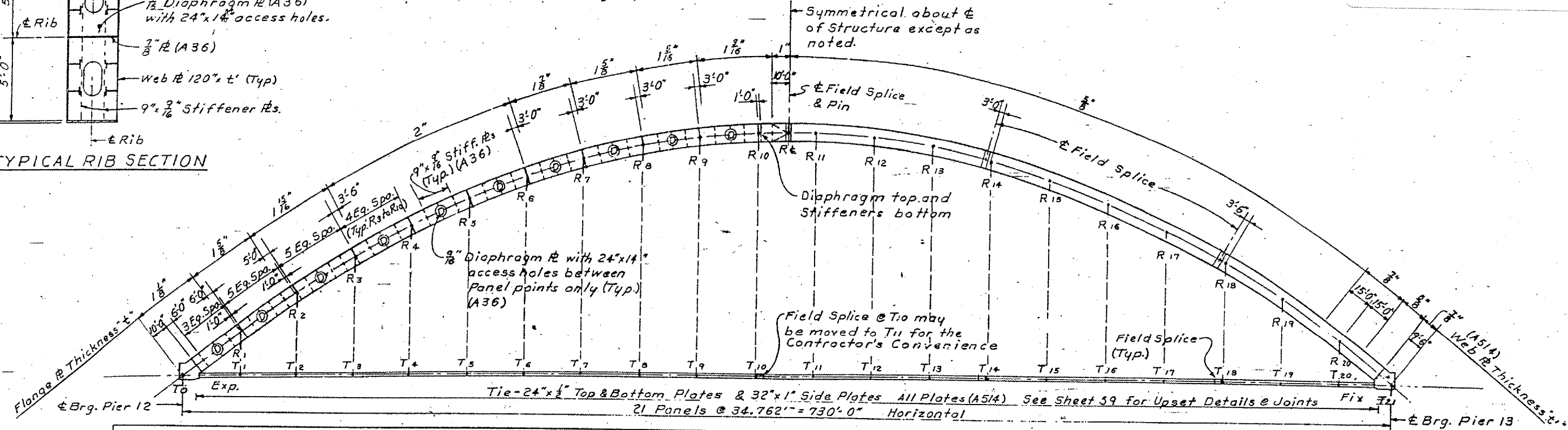

MEMBER FORCES

Member	Joint	Dead Load-Steel		Dead Load-Conc.		Future Wear Surf.		Live Load		Impact		Total (DL, FWS, LL & I)		10% (DL + FWS)		Design Total - 10%	
		Axial Force	Bending Moment	Axial Force	Bending Moment	Axial Force	Bending Moment	Axial Force	Bending Moment	Axial Force	Bending Moment	Axial Force	Bending Moment	Axial Force	Bending Moment	Axial Force	Bending Moment
To-T2L	To	+1370	-172	+2009	-152	+272	-29	+539	-59	+32	-3	+4222	-415	+365	-35	+3857	-380
To-T21	T21	+1370	+172	+2009	+152	+272	+29	+539	+59	+32	+3	+4222	+415	+365	+35	+3857	+380
To-R1	To	-1737	+172	-2537	+152	-343	+29	-388	+2266	-41	+240	-5046	+2859	-462	+35	-4584	+2824
To-R1	R1	-1737	+1998	-2537	-4663	-343	-72	-252	+57042	-34	+7758	-4903	+62063	-462	-274*	-4441	+62063
R1-R2	R1	-1672	-1998	-2434	+4663	-330	+72	-202	-57042	-27	-7758	-4665	-62063	-444	+274*	-4221	-62063
R1-R2	R2	-1672	+7928	-2434	-9226	-330	-203	-223	+97985	-30	+13326	-4689	+109810	-444	-150*	-4245	+109810
R2-R3	R2	-1610	-7928	-2357	+9226	-320	+203	-182	-97985	-25	-13326	-4494	-109810	-429	+150*	-4065	-109810
R2-R3	R3	-1610	+11347	-2357	-8706	-320	+309	-245	+126371	-30	+15670	-4562	+144991	-429	+295	-4133	+144696
R3-R4	R3	-1551	-11347	-2270	+8706	-307	+309	-201	-126371	-25	-15670	-4354	-144991	-413	-295	-3941	-144696
R3-R4	R4	-1551	+12523	-2270	-10864	-307	+378	-221	+139435	-27	+17290	-4376	+158762	-413	+204	-3963	+158558
R4-R5	R4	-1504	-12523	-2217	+10864	-300	-378	-193	-139435	-24	-17290	-4238	-158762	-402	-204	-3836	-158558
R4-R5	R5	-1504	+8602	-2217	-6149	-300	+1363	-252	+144051	-29	+16422	-4302	+164289	-402	+382	-3900	+163907
R5-R6	R5	-1463	-8602	-2149	+6149	-291	-1363	-223	-144051	-25	-16422	-4151	-164289	-390	-382	-3761	-163907
R5-R6	R6	-1463	+6806	-2149	-5108	-291	+1771	-236	+136748	-27	+15589	-4166	+155806	-390	+347	-3776	+155459
R6-R7	R6	-1430	-6806	-2102	+5108	-284	-1771	-216	-136748	-26	-15589	-4058	-155806	-382	-347	-3676	-155459
R6-R7	R7	-1430	+4274	-2102	-2194	-284	+2387	-270	+122735	-27	+13010	-4113	+140212	-382	+447	-3731	+139765
R7-R8	R7	-1402	-4274	-2058	+2194	-278	-2387	-254	-122735	-27	-13010	-4019	-140212	-374	-447	-3645	-139765
R7-R8	R8	-1402	+2711	-2058	-1957	-278	+2561	-303	+100850	-30	+9934	-4071	+114099	-374	+332	-3697	+113767
R8-R9	R8	-1384	-2711	-2035	+1957	-275	-2561	-294	-100850	-29	-9934	-4017	-114099	-369	-332	-3648	-113767
R8-R9	R9	-1384	+1478	-2035	+3021	-275	+3357	-320	+79398	-36	+9051	-4050	+93349	-369	+490	-3681	+92859
R9-R10	R9	-1374	-1478	-2015	-3021	-272	-3357	-313	-79398	-36	-9051	-4010	-93349	-366	-490	-3664	-92859
R9-R10	R10	-1374	+338	-2015	+3617	-272	+3495	-285	+67133	-39	+9130	-3985	+83037	-366	+677	-3619	+82360
R10-R11	R10	-1370	-338	-2009	-3617	-272	-3495	-284	-67133	-39	-9130	-3974	-83037	-365	-677	-3609	-82360
R10-R11	R11	-1370	0	-2009	0	-272	+3006	-286	+61047	-39	+8350	-3976	+72403	-365	+301	-3611	+72102

NOTE
 All Dimensions are measured along chord.
 Sign Convention:
 Axial Load in kips: neg. = Compression pos. = Tension
 Bending Moment in inch kip
 neg. = Rotates Joint Counter Clockwise.
 pos. = Rotates Joint Clockwise
 * 10% Reduction not used because it increases stress.
 ** Live Load + Impact and Future Wearing Surface are applied when joint is in a fixed condition. The Dead Load of the Concrete and Steel is applied when the joint is in a pinned condition.

KENTUCKY DEPARTMENT OF HIGHWAYS
 ILLINOIS DEPARTMENT OF PUBLIC WORKS AND BUILDINGS
 PROJECTS 124-11(6)38, 124-9(1)10, 124-11(6)11
 BRIDGE OVER OHIO RIVER ON 124
 BETWEEN McCRACKEN COUNTY, KENTUCKY AND MASSAC COUNTY, ILLINOIS

HAZLET & BIRDA Consulting Engineers
 BRIDGE NUMBER 17471
 DRAWING NO. 17471

RIB STRESS UNIT V

CONTRACT: 98990
 ROUTE: INTERSTATE 24
 SECTION: (64-3B) I-6
 COUNTY: MASSAC, IL; McCracken, KY
 SHEET 39 OF 99
 FOR INFORMATION ONLY

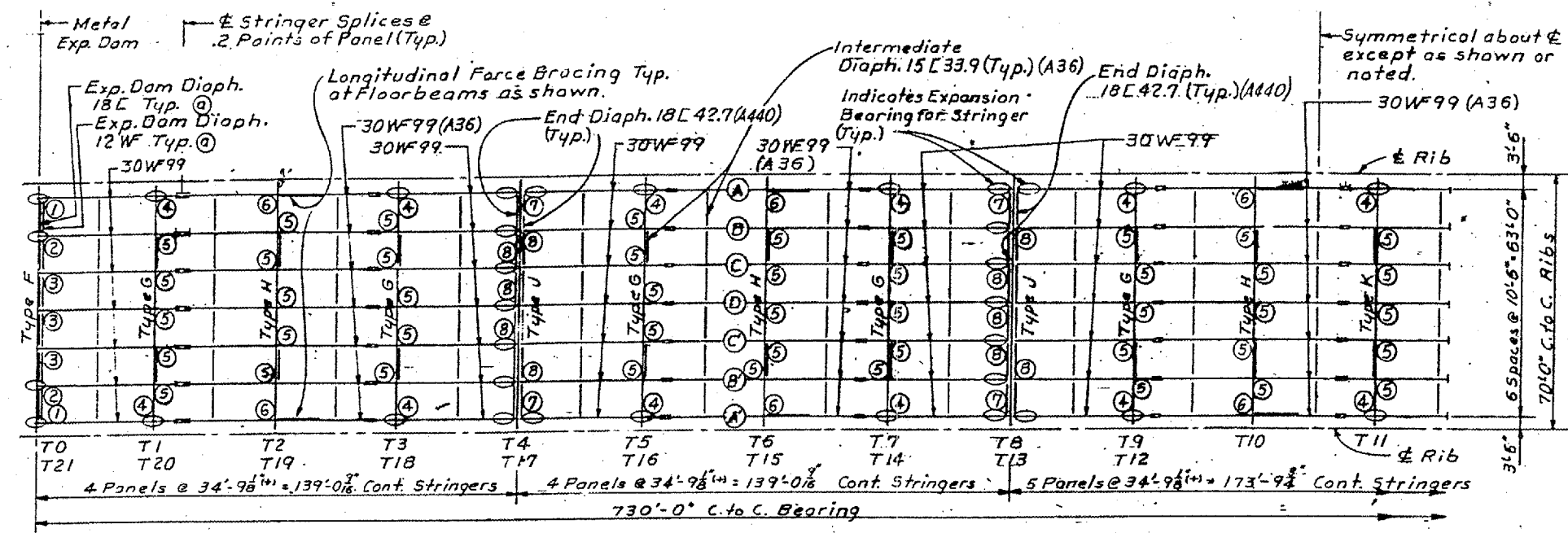

FLOOR SYSTEM FRAMING PLAN

① Indicates Type of Bearings (See Sheet 32)

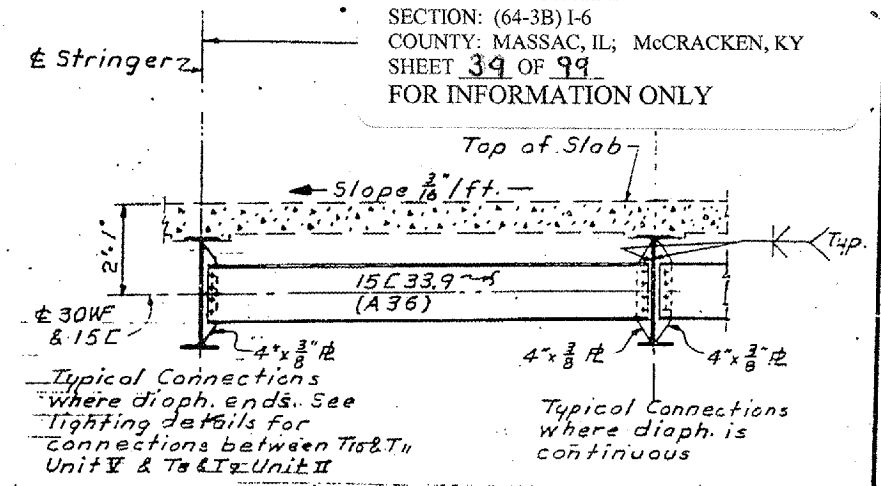

INTERMEDIATE DIAPHRAGM DETAILS

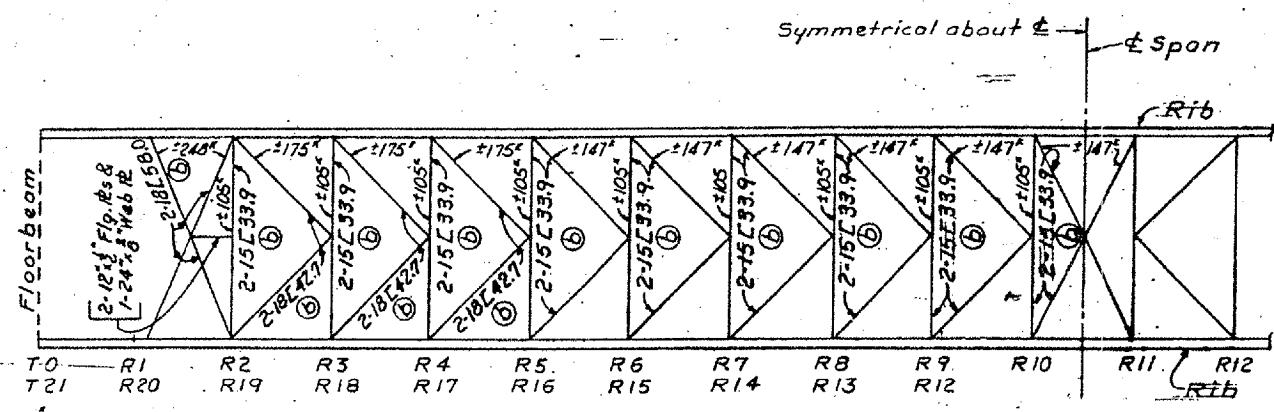

PLAN OF TOP LATERAL BRACING

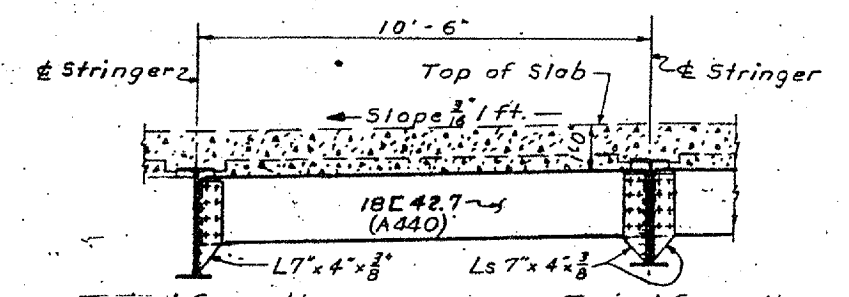

END DIAPHRAGM DETAILS

- NOTE:
- ① See Expansion Dam Detail Sheet for Details.
 - ② See Sheet 46 for details of Stiffeners and Web Plates.
 - ③ All bracing shall be A36 Steel and shall be detailed to the deformed length of the Tie or Rib.
 - ④ Camber Tubes $\frac{1}{8}$ " up For Longitudinal Force Bracing and Stringer Field Splice see Sheet 41.

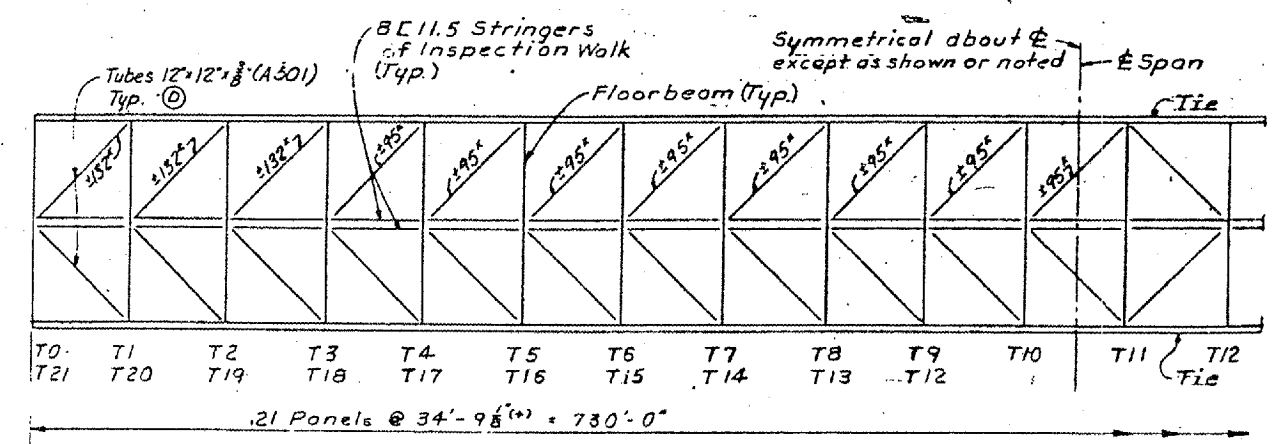

PLAN OF BOTTOM LATERAL BRACING

UNIT V STRUCTURAL STEEL QUANTITIES (LBS)								
Part of Project	Drains	Cable Strand	A36	A440	A441	A514	Shoes	Exp. Dam
124.9(10)	20,951	139,072	1,729,990	21,500	1,013,893	583,318	77,922	70,327

FRAMING PLAN FOR UNIT V STRUCTURAL STEEL

KENTUCKY DEPARTMENT OF HIGHWAYS
 ILLINOIS DEPARTMENT OF PUBLIC WORKS AND BUILDINGS
 PROJECTS 124-11675B, 124-9(1)X, 124-116
 BRIDGE OVER OHIO RIVER ON I24
 BETWEEN MACCRACKEN COUNTY, KENTUCKY
 AND MASSAC COUNTY, ILLINOIS

HAZLET & BIRDA Consulting Engineers
 BRIDGE NUMBER 1747
 DRAWING NO. 1747

PREPARED BY MDC. 7/57 CHECKED BY CHH
 QUANTITIES: 124.9(10) PART 47
 DATE 5-66
 SHEET 56 OF 121

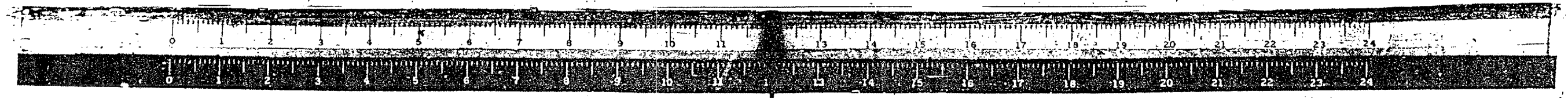

CONTRACT: 98990
 ROUTE: INTERSTATE 24
 SECTION: (64-3B) I-6
 COUNTY: MASSAC, IL; McCracken, KY
 SHEET 40 OF 99
 FOR INFORMATION ONLY

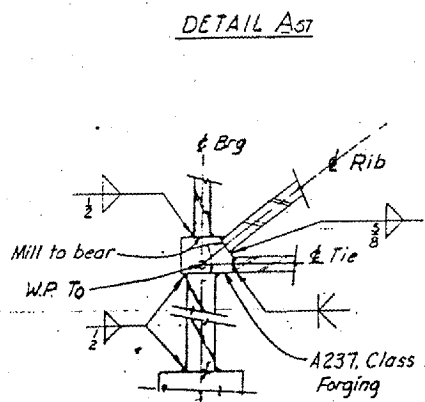
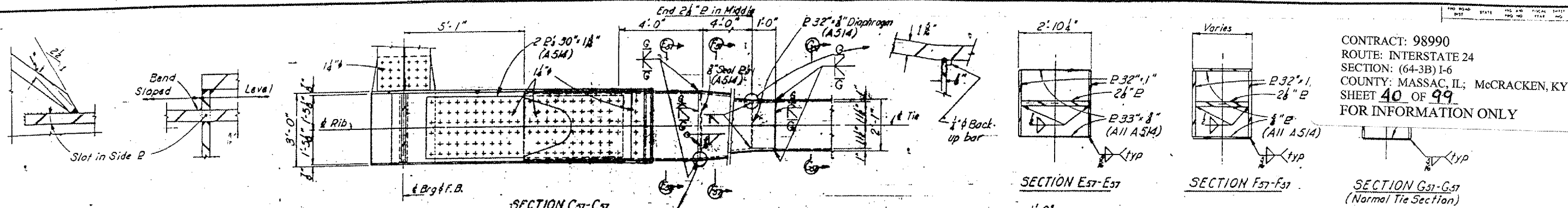

DETAIL A57



WELD DETAIL B57

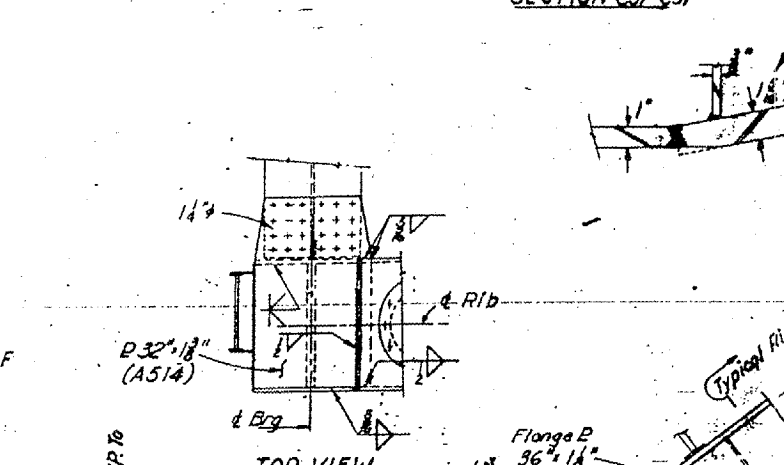

TOP VIEW

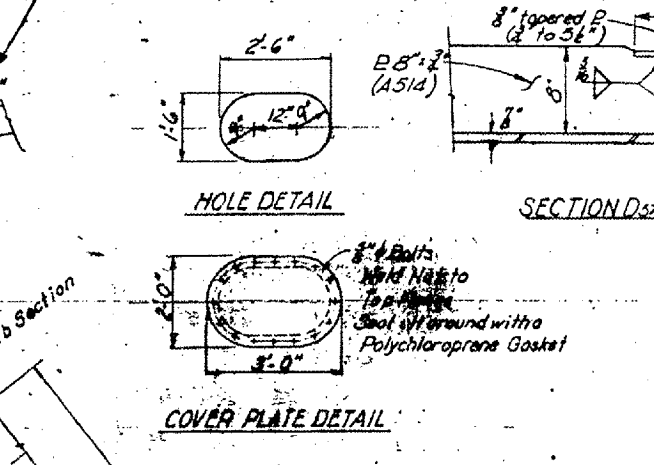

HOLE DETAIL
 COVER PLATE DETAIL

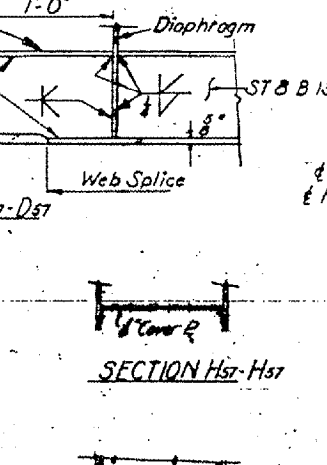

SECTION D57-D57
 SECTION H57-H57

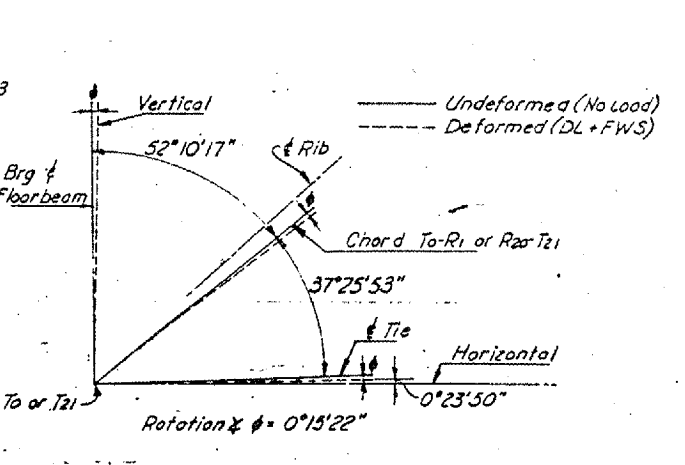

JOINT GEOMETRY

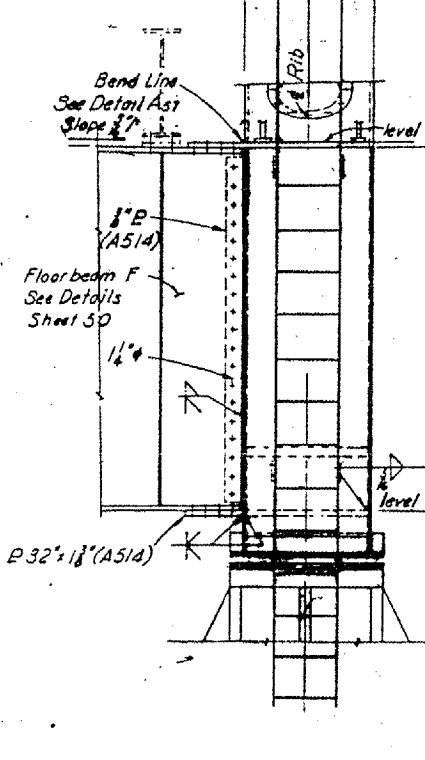

END VIEW

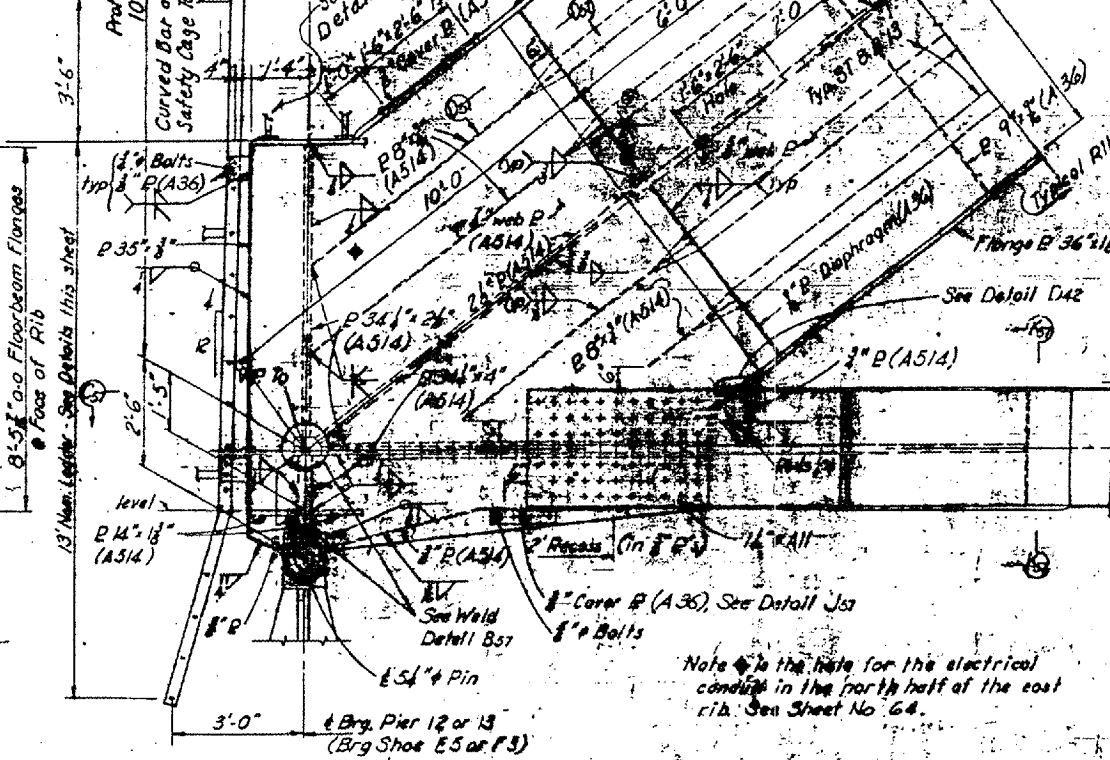

ELEVATION To Pier 12 or 13 (Brg Shoe E5 or F3)

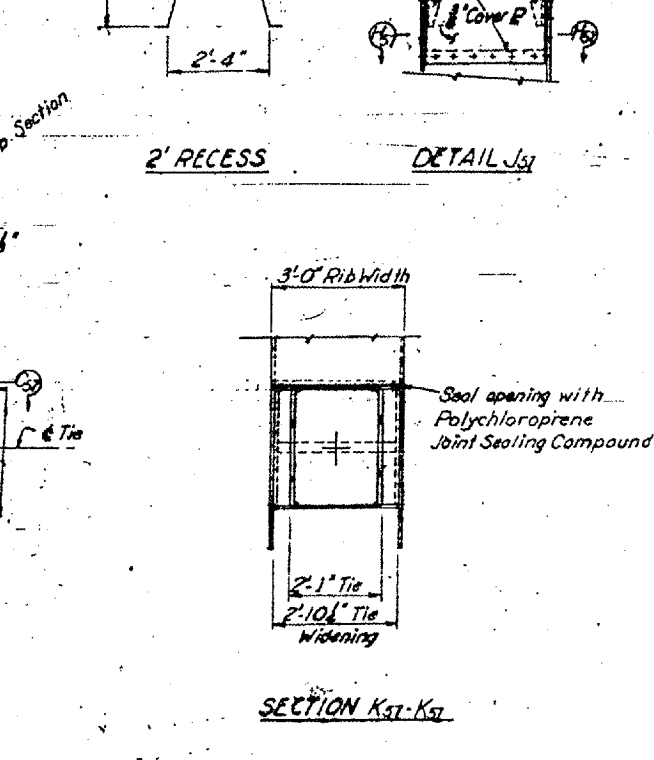

2' RECESS
 DETAIL J57

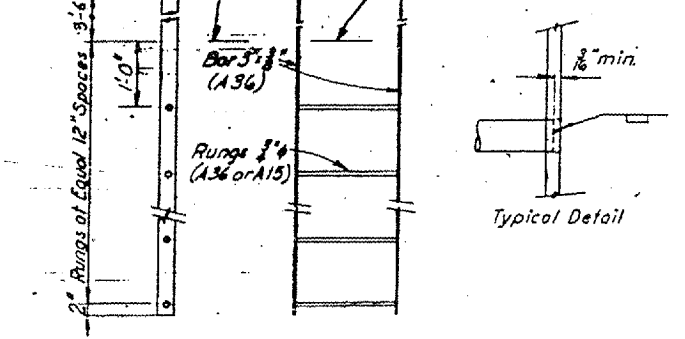

TYPICAL LADDER DETAILS

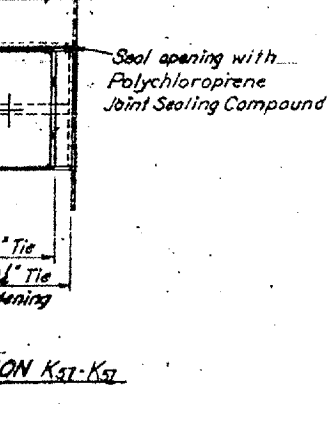

SECTION K57-K57

Note: In the Note for the electrical conduit in the north half of the east rib. See Sheet No. 64.

KENTUCKY DEPARTMENT OF HIGHWAYS
 ILLINOIS DEPARTMENT OF PUBLIC WORKS
 AND BUILDINGS
 PROJECTS 124-1(6) 138, 124-9(1) 10, 124-1(6) 11
 BRIDGE OVER OHIO RIVER ON 124
 BETWEEN MACCRACKEN COUNTY, KENTUCKY
 AND MASSAC COUNTY, ILLINOIS

HAZLET & BEEBE
 Consulting Engineers
 P.O. No. 208

BRIDGE NUMBER
 17471

DRAWING NO.
 17471

INDEX

SHEET 37 OF 97

UNIT 7-118
 STRUCTURAL STEEL

CONTRACT: 98990
 ROUTE: INTERSTATE 24
 SECTION: (64-3B) I-6
 COUNTY: MASSAC, IL; McCracken, KY
 SHEET 41 OF 99
 FOR INFORMATION ONLY

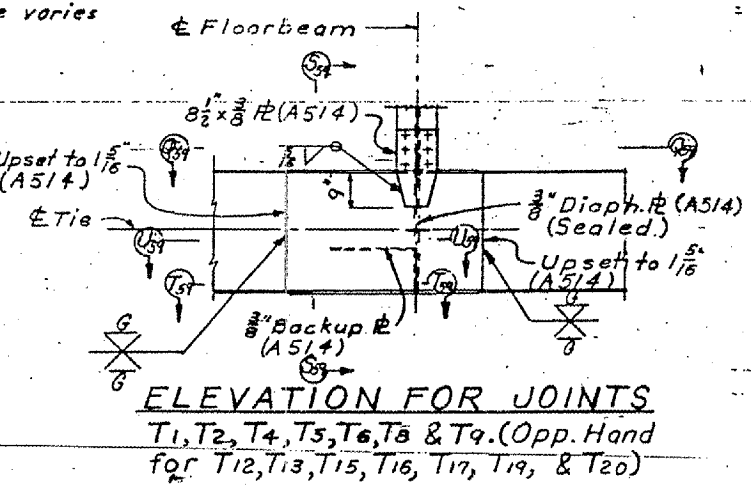
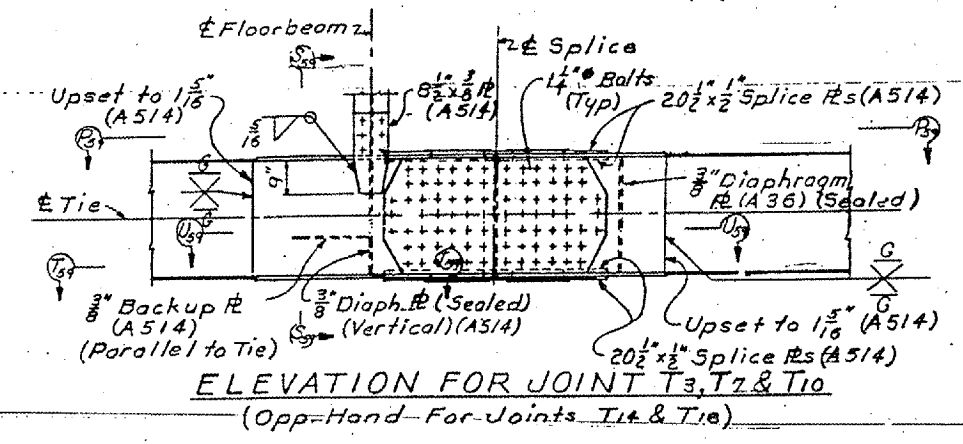
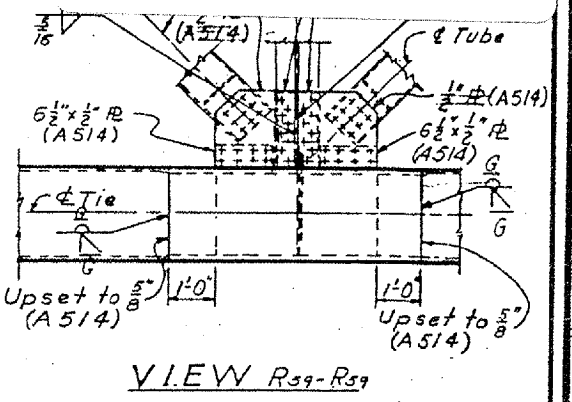
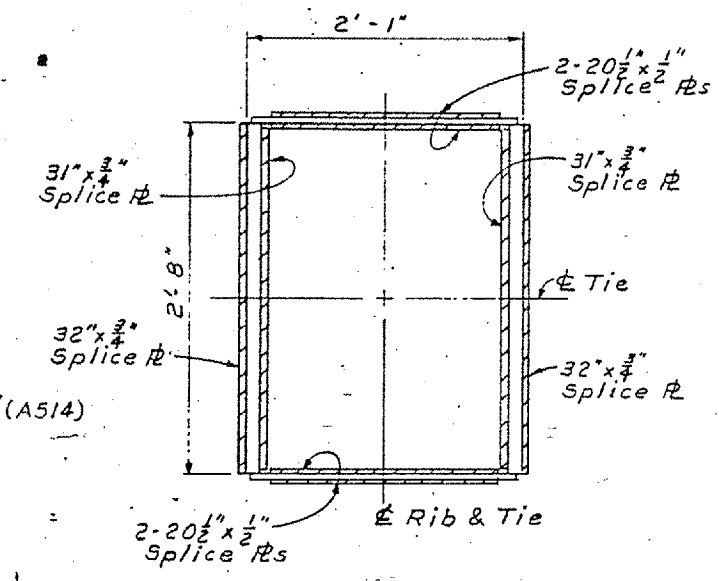
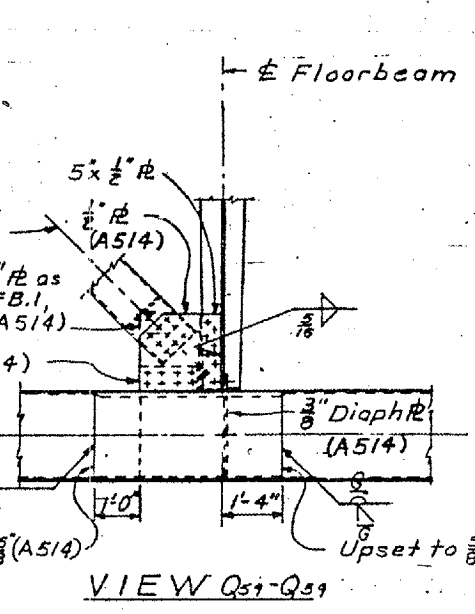
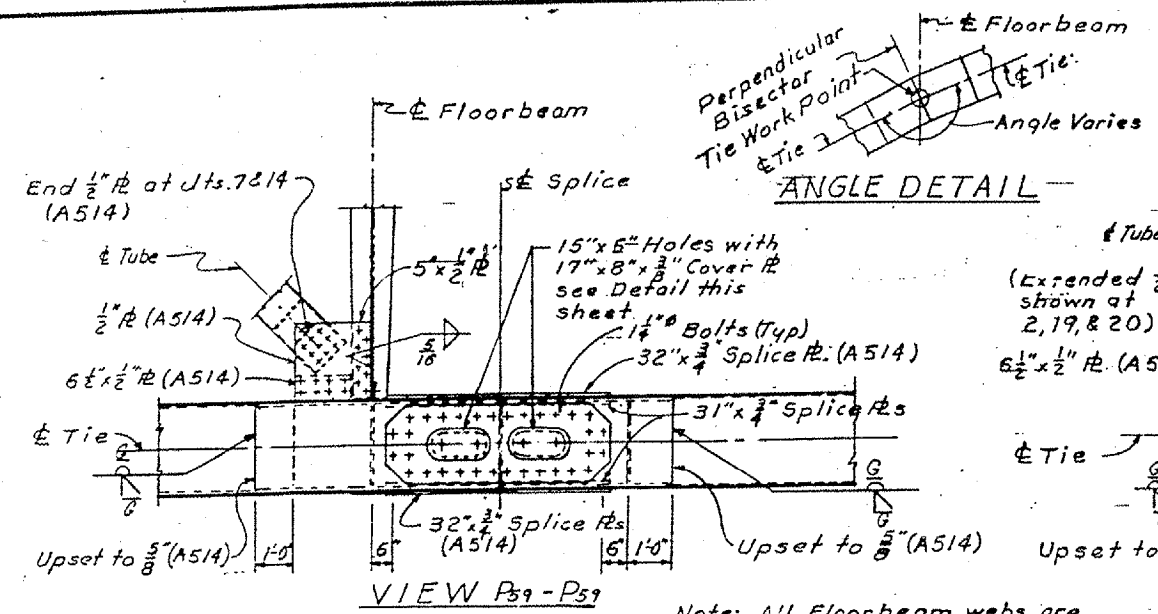

TYPICAL SECTION THRU SPLICE

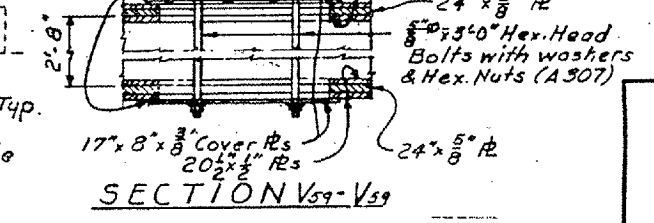
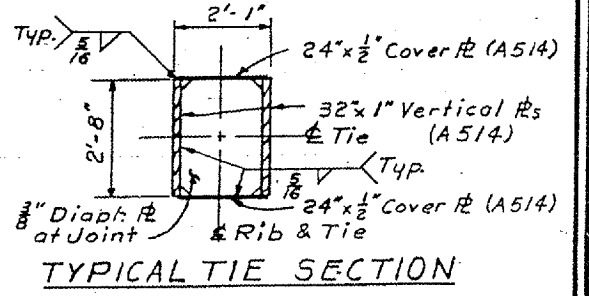
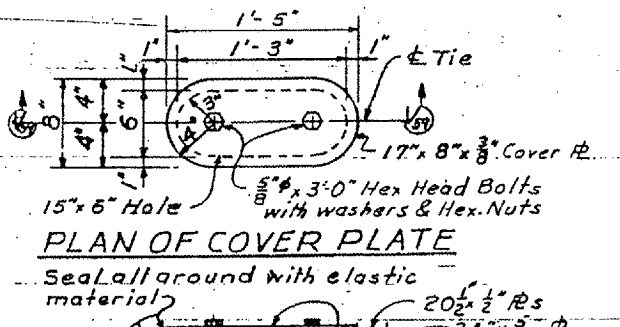
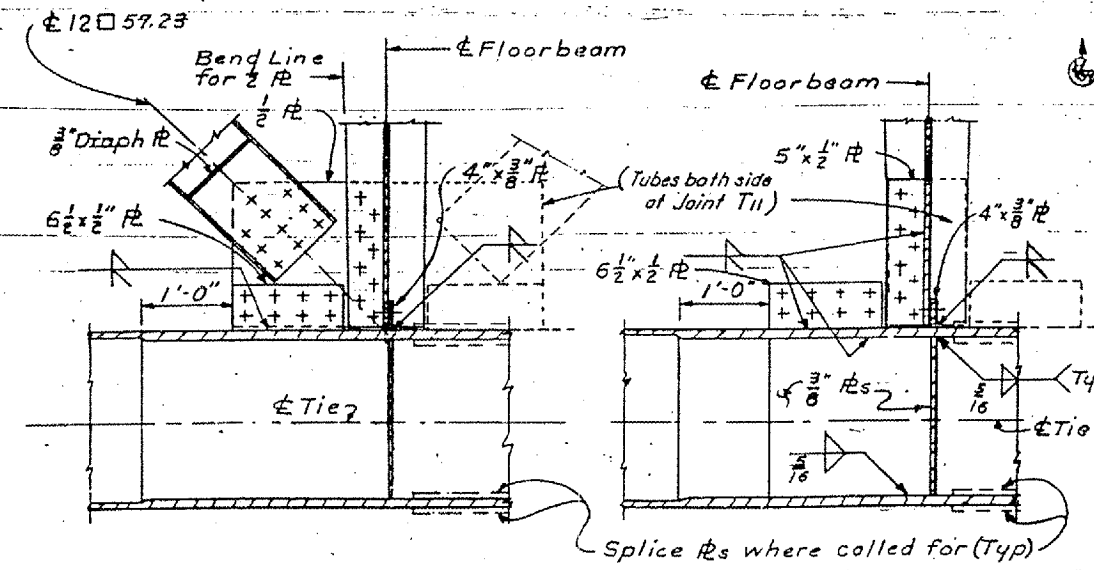
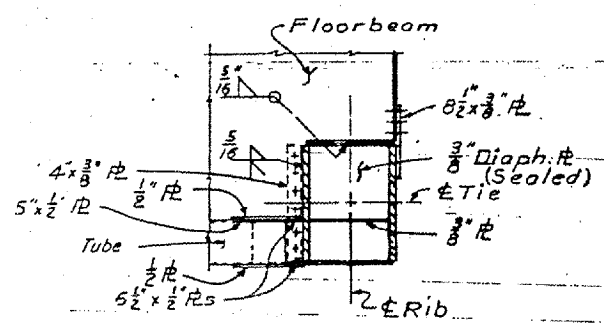
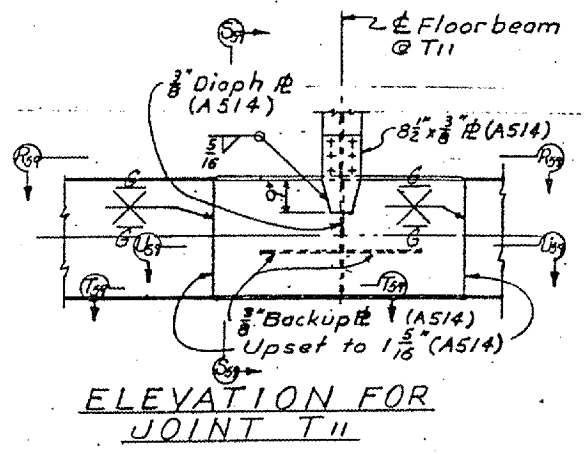

TIE SPLICE DETAILS FOR UNIT V
 STRUCTURAL STEEL

DRAWN BY: J.B.S.
 CHECKED BY: M.D.C.
 DATE: 2/18/67
 PROJECT: BRIDGE OVER OHIO RIVER ON I-24
 BETWEEN MCCRACKEN COUNTY, KENTUCKY AND MASSAC COUNTY, ILLINOIS

KENTUCKY DEPARTMENT OF HIGHWAYS
ILLINOIS DEPARTMENT OF PUBLIC WORKS AND BUILDINGS
 PROJECTS 124-1(6) 138, 124-9(1) 10, 124-1(6) 11
 BRIDGE OVER OHIO RIVER ON I-24
 BETWEEN MCCRACKEN COUNTY, KENTUCKY AND MASSAC COUNTY, ILLINOIS

HAZLET & BRIDAL Consulting Engineers File No. 888	BRIDGE NUMBER	DRAWING NO. 17471	INDEX
---	---------------	----------------------	-------

CONTRACT: 98990
 ROUTE: INTERSTATE 24
 SECTION: (64-3B)1-6
 COUNTY: MASSAC, IL; McCRACKEN, KY
 SHEET 42 OF 99
 FOR INFORMATION ONLY

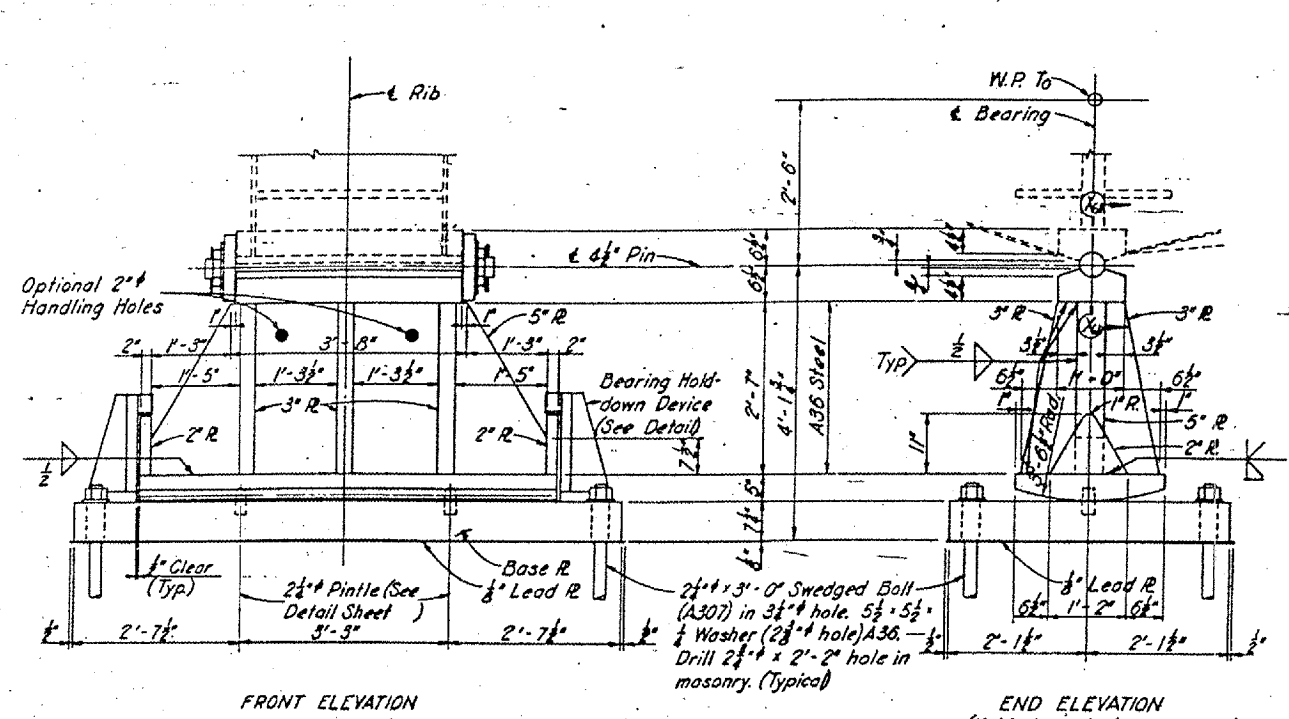

FRONT ELEVATION

END ELEVATION
 (Hold-down devices removed)
BEARING TYPE E-6
 Use at Pier 3 - 2 Req'd

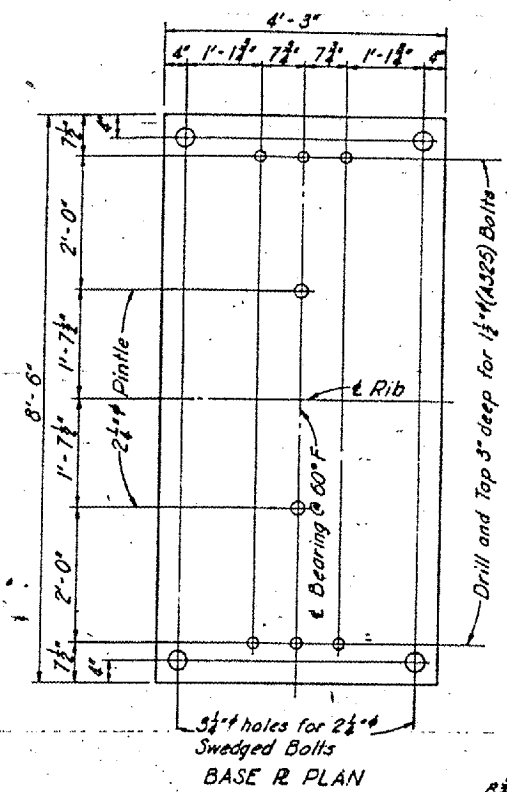

BASE R PLAN

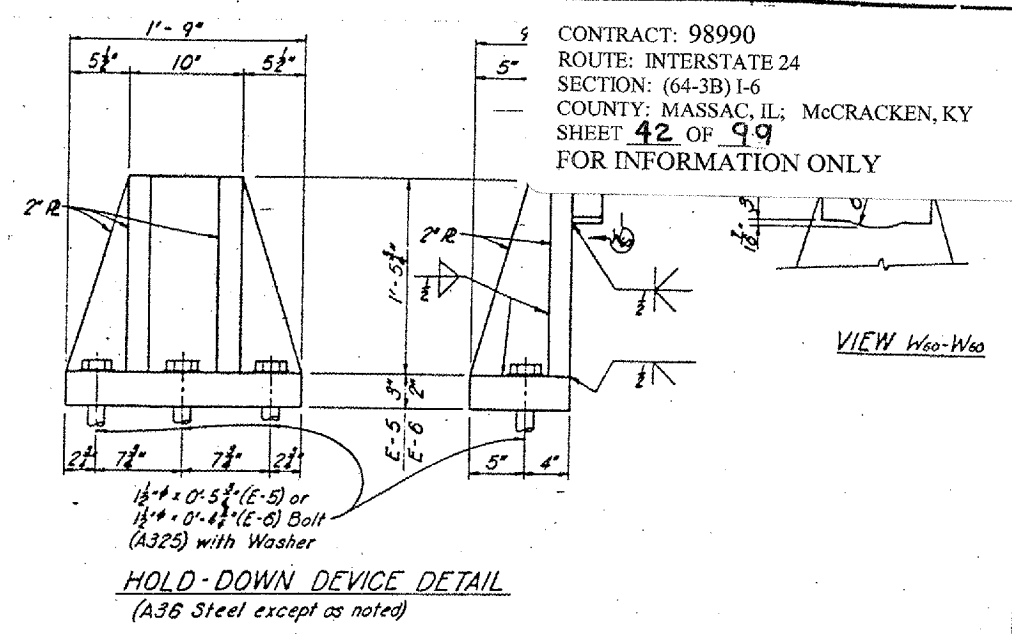

HOLD-DOWN DEVICE DETAIL
 (A36 Steel except as noted)

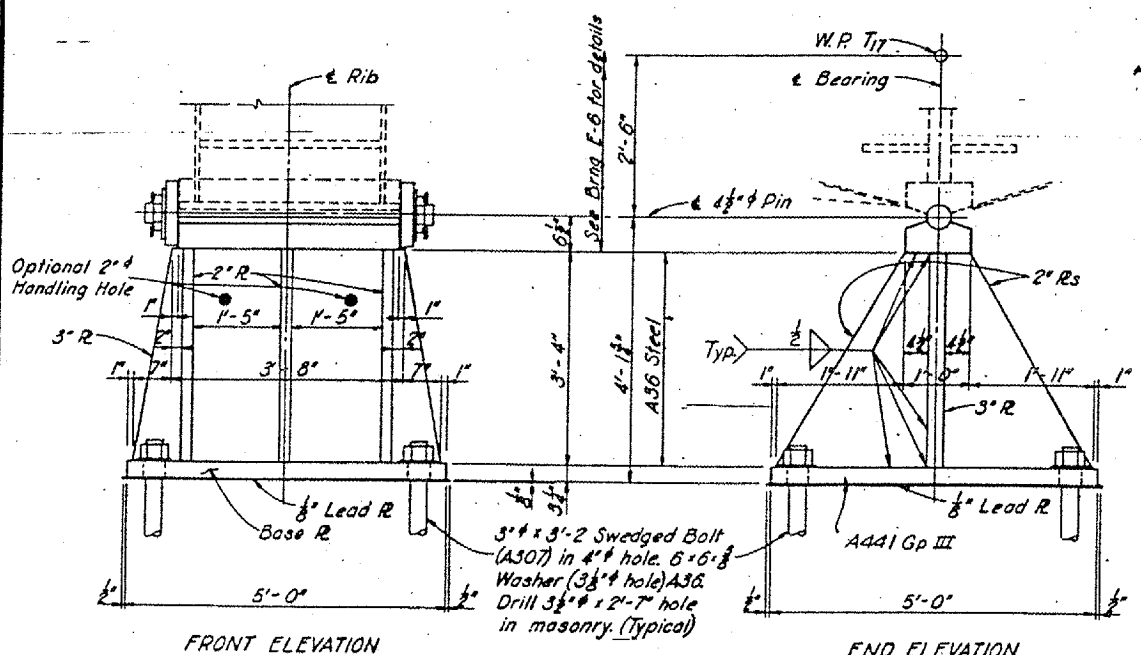
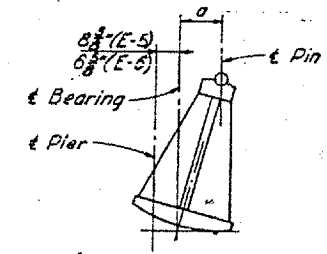

FRONT ELEVATION

END ELEVATION
BEARING TYPE F-4
 Use at Pier 4 - 2 Req'd

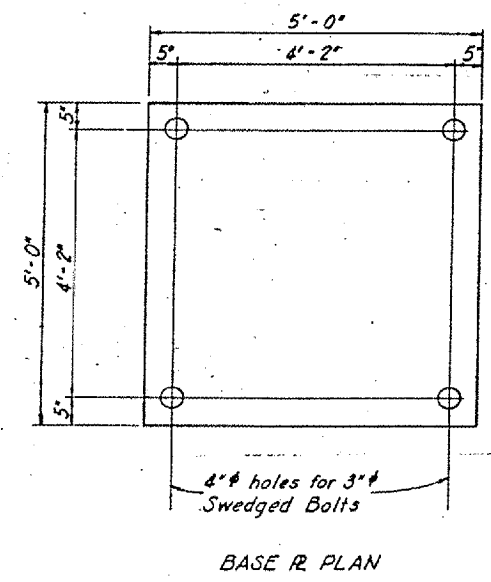

BASE R PLAN

Temperature	a	
	E-5	E-6
-20	-4 3/8"	-3 1/8"
0	-3 3/8"	-2 1/8"
20	-2 1/8"	-1 1/8"
40	-1 1/8"	-1"
60	-	-
80	1 1/8"	1"
100	2 1/8"	1 1/8"
120	3 1/8"	2 1/8"
FWS Expansion	1 1/8"	1 1/8"

Shoes shall be vertical at 60°F after all dead load (including Future Wearing Surface) has been applied.
 For Surface Finishes see sheet 31 for Expansion Bearing and sheet 30 for Fixed Bearing.
 See sheet 30 for White Lead & Tallow, Welding, Anchor Bolts and Setting Masonry Plates Notes.

Bearing	E-5	F-3	E-6	F-4
DL	3044 k	3044 k	2492 k	2492 k
L.L.	455 k	455 k	401 k	401 k
Impact	27 k	27 k	27 k	27 k
Total	3526 k	3528 k	2920 k	2920 k
Max.Ecc.	6.31 in	-	5.06 in	-
Weight	26,295 lbs	12,666 lbs	20,139 lbs	9,518 lbs

BEARING DETAILS
 UNIT II
 STRUCTURAL STEEL

SHEET 60 OF 92

KENTUCKY DEPARTMENT OF HIGHWAYS
ILLINOIS DEPARTMENT OF PUBLIC WORKS
AND BUILDINGS

PROJECTS 124-11(6)358, 124-9(1)10, 124-K(6)11
 BRIDGE OVER OHIO RIVER ON 124
 BETWEEN McCRACKEN COUNTY, KENTUCKY
 AND MASSAC COUNTY, ILLINOIS

HAZLET & BRAD Consulting Engineers P.O. No. 288	BRIDGE NUMBER	DRAWING NO. 1747/	INDEX
---	------------------	----------------------	-------

DRAWN BY: CHH
 CHECKED BY: ELD
 DATE: 5-68
 PROJECT: 124-11(6)358
 SHEET: 42 OF 99

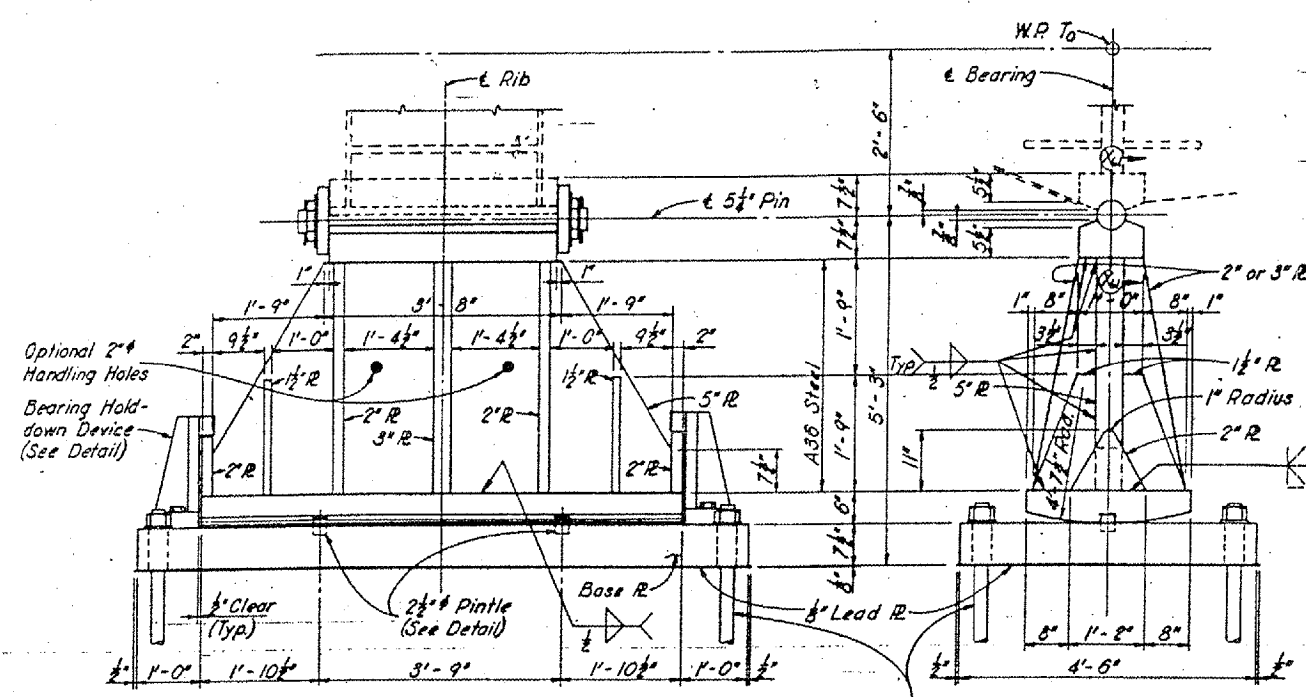

FRONT ELEVATION
 END ELEVATION
 (Hold-down devices removed)
BEARING TYPE E-5
 Use at Pier 12 - 2 Req'd.

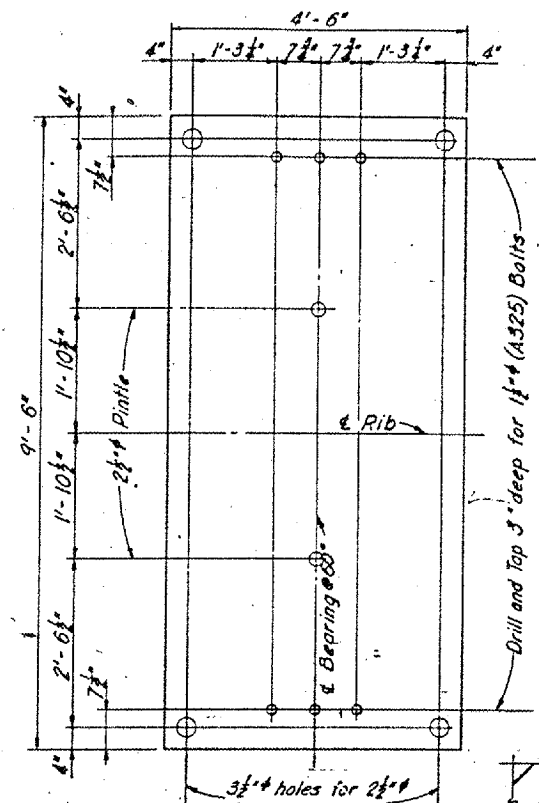

BASE R PLAN

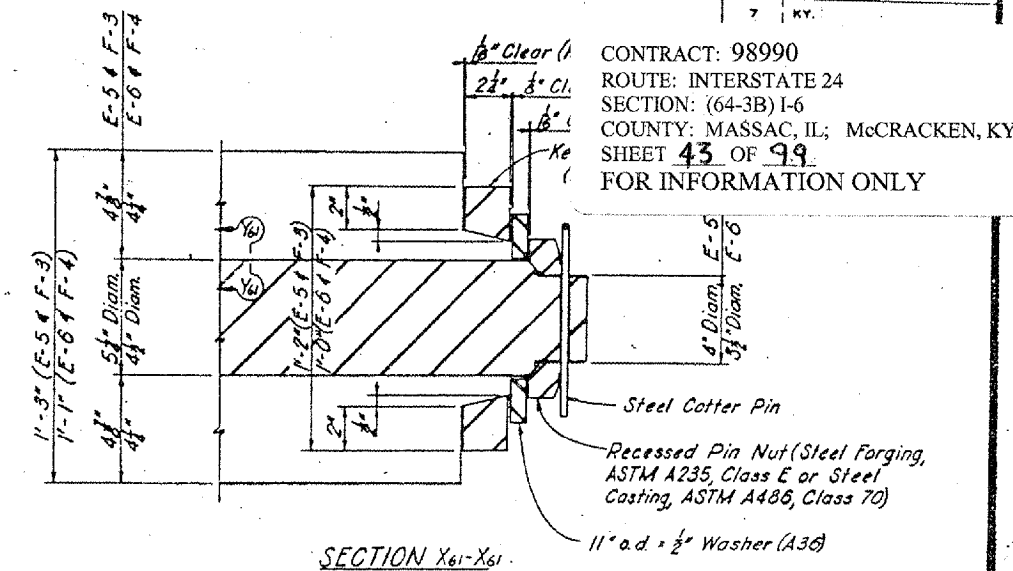

SECTION X61-X61

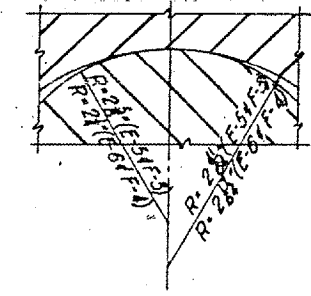

SECTION Y61-Y61

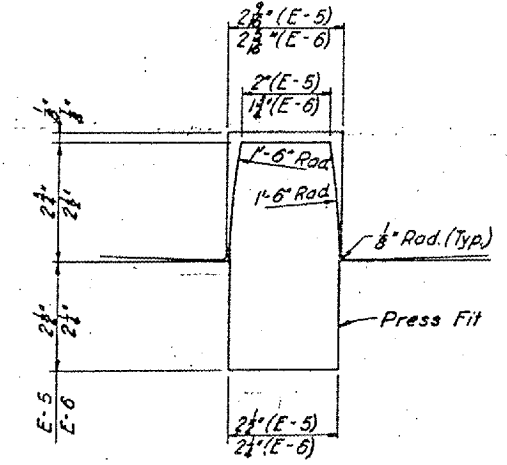

PINTLE DETAIL

Shoes shall be vertical at 60° F after all dead load (including future wearing surface) has been applied. See Sh 60. For Surface Finishes see sheet 31 for Expansion Bearing and sheet 30 for Fixed Bearing. See sheet 30 for "White Lead & Tallow", "Welding", "Anchor Bolts" and "Setting Masonry Plates" Notes.

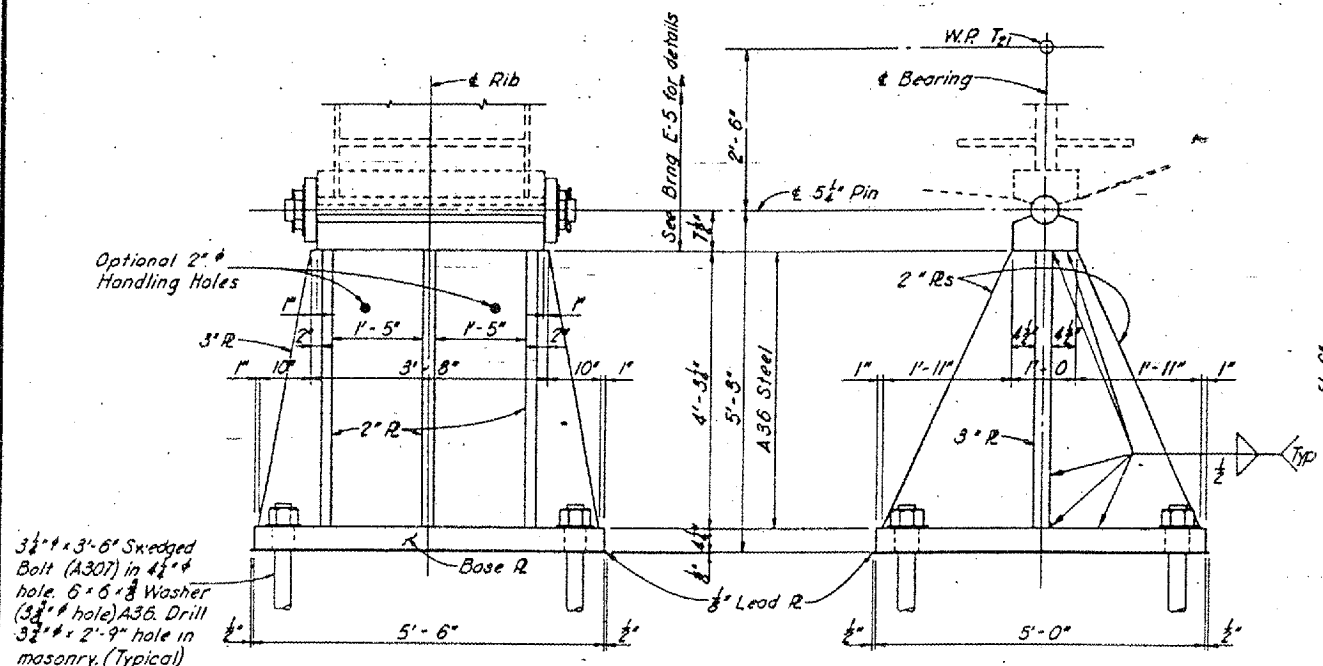

FRONT ELEVATION
 END ELEVATION
BEARING TYPE F-3
 Use at Pier 13 - 2 Req'd.

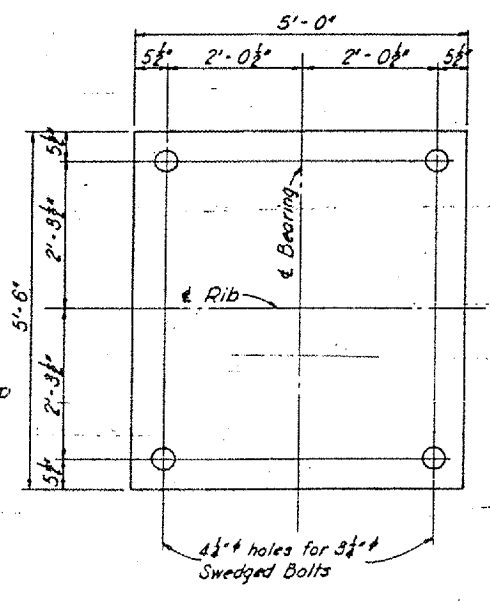

BASE R PLAN

BEARING DETAILS
 UNIT V
 STRUCTURAL STEEL

SHEET 61 OF 121

**KENTUCKY DEPARTMENT OF HIGHWAYS
 ILLINOIS DEPARTMENT OF PUBLIC WORKS
 AND BUILDINGS**

PROJECTS 124-116358, 124-9(1)10, 124-11611
 BRIDGE OVER OHIO RIVER ON 124
 BETWEEN McCRACKEN COUNTY, KENTUCKY
 AND MASSAC COUNTY, ILLINOIS

HAZLET & ENGAL Consulting Engineers PH: No. 588	BRIDGE NUMBER 17471	DRAWING NO. 17471	INDEX
---	---------------------------	----------------------	-------

CONTRACT: 98990
 ROUTE: INTERSTATE 24
 SECTION: (64-3B) I-6
 COUNTY: MASSAC, IL; McCRACKEN, KY
 SHEET 44 OF 99
 FOR INFORMATION ONLY

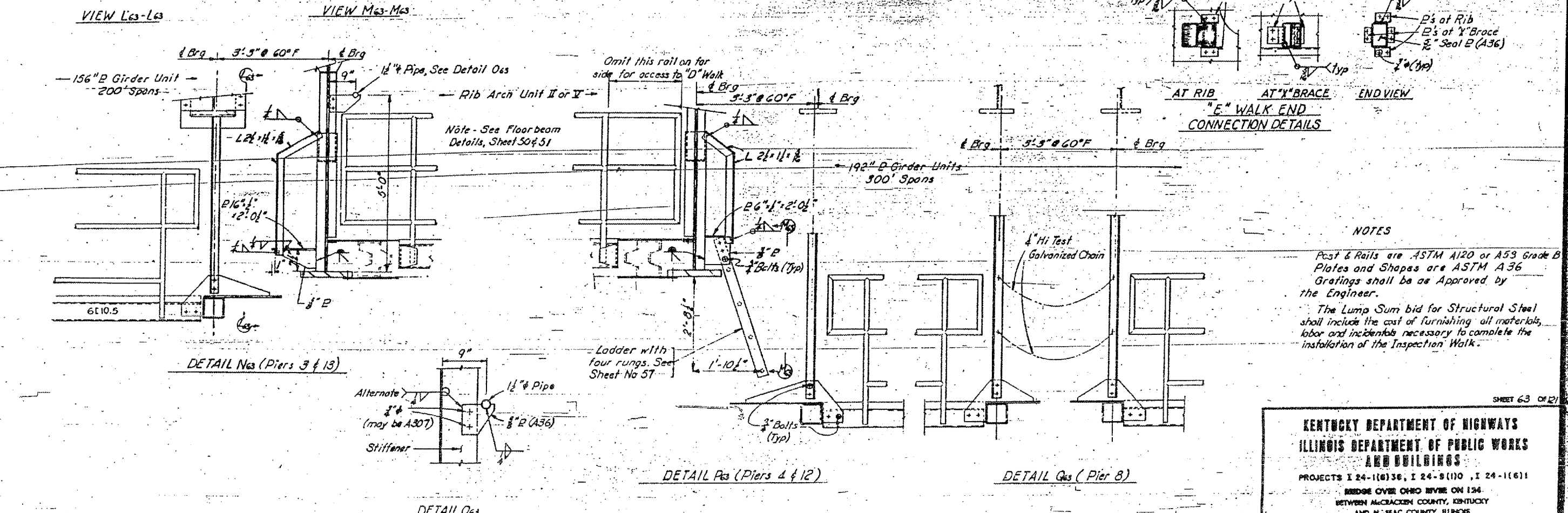
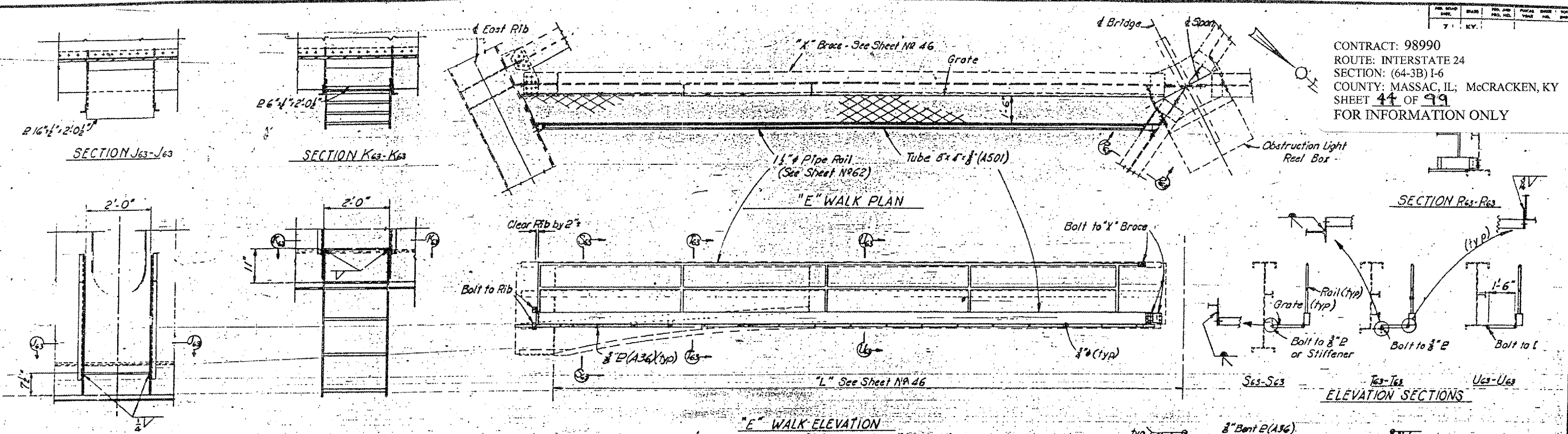

NOTES

Post & Rails are ASTM A120 or A53 Grade B
 Plates and Shaps are ASTM A36
 Graftings shall be as Approved by
 the Engineer.

The Lump Sum bid for Structural Steel
 shall include the cost of furnishing all materials,
 labor and incidentals necessary to complete the
 installation of the Inspection Walk.

SHEET 63 OF 121

**KENTUCKY DEPARTMENT OF HIGHWAYS
 ILLINOIS DEPARTMENT OF PUBLIC WORKS
 AND BUILDINGS**

PROJECTS I 24-1(10)36, I 24-8(110), I 24-1(16)1
 BRIDGE OVER OHIO RIVER ON I 24
 BETWEEN McCRACKEN COUNTY, KENTUCKY
 AND MASSAC COUNTY, ILLINOIS

HAZLET & BIRDAI Consulting Engineers P.O. No. 265	BRIDGE NUMBER	DRAWING NO. 17471
---	------------------	----------------------

**INSPECTION WALK
 STRUCTURAL STEEL**

DRAWN BY: R.B.S.
 CHECKED BY: C.H.H.
 DATE: 11/24/64

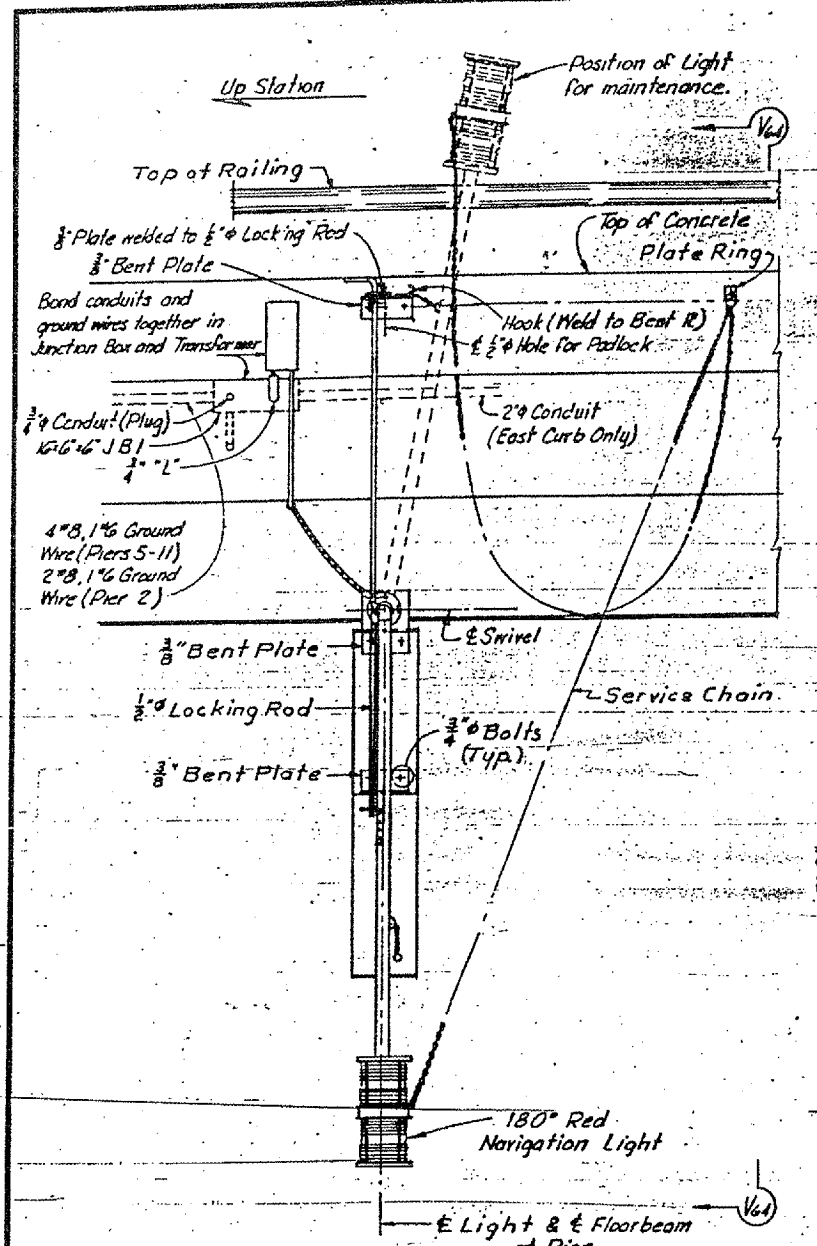

TYPICAL WIRING FOR NAVIGATION LIGHTS AT PIERS 2 & 5 THRU 11 (East Side Shown)

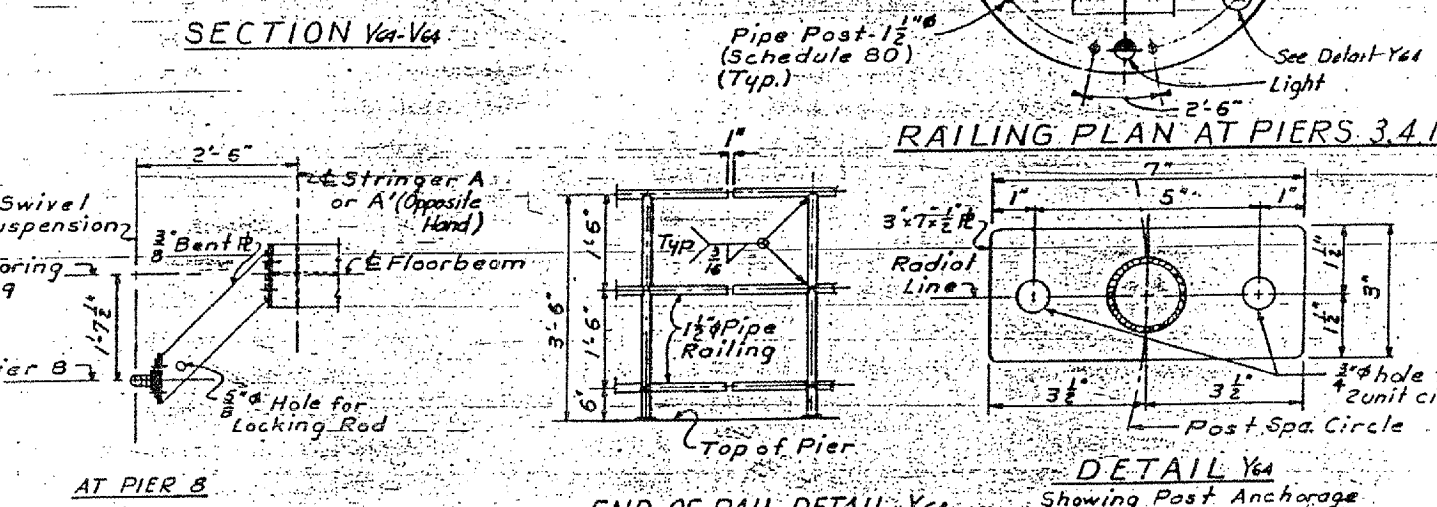
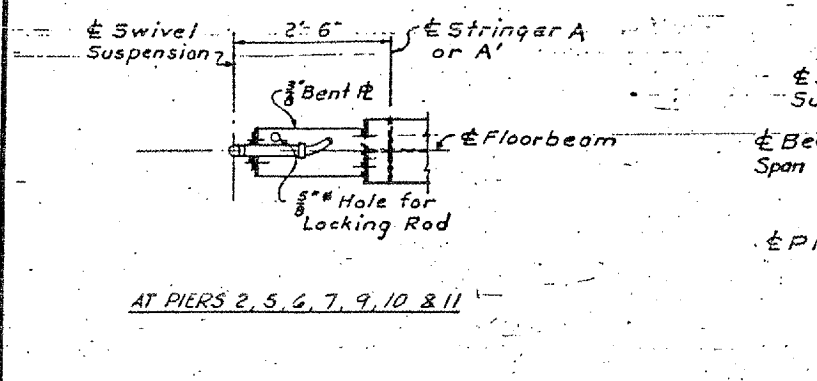
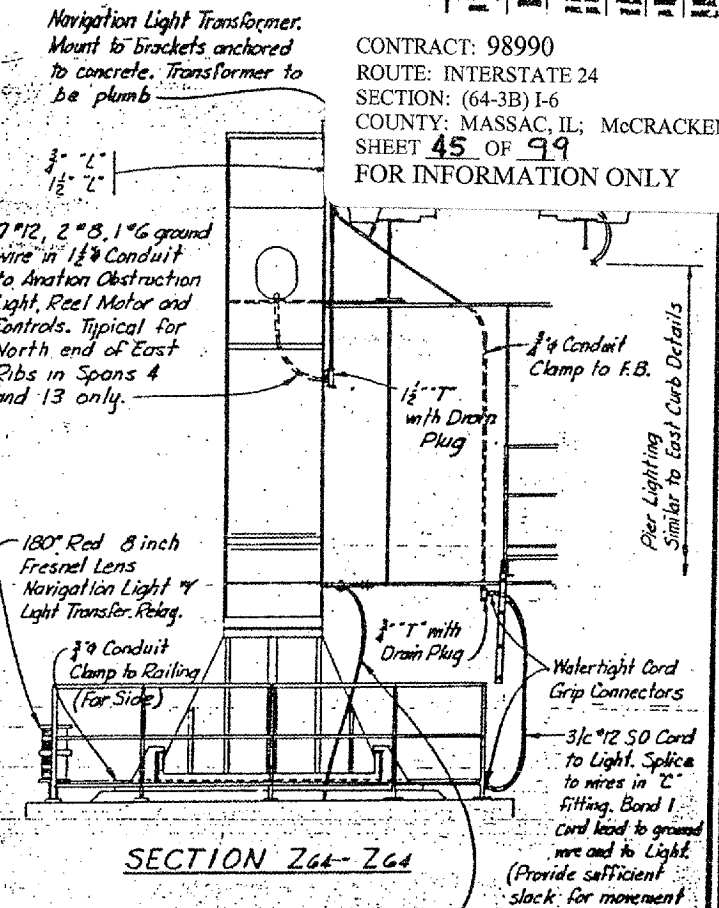
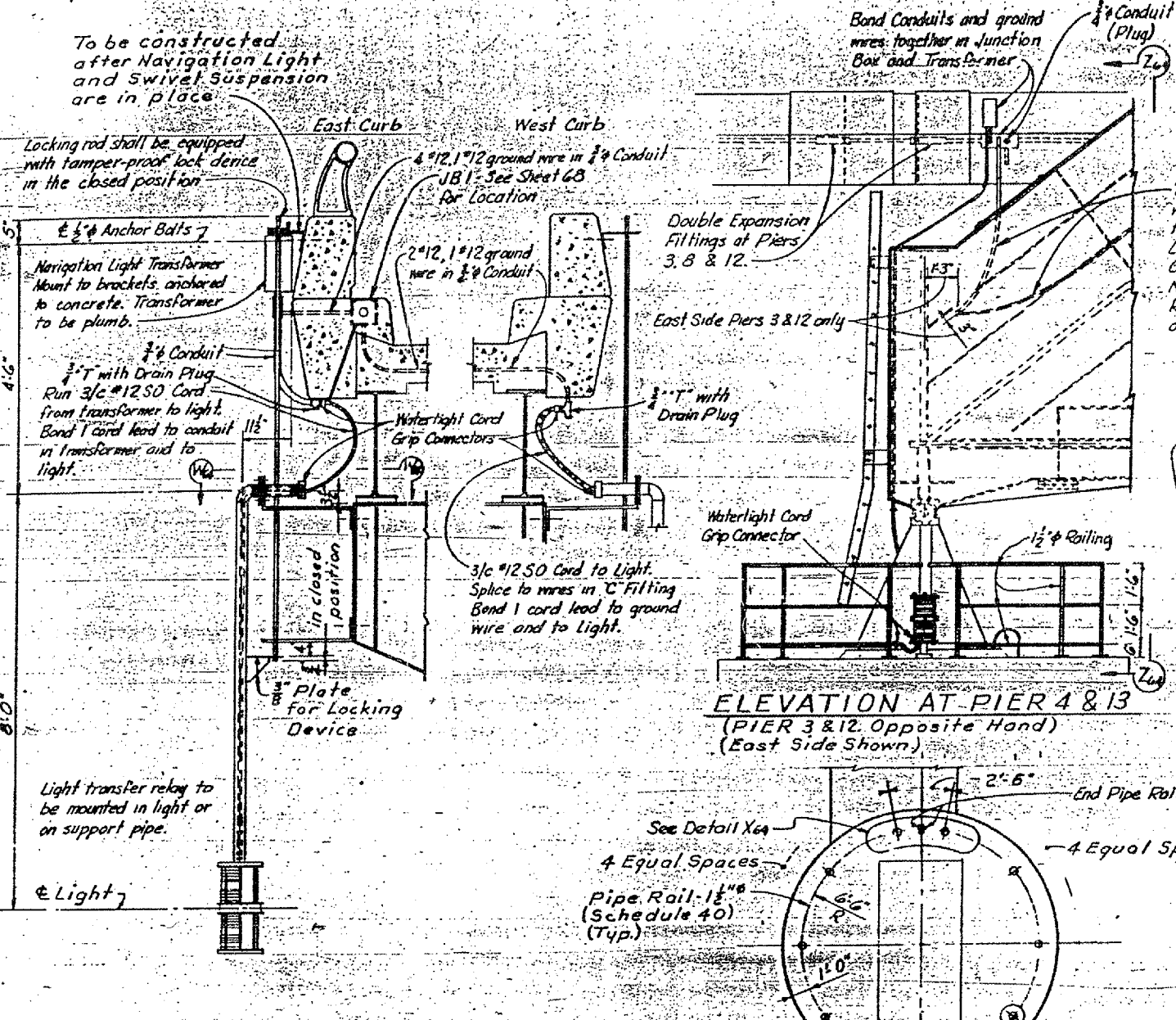

SECTION Wee-Wee

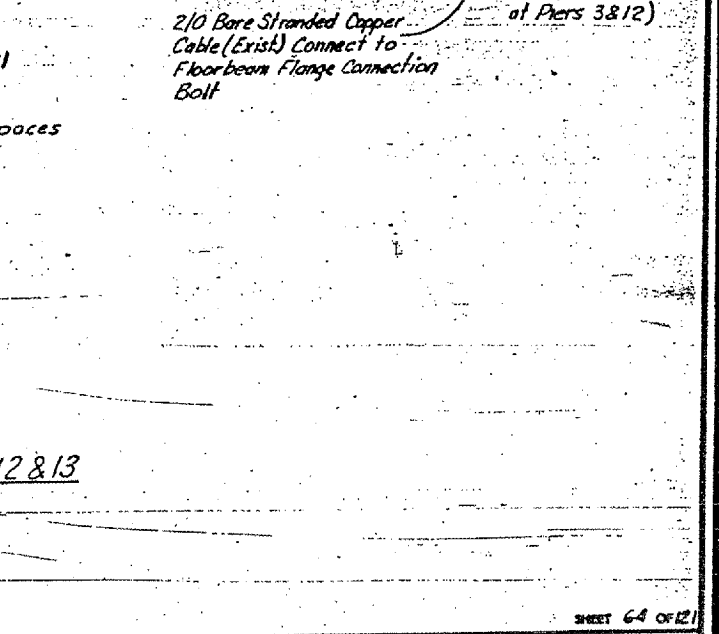

SHEET 64 OF 121

**KENTUCKY DEPARTMENT OF HIGHWAYS
 ILLINOIS DEPARTMENT OF PUBLIC WORKS
 AND BUILDINGS**

PROJECTS: 24-11(6) 328, 24-9(1) 10, 24-11(6) 11
 BRIDGE OVER OHIO RIVER ON I-24
 BETWEEN McCRACKEN COUNTY, KENTUCKY
 AND MASSAC COUNTY, ILLINOIS

HAZLET & BRAD Consulting Engineers File No. 895	BRIDGE NUMBER	DRAWING NO. 17471
---	------------------	----------------------

CONTRACT: 98990
 ROUTE: INTERSTATE 24
 SECTION: (64-3B) I-6
 COUNTY: MASSAC, IL; McCRACKEN, KY
 SHEET 46 OF 99
 FOR INFORMATION ONLY

Jackson Purchase
 R.E.A.

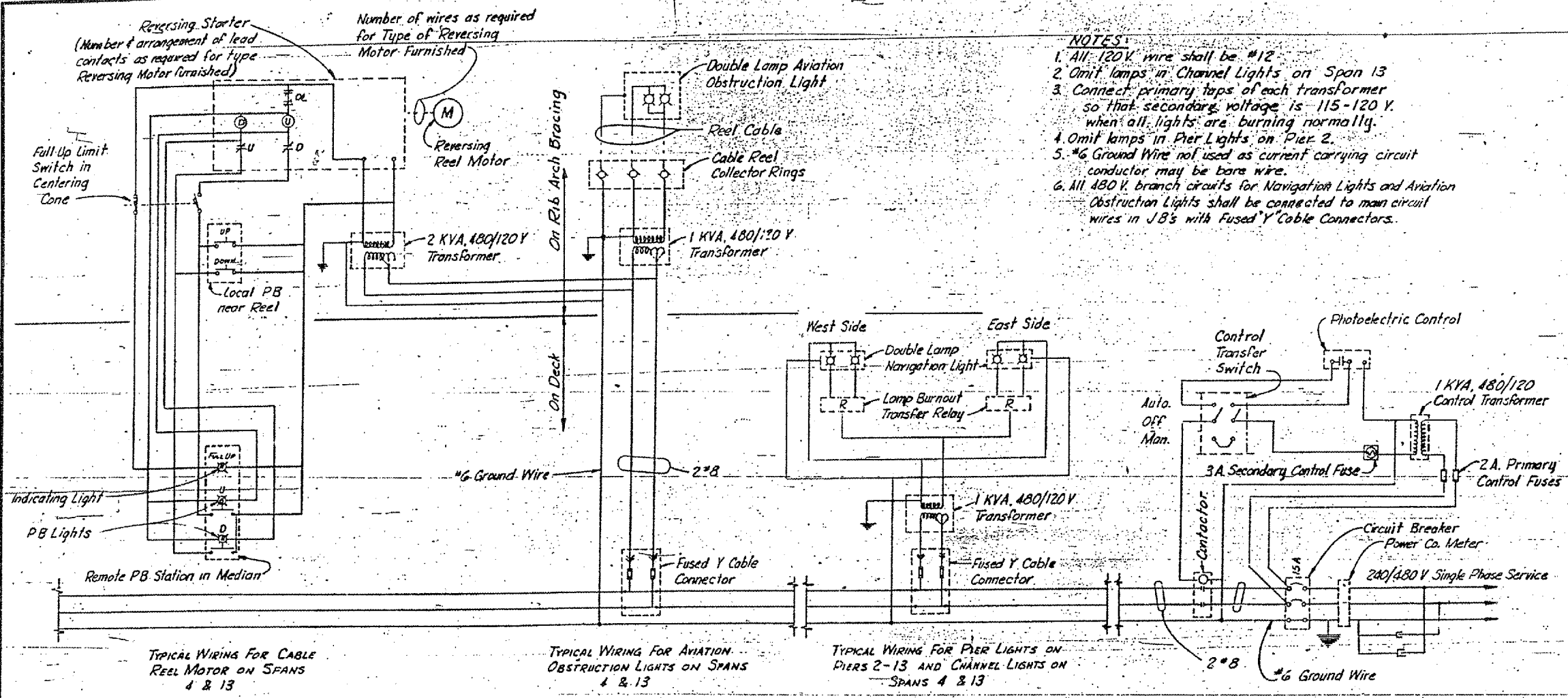

SCHMATIC WIRING DIAGRAM

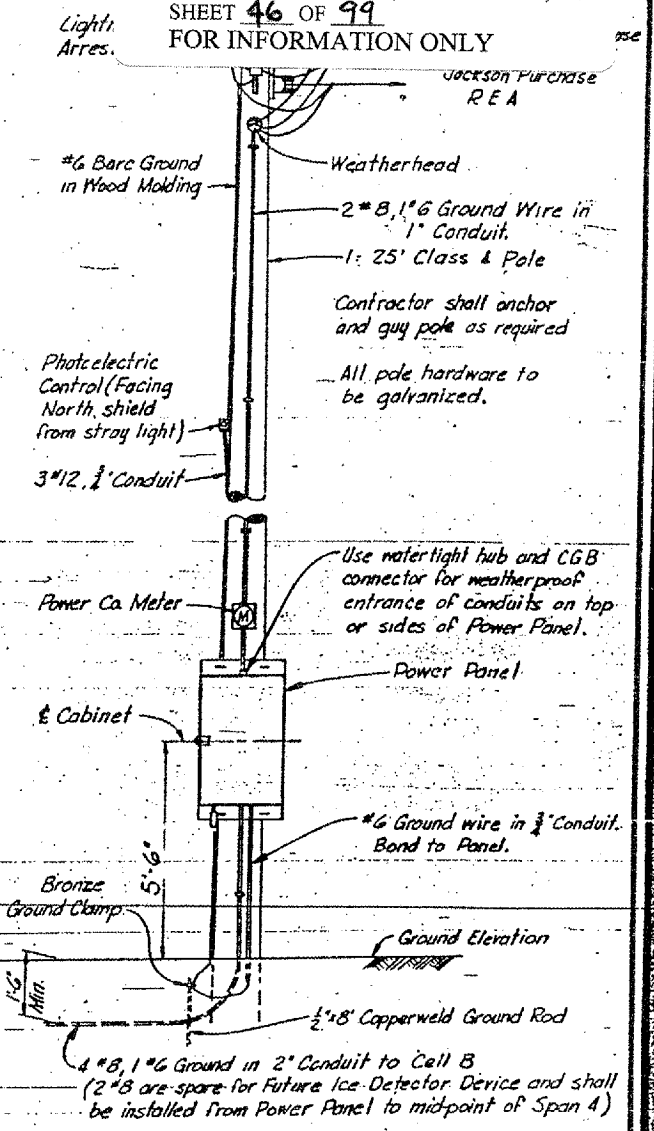

SERVICE AND CONTROL INSTALLATION

Cabinet to be weatherproof and constructed of 12 Ga. steel. All steel to be galvanized. Size of cabinet shall be sufficient for equipment furnished, but shall be at least 39" high x 24" wide x 12" deep. All wiring (except ground wire) between devices shall be in conduit.

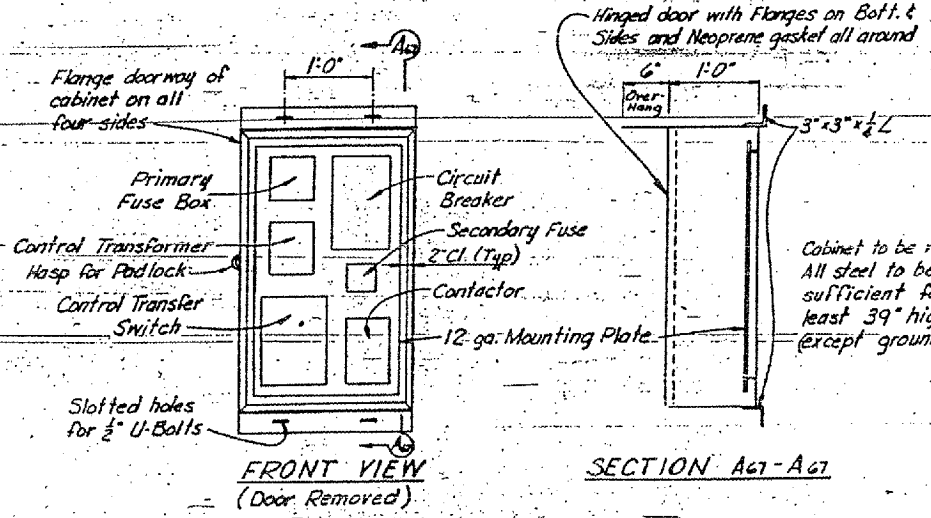

POWER PANEL

LIGHTING DETAILS

KENTUCKY DEPARTMENT OF HIGHWAYS
ILLINOIS DEPARTMENT OF PUBLIC WORKS AND BUILDINGS
 PROJECTS 124-1(6)38, 124-9(1)0, 124-1(6)11
 BRIDGE OVER OHIO RIVER ON I-24
 BETWEEN McCRACKEN COUNTY, KENTUCKY
 AND MASSAC COUNTY, ILLINOIS

HAZLET & BRAD Consulting Engineers P.O. No. 985	BRIDGE NUMBER	DRAWING NO. 17471	INDEX
---	---------------	----------------------	-------

REVISIONS: 1. BY: [Signature] DATE: [Date] 2. BY: [Signature] DATE: [Date] 3. BY: [Signature] DATE: [Date] 4. BY: [Signature] DATE: [Date] 5. BY: [Signature] DATE: [Date] 6. BY: [Signature] DATE: [Date] 7. BY: [Signature] DATE: [Date] 8. BY: [Signature] DATE: [Date] 9. BY: [Signature] DATE: [Date] 10. BY: [Signature] DATE: [Date] 11. BY: [Signature] DATE: [Date] 12. BY: [Signature] DATE: [Date] 13. BY: [Signature] DATE: [Date] 14. BY: [Signature] DATE: [Date] 15. BY: [Signature] DATE: [Date] 16. BY: [Signature] DATE: [Date] 17. BY: [Signature] DATE: [Date] 18. BY: [Signature] DATE: [Date] 19. BY: [Signature] DATE: [Date] 20. BY: [Signature] DATE: [Date] 21. BY: [Signature] DATE: [Date] 22. BY: [Signature] DATE: [Date] 23. BY: [Signature] DATE: [Date] 24. BY: [Signature] DATE: [Date] 25. BY: [Signature] DATE: [Date] 26. BY: [Signature] DATE: [Date] 27. BY: [Signature] DATE: [Date] 28. BY: [Signature] DATE: [Date] 29. BY: [Signature] DATE: [Date] 30. BY: [Signature] DATE: [Date] 31. BY: [Signature] DATE: [Date] 32. BY: [Signature] DATE: [Date] 33. BY: [Signature] DATE: [Date] 34. BY: [Signature] DATE: [Date] 35. BY: [Signature] DATE: [Date] 36. BY: [Signature] DATE: [Date] 37. BY: [Signature] DATE: [Date] 38. BY: [Signature] DATE: [Date] 39. BY: [Signature] DATE: [Date] 40. BY: [Signature] DATE: [Date] 41. BY: [Signature] DATE: [Date] 42. BY: [Signature] DATE: [Date] 43. BY: [Signature] DATE: [Date] 44. BY: [Signature] DATE: [Date] 45. BY: [Signature] DATE: [Date] 46. BY: [Signature] DATE: [Date] 47. BY: [Signature] DATE: [Date] 48. BY: [Signature] DATE: [Date] 49. BY: [Signature] DATE: [Date] 50. BY: [Signature] DATE: [Date] 51. BY: [Signature] DATE: [Date] 52. BY: [Signature] DATE: [Date] 53. BY: [Signature] DATE: [Date] 54. BY: [Signature] DATE: [Date] 55. BY: [Signature] DATE: [Date] 56. BY: [Signature] DATE: [Date] 57. BY: [Signature] DATE: [Date] 58. BY: [Signature] DATE: [Date] 59. BY: [Signature] DATE: [Date] 60. BY: [Signature] DATE: [Date] 61. BY: [Signature] DATE: [Date] 62. BY: [Signature] DATE: [Date] 63. BY: [Signature] DATE: [Date] 64. BY: [Signature] DATE: [Date] 65. BY: [Signature] DATE: [Date] 66. BY: [Signature] DATE: [Date] 67. BY: [Signature] DATE: [Date] 68. BY: [Signature] DATE: [Date] 69. BY: [Signature] DATE: [Date] 70. BY: [Signature] DATE: [Date] 71. BY: [Signature] DATE: [Date] 72. BY: [Signature] DATE: [Date] 73. BY: [Signature] DATE: [Date] 74. BY: [Signature] DATE: [Date] 75. BY: [Signature] DATE: [Date] 76. BY: [Signature] DATE: [Date] 77. BY: [Signature] DATE: [Date] 78. BY: [Signature] DATE: [Date] 79. BY: [Signature] DATE: [Date] 80. BY: [Signature] DATE: [Date] 81. BY: [Signature] DATE: [Date] 82. BY: [Signature] DATE: [Date] 83. BY: [Signature] DATE: [Date] 84. BY: [Signature] DATE: [Date] 85. BY: [Signature] DATE: [Date] 86. BY: [Signature] DATE: [Date] 87. BY: [Signature] DATE: [Date] 88. BY: [Signature] DATE: [Date] 89. BY: [Signature] DATE: [Date] 90. BY: [Signature] DATE: [Date] 91. BY: [Signature] DATE: [Date] 92. BY: [Signature] DATE: [Date] 93. BY: [Signature] DATE: [Date] 94. BY: [Signature] DATE: [Date] 95. BY: [Signature] DATE: [Date] 96. BY: [Signature] DATE: [Date] 97. BY: [Signature] DATE: [Date] 98. BY: [Signature] DATE: [Date] 99. BY: [Signature] DATE: [Date] 100. BY: [Signature] DATE: [Date]

NO.	DATE	BY	REVISION
7	KY.		

CONTRACT: 98990
 ROUTE: INTERSTATE 24
 SECTION: (64-3B) I-6
 COUNTY: MASSAC, IL; McCRACKEN, KY
 SHEET 47 OF 99
 FOR INFORMATION ONLY

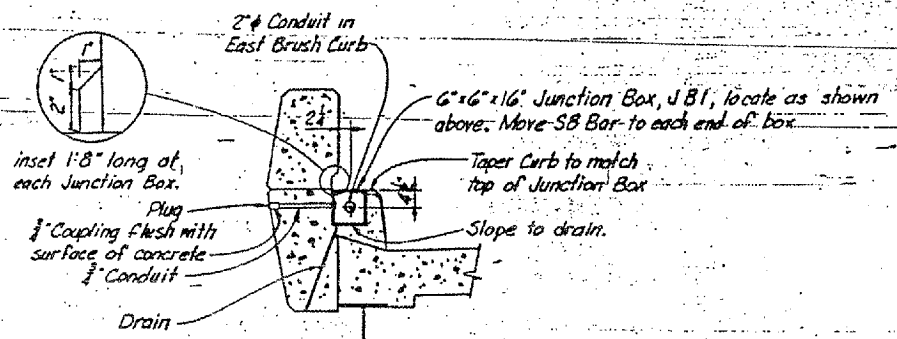
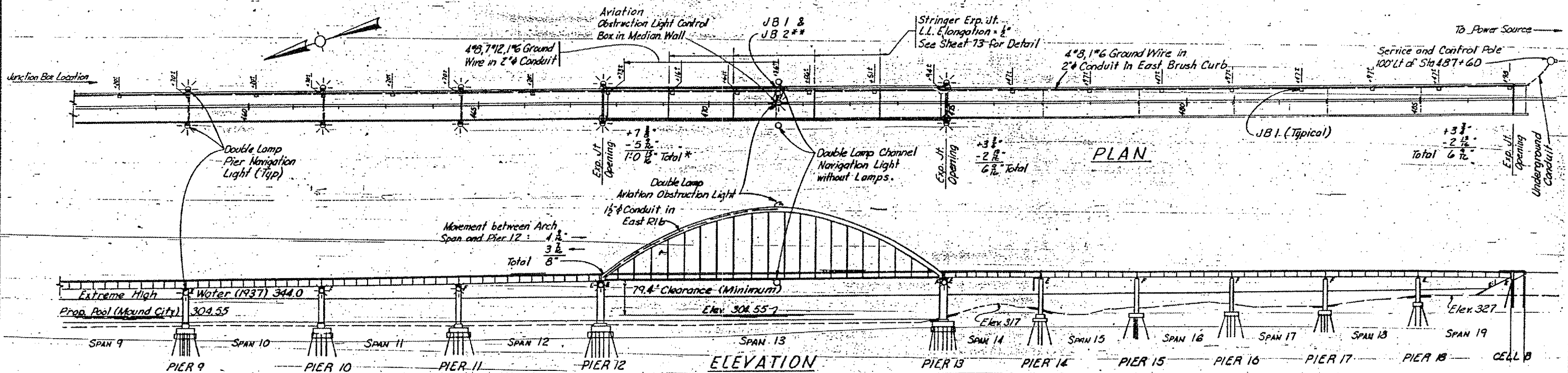
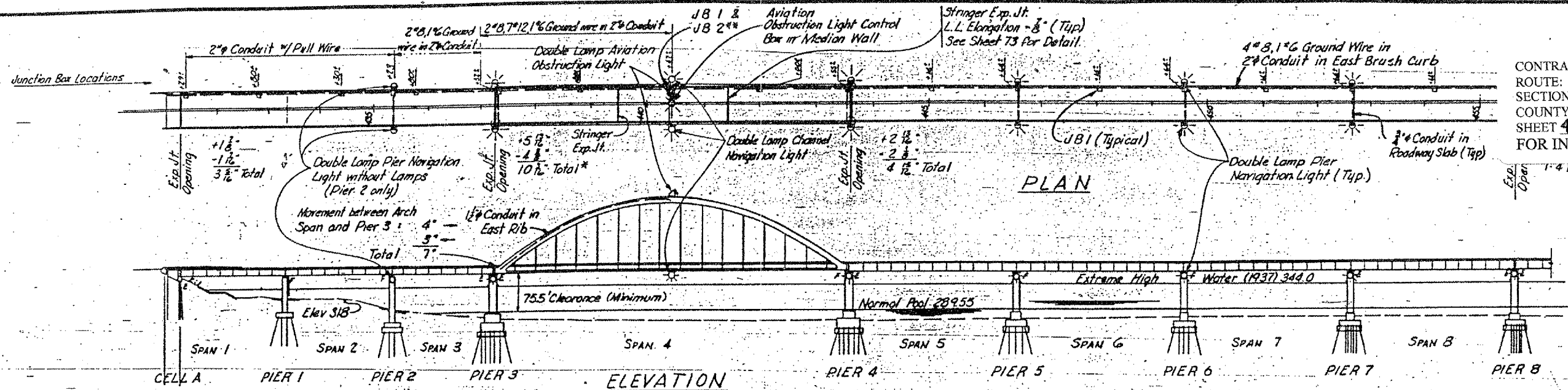

TYPICAL SECTION
 For Conduit and Junction Box Details
 at Light Locations, see Sheets 64 & 65

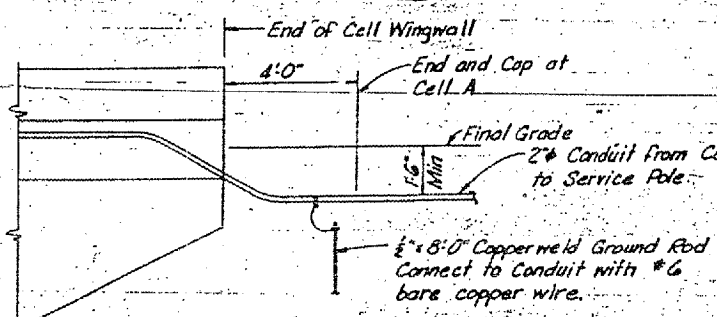

TYPICAL-DETAIL AT
 END OF STRUCTURE

* Double Expansion Fitting required at these Piers (One each side of Expansion Dam - see Sheet 64)
 Note: + indicates joint opening from normal Temp. 60°F.
 - indicates joint closing from normal Temp. 60°F.
 ** Place 1 1/2" Conduit from East Brush Curb to Median Wall.

KENTUCKY DEPARTMENT OF HIGHWAYS
 ILLINOIS DEPARTMENT OF PUBLIC WORKS
 AND BUILDINGS
 PROJECTS 124-116136, 124-116110, 124-116111
 BRIDGE OVER OHIO RIVER ON 124
 BETWEEN McCRACKEN COUNTY, KENTUCKY
 AND MASSAC COUNTY, ILLINOIS

HAUSER & BRAD
 Consulting Engineers
 Pitts. Mo. 635

BRIDGE NUMBER

DRAWING NO. 17471

DATE

LIGHTING DETAILS

CONTRACT: 98990
 ROUTE: INTERSTATE 24
 SECTION: (64-3B)1-6
 COUNTY: MASSAC, IL; McCRACKEN, KY
 SHEET 48 OF 99
 FOR INFORMATION ONLY

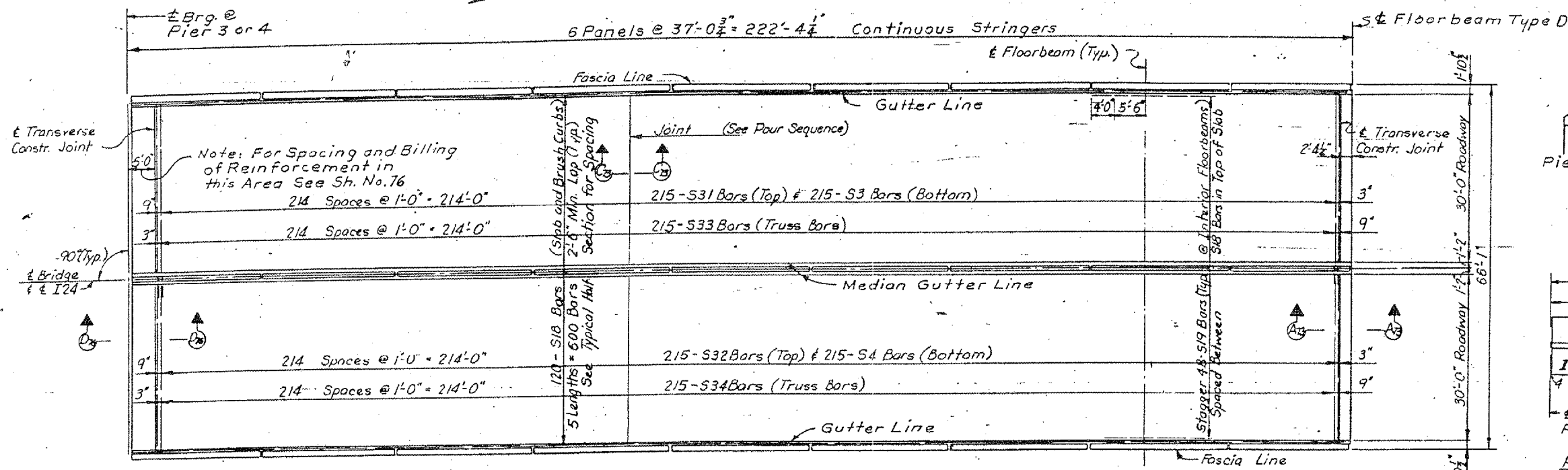

PLAN OF SLAB IIA
 Slab IIC Similar

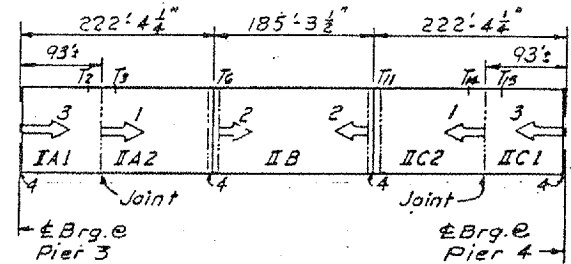
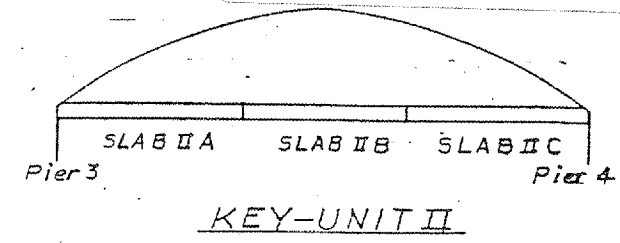

POUR SEQUENCE FOR SLAB
 IN UNIT II

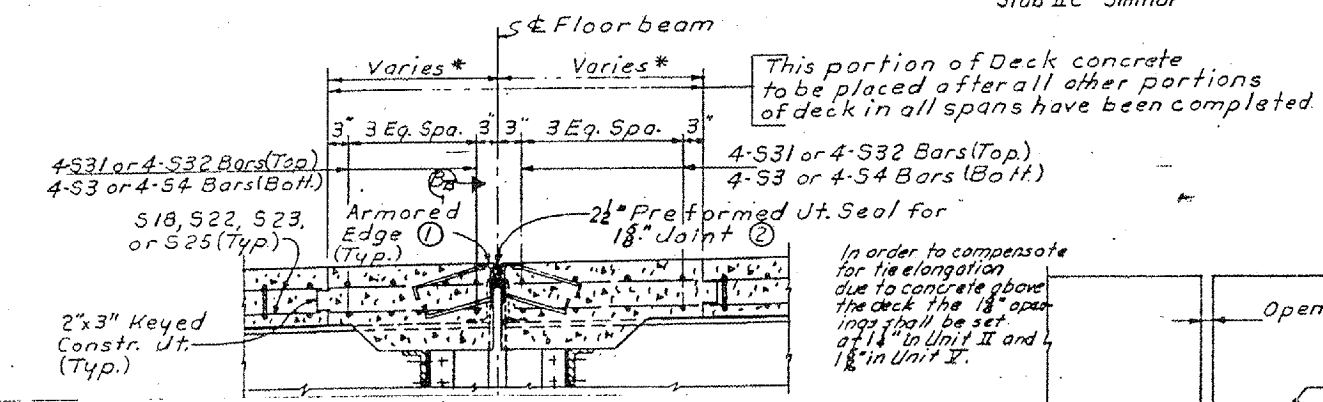

SECTION A73-A73
 (* See plan of slab for Dimensions)

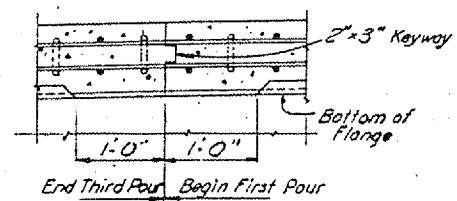

SECTION C73-C75

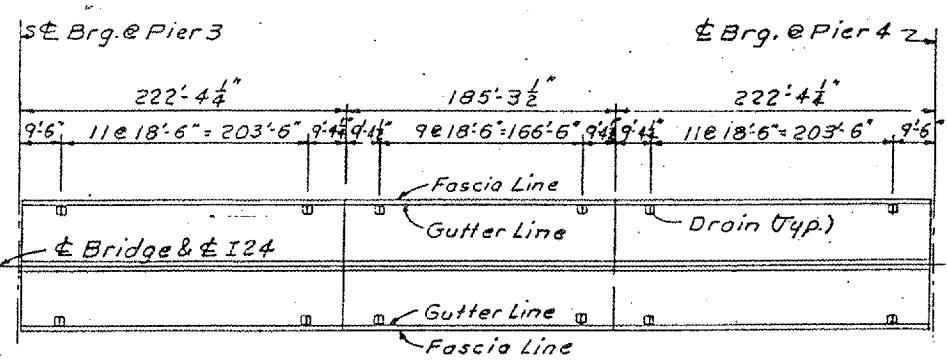

LOCATION FOR FLOOR DRAIN AT UNIT II

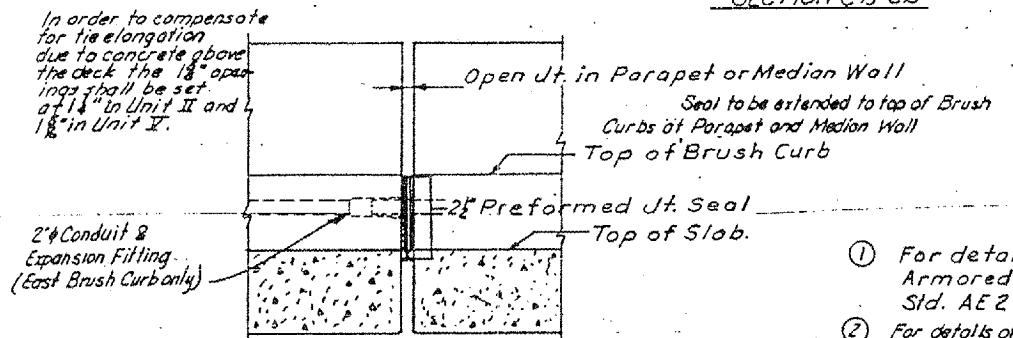

TYPICAL SECTION THRU CURB
 AT STRINGER EXPANSION
 JOINT

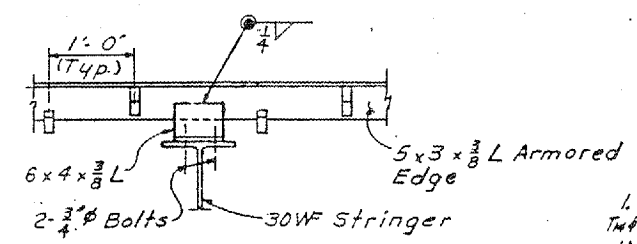

VIEW B73-B73
 Support for Armored
 Edge @ Stringer

- ① For details of Armored Edge see "Standard Armored Edge for Joints in Concrete", Std. AE 2, current edition.
- ② For details of 2 1/2" Preformed Joint Seal, see "Preformed Joint Seal Details for Concrete Bridge Floors", Std. G 353, current edition.

Note: In all pours the concrete shall be placed so as to load the span symmetrically about the center. A variation of 37' (one panel length) max. will be permitted in the simultaneous pours. See the Pour Sequence.

POUR SEQUENCE - UNIT II
 1. Place IA2 and IC2 simultaneously beginning between T2 & T3 and between T4 & T5 and working toward T6 and T7. 2. Place IB starting at T6 and T7 simultaneously and pouring toward the center of the unit. 3. Place IA1 and IC1 simultaneously beginning at T6 and T7 and pouring toward T2 & T3 and T4 & T5. 4. Complete pours adjacent to Expansion Dams and Armored Edges. Set all of the Armored Edges and Expansion Dams before starting these pours. 5. Brush Curbs, Medians, and Parapets need not be placed in the above sequence, but should be kept symmetrical.

SLAB DETAILS
 UNIT II

KENTUCKY DEPARTMENT OF HIGHWAYS
 ILLINOIS DEPARTMENT OF PUBLIC WORKS
 AND BUILDINGS
 PROJECTS: 124-1(6) 138, 124-9(1) 10, 124-1(6) 1
 BRIDGE OVER OHIO RIVER ON I-24
 BETWEEN McCRACKEN COUNTY, KENTUCKY
 AND MASSAC COUNTY, ILLINOIS

HAZLET & ERDAL Consulting Engineers File No. 888	BRIDGE NUMBER	DRAWING NO. 17471	INDEX
--	------------------	----------------------	-------

DRAWN BY: D.B. & R.H. CHECKED BY: D.M.H. DATE: 11/1/54
 DESIGNED BY: M.C.C. FILE NO. 888
 SCALE: AS SHOWN
 SHEET NO. 48 OF 99

CONTRACT: 98990
 ROUTE: INTERSTATE 24
 SECTION: (64-3B)1-6
 COUNTY: MASSAC, IL; McCRACKEN, KY
 SHEET 49 OF 99
 FOR INFORMATION ONLY

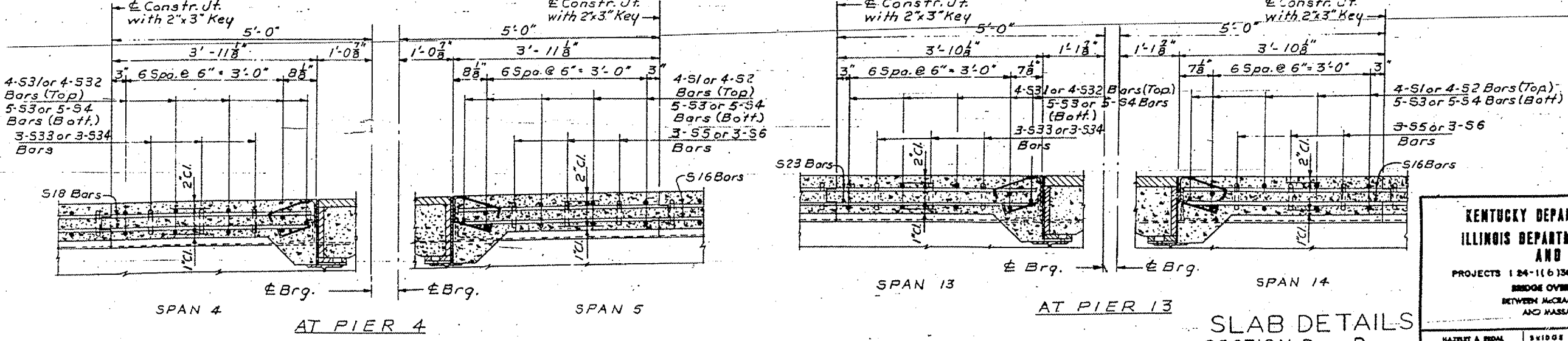
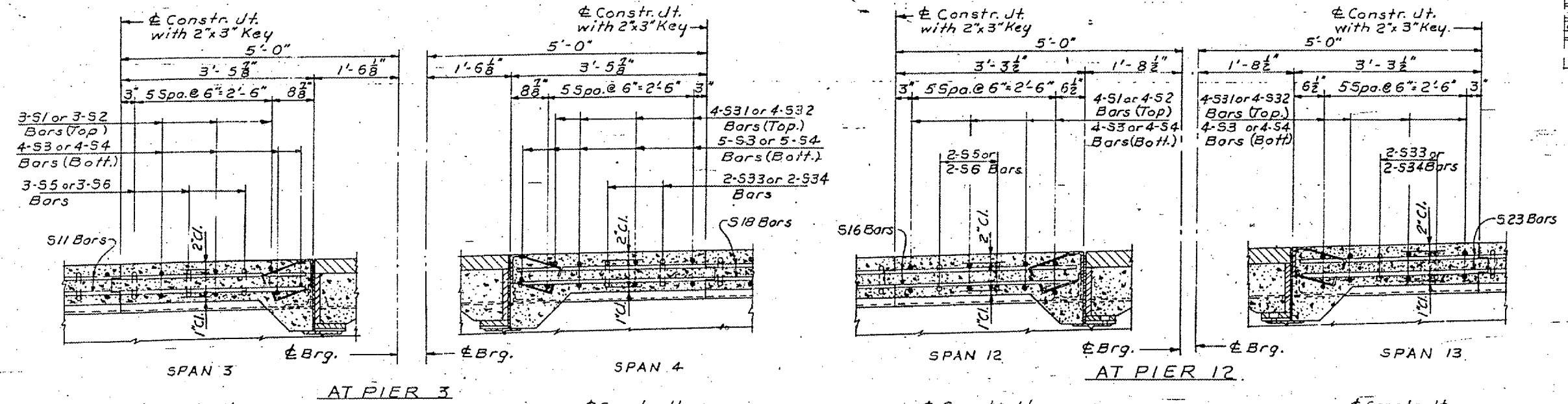
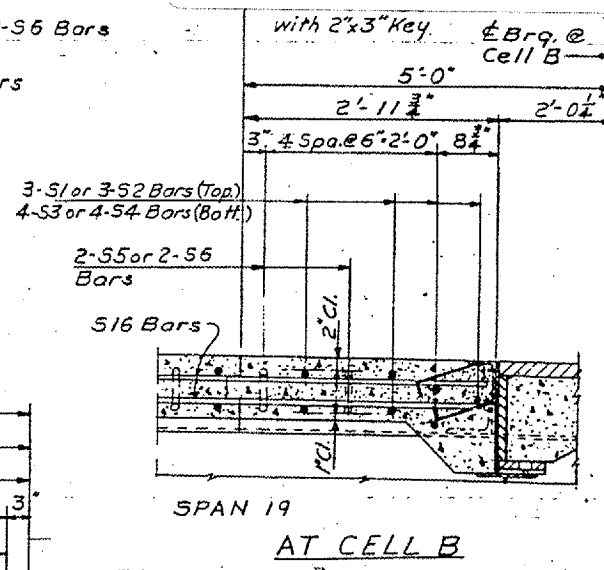
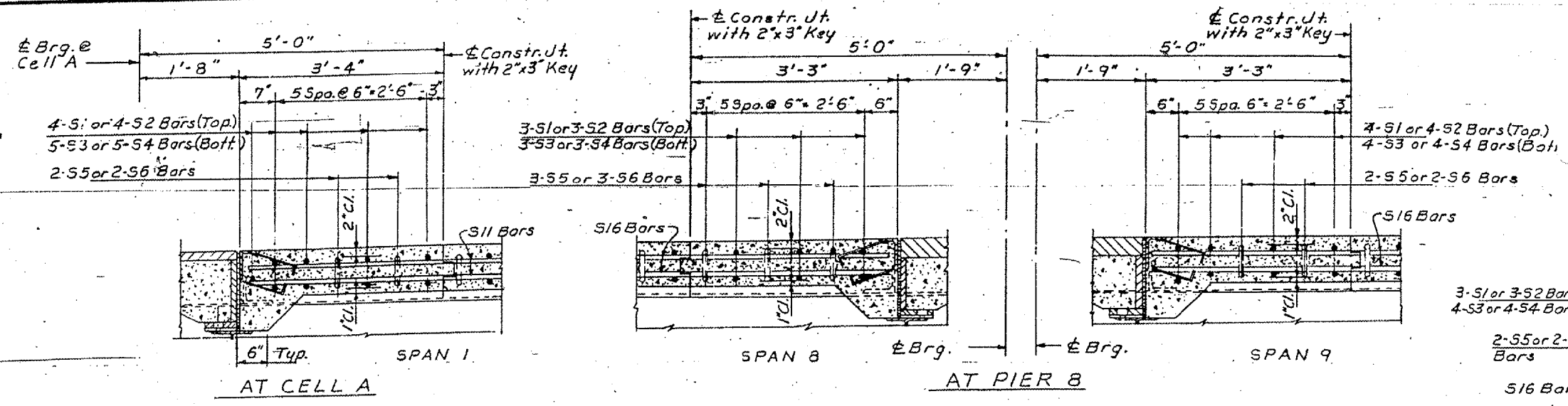

SLAB DETAILS
 SECTION D76-D76

KENTUCKY DEPARTMENT OF HIGHWAYS
 ILLINOIS DEPARTMENT OF PUBLIC WORKS
 AND BUILDINGS

PROJECTS 124-11(6)36, 124-9(1)10, 124-11(6)11
 BRIDGE OVER OHIO RIVER ON 124
 BETWEEN McCRACKEN COUNTY, KENTUCKY
 AND MASSAC COUNTY, ILLINOIS

HAZLET & BIDAL
 Consulting Engineers
 No. 828

SHEDGE
 NUMBER

DRAWING NO.
 17471

INDEX

CONTRACT: 98990
 ROUTE: INTERSTATE 24
 SECTION: (64-3B) I-6
 COUNTY: MASSAC, IL; McCRACKEN, KY
 SHEET 50 OF 99
 FOR INFORMATION ONLY

STATE OF ILLINOIS
 DEPARTMENT OF TRANSPORTATION
 DIVISION OF HIGHWAYS

PLANS FOR PROPOSED
 FEDERAL AID INTERSTATE HIGHWAY

F.A.I. ROUTE 24

SECTION 64-3B-I-2

McCRACKEN CO., KY. & MASSAC CO., ILL.
 PROJECT EACI-24-9(7)0

INDEX

Sheet No	Title
1 IA	Cover Sheet - Summary of Quantities
1B	General Notes
1C	Composite Elevation - Units I thru VII
2-4	Key Sheets - Unit II
5	Units II & V - Access to Joints thru Bolted Field Splice
6-11	Unit II Bolted Splice for Tie Girder, (incl. Sh 7a & 8a)
12	Miscellaneous Details
13-15	Key Sheets - Unit V
16-21	Unit V Bolted Splice for Tie Girder, (incl. Sh 15a & 16a)
22-24	Bolted Splice for Tie Girder with 4" Cores
25	Floorbeam - Tie Girder Connection PL & Weatherproofing @ Field Splice Jt.
26	Work to be Performed and Existing Conditions
27-28	Table of Quantities
29-32	Traffic Control Details

STANDARDS

- 2298-4
- 2299-8
- 2300-1
- 2307-4
- 2314-3
- 2315-4

24	64-3B-I-2	MASSAC	32
McCRACKEN		PROJECT EACI-24-9(7)0	

P-99-031-79

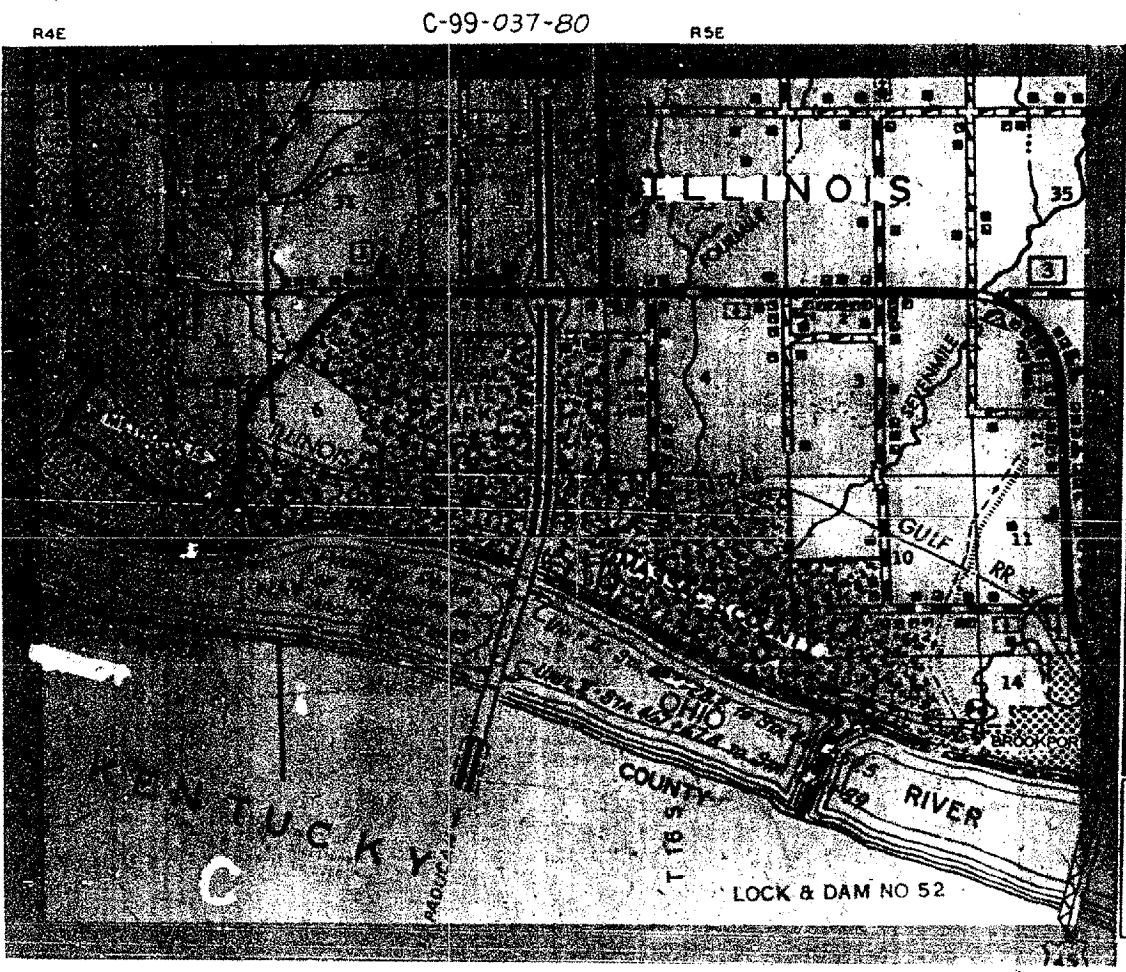
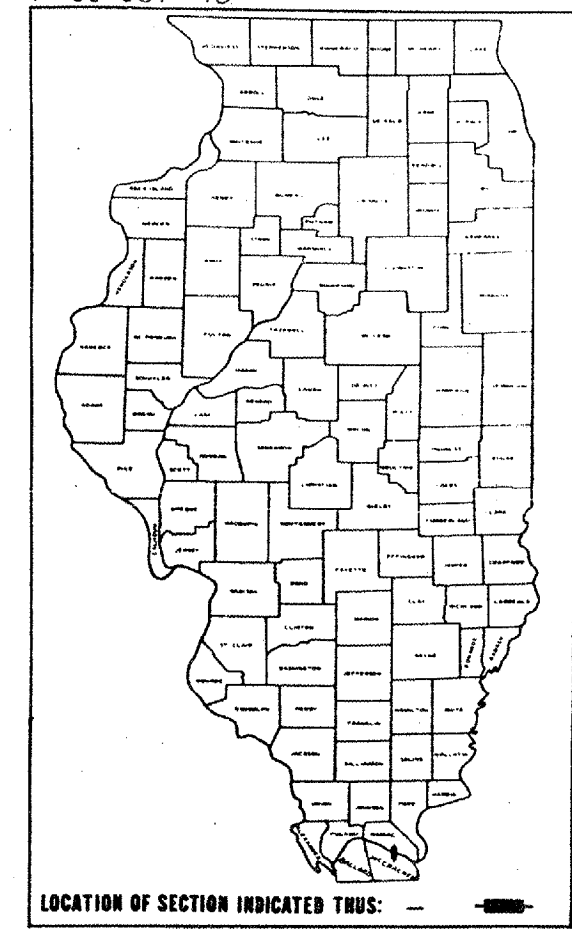

T165

KENTUCKY
 DEPARTMENT OF TRANSPORTATION
 BUREAU OF HIGHWAYS

APPROVED July 8 1980
 S.H.E. [Signature]
 STATE HIGHWAY ENGINEER

STATE OF ILLINOIS
 DEPARTMENT OF TRANSPORTATION
 DIVISION OF HIGHWAYS

EXAMINED July 9 1980
J. F. Newton
 DISTRICT ENGINEER

EXAMINED July 16 1980
[Signature]
 ENGINEER OF PLANS AND CONTRACTS

PASSED July 16 1980
Thomas R. Bright
 ENGINEER OF DESIGN

APPROVED July 16 1980
[Signature]
 DIRECTOR DIVISION OF HIGHWAYS

U.S.
 DEPARTMENT OF TRANSPORTATION
 FEDERAL HIGHWAY ADMINISTRATION

APPROVED _____
 DIVISION ADMINISTRATOR DATE

PLANS PREPARED BY
 HAZELET AND ERDAL
 CONSULTING ENGINEERS

BY [Signature]
 DATE 24 June 1980

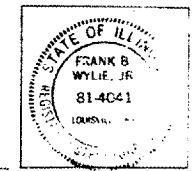

CONTRACT NO. 34626

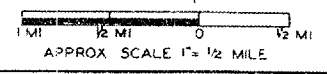

ILLINOIS DEPARTMENT OF TRANSPORTATION PROJECT EACI-24-9(7)0

24 22 MASSAC, ILL. 32 26

WORK TO BE PERFORMED DURING PHASE A
 OR PHASE B

Top Flange Splice Plate

1. Cut the floorbeam web & stiffeners as required*
2. Install the Retrofit Splice PL.

Bottom Flange Splice PL.

1. Remove the horizontal Connection PL(s) welded to edge of bottom flange.*
2. Remove "TEE" where installed under previous contract.
3. Install the Retrofit Splice PL.
4. Install new Connection PL (where required) and reconnect bottom Gusset PL of Lateral (K) Wind Bracing.*

Inside Web Splice Plate

1. Remove vertical Connection PL welded to the inside Web.*
2. Remove the top horiz. Connection PL welded to the inside Web.*
3. Install the Retrofit Splice PL.
4. Install the Bent PL connection to the floorbeam Web.*
5. Install new angles and reconnect top Gusset PL of Lateral (K) Wind bracing.*

Outside Web Splice Plate

1. Remove Gusset PL welded to outside Web.*
2. Remove "TEE" where installed under previous contract.*
3. Install the Retrofit Splice PL.

Tie Girder Support

1. Install new Retrofit "TEE".*
2. Remove temporary support.*

* Where there is an existing retrofit "Bottom Flange Splice Plate" the bottom gusset plate of the "Lateral (K) Wind bracing" has been installed. At joints which do not require a "Bottom Flange Splice Plate" all work required to install the Lateral (K) Wind Bracing (top & bottom) shall be included with the "Inside Web Splice Plate"

* This applies only at interior panel points.

Note:

All work is divided into two Phases as follows:
 Phase A - Construction to be performed prior to allowing traffic on the bridge.
 Phase B - Construction to be performed with restricted traffic on the bridge.

Ex - Retrofit Splice PL installed under previous contract.

A - New Retrofit work to be done during Phase A.

B - New Retrofit work to be done during Phase B.

Ø - No Retrofit work required.

GR - Vertical Gusset PL supporting Tie Girder welded to outside has been removed.

AH - Access Hole has been cut in top Flange.

** - Gusset PL broken and not removed.

Ø - Existing Retrofit PL to be removed.

OR - Tie Girder supported as originally erected.

T - Tie Girder supported by a "TEE" (to be removed) installed under a previous contract.

CS - Tie Girder supported by cables attached to the floorbeam.

HS - Tie Girder supported by cables attached to a H-Beam that spans from one floorbeam to the next.

WORK REQUIRED IN PHASES A & B PLUS
 EXISTING CONDITIONS OF STRUCTURE

	UNIT II						UNIT V					
	WORK TO BE PERFORMED						WORK TO BE PERFORMED					
	Top Flange	Bottom Flange	Inside Web	Outside Web	Tie Girder Support	Existing Conditions (of Tie Girder Support)	Top Flange	Bottom Flange	Inside Web	Outside Web	Tie Girder Support	Existing Conditions (of Tie Girder Support)
T0	US	A	A	A	A ^Ø		A ^Ø	A	A	A		
	DS	A	A	A	A ^Ø		A	A	A ^Ø	A		
T1	US	Ø	Ø	Ex	B	B OR	Ø	B	A	A	B OR	
	DS	Ø	Ø	B	B	B GR,T	Ø	B	B	B	B GR,T	
T2	US	Ø	B	B	B	B OR	B	Ex	B	A	A GR,H5	
	DS	Ø	Ø	A	A	A GR,CS	B	B	B	B	B OR	
T3	US	Ø	Ø	B	B	B OR,CS,AH	Ø	B	B	A	B OR,AH	
	DS	A	A	B	B	A OR	Ø	B	A	B	B OR,AH	
T4	US	Ø	Ø	B	B	B OR	Ø	Ø	B	B	B OR	
	DS	Ø	Ø	B	B	B GR,T	B	Ex	B	A	A GR,H5	
T5	US	Ex	B	B	A	B OR	Ø	Ex	B	A	A GR,H5	
	DS	Ø	Ø	A	B	B GR,CS	B	B	B	A	B OR	
T6	US	Ø	Ø	B	B	B GR,OR,AH	Ø	Ø	B	B	B OR	
	DS	B	Ø	B	B	B OR	Ø	Ø	B	B	B OR	
T7	US	Ø	Ø	A	Ex	A GR,H5	Ø	B	B	B	B OR	
	DS	Ø	Ø	Ex	A	A GR,T	Ø	Ø	B	A	A GR,T	
T8	US	Ø	Ø	B	B	B OR	Ø	B	B	B	B GR,T	
	DS	Ø	Ø	B	B	B GR,CS	A	A	B	A	A OR	
T9	US	Ø	Ø	B	B	B GR,T	Ø	Ø	B	B	B OR	
	DS	Ø	Ø	B	B	B OR,AH	Ex	Ex	Ex	A	A GR,H5	
T10	US	Ø	Ex	B	B	B **H5	Ø	B	B	A	B OR,AH	
	DS	Ex	B	A	B	B GR,T	Ø	Ø	B	A	A GR,T,AH	
T11	US	Ø	Ø	B	B	B OR,AH	Ø	Ø	Ex	B	B GR,T	
	DS	B	A	B	A	A OR	Ø	B	A	Ex	B GR,H5	
T12	US	Ø	Ø	B	B	B GR,T	Ø	Ø	A	B	B OR	
	DS	Ø	Ø	A	A	A OR	Ø	A	A	A	A OR	
T13	US	Ø	Ø	B	Ex	B GR,H5	Ø	A	Ex	B	A OR	
	DS	Ø	Ø	B	Ex	B GR,H5	B	B	A	Ex	B GR,H5	
T14	US	Ø	Ø	B	B	B OR	B	B	A	A	B GR,T	
	DS	Ø	Ø	B	B	B GR,CS,AH	Ø	Ø	B	A	A OR	
T15	US	Ø	Ø	A	A	A GR,T	Ø	A	A	A	A OR	
	DS	Ex	B	B	A	B OR	Ø	B	B	B	B OR	
T16	US	Ø	Ø	B	B	B GR,CS	B	B	B	B	B OR	
	DS	B	Ø	B	A	A GR,T	Ø	Ø	B	A	A GR,T	
T17	US	A	A	A	A		Ø	Ø	B	B	B GR,T	
	DS	A	A	A	A		B	B	B	B	B OR	
T18	US						B	A	A	A	A OR,AH	
	DS						B	A	B	A	A OR,AH	
T19	US						B	A	A	Ex	A GR,H5	
	DS						Ø	B	A	A	B GR,T	
T20	US						Ex	Ø	A	A	A GR,T	
	DS						Ø	B	A	A	B OR	
T21	US						A	A	A	A		
	DS						A	A	A	A ^Ø		

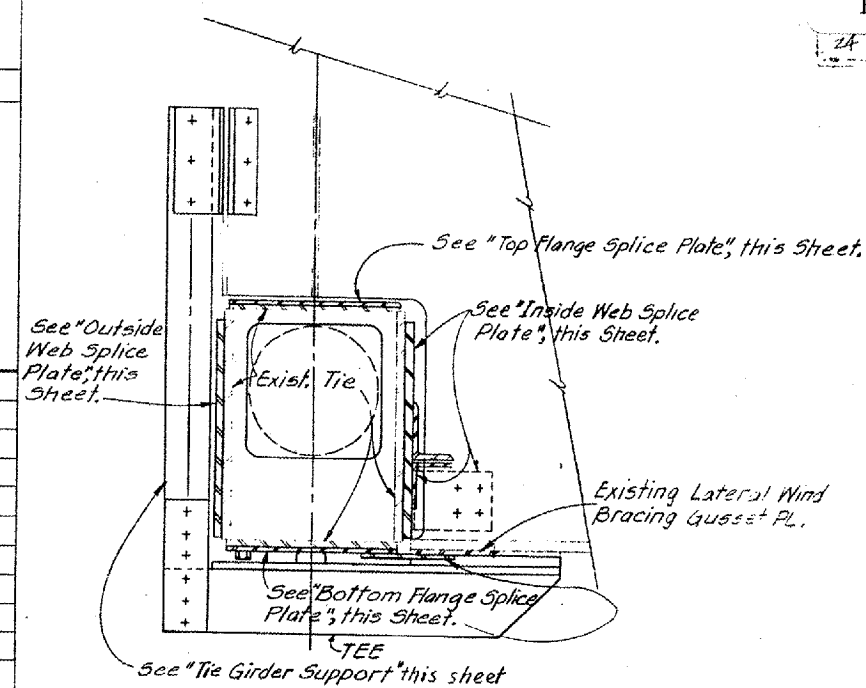

SECTION @ FLOORBEAM WITH BOTTOM FLANGE SPLICE PL
 Shown at panel point without Bolted Splice, Section at Bolted Field Splice Similar.

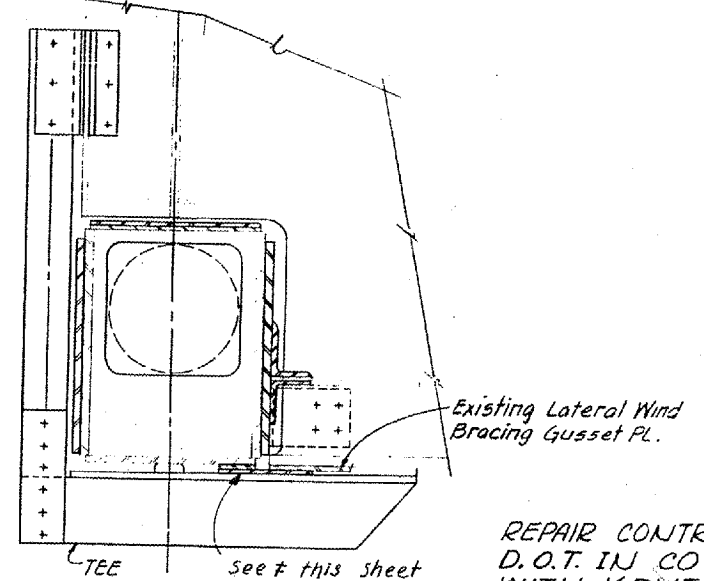

SECTION @ FLOORBEAM WITHOUT BOTTOM FLANGE SPLICE PL
 Shown at panel point without Field Bolted Splice, Section at Field Bolted Splice Similar
 (For callouts not shown, see "Section @ Floorbeam with Bottom Flange Splice Plate", above.)

REPAIR CONTRACT BY ILLINOIS D.O.T. IN CO-OPERATION WITH KENTUCKY D.O.T.
 Sheet No. 22

COMMONWEALTH OF KENTUCKY BUREAU OF HIGHWAYS ILLINOIS DEPARTMENT OF TRANSPORT.

BRIDGE OVER OHIO RIVER ON I-24 BETWEEN McCRACKEN COUNTY, KY. AND MASSAC COUNTY, ILLINOIS

WORK TO BE PERFORMED & EXISTING CONDITIONS

Revised Unit II - T9, D.S. Top Flg & Bott. Flg to Ex. (7-7-80)

UPDATE DATE
 LETTING DATE

DESIGNED BY
 CHECKED BY
 DRAWN BY
 DATE

TFR, Dec 288 #111

STATE OF ILLINOIS
DEPARTMENT OF TRANSPORTATION
DIVISION OF HIGHWAYS

CONTRACT: 98990
ROUTE: INTERSTATE 24
SECTION: (64-3B) I-6
COUNTY: MASSAC, IL; McCRACKEN, KY
SHEET 52 OF 99
FOR INFORMATION ONLY

INDEX OF DRAWINGS	
SHEET NO.	TITLE
1	TITLE SHEET
2	GENERAL ELEVATION
3	GENERAL NOTES
4	SUMMARY OF QUANTITIES
5	UNIT II - GENERAL PLAN AND ELEVATION
6	UNIT II - TRUSS DETAILS 1
7	UNIT II - TRUSS DETAILS 2
8	UNIT II - TRUSS DETAILS 3
9	UNIT II - TRUSS DETAILS 4
10	UNIT V - GENERAL PLAN AND ELEVATION
11	UNIT V - TRUSS DETAILS 1
12	UNIT V - TRUSS DETAILS 2
13	UNIT V - TRUSS DETAILS 3
14	UNIT V - TRUSS DETAILS 4
15	POST-TENSIONING DETAILS 1
16	POST-TENSIONING DETAILS 2
17	POST-TENSIONING DETAILS 3
18	FLOORBEAM RETROFIT LOCATIONS
19	RETROFIT DETAILS - 1
20	RETROFIT DETAILS - 2
21	RETROFIT DETAILS - 3
22	RETROFIT DETAILS - 4
23	ARCH TIE RETROFIT
24	UNIT II - ERECTION SEQUENCE 1
25	UNIT II - ERECTION SEQUENCE 2
26	UNIT II - ERECTION SEQUENCE 3
27	UNIT V - ERECTION SEQUENCE 1
28	UNIT V - ERECTION SEQUENCE 2
29	UNIT V - ERECTION SEQUENCE 3
30	UNIT II - MAINTENANCE AND PROTECTION OF TRAFFIC
31	UNIT V - MAINTENANCE AND PROTECTION OF TRAFFIC
32	STRESS SHEET

ALTERATIONS TO F A I 24 BRIDGE
OVER OHIO RIVER
NEAR PADUCAH, KY.

F A I ROUTE 24
PROJECT IR-024-9 (9) 38
SECTION 64-3B-I-3
MASSAC CO., IL. & McCRACKEN CO., KY.
C99-064-88

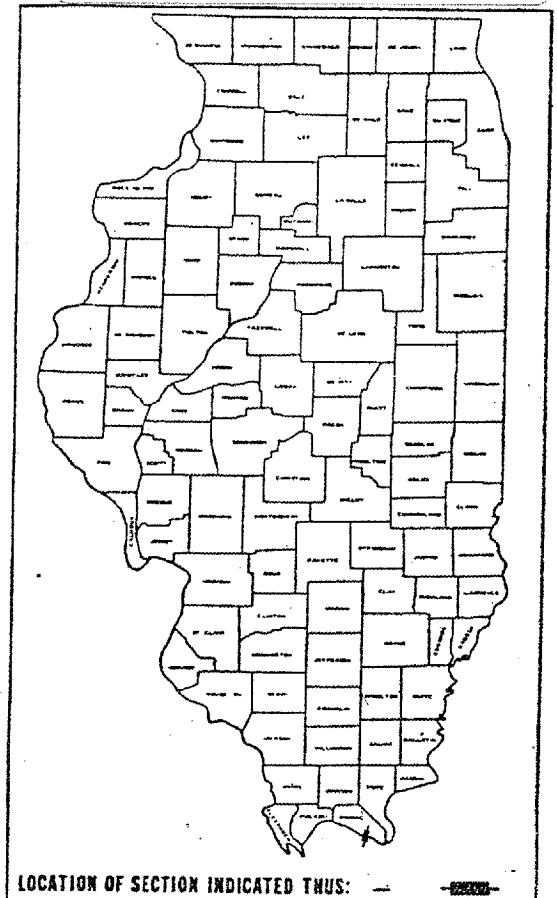

- ILLINOIS STATE STANDARDS
- 2296-7
 - 2299-10
 - 2300-3
 - 2307-6
 - 2308-4
 - 2316-11
 - 2383-1
 - 2409-1

100%
8-24-90

DIST # 9

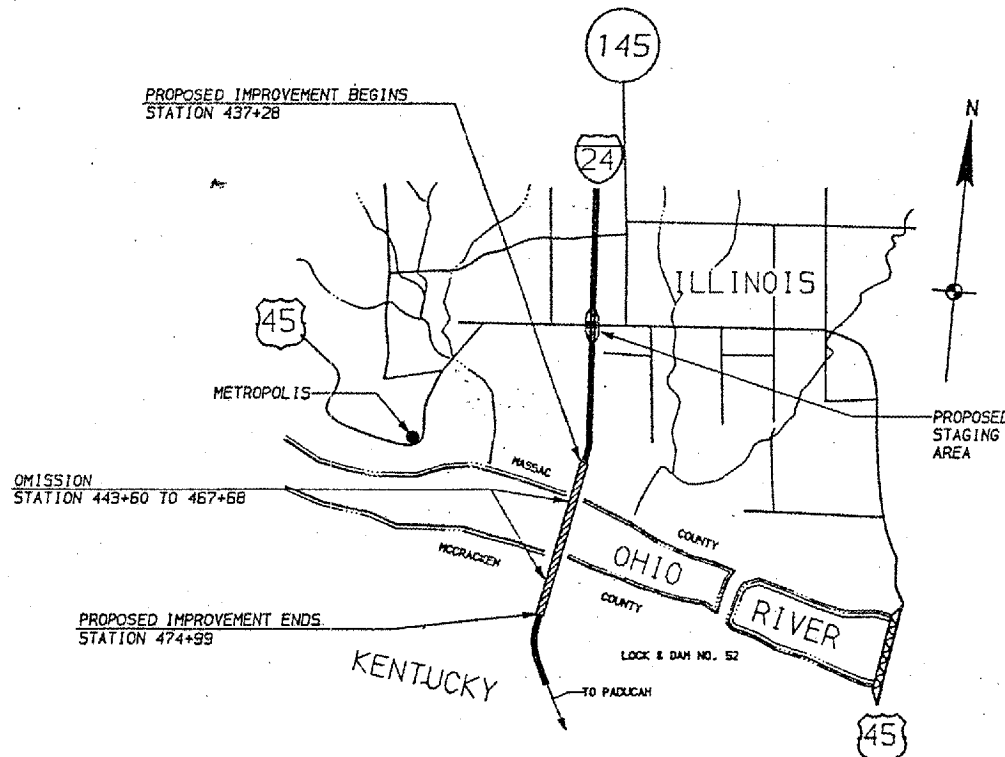

SUBMITTED BY: *John M. Kulicki*
REGISTERED CIVIL ENGINEER
ILLINOIS NO. 81-004512



PREPARED BY: MODJESKI AND MASTERS

APPROVED
FOR STRUCTURAL ADEQUACY ONLY
James J. Taylor
Engineer of Bridge Structures

CONTRACT NO. 98023

064-0035

NET LENGTH OF PROJECT = 1363 FT. = 0.258 MI.

STATE OF KENTUCKY
DEPARTMENT OF TRANSPORTATION
BUREAU OF HIGHWAYS

APPROVED _____ 19 ____
STATE HIGHWAY ENGINEER

STATE OF ILLINOIS
DEPARTMENT OF TRANSPORTATION
DIVISION OF HIGHWAYS

APPROVED: *10-12* 19 *88*
T. L. Jennings DISTRICT ENGINEER
ENGINEER
10-24 19 *88*
James D. Paul CHIEF OF FIELD AND CONTRACTS
PASSED: *10-24* 19 *88*
R. W. ... ENGINEER OF WORKS
APPROVED: *10-24* 19 *88*
Steve ... CHIEF DIVISION OF HIGHWAYS

U.S. DEPARTMENT OF TRANSPORTATION
FEDERAL HIGHWAY ADMINISTRATION

APPROVED _____
DIVISION ADMINISTRATOR DATE

REVISION 10/28/88

Revised Set 11-18-88

REEL 9-130

Bridge Rehab

CONTRACT: 98990
 ROUTE: INTERSTATE 24
 SECTION: (64-3B) I-6
 COUNTY: MASSAC, IL; McCRACKEN, KY
 SHEET 53 OF 99
 FOR INFORMATION ONLY

FAI RTE.	SECTION	NO.	32	2
24	64-3B-1-3			
ILLINOIS PROJECT				
#MASSAC, IL. & McCRACKEN, KY.				

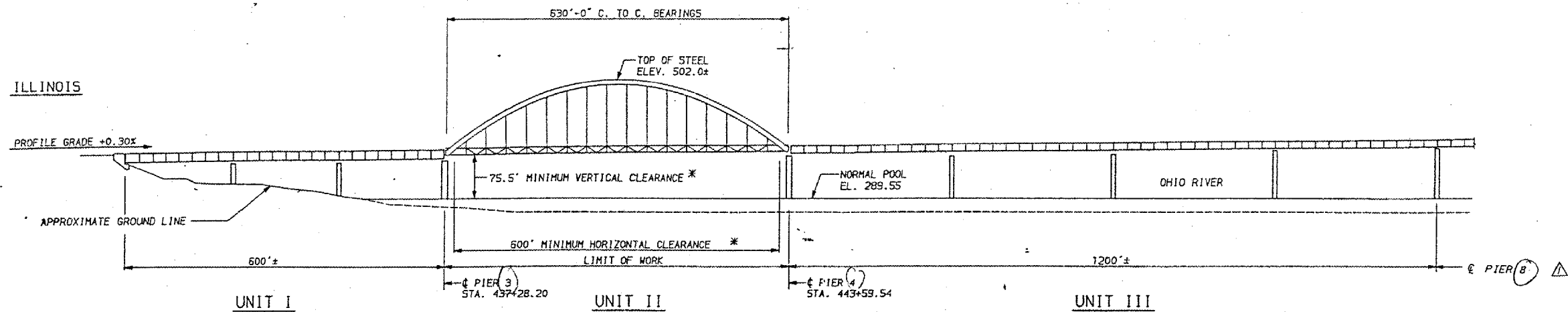

VERTICAL CURVE
 P.V.I. STA. 471+33.50
 ELEV. 402.50
 V.C. = 1400'
 M.O. = -4.90'
 +1.40% -1.40%

VERTICAL CURVE
 P.V.I. STA. 457+81.80
 ELEV. 383.576
 V.C. = 600'
 M.O. = +0.825'
 +0.30% +1.40%

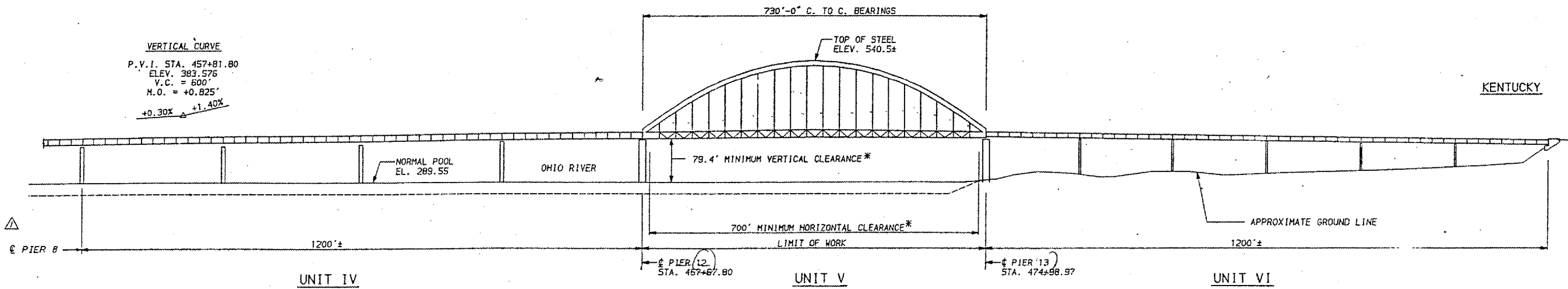

NOTES:
 * CONTRACT WILL NOT ALTER THESE
 EXISTING CLEARANCES.
 FOR GENERAL NOTES, SEE SHEET 3.

REV. NO.	DATE	DESCRIPTION	DATE

JPS REM JEP
 CHD. APPD.
 MISCELLANEOUS
 F A I ROUTE 24 (INTERSTATE 24)
 OVER OHIO RIVER
 MASSAC COUNTY ILLINOIS
 SN 064-0035
 GENERAL ELEVATION

PREPARED BY
MODJESKI AND MASTERS
 CONSULTING ENGINEERS

DRAWN: CMH, ELS
 CHKD: REM
 APPD: JEP
 DATE: 10/11/88

Revised 11-18-88

CONTRACT: 98990
 ROUTE: INTERSTATE 24
 SECTION: (64-3B)1-6
 COUNTY: MASSAC, IL; McCRACKEN, KY
 SHEET 54 OF 99
 FOR INFORMATION ONLY

FBI RTE.	SECTION	COUNTY	TOTAL SHEETS	SHEET NO.
24	64-3B-1-3	IL	32	5
ILLINOIS PROJECT				
MASSAC, IL. & McCRACKEN, KY.				

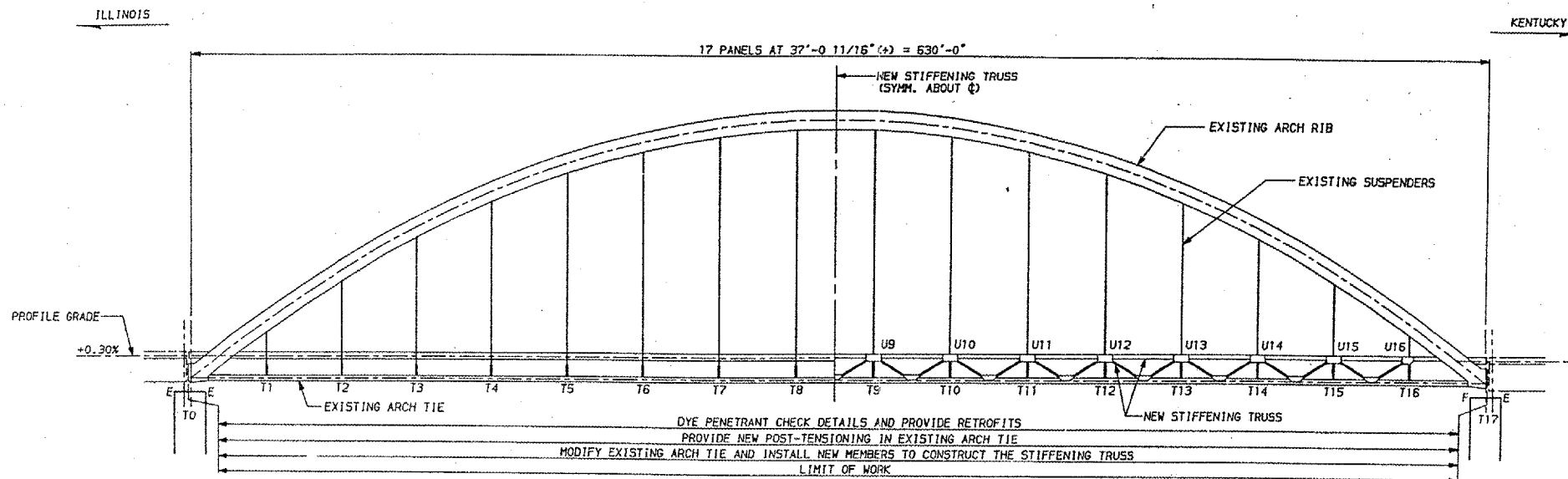

HALF ELEVATION
EXISTING

HALF ELEVATION
MODIFIED

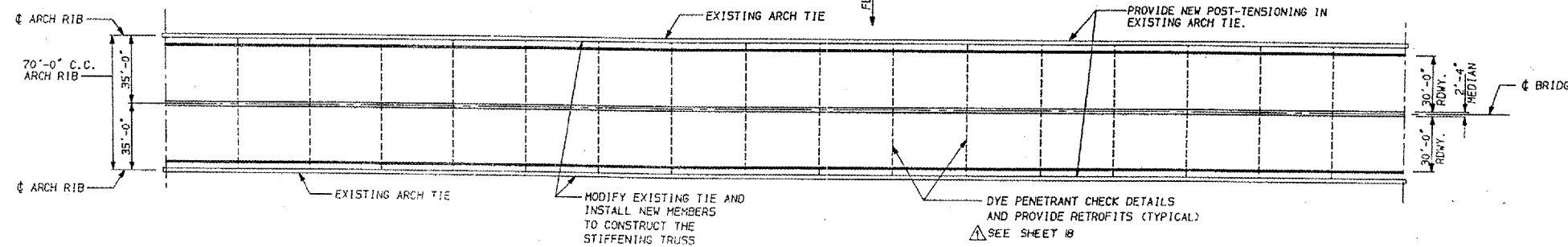

PLAN

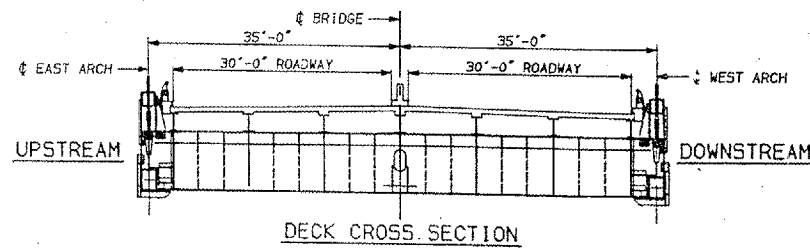

DECK CROSS SECTION

NOTE:

TWO WAY TRAFFIC WILL BE MAINTAINED AT ALL TIMES DURING CONSTRUCTION EXCEPT AS ALLOWED FOR BY THESE CONTRACT DOCUMENTS. FOR GENERAL NOTES, SEE SHEET 3. FOR MAINTENANCE AND PROTECTION OF TRAFFIC DETAILS, SEE SHEETS 30 AND 31.

REV. NO.	DATE	BY	CHKD.	APPD.	DESCRIPTION	DATE
1		JPS	REM	JEP	MISCELLANEOUS	12/26/88

F A I ROUTE 24 (INTERSTATE 24)
 OVER OHIO RIVER
 MASSAC COUNTY ILLINOIS

UNIT II
 GENERAL PLAN AND ELEVATION

Revised 1-18-89

PREPARED BY
MODJESKI AND MASTERS
 CONSULTING ENGINEERS

DRAWN: CMH, ELS
 CHKD: REM
 APPD: JEP
 DATE: 10/11/88

FAI RTE.	SECTION	#	32	5
24	64-3B-I-3			
MASSAC, IL. & McCracken, KY.				

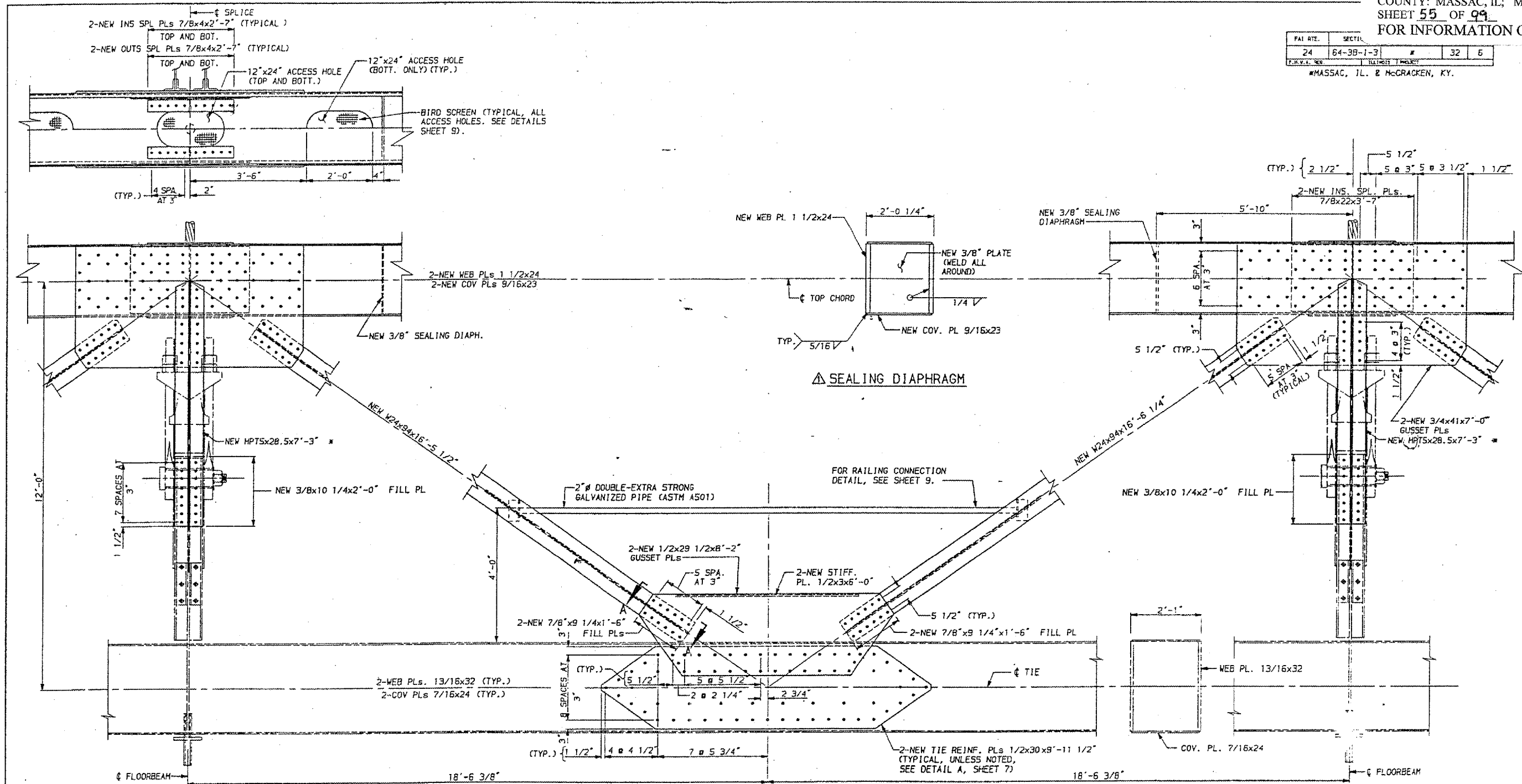

SEALING DIAPHRAGM

TYPICAL PANEL ELEVATION

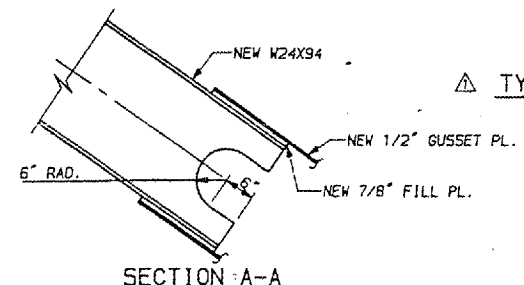

- NOTES:
- FOR GENERAL NOTES, SEE SHEET 3.
 - ♦ DENOTES EXISTING 7/8" Ø H.S. BOLT IN EXISTING HOLE.
 - * NEW VERTICAL MEMBERS SHALL BE TRULY VERTICAL.
 - DENOTES NEW 7/8" Ø H.S. BOLT (M164) IN NEW HOLE.
 - FOR SECTIONS, SEE SHEETS 7 AND 9.
 - ALL NEW STRUCTURAL STEEL SHOWN SHALL MEET NOTCH TOUGHNESS REQUIREMENTS (N.T.R.) EXCEPT 2" Ø PIPE, 3/8" SEALING DIAPHRAGM PLATE, FILL PLATES, AND STIFFENERS.

REV. NO.	DATE	BY	CHKD.	APPD.	DESCRIPTION	DATE
		SLH	REM	JEP	MISCELLANEOUS	10/24/88

F A I ROUTE 24 (INTERSTATE 24)
 OVER OHIO RIVER
 MASSAC COUNTY ILLINOIS

UNIT II
 TRUSS DETAILS - 1

Revised 11-15-88

PREPARED BY
MODJESKI AND MASTERS
 CONSULTING ENGINEERS

DRAWN: CMH, ELS
 CHKD: REM
 APPD: JEP
 DATE: 10/11/88

DATE
 10/11/88

CONTRACT: 98990
 ROUTE: INTERSTATE 24
 SECTION: (64-3B) I-6
 COUNTY: MASSAC, IL; McCracken, KY
 SHEET 57 OF 99
 FOR INFORMATION ONLY

FAI RTE.	SECT.	#	32	B
24	64-3B-1-3			
ILLINOIS PROJECT				
MASSAC, IL. & McCracken, KY.				

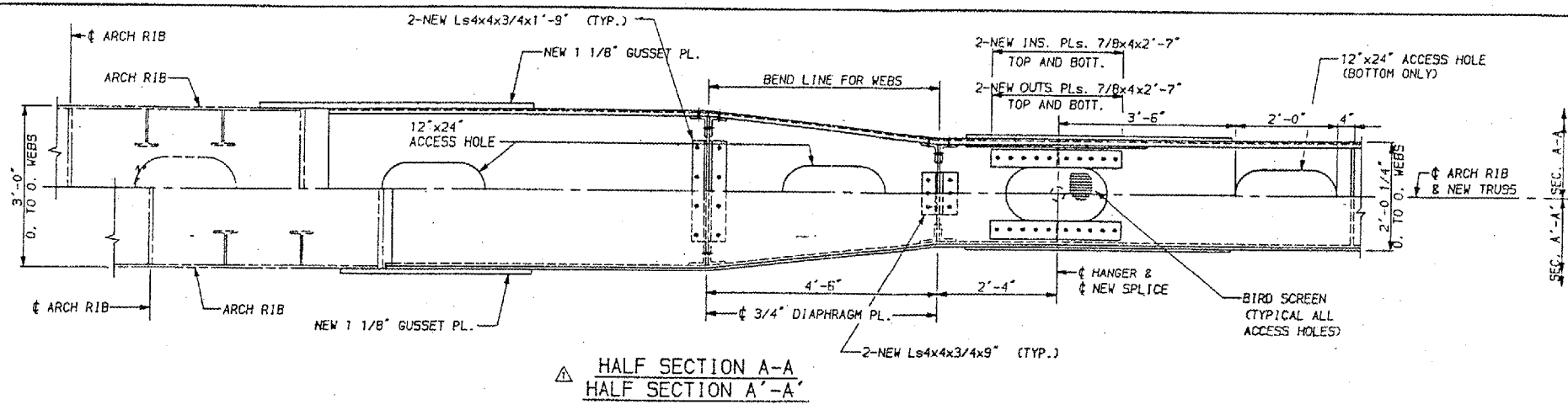

△ HALF SECTION A-A
 HALF SECTION A'-A'

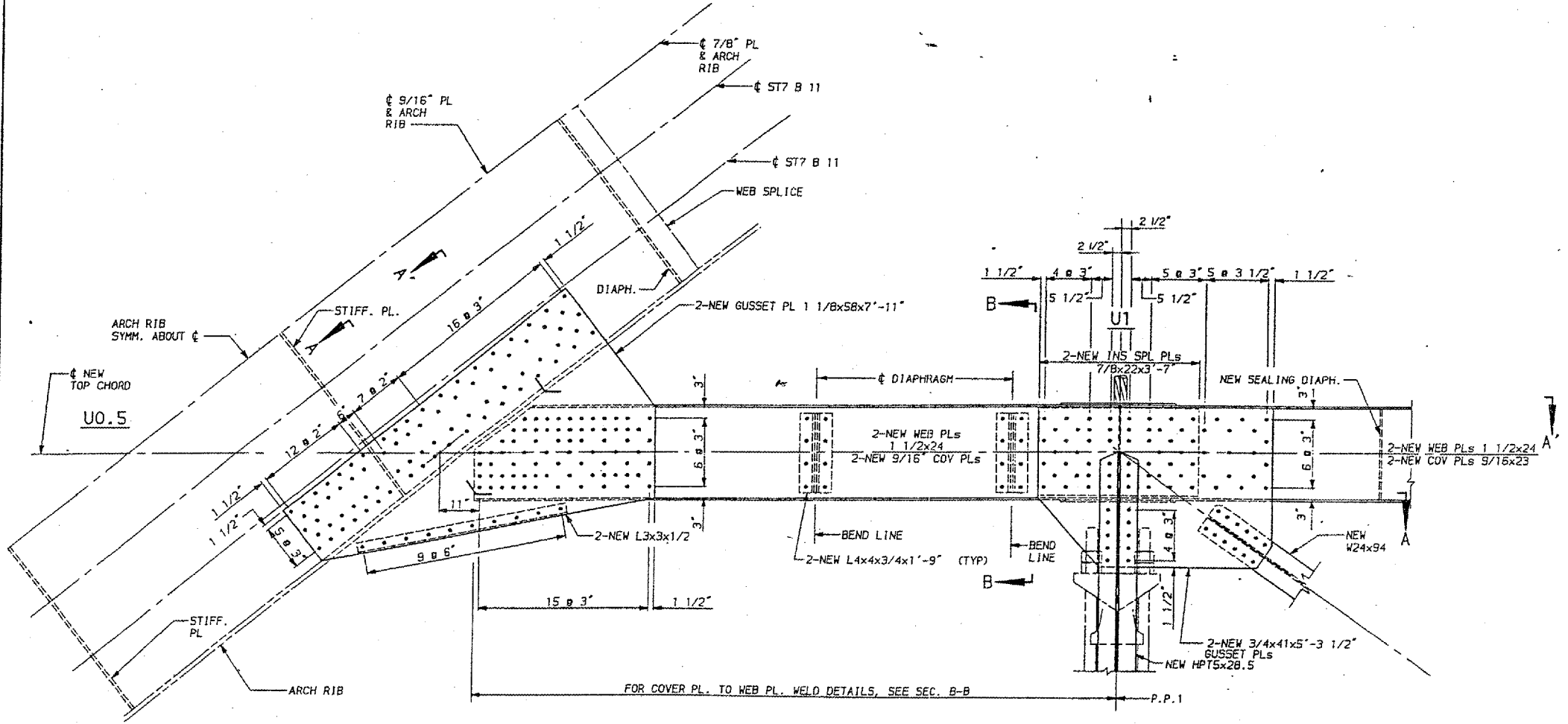

△ END PANEL ELEVATION - U0.5 TO U1

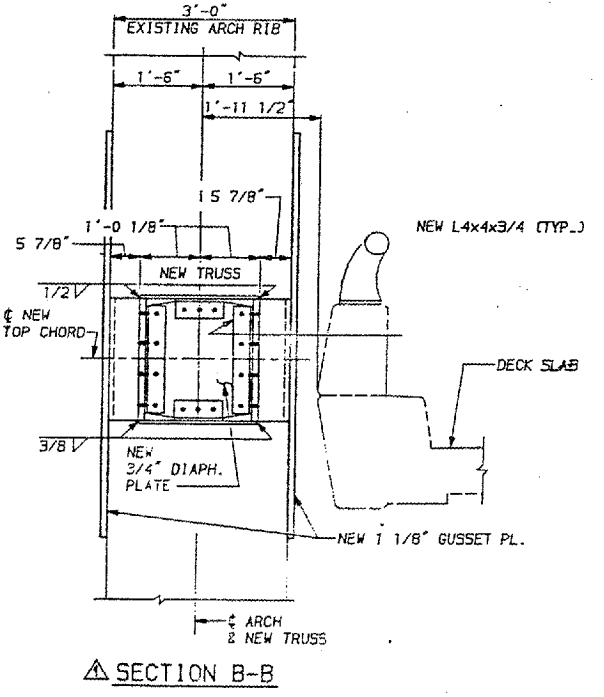

△ SECTION B-B

NOTES:
 FOR GENERAL NOTES, SEE SHEET 3.
 * INDICATES NEW 7/8" H.S. BOLT (M164)
 IN NEW HOLE.
 FOR BIRD SCREEN DETAILS, SEE SHEET 9.
 ALL NEW STRUCTURAL STEEL SHOWN SHALL MEET NOTCH TOUGHNESS REQUIREMENTS (N.T.R.) EXCEPT L4x4x3/4, L3x3x1/2, AND 3/4" DIAPHRAGM PLATE.

PREPARED BY
MODJESKI AND MASTERS
 CONSULTING ENGINEERS

DRAWN: SLH, CMH, DTP
 CKD: REM
 APPD: JEP
 DATE: 10/11/88

SLH	REM	JEP	MISCELLANEOUS	10/27/88
REV. NO.	DRAWN	CHKD.	APPD.	DATE
F A I ROUTE 24 (INTERSTATE 24) OVER OHIO RIVER MASSAC COUNTY ILLINOIS				
UNIT II TRUSS DETAILS - 3				

24	64-3B-1-3	32	9
ILL. V.A. RES.	ILLINOIS PROJECT		

MASSAC, IL. & McCRACKEN, KY.

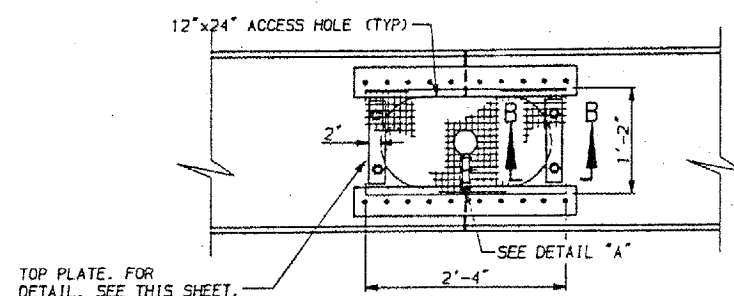

△ BIRD SCREEN DETAIL

NOTE: BIRD SCREENS SHALL BE INSTALLED AFTER STRUCTURAL BOLTING IS COMPLETED.

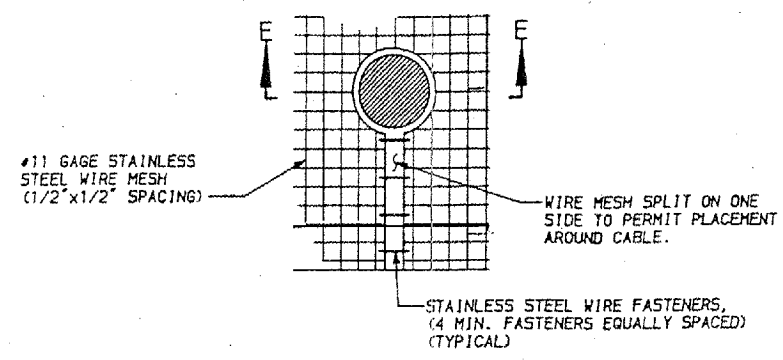

DETAIL A

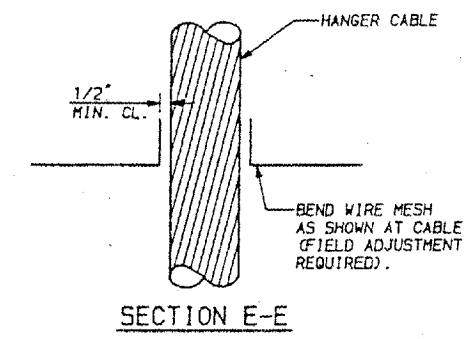

SECTION E-E

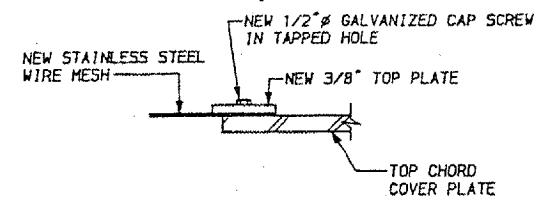

△ SECTION B-B

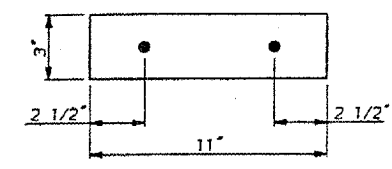

△ 3/8" TOP PLATE DETAIL

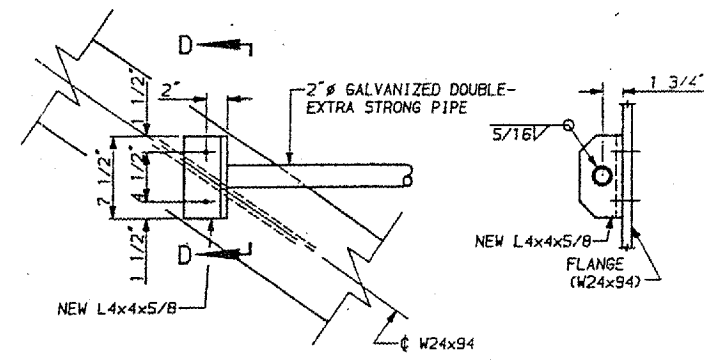

RAIL DETAIL
(INTERIOR FACE OF STIFFENING TRUSS SHOWN)

SECTION D-D

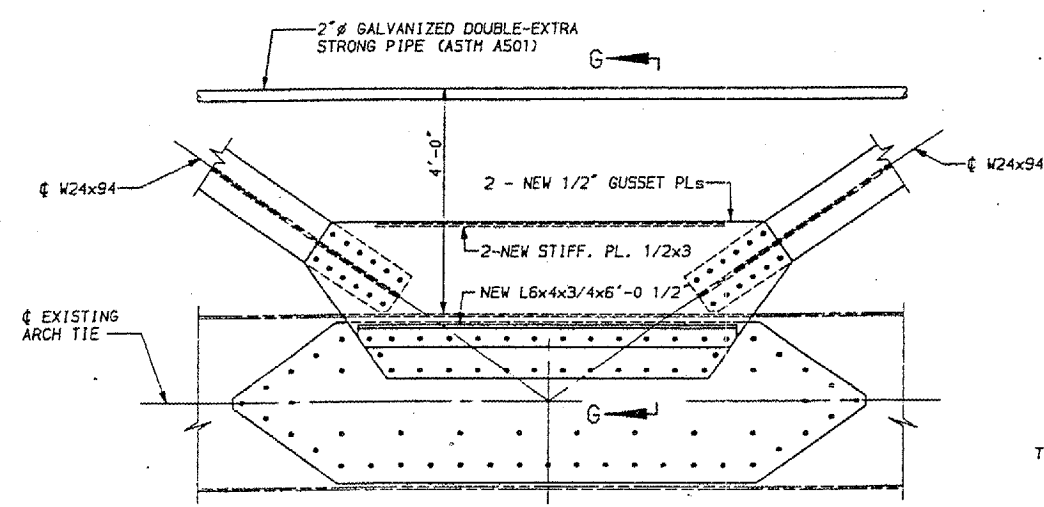

△ TYPICAL DETAIL AT DIAGONAL/TIE CONNECTION
(INTERIOR FACE OF STIFFENING TRUSS SHOWN)

NOTE: FOR BOLT SPACING NOT SHOWN, SEE SHEET 6.

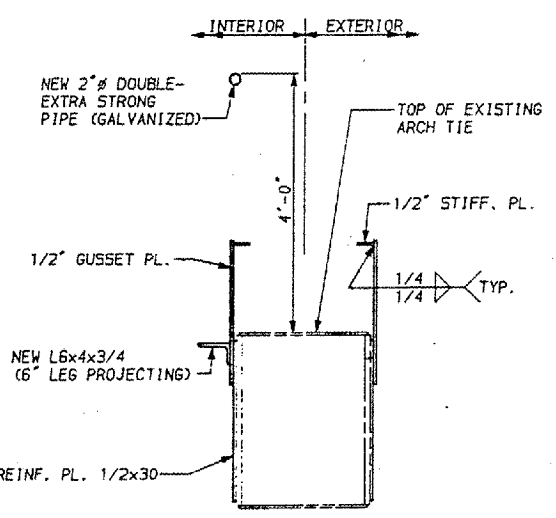

△ SECTION G-G

NOTES:
 FOR GENERAL NOTES, SEE SHEET 3.
 △ DENOTES NEW 7/8" H.S. BOLT (M164) IN NEW HOLE.

PREPARED BY
MODJESKI AND MASTERS
 CONSULTING ENGINEERS

DRAWN: DTP
 CHKD: REH
 APPD: JEP

DATE: 10/11/88

REV. NO.	DRAWN	CHKD.	APPO.	DESCRIPTION	DATE
△	SLH	REN	JEP	MISCELLANEOUS	10/27/88

**F A I ROUTE 24 (INTERSTATE 24)
 OVER OHIO RIVER
 MASSAC COUNTY ILLINOIS**

**UNIT II
 TRUSS DETAILS - 4**

CONTRACT: 98990
 ROUTE: INTERSTATE 24
 SECTION: (64-3B) I-6
 COUNTY: MASSAC, IL; McCracken, KY
 SHEET 59 OF 99
 FOR INFORMATION ONLY

24	64-3B-1-3	32	10
----	-----------	----	----

ILLINOIS PROJECT
 MASSAC, IL. & McCracken, KY.

P.V.I. STA. 471+33.50
 ELEV. 402.50
 V.C. = 1400.00'

+1.40X -1.40X

ILLINOIS

KENTUCKY

21 PANELS AT 34'-9 1/8" = 730'-0"

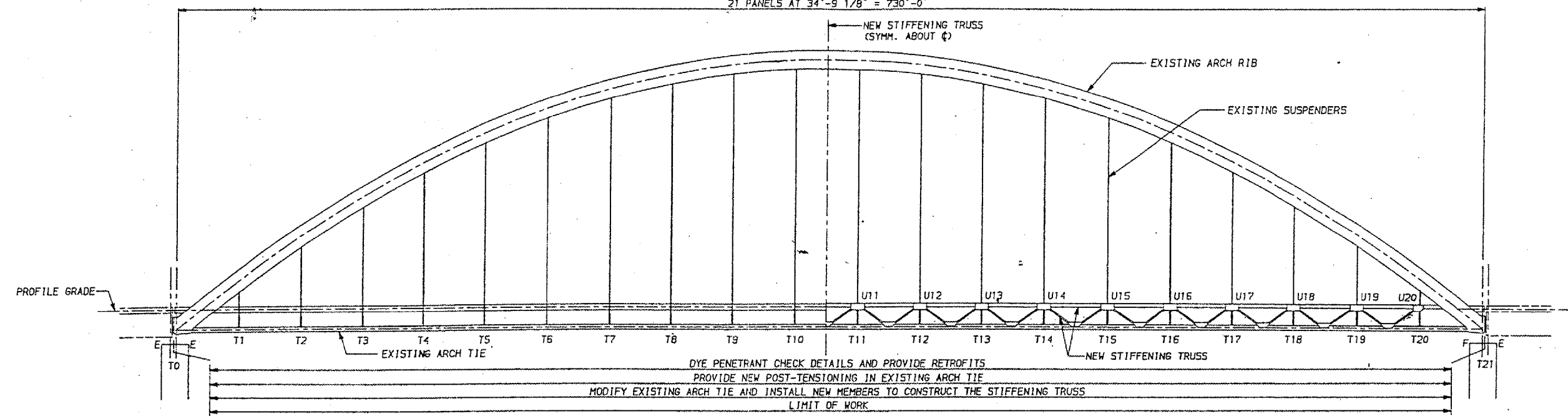

HALF ELEVATION
EXISTING

HALF ELEVATION
MODIFIED

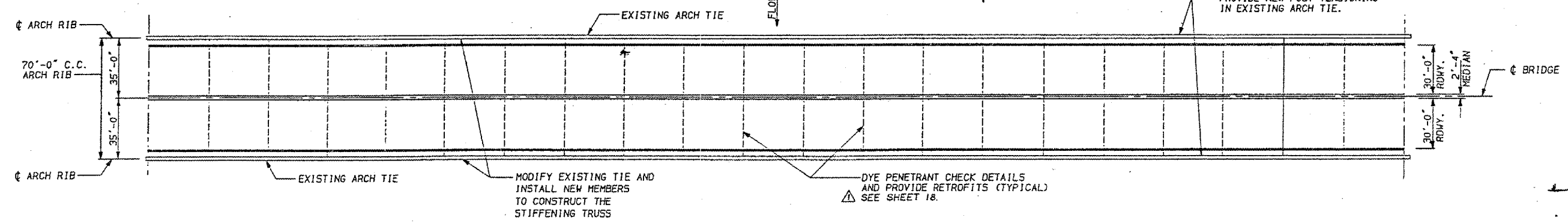

PLAN

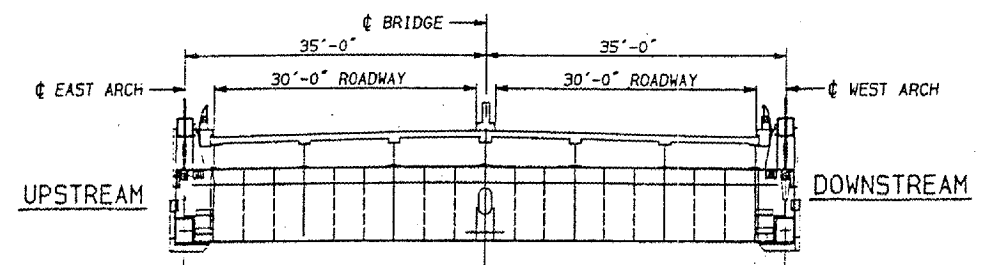

DECK CROSS SECTION

NOTE:
 TWO WAY TRAFFIC WILL BE MAINTAINED AT ALL TIMES DURING CONSTRUCTION EXCEPT AS ALLOWED FOR BY THESE CONTRACT DOCUMENTS. FOR GENERAL NOTES, SEE SHEET 3. FOR MAINTENANCE AND PROTECTION OF TRAFFIC DETAILS, SEE SHEETS 30 AND 31.

REV. NO.	DRAWN	CHKD.	APPD.	DESCRIPTION	DATE
	SLM	REM	JEP	MISCELLANEOUS	11/2/88

F A I ROUTE 24 (INTERSTATE 24)
 OVER OHIO RIVER
 MASSAC COUNTY ILLINOIS

UNIT V
 GENERAL PLAN AND ELEVATION

PREPARED BY
MODJESKI AND MASTERS
 CONSULTING ENGINEERS

DRAWN: CMH, ELS
 CHKD: REM
 APPD: JEP
 DATE: 10/11/88

Revised 11/15/88

CONTRACT: 98990
 ROUTE: INTERSTATE 24
 SECTION: (64-3B) I-6
 COUNTY: MASSAC, IL; McCRACKEN, KY
 SHEET 60 OF 99
 FOR INFORMATION ONLY

24	64-3B-I-3	32	11
ILLINOIS PROJECT		#MASSAC, IL. & McCRACKEN, KY.	

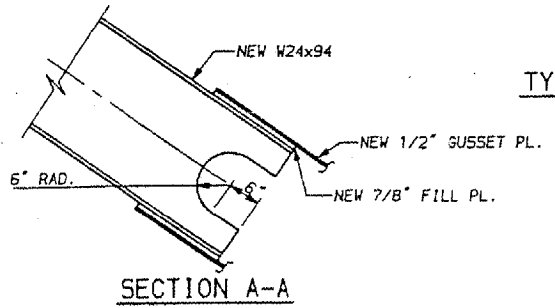
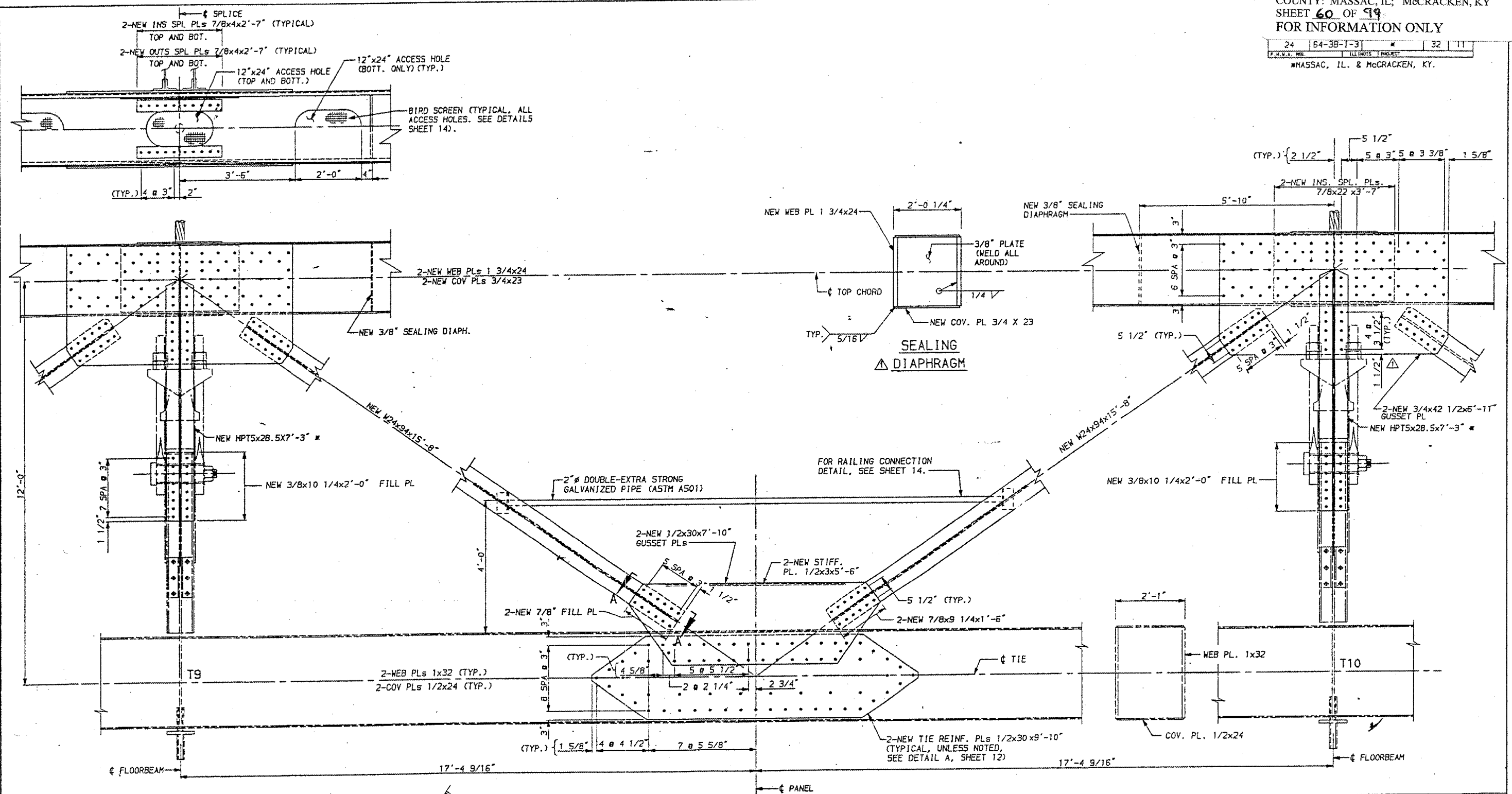

TYPICAL PANEL ELEVATION
 (T9-T10 SHOWN)

NOTES:
 FOR GENERAL NOTES, SEE SHEET 3.
 ♦ DENOTES EXISTING 7/8\"/>

PREPARED BY
MODJESKI AND MASTERS
 CONSULTING ENGINEERS
 DRAWN: CMH,ELS
 CHD, REH
 APPD, JEP
 DATE: 10/11/98

REV. NO	DATE	BY	CHKD.	APPD.	DESCRIPTION	DATE
1	10/25/98	SLH	REH	JEP	MISCELLANEOUS	10/25/98

F A I ROUTE 24 (INTERSTATE 24)
 OVER OHIO RIVER
 MASSAC COUNTY ILLINOIS

UNIT V
 TRUSS DETAILS - 1

Revised 11-15-98

24	64-3B-1-3	32	12
F.R.V.A. NO.	ILLINOIS PROJECT		
MASSAC, IL. & McCRACKEN, KY.			

NOTE: FOR BOLT SPACING NOT SHOWN, SEE TYPICAL DETAIL SHEET 11.

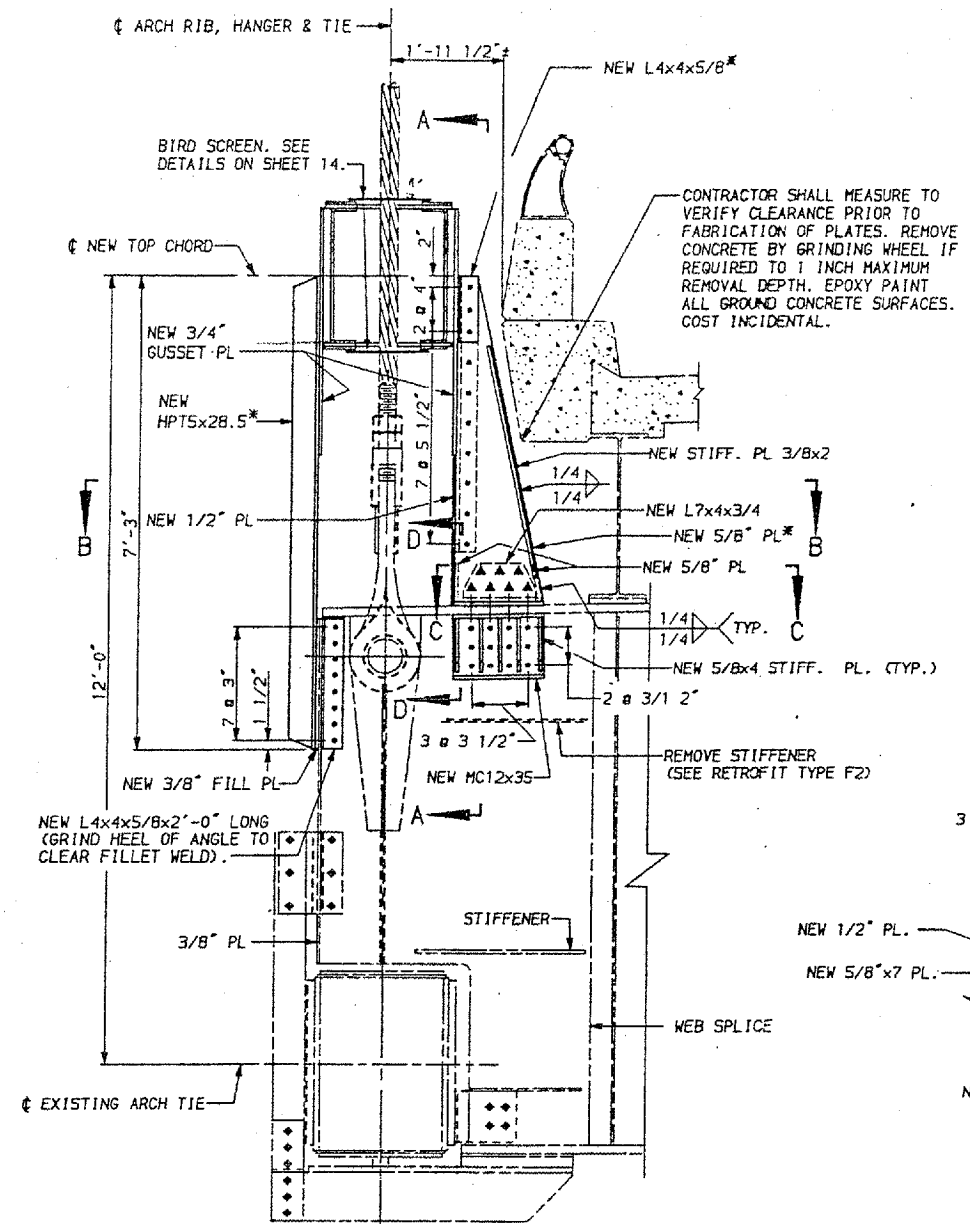

△ TYPICAL SECTION AT FLOORBEAM (T9 SHOWN)

♦ DENOTES EXISTING 7/8" H.S. BOLT IN EXISTING HOLE.

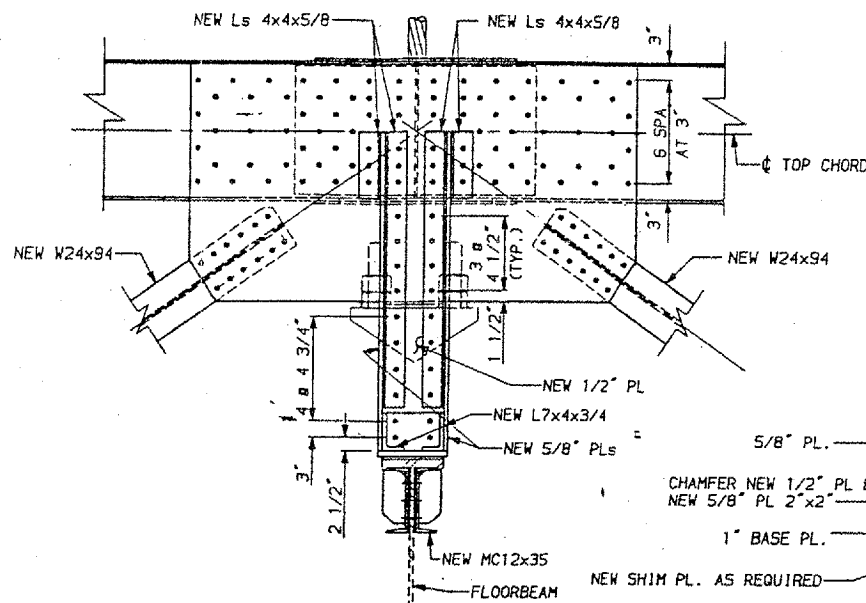

△ SECTION A-A

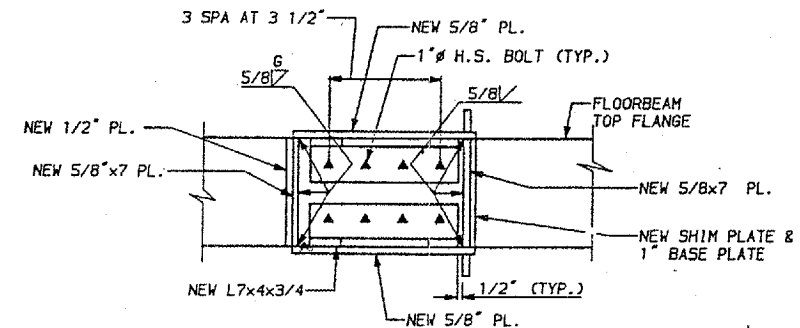

△ SECTION C-C

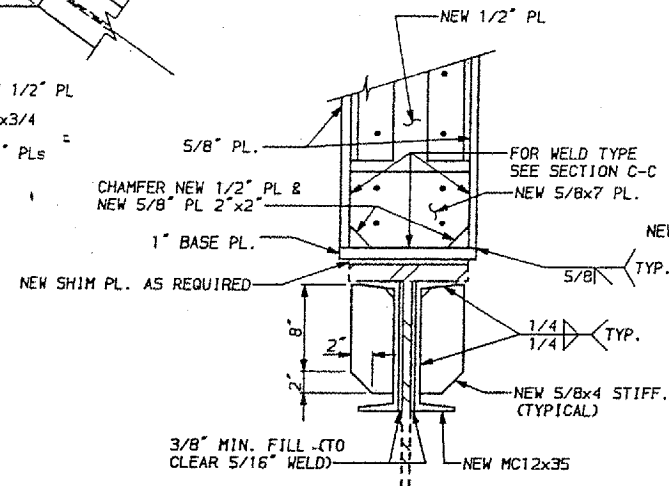

△ SECTION D-D

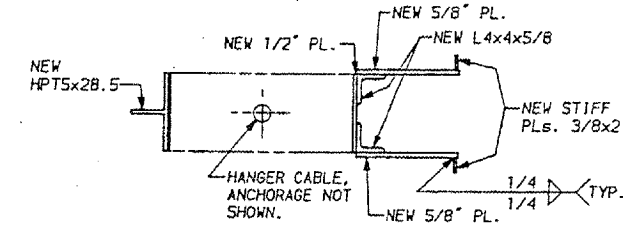

SECTION B-B

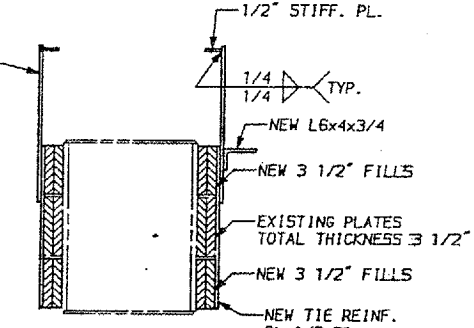

△ SECTION F-F

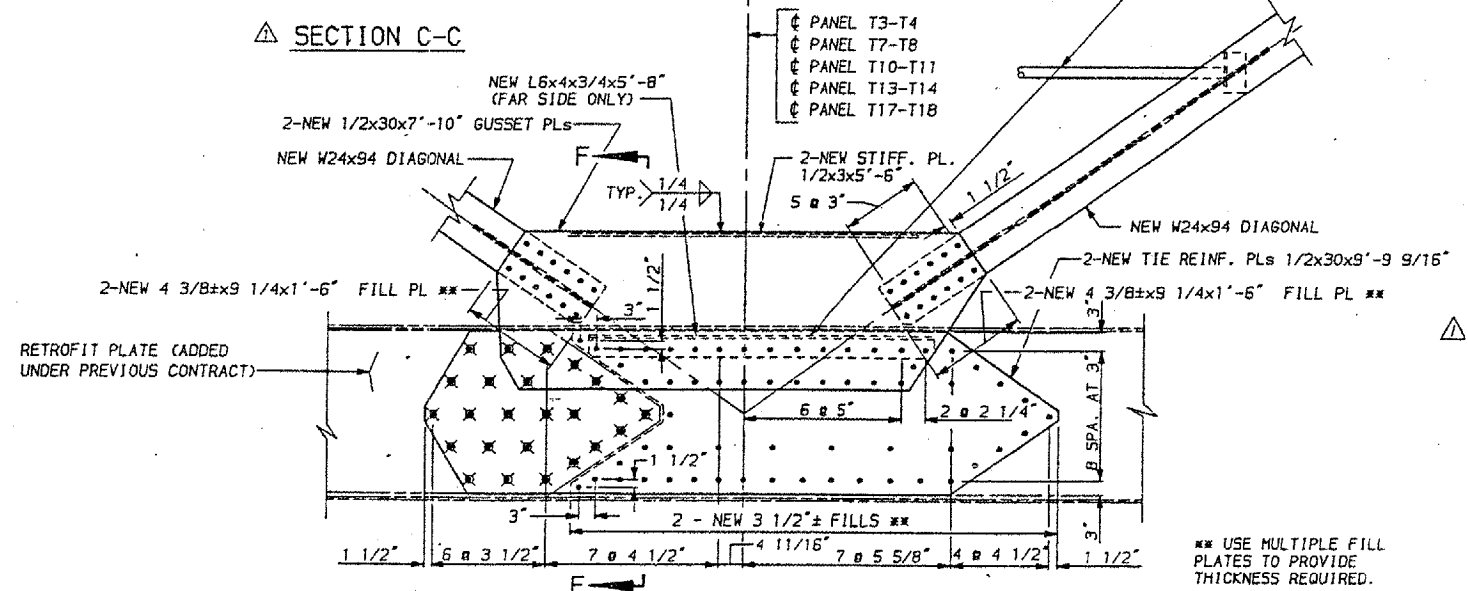

△ DETAIL AT DIAGONAL/TIE CONNECTION

PANEL T10-T11 (WEST ARCH SHOWN) FOR TYPICAL DETAILS SEE SHEETS 11 & 14

** USE MULTIPLE FILL PLATES TO PROVIDE THICKNESS REQUIRED.

- NOTES:
- FOR GENERAL NOTES, SEE SHEET 3.
 - ♦ DENOTES NEW 1 1/4" H.S. BOLT (AASHTO M 253) IN EXISTING HOLE.
 - DENOTES NEW 7/8" H.S. BOLT IN NEW HOLE.
 - * VERTICAL MEMBERS SHALL BE FULLY VERTICAL.
 - FOR RETROFIT TYPE F2, SEE SHEET 19.
 - ▲ DENOTES NEW 1" H.S. BOLT (AASHTO M 154) IN NEW HOLE.
 - ALL NEW STRUCTURAL STEEL SHOWING SHALL MEET NOTCH TOUGHNESS REQUIREMENTS (N.T.R.) EXCEPT RAIL, STIFFENERS AND ANGLE SHOWN ON DETAIL AT DIAGONAL/TIE CONNECTION.

SLH	REM	JEP	MISCELLANEOUS	10/28/88
REV. NO.	DRAWN	CHKD.	APPD.	DATE

F A I ROUTE 24 (INTERSTATE 24)
 OVER OHIO RIVER
 MASSAC COUNTY ILLINOIS

UNIT V
 TRUSS DETAILS - 2

PREPARED BY
MODJESKI AND MASTERS
 CONSULTING ENGINEERS

DATE: 10/11/88

CONTRACT: 98990
 ROUTE: INTERSTATE 24
 SECTION: (64-3B) I-6
 COUNTY: MASSAC, IL; McCRACKEN, KY
 SHEET 62 OF 99
 FOR INFORMATION ONLY

24	64-3B-1-3	32	13
P.N.Y.A. REV.	ILLINOIS PROJECT		
MASSAC, IL. & McCRACKEN, KY.			

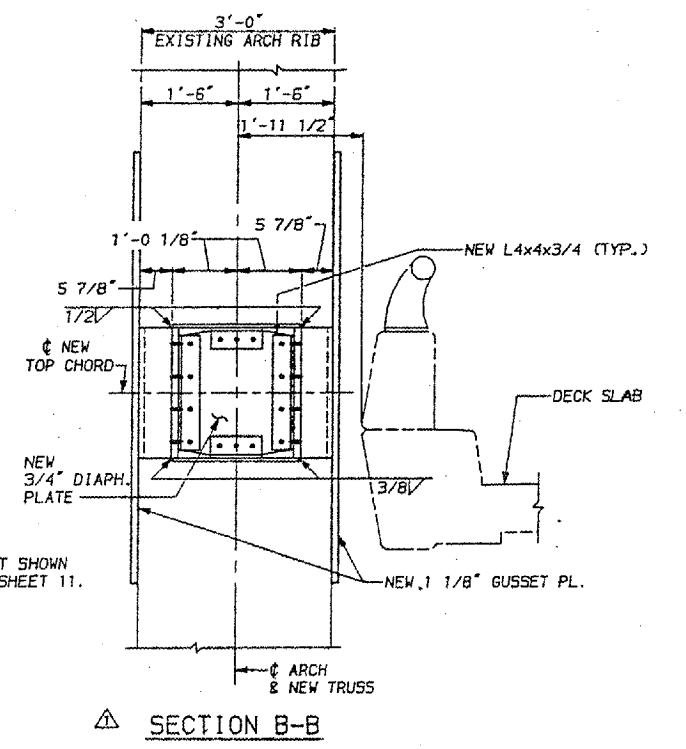
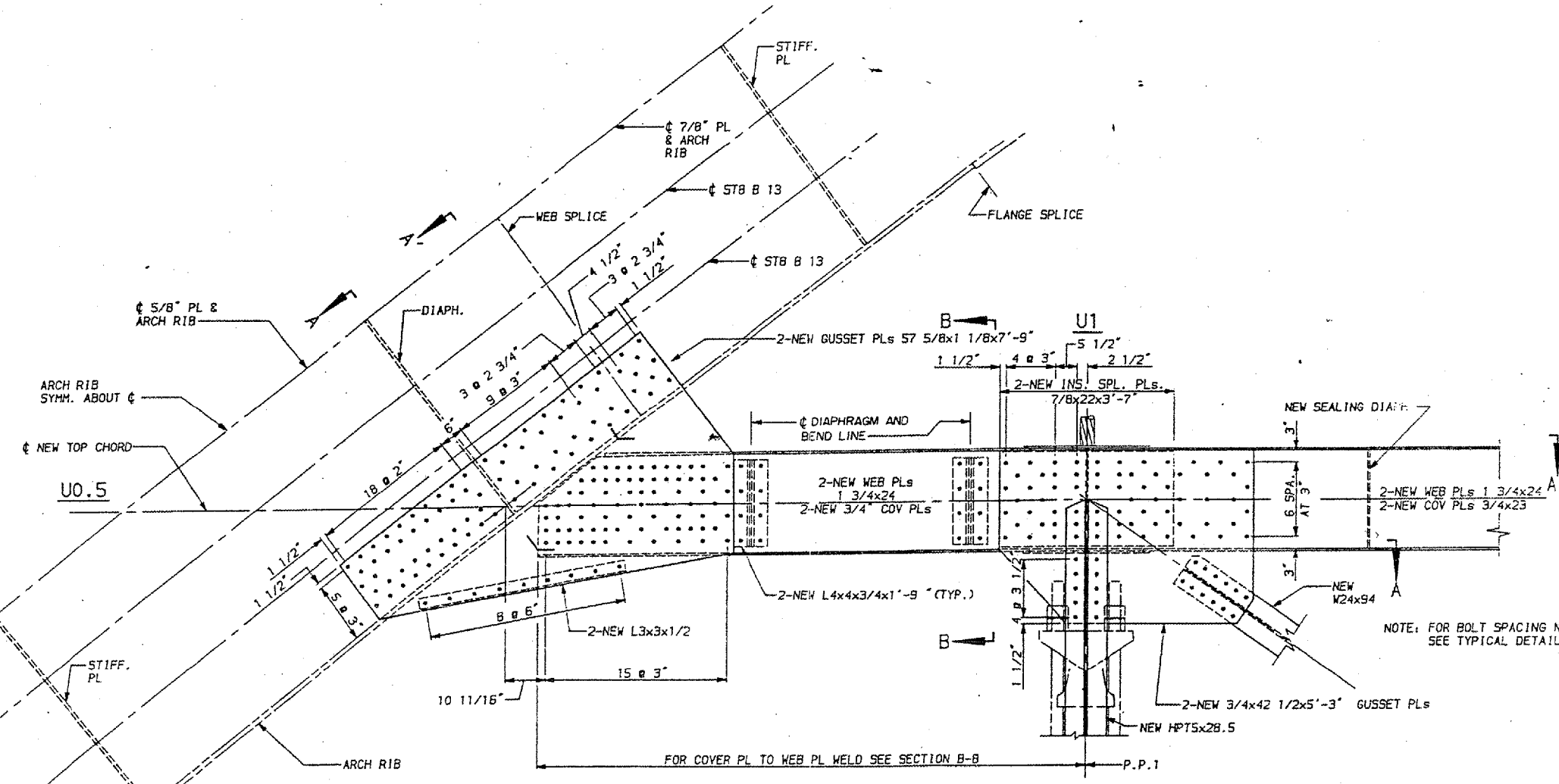
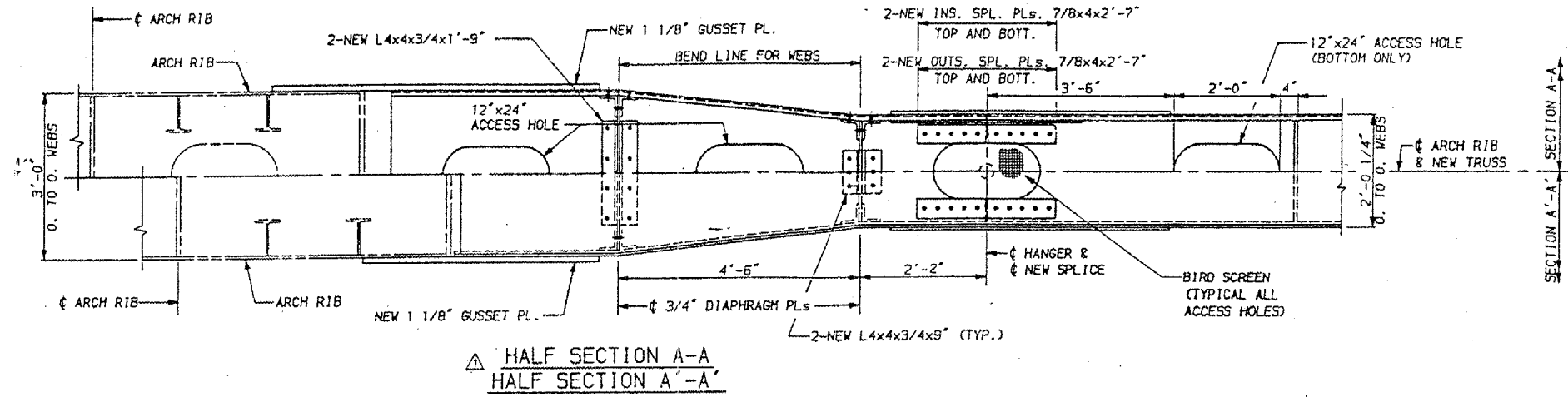

△ END PANEL ELEVATION - U0.5 TO U1

NOTES:
 FOR GENERAL NOTES, SEE SHEET 3.
 • INDICATES NEW 7/8" H.S. BOLT (M164) IN NEW HOLE.
 FOR BIRD SCREEN DETAILS, SEE SHEET 14.
 ALL NEW STRUCTURAL STEEL SHALL MEET NOTCH TOUGHNESS REQUIREMENTS (N.T.R.) EXCEPT L4x4x3/4, L3x3x1/2 AND 3/4" DIAPHRAGM PLATE.

REV. NO.	SLH	REM	JEP	DESCRIPTION	DATE
1				MISCELLANEOUS	10/28/88
F A I ROUTE 24 (INTERSTATE 24) OVER OHIO RIVER MASSAC COUNTY ILLINOIS					
UNIT V TRUSS DETAILS - 3					

PREPARED BY
MODJESKI AND MASTERS
 CONSULTING ENGINEERS

DATE: 10/11/88

24	64-38-1-3	*	32	14
ILLINOIS PROJECT		ILLINOIS PROJECT		
*MASSAC. IL. & McCRACKEN, KY.				

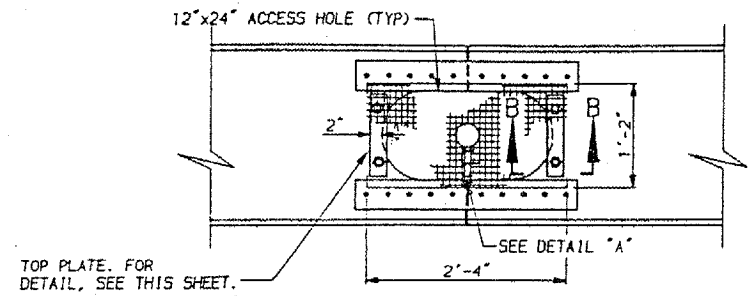

△ BIRD SCREEN DETAIL

NOTE: BIRD SCREENS SHALL BE INSTALLED AFTER STRUCTURAL BOLTING IS COMPLETED.

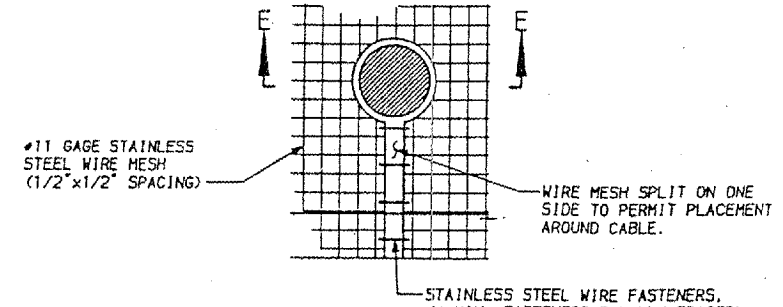

DETAIL A

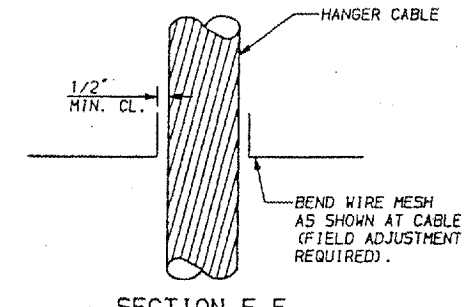

SECTION E-E

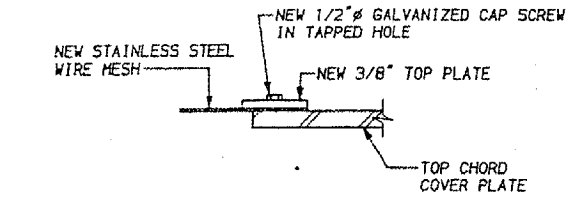

△ SECTION B-B

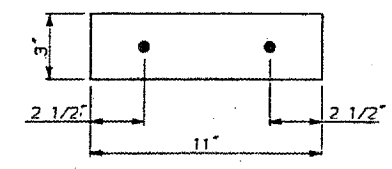

△ 3/8" TOP PLATE DETAIL

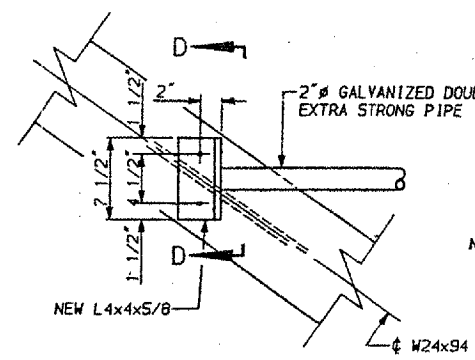

RAIL DETAIL
(INTERIOR FACE OF STIFFENING TRUSS SHOWN)

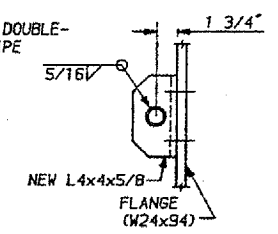

SECTION D-D

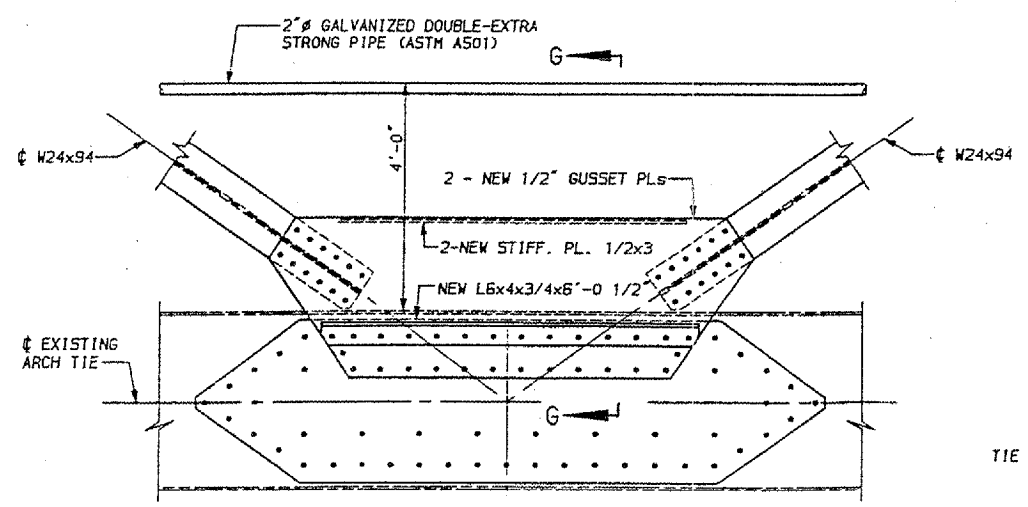

△ TYPICAL DETAIL AT DIAGONAL/TIE CONNECTION
(INTERIOR FACE OF STIFFENING TRUSS SHOWN)

NOTE: FOR BOLT SPACING NOT SHOWN SEE SHEET 11.

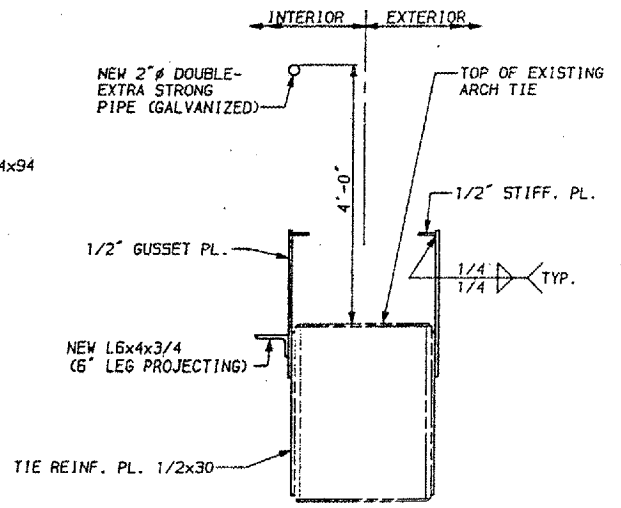

△ SECTION G-G

NOTES:
 △ FOR GENERAL NOTES, SEE SHEET 3.
 • DENOTES NEW 7/8" H.S. BOLT (M164) IN NEW HOLE.

PREPARED BY
MODJESKI AND MASTERS
 CONSULTING ENGINEERS

DRAWN, DTP
 CHKD, REM
 APPD, JEP
 DATE: 10/11/88

REV. NO.	DATE	BY	CHKD.	APPD.	DESCRIPTION	DATE

**F A I ROUTE 24 (INTERSTATE 24)
 OVER OHIO RIVER
 MASSAC COUNTY ILLINOIS**

**UNIT V
 TRUSS DETAILS - 4**

24	64-3B-1-3	M	32	15
F.R.V.A. RES.		ILLINOIS PROJECT		
*MASSAC, IL. & McCRACKEN, KY.				

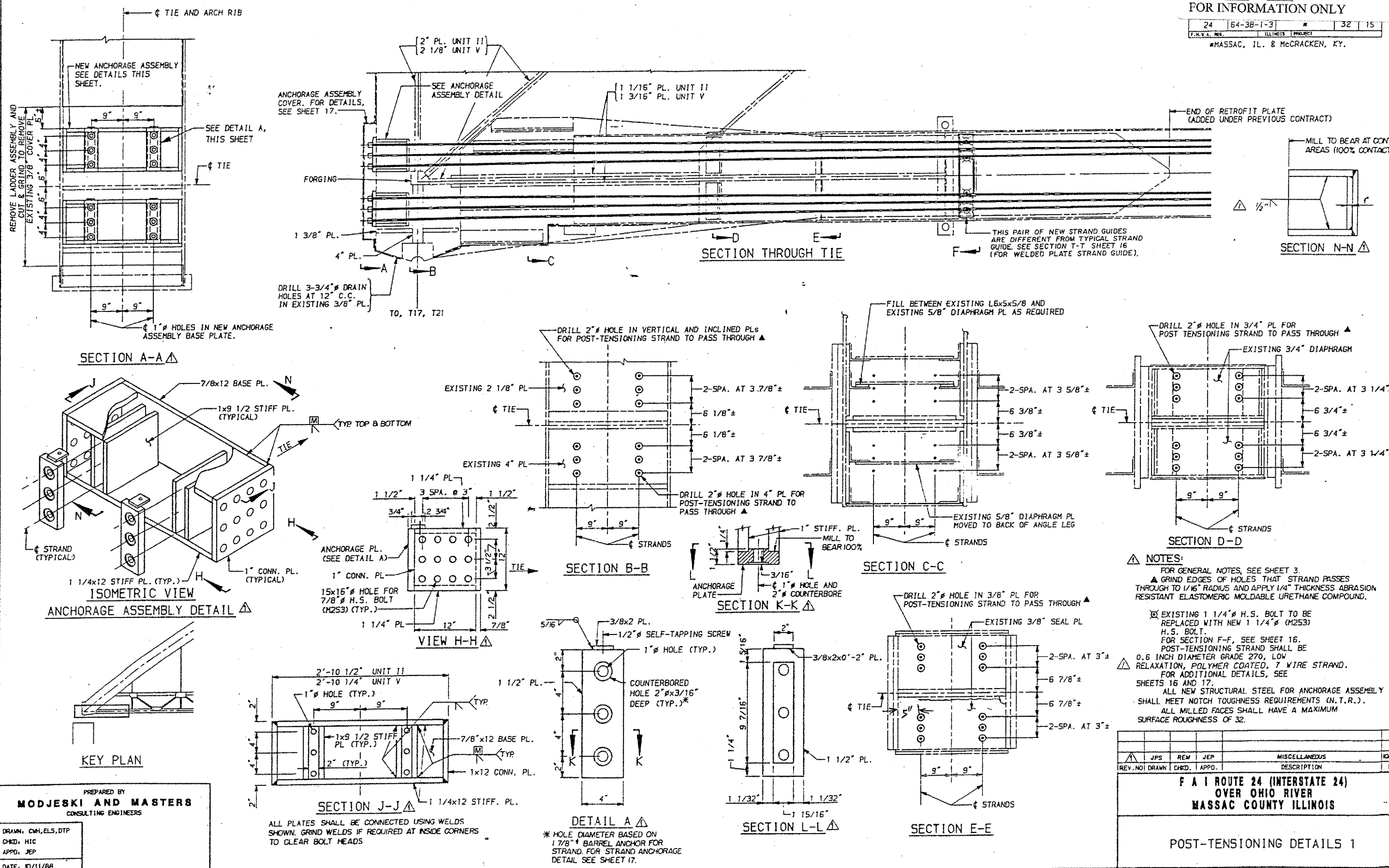

NOTES:
 FOR GENERAL NOTES, SEE SHEET 3.
 ▲ GRIND EDGES OF HOLES THAT STRAND PASSES THROUGH TO 1/16" RADIUS AND APPLY 1/4" THICKNESS ABRASION RESISTANT ELASTOMERIC MOLDABLE URETHANE COMPOUND.
 ☐ EXISTING 1 1/4" H.S. BOLT TO BE REPLACED WITH NEW 1 1/4" (M253) H.S. BOLT.
 FOR SECTION F-F, SEE SHEET 16.
 POST-TENSIONING STRAND SHALL BE 0.6 INCH DIAMETER GRADE 270, LOW RELAXATION, POLYMER COATED, 7 WIRE STRAND.
 FOR ADDITIONAL DETAILS, SEE SHEETS 16 AND 17.
 ALL NEW STRUCTURAL STEEL FOR ANCHORAGE ASSEMBLY SHALL MEET NOTCH TOUGHNESS REQUIREMENTS (N.T.R.).
 ALL MILLED FACES SHALL HAVE A MAXIMUM SURFACE ROUGHNESS OF 32.

JPS	REW	JEP	MISCELLANEOUS	10/27/88
REV. NO.	DRAWN	CHKD.	APPD.	DESCRIPTION

**F A I ROUTE 24 (INTERSTATE 24)
 OVER OHIO RIVER
 MASSAC COUNTY ILLINOIS**

POST-TENSIONING DETAILS 1

PREPARED BY
MODJESKI AND MASTERS
 CONSULTING ENGINEERS
 DRAWN: CWH, ELS, DTP
 CHKD: HIC
 APPD: JEP
 DATE: 10/11/88

ALL PLATES SHALL BE CONNECTED USING WELDS SHOWN. GRIND WELDS IF REQUIRED AT INSIDE CORNERS TO CLEAR BOLT HEADS

* HOLE DIAMETER BASED ON 1 7/8" BARREL ANCHOR FOR STRAND. FOR STRAND ANCHORAGE DETAIL SEE SHEET 17.

24	64-3B-I-3	32	16
----	-----------	----	----

ILLINOIS PROJECT
 MASSAC, IL. & McCracken, KY.

BAR 1/4x7/8x0'-2 5/8"
 EPOXY COATED
 (ASTM A 36)

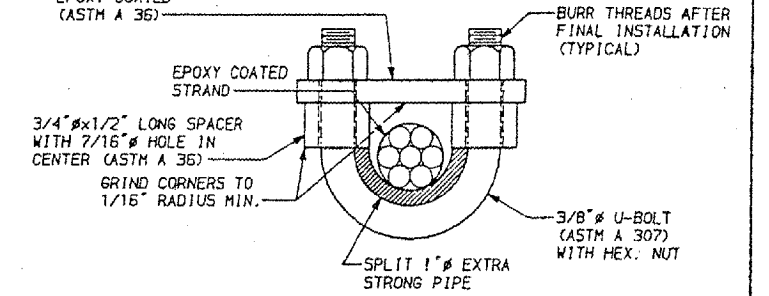

SECTION U-U

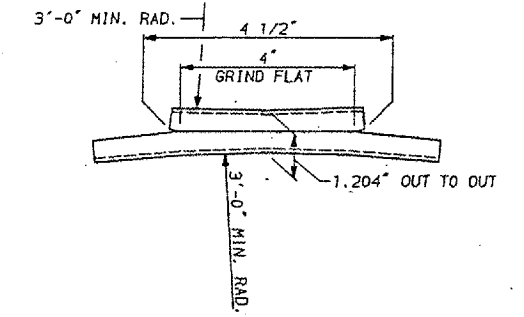

DETAIL S

REMOVE EXISTING FULL DEPTH DIAPHRAGM CONSISTING OF PLATE AND ANGLES. REPLACE ALL FASTENERS IN KIND.

NOTES:
 FOR GENERAL NOTES, SEE SHEET 3.
 FOR ADDITIONAL DETAILS, SEE SHEETS 15 AND 17.
 FOR LOCATION OF SECTION F-F, SEE SHEET 15.

REV. NO.	DRAWN	CHKD.	APPD.	DESCRIPTION	DATE
1	JPS	REM	JEP	MISCELLANEOUS	10/25/88

F A I ROUTE 24 (INTERSTATE 24)
 OVER OHIO RIVER
 MASSAC COUNTY ILLINOIS

POST-TENSIONING DETAILS 2

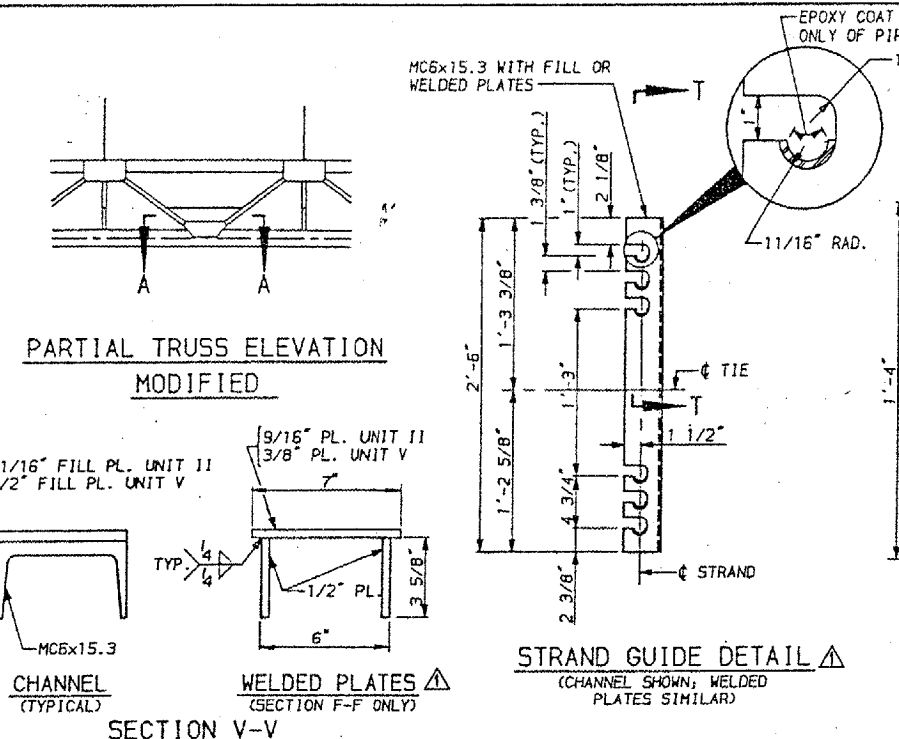

SECTION V-V

STRAND GUIDE DETAIL
 (CHANNEL SHOWN; WELDED PLATES SIMILAR)

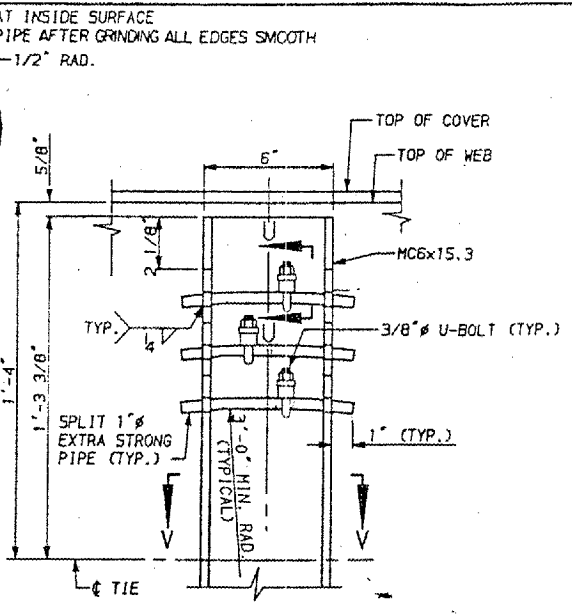

SECTION T-T
 (FOR CHANNEL STRAND GUIDE)
 (UNIT II - 60 REQ'D, UNIT V - 76 REQ'D)

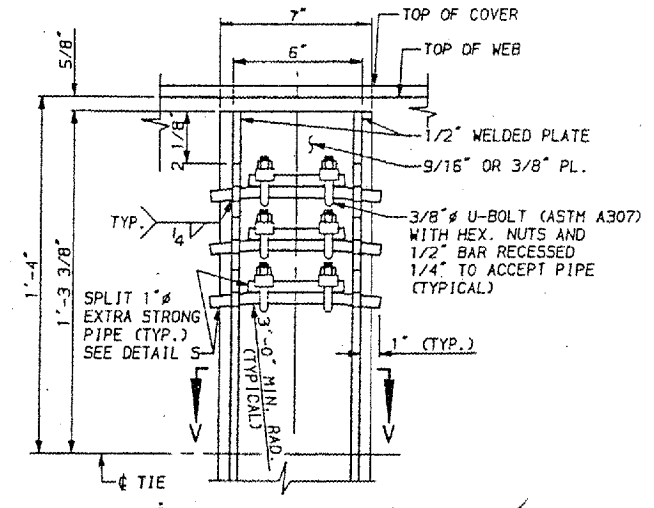

SECTION T-T
 (FOR WELDED PLATE STRAND GUIDE)
 (UNIT II - 8 REQ'D, UNIT V - 8 REQ'D)

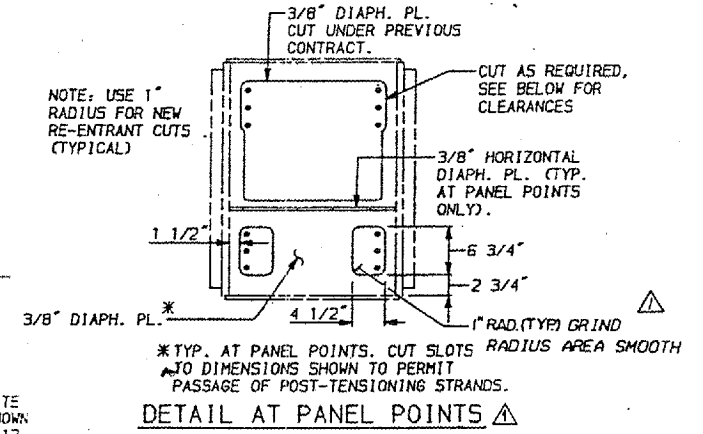

DETAIL AT PANEL POINTS

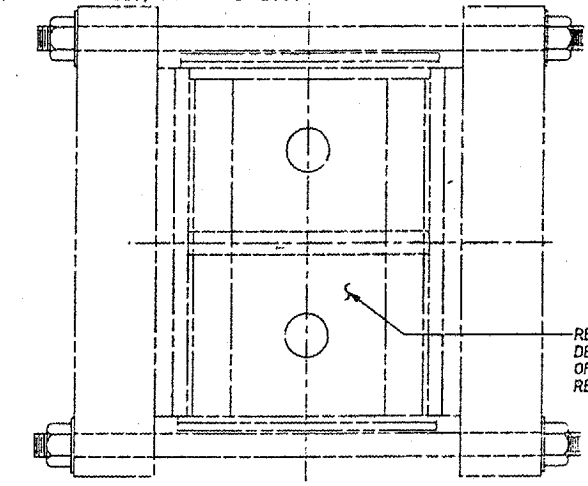

SECTION F-F
 EXISTING CONDITION

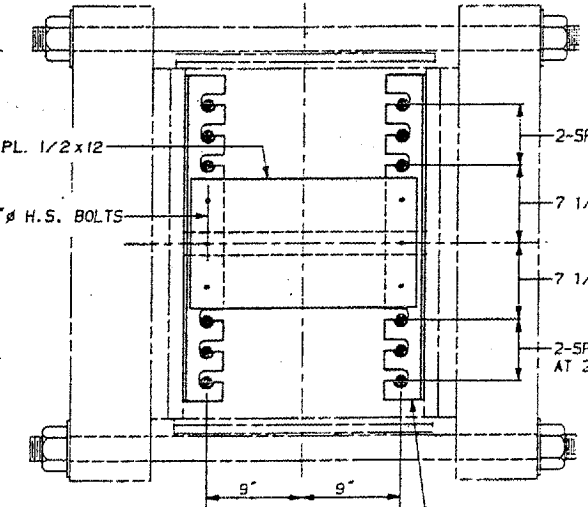

SECTION F-F
 NEW CONDITION

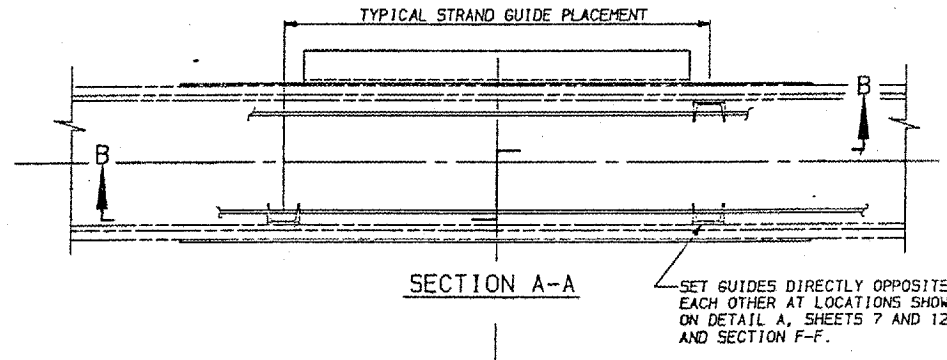

SECTION A-A

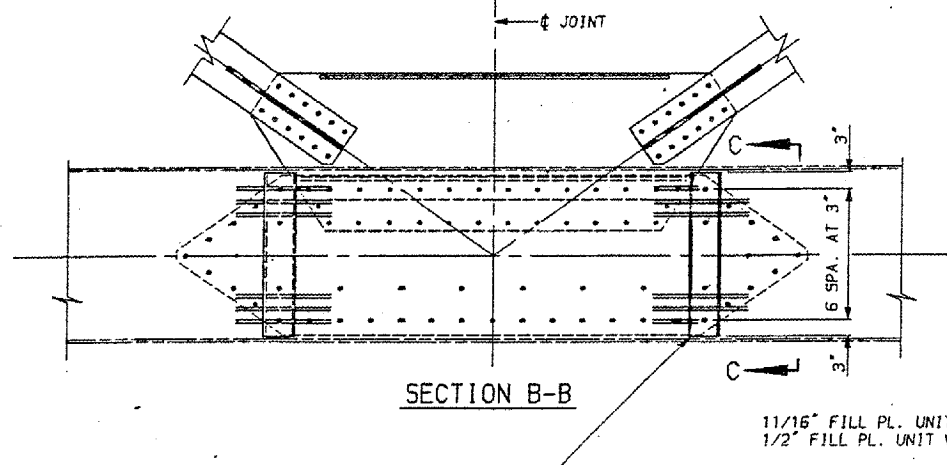

SECTION B-B

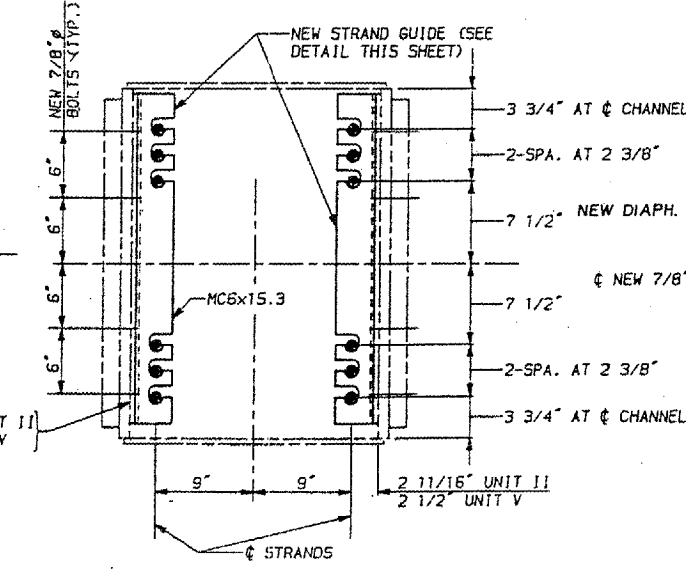

SECTION C-C

TYPICAL STRAND GUIDE. SEE SECTION T-T, THIS SHEET (FOR CHANNEL STRAND GUIDE).

PREPARED BY
MODJESKI AND MASTERS
 CONSULTING ENGINEERS

DRAWN: DTP
 CHKD: HJC
 APPD: JEP
 DATE: 10/11/88

24	64-3B-1-3	*	32	17
ILLINOIS PROJECT				
MASSAC, IL. & McCRACKEN, KY.				

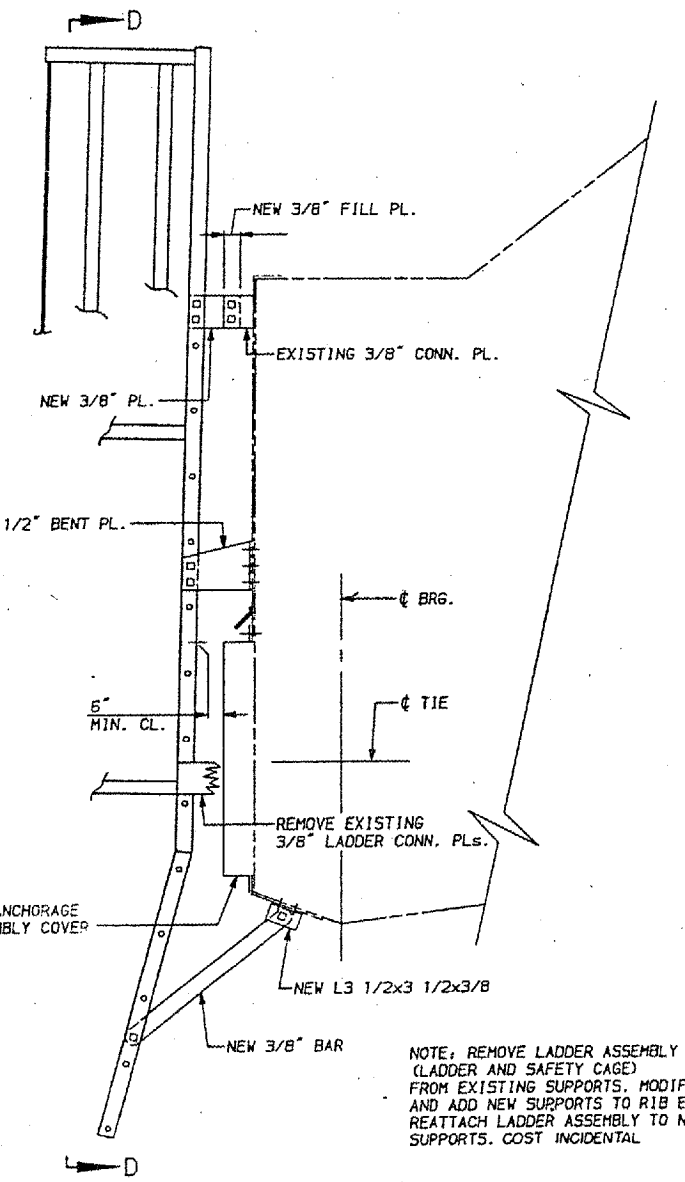
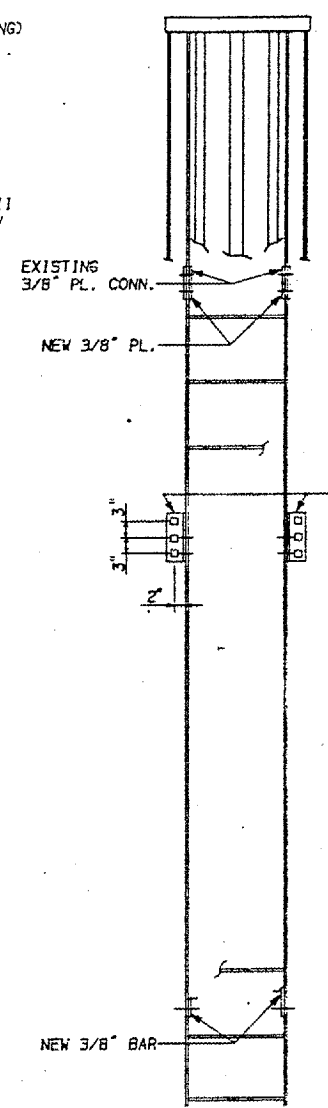
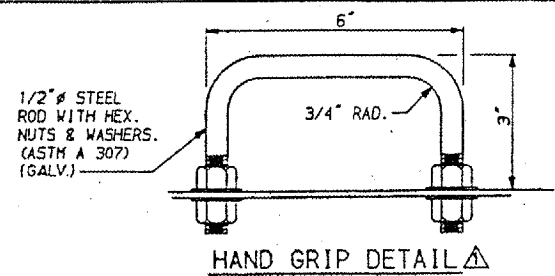
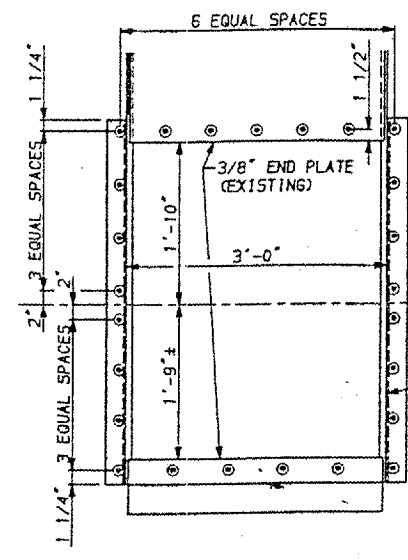
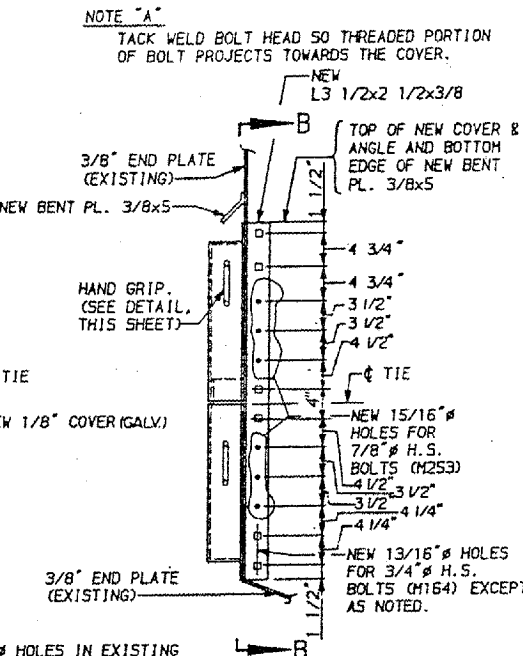
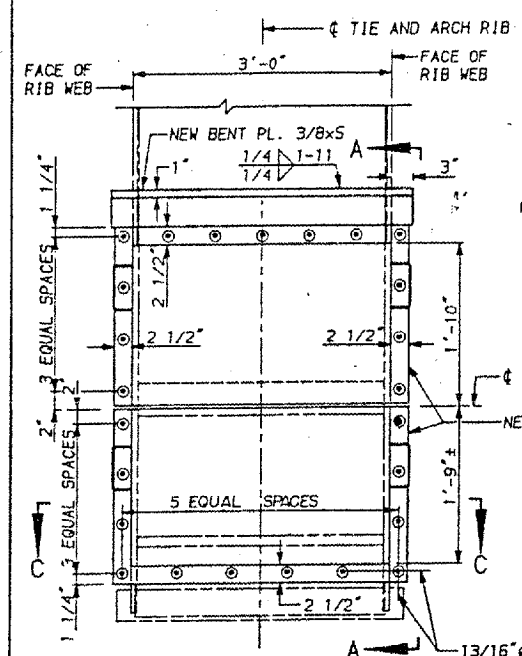

ANCHORAGE ASSEMBLY COVER DETAIL A

VIEW A-A

VIEW B-B

HAND GRIP DETAIL A

VIEW D-D

LADDER SUPPORT MODIFICATION D

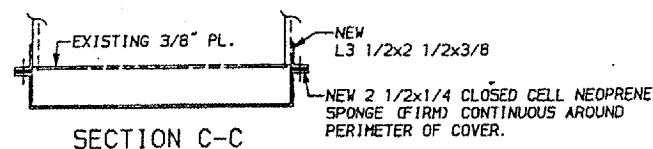

SECTION C-C

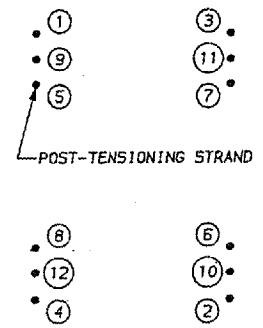

STRAND TENSIONING SEQUENCE

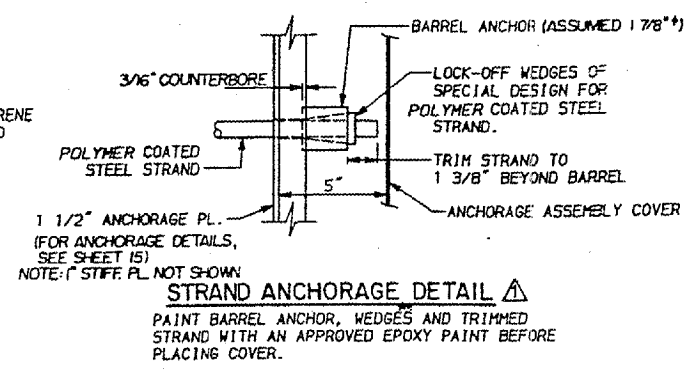

STRAND ANCHORAGE DETAIL A

STRAND DATA: 0.5 INCH DIAMETER, (AREA=0.217 IN²) POLYMER COATED SEVEN-WIRE LOW RELAXATION STEEL STRAND CONFORMING TO ASTM A416, GRADE 270.

	UNIT II	UNIT V
FSU	270,000 PSI	270,000 PSI
FS'I	158,000 PSI	202,500 PSI
FS'A	153,000 PSI	193,500 PSI

WHERE FS'I = MAXIMUM INITIAL LOAD AFTER ANCHORAGE
 FS'A = DESIGN LOAD

NOTES:

- FOR GENERAL NOTES, SEE SHEET 3.
- NEW GALVANIZED ANCHORAGE ASSEMBLY COVER SHALL ALSO BE PAINTED WITH THE SAME INTERMEDIATE COAT AND TOP COAT AS USED IN THE THREE COAT PAINT SYSTEM.
- Ø13/16" HOLE IN EXISTING 3/8" PL OR NEW ANGLE AND 7/8" HOLE IN NEW 1/8" COVER FOR 3/4" H.S. BOLT (M164)
- ØNEW 13/16" HOLES FOR 3/4" H.S. BOLTS (M164).
- PREPARE GALVANIZED SURFACES BY USING WASH COAT AFTER CLEANING.

REV.	NO.	DATE	DESCRIPTION

F A I ROUTE 24 (INTERSTATE 24)
 OVER OHIO RIVER
 MASSAC COUNTY ILLINOIS

POST-TENSIONING DETAILS 3

PREPARED BY
MODJESKI AND MASTERS
 CONSULTING ENGINEERS

DATE: 10/11/88

ITEM	QUANTITIES		
	UNIT	UNIT II	UNIT V
POST-TENS. STRAND	L.F.	15,120	17,520
STRUCTURAL STEEL	LBS.	10,300	10,300

24	64-3B-1-3	32	18
ILLINOIS PROJECT			
*MASSAC, IL. & McCRACKEN, KY.			

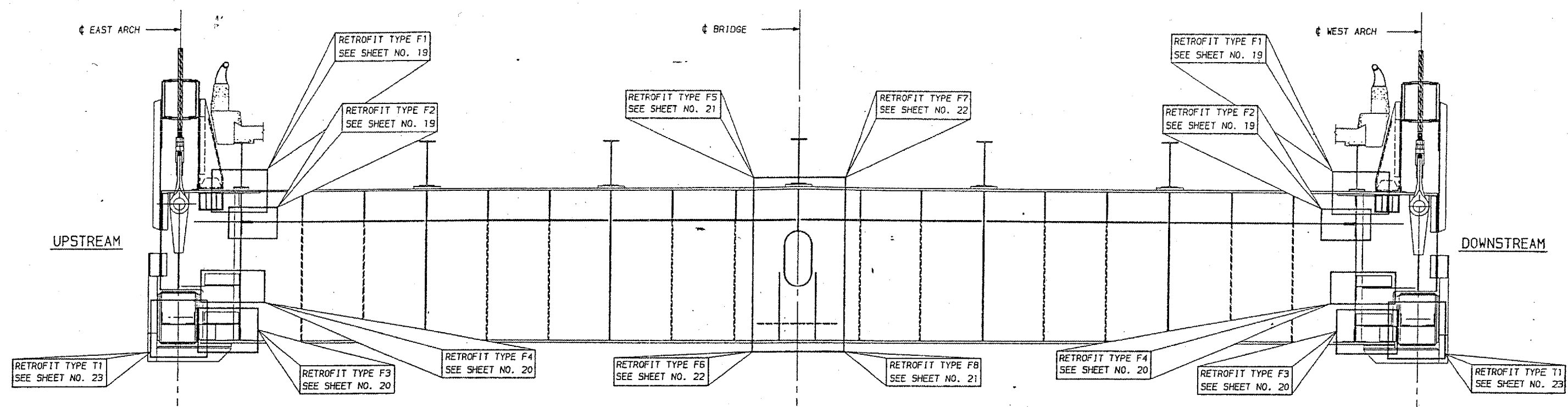

FLOORBEAM ELEVATION

RETROFIT LOCATIONS - UNIT II		RETROFIT TYPE													
PANEL POINT		F1	F1	F2	F2	F3	F3	F4	F4	F5	F6	F7	F8	T1	T1
		US	DS	US	DS	US	DS	US	DS	X	X	X	X	US	DS
0															
1		•	•	•	•	•	•	•	•			•		•	•
2		•	•	•	•	•	•	•	•		•			•	•
3		•	•	•	•	•	•	•	•				•	•	•
4		•	•	•	•	•	•	•	•					•	•
5		•	•	•	•	•	•	•	•					•	•
6		•	•	•	•	•	•	•	•					•	•
7		•	•	•	•	•	•	•	•					•	•
8		•	•	•	•	•	•	•	•				•	•	•
9		•	•	•	•	•	•	•	•					•	•
10		•	•	•	•	•	•	•	•					•	•
11		•	•	•	•	•	•	•	•					•	•
12		•	•	•	•	•	•	•	•					•	•
13		•	•	•	•	•	•	•	•					•	•
14		•	•	•	•	•	•	•	•					•	•
15		•	•	•	•	•	•	•	•					•	•
16		•	•	•	•	•	•	•	•					•	•
17															
NUMBER OF EACH		16	16	16	16	15	16	16	15	1	2	7	8	16	16

RETROFIT LOCATIONS - UNIT V		RETROFIT TYPE													
PANEL POINT		F1	F1	F2	F2	F3	F3	F4	F4	F5	F6	F7	F8	T1	T1
		US	DS	US	DS	US	DS	US	DS	X	X	X	X	US	DS
0															
1		•	•	•	•	•	•	•	•					•	•
2		•	•	•	•	•	•	•	•					•	•
3		•	•	•	•	•	•	•	•					•	•
4		•	•	•	•	•	•	•	•					•	•
5		•	•	•	•	•	•	•	•					•	•
6		•	•	•	•	•	•	•	•					•	•
7		•	•	•	•	•	•	•	•					•	•
8		•	•	•	•	•	•	•	•					•	•
9		•	•	•	•	•	•	•	•					•	•
10		•	•	•	•	•	•	•	•					•	•
11		•	•	•	•	•	•	•	•					•	•
12		•	•	•	•	•	•	•	•					•	•
13		•	•	•	•	•	•	•	•					•	•
14		•	•	•	•	•	•	•	•					•	•
15		•	•	•	•	•	•	•	•					•	•
16		•	•	•	•	•	•	•	•					•	•
17		•	•	•	•	•	•	•	•					•	•
18		•	•	•	•	•	•	•	•					•	•
19		•	•	•	•	•	•	•	•					•	•
20		•	•	•	•	•	•	•	•					•	•
21															
NUMBER OF EACH		20	20	20	20	19	19	20	19	3	2	9	8	20	20

NOTES:
 FOR GENERAL NOTES, SEE SHEET 3.
 FOR RETROFIT DETAILS, SEE SHEETS 19 THRU 23.
 ▲ DENOTES MODIFIED RETROFIT TYPE F3.
 SEE GENERAL PROCEDURE NO. 1 SHEET 20.
 DS DENOTES DOWNSTREAM
 US DENOTES UPSTREAM

PREPARED BY
MODJESKI AND MASTERS
 CONSULTING ENGINEERS
 DRAWN: CMH
 CHKD: TBH
 APPD: JEP
 DATE: 10/11/88

REV. NO.	DRAWN	CHKD.	APPD.	DESCRIPTION	DATE
				F A I ROUTE 24 (INTERSTATE 24) OVER OHIO RIVER MASSAC COUNTY ILLINOIS	
RETROFIT LOCATIONS					

24	64-3B-1-3	32	19
F.A.I. ROUTE 24		ILLINOIS PROJECT	
#MASSAC, IL. & McCRACKEN, KY.			

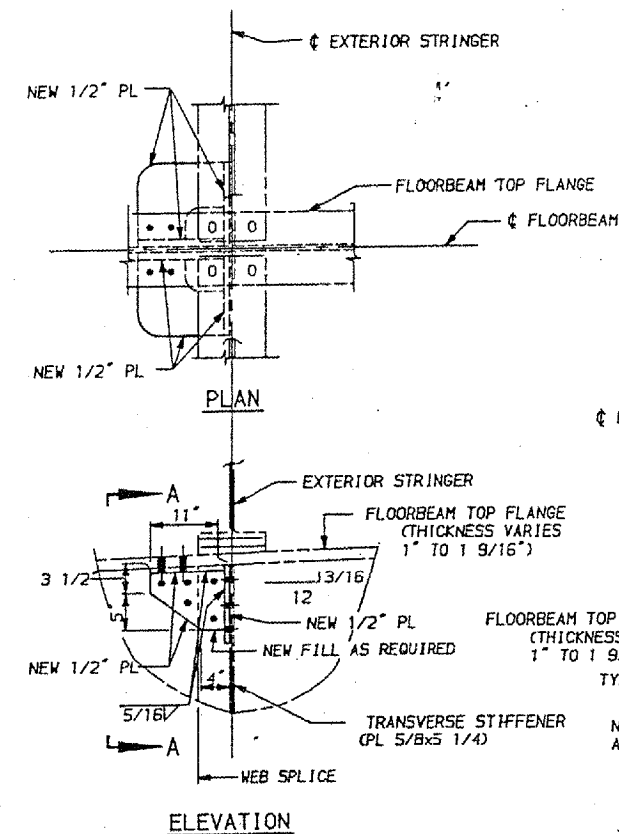

RETROFIT TYPE F1
 (EXPANSION POINT SHOWN
 ALL OTHERS SIMILAR)

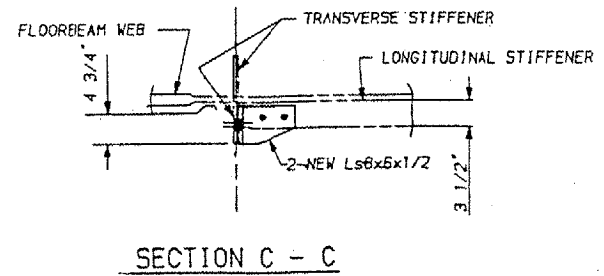

SECTION C - C

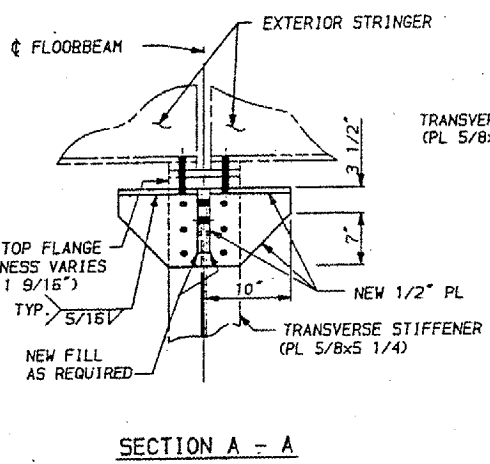

SECTION A - A

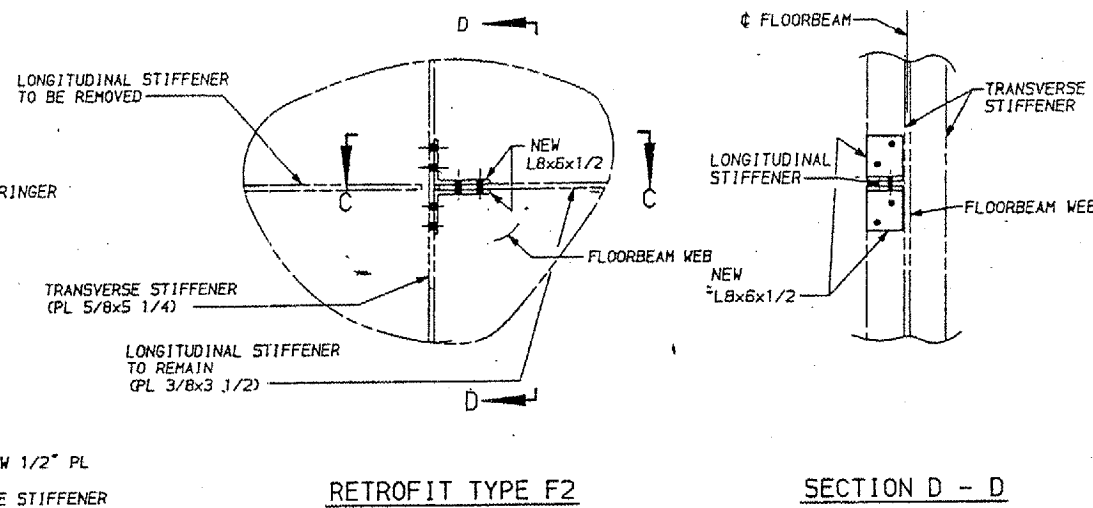

RETROFIT TYPE F2

SECTION D - D

RETROFIT TYPE F1

GENERAL PROCEDURE:

1. SANDBLAST TO REMOVE PAINT FROM THE UNDERSIDE OF THE TOP FLANGE AND THE CONTACT SURFACE ON THE TRANSVERSE STIFFENER. PAINT SHOULD BE REMOVED FROM THE TOP FLANGE APPROXIMATELY 15" FROM THE TRANSVERSE STIFFENER AND FROM THE TRANSVERSE STIFFENER APPROXIMATELY 12" FROM THE TOP FLANGE ON BOTH SIDES OF THE WEB.
2. USE DYE PENETRANT TO CHECK THE FLOORBEAM WEB FOR CRACKS IN THE GAP BETWEEN THE END OF THE TRANSVERSE STIFFENER AND THE TOP FLANGE (SEE DYE PENETRANT AREAS). IF THE WEB IS CRACKED, DRILL A 15/16" DIAMETER HOLE AT THE CRACK TIP AND DEBURR HOLE. USE DYE PENETRANT ON THE NEWLY EXPOSED (DRILLED) SURFACE OF THE FLOORBEAM WEB TO ENSURE THAT THE CRACK DOES NOT EXTEND PAST THE HOLE. IF THE CRACK EXTENDS PAST THE HOLE, GRIND TO REMOVE CRACK OR DRILL ANOTHER HOLE. REPEAT DYE PENETRANT CHECK.
3. SECURE HORIZONTAL PLATE OF WELDMENT TO TOP FLANGE IN ITS FINAL POSITION SO THAT THE VERTICAL PLATE IS TIGHT AGAINST THE TRANSVERSE STIFFENER. USING THE NEW PLATES AS A TEMPLATE, DRILL HOLES IN THE TOP FLANGE, TRANSVERSE STIFFENER AND WEB.
4. SECURE WELDMENT TO OTHER SIDE OF WEB USING HOLES IN WEB. DRILL HOLES IN TRANSVERSE STIFFENER AND TOP FLANGE USING THE WELDMENT AS A TEMPLATE.
5. REMOVE WELDMENT AND SOLVENT CLEAN ENTIRE RETROFIT AREA TO REMOVE CUTTING OIL. ALSO REMOVE OIL FROM FAYING SURFACES OF WELDMENT.
6. PLACE WELDMENTS IN THEIR FINAL POSITION AND INSTALL BOLTS.
7. PAINT ENTIRE RETROFIT AREA.

RETROFIT TYPE F2

GENERAL PROCEDURE:

1. CUT PORTION OF LONGITUDINAL STIFFENER BETWEEN SUSPENDER AND EXTERIOR STRINGER. REMOVE REMAINING WELD MATERIAL BY GRINDING TO SMOOTH FINISH (ANSI J25 MIN.)
2. SANDBLAST TO REMOVE PAINT FROM BOTH SIDES OF THE LONGITUDINAL STIFFENER AND THE ADJACENT SIDE OF THE TRANSVERSE STIFFENER.
3. USE DYE PENETRANT TO CHECK THE FLOORBEAM WEB FOR CRACKS IN THE GAP BETWEEN THE END OF THE LONGITUDINAL STIFFENER AND THE TRANSVERSE STIFFENER. IF THE WEB IS CRACKED, DRILL A 15/16" DIAMETER HOLE AT THE CRACK TIP AND DEBURR HOLE. USE DYE PENETRANT ON THE NEWLY EXPOSED (DRILLED) SURFACE OF THE FLOORBEAM WEB TO ENSURE THAT THE CRACK DOES NOT EXTEND PAST THE HOLE. IF THE CRACK EXTENDS PAST THE HOLE, GRIND TO REMOVE CRACK OR DRILL ANOTHER HOLE. REPEAT DYE PENETRANT CHECK.
4. SECURE ONE ANGLE IN ITS FINAL POSITION AND DRILL HOLES IN THE TRANSVERSE AND LONGITUDINAL STIFFENER USING THE ANGLE AS A TEMPLATE.
5. REMOVE THE FIRST ANGLE AND PLACE THE REMAINING ANGLE IN ITS FINAL POSITION. USE BOLT HOLES IN LONGITUDINAL STIFFENER TO SECURE ANGLE AND DRILL HOLES INTO THE TRANSVERSE STIFFENER.
6. REMOVE BOTH ANGLES AND SOLVENT CLEAN THE ENTIRE RETROFIT AREA TO REMOVE CUTTING OIL. ALSO REMOVE OIL FROM FAYING SURFACES OF THE ANGLES.
7. INSTALL ANGLES AND TIGHTEN BOLTS.
8. PAINT ENTIRE RETROFIT AREA.

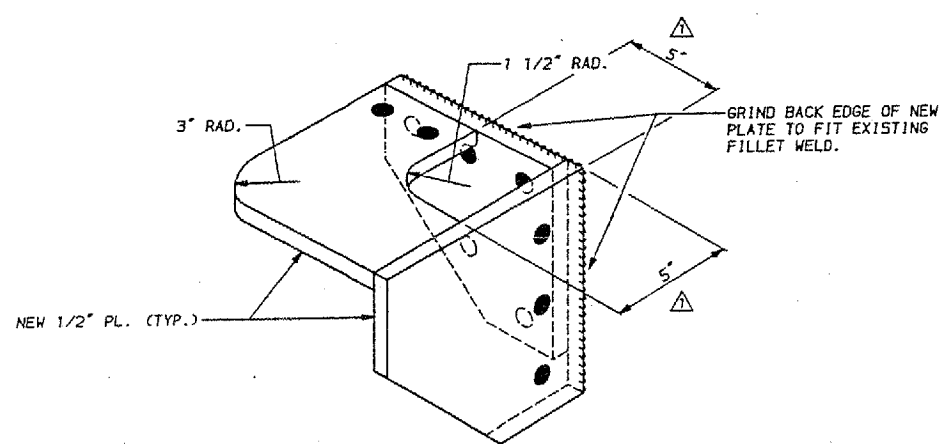

**ISOMETRIC VIEW
 RETROFIT TYPE F1**

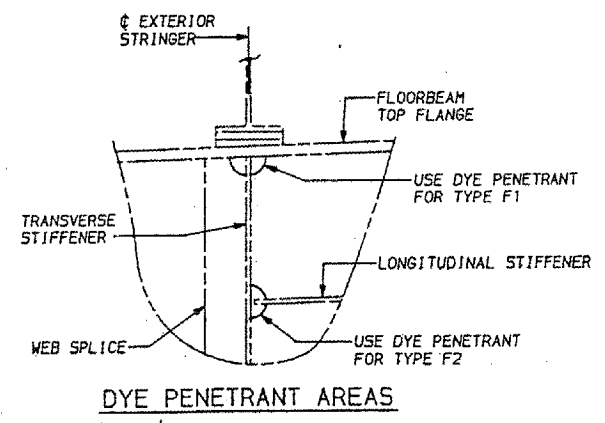

DYE PENETRANT AREAS

NOTES:

- FOR GENERAL NOTES, SEE SHEET 3.
- FOR RETROFIT LOCATIONS, SEE SHEET 18.
- ALL WORK SHALL BE DONE IN ACCORDANCE WITH THE SPECIAL PROVISIONS.
- DENOTES NEW 7/8" H.S. BOLT IN NEW HOLE.

QUANTITIES				
RETROFIT	ITEM	UNIT	UNIT I	UNIT V
TYPE F1	STRUCTURAL STEEL	LBS.	2,100	2,600
TYPE F2	STRUCTURAL STEEL	LBS.	600	700

PREPARED BY
MODJESKI AND MASTERS
 CONSULTING ENGINEERS

DATE: 10/11/88

SLH	REH	JEP	MISCELLANEOUS	10/24/88
REV. NO.	DRAWN	CHKD.	APPD.	DESCRIPTION

**F A I ROUTE 24 (INTERSTATE 24)
 OVER OHIO RIVER
 MASSAC COUNTY ILLINOIS**

24	64-3B-I-3	32	20
F.H.W.A. REC.		ILLINOIS PROJECT	
*MASSAC, IL. & McCRACKEN, KY.			

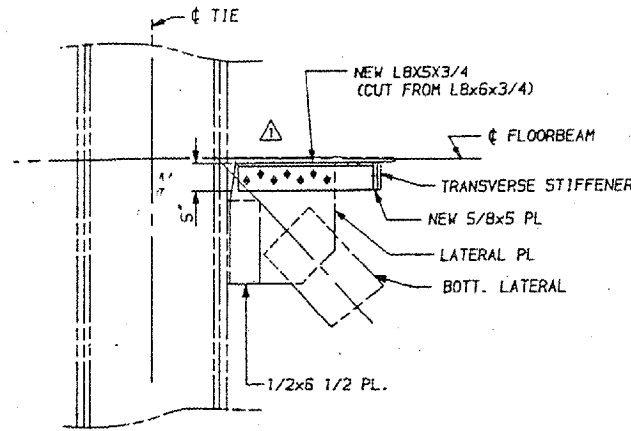

SECTION B - B

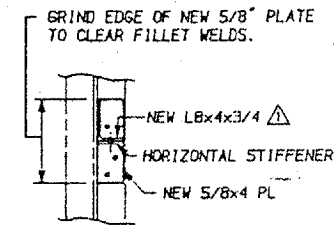

SECTION D - D

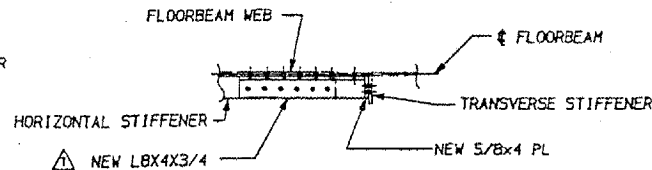

SECTION C - C

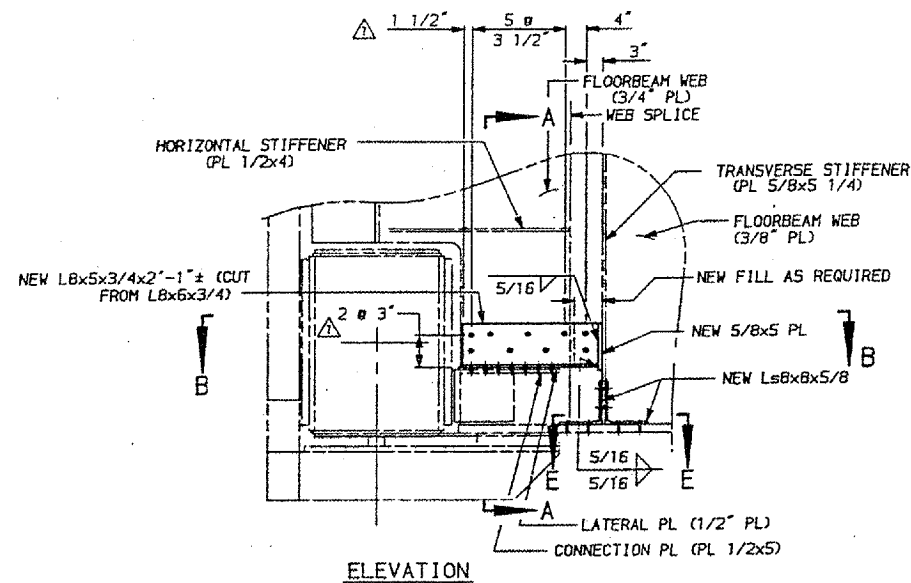

ELEVATION
RETROFIT TYPE F3

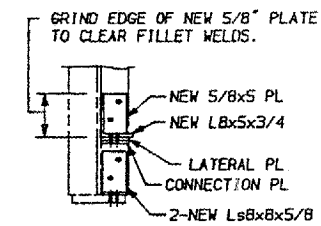

SECTION A - A

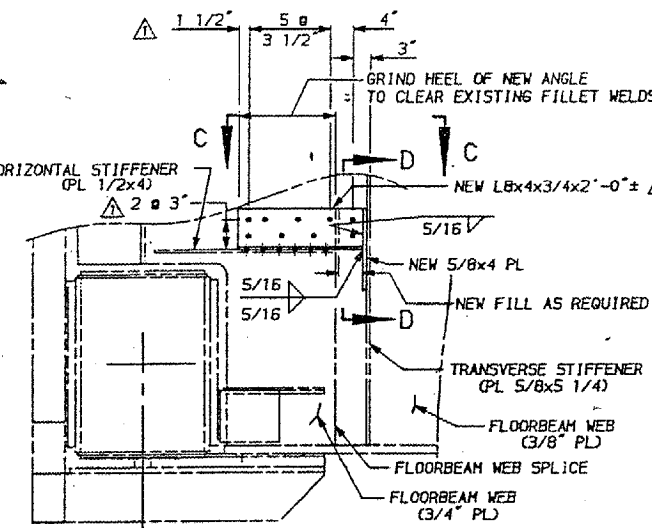

ELEVATION
RETROFIT TYPE F4

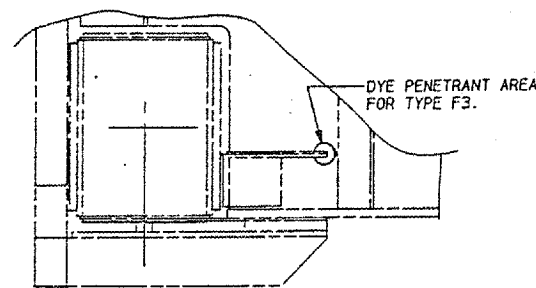

DYE PENETRANT AREA

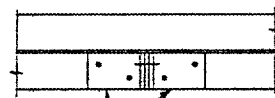

SECTION E - E

(NOTE: USE EXISTING HOLES FOR UNIT II, P.P. 8 DOWNSTREAM AND UNIT V, P.P. 10 DOWNSTREAM)

QUANTITIES				
RETROFIT	ITEM	UNIT	UNIT II	UNIT V
TYPE F3	STRUCTURAL STEEL	LBS.	3,400	4,100
TYPE F4	STRUCTURAL STEEL	LBS.	2,000	2,500

RETROFIT TYPE F3

GENERAL PROCEDURE:

1. SANDBLAST TO REMOVE PAINT FROM THE FLOORBEAM WEB IN AN AREA APPROXIMATELY 6" IN DIAMETER CENTERED ON THE LATERAL PLATE (SEE DYE PENETRANT AREA).
2. USE DYE PENETRANT TO CHECK THE FLOORBEAM WEB FOR CRACKS AT THE END OF THE LATERAL PLATE. IF THE WEB IS CRACKED, DRILL A 15/16" DIAMETER HOLE AT THE CRACK TIP AND DEBURR HOLE. USE DYE PENETRANT ON THE NEWLY EXPOSED (DRILLED) SURFACE OF THE FLOORBEAM WEB TO ENSURE THAT THE CRACK DOES NOT EXTEND PAST THE HOLE. IF THE CRACK EXTENDS PAST THE HOLE, GRIND TO REMOVE CRACK OR DRILL ANOTHER HOLE. REPEAT DYE PENETRANT CHECK. SOLVENT CLEAN AREA TO REMOVE CUTTING OIL.
3. REMOVE BOLTS FROM LATERAL PLATE TO FLOORBEAM CONNECTION. MAKE TEMPLATE OF HOLES IN EXISTING LATERAL PLATE. SANDBLAST TO REMOVE PAINT FROM ALL NEW FAYING SURFACES ON FLOORBEAM WEB AND EXISTING LATERAL PLATE.
4. DRILL UNDERSIZED HOLES IN NEW WELDMENT USING TEMPLATE.
5. SECURE NEW WELDMENT IN PLACE SO THAT THE VERTICAL LEG OF THE ANGLE IS TIGHT AGAINST THE FLOORBEAM WEB, THE HORIZONTAL LEG OF THE ANGLE IS TIGHT AGAINST THE LATERAL PLATE AND THE END PLATE OF THE NEW WELDMENT IS TIGHT AGAINST THE TRANSVERSE STIFFENER. DRILL HOLES IN THE FLOORBEAM WEB AND THE TRANSVERSE STIFFENER USING THE NEW WELDMENT AS A TEMPLATE. REAM HOLES IN THE NEW WELDMENT THROUGH LATERAL PLATE.
6. REMOVE NEW WELDMENT AND SOLVENT CLEAN ENTIRE RETROFIT AREA TO CLEAN AND REMOVE CUTTING OIL FROM FAYING SURFACES. SOLVENT CLEAN AND REMOVE CUTTING OIL FROM FAYING SURFACES OF WELDMENT.
7. PLACE WELDMENT IN THE FINAL POSITION AND INSTALL BOLTS.
8. SECURE ONE NEW ANGLE TO BOTTOM OF TRANSVERSE STIFFENER AND TO THE BOTTOM FLANGE.
9. DRILL HOLES IN TRANSVERSE STIFFENER AND BOTTOM FLANGE USING THE NEW ANGLE AS A TEMPLATE. REMOVE NEW ANGLE.
10. SECURE SECOND NEW ANGLE TO BOTTOM OF TRANSVERSE STIFFENER AND BOTTOM FLANGE. REAM UNDERSIZED HOLES IN VERTICAL LEG OF NEW ANGLE TO HOLES IN TRANSVERSE STIFFENER. DRILL HOLES IN BOTTOM FLANGE USING NEW ANGLE AS A TEMPLATE. REMOVE NEW ANGLE.
11. USE SOLVENT TO CLEAN AND REMOVE CUTTING OIL FROM ALL FAYING SURFACES. SOLVENT CLEAN TO REMOVE CUTTING OIL FROM FAYING SURFACES OF NEW ANGLES.
12. PLACE BOTH ANGLES IN FINAL POSITION AND INSTALL BOLTS.
13. PAINT ENTIRE RETROFIT AREA.
14. REMOVE EXISTING BENT PLATES CONNECTING TRANSVERSE STIFFENER ANGLE TO FLOORBEAM BOTTOM FLANGE. SECURE ONE NEW ANGLE TO BOTTOM OF TRANSVERSE STIFFENER AND TO THE BOTTOM FLANGE.
15. DRILL HOLES IN NEW ANGLES USING EXISTING HOLES IN TRANSVERSE STIFFENER AND BOTTOM FLANGE AS TEMPLATE. REMOVE NEW ANGLE.
16. SECURE SECOND NEW ANGLE TO BOTTOM OF TRANSVERSE STIFFENER AND TO THE BOTTOM FLANGE. USE EXISTING HOLES IN TRANSVERSE STIFFENER AND BOTTOM FLANGE AS A TEMPLATE TO DRILL HOLES IN NEW ANGLE. REMOVE NEW ANGLE.
17. PROCEED WITH STEPS 11 THRU 13 ABOVE.

RETROFIT TYPE F4

1. SECURE NEW WELDMENT IN PLACE SO THAT THE VERTICAL LEG OF THE ANGLE IS TIGHT AGAINST THE FLOORBEAM WEB, THE HORIZONTAL LEG OF THE ANGLE IS TIGHT AGAINST THE HORIZONTAL STIFFENER AND THE END PLATE IS TIGHT AGAINST THE TRANSVERSE STIFFENER. DRILL HOLES IN THE FLOORBEAM WEB, THE TRANSVERSE STIFFENER AND THE HORIZONTAL STIFFENER USING THE NEW WELDMENT AS A TEMPLATE.
2. REMOVE NEW WELDMENT. SOLVENT CLEAN TO REMOVE CUTTING OIL AND SANDBLAST TO REMOVE PAINT FROM FAYING SURFACES OF NEW WELDMENT AND FLOORBEAM WEB.
3. PLACE NEW WELDMENT IN FINAL POSITION AND INSTALL BOLTS.
4. PAINT ENTIRE RETROFIT AREA.

NOTES:

- FOR GENERAL NOTES SEE SHEET 3.
- FOR RETROFIT LOCATIONS SEE SHEET 18.
- ALL WORK SHALL BE DONE IN ACCORDANCE WITH THE SPECIAL PROVISIONS.
- DENOTES NEW 7/8" # H.S. BOLT IN NEW HOLE.
- DENOTES NEW 7/8" # H.S. BOLT IN EXISTING HOLE.

REV. NO.	DATE	BY	CHKD.	APPRO.	DESCRIPTION	DATE
1	10/24/88	SLH	REM	JEP	MISCELLANEOUS	10/24/88

F A I ROUTE 24 (INTERSTATE 24)
 OVER OHIO RIVER
 MASSAC COUNTY ILLINOIS

RETROFIT DETAILS 2

PREPARED BY
MODJESKI AND MASTERS
 CONSULTING ENGINEERS

DRAWN: CMH
 CHKD: TBN
 APPD: JEP

DATE: 10/11/88

24	64-3B-1-3	32	21
ILLINOIS PROJECT			
MASSAC, IL. & McCRACKEN, KY.			

RETROFIT TYPE F5 AND TYPE F8

GENERAL PROCEDURE:

1. CUT VERTICAL STIFFENER ON BOTH SIDES OF THE FLOORBEAM AS SHOWN IN SECTION E - E. GRIND CUT SURFACE TO SMOOTH FINISH.
2. SANDBLAST CLEAN TO REMOVE PAINT FROM THE FLOORBEAM WEB AND TOP OF MANHOLE STIFFENER WITHIN 6" OF EACH SIDE OF CENTER LINE OF FLOORBEAM.
3. USE DYE PENETRANT TO CHECK THE FLOORBEAM WEB FOR CRACKS AT THE LOCATIONS SHOWN ON THE SHORT TRANSVERSE STIFFENER ABOVE THE ACCESS HOLE. IF THE WEB IS CRACKED, DRILL A 15/16" DIAMETER HOLE AT THE CRACK TIP AND DEBURR HOLE. USE DYE PENETRANT ON THE NEWLY EXPOSED (DRILLED) SURFACE OF THE FLOORBEAM WEB TO ENSURE THAT THE CRACK DOES NOT EXTEND PAST THE HOLE. IF THE CRACK EXTENDS PAST THE HOLE, GRIND TO REMOVE CRACK OR DRILL ANOTHER HOLE. REPEAT DYE PENETRANT CHECK.
4. BLAST CLEAN TO REMOVE PAINT FROM FLOORBEAM WEB WITHIN AN AREA 6" IN DIAMETER AND CENTERED AT THE TOP OF THE EXISTING CUT SHORT TRANSVERSE STIFFENERS ON BOTH SIDES OF THE MANHOLE.
5. USE DYE PENETRANT TO CHECK THE FLOORBEAM WEB FOR CRACKS AT THE TOP OF THE EXISTING CUT SHORT TRANSVERSE STIFFENERS ON BOTH SIDES OF THE MANHOLE. IF THE WEB IS CRACKED, DRILL A 15/16" DIAMETER HOLE AT THE CRACK TIP AND DEBURR HOLE. USE DYE PENETRANT ON THE NEWLY EXPOSED (DRILLED) SURFACE OF THE FLOORBEAM WEB TO ENSURE THAT THE CRACK DOES NOT EXTEND PAST THE HOLE. IF THE CRACK EXTENDS PAST THE HOLE, GRIND TO REMOVE CRACK OR DRILL ANOTHER HOLE. REPEAT DYE PENETRANT CHECK.
6. REPEAT STEPS 2, 3, 4 AND 5 FOR THE OPPOSITE SIDE OF THE FLOORBEAM WEB.
7. SECURE NEW WELDMENT TO THE TOP FLANGE SO THAT THE VERTICAL LEG IS TIGHT AGAINST THE OUTSTANDING LEG OF THE EXISTING VERTICAL STIFFENER ANGLE. USING THE NEW WELDMENT AS A TEMPLATE, DRILL HOLES IN THE TOP FLANGE AND THE OUTSTANDING LEG OF THE VERTICAL ANGLE.
8. REMOVE WELDMENT AND SOLVENT CLEAN ALL FAYING SURFACES. REMOVE CUTTING OIL FROM FAYING SURFACES ON EXISTING VERTICAL, FLOORBEAM FLANGE AND WELDMENT. SANDBLAST TO REMOVE PAINT FROM ALL NEW FAYING SURFACES.
9. PLACE WELDMENT IN FINAL POSITION AND INSTALL BOLTS.
10. PAINT RETROFIT AREA.
11. REPEAT STEPS 7, 8, 9 AND 10 FOR ATTACHING WELDMENT TO BOTTOM FLANGE.

RETROFIT F8 ONLY

NOTES:

- FOR GENERAL NOTES, SEE SHEET 3.
- FOR RETROFIT LOCATIONS, SEE SHEET 18.
- ALL WORK SHALL BE DONE IN ACCORDANCE WITH THE SPECIAL PROVISIONS.
- DENOTES EXISTING 7/8" H.S. BOLT IN EXISTING HOLE.
- DENOTES NEW 7/8" H.S. BOLT IN NEW HOLES.

REV. NO.	DRAWN	CHKD.	APPD.	DESCRIPTION	DATE

**F A I ROUTE 24 (INTERSTATE 24)
 OVER OHIO RIVER
 MASSAC COUNTY ILLINOIS**

RETROFIT DETAILS 3

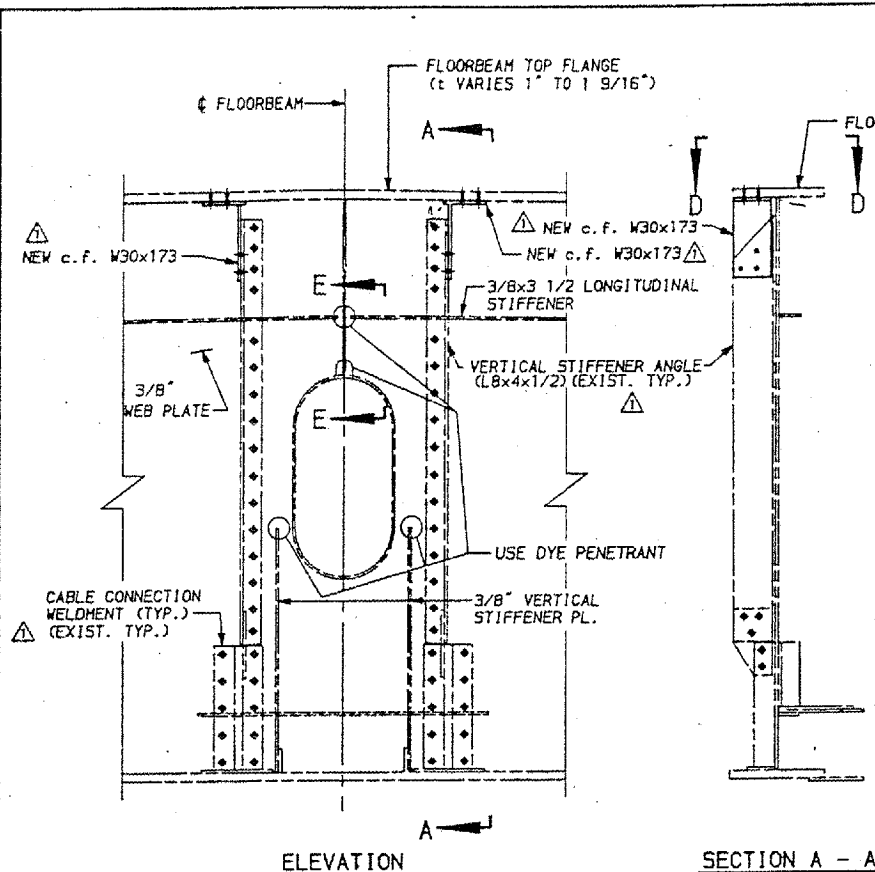

RETROFIT TYPE F5

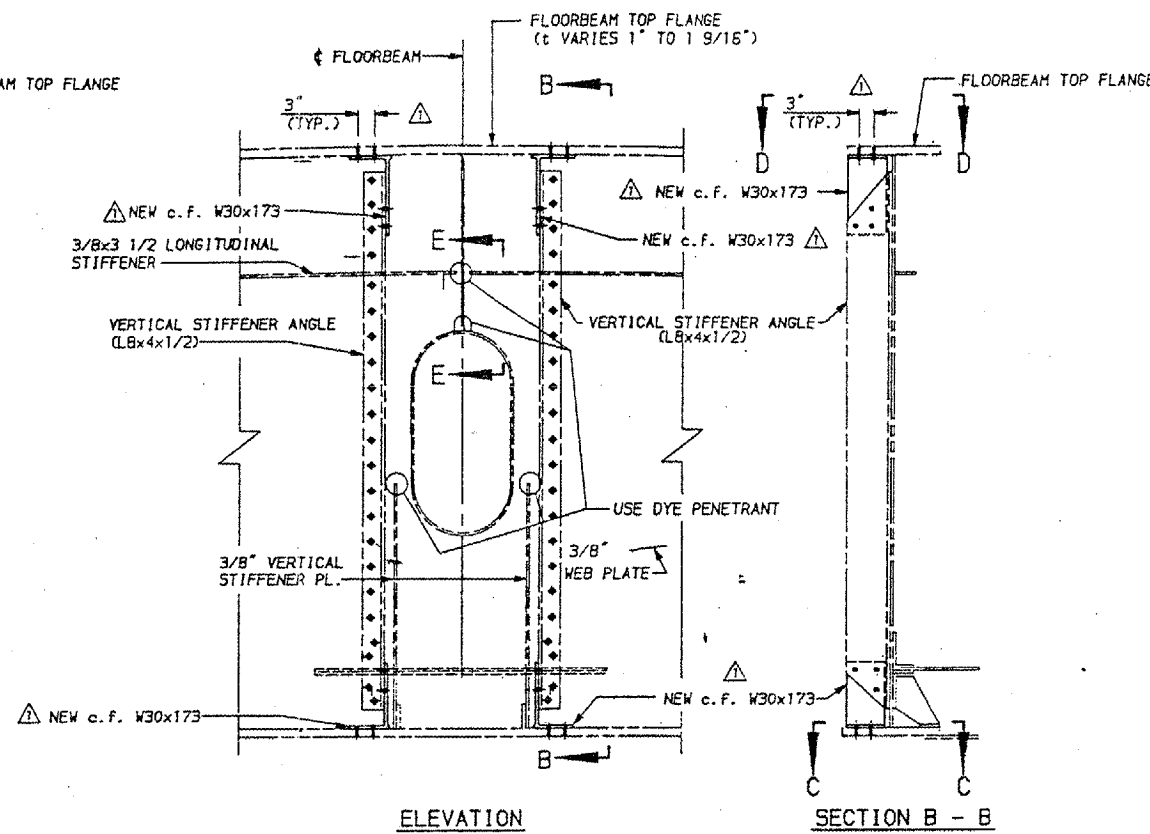

RETROFIT TYPE F8

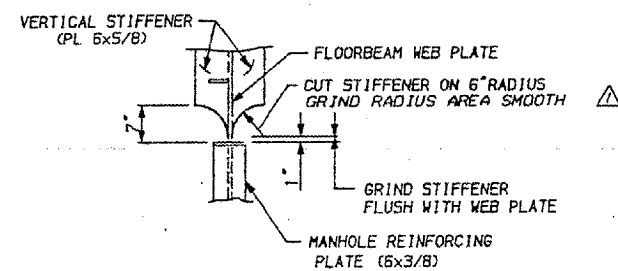

SECTION E - E

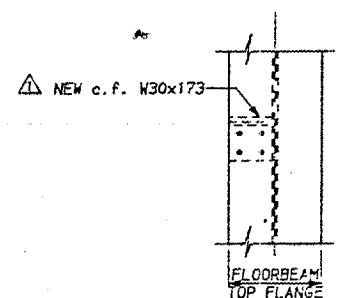

SECTION D-D

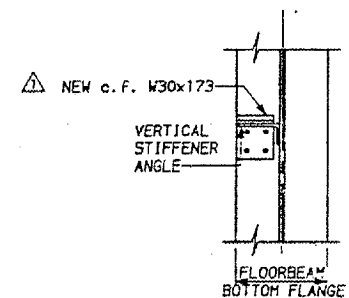

SECTION C-C

QUANTITIES				
RETROFIT	ITEM	UNIT	UNIT II	UNIT V
TYPE F5	STRUCTURAL STEEL	LBS.	102	200
TYPE F8	STRUCTURAL STEEL	LBS.	900	900

PREPARED BY
MODJESKI AND MASTERS
 CONSULTING ENGINEERS

DRAWN: CMH
 CHKD: TBM
 APPD: JEP
 DATE: 10/11/88

24	64-3B-I-3	#	32	22
ILLINOIS PROJECT		MASSAC, IL. & McCRACKEN, KY.		

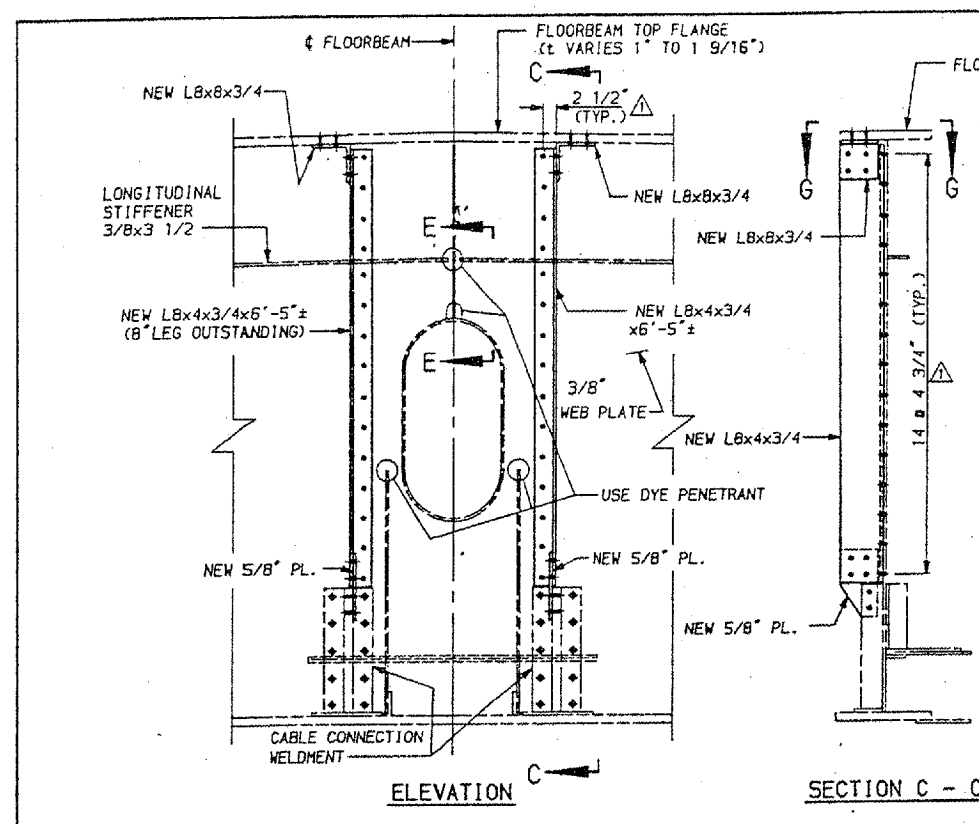

RETROFIT TYPE F6

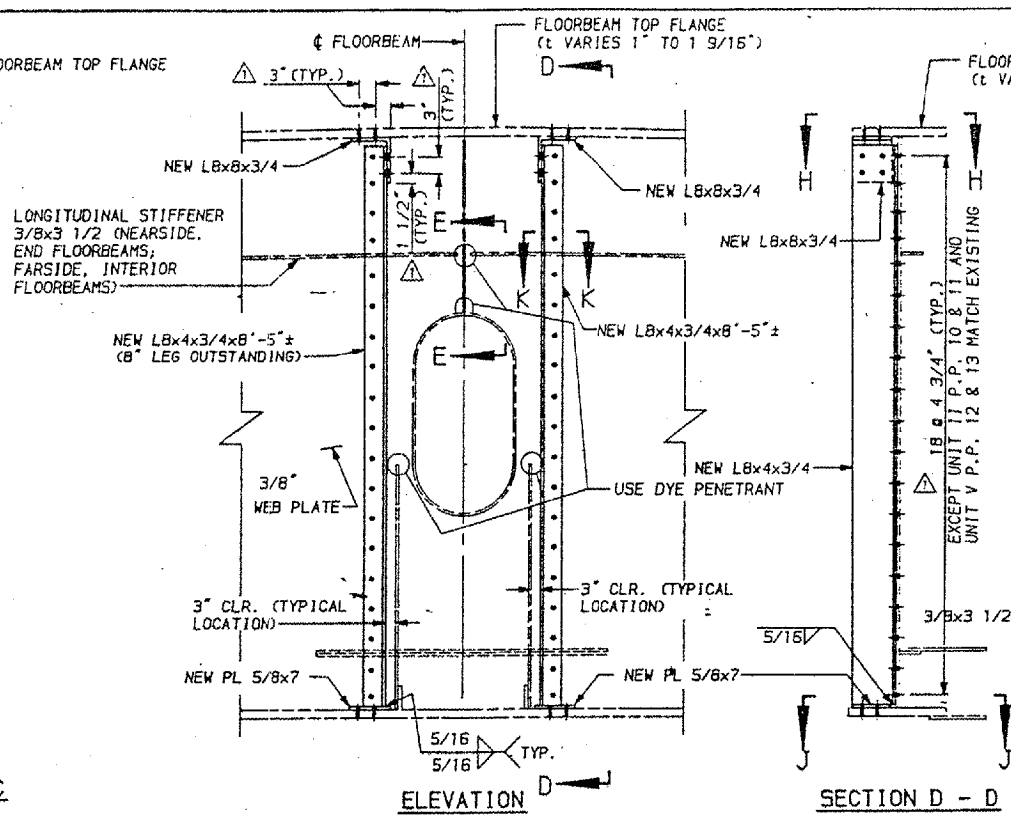

RETROFIT TYPE F7

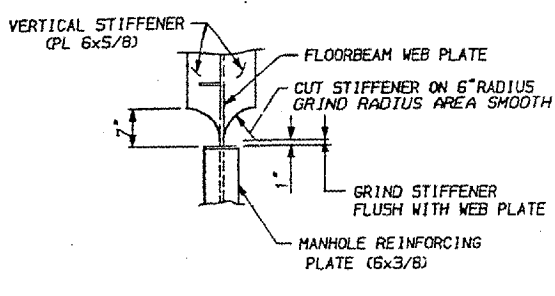
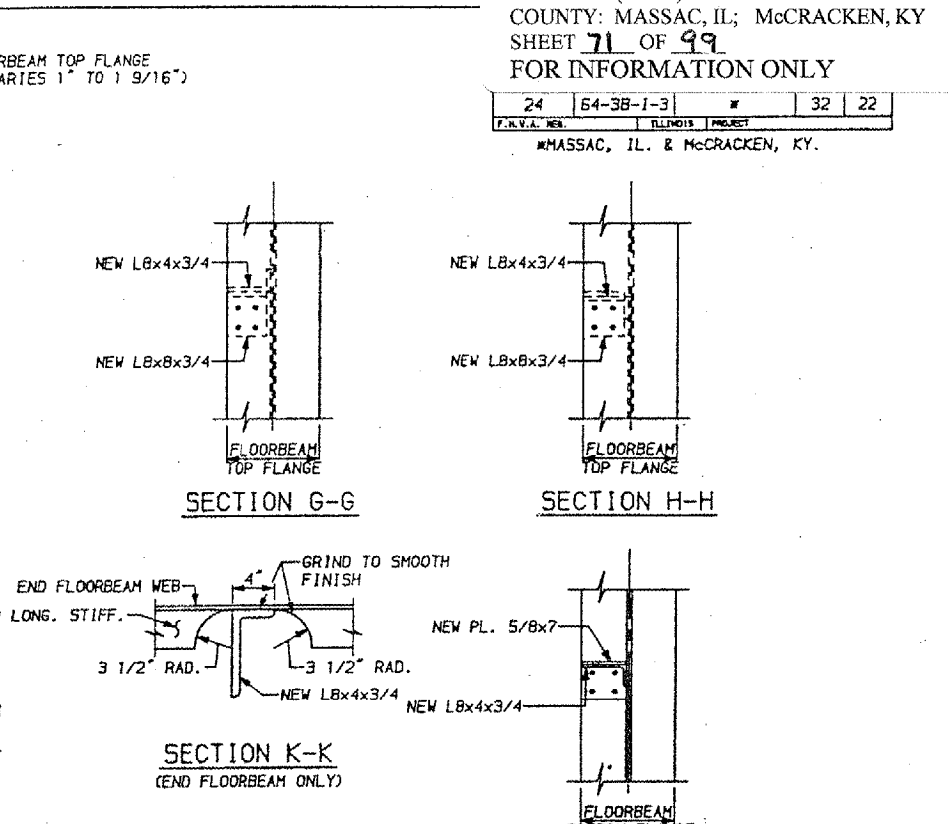

SECTION E - E

RETROFIT TYPE F6 AND TYPE F7

GENERAL PROCEDURE:

1. CUT VERTICAL STIFFENER ON BOTH SIDES OF THE FLOORBEAM AS SHOWN IN SECTION E - E. GRIND CUT SURFACE TO A SMOOTH FINISH.
2. SANDBLAST TO REMOVE PAINT FROM THE FLOORBEAM WEB AND TOP OF MANHOLE STIFFENER WITHIN 6" OF EACH SIDE OF CENTER LINE OF FLOORBEAM.
3. USE DYE PENETRANT TO CHECK THE FLOORBEAM WEB FOR CRACKS AT THE LOCATIONS SHOWN ON THE SHORT TRANSVERSE STIFFENER ABOVE THE ACCESS HOLE. IF THE WEB IS CRACKED, DRILL A 15/16" DIAMETER HOLE AT THE CRACK TIP AND DEBURR HOLE. USE DYE PENETRANT ON THE NEWLY EXPOSED (DRILLED) SURFACE OF THE FLOORBEAM WEB TO ENSURE THAT THE CRACK DOES NOT EXTEND PAST THE HOLE. IF THE CRACK EXTENDS PAST THE HOLE, GRIND TO REMOVE CRACK OR DRILL ANOTHER HOLE. REPEAT DYE PENETRANT CHECK. SOLVENT CLEAN TO REMOVE CUTTING OIL AND GREASE.
4. BLAST CLEAN TO REMOVE PAINT FROM FLOORBEAM WEB WITHIN AN AREA 6" IN DIAMETER AND CENTERED AT THE TOP OF THE EXISTING CUT SHORT TRANSVERSE STIFFENERS ON BOTH SIDES OF THE MANHOLE.
5. USE DYE PENETRANT TO CHECK THE FLOORBEAM WEB FOR CRACKS AT THE TOP OF THE EXISTING CUT SHORT TRANSVERSE STIFFENERS ON BOTH SIDES OF THE MANHOLE. IF THE WEB IS CRACKED, DRILL A 15/16" DIAMETER HOLE AT THE CRACK TIP AND DEBURR HOLE. USE DYE PENETRANT ON THE NEWLY EXPOSED (DRILLED) SURFACE OF THE FLOORBEAM WEB TO ENSURE THAT THE CRACK DOES NOT EXTEND PAST THE HOLE. IF THE CRACK EXTENDS PAST THE HOLE, GRIND TO REMOVE CRACK OR DRILL ANOTHER HOLE. REPEAT DYE PENETRANT CHECK. SOLVENT CLEAN TO REMOVE CUTTING OIL AND GREASE.
6. REPEAT STEPS 2, 3, 4 AND 5 FOR THE OPPOSITE SIDE OF THE FLOORBEAM WEB.
7. AT END FLOORBEAMS ONLY, CUT LONGITUDINAL STIFFENER AS SHOWN IN SECTION K-K. GRIND CUT SURFACE TO A SMOOTH FINISH.
- 8A. SECURE NEW VERTICAL STIFFENER ANGLES IN PLACE ON THE FLOORBEAM WEB SO THAT THE NEW ANGLE IS TIGHT AGAINST THE EXISTING WELDMENT (TYPE F6) OR SECURE NEW VERTICAL STIFFENER ANGLE AND PLATE SO THAT THE NEW PLATE IS TIGHT AGAINST THE BOTTOM FLANGE (TYPE F7). USING THE NEW ANGLE AND PLATE AS A TEMPLATE, DRILL HOLES IN FLOORBEAM WEB (TYPE F6 AND F7) AND IN THE BOTTOM FLANGE (TYPE F7 ONLY).

RETROFIT TYPE F6 AND TYPE F7

GENERAL PROCEDURE: (CONTINUED)

- 8B. REMOVE EXISTING VERTICAL STIFFENER ANGLES, SIMILAR TO EXISTING ANGLES SHOWN ON RETROFIT TYPE B, SHEET 21. SECURE NEW VERTICAL STIFFENER ANGLE AND PLATE SO THAT THE NEW PLATE FITS TIGHT AGAINST THE BOTTOM FLANGE (TYPE F7). USE EXISTING HOLES IN FLOORBEAM WEB AS A TEMPLATE TO DRILL HOLES IN NEW VERTICAL STIFFENER ANGLE. USE NEW PLATE AS A TEMPLATE TO DRILL HOLES IN THE BOTTOM FLANGE (TYPE F7).
9. REMOVE NEW ANGLES AND PLATES AND SOLVENT CLEAN FAYING SURFACES ON FLOORBEAM WEB AND BOTTOM FLANGE TO CLEAN AND REMOVE CUTTING OIL. ALSO SOLVENT CLEAN AND REMOVE CUTTING OIL FROM FAYING SURFACES ON NEW ANGLES AND PLATES. SANDBLAST FAYING SURFACES ON FLOORBEAM WEB AND FLANGES TO REMOVE PAINT.
10. PLACE ANGLES ON FLOORBEAM WEB AND INSTALL BOLTS (TYPE F6) OR PLACE ANGLES ON FLOORBEAM WEB AND PLATE ON BOTTOM FLANGE AND INSTALL BOLTS (TYPE F7).
11. SECURE NEW ANGLES AGAINST OUTSTANDING LEG OF NEW VERTICAL STIFFENER ANGLES AND TOP FLANGE. DRILL HOLES IN THE OUTSTANDING LEG OF NEW STIFFENER ANGLE AND TOP FLANGE USING NEW ANGLE AS A TEMPLATE.
12. REMOVE NEW ANGLES AND SOLVENT CLEAN FAYING SURFACES ON OUTSTANDING LEG OF NEW VERTICAL STIFFENER AND TOP FLANGE TO CLEAN AND REMOVE CUTTING OIL. ALSO SOLVENT CLEAN AND REMOVE CUTTING OIL FROM SURFACES OF NEW ANGLE.
13. POSITION NEW ANGLE ON FLOORBEAM AND INSTALL BOLTS.

RETROFIT TYPE F6 ONLY

14. SECURE NEW PLATE TO BOTTOM OF OUTSTANDING LEG OF NEW VERTICAL STIFFENER ANGLE AND TO OUTSTANDING LEG OF EXISTING CABLE CONNECTION WELDMENT. DRILL HOLES IN OUTSTANDING LEG OF NEW VERTICAL STIFFENER ANGLE AND OUTSTANDING LEG OF EXISTING CABLE CONNECTION WELDMENT USING THE NEW PLATE AS A TEMPLATE.

RETROFIT TYPE F6 AND TYPE F7

GENERAL PROCEDURE: (CONTINUED)

15. REMOVE NEW PLATE AND SOLVENT CLEAN FAYING SURFACES ON OUTSTANDING LEGS OF NEW VERTICAL STIFFENER ANGLE AND EXISTING CABLE CONNECTION WELDMENT TO CLEAN AND REMOVE CUTTING OIL. ALSO SOLVENT CLEAN AND REMOVE CUTTING OIL FROM FAYING SURFACE ON NEW PLATE. SANDBLAST FAYING SURFACE ON LEG OF EXISTING VERTICAL TO REMOVE PAINT.
16. PLACE NEW PLATE IN FINAL POSITION AND INSTALL NEW BOLTS.
17. PAINT ENTIRE RETROFIT AREA.

NOTES:

- FOR GENERAL NOTES SEE SHEET 3.
- FOR RETROFIT LOCATIONS SEE SHEET 18.
- ALL WORK SHALL BE DONE IN ACCORDANCE WITH THE SPECIAL PROVISIONS.
- DENOTES EXISTING 7/8" H.S. BOLT IN EXISTING HOLE.
- DENOTES NEW 7/8" H.S. BOLT IN NEW HOLE, EXCEPT AS NOTED.

QUANTITIES				
RETROFIT	ITEM	UNIT	UNIT II	UNIT V
TYPE F6	STRUCTURAL STEEL	LBS.	900	900
TYPE F7	STRUCTURAL STEEL	LBS.	3,900	5,000

PREPARED BY
MODJESKI AND MASTERS
 CONSULTING ENGINEERS

DRAWN: CMH
 CHKD: TBM
 APPD: JEP
 DATE: 10/11/88

REV. NO.	DRAWN	CHKD.	APPD.	DESCRIPTION	DATE

**F A 1 ROUTE 24 (INTERSTATE 24)
 OVER OHIO RIVER
 MASSAC COUNTY ILLINOIS**

RETROFIT DETAILS 4

24	64-3B-1-3	*	32	29
ILLINOIS PROJECT		KANSAS PROJECT		
MASSAC, IL. & McCRACKEN, KY.				

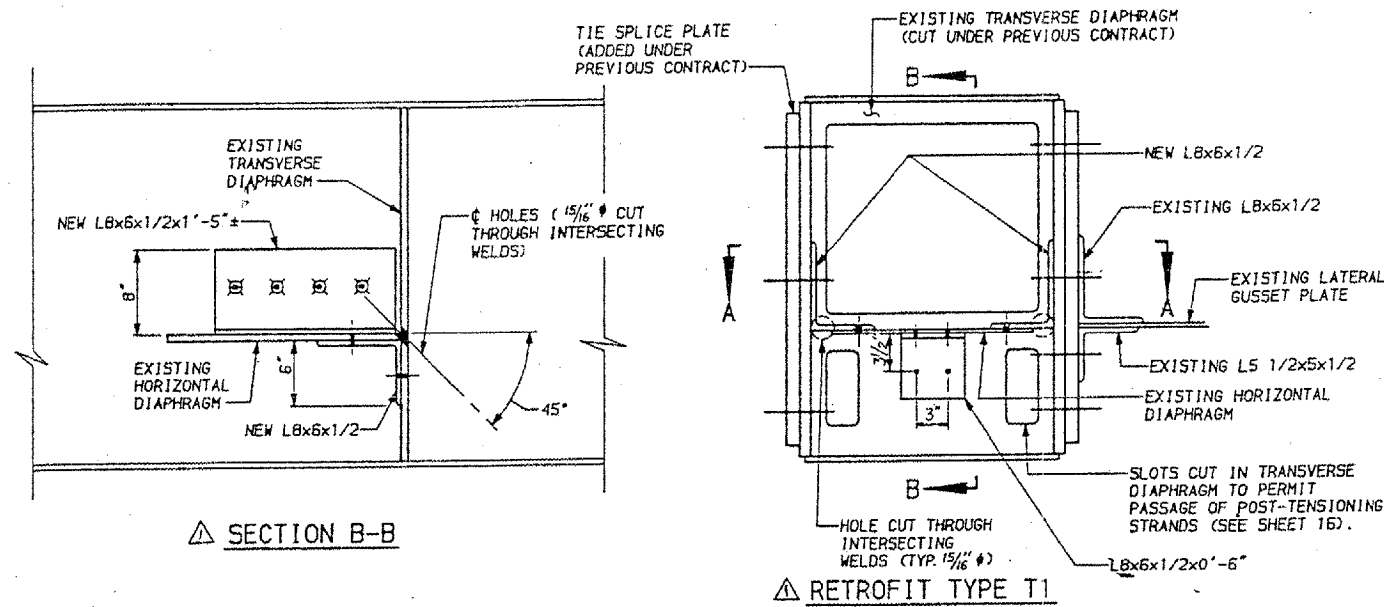

RETROFIT TYPE T1

GENERAL PROCEDURE

1. REMOVE EXISTING BOLTS FROM TIE WEB PLATES AT LOCATIONS SHOWN ON DETAIL TO PERMIT PLACEMENT OF NEW ANGLES.
2. SECURE NEW ANGLES TO TIE WEB AND TRANSVERSE DIAPHRAGM SO THAT THE HORIZONTAL LEG IS TIGHT AGAINST THE HORIZONTAL DIAPHRAGM. USE EXISTING HOLES IN WEB AS A TEMPLATE TO DRILL HOLES IN NEW ANGLE. USE NEW ANGLE AS A TEMPLATE TO DRILL NEW HOLES IN THE HORIZONTAL AND TRANSVERSE DIAPHRAGMS.
3. CUT 1 5/16" Ø HOLES AS CLOSE AS POSSIBLE TO THE INTERSECTION OF THE HORIZONTAL DIAPHRAGM PLATE AND TRANSVERSE DIAPHRAGM PLATE ADJACENT TO THE TIE WEB PLATE. GRIND EDGES OF HOLES AS REQUIRED TO REMOVE THE INTERSECTIONS OF THE HORIZONTAL DIAPHRAGM-TO-WEB WELD, THE TRANSVERSE DIAPHRAGM-TO-WEB WELD, AND HORIZONTAL DIAPHRAGM-TO-TRANSVERSE DIAPHRAGM WELD. GRINDING SHALL NOT NICK OR GOUGE TIE WEB PLATES.
4. REMOVE THE HORIZONTAL DIAPHRAGM PLATE BY CUTTING THE PLATE AS CLOSE TO THE WEB AND TRANSVERSE DIAPHRAGM PLATES AS POSSIBLE WITHOUT NICKING, GOUGING, OR OVERHEATING THE WEB PLATES.
5. GRIND TO REMOVE THE WELD MATERIAL REMAINING ON THE WEB PLATES. WEB PLATES SHOULD BE GRIND TO A SMOOTH FINISH AND BE FULL-THICKNESS (ANSI 125 MIN.)
6. USE A POWER TOOL TO REMOVE PAINT FROM THE TOP FACE OF THE HORIZONTAL DIAPHRAGM PLATE AND FROM THE INSIDE FACE OF THE TIE WEB PLATES. PAINT SHOULD BE REMOVED FROM THE WEB PLATES FROM THE LOCATION OF THE HORIZONTAL DIAPHRAGM PLATE TO APPROXIMATELY 10 INCHES ABOVE THE DIAPHRAGM BY THE ENTIRE LENGTH OF THE HORIZONTAL DIAPHRAGM. PAINT SHOULD ALSO BE REMOVED FROM THE TOP OF THE HORIZONTAL DIAPHRAGM PLATE APPROXIMATELY 10 INCHES FROM THE WEB BY THE ENTIRE LENGTH OF THE HORIZONTAL DIAPHRAGM PLATE. REMOVE PAINT FROM THE BOTTOM FACE OF THE HORIZONTAL DIAPHRAGM PLATE APPROXIMATELY 4 INCHES LEFT AND RIGHT OF CENTERLINE TIE AND 10 INCHES OUT FROM THE TRANSVERSE DIAPHRAGM. REMOVE PAINT FROM TRANSVERSE DIAPHRAGM APPROXIMATELY 8 INCHES FROM THE BOTTOM OF THE HORIZONTAL DIAPHRAGM AND 4 INCHES LEFT AND RIGHT OF CENTERLINE.
7. USE DYE PENETRANT TO CHECK THE TIE WEB PLATES FOR CRACKS IN THE AREA WHERE THE HORIZONTAL DIAPHRAGM PLATE HAD BEEN WELDED TO THE WEB. IF A CRACK EXISTS, REMOVE CRACK BY GRINDING. ALL CRACKS IDENTIFIED SHOULD BE REPORTED TO THE ENGINEER.
8. USE A CHEMICAL CLEANING AGENT TO REMOVE DYE PENETRANT, CUTTING OIL AND OTHER DEBRIS FROM THE FAYING SURFACES ON THE WEB PLATES, THE TRANSVERSE DIAPHRAGM, THE HORIZONTAL DIAPHRAGM AND THE NEW ANGLES.
9. RE-INSTALL HORIZONTAL DIAPHRAGM WITH THREE NEW ANGLES AS SHOWN IN THE DETAIL.
10. PAINT ENTIRE RETROFIT AREA.

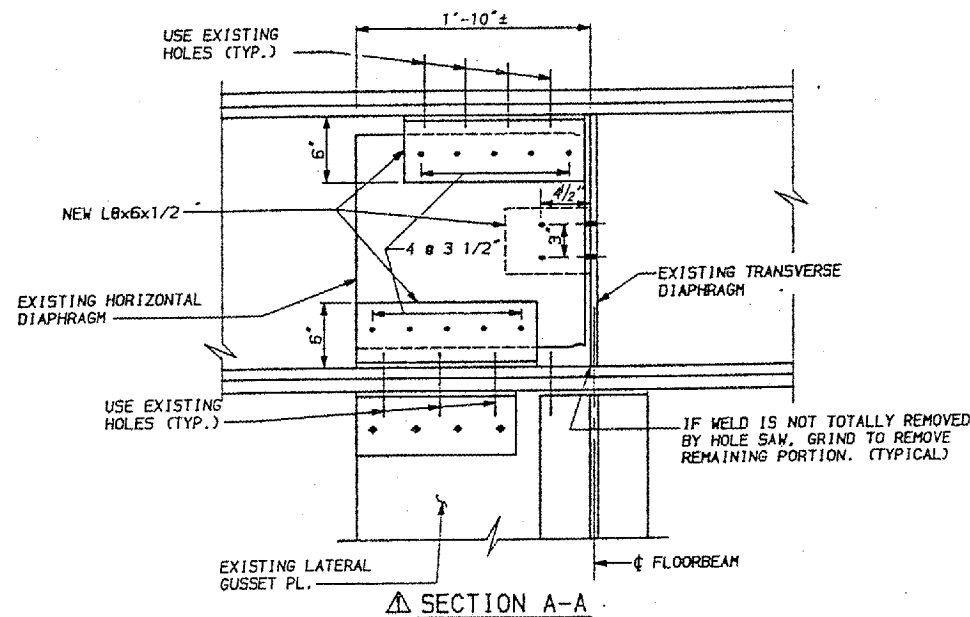

NOTES:

- FOR GENERAL NOTES, SEE SHEET 3.
 FOR RETROFIT LOCATIONS, SEE SHEET 18.
 ALL WORK SHALL BE DONE IN ACCORDANCE WITH THE SPECIAL PROVISIONS.
- ♦ DENOTES EXISTING 7/8" Ø H.S. BOLT IN EXISTING HOLE.
 - DENOTES NEW 7/8" Ø H.S. BOLT IN NEW HOLES.
 - ⊠ DENOTES NEW 1 1/4" Ø H.S. BOLT (AASHTO M 253) IN EXISTING HOLE.

REV. NO.	DATE	BY	CHKD.	APPD.	DESCRIPTION	DATE
1	10/24/88	SLH	REM	JEP	MISCELLANEOUS	10/24/88

**F A I ROUTE 24 (INTERSTATE 24)
 OVER OHIO RIVER
 MASSAC COUNTY ILLINOIS**

ARCH TIE RETROFIT

PREPARED BY
MODJESKI AND MASTERS
 CONSULTING ENGINEERS

QUANTITIES				
RETROFIT	ITEM	UNIT	UNIT II	UNIT V
TYPE T1	STRUCTURAL STEEL	LBS.	2,500	3,100

DRAWN: DTP
 CHKD: TBM
 APPD: JEP
 DATE: 10/11/88

D.W. 064-0035

164

97.0%
9-2-91

FOR INDEX OF SHEETS, SEE SHEET NO. 2
FOR SUMMARY OF QUANTITIES, SEE SHEET NO. 2

STATE OF ILLINOIS
DEPARTMENT OF TRANSPORTATION
DIVISION OF HIGHWAYS
**PLANS FOR PROPOSED
FEDERAL AID INTERSTATE HIGHWAY
DISTRICT 9
F.A.I. 24
SECTION 64-3B-I-4
MASSAC COUNTY, IL. & McCRACKEN COUNTY, KY.
C-99-053-95**

CONTRACT: 98990
ROUTE: INTERSTATE 24
SECTION: (64-3B) I-6
COUNTY: MASSAC, IL.; McCRACKEN, KY
SHEET **73** OF **99**
FOR INFORMATION ONLY

24	64-3B-I-4	MASSAC	11	1
SHEET NO.		PROJECT		ILLINOIS

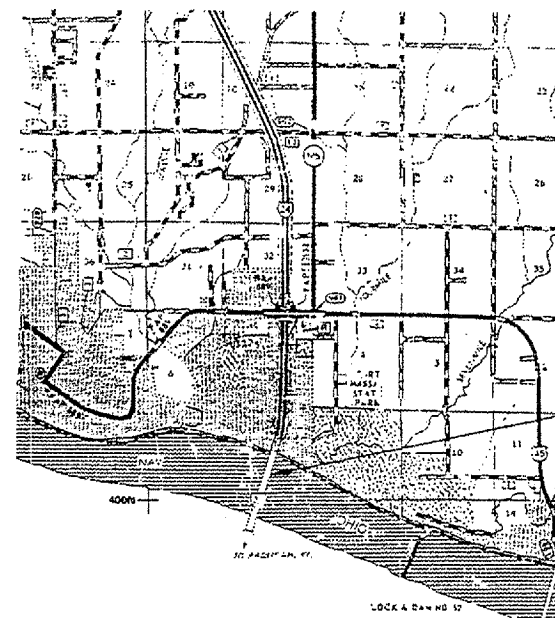
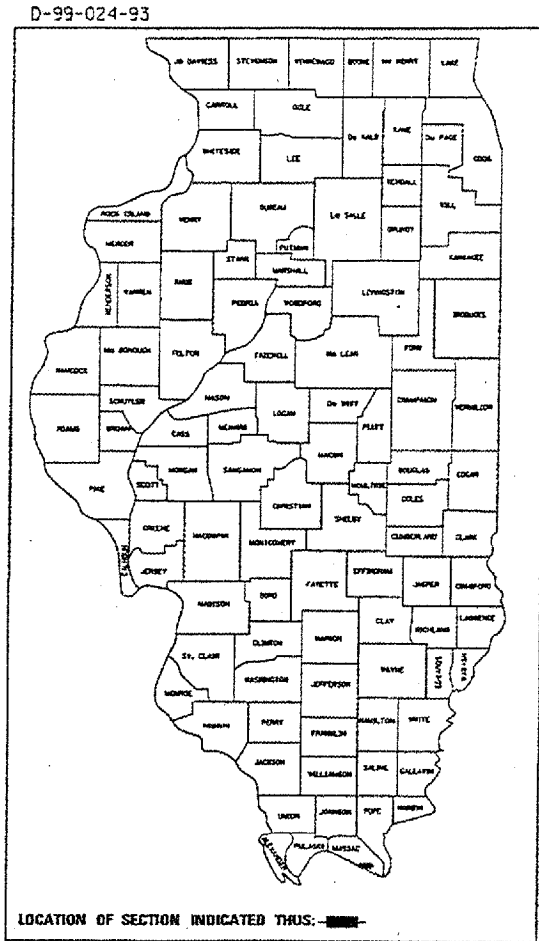

JULIE 1-800-892-0123

TOWNSHIP: METROPOLIS
TRAFFIC DATA: ADT = 24,500
NET LENGTH OF PROJECT = 5,634 FT. = 1.07 MI.

064-0035
CONTRACT NO. 98344

STATE OF ILLINOIS
DEPARTMENT OF TRANSPORTATION
DIVISION OF HIGHWAYS

SUBMITTED Feb 8 1996
[Signature]
DISTRICT ENGINEER

EXAMINED _____ 19____
[Signature]
ENGINEER OF PLANS AND CONTRACTS

PASSED March 15 1996
[Signature]
ENGINEER OF DESIGN AND ENVIRONMENT

APPROVED March 15 1996
[Signature]
DIRECTOR, DIVISION OF HIGHWAYS

PRINTED BY THE AUTHORITY
OF THE STATE OF ILLINOIS

9-153

STATE OF ILLINOIS
DEPARTMENT OF TRANSPORTATION

CONTRACT: 98990
ROUTE: INTERSTATE 24
SECTION: (64-3B) 1-6
COUNTY: MASSAC, IL; McCRACKEN, KY
SHEET 74 OF 99
FOR INFORMATION ONLY

P.A.I. 24	64-3B-1-3	MASSAC	11	7	5 SHEETS
DESIGNED	CHECKED	DRAWN	CHECKED	DATE	BY

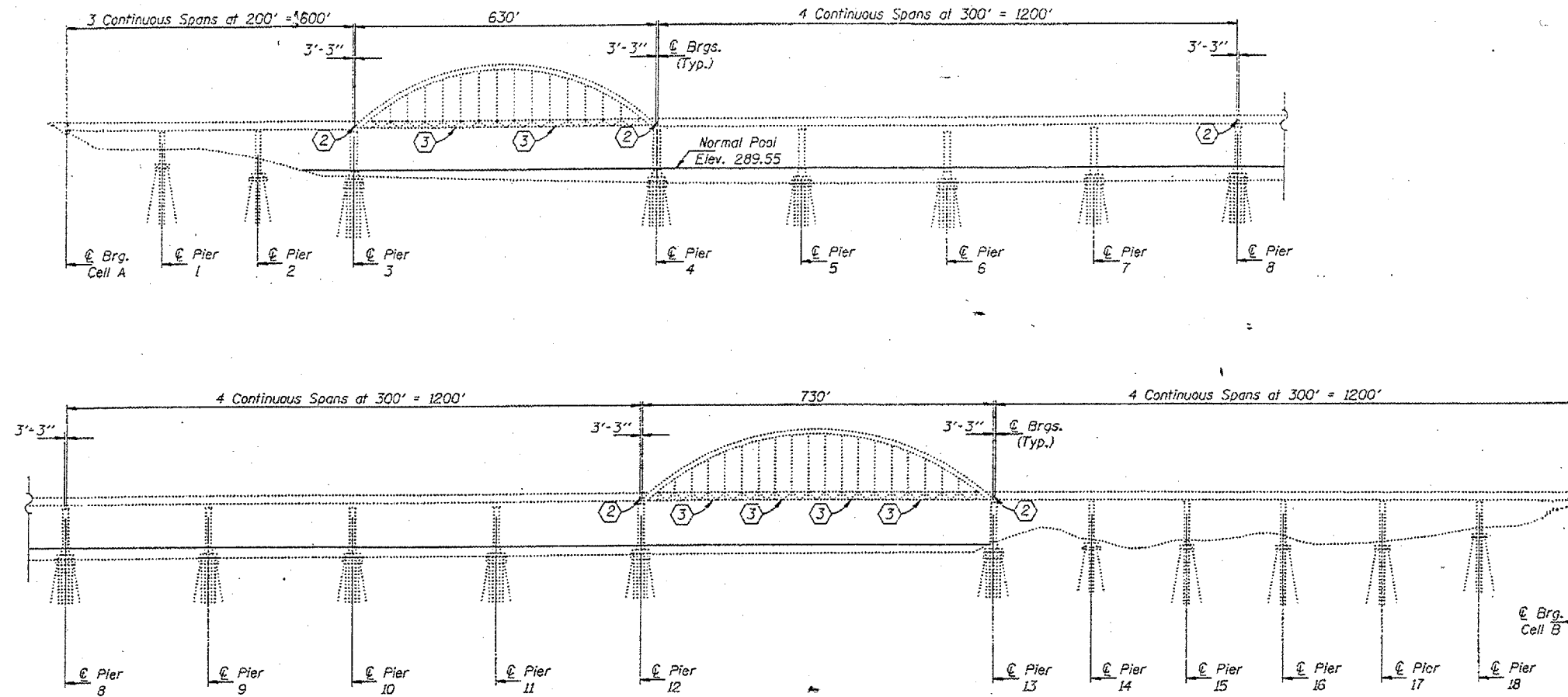

ELEVATION

Notes:

- ② Install new catch drains, elastomeric trough and carrier R's. Existing 3/8" R's to remain in place, to be cleaned and painted.
- ③ Remove existing 2 1/2" PJS and replace with new 2 1/2" PJS. (Removal shall be incidental to Preformed Joint Seal 2 1/2".)

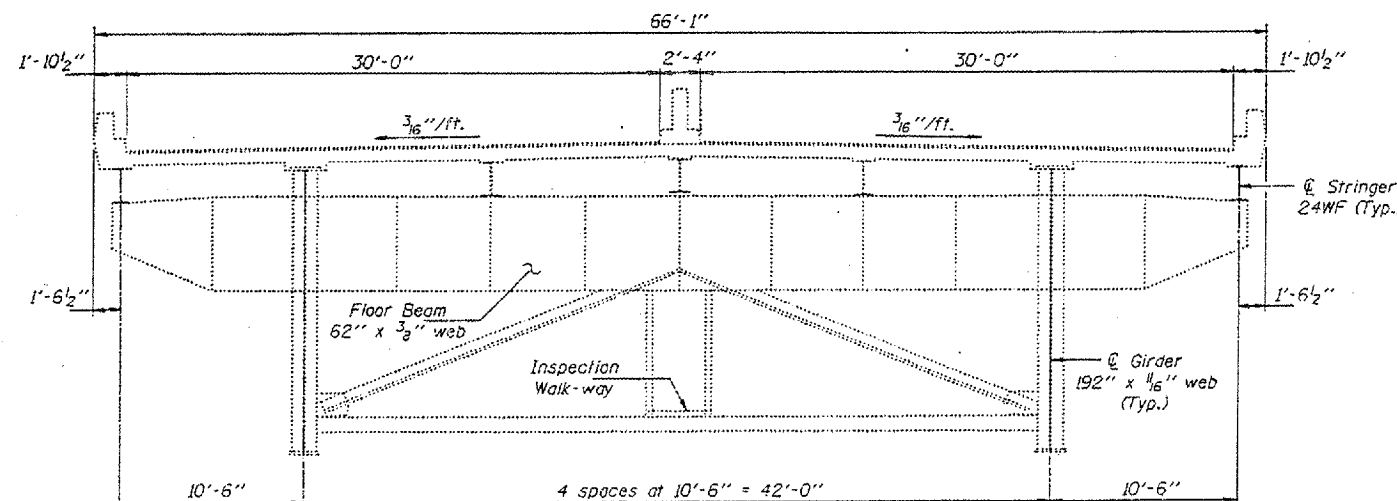

TYPICAL SECTION

TOTAL BILL OF MATERIAL

ITEM	UNIT	QUANTITY
Furnishing and Erecting Structural Steel	Pound	17,620
Traffic Control	L.S.	1
Reinf. Neoprene Expansion Jt. Treatment	Lin. Ft.	305
Preformed Joint Seal 2 1/2"	Lin. Ft.	402
* PROTECTO WRAP WATERPROOFING MEMBRANE SYSTEM	Sq. Yd.	37,562

* See Sheet 4 of 11 for details.

BRIDGE REPAIRS
F.A.I. 24 OVER OHIO RIVER
SEC. 64-3B-1-3
MASSAC COUNTY
S.N. 064-0035

DESIGNED	<i>Henneth P. Stults</i>
CHECKED	<i>Nicholas J. Dorsett</i>
DRAWN	<i>Dierbert</i>
CHECKED	<i>KPS</i>

FEBRUARY 29 19 96
EXAMINED *Joseph E. Amico*
ENGINEER OF STRUCTURAL SERVICES
PASSED
ENGINEER OF BRIDGES AND STRUCTURES

F.A.I. 24	3B-1-6	MASSAC	11	8	5 SHEETS
-----------	--------	--------	----	---	----------

STATE OF ILLINOIS
 DEPARTMENT OF TRANSPORTATION

*** Sealant applicable to Structural Steel. Cost incidental to Furnishing & Erecting Structural Steel.

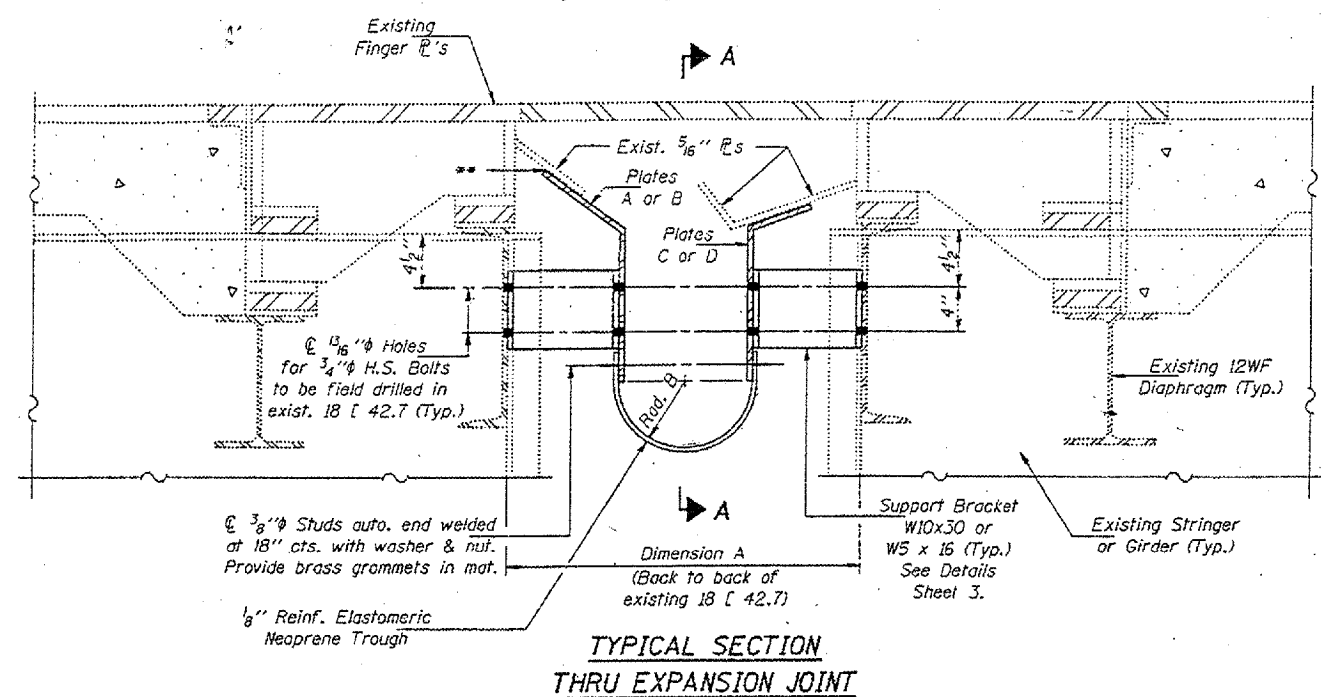
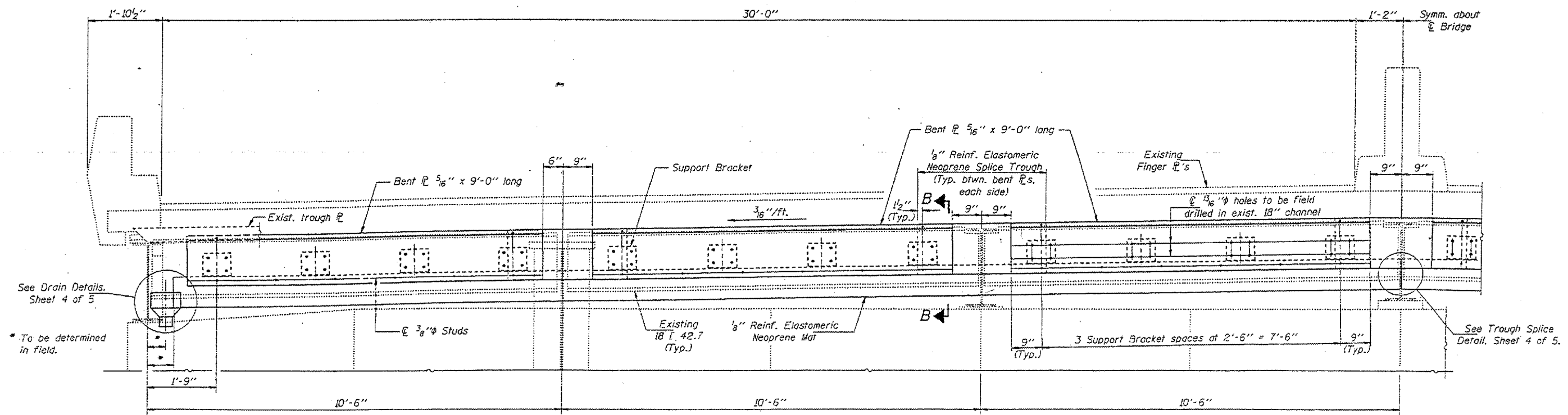

TABLE OF DIMENSIONS

LOCATION	DIMENSION AT TEMPERATURE (F.)										SUPPORT BRACKET SIZE
	20°		40°		60°		80°		100°		
	Dim. A	Rad. B	Dim. A	Rad. B	Dim. A	Rad. B	Dim. A	Rad. B	Dim. A	Rad. B	
Pier #3	2'-7 1/8"	5 1/16"	2'-5 1/16"	4 7/8"	2'-4 1/4"	3 5/8"	2'-2 13/16"	2 5/16"	2'-1 5/16"	2 3/16"	W10x30
Pier #4	1'-7 1/8"	4 3/16"	1'-6 7/16"	4 1/4"	1'-5 3/4"	3 7/8"	1'-5 1/16"	3 9/16"	1'-4 5/16"	3 3/16"	W5x16
Pier #8	3'-2 3/4"	8 7/8"	3'-0 3/8"	7 1/16"	2'-10"	6 1/2"	2'-7 5/8"	5 5/16"	2'-5 9/16"	4 1/8"	W10x30
Pier #12	3'-0 1/16"	7 7/8"	2'-10 1/8"	6 5/16"	2'-9"	6"	2'-7 7/8"	5 1/16"	2'-5 5/16"	4 1/8"	W10x30
Pier #13	1'-9 3/8"	5 13/16"	1'-8 9/16"	5 3/8"	1'-7 3/4"	4 7/8"	1'-6 13/16"	4 7/16"	1'-5 7/8"	3 5/16"	W5x16

Notes: For Section B-B, see sheet 4.



DESIGNED	KPS	FEBRUARY 29	1996
CHECKED	NJS	EXAMINED	<i>John E. Adams</i>
DRAWN	D-herbert	PASSED	
CHECKED	NJS KPS		

ENGINEER OF BRIDGES AND STRUCTURES

SECTION A-A
 (R C or D shown,
 R A or B similar)

BRIDGE REPAIRS
 F.A.I. 24 OVER OHIO RIVER
 SEC. 64-3B-1-3
 MASSAC COUNTY
 S.N. 064-0035

F.A.I. 24	EX-3B-1-3	MASSAC	11	9	5 SHEETS
FED. ROAD DIST. NO. 7		ILLINOIS	FED. RD. PROJECT		

STATE OF ILLINOIS
 DEPARTMENT OF TRANSPORTATION

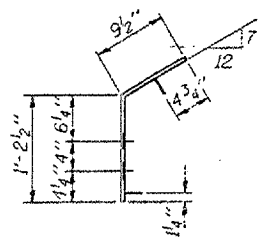
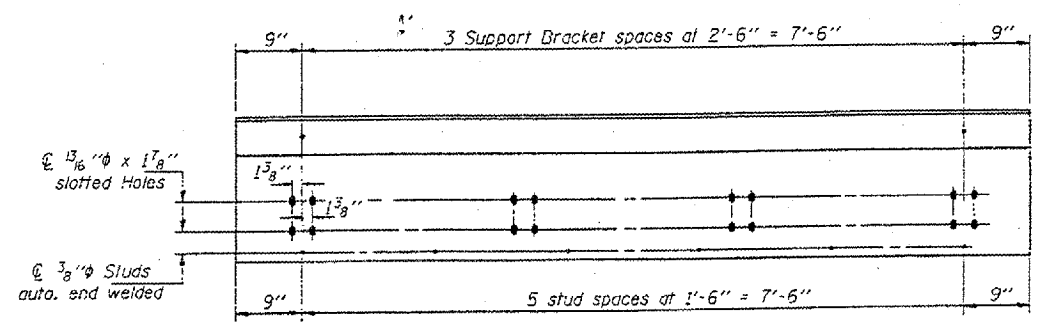

END VIEW

PLATE A

Pl. 5/16" x 2'-0" x 9'-0" long
 (At Piers 3, 8 & 12)
 Number Req'd: 18 Total

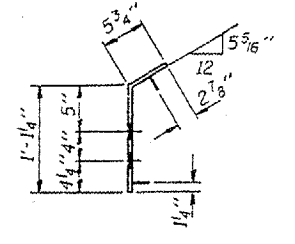
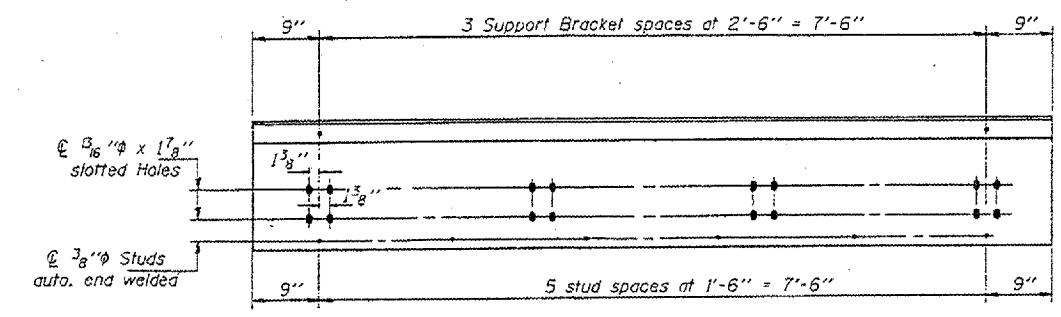

END VIEW

PLATE C

Pl. 5/16" x 1'-7" x 9'-0" long
 (At Piers 3, 8 & 12)
 Number Req'd: 18 Total

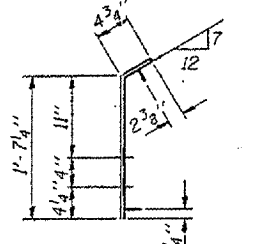
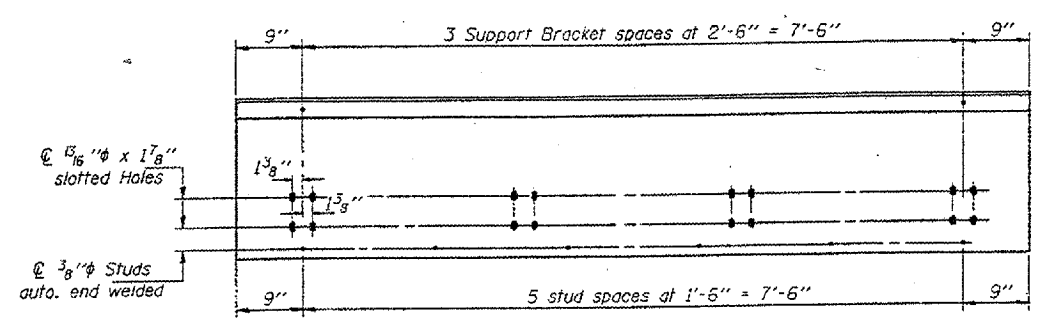

END VIEW

PLATE B

Pl. 5/16" x 2'-0" x 9'-0" long
 (At Piers 4 & 13)
 Number Req'd: 12 Total

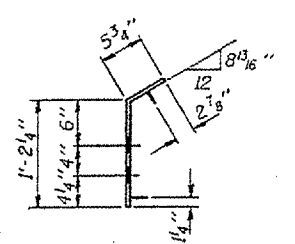
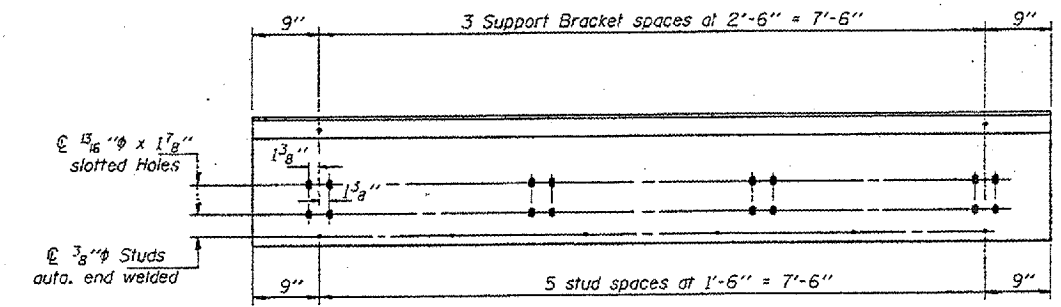

END VIEW

PLATE D

Pl. 5/16" x 1'-8" x 9'-0" long
 (At Piers 4 & 13)
 Number Req'd: 12 Total

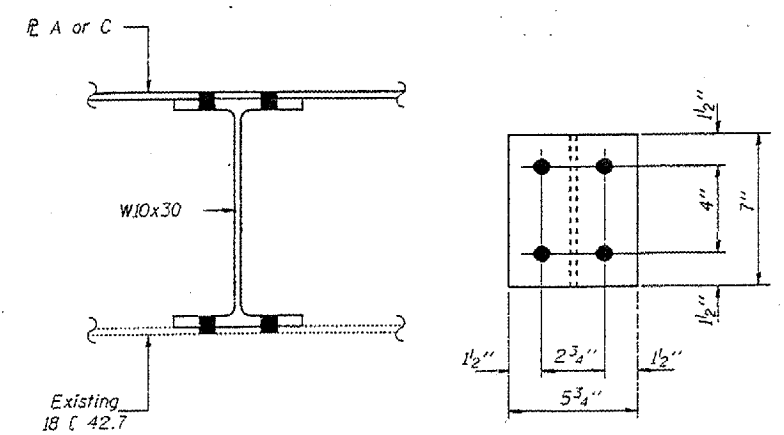

SUPPORT BRACKET
 W10x30
 (At Piers 3, 8 & 12)
 Number Req'd: 144 Total

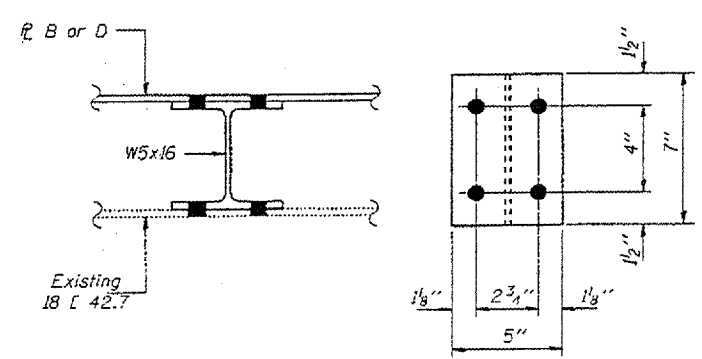

SUPPORT BRACKET
 W5x16
 (At Piers 4 & 13)
 Number Req'd: 96 Total

DESIGNED	KPS	FEBRUARY 29	1996
CHECKED	NJS	EXAMINED	<i>Scott E. Adams</i>
DRAWN	D-herbert	PASSED	
CHECKED	NJS KPS	ENGINEER OF BRIDGES AND STRUCTURES	

BRIDGE REPAIRS
 F.A.I. 24 OVER OHIO RIVER
 SEC. 64-3B-I-3
 MASSAC COUNTY
 S.N. 064-0035

STATE OF ILLINOIS
 DEPARTMENT OF TRANSPORTATION

DATE	F.A.I. 24	54-36-1-3	MASSAC	11	10	3 SHEETS
ILLINOIS DEPT. OF TRANSPORTATION	ILLINOIS	PER. AND PROJECT				

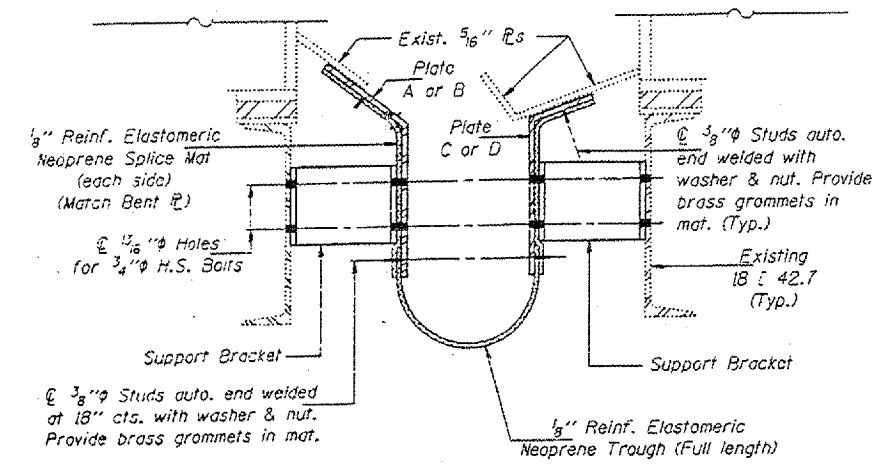

SECTION B-B

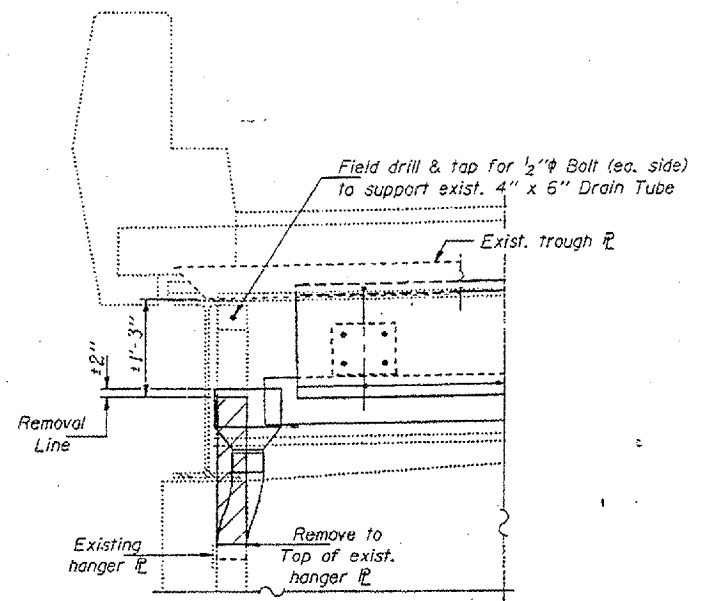

DRAIN TUBE REMOVAL DETAILS

Hatched area indicates removal of existing 4" x 6" drain tube. (Typ. each end)

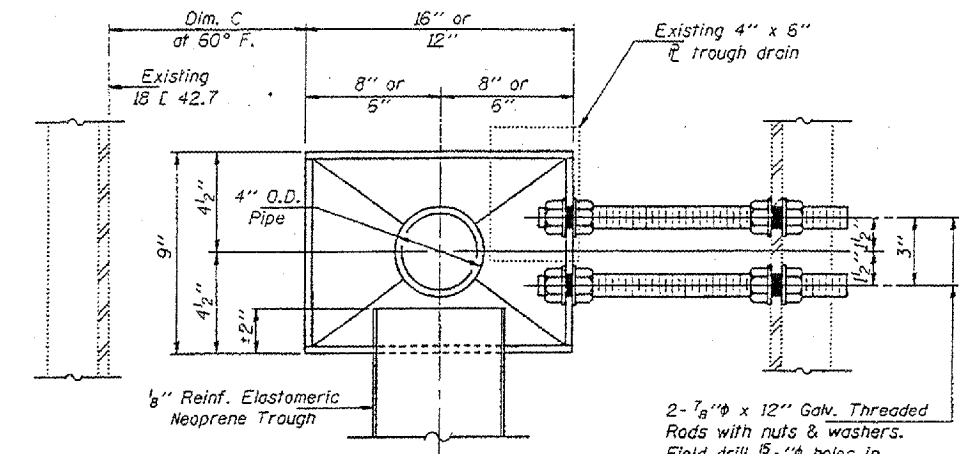

TOP VIEW

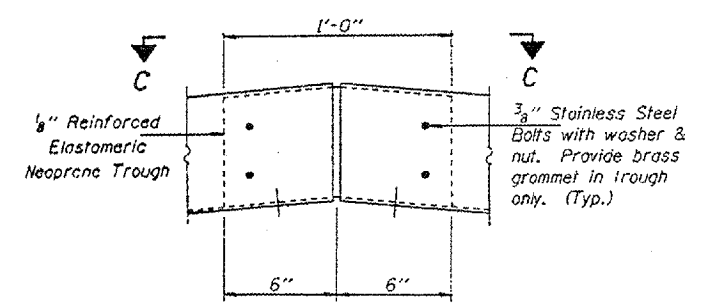

TROUGH SPLICE DETAIL

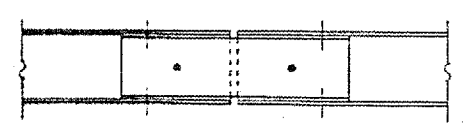

VIEW C-C

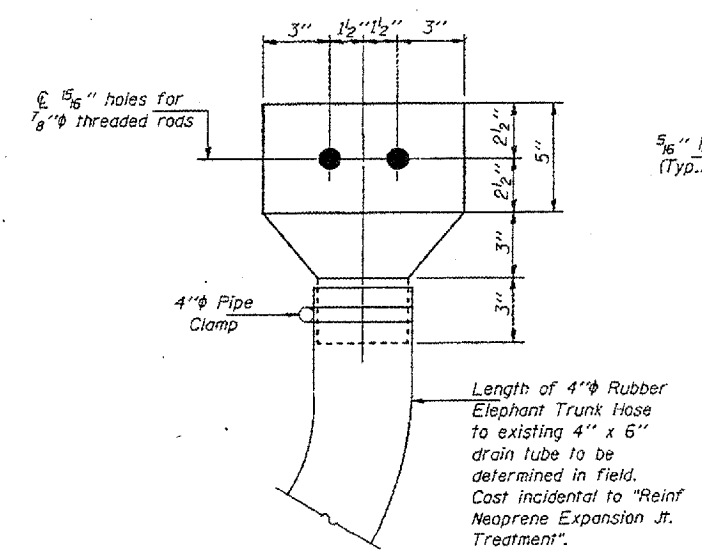

VIEW D-D

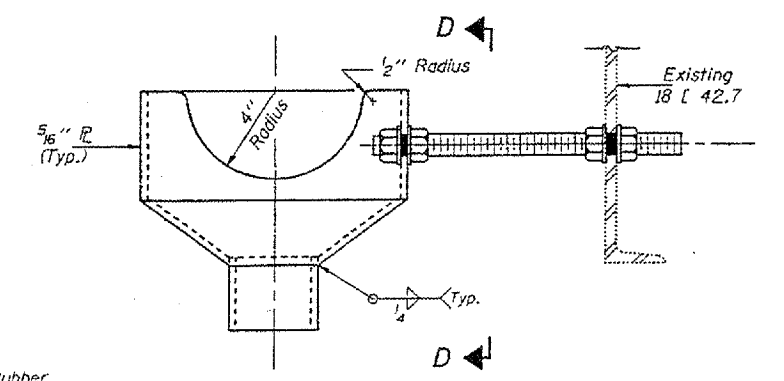

ELEVATION

(Looking out from @ Bridge)
 Piers 3, 4, 8, & 12 shown;
 Pier 13 similar except opposite hand

LOCATION	DRAIN SIZE	Dim. C
Pier #3	9" x 16"	6"
Pier #4	9" x 12"	3"
Pier #8	9" x 16"	8"
Pier #12	9" x 16"	7"
Pier #13	9" x 12"	3"

DRAIN DETAILS

Total No. Req'd.:
 9" x 16" = 6
 9" x 12" = 4

TROUGH & DRAIN DETAILS
 F.A.I. 24 OVER OHIO RIVER
 SEC. 64-3B-I-3
 MASSAC COUNTY
 S.N. 064-0035

DESIGNED	KPS	FEBRUARY 29	1996
CHECKED	NJS	EXAMINED	Joseph E. Adams
DRAWN	Dierbert	ENGINEER OF STRUCTURAL SERVICES	
CHECKED	NJS KPS	PASSED	
		DEPARTMENT OF BRIDGES AND STRUCTURES	

CONTRACT: 98990
 ROUTE: INTERSTATE 24
 SECTION: (64-3B) I-6
 COUNTY: MASSAC, IL; McCracken, KY
 SHEET 78 OF 99
 FOR INFORMATION ONLY

F.A.I. 24	64-3B-I-3	MASSAC	11	11	5 SHEETS
FED. ROAD DIST. NO. 7		SHEET NO.		TOTAL SHEETS	

STATE OF ILLINOIS
 DEPARTMENT OF TRANSPORTATION

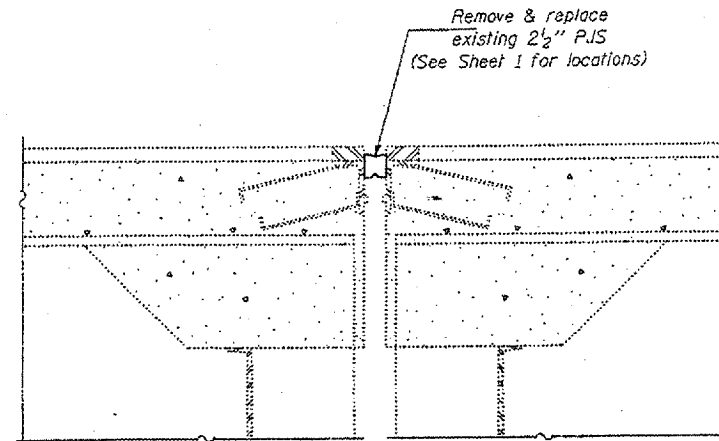

SECTION THRU PJS JOINTS

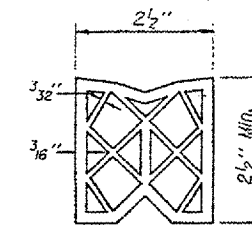

2 1/2\"/>

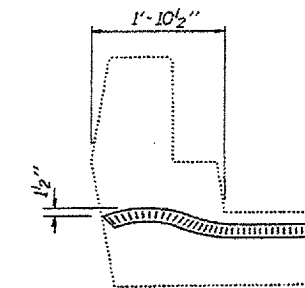

END OF SEAL TREATMENT

DESIGNED	KPS	FEBRUARY 29	1996
CHECKED	NJS	EXAMINED	<i>Joseph E. Adams</i> ENGINEER OF STRUCTURAL SERVICES
DRAWN	Dierbart	PASSED	
CHECKED	NJS KPS		ENGINEER IN CHARGE AND SUPERVISOR

BRIDGE REPAIRS
F.A.I. 24 OVER OHIO RIVER
SEC. 64-3B-I-3
MASSAC COUNTY
S.N. 064-0035

257

STATE OF ILLINOIS
DEPARTMENT OF TRANSPORTATION
DIVISION OF HIGHWAYS

PROPOSED
HIGHWAY PLANS

F.A.I. ROUTE 24 (I-24)
SECTION 64-3B-1-5
C-99-030-03

MASSAC COUNTY, ILLINOIS
McCRACKEN COUNTY, KENTUCKY

FOR INDEX OF SHEETS, SEE SHEET NO. 2
FOR SUMMARY OF QUANTITIES, SEE SHEET NO. 2

ILLINOIS TOWNSHIP: METROPOLIS
2002 ADT = 26,400
POSTED SPEED = 65 MPH
INVENTORY RATING HS 20.0
OPERATING RATING HS 30.0

CONTRACT: 98990
ROUTE: INTERSTATE 24
SECTION: (64-3B) I-6
COUNTY: MASSAC, IL; McCRACKEN, KY
SHEET 99 OF 99
FOR INFORMATION ONLY

D-99-028-01

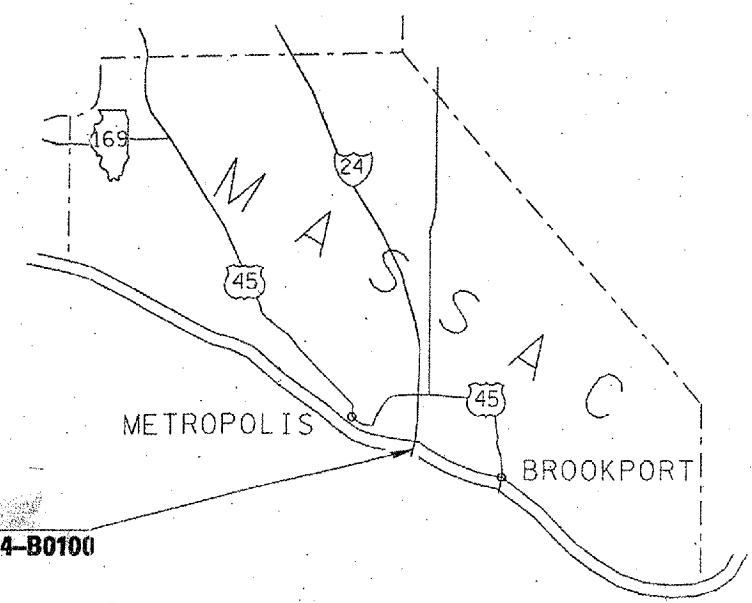
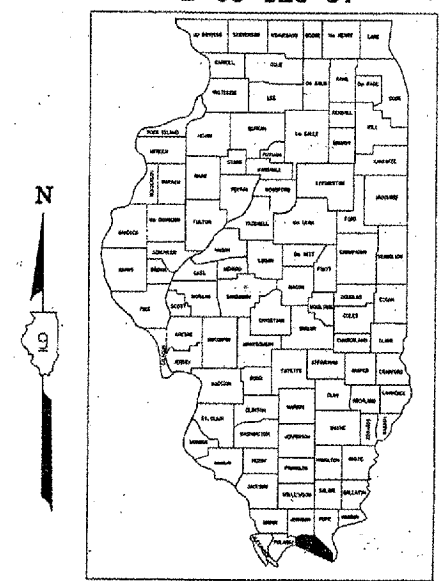

PROPOSED IMPROVEMENT
ILLINOIS STRUCTURE NO. 064-0035
KENTUCKY STRUCTURE NO. 073-0024-B0100
STRUCTURAL STEEL REPAIR

STATE OF ILLINOIS
DEPARTMENT OF TRANSPORTATION
DIVISION OF HIGHWAYS
SUBMITTED Nov 9, 20 02
[Signature]
DISTRICT ENGINEER
May 9, 20 03
[Signature]
ENGINEER OF DESIGN AND ENVIRONMENT
May 9, 20 03
[Signature]
DIRECTOR, DIVISION OF HIGHWAYS

PROJECT ENGINEER: KAREN RICHARDSON PHONE: (618) 549-2171
SQUAD LEADER: RITA GAUTNEY CENTREX: 782-4554

PLAN DRAWINGS ARE NOT TO SCALE.
J.U.L.I.E.
JOINT UTILITY LOCATION INFORMATION FOR EXCAVATION
1-800-892-0123

MAP NOT TO SCALE
STRUCTURE LENGTH: 5,634 FT.

CONTRACT NO. 98794

PRINTED BY THE AUTHORITY
OF THE STATE OF ILLINOIS

STATE OF ILLINOIS
DEPARTMENT OF TRANSPORTATION

CONTRACT: 98990
ROUTE: INTERSTATE 24
SECTION: (64-3B) I-6
COUNTY: MASSAC, IL; McCRACKEN, KY
SHEET 80 OF 99
FOR INFORMATION ONLY

SUMMARY OF QUANTITIES

CONSTRUCTION TYPE CODE: SFTY-2A		50% ILLINOIS 50% KENTUCKY	
CODE NO.	ITEM DESCRIPTION	UNIT	QUANTITY
X5005700	FLOATING BEARINGS, GUIDED EXPANSION, 700 K	EACH	4
X0322556	STIFFENER INTERSECTION MODIFICATION	EACH	1055
X0323392	POST-TENSION CABLE RETROFIT	EACH	912
Z0031200	JACKING AND CRIBBING	EACH	4
50104710	REMOVAL OF EXISTING BEARINGS	EACH	4
50300225	CONCRETE STRUCTURES	CU. YD.	3.4
50501130	STRUCTURAL STEEL REPAIR	POUND	11,070
50800205	REINFORCEMENT BARS, EPOXY COATED	POUND	450
70100205	TRAFFIC CONTROL AND PROTECTION STANDARD 701401	EACH	1
67000400	ENGINEER'S FIELD OFFICE, TYPE A	CAL. MO.	9
67100100	MOBILIZATION	L. SUM	1
70100700	TRAFFIC CONTROL AND PROTECTION STANDARD 701406	L. SUM	1
X7015000	CHANGEABLE MESSAGE SIGN	CAL. MO.	10

INDEX OF SHEETS

SHEET NO.	DESCRIPTION
1	COVER SHEET, SIGNATURES
2	INDEX OF SHEETS, SUMMARY OF QUANTITIES, STANDARDS
3	GENERAL NOTES, TOTAL BILL OF MATERIAL, STRUCTURE ELEVATION,
4-11	FRAMING PLANS
12	ANGLE LOCATION TABLES AND MISCELLANEOUS DETAILS
13	REPAIR DETAILS "A" AND "B" AND MISCELLANEOUS DETAILS
14	REPAIR DETAIL "C" AND "D"
15	REPAIR DETAILS "E" AND "F"
16	REPAIR DETAIL "G" AND "H"
17	REPAIR DETAIL "I" AND "J"
18	REPAIR DETAILS "K" AND "L"
19	REPAIR DETAILS "M" AND "N"
20	REPAIR DETAIL "P"
21	REPAIR DETAILS "Q"-ABUTMENT BEARINGS
22	REPAIR DETAIL "Q"-BEARING DETAILS
23	REPAIR DETAIL "R"
24	ANCHOR BOLT DETAILS

STANDARDS

701101
701401
701406-02
702001-03

DESIGNED	
CHECKED	
DRAWN	RKG
CHECKED	CNT

PREPARED BY:	<i>[Signature]</i> DISTRICT STUDIES & PLANS ENGINEER
EXAMINED BY:	<i>[Signature]</i> DISTRICT LAND ACQUISITION ENGINEER
EXAMINED BY:	<i>[Signature]</i> DISTRICT PROGRAM DEVELOPMENT ENGINEER
EXAMINED BY:	<i>[Signature]</i> DISTRICT OPERATIONS ENGINEER
EXAMINED BY:	<i>[Signature]</i> DISTRICT CONSTRUCTION ENGINEER
EXAMINED BY:	<i>[Signature]</i> DISTRICT MATERIALS ENGINEER
EXAMINED BY:	<i>[Signature]</i> DISTRICT PROJECT IMPLEMENTATION ENGINEER
APPROVED BY:	<i>[Signature]</i> DISTRICT ENGINEER
DATE	11-4 2002

STATE OF ILLINOIS
DEPARTMENT OF TRANSPORTATION

CONTRACT: 98990
ROUTE: INTERSTATE 24
SECTION: (64-3B) I-6
COUNTY: MASSAC, IL; McCRACKEN, KY
SHEET 81 OF 99
FOR INFORMATION ONLY

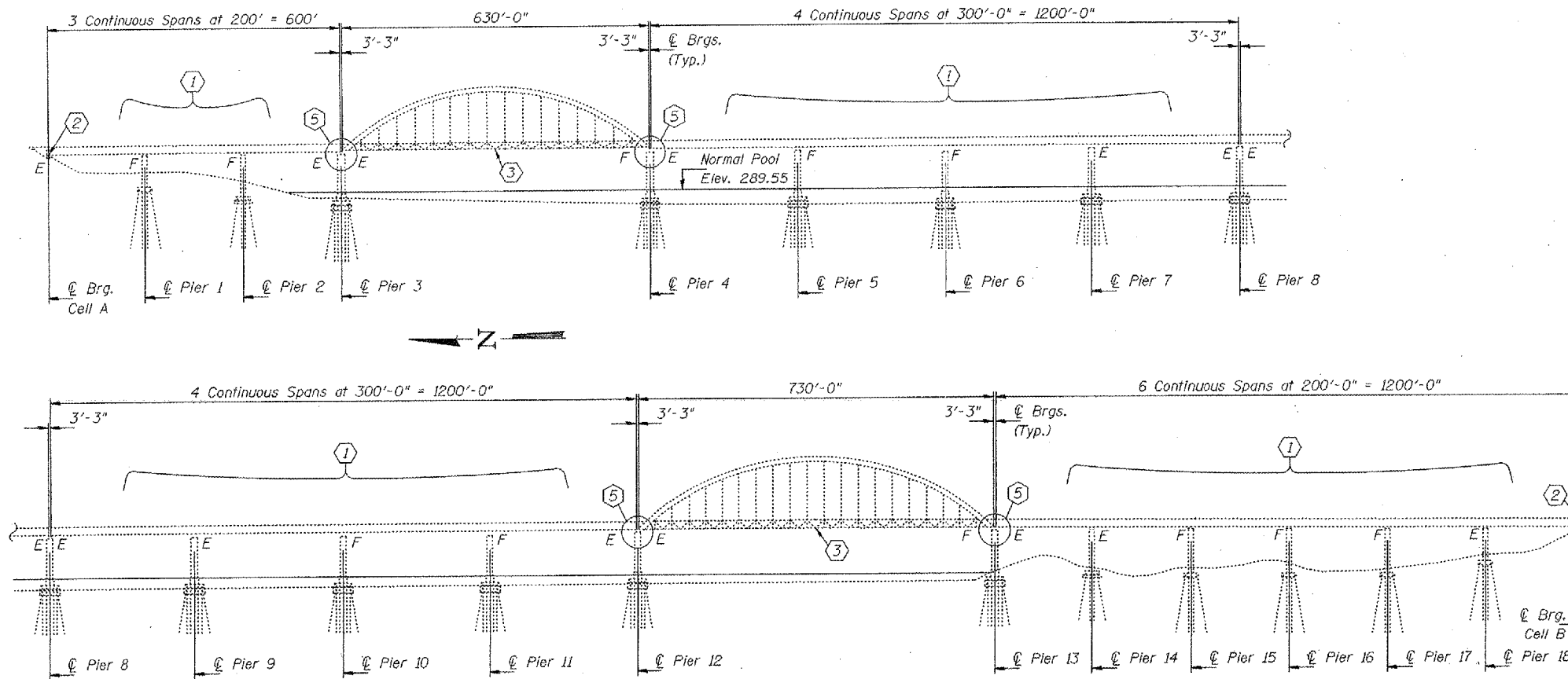

ELEVATION

- ① Core drill longitudinal stiffeners. See repair detail "P" on sheet 18 of 22. See framing plans on sheets 2 thru 9 of 22 for exact locations and quantity.
- ② Remove and replace existing Rocker Bearings with Pot Bearings and Concrete Pedestals. See repair detail "Q" on Sheets 19 and 20 of 22.
- ③ Cable retrofit in bottom chord of arched spans. See repair detail "R" on Sheet 21 of 22.
- ④A Thru
- ④M
- ⑤ Remove and Replace broken bolts at finger plates. See Repair Detail "S" on this sheet.

* Missing or broken 7/8" φ bolts at these locations shall be replaced. Contractor must verify shim pack thickness in order to determine appropriate bolt length at each location. (Estimated number of bolts required = 35). Cost included with Structural Steel Repair.

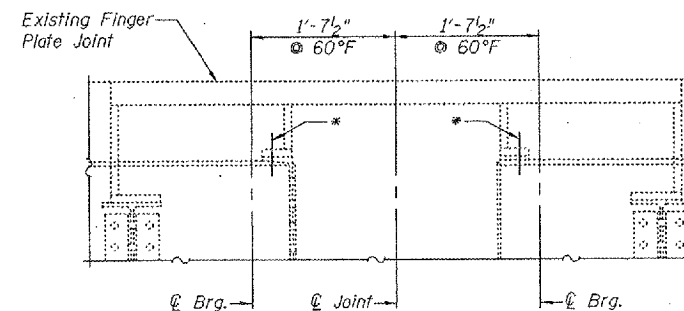

REPAIR DETAIL "S"

GENERAL NOTES

- All new structural steel shall conform to AASHTO Classification M-270 Gr. 36. Unless otherwise noted.
- All new fasteners shall be high strength bolts. Holes shall be 1/16" φ for 3/4" φ high strength bolts (except as noted on the plans).
- Plan dimensions and details relative to existing structure have been taken from existing plans and are subject to nominal construction variations. It shall be the Contractor's responsibility to verify such dimensions and details in the field and make necessary approved adjustments prior to construction or ordering of materials. Such variations shall not be cause for additional compensation for a change in the scope of the work, however, the Contractor will be paid for the quantity actually furnished at the unit price bid for the work.
- The existing structural steel coating contains lead. The Contractor should take appropriate precautions to deal with the presence of lead on this project.
- Existing Structural steel shall only be cleaned and painted as required by the Special Provision "Cleaning and Painting Adjacent Areas of Existing Steel Structures".
- All stringer and repairs shall be considered to be primary connections.
- The Contractor shall ensure that no infringement of the navigational underclearance or channel occurs while doing the work. Any infringement shall be approved by the Coast Guard. The Contractor shall contact Mr. Roger Wlebusch, Eighth Coast Guard District, 1222 Spruce Street, St. Louis, Mo. 63103, (314)-539-3900 for requirements needed to obtain the necessary permits.
- Contractor must ensure that no debris remains inside the bottom chords after the Post-Tension Cable Retrofit work is completed.
- Direction indicator barricades shall be required on all lane closure tapers.
- The inorganic zinc rich primer / acrylic / acrylic paint system shall be used for shop and field painting of new structural steel except where otherwise noted. The color of the final finish coat shall be Gray, Munsell No. 5B 7/1. See special provisions for Cleaning and Painting New Metal Structures. Cost included with Structural Steel Repair.

TOTAL BILL OF MATERIAL

ITEM	UNIT	QUANTITY
Structural Steel Repair	Pound	11070
Stiffener Intersection Modification	Each	1055
Post-Tension Cable Retrofit	Each	912
Concrete Structures	Cu. Yd.	3.4
Reinforcement Bars, Epoxy Coated	Pound	450
Removal of Existing Bearings	Each	4
Jacking and Cribbing	Each	4
Floating Bearings, Guided Exp. 700 K.	Each	4

DESIGNED *Paul J. Moran*
CHECKED *VICTOR H. VELLEZ*
DRAWN *[Signature]*
CHECKED *PSSJ VHV*

March 27, 2003
EXAMINED *John A. Morris*
PASSED
ENGINEER OF BRIDGES AND STRUCTURES

REVISED PLAN SHEETS

ELEVATION
F.A.I. 24 OVER OHIO RIVER
MASSAC COUNTY
S.N. 064-0035

STATE OF ILLINOIS
DEPARTMENT OF TRANSPORTATION

ROUTE NO.	SECTION
24	*
* 64-3B	

CONTRACT: 98990
ROUTE: INTERSTATE 24
SECTION: (64-3B) I-6
COUNTY: MASSAC, IL; McCRACKEN, KY
SHEET 82 OF 99
FOR INFORMATION ONLY

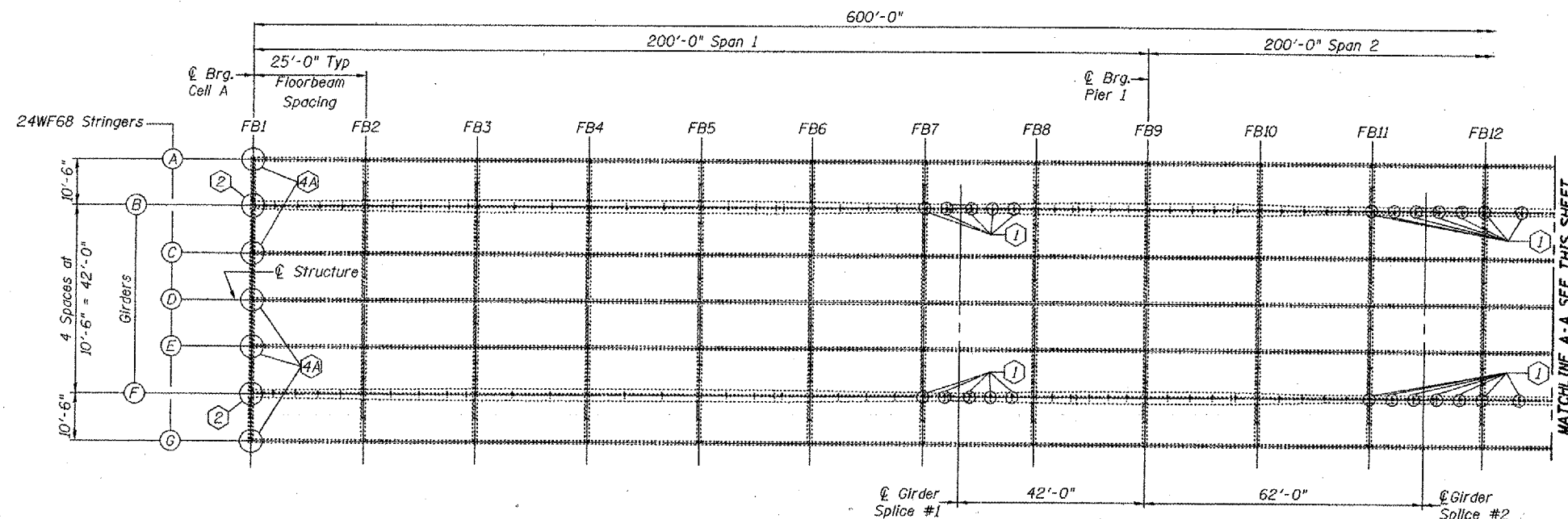

**PARTIAL FRAMING PLAN
SPANS 1 AND 2**

Notes:

FB*** = Floor Beam Number

- ① Core drill longitudinal stiffeners. See repair detail "P" on sheet 18 of 22.
 - ② Remove and replace existing Rocker Bearings with Pot Bearings and Concrete Pedestals. See repair detail "Q" on sheets 19 and 20 of 22.
 - ④A Stringer end repair. See repair detail "A" on sheet 11 of 22.
 - ④B Stringer end repair. See repair detail "B" on sheet 11 of 22.
- * Before installing angles, grind stringer end (See Detail on Sheet 10 of 22).

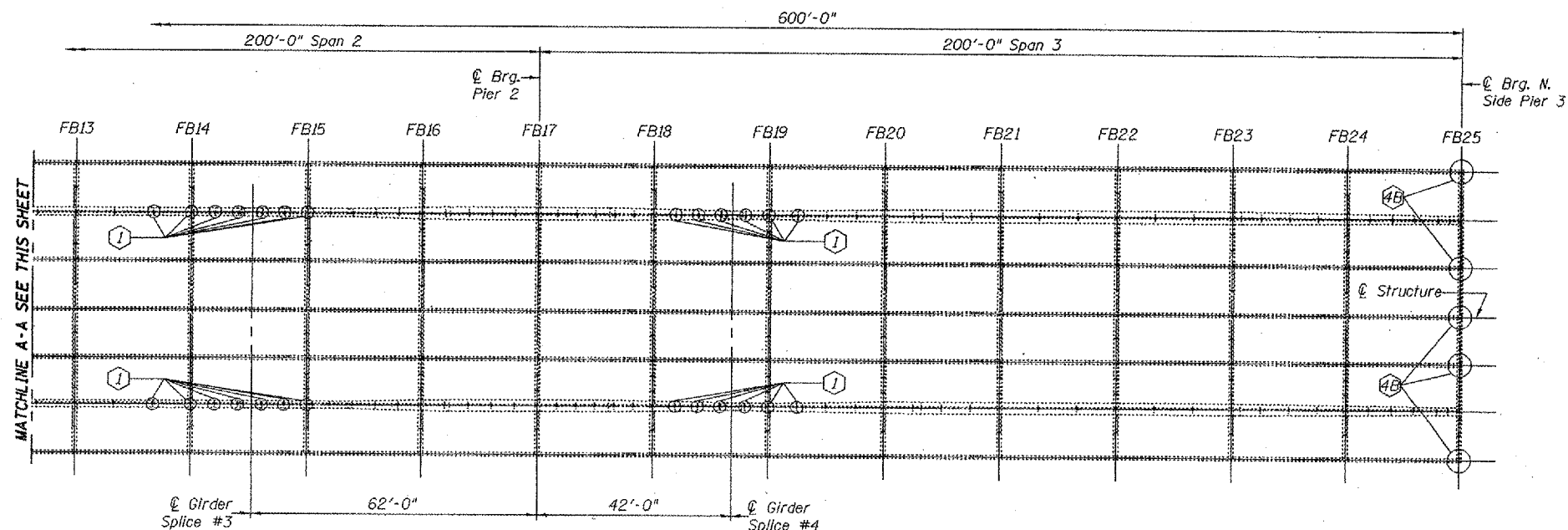

**PARTIAL FRAMING PLAN
SPANS 2 AND 3**

DESIGNED	P.S.J.
CHECKED	V.H.V.
DRAWN	Drew Christopher
CHECKED	P.S.J. V.H.V.

December 6, 2002
EXAMINED *John A. Morris*
ENGINEER OF STRUCTURAL SERVICES
PASSED
ENGINEER OF BRIDGES AND STRUCTURES

**FRAMING PLANS
F.A.I. 24 OVER OHIO RIVER
MASSAC COUNTY
S.N. 064-0035**

STATE OF ILLINOIS
DEPARTMENT OF TRANSPORTATION

CONTRACT: 98990
ROUTE: INTERSTATE 24
SECTION: (64-3B) I-6
COUNTY: MASSAC, IL; McCRACKEN, KY
SHEET 83 OF 99
FOR INFORMATION ONLY

ROUTE NO.	SECTION
F.A.I. 24	*
FED. ROAD DIST. NO. 7	
*64-3B	

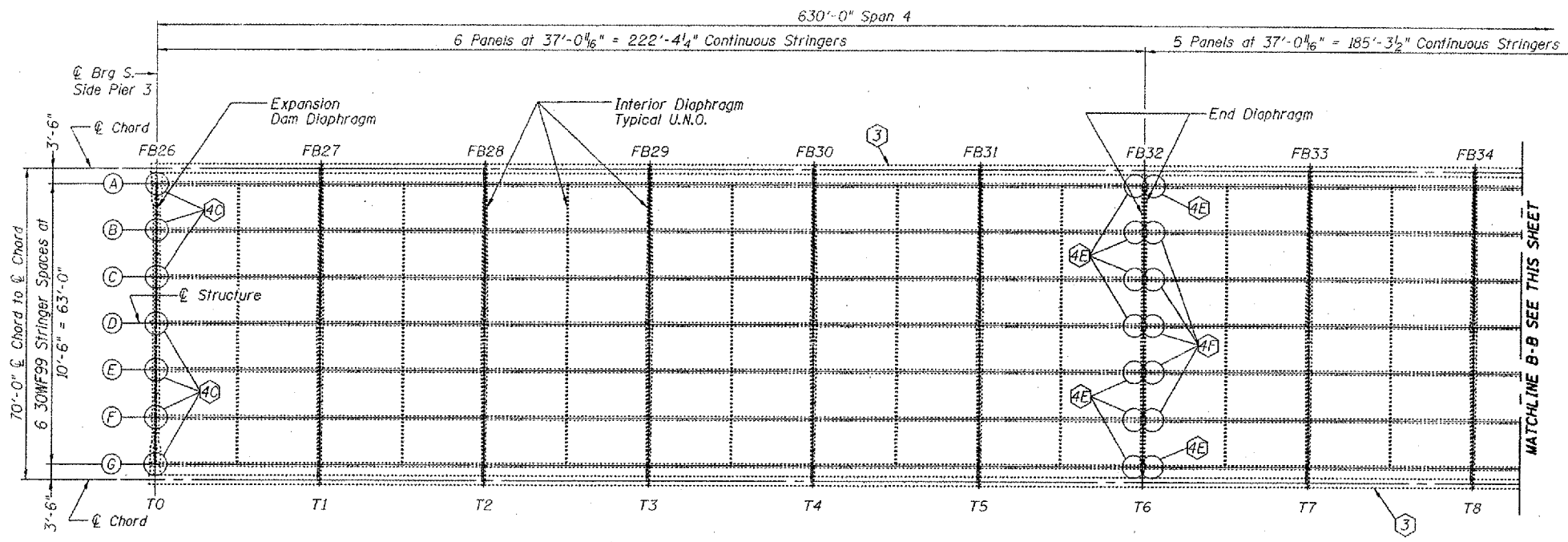

**PARTIAL FRAMING PLAN
SPAN 4**

Notes:
FB*** = Floor Beam Number
T** = Tie Down Point Number

- ③ Cable retrofit in bottom chord of arched spans. See repair detail "R" on sheet 21 of 22.
- *4C Stringer end repair. See repair detail "C" on sheet 12 of 22.
- *4D Stringer end repair. See repair detail "D" on sheet 12 of 22.
- *4E Stringer end repair. See repair detail "E" on sheet 13 of 22.
- *4F Stringer end repair. See repair detail "F" on sheet 13 of 22.

* Before installing angles, grind stringer end (See Detail on Sheet 10 of 22).

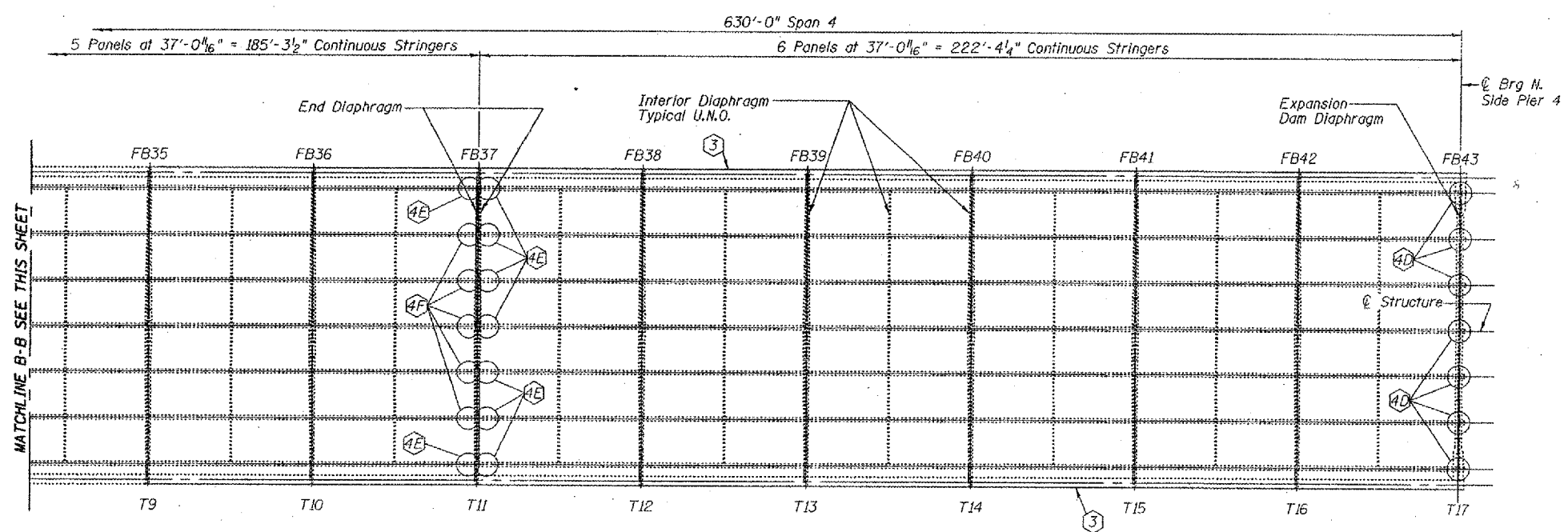
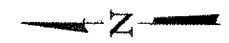

**PARTIAL FRAMING PLAN
SPAN 4**

DESIGNED	P.S.J.
CHECKED	V.H.V.
DRAWN	Drew Christopher
CHECKED	P.S.J., V.H.V.

December 6, 2002
EXAMINED *John A. Morris*
ENGINEER OF STRUCTURAL SERVICES
PASSED
ENGINEER OF BRIDGES AND STRUCTURES

FRAMING PLANS
F.A.I. 24 OVER OHIO RIVER
MASSAC COUNTY
S.N. 064-0035

STATE OF ILLINOIS
DEPARTMENT OF TRANSPORTATION

CONTRACT: 98990
ROUTE: INTERSTATE 24
SECTION: (64-3B) I-6
COUNTY: MASSAC, IL; McCracken, KY
SHEET 84 OF 99
FOR INFORMATION ONLY

ROUTE NO. 24
SECTION *
F.A.I. 24
FED. ROAD DIST. NO. 7
*64-

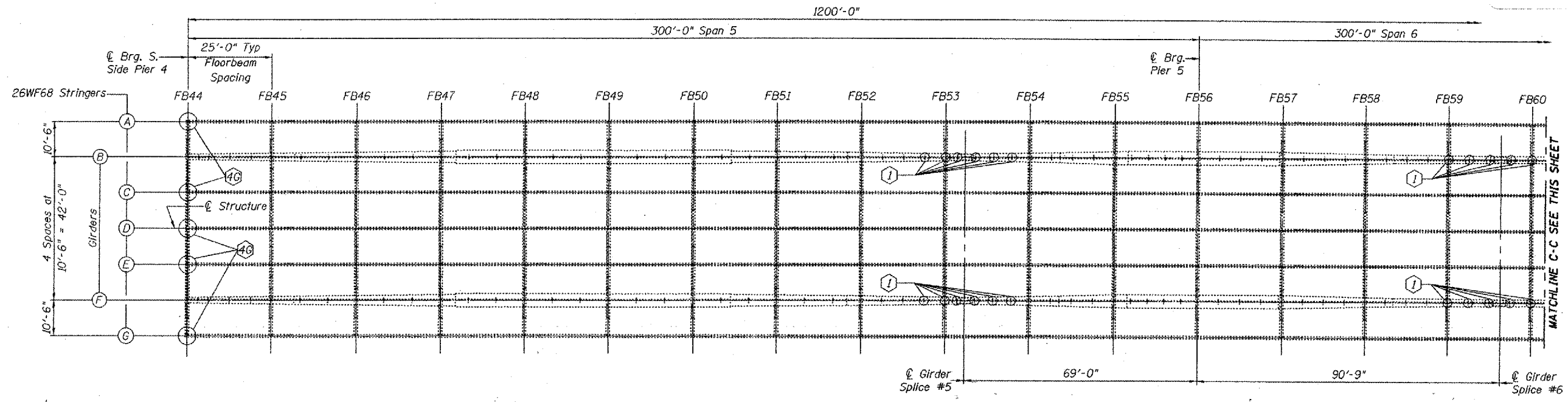

**PARTIAL FRAMING PLAN
SPANS 5 AND 6**

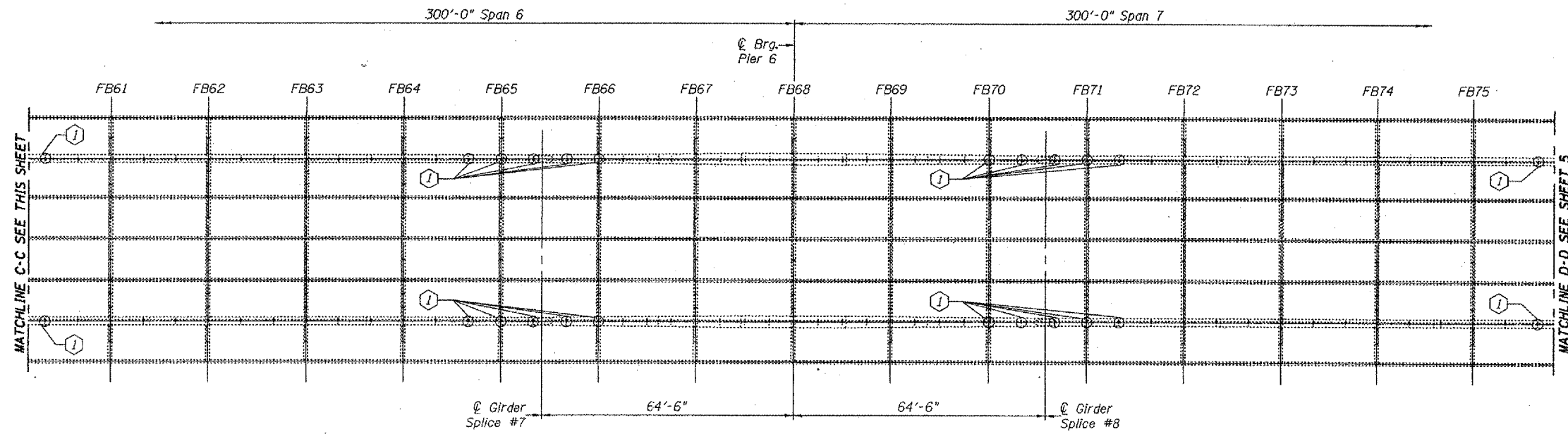
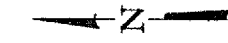

**PARTIAL FRAMING PLAN
SPANS 6 AND 7**

Notes:

FB*** = Floor Beam Number

① Core drill longitudinal stiffeners. See repair detail "P" on sheet 18 of 22.

*④G Stringer end repair. See repair detail "G" on sheet 14 of 22.

* Before installing angles, grind stringer end (See Detail on Sheet 10 of 22).

DESIGNED	P.S.J.
CHECKED	V.H.V.
DRAWN	Drew Christopher
CHECKED	P.S.J. V.H.V.

December 6, 2002
EXAMINED *John A. Morris*
PASSED
ENGINEER OF BRIDGES AND STRUCTURES

**FRAMING PLANS
F.A.I. 24 OVER OHIO RIVER
MASSAC COUNTY
S.N. 064-0035**

STATE OF ILLINOIS
DEPARTMENT OF TRANSPORTATION

CONTRACT: 98990
ROUTE: INTERSTATE 24
SECTION: (64-3B) I-6
COUNTY: MASSAC, IL; McCracken, KY
SHEET 85 OF 95
FOR INFORMATION ONLY

ROUTE NO.	SHEET
F.A.I. 24	*
FED. ROAD DIST. NO. 1	

*64-3B-I-5

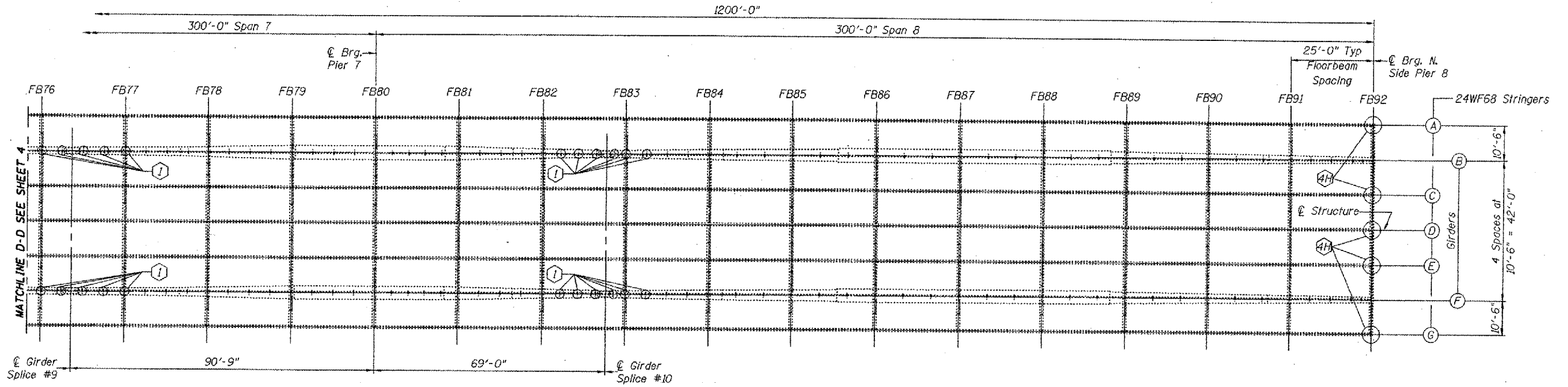

**PARTIAL FRAMING PLAN
SPANS 7 AND 8**

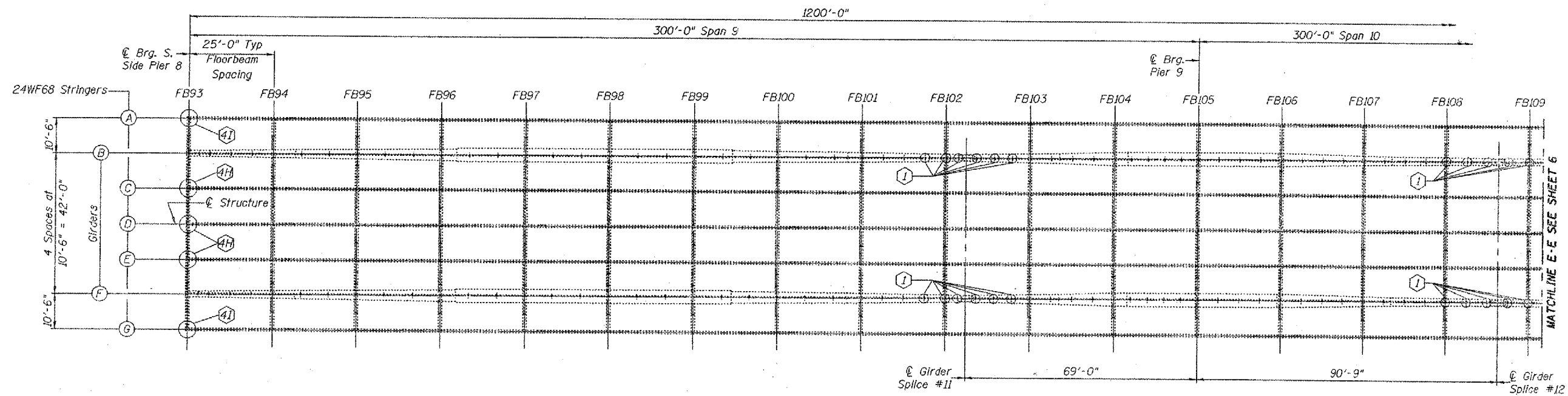
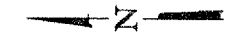

**PARTIAL FRAMING PLAN
SPANS 9 AND 10**

Notes:

FB*** = Floor Beam Number

- Ⓜ Core drill longitudinal stiffeners. See repair detail "P" on sheet 18 of 22.
- * 4H Stringer end repair. See repair detail "H" on sheet 14 of 22.
- * 4I Stringer end repair. See repair detail "I" on sheet 15 of 22.

* Before installing angles, grind stringer end (See Detail on Sheet 10 of 22).

DESIGNED	P.S.J.
CHECKED	V.H.V.
DRAWN	Drew Christopher
CHECKED	P.S.J. V.H.V.

December 6, 2002
EXAMINED *John A. Morris*
ENGINEER OF STRUCTURAL SERVICES
PASSED
ENGINEER OF BRIDGES AND STRUCTURES

**FRAMING PLANS
F.A.I. 24 OVER OHIO RIVER
MASSAC COUNTY
S.N. 064-0035**

STATE OF ILLINOIS
DEPARTMENT OF TRANSPORTATION

ROUTE NO.	SECT.
FAI 24	*
FED. ROAD DIST. NO. 7	

CONTRACT: 98990
ROUTE: INTERSTATE 24
SECTION: (64-3B) I-6
COUNTY: MASSAC, IL; McCRACKEN, KY
SHEET 86 OF 99
*64
FOR INFORMATION ONLY

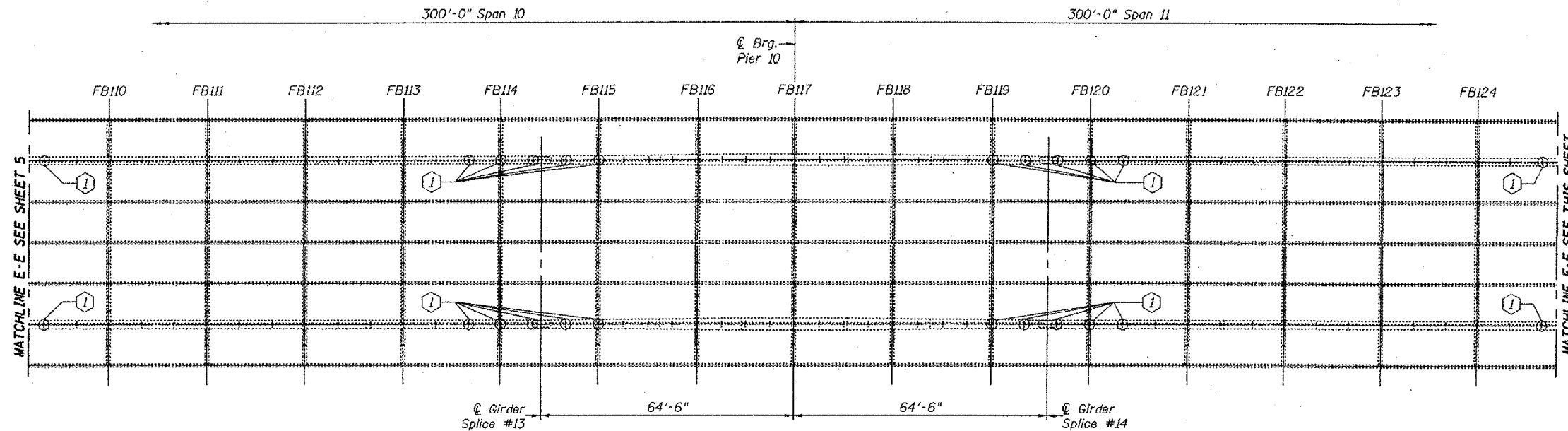

**PARTIAL FRAMING PLAN
SPANS 10 AND 11**

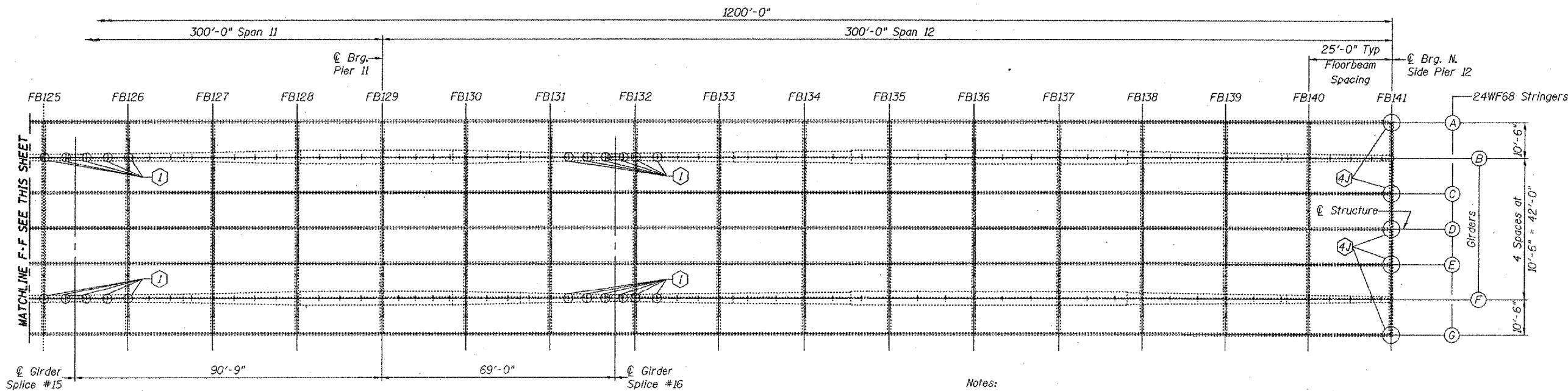
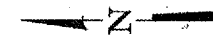

**PARTIAL FRAMING PLAN
SPANS 11 AND 12**

Notes:

FB*** = Floor Beam Number

(I) Core drill longitudinal stiffeners. See repair detail "P" on sheet 18 of 22.

* (AJ) Stringer end repair. See repair detail "J" on sheet 15 of 22.

* Before installing angles, grind stringer end (See Detail on Sheet 10 of 22).

DESIGNED	P.S.J.
CHECKED	V.H.V.
DRAWN	Drew Christopher
CHECKED	P.S.J. V.H.V.

December 6, 2002
EXAMINED *John A. Morris*
ENGINEER OF STRUCTURAL SERVICES
PASSED
ENGINEER OF BRIDGES AND STRUCTURES

**FRAMING PLANS
F.A.I. 24 OVER OHIO RIVER
MASSAC COUNTY
S.N. 064-0035**

STATE OF ILLINOIS
DEPARTMENT OF TRANSPORTATION

ROUTE NO. 24
F.A.I. 24
FED. ROAD DIST. NO.

CONTRACT: 98990
ROUTE: INTERSTATE 24
SECTION: (64-3B) I-6
COUNTY: MASSAC, IL; McCRACKEN, KY
SHEET 87 OF 99
FOR INFORMATION ONLY

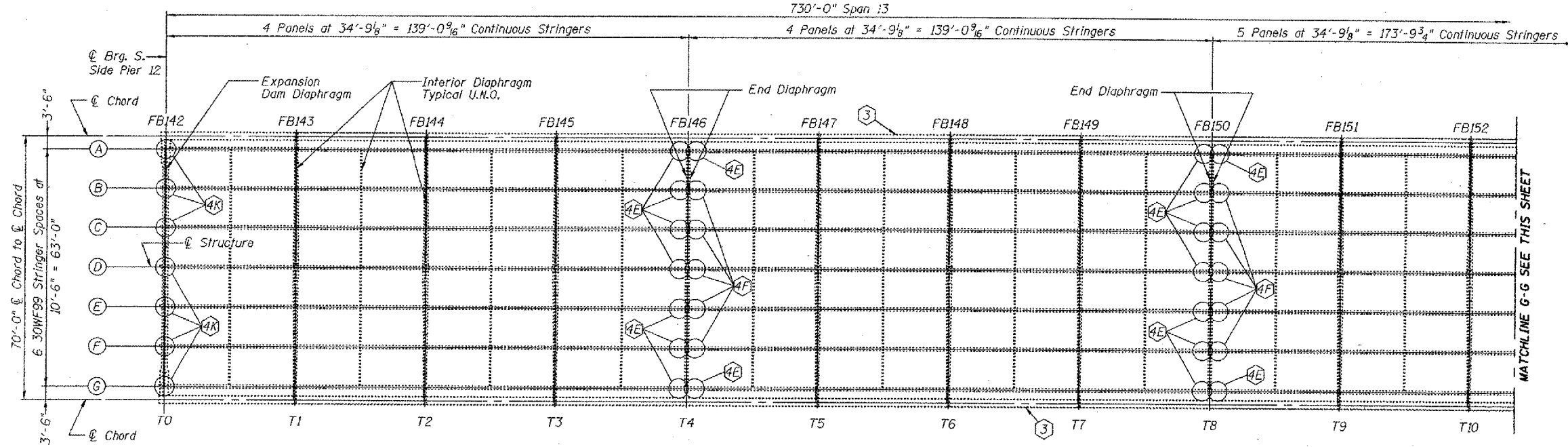

PARTIAL FRAMING PLAN
SPAN 13

Notes:

FB*** = Floor Beam Number
T** = Tie Down Point Number

- ③ Strand repair in bottom chord of arched spans. See repair detail "R" on Sheet 21 of 22.
- * 4E Stringer end repair. See repair detail "E" on sheet 13 of 22.
- * 4F Stringer end repair. See repair detail "F" on sheet 13 of 22.
- * 4K Stringer end repair. See repair detail "K" on sheet 16 of 22.
- * 4L Stringer end repair. See repair detail "L" on sheet 16 of 22.

* Before installing angles, grind stringer end (See Detail on Sheet 10 of 22).

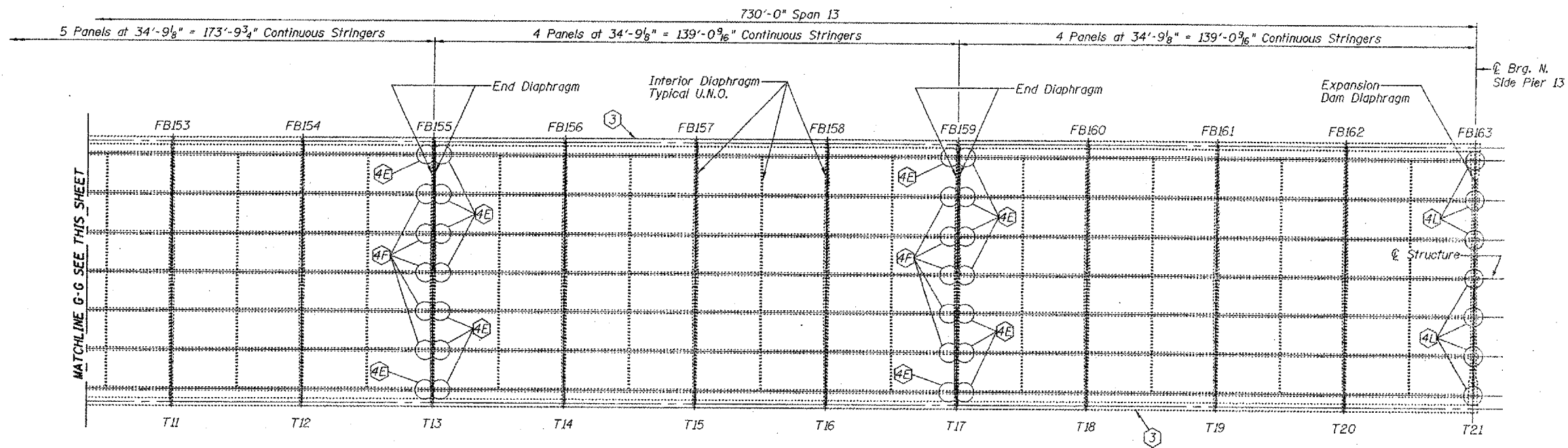
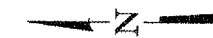

PARTIAL FRAMING PLAN
SPAN 13

DESIGNED P.S.J.	December 6, 2002
CHECKED V.H.V.	EXAMINED <i>John A. Morris</i> ENGINEER OF STRUCTURAL SERVICES
DRAWN Drew Christopher	PASSED
CHECKED P.S.J. V.H.V.	ENGINEER OF BRIDGES AND STRUCTURES

FRAMING PLANS
F.A.I. 24 OVER OHIO RIVER
MASSAC COUNTY
S.N. 064-0035

STATE OF ILLINOIS
DEPARTMENT OF TRANSPORTATION

ROUTE NO.	FAI 24
FED. ROAD DIST. NO.	24

CONTRACT: 98990
ROUTE: INTERSTATE 24
SECTION: (64-3B) I-6
COUNTY: MASSAC, IL; McCRACKEN, KY
SHEET 88 OF 99
FOR INFORMATION ONLY

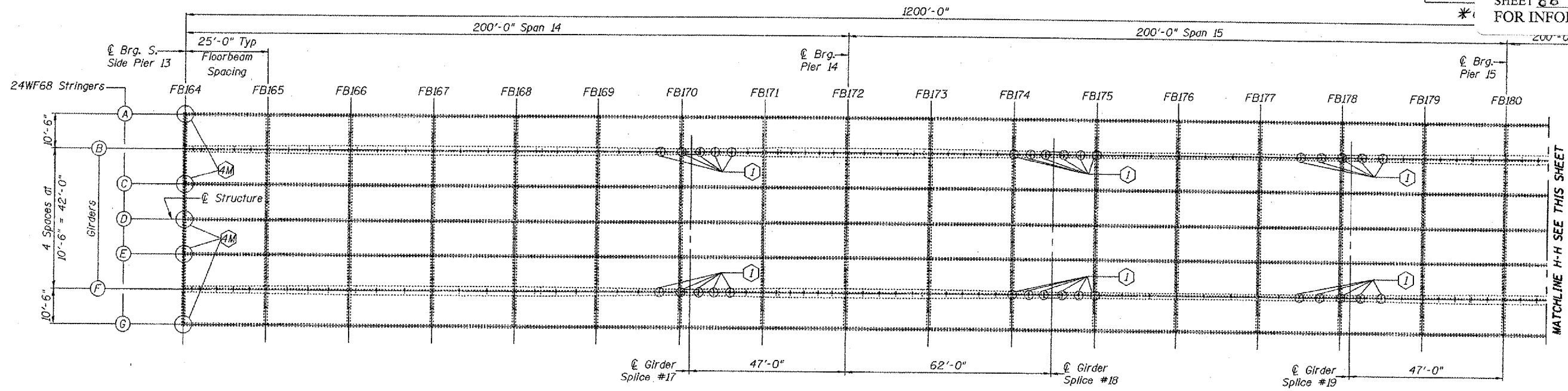

**PARTIAL FRAMING PLAN
SPANS 14, 15 AND 16**

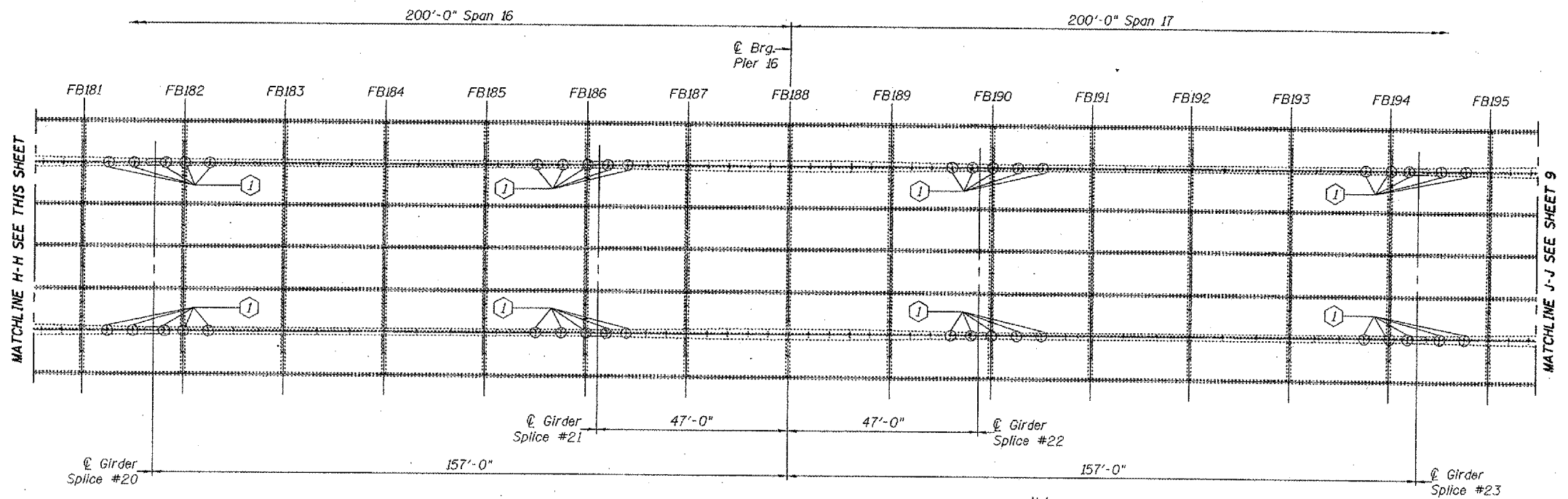
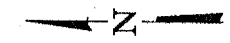

**PARTIAL FRAMING PLAN
SPANS 16 AND 17**

DESIGNED	P.S.J.
CHECKED	V.H.V.
DRAWN	Drew Christopher
CHECKED	P.S.J. V.H.V.

December 5, 2002
EXAMINED *John A. Morris*
ENGINEER OF STRUCTURAL SERVICES
PASSED

* Before installing angles, grind stringer end (See Detail on Sheet 10 of 22).

- Notes:
- FB*** = Floor Beam Number
 - (I) Core drill longitudinal stiffeners. See repair detail "P" on sheet 18 of 22.
 - (M) Stringer end repair. See repair detail "M" on sheet 17 of 22.

**FRAMING PLANS
F.A.I. 24 OVER OHIO RIVER
MASSAC COUNTY
S.N. 064-0035**

STATE OF ILLINOIS
DEPARTMENT OF TRANSPORTATION

ROUTE NO.	SECTION
F.A.I. 24	*
FED. ROAD DIST. NO. 7	

CONTRACT: 98990
ROUTE: INTERSTATE 24
SECTION: (64-3B) 1-6
COUNTY: MASSAC. IL; McCRACKEN, KY
SHEET 89 OF 99
FOR INFORMATION ONLY

*64

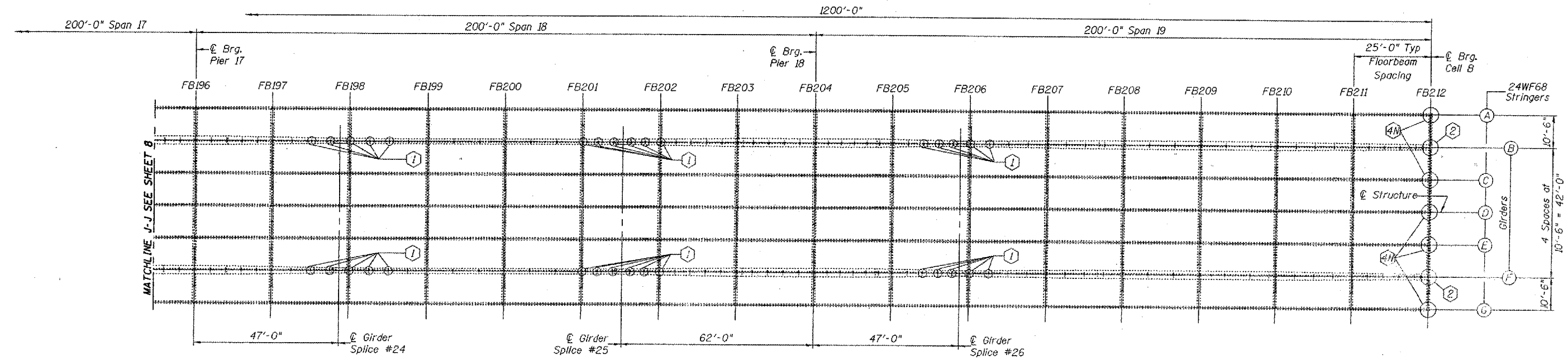
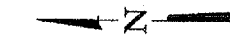

**PARTIAL FRAMING PLAN
SPANS 17, 18 AND 19**

Notes:

FB*** = Floor Beam Number

- ① Core drill longitudinal stiffeners. See repair detail "P" on sheet 18 of 22.
- ② Remove and replace existing Rocker Bearings with Pot Bearings and Concrete Pedestals. See repair detail "Q" on sheets 19 and 20 of 22.
- * 4M Stringer end repair. See repair detail "N" on sheet 17 of 22.

* Before installing angles, grind stringer end (See Detail on Sheet 10 of 22).

DESIGNED	P.S.J.
CHECKED	V.H.V.
DRAWN	Drew Christopher
CHECKED	P.S.J., V.H.V.

December 6, 2002
EXAMINED *John A. Morris*
ENGINEER OF STRUCTURAL SERVICES
PASSED
ENGINEER OF BRIDGES AND STRUCTURES

**FRAMING PLAN
F.A.I. 24 OVER OHIO RIVER
MASSAC COUNTY
S.N. 064-0035**



CONTRACT: 98990
 ROUTE: INTERSTATE 24
 SECTION: (64-3B) I-6
 COUNTY: MASSAC, IL; McCracken, KY
 SHEET **90** OF **99**
FOR INFORMATION ONLY

Location of Stringer End Repairs on Bridge	Stringer Identification	Location of Angle on Stringer	Angle and Plate ID Numbers
Repair Detail "A" on Page 11 Cell A Span 1 Looking South	East Fascia Stringer A	East Side	A1
		West Side	A2
	Stringer C	East Side	A1
		West Side	A2
	Stringer D	East Side	A1
		West Side	A2
Stringer E	East Side	A1	
	West Side	A2	
West Fascia Stringer G	East Side	A1	
	West Side	A2	
Repair Detail "B" on Page 11 North Side of Pier 3, Span 3 Looking North	East Fascia Stringer A	East Side	B2 & P1
		West Side	B1
	Stringer C	East Side	B4
		West Side	B3
	Stringer D	East Side	B4
		West Side	B3
Stringer E	East Side	B4	
	West Side	B3	
West Fascia Stringer G	East Side	B6	
	West Side	B5 & P1	
Repair Detail "C" on Page 12 South Side of Pier 3, Span 4 Looking South	East Fascia Stringer A	East Side	C1 & P2
		West Side	C2
	Stringer B	East Side	C3
		West Side	C4
	Stringer C	East Side	C3
		West Side	C4
Stringer D	East Side	C5	
	West Side	C6	
Stringer E	East Side	C3	
	West Side	C4	
West Fascia Stringer G	East Side	C7	
	West Side	C8 & P2	
Repair Detail "E" on Page 13 North Side of T6 Span 4 Looking North	East Fascia Stringer A	East Side	E3
		West Side	E1 & E2
	Stringer B	East Side	E5 & E6
		West Side	E1 & E2
	Stringer C	East Side	E5 & E6
		West Side	E1 & E2
Stringer D	East Side	E5 & E6	
	West Side	E1 & E2	
Stringer E	East Side	E5 & E6	
	West Side	E1 & E2	
Stringer F	East Side	E5 & E6	
	West Side	E1 & E2	
West Fascia Stringer G	East Side	E5 & E6	
	West Side	E4	
Repair Details "E" and "F" on Page 13 South Side of T6 Span 4 Looking South	East Fascia Stringer A	East Side	E4
		West Side	E5 & E6
	Stringer B	East Side	E1 & F1
		West Side	F2 & E6
	Stringer C	East Side	E1 & F1
		West Side	F2 & E6
Stringer D	East Side	E1 & F1	
	West Side	F2 & E6	
Stringer E	East Side	E1 & F1	
	West Side	F2 & E6	
Stringer F	East Side	E1 & F1	
	West Side	F2 & E6	
West Fascia Stringer G	East Side	E1 & E2	
	West Side	E3	

Location of Stringer End Repairs on Bridge	Stringer Identification	Location of Angle on Stringer	Angle and Plate ID Numbers
Repair Details "E" and "F" on Page 13 North Side of T11 Span 4 Looking North	East Fascia Stringer A	East Side	E3
		West Side	E1 & E2
	Stringer B	East Side	F2 & E6
		West Side	E1 & F1
	Stringer C	East Side	F2 & E6
		West Side	E1 & F1
Stringer D	East Side	F2 & E6	
	West Side	E1 & F1	
Stringer E	East Side	F2 & E6	
	West Side	E1 & F1	
Stringer F	East Side	F2 & E6	
	West Side	E1 & F1	
West Fascia Stringer G	East Side	E5 & E6	
	West Side	E4	
Repair Detail "E" on Page 13 South Side of T11 Span 4 Looking South	East Fascia Stringer A	East Side	E4
		West Side	E5 & E6
	Stringer B	East Side	E1 & E2
		West Side	E5 & E6
	Stringer C	East Side	E1 & E2
		West Side	E5 & E6
Stringer D	East Side	E1 & E2	
	West Side	E5 & E6	
Stringer E	East Side	E1 & E2	
	West Side	E5 & E6	
Stringer F	East Side	E1 & E2	
	West Side	E5 & E6	
West Fascia Stringer G	East Side	E1 & E2	
	West Side	E3	
Repair Detail "D" on Page 12 North Side of Pier 4, Span 4 Looking North	East Fascia Stringer A	East Side	D2 & P3
		West Side	D1
	Stringer B	East Side	D4
		West Side	D3
	Stringer C	East Side	D4
		West Side	D3
Stringer D	East Side	D6	
	West Side	D5	
Stringer E	East Side	D4	
	West Side	D3	
Stringer F	East Side	D4	
	West Side	D3	
West Fascia Stringer G	East Side	D8	
	West Side	D7 & P3	
Repair Detail "C" on Page 14 South Side of Pier 4, Span 5 Looking South	East Fascia Stringer A	East Side	G1 & P4
		West Side	G2
	Stringer C	East Side	G3
		West Side	G2
	Stringer D	East Side	G3
		West Side	G2
Stringer E	East Side	G3	
	West Side	G2	
Stringer F	East Side	G3	
	West Side	G2	
West Fascia Stringer G	East Side	G4 & P4	
	West Side	G3	
Repair Detail "H" on Page 14 North Side of Pier 8, Span 8 Looking North	East Fascia Stringer A	East Side	H2 & P5
		West Side	H1
	Stringer C	East Side	H4
		West Side	H3
	Stringer D	East Side	H4
		West Side	H3
Stringer E	East Side	H4	
	West Side	H3	
Stringer F	East Side	H4	
	West Side	H3	
West Fascia Stringer G	East Side	H6	
	West Side	H5 & P5	
Repair Details "H" and "I" on Pages 14 & 15 South Side of Pier 8, Span 9 Looking South	East Fascia Stringer A	East Side	I1 & P6
		West Side	H6
	Stringer C	East Side	H3
		West Side	H4
	Stringer D	East Side	H3
		West Side	H4
Stringer E	East Side	H3	
	West Side	H4	
Stringer F	East Side	H3	
	West Side	H4	
West Fascia Stringer G	East Side	H1	
	West Side	I2 & P6	

Location of Stringer End Repairs on Bridge	Stringer Identification	Location of Angle on Stringer	Angle and Plate ID Numbers
Repair Detail "J" on Page 15 North Side of Pier 12, Span 12 Looking North	East Fascia Stringer A	East Side	J2 & P7
		West Side	J1
	Stringer C	East Side	J4
		West Side	J3
	Stringer D	East Side	J4
		West Side	J3
Stringer E	East Side	J4	
	West Side	J3	
West Fascia Stringer G	East Side	J6	
	West Side	J5 & P7	
Repair Detail "K" on Page 16 South Side of Pier 12, Span 13 Looking South	East Fascia Stringer A	East Side	K1
		West Side	K2
	Stringer B	East Side	K3
		West Side	K4
	Stringer C	East Side	K5
		West Side	K6
Stringer D	East Side	K5	
	West Side	K6	
Stringer E	East Side	K5	
	West Side	K6	
Stringer F	East Side	K3	
	West Side	K4	
West Fascia Stringer G	East Side	K1	
	West Side	K2	
Repair Detail "E" on Page 13 North Side of T4 Span 13 Looking North	East Fascia Stringer A	East Side	E3
		West Side	E1 & E2
	Stringer B	East Side	E5 & E6
		West Side	E1 & E2
	Stringer C	East Side	E5 & E6
		West Side	E1 & E2
Stringer D	East Side	E5 & E6	
	West Side	E1 & E2	
Stringer E	East Side	E5 & E6	
	West Side	E1 & E2	
Stringer F	East Side	E5 & E6	
	West Side	E1 & E2	
West Fascia Stringer G	East Side	E5 & E6	
	West Side	E4	
Repair Details "E" and "F" on Page 13 South Side of T4 Span 13 Looking South	East Fascia Stringer A	East Side	E4
		West Side	E5 & E6
	Stringer B	East Side	E1 & F1
		West Side	F2 & E6
	Stringer C	East Side	E1 & F1
		West Side	F2 & E6
Stringer D	East Side	E1 & F1	
	West Side	F2 & E6	
Stringer E	East Side	E1 & F1	
	West Side	F2 & E6	
Stringer F	East Side	E1 & F1	
	West Side	F2 & E6	
West Fascia Stringer G	East Side	E1 & E2	
	West Side	E3	
Repair Detail "E" on Page 13 North Side of T8 Span 13 Looking North	East Fascia Stringer A	East Side	E3
		West Side	E1 & E2
	Stringer B	East Side	E5 & E6
		West Side	E1 & E2
	Stringer C	East Side	E5 & E6
		West Side	E1 & E2
Stringer D	East Side	E5 & E6	
	West Side	E1 & E2	
Stringer E	East Side	E5 & E6	
	West Side	E1 & E2	
Stringer F	East Side	E5 & E6	
	West Side	E1 & E2	
West Fascia Stringer G	East Side	E1 & E2	
	West Side	E4	

Location of Stringer End Repairs on Bridge	Stringer Identification	Location of Angle on Stringer	Angle and Plate ID Numbers
Repair Details "E" and "F" on Page 13 South Side of T8 Span 13 Looking South	East Fascia Stringer A	East Side	E4
		West Side	E5 & E6
	Stringer B	East Side	E1 & F1
		West Side	F2 & E6
	Stringer C	East Side	E1 & F1
		West Side	F2 & E6
Stringer D	East Side	E1 & F1	
	West Side	F2 & E6	
Stringer E	East Side	E1 & F1	
	West Side	F2 & E6	
Stringer F	East Side	E1 & F1	
	West Side	F2 & E6	
West Fascia Stringer G	East Side	E1 & E2	
	West Side	E3	
Repair Details "E" and "F" on Page 13 North Side of T13 Span 13 Looking North	East Fascia Stringer A	East Side	E3
		West Side	E1 & E2
	Stringer B	East Side	F2 & E6
		West Side	E1 & F1
	Stringer C	East Side	F2 & E6
		West Side	E1 & F1
Stringer D	East Side	F2 & E6	
	West Side	E1 & F1	
Stringer E	East Side	F2 & E6	
	West Side	E1 & F1	
Stringer F	East Side	F2 & E6	
	West Side	E1 & F1	
West Fascia Stringer G	East Side	E5 & E6	
	West Side	E4	
Repair Detail "E" on Page 13 South Side of T13 Span 13 Looking South	East Fascia Stringer A	East Side	E4
		West Side	E5 & E6
	Stringer B	East Side	E1 & E2
		West Side	E5 & E6
	Stringer C	East Side	E1 & E2
		West Side	E5 & E6
Stringer D	East Side	E1 & E2	
	West Side	E5 & E6	
Stringer E	East Side	E1 & E2	
	West Side	E5 & E6	
Stringer F	East Side	E1 & E2	
	West Side	E5 & E6	
West Fascia Stringer G	East Side	E1 & E2	
	West Side	E4	
Repair Details "E" and "F" on Page 13 North Side of T17 Span 13 Looking North	East Fascia Stringer A	East Side	E3
		West Side	E1 & E2
	Stringer B	East Side	F2 & E6
		West Side	E1 & F1
	Stringer C	East Side	F2 & E6
		West Side	E1 & F1
Stringer D	East Side	F2 & E6	
	West Side	E1 & F1	
Stringer E	East Side	F2 & E6	
	West Side	E1 & F1	
Stringer F	East Side	F2 & E6	
	West Side	E1 & F1	
West Fascia Stringer G	East Side	E1 & E2	
	West Side	E3	
Repair Detail "E" on Page 13 South Side of T17 Span 13 Looking South	East Fascia Stringer A	East Side	E3
		West Side	E1 & E2
	Stringer B	East Side	E5 & E6
		West Side	E1 & E2
	Stringer C	East Side	E5 & E6
		West Side	E1 & E2
Stringer D	East Side	E5 & E6	
	West Side	E1 & E2	
Stringer E	East Side	E5 & E6	
	West Side	E1 & E2	
Stringer F	East Side	E5 & E6	
	West Side	E1 & E2	
West Fascia Stringer G	East Side	E1 & E2	
	West Side	E4	

Location of Stringer End Repairs on Bridge	Stringer Identification	Location of Angle on Stringer	Angle and Plate ID Numbers
Repair Detail "L" on Page 16 North Side of Pier 13, Span 13 Looking North	East Fascia Stringer A	East Side	L2 & P8
		West Side	L1
	Stringer B	East Side	L4
		West Side	L3
	Stringer C	East Side	L6
		West Side	L5
Stringer D	East Side	L6	
	West Side	L5	
Stringer E	East Side	L6	
	West Side	L5	
Stringer F	East Side	L4	
	West Side	L3	
West Fascia Stringer G	East Side	L8	
	West Side	L7 & P8	
Repair Detail "M" on Page 17 South Side of Pier 13, Span 14 Looking South	East Fascia Stringer A	East Side	M1 & P9
		West Side	M2
	Stringer C	East Side	M3
		West Side	M4
	Stringer D	East Side	M3
		West Side	M4
Stringer E	East Side	M3	
	West Side	M4	
West Fascia Stringer G	East Side	M5	
	West Side	M6 & P9	
Repair Detail "N" on Page 17 Cell B Span 19 Looking North	East Fascia Stringer A	East Side	N2
		West Side	N1
	Stringer C	East Side	N2
		West Side	N1
	Stringer D	East Side	N2
		West Side	N1
Stringer E	East Side	N2	
	West Side	N1	
West Fascia Stringer F	East Side	N2	
	West Side	N1	

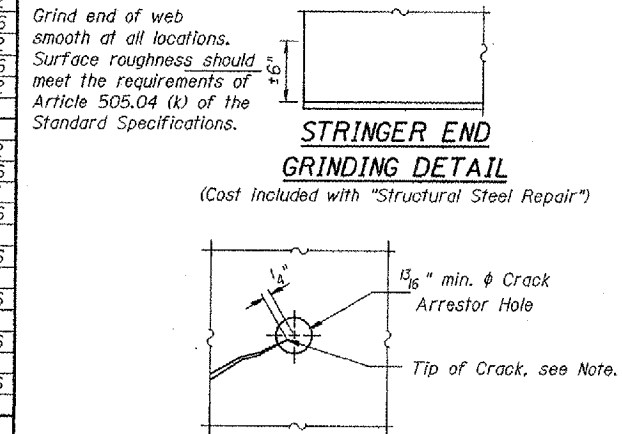

STRINGER END GRINDING DETAIL
 (Cost included with "Structural Steel Repair")

CRACK ARRESTOR HOLE DETAIL
 (Typ. at all stringer ends with cracks as req'd)

Note: Locate crack tip using liquid dye penetrant or magnetic particle testing. Drill $\frac{1}{8}$ " min. ϕ Crack Arrestor hole at the crack tip. After crack arrestor hole has been drilled, dye penetrant or magnetic particle testing shall be used to verify that the drilled hole has captured the crack tip. Cost shall be included with Structural Steel Repair.

BILL OF MATERIAL

ITEM	UNIT	QUANTITY
Structural Steel Repair	Pound	6430

DESIGNED **Drew Christopher**
 CHECKED **V.H.V.**
 DRAWN **Drew Christopher**
 CHECKED **P.S.J. V.H.V.**

December 6, 2002

EXAMINED **John A. Morris**
 ENGINEER OF STRUCTURAL SERVICES

PASSED

ENGINEER OF BRIDGES AND STRUCTURES

**ANGLE LOCATION TABLES
 AND GENERAL DETAILS**
F.A.I. 24 OVER OHIO RIVER
MASSAC COUNTY
S.N. 064-0035

STATE OF ILLINOIS
DEPARTMENT OF TRANSPORTATION

ROUTE NO.
FAI
21
FED. ROAD DIST.

CONTRACT: 98990
ROUTE: INTERSTATE 24
SECTION: (64-3B)1-6
COUNTY: MASSAC, IL; McCRACKEN, KY
SHEET 91 OF 99
FOR INFORMATION ONLY

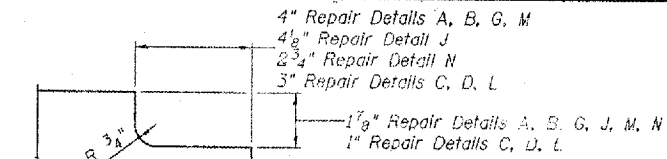

REPAIR ANGLE COPE DETAIL

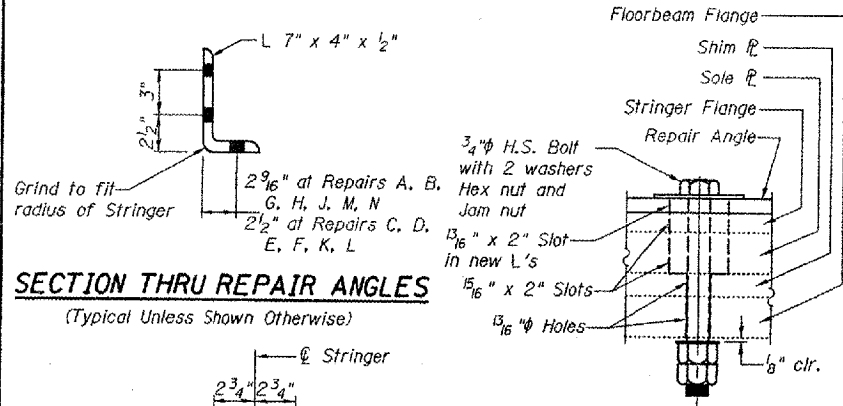

SECTION THRU REPAIR ANGLES
(Typical Unless Shown Otherwise)

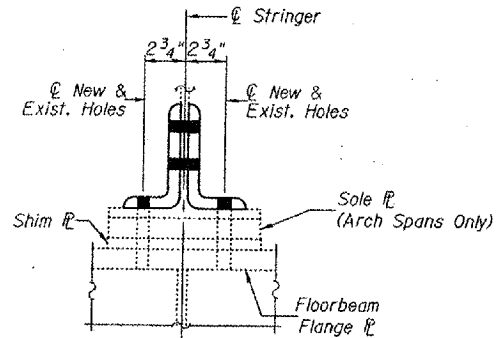

TYPICAL SECTION AT SLOTTED HOLES

TYPICAL END VIEW OF STRINGERS

Notes:
Thickness of floorbeam flange varies by location. In calculating required bolt length, allow 1/2" flange thickness for all locations in the girder spans (Repairs A, B, G, H, I, J, M, N). See Table for locations in the arch spans.

Thickness of shim varies by location. In calculating required bolt length, allow 2 3/4" shim thickness at Stringer D of the girder spans (Repairs A, B, G, H, J, M, N). Allow 1 1/8" for shim thickness at all other locations.

Thickness of sole varies by location. See table.

Span ID	Repair	Stringer	Flange Thickness	Sole Thickness
4	C, D	A, B, C, E, F, G D	1 3/8" 1 7/8"	1 3/8" 2 1/16"
	E, F	A, B, C, E, F, G D	1 1/8" 1 7/8"	1 7/8" 2 1/16"
13	E, F	A, B, C, E, F, G D	1" 1"	2" 2 15/16"
	K, L	A, G B, F C, D, E	1 3/8" 1" 1"	1 5/8" 2" 2 15/16"

DESIGNED Drew Christopher
CHECKED V.H.V.
DRAWN Drew Christopher
CHECKED P.S.J. V.H.V.

December 6, 2002
EXAMINED John A. Morris
PASSED
ENGINEER OF STRUCTURAL SERVICES
ENGINEER OF BRIDGES AND STRUCTURES

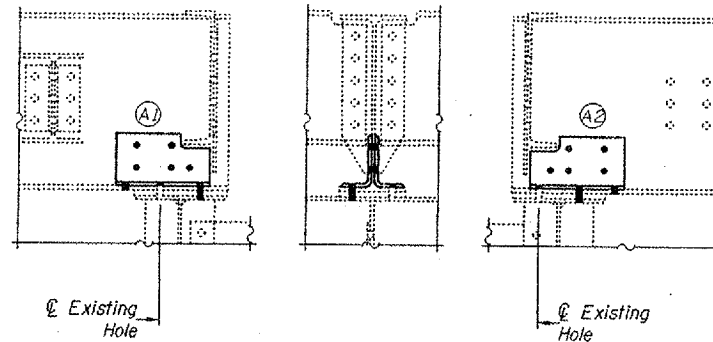

STRINGERS C, D & E
(Stringers A & G Similar)

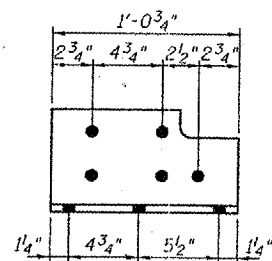

ANGLE A1

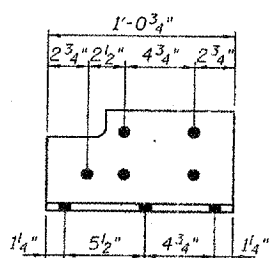

ANGLE A2

REPAIR DETAIL "A"

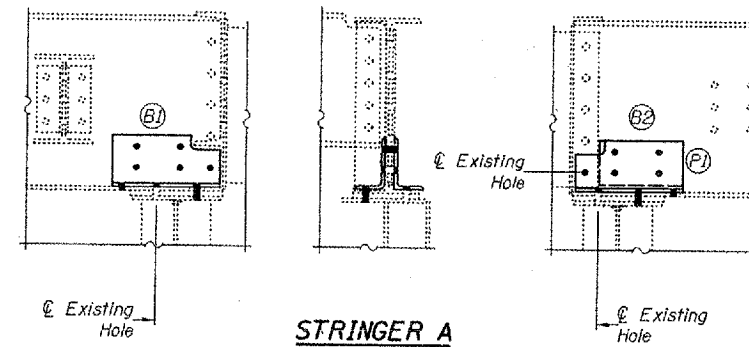

STRINGER A

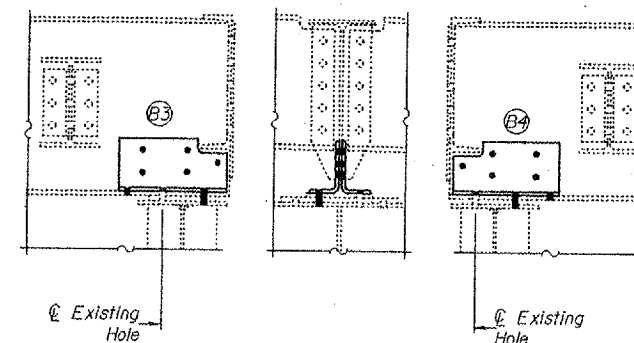

STRINGERS C, D & E

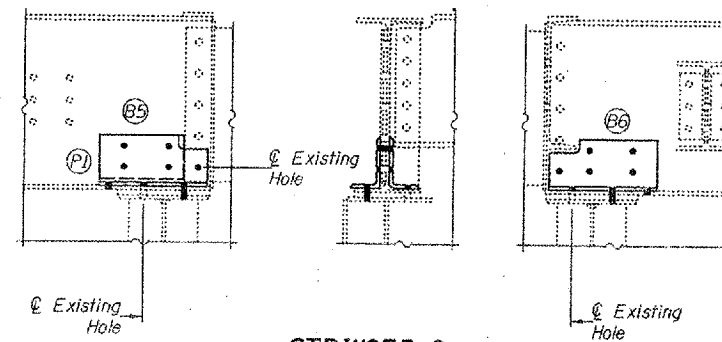

STRINGER G

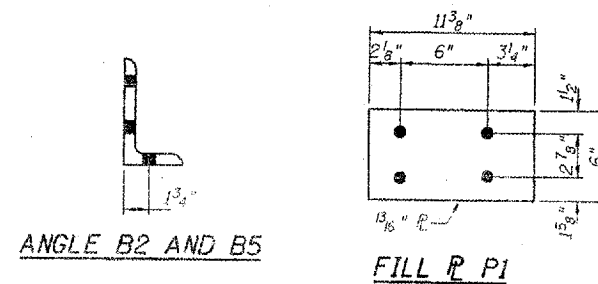

ANGLE B2 AND B5

REPAIR DETAIL "B"

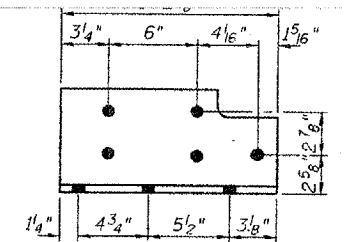

ANGLE B1 AND B5

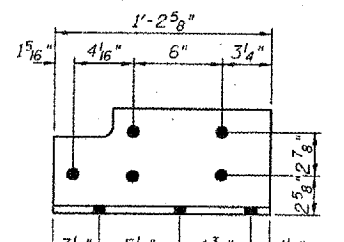

ANGLE B2 AND B6

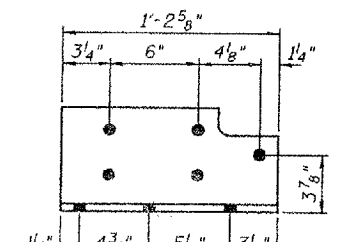

ANGLE B3

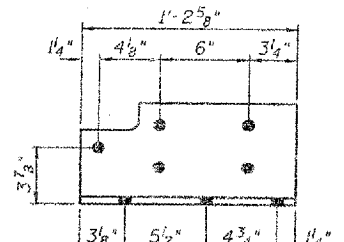

ANGLE B4

STRINGER END GENERAL DETAILS
REPAIR DETAIL "A" AND "B"
F.A.I. 24 OVER OHIO RIVER
MASSAC COUNTY
S.N. 064-0035

STATE OF ILLINOIS
DEPARTMENT OF TRANSPORTATION

CONTRACT: 98990
ROUTE: INTERSTATE 24
SECTION: (64-3B) I-6
COUNTY: MASSAC, IL; McCracken, KY
SHEET 92 OF 99
FOR INFORMATION ONLY

ROUTE NO.
F.A.I.
24
FED. ROAD DIST. NO.

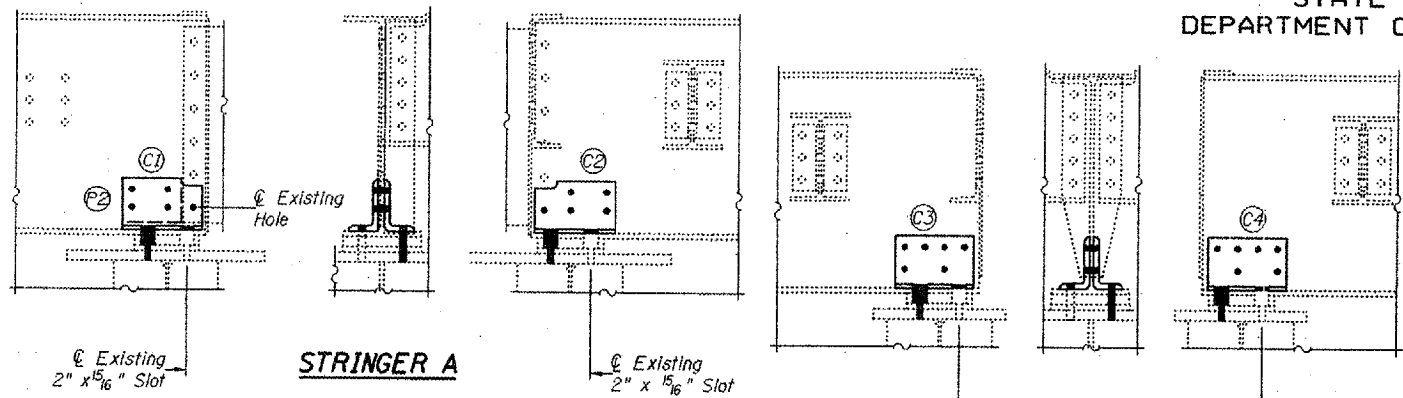

STRINGER A

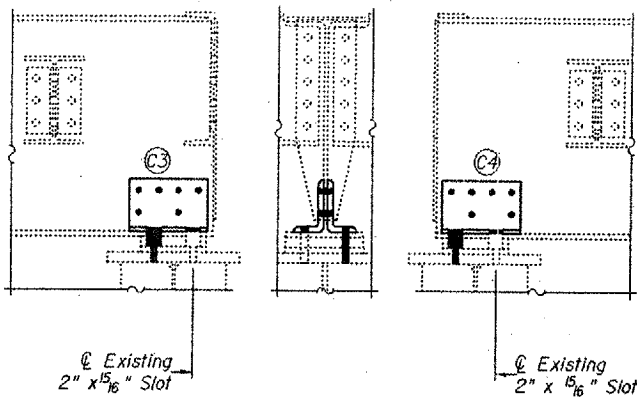

STRINGERS B, C, E, AND F

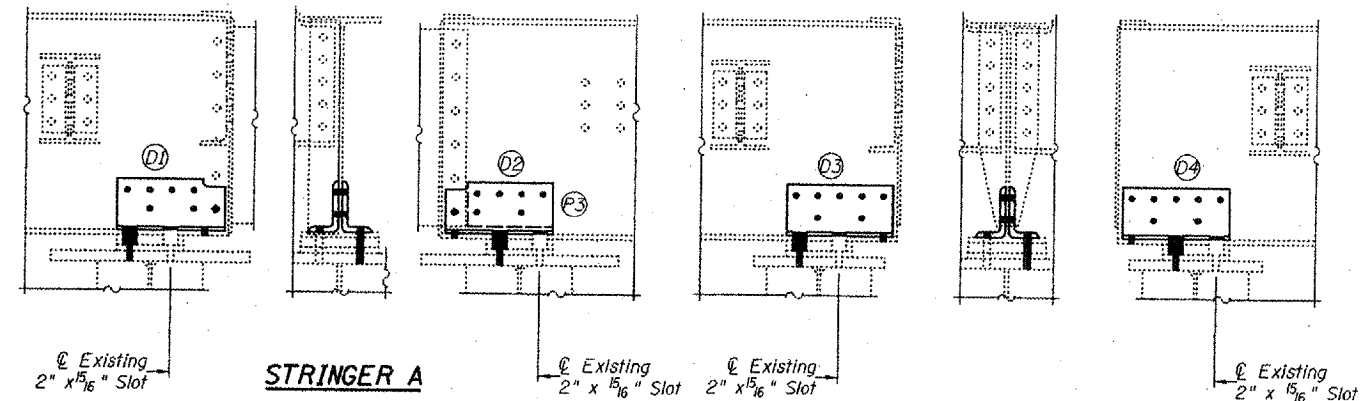

STRINGER A

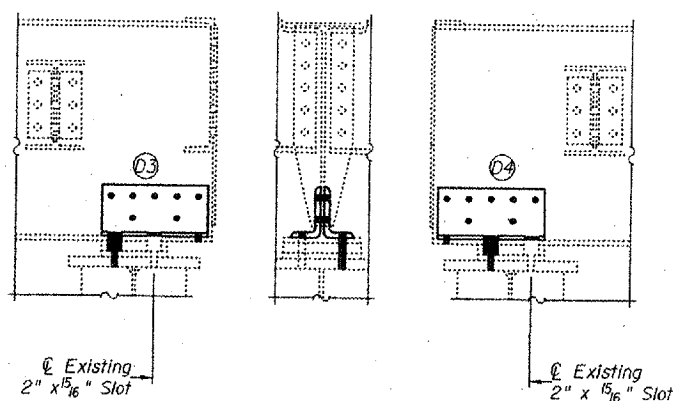

STRINGERS B, C, E, AND F

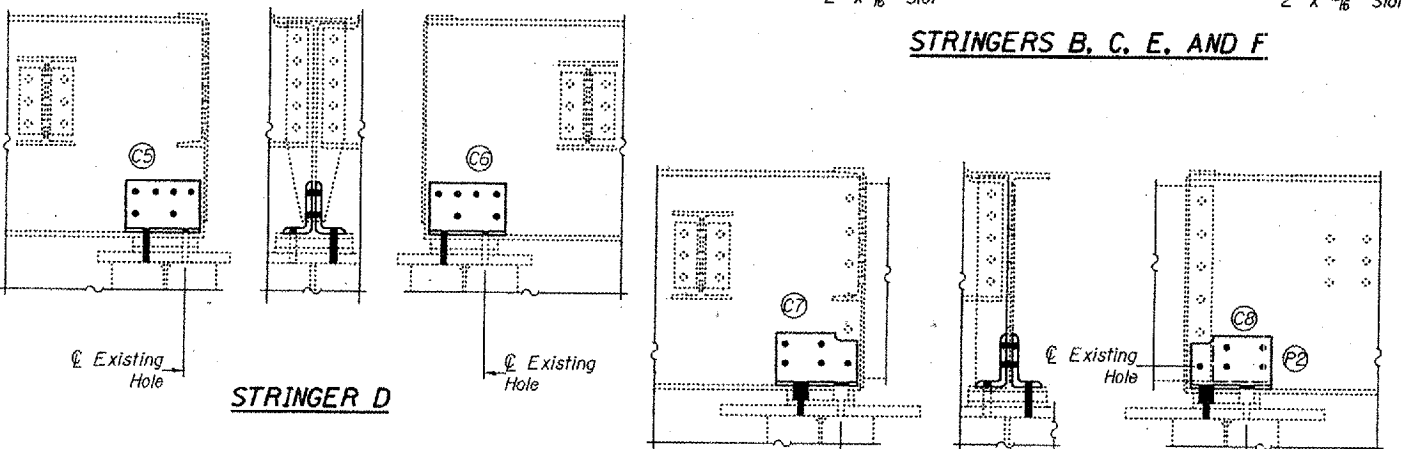

STRINGER D

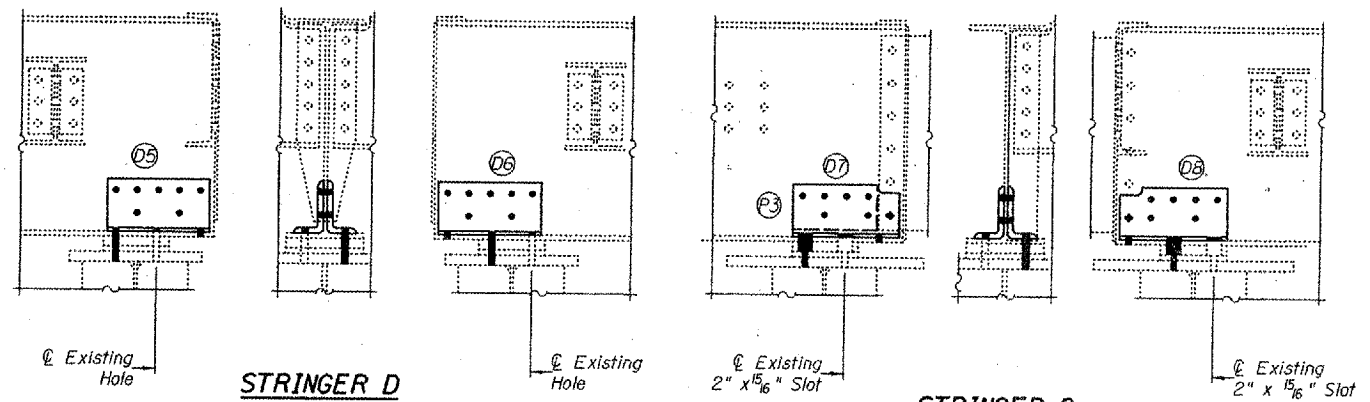

STRINGER D

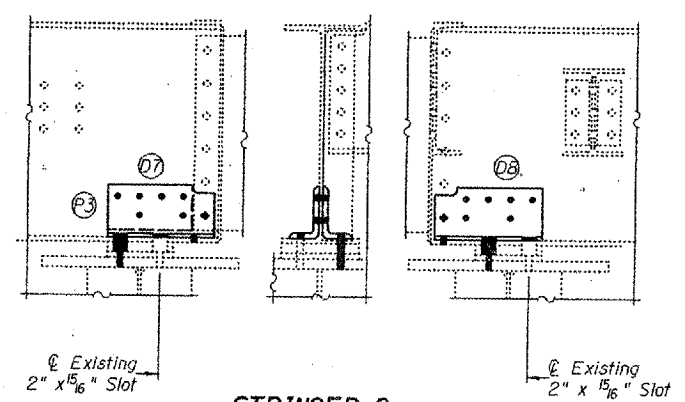

STRINGER G

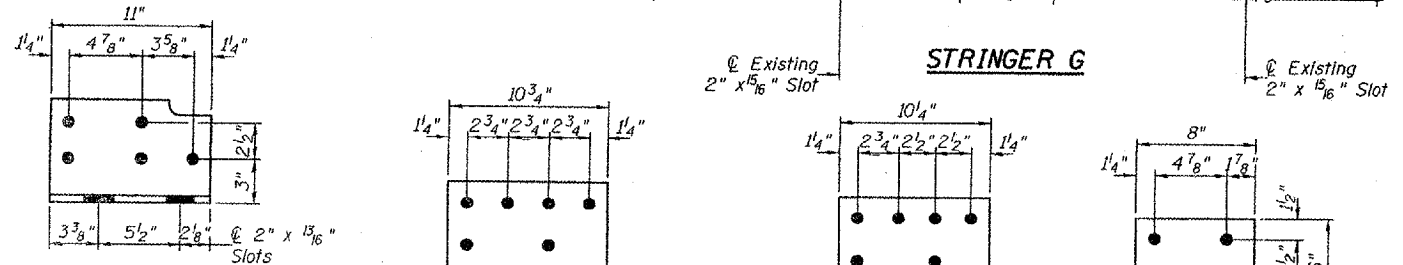

STRINGER G



ANGLE C1 AND C7

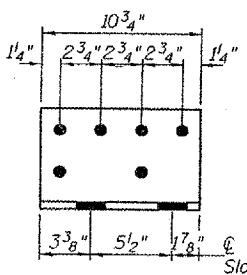

ANGLE C3

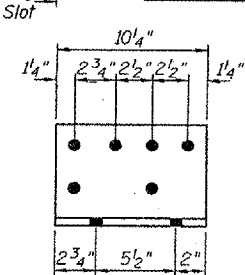

ANGLE C5

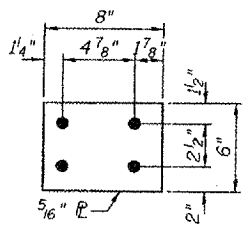

FILL P P2

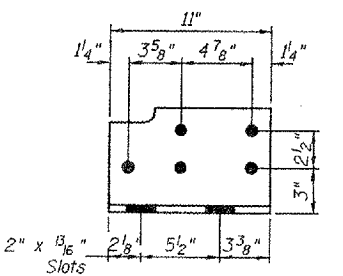

ANGLE C2 AND C8

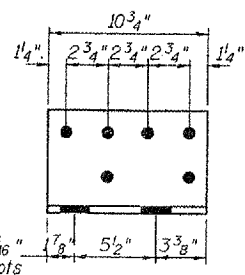

ANGLE C4

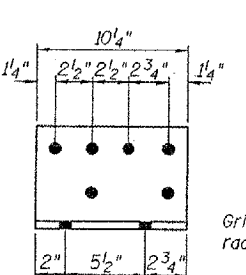

ANGLE C6

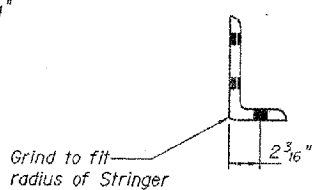

ANGLE C1 AND C8

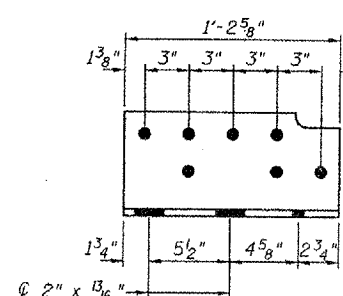

ANGLE D1 AND D7

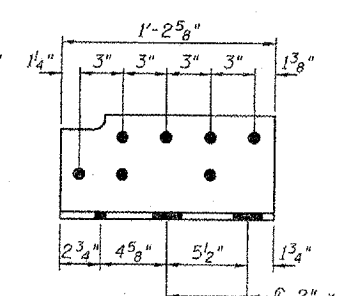

ANGLE D2 AND D8

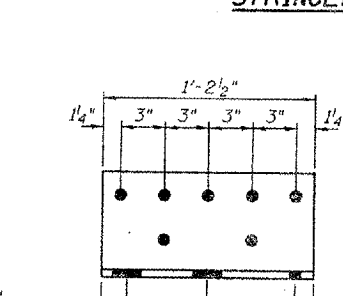

ANGLE D3

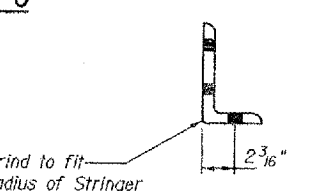

ANGLE D2 AND D7

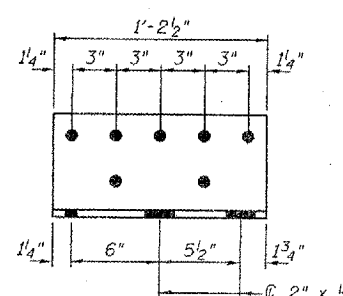

ANGLE D4

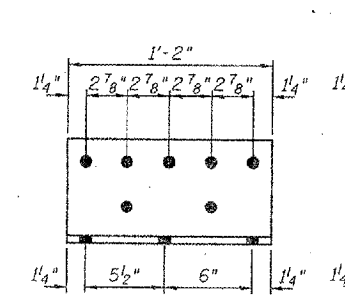

ANGLE D5

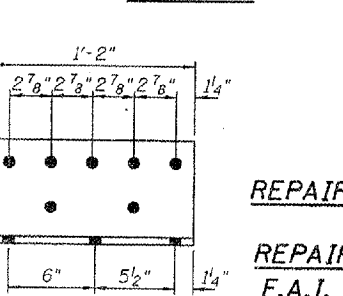

ANGLE D6

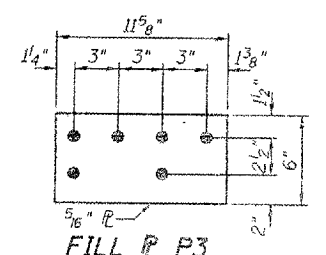

FILL P P3

DESIGNED Drew Christopher
CHECKED V.H.V.
DRAWN Drew Christopher
CHECKED P.S.J. V.H.V.

December 6, 2002
EXAMINED John A. Morris
ENGINEER OF STRUCTURAL SERVICES
PASSED

REPAIR DETAIL "C"

REPAIR DETAIL "D"

REPAIR DETAILS "C" AND "D"
F.A.I. 24 OVER OHIO RIVER
MASSAC COUNTY
S.N. 064-0035

STATE OF ILLINOIS
DEPARTMENT OF TRANSPORTATION

ROUTE NO.
F.A.I.
24
FED. ROAD DIST.

CONTRACT: 98990
ROUTE: INTERSTATE 24
SECTION: (64-3B) I-6
COUNTY: MASSAC, IL; McCRACKEN, KY
SHEET 93 OF 94
FOR INFORMATION ONLY

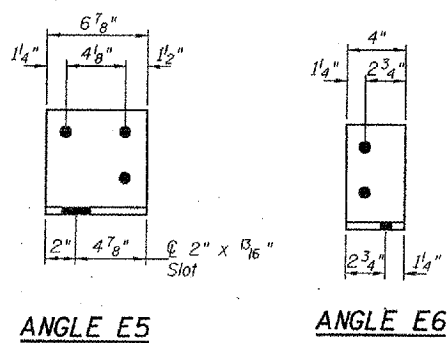
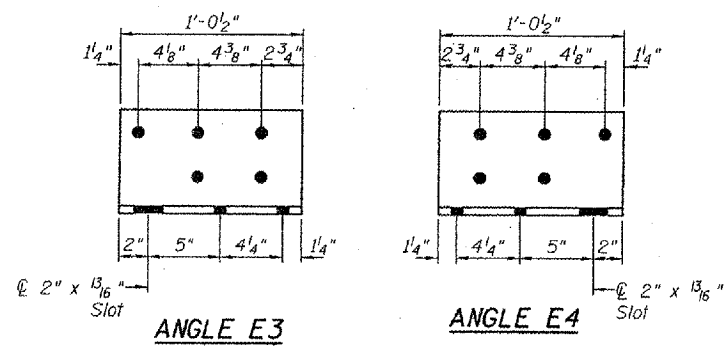
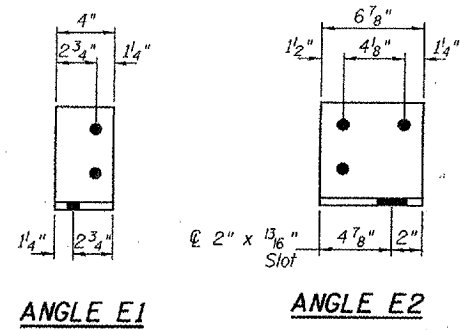
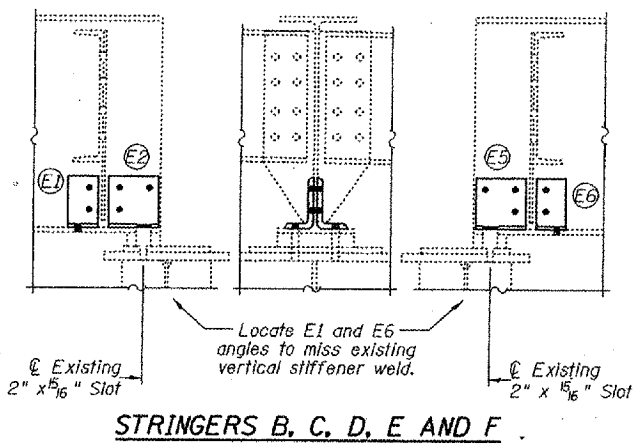
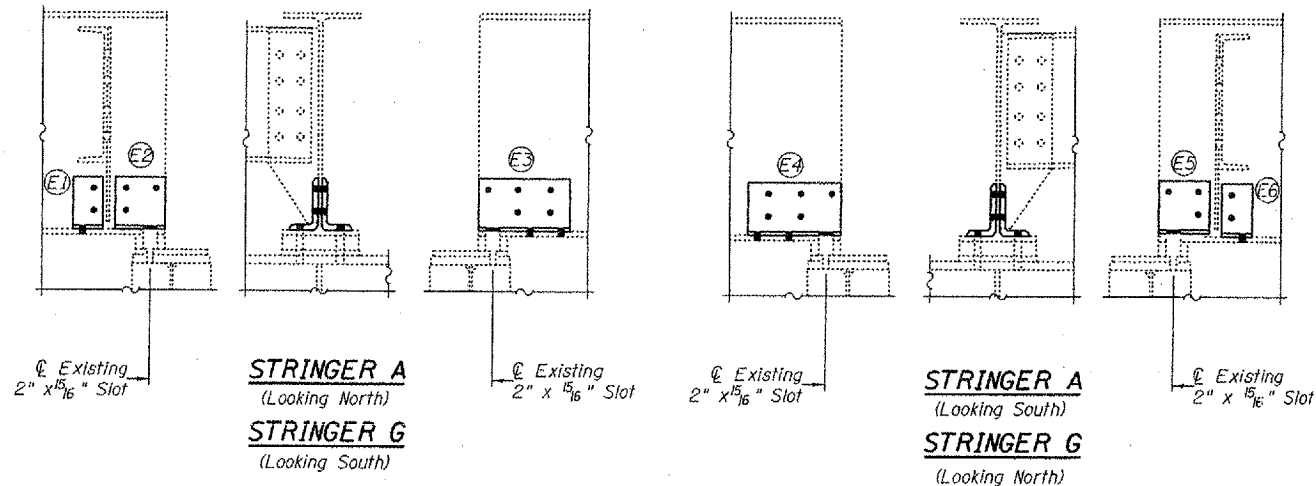

REPAIR DETAIL "E"

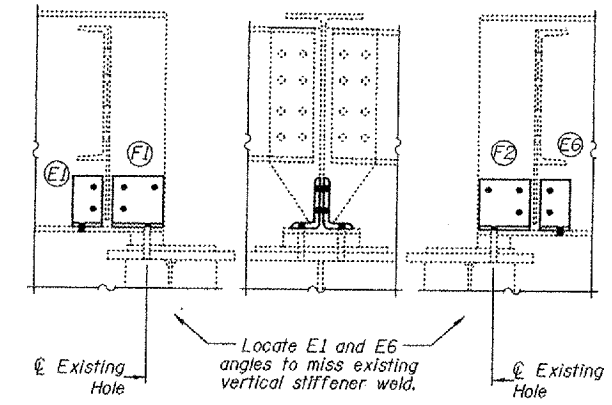

STRINGERS B, C, D, E AND F

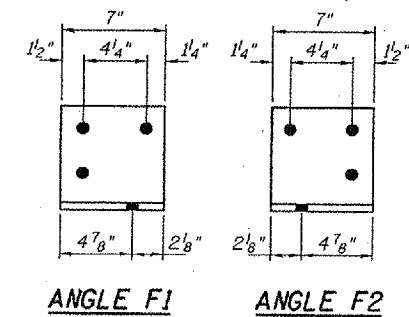

REPAIR DETAIL "F"

DESIGNED Drew Christopher
CHECKED V.H.V.
DRAWN Drew Christopher
CHECKED P.S.J. V.H.V.

December 6, 2002
EXAMINED John A. Morris
PASSED
ENGINEER OF BRIDGES AND STRUCTURES

REPAIR DETAIL "E" AND "F"
F.A.I. 24 OVER OHIO RIVER
MASSAC COUNTY
S.N. 064-0035

STATE OF ILLINOIS
DEPARTMENT OF TRANSPORTATION

ROUTE NO.
FAI
24
FED. ROAD DIST.

CONTRACT: 98990
ROUTE: INTERSTATE 24
SECTION: (64-3B)1-6
COUNTY: MASSAC, IL; McCRACKEN, KY
SHEET 94 OF 99
FOR INFORMATION ONLY

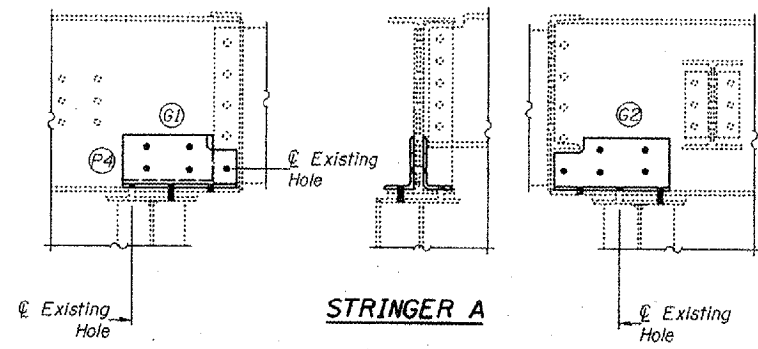

STRINGER A

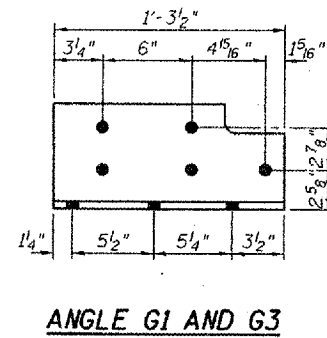

ANGLE G1 AND G3

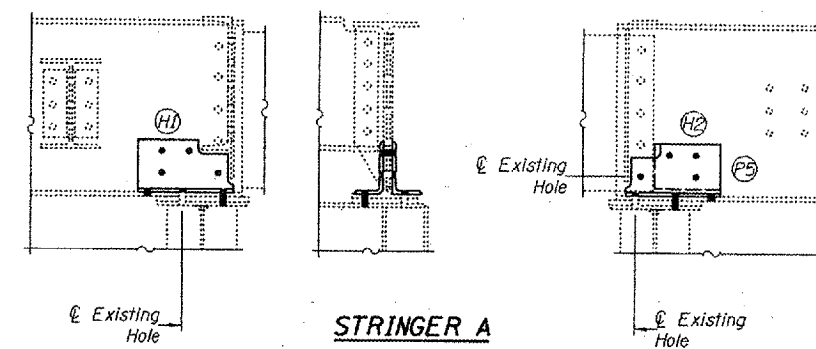

STRINGER A

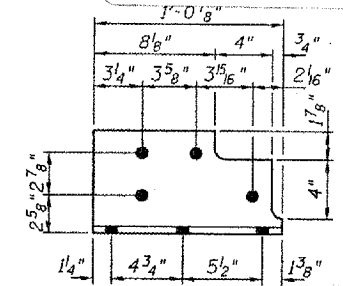

ANGLE H1 AND H5

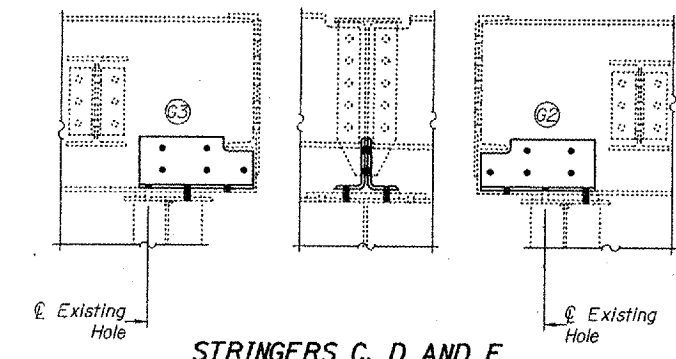

STRINGERS C, D AND E

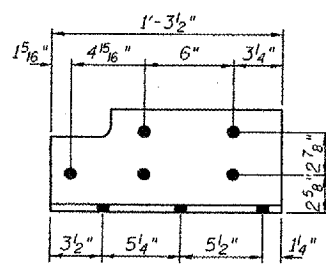

ANGLE G2 AND G4

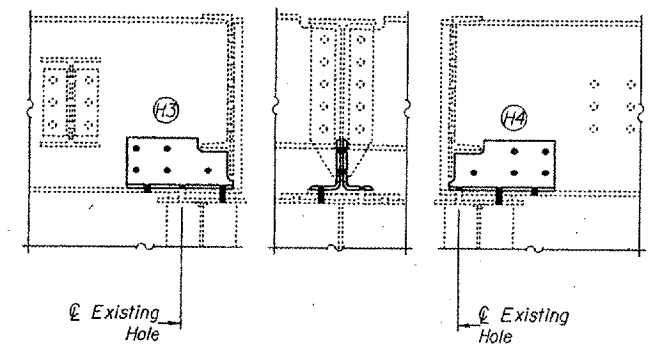

STRINGER C, D AND E

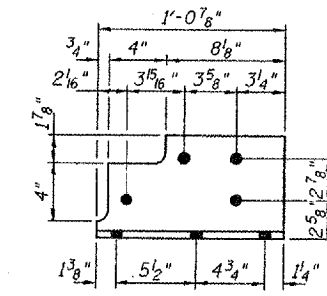

ANGLE H2 AND H6

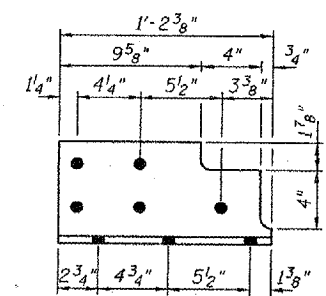

ANGLE H3

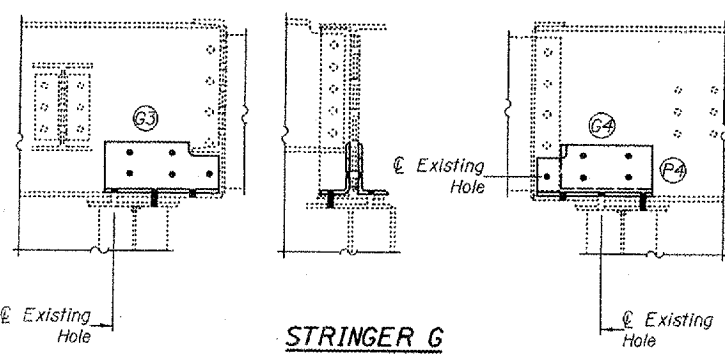

STRINGER G

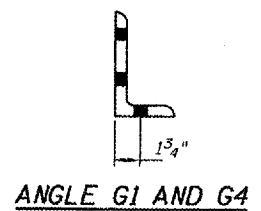

ANGLE G1 AND G4

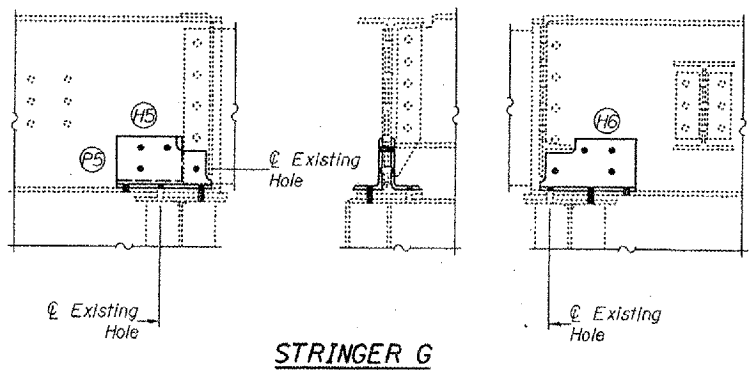

STRINGER G

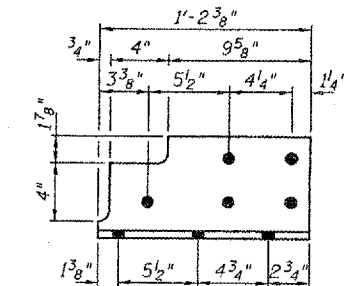

ANGLE H4

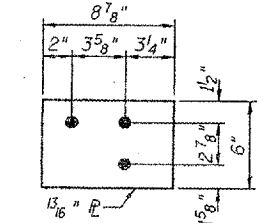

FILL P P5

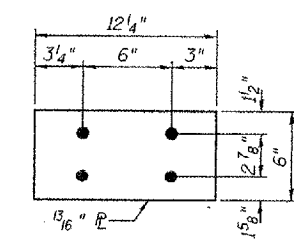

FILL P P4

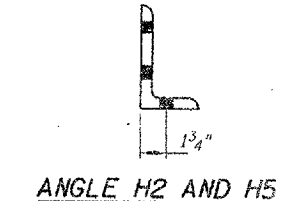

ANGLE H2 AND H5

REPAIR DETAIL "G"

REPAIR DETAIL "H"

3/4" Radius on all re-entrant cuts.

DESIGNED Drew Christopher
CHECKED V.H.V.
DRAWN Drew Christopher
CHECKED P.S.J. V.H.V.

December 6, 2002
EXAMINED John A. Morris
PASSED
ENGINEER OF STRUCTURAL SERVICES
ENGINEER OF BRIDGES AND STRUCTURES

REPAIR DETAIL "G" AND "H"
F.A.I. 24 OVER OHIO RIVER
MASSAC COUNTY
S.N. 064-0035

STATE OF ILLINOIS
DEPARTMENT OF TRANSPORTATION

CONTRACT: 98990
ROUTE: INTERSTATE 24
SECTION: (64-3B) I-6
COUNTY: MASSAC, IL; McCRACKEN, KY
SHEET 95 OF 99
FOR INFORMATION ONLY

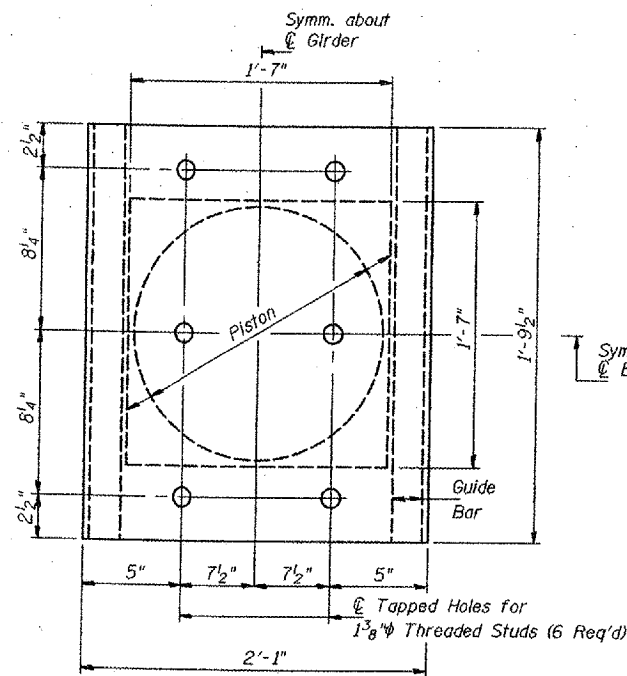

**NORTH ABUTMENT PLAN
TOP BEARING PLATE AND PISTON**

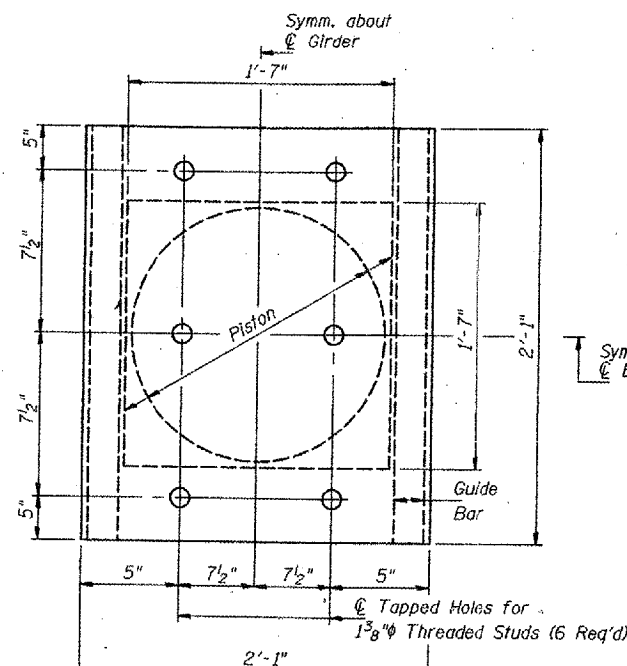

**SOUTH ABUTMENT PLAN
TOP BEARING PLATE AND PISTON**

* As an alternate to the bolted connection shown, the guide bars may be connected to the top bearing plate by groove welds or the guide bars and top bearing plate may be fabricated as a single piece.
** Weld may be omitted if Base Cylinder is recessed into Bottom Plate.

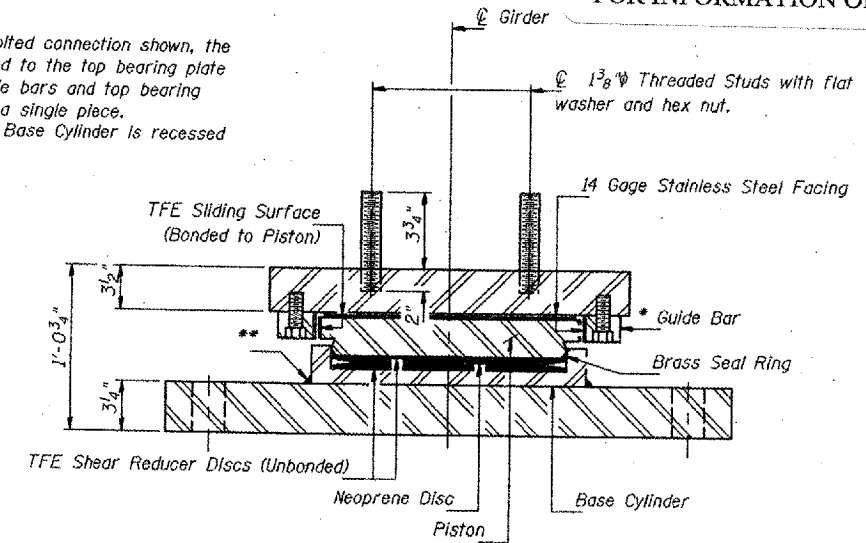

BEARING ASSEMBLY

BEARING DATA		
	N. Abut.	S. Abut.
RR (K)	508.0	490.8
R4 (K)	171.5	170.0
RIMP (K)	26.5	26.7
RR+4+1 (K)	706.0	687.5
Expansion Length	300'-0"	600'-0"

Notes: Provide 2-1/8" x 1'-9" x 2'-11" adjusting shims per Bearing. Included in quantity for "Structural Steel Repair" on sheet 19 of 22. The Contractor is responsible for adjusting dimensions as required in the field for the actual floating bearing used. Dimensions to be adjusted shall be submitted to the Engineer for approval prior to fabrication of bearings.
Bottom bearing plate thickness was determined by using a pot diameter of 19 inches.
Cost of field drilling is included with Structural Steel Repair. For Anchor Bolt installation details, see sheet 22 of 22.
Minimum combined jack capacity = 500 Tons

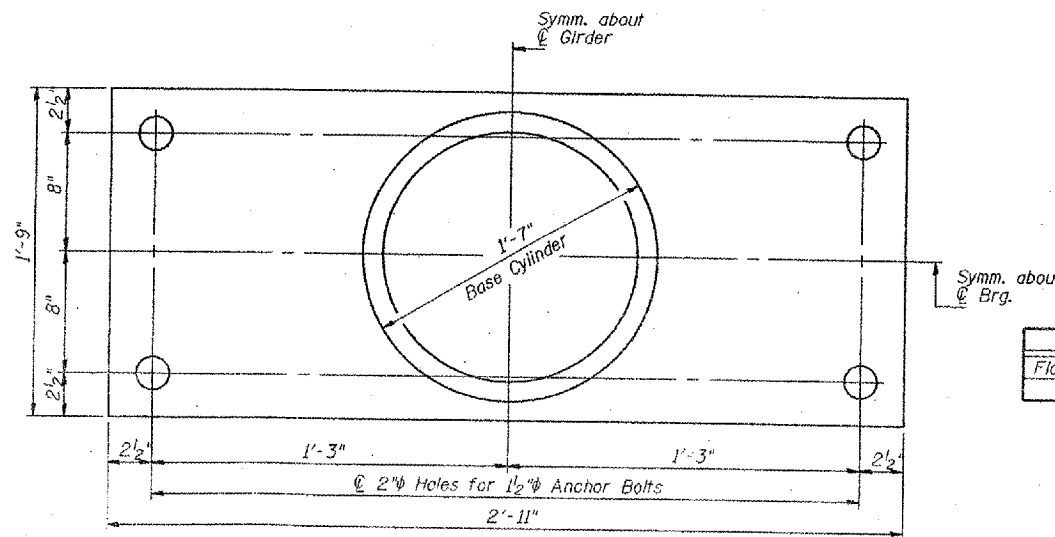

PLAN - BOTTOM BEARING PLATE

BILL OF MATERIAL

Item	Unit	Total
Floating Bearings, Guided Expansion, 700 k	Each	4

**REPAIR DETAIL "Q"
FLOATING BEARINGS
F.A.I. 24 OVER OHIO RIVER
MASSAC COUNTY
S.N. 064-0035**

DESIGNED P.S.J.
CHECKED V.H.V.
DRAWN Drew Christopher
CHECKED P.S.J. V.H.V.

December 6, 2002
EXAMINED **John A. Morris**
PASSED
ENGINEER OF STRUCTURAL SERVICES
ENGINEER OF BRIDGES AND STRUCTURES

STATE OF ILLINOIS
DEPARTMENT OF TRANSPORTATION

CONTRACT: 98990
ROUTE: INTERSTATE 24
SECTION: (64-3B)1-6
COUNTY: MASSAC, IL; McCRACKEN, KY
SHEET 96 OF 99
FOR INFORMATION ONLY

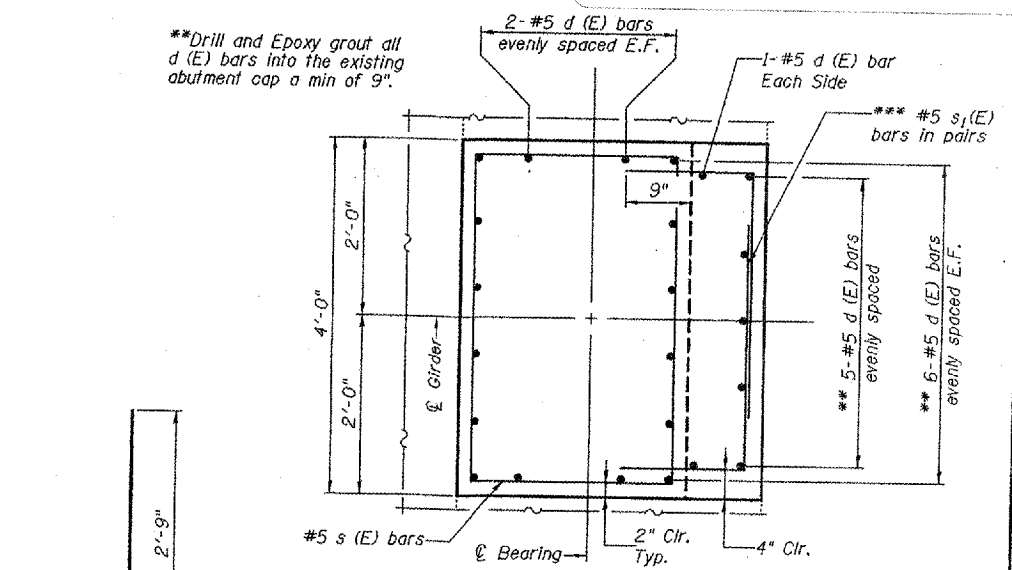
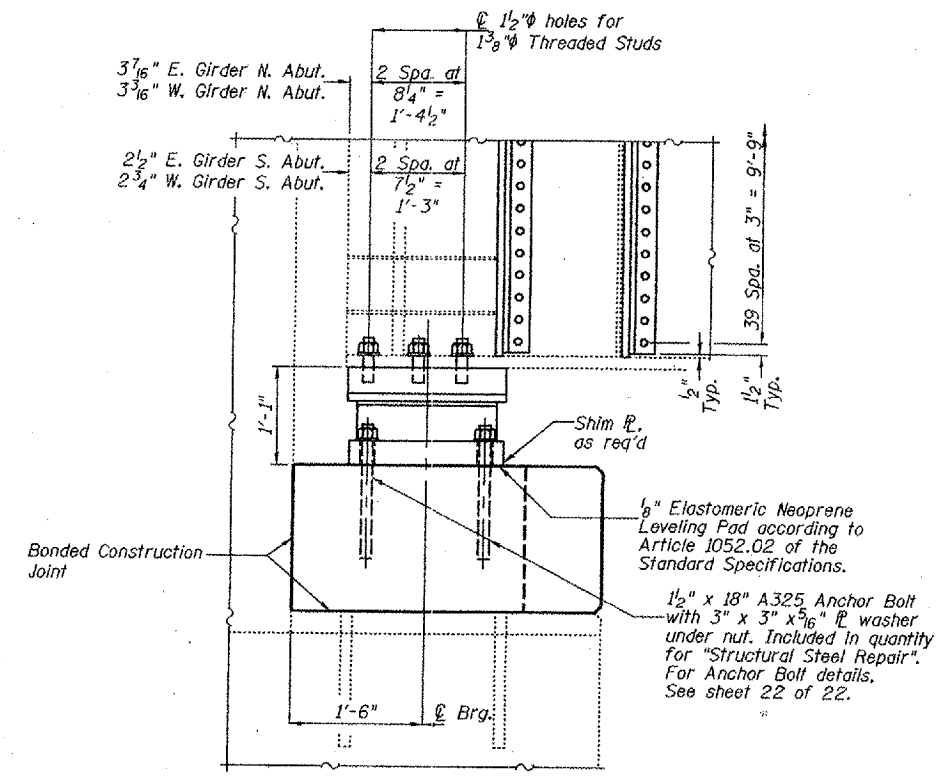
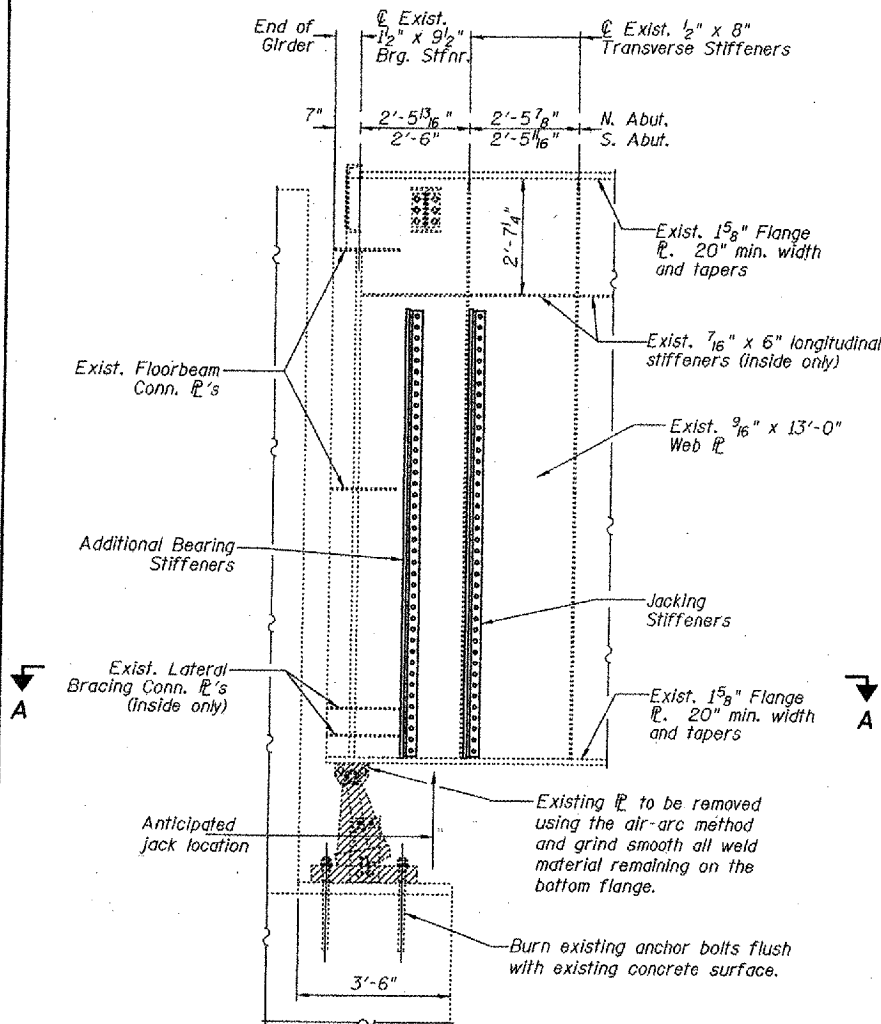

BEARING REMOVAL
Install Additional bearing stiffeners and jacking stiffeners prior to jacking operations. Additional bearing stiffeners included in quantity for "Structural Steel Repair". Cost for jacking stiffeners included with "Jacking and Cribbing".

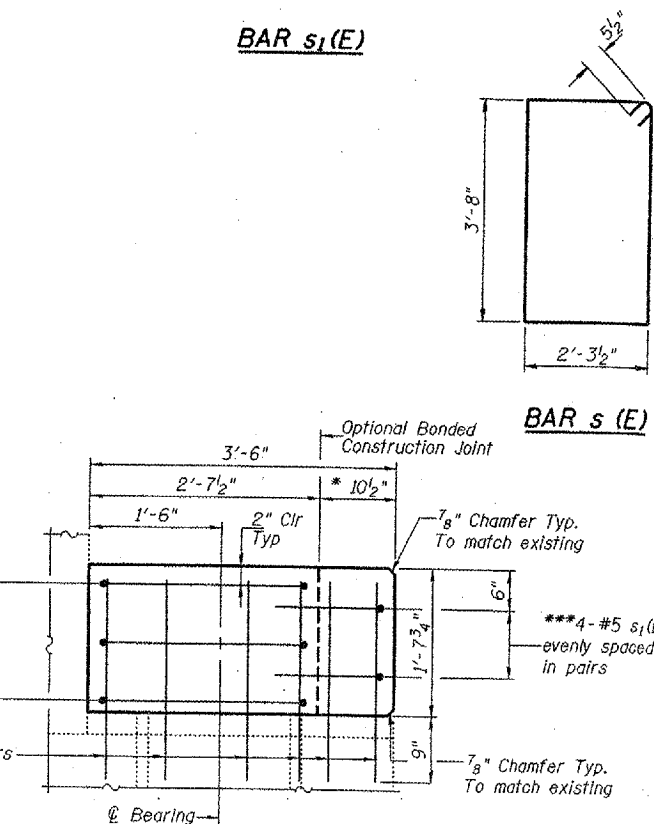
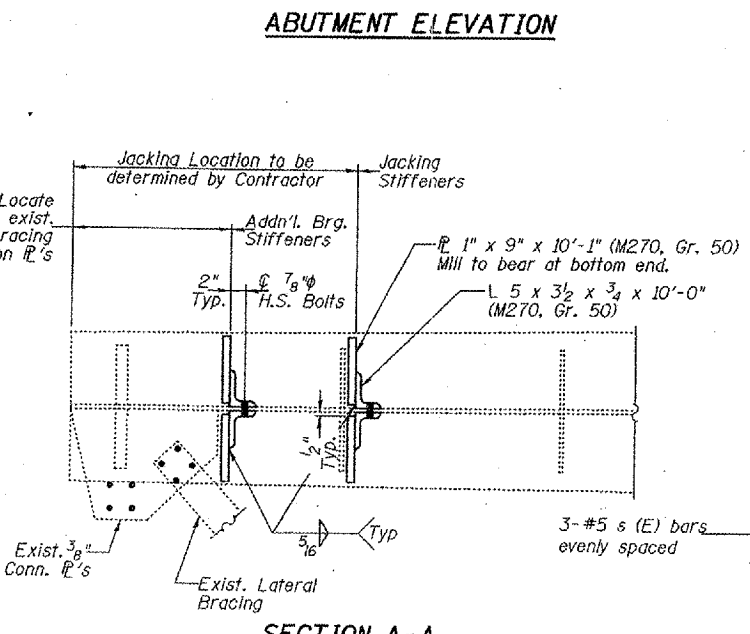

ABUTMENT PEDESTAL PLAN

ABUTMENT ELEVATION

ABUTMENT PEDESTAL ELEVATION

Min Bar Lap
#5 = 2'-2"

BILL OF MATERIAL
(Two Abutments)

Bar	No.	Size	Length	Shape
d (E)	92	#5	2'-3"	—
s (E)	12	#5	12'-10"	□
s1 (E)	16	#5	4'-2"	L
Concrete Structures				
			Cu. Yd.	3.4
Structural Steel Repair			Pounds	4640
Reinforcement Bars, Epoxy Coated			Pound	450

Reinforcement bars designated (E) shall be epoxy coated.

Epoxy grout bars in accordance with Article 584 of the Standard Specifications. Cost is included in cost of Reinforcement Bars, Epoxy Coated.

REPAIR DETAIL "O"
ABUTMENT BEARING REPLACEMENT
F.A.I. 24 OVER OHIO RIVER
MASSAC COUNTY
S.N. 064-0035

DESIGNED P.S.J.
CHECKED V.H.V.
DRAWN Drew Christopher
CHECKED P.S.J. V.H.V.

December 6, 2002
EXAMINED John A. Morris
PASSED
ENGINEER OF BRIDGES AND STRUCTURES

STATE OF ILLINOIS
DEPARTMENT OF TRANSPORTATION

ROUTE	SECTION	COUNTY	TOTAL SHEETS	SHEET NO.
FAI. 24	*	MASSAC	99	97

FED. ROAD DIST. NO. 7 ILLINOIS
*(64-3B) I-6
CONTRACT NO. 98990

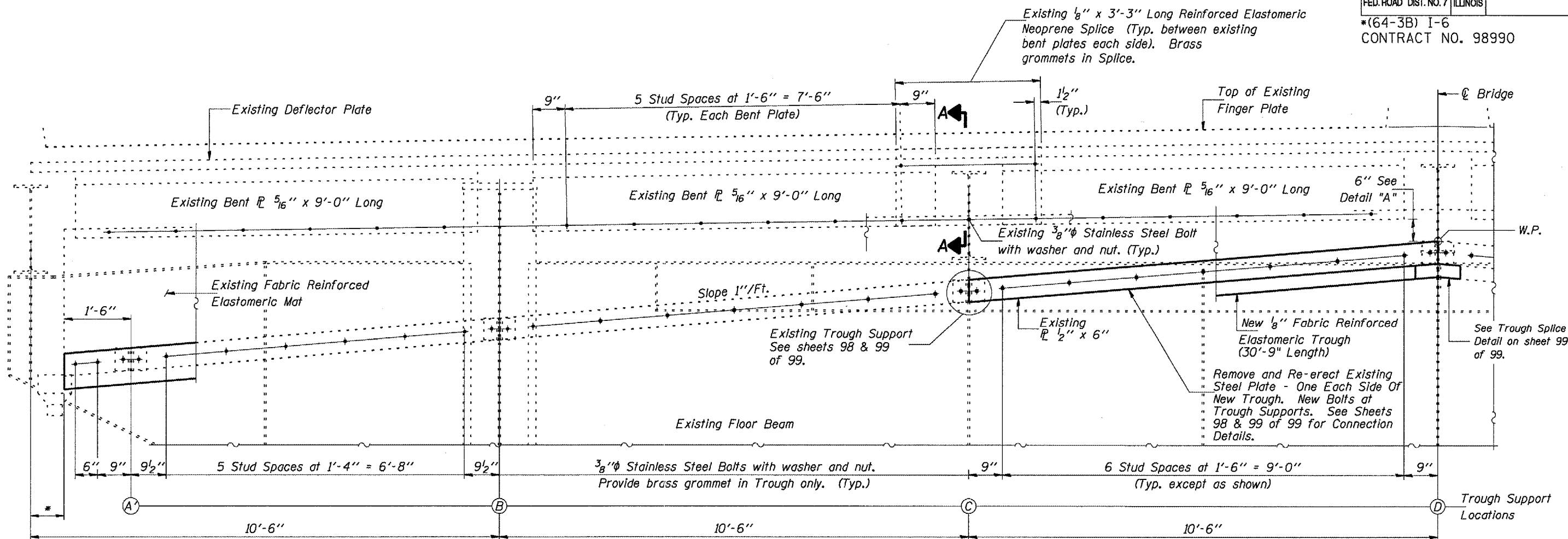

CROSS SECTION

(Pier 8 Looking North, North Side & looking South, South Side)

* To be determined in field.

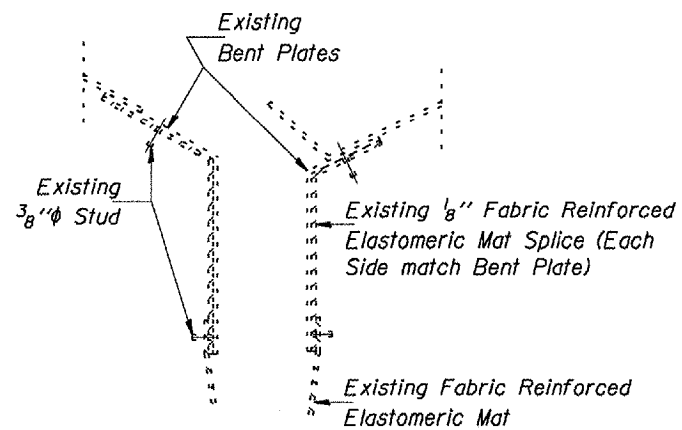

SECTION A-A
FOR INFORMATION ONLY

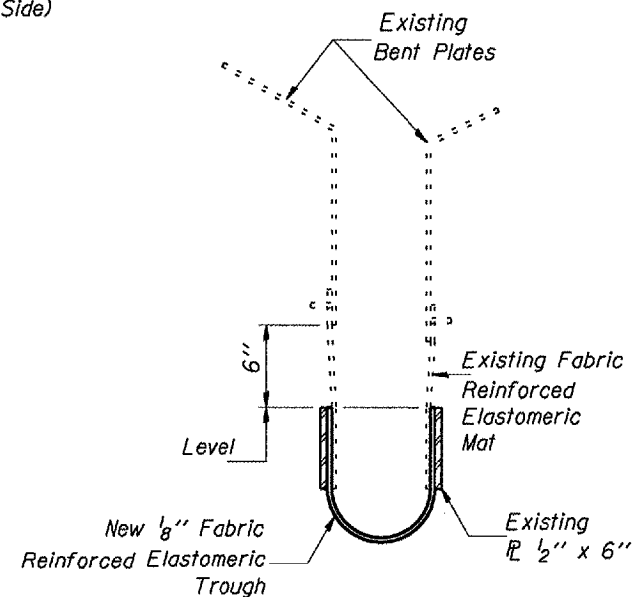

DETAIL "A"

TROUGH DETAILS
F.A.I. 24 OVER OHIO RIVER
MASSAC COUNTY
S.N. 064-0035

STATE OF ILLINOIS
DEPARTMENT OF TRANSPORTATION

ROUTE	SECTION	COUNTY	TOTAL SHEETS	SHEET NO.
F.A.I. 24	*	MASSAC	99	98

FED. ROAD DIST. NO. 7 ILLINOIS

*(64-3B) I-6
CONTRACT NO. 98990

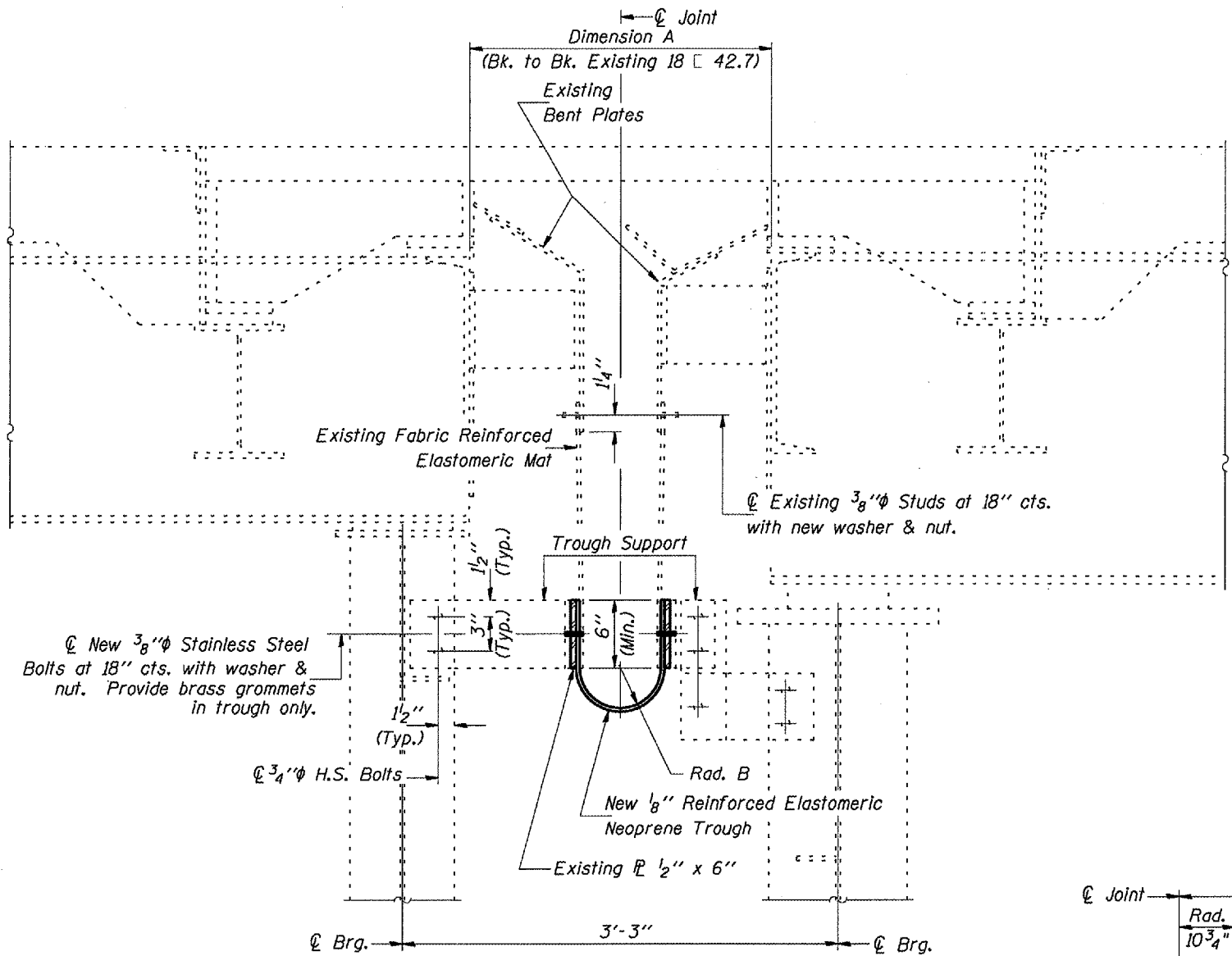

SECTION THRU JOINT

Notes:

A total of 54 new bolts are required: (22 x 2) in new trough, with washers, nuts, and brass grommets
4 in trough supports, with washers and nuts
6 in trough splice with washers, nuts, and grommets

The Contractor shall use care to avoid damage of the existing fabric reinforced elastomeric mat which overlaps the trough. If the mat is damaged, the Contractor shall replace the mat to the same specifications as the existing, at the direction of the Engineer.

TABLE OF DIMENSIONS

LOCATION	DIMENSION AT TEMPERATURE (F.)									
	20°		40°		60°		80°		100°	
	Dim. A	Rad. B	Dim. A	Rad. B	Dim. A	Rad. B	Dim. A	Rad. B	Dim. A	Rad. B
Pier #8	3'-2 3/4"	8 7/8"	3'-0 3/8"	7 1/8"	2'-10"	6 1/2"	2'-7 5/8"	5 5/16"	2'-5 5/16"	4 1/8"

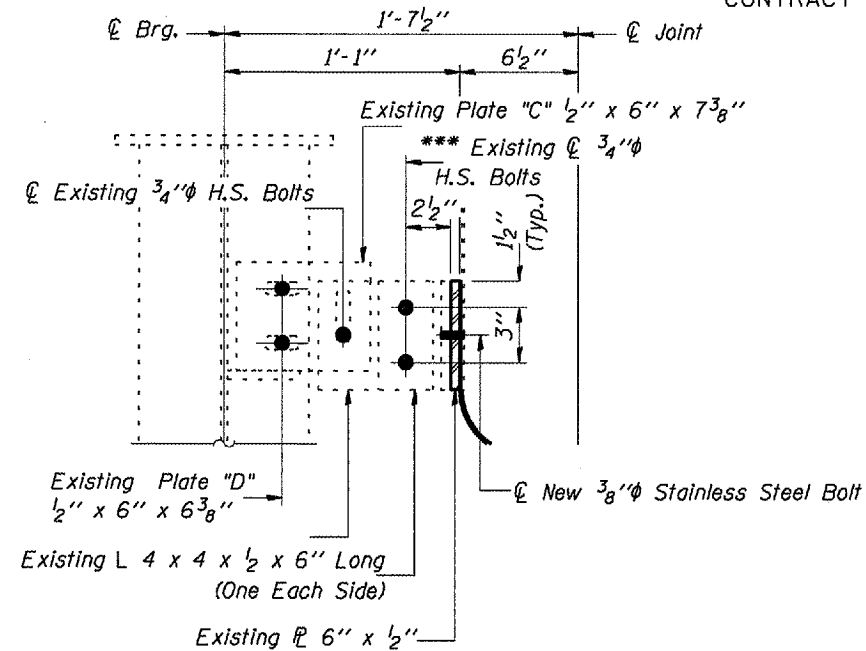

**TYPE 3 CONNECTION
SPAN 8, LOCATION C ***

* SEE LOCATION C (STRINGER C) ON SHEET 97 OF 99.

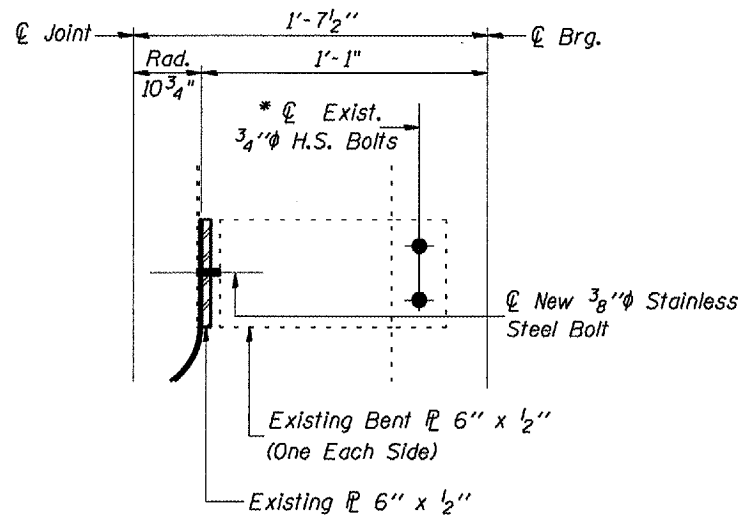

**TYPE 1 CONNECTION
SPAN 9, LOCATION C ***

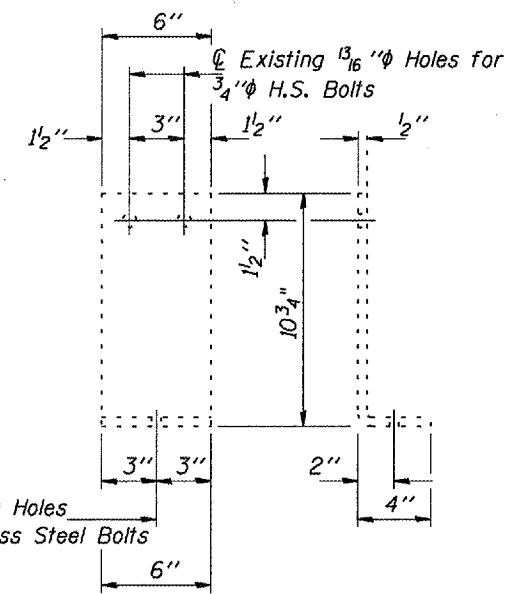

**EXISTING BENT PLATE DETAIL
FOR INFORMATION ONLY**

STATE OF ILLINOIS
DEPARTMENT OF TRANSPORTATION

ROUTE	SECTION	COUNTY	TOTAL SHEETS	SHEET NO.
F.A.I. 24	*	MASSAC	99	99

FED. ROAD DIST. NO. 7 ILLINOIS

*(64-3B) I-6
CONTRACT NO. 98990

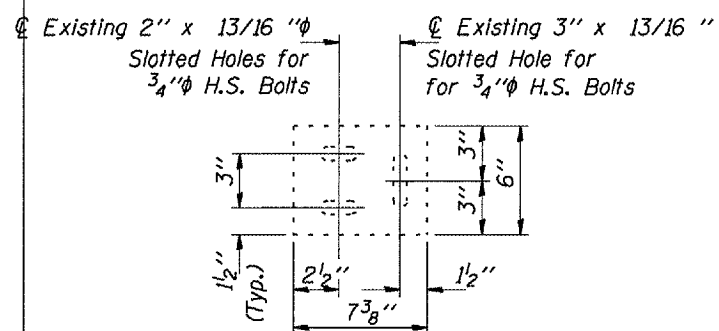

EXISTING PLATE "C"
FOR INFORMATION ONLY

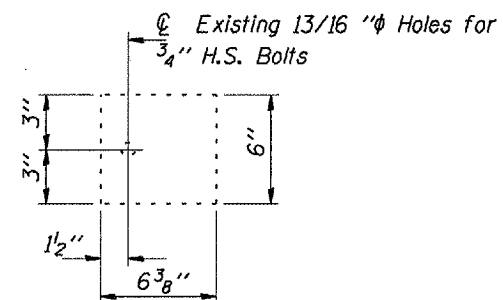

EXISTING PLATE "D"
FOR INFORMATION ONLY

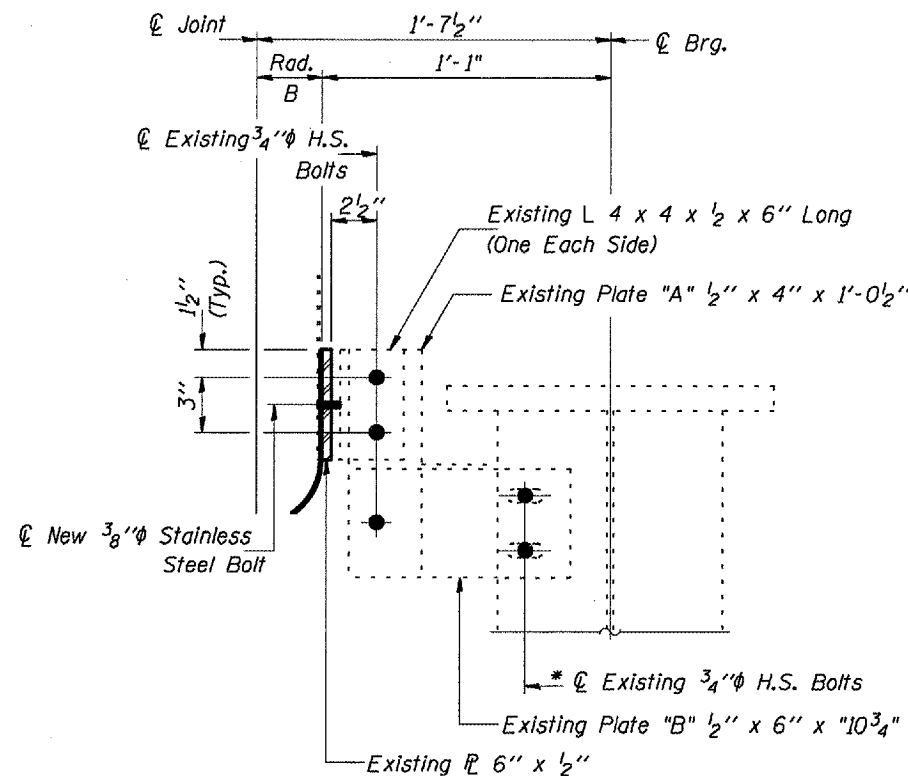

TYPE 2 CONNECTION
LOCATION D

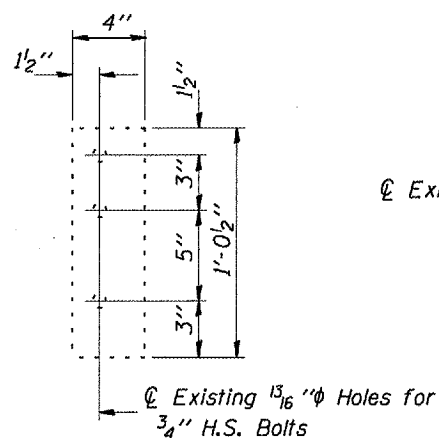

EXISTING PLATE "A"
FOR INFORMATION ONLY

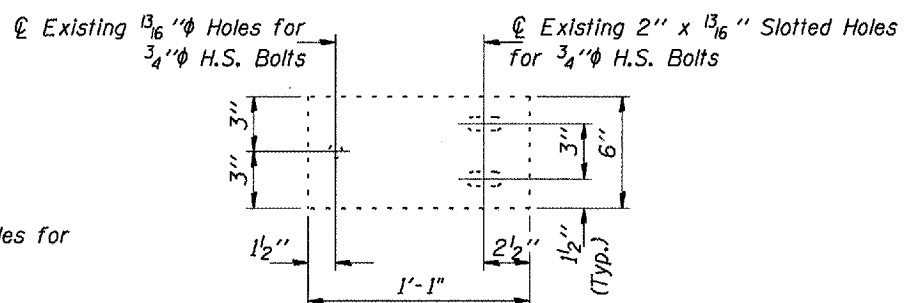

EXISTING PLATE "B"
FOR INFORMATION ONLY

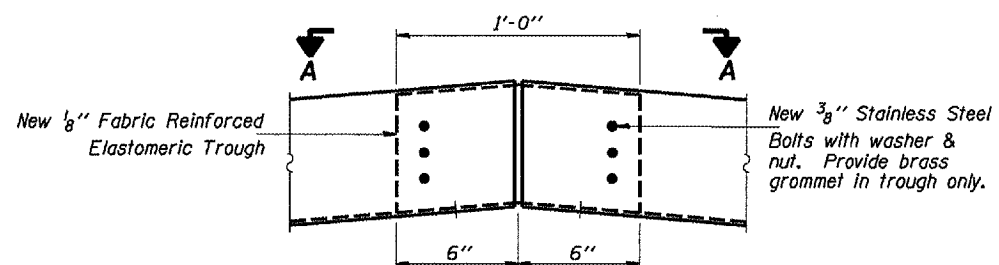

TROUGH SPLICE DETAIL



VIEW A-A

TROUGH DETAILS
F.A.I. 24 OVER OHIO RIVER
MASSAC COUNTY
S.N. 064-0035