

POLE DISCONNECT SWITCH DETAIL FOR ROADWAY LIGHTING
NOT TO SCALE

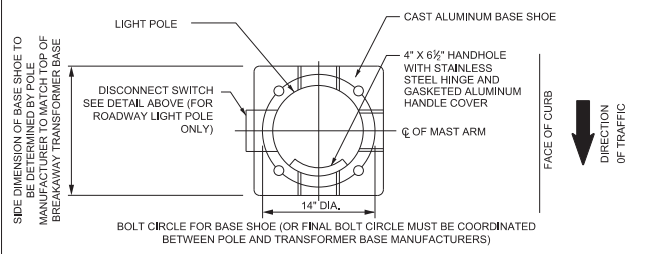

BASE SHOE PLAN DETAIL/HANDHOLE AND DISCONNECT SWITCH ORIENTATION PLAN FOR ROADWAY LIGHTING
NOT TO SCALE

Computer Filename 06-07-03.DGN	Chicago Department of Aviation/O'Hare Modernization Program Design and Construction Standards	Issue Date: 6/30/2010 Detail No.: 06-07-03	REV 4
-----------------------------------	--	---	----------

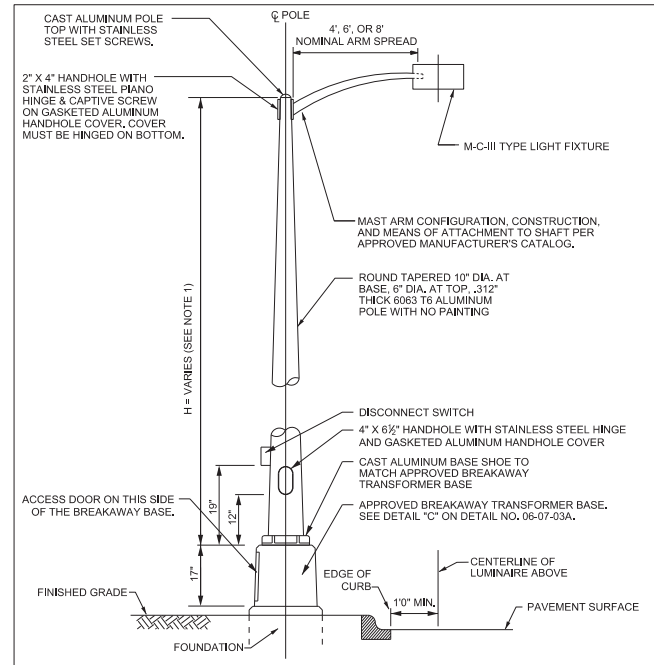

TYPICAL LIGHT POLE DETAIL FOR ROADWAY LIGHTING (SHOWING SINGLE MAST ARM ONLY)
NOT TO SCALE

Computer Filename 06-07-02A.DGN	Chicago Department of Aviation/O'Hare Modernization Program Design and Construction Standards	Issue Date: 6/30/2010 Detail No.: 06-07-02A	REV 2
------------------------------------	--	--	----------

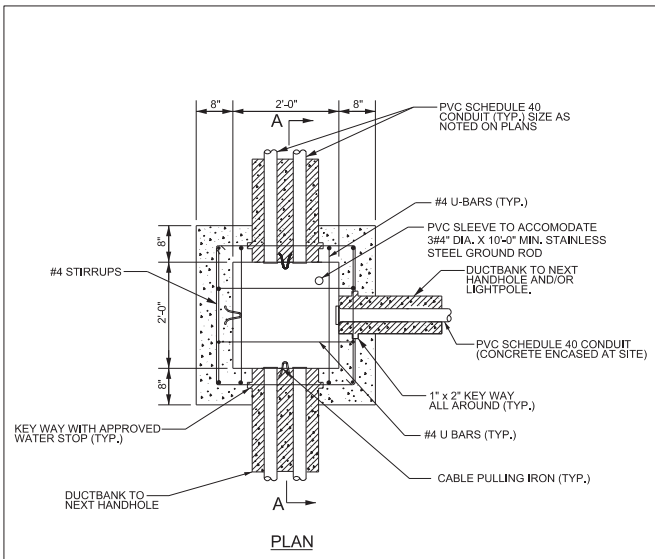

TYPICAL ROADWAY LIGHTING HANDHOLE PLAN (NOT TO SCALE)

NOTES:
1. 3/4" DIA. X 16" LONG ANCHOR BOLTS FOR HANDHOLE FRAME, (4 REQUIRED) 2" PROJECTION AND 2" HOOK REQUIRED. FOR PLACEMENT, SEE DETAIL NO. 6-06-08R.
2. FOR SECTION A-A, SEE DETAIL NO. 6-06-08R.

Computer Filename 06-06-07R.dgn	Chicago Department of Aviation/O'Hare Modernization Program Design and Construction Standards	Issue Date: 08/31/2009 Detail No.: 6-06-07R	REV 0
------------------------------------	--	--	----------

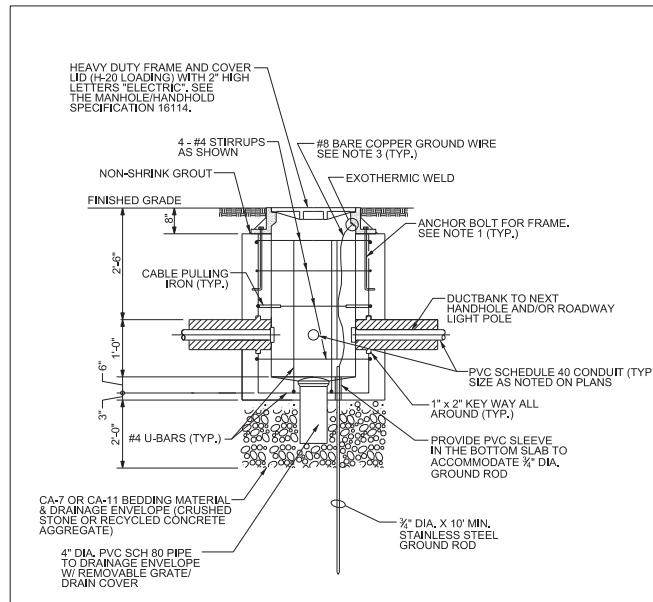

SECTION A-A TYPICAL ROADWAY LIGHTING HANDHOLE (NOT TO SCALE)

NOTES:
1. 3/4" DIA. X 16" LONG ANCHOR BOLTS FOR HANDHOLE FRAME, (4 REQUIRED) 2" PROJECTION AND 2" HOOK REQUIRED.
2. FRAME SHALL HAVE DRILLED HOLES FOR ANCHOR BOLTS, ACCEPTABLE FRAME AND COVER ARE NEENAH NO. R-1795-E, EAST JORDAN IRONWORKS NO. 8055 OR CAMPBELL FOUNDRY.
3. BARE COPPER GROUND WIRE SHALL BE CONNECTED TO THE GROUND ROD AND HANDHOLE COVER FRAME VIA EXOTHERMIC WELDS.

Computer Filename 06-06-08R.dgn	Chicago Department of Aviation/O'Hare Modernization Program Design and Construction Standards	Issue Date: 9/30/2011 Detail No.: 6-06-08R	REV 3
------------------------------------	--	---	----------

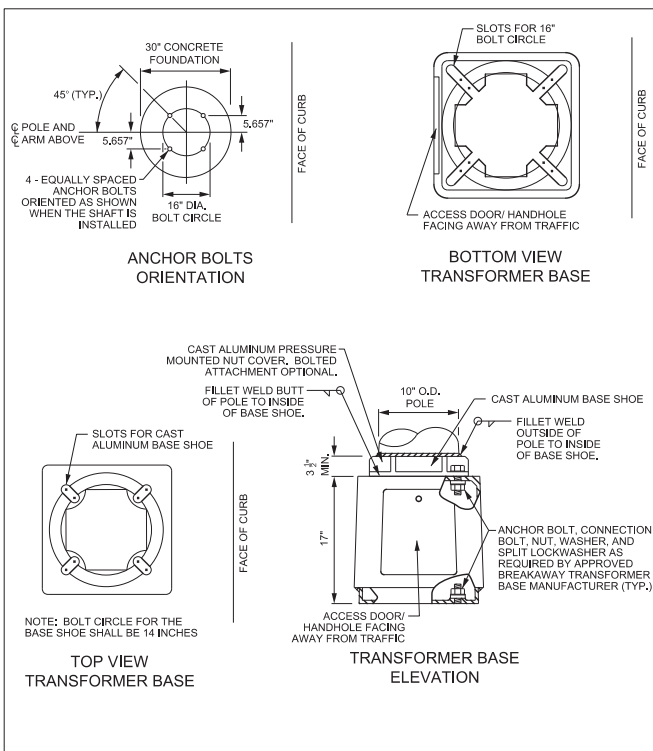

DETAIL "C" - BREAKAWAY TRANSFORMER BASE FOR ROADWAY LIGHTING
NOT TO SCALE

Computer Filename 06-07-03.DGN	Chicago Department of Aviation/O'Hare Modernization Program Design and Construction Standards	Issue Date: 6/30/2010 Detail No.: 06-07-03A	REV 0
-----------------------------------	--	--	----------

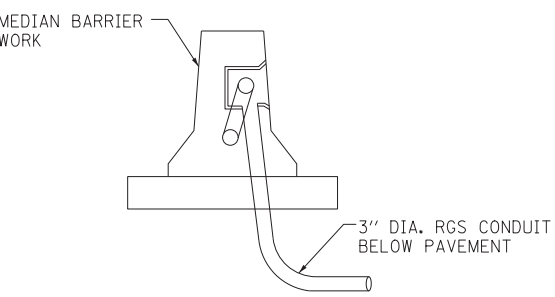

JUNCTION BOX EMBEDDED IN CONCRETE BARRIER
N.T.S.

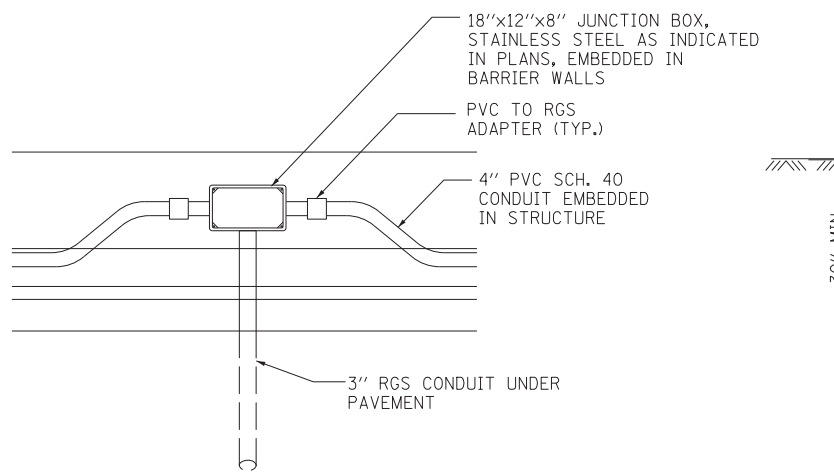

SINGLE DUCT BANK DETAIL
N.T.S.

	USER NAME = mali	DESIGNED - HS	REVISED -
	PLOT SCALE = *SCALE*	DRAWN - KK	REVISED -
	PLOT DATE = 10/5/2012	CHECKED - HS	REVISED -
		DATE - 10-19-2012	REVISED -

Computer Filename 06-07-03.DGN	Chicago Department of Aviation/O'Hare Modernization Program Design and Construction Standards	Issue Date: 6/30/2010 Detail No.: 06-07-03A	REV 0
-----------------------------------	--	--	----------

STATE OF ILLINOIS DEPARTMENT OF TRANSPORTATION		ELECTRICAL DETAILS	
SCALE: NONE	SHEET NO. OF SHEETS	STA.	TO STA.

F.A.P. RTE.	SECTION	COUNTY	TOTAL SHEETS	SHEET NO.
330	0105-WRS	COOK	537	298
CONTRACT NO. 60P35				
ILLINOIS FED. AID PROJECT				