

PLAN VIEW
APPROACH SLAB OR BRIDGE APPROACH SHOULDER
 (STANDARD 609001 or 609006)

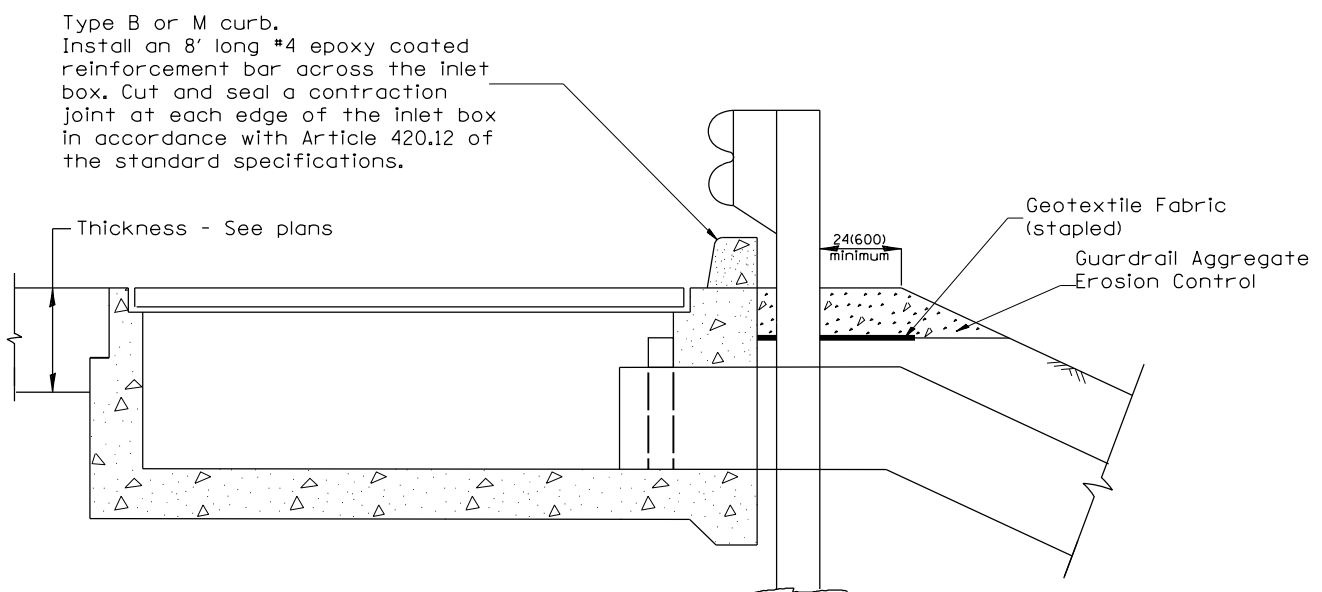

TYPICAL SECTION AT INLETS
TYPE E & F (STANDARD 610001)

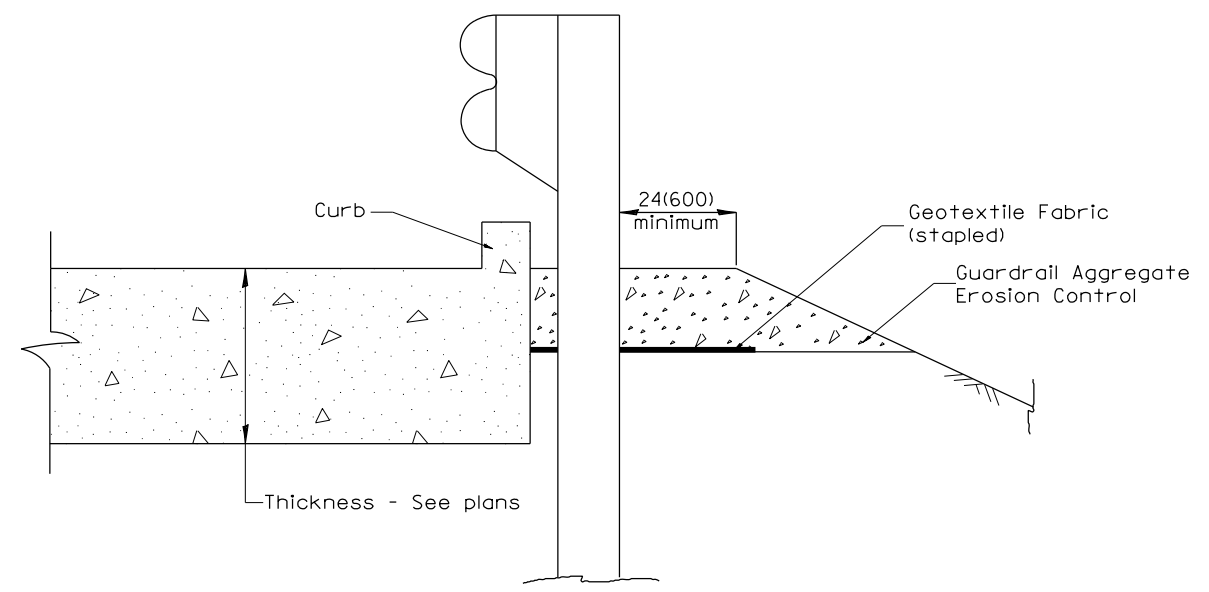

SECTION A-A
TYPICAL SECTION WITH BRIDGE APPROACH CURB

All dimensions are in inches (millimeters) unless otherwise noted.

STATE OF ILLINOIS DEPARTMENT OF TRANSPORTATION				GUARDRAIL EROSION CONTROL TREATMENTS				SHT. 2 OF 2
				NOT TO SCALE				CADD STD. 630101-D4
F.A.P. RTE.	SECTION	COUNTY	TOTAL SHEETS	SHEET NO.				
313	7-2 ; 6-1	HENDERSON	976	569	CONTRACT NO. 68409			
FED. ROAD DIST. NO.		ILLINOIS FED. AID PROJECT						