

F.A.P. RTE.	SECTION	COUNTY	TOTAL SHEETS	SHEET NO.
322	11-13	CHRISTIAN	437	56
STA.		TO STA.		
FED. ROAD DIST. NO.	ILLINOIS	FED. AID PROJECT		

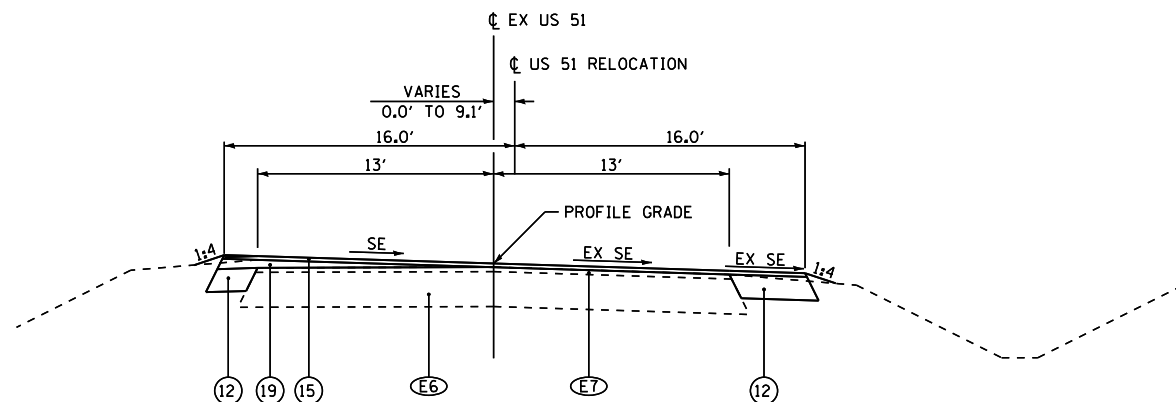

US 51 RELOCATION TYPICAL SECTION

STA 98+50.00 TO STA 100+51.00 SE TRANSITION
 STA 100+51.00 TO STA 102+40.00 SE = 4.4%
 STA 108+50.00 TO STA 110+45.00 SE TRANSITION

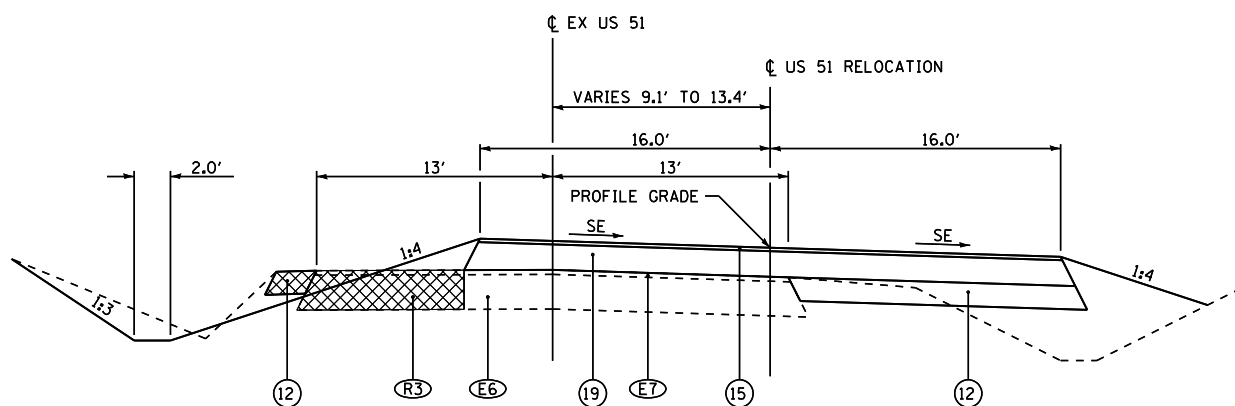

US 51 RELOCATION TYPICAL SECTION

STA 102+40.00 TO STA 104+56.40 SE = 4.4%
 STA 106+57.90 TO STA 108+44.00 SE = 4.4%
 STA 108+44.00 TO STA 108+50.00 SE TRANSITION

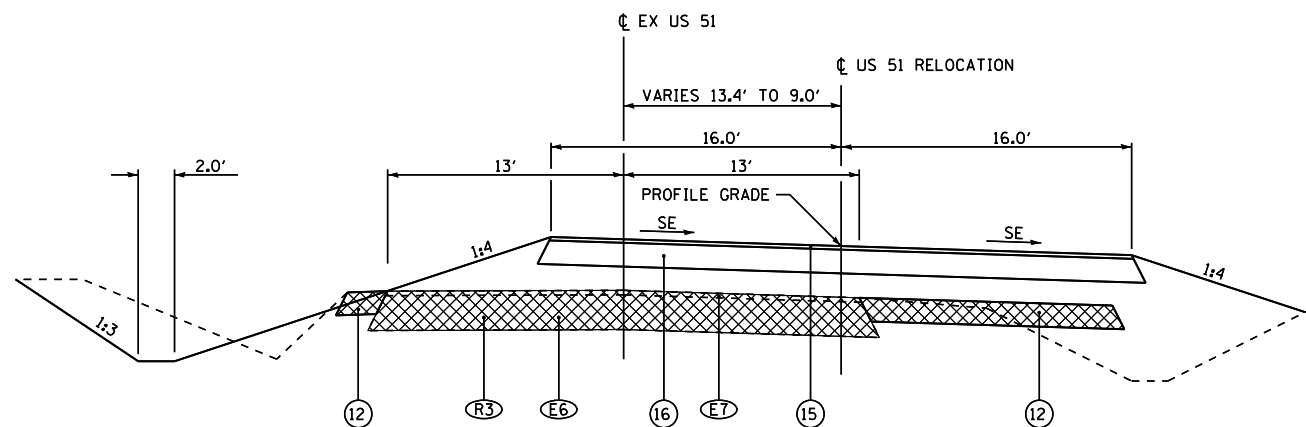

US 51 RELOCATION TYPICAL SECTION

STA 104+56.40 TO STA 106+57.90 SE = 4.4%

- LEGEND**
- (E1) EXISTING GROUND
 - (E2) EXISTING 9"-6"-9" PCC CONCRETE PAVEMENT
 - (E3) EXISTING PCC BASE COURSE, 8"
 - (E4) EXISTING PCC BASE COURSE WIDENING, 9"
 - (E5) EXISTING HOT-MIX ASPHALT BASE COURSE, 10"
 - (E6) EXISTING HOT-MIX ASPHALT BINDER COURSE, 14 1/2"
 - (E7) EXISTING HOT-MIX ASPHALT SURFACING, 1 1/2"
 - (E8) EXISTING HOT-MIX ASPHALT SURFACING, 3"
 - (E9) EXISTING HOT-MIX ASPHALT SURFACING, 3" - 6"
 - (E10) EXISTING HOT-MIX ASPHALT SURFACING, VAR
 - (E11) EXISTING HOT-MIX ASPHALT SHOULDERS, 6"
 - (E12) EXISTING HOT-MIX ASPHALT SHOULDERS, 8"
 - (E13) EXISTING SUB-BASE GRANULAR MATERIAL, 4"
 - (E14) EXISTING LIME MODIFIED SOIL, 12"
 - (E15) EXISTING AGGREGATE SHOULDER, VAR
 - (E16) EXISTING EARTH FILL
 - (E17) EXISTING PIPE UNDERDRAIN
 - (E18) EXISTING FD HOT-MIX ASPHALT PAVEMENT, 13 3/4"
 - (R1) REMOVE EXISTING HMA SHOULDERS
 - (R2) REMOVE EXISTING HMA PAVEMENT, 13 3/4" AND HMA SHOULDERS, 8"
 - (R3) REMOVE EXISTING PAVEMENT, SHOULDERS, AND WIDENING
 - (1) HOT-MIX ASPHALT PAVEMENT (FULL-DEPTH), 13 3/4"
[SEE MIXTURE REQUIREMENTS AND PAVING LIFT DIAGRAMS ON SHEET 3 FOR THE PAVEMENT COMPOSITION]
 - (2) HOT-MIX ASPHALT PAVEMENT (FULL-DEPTH), 9 1/4"
[SEE MIXTURE REQUIREMENTS AND PAVING LIFT DIAGRAMS ON SHEET 3 FOR THE PAVEMENT COMPOSITION]
 - (3a) HOT-MIX ASPHALT SHOULDERS 8"
 - (3) HOT-MIX ASPHALT SHOULDERS 8" (WITH RUMBLE STRIPS, STD 642001)
 - (4) AGGREGATE SHOULDERS, TYPE B
 - (5) SUB-BASE GRANULAR MATERIAL, TYPE C
 - (6) PROCESSING MODIFIED SOIL 12" (LIME)
 - (7) TOPSOIL, 4"
 - (8) PIPE UNDERDRAINS, 4" (STD 601001)
 - (9) AGGREGATE BASE COURSE, TYPE A, 10"
 - (10) BITUMINOUS SURFACE TREATMENT CLASS A-3
 - (11) POLYMERIZED HOT-MIX ASPHALT SURFACE COURSE, MIX "D", N70, 2"
 - (12) HOT-MIX ASPHALT BASE COURSE, 10" (ANY WIDTH)
 - (13) HOT-MIX ASPHALT BASE COURSE, 9 1/2" (ANY WIDTH)
 - (14) HOT-MIX ASPHALT SURFACE REMOVAL, 2"
 - (15) HOT-MIX ASPHALT SURFACE COURSE, MIX "C", N70, 2"
 - (16) HOT-MIX ASPHALT BASE COURSE, 8 1/2" (ANY WIDTH)
 - (17) SUBBASE GRANULAR MATERIAL, TYPE A 8"
 - (18) POLYMERIZED HOT-MIX ASPHALT SURFACE COURSE, MIX "C", N70, 2 1/4"
 - (19) LEVELING BINDER (MACHINE METHOD), N70, VARIABLE DEPTH (2 1/4" MAX)
 - (19) HOT-MIX ASPHALT BINDER COURSE, IL-19.0, N70, VARIABLE DEPTH (2 1/4" MIN)
 - (20) SUBBASE GRANULAR MATERIAL, TYPE A 12"
 - (A) SHOULDER SLOPE - HIGH SIDE OF SE: WHEN THE SE RATE OF THE PAVEMENT IS BETWEEN 0 AND 4% THE SHOULDER SHALL BE SLOPED AT 4%. WHEN THE SE RATE OF THE PAVEMENT EXCEEDS 4% THE SHOULDER SHALL BE SLOPED SO THAT THE ALGEBRAIC DIFFERENCE BETWEEN THE PAVEMENT AND SHOULDER SHALL BE 8%.
 - (B) SHOULDER SLOPE - LOW SIDE OF SE: SLOPE SHALL BE THE SAME AS THE SE BUT NOT LESS THAN 4%.
 - (C) TURN LANE SLOPE - HIGH SIDE OF SE: WHEN THE SE RATE OF THE PAVEMENT IS BETWEEN 0 AND 2% THE TURN LANE SHALL BE SLOPED AT 2%. WHEN THE SE RATE OF THE PAVEMENT EXCEEDS 2% THE TURN LANE SHALL BE SLOPED SO THAT THE ALGEBRAIC DIFFERENCE BETWEEN THE PAVEMENT AND TURN LANE SHALL BE 4%.
 - (D) TURN LANE SLOPE - LOW SIDE OF SE: SLOPE SHALL BE THE SAME AS THE SE BUT NOT LESS THAN 2%.

NOT TO SCALE

REVISIONS	
NAME	DATE

ILLINOIS DEPARTMENT OF TRANSPORTATION
 TYPICAL SECTIONS
 SHEET 10 OF 12
 FAP 322 (US 51)
 SECTION 11-13
 CHRISTIAN COUNTY

SCALE: NONE
 DATE: 7/31/12

DRAWN BY: SEB
 CHECKED BY:

D:\01files\010321\01 SOUTH PLANS NEW\ROAD SHEETS\06\2961\sh-typical sections.dgn 10/5/2012