

STATE OF ILLINOIS
DEPARTMENT OF TRANSPORTATION

DIVISION OF HIGHWAYS

PLANS FOR PROPOSED
FEDERAL AID HIGHWAY

RTE	SECTION	COUNTY	TOTAL SHEETS	SHEET NO.
VARIOUS	2005-027 GRR	VARIOUS	19	1

CONTRACT 62961
D-91-214-05

FOR INDEX OF SHEETS, SEE SHEET NO. 2

ROUTE: VARIOUS EXPRESSWAYS AND ARTERIAL
HIGHWAYS - NORTHERN PART, DISTRICT ONE

GUARDRAIL REPAIR

SECTION: 2005-027 GRR

COUNTY: VARIOUS DISTRICT WIDE

C-91-214-05

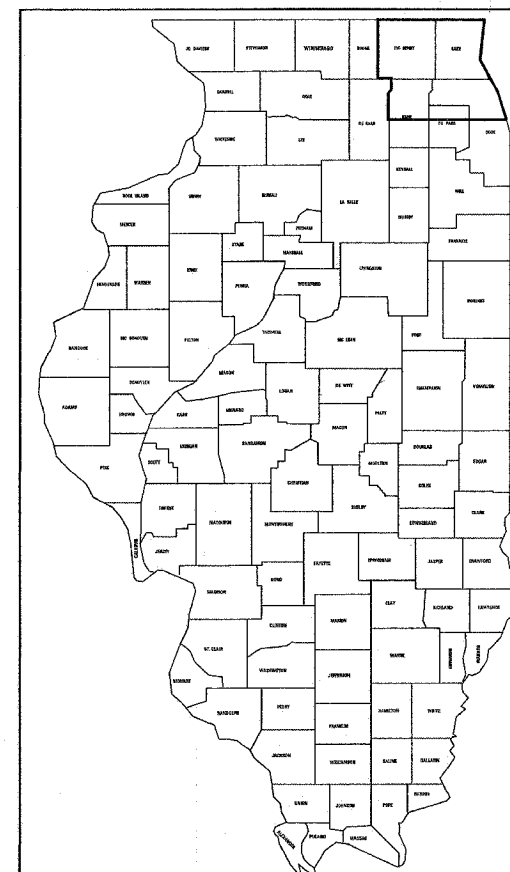

THIS SECTION IS LOCATED ALONG VARIOUS ROUTES WITHIN McHENRY, LAKE, COOK, DU PAGE AND KANE COUNTIES.

SEE LOCATION MAPS
SHEETS 4 THRU 8

STATE OF ILLINOIS
DEPARTMENT OF TRANSPORTATION
DIVISION OF HIGHWAYS

SUBMITTED Sept 11 2006 Diane O'Keefe/col
DEPUTY CHIEF OF HIGHWAY DESIGN ENGINEER

October 13 2006 Mike Dine/KO
ENGINEER OF DESIGN AND ENVIRONMENT

October 13 2006 Milton R. Suen, P.E./KO
DIRECTOR OF HIGHWAY/CHIEF ENGINEER

PRINTED BY THE AUTHORITY
OF THE STATE OF ILLINOIS

CONTRACT NO. 62961

REGION ONE - BUREAU OF DESIGN
PLAN PREPARATION ENGINEER: K. ENG/R. BORO (847) 705-4178

F. A. ETL	SECTION	COUNTY	TOTAL SHEETS	SHEET NO
VAR. 2005-027 GRR	*		19	2
STA.	TO STA.			
FED. ROAD DIST. NO.	LENGTH	FED. AID PROJECT		

* MCHENRY, LAKE, KANE, COOK AND DUPAGE
CONTRACT 62961

INDEX OF SHEETS

1. TITLE SHEET
2. INDEX OF SHEETS
LIST OF APPLICABLE STATE STANDARDS
GENERAL NOTES
3. SUMMARY OF QUANTITIES AND GENERAL NOTES
4. MCHENRY COUNTY LOCATION MAP
5. LAKE COUNTY LOCATION MAP
6. KANE COUNTY LOCATION MAP
7. DU PAGE COUNTY LOCATION MAP
8. COOK COUNTY LOCATION MAP
9. TYPICAL DETAILS FOR STEEL PLATE BEAM
GUARDRAIL ANCHORAGE REPAIR
10. TYPICAL DETAIL FOR GUARDRAIL ANCHOR BLOCK REPAIR
11. TYPICAL DETAIL TO ANCHOR STEEL PLATE BEAM
GUARDRAIL ON CONCRETE
12. DETAIL FOR CENTER LONGITUDINAL GUARDRAIL JOINT
13. DETAIL OF STEEL BEAM GUARDRAIL SPECIAL
14. DETAIL OF GUARDRAIL SUPPORT AND END ANCHORAGE
15. DETAIL OF THRIE-BEAM GUARDRAIL
WITH MODIFIED OFFSET BLOCK
16. STEEL PLATE BEAM GUARDRAIL STEEL BLOCK-OUT DETAIL
17. CURB REMOVAL (PARTIAL) AND SHOULDER WIDENING FOR
TRAFFIC BARRIER TERMINAL, TYPE 1 SPECIAL
18. STEEL BRIDGE RAIL DETAIL
19. TRAFFIC CONTROL DETAIL FOR SHOULDER CLOSURE AND PARTIAL RAMP CLOSURES

STATE STANDARDS

630001-07 701006-02 701411-03
630301-04 701011-01 701501-03
631006-03 701101-01 701606-04
631011-03 701201-02 701701-04
631026-03 701301-02 701801-03
631031-06 701400-02 702001-06
631036-04 701401-03 720011
635006-02 701406-04 BLR-23-1
635011-01

GENERAL NOTES

ALL WORK IS TO BE REPLACED IN KIND OR AS INDICATED ON THE CONTRACT QUANTITY SHEET.

GUARDRAIL WORK WILL INCLUDE ALIGNMENT AS NECESSARY TO RESTORE THE RAIL TO THE ORIGINAL CONDITIONS.

REMOVAL OF DAMAGED MATERIALS WILL INCLUDE DISMANTLING, LOADING, HAULING AND DISPOSAL. THE WORK SITE WILL BE LEFT IN A SAFE AND ORDERLY CONDITION.

NO MATERIAL SHOULD BE LEFT ON OR NEAR THE ROADWAY DURING NON-WORKING HOURS.

ANY NECESSARY TRAFFIC CONTROL WILL BE PROVIDED BY THE CONTRACTOR; APPROPRIATE STANDARDS ARE HEREWITH ATTACHED (SEE COVER SHEET).

THE LIMITS OF THE DAMAGED GUARDRAIL WILL BE MARKED WITH PAINT. THE REPLACEMENT PARTS AND THE QUANTITIES INDICATED ARE WITHIN THESE LIMITS AS MARKED.

REMOVED GUARDRAIL THAT IS NOT REPLACED ON THE SAME DAY MUST BE DELINEATED WITH LIGHTED BARRICADES. NO LOCATIONS WILL BE LEFT WITHOUT EITHER LIGHTED BARRICADES OR RESTORED GUARDRAIL AT ANY TIME.

GUARDRAIL MARKERS SHALL NOT BE ATTACHED TO TERMINAL SECTIONS.

REVISIONS	
NAME	DATE
CREATED	10-31-88

ILLINOIS DEPARTMENT OF TRANSPORTATION

**INDEX OF SHEETS, PLAN SHEETS
AND STATE STANDARDS**

SCALE: NONE
DATE: 10-31-88

DRAWN BY R.F.L.
CHECKED BY

SUMMARY OF QUANTITIES

URBAN
SFTY - 3J
100% STATE

FILE NO.	SECTION	COUNTY	TOTAL SHEETS	SHEET NO.
VAR 2005-027	GRR *	*	19	3
STA.	TO STA.			
FED. ROAD DIST. NO.	ILLINOIS	FED. AID PROJECT		

*MCHENRY, LAKE, KANE, COOK AND DUPAGE
CONTRACT 62961

CODE NO.	ITEM	UNIT	TOTAL QUANTITY	CONTRACT MAINTENANCE	100% MchD
X0301763	FURNISHING AND INSTALLING TRAFFIC BARRIER TERMINAL, TYPE 1B	EACH	2	1	1
63001105	FURNISHING AND INSTALLING GUARDRAIL BLOCKS	EACH	620	530	90
63001205	FURNISHING AND INSTALLING GUARDRAIL CHANNEL	EACH	19	16	3
63001305	FURNISHING AND INSTALLING RAIL ELEMENT PLATES	EACH	725	630	95
63300800	GUARDRAIL POST VERTICAL ADJUSTMENT	EACH	25	21	4
50901001	STEEL BRIDGE RAIL	FOOT	150	125	25
78201000	TERMINAL MARKERS-DIRECT APPLIED	EACH	6	5	1
78200405	GUARDRAIL MARKERS	EACH	285	245	40
Z0025200	FURNISHING AND INSTALLING CONNECTING END SECTION	EACH	3	2	1
Z0025600	FURNISHING AND INSTALLING RETURN END SECTION	EACH	5	4	1
Z0025800	FURNISHING AND INSTALLING SINGLE END SECTION	EACH	4	3	1
Z0026200	FURNISHING AND INSTALLING TRAFFIC BARRIER TERMINAL TYPE 2	EACH	5	4	1
Z0026700	FURNISHING AND SETTING STEEL POSTS	EACH	500	435	65
Z0026800	FURNISHING AND SETTING STEEL POSTS (MODIFIED)	EACH	10	8	2
Z0026900	FURNISHING AND SETTING STEEL POSTS (SPECIAL)	EACH	9	7	2
Z0051400	REMOVING AND RESETTNG POSTS	EACH	125	110	15
Z0052100	REPAIR STEEL PLATE BEAM GUARD RAIL, TYPE B	FOOT	100	87.5	12.5
Z0052200	REPAIR STEEL PLATE BEAM GUARD RAIL, TYPE C	FOOT	25	12.5	12.5
Z0052550	REPAIR TRAFFIC BARRIER TERMINAL, TYPE 1B	EACH	2	1	1
Z0052600	REPAIR TRAFFIC BARRIER TERMINAL TYPE 2	EACH	17	15	2
Z0052900	REPAIR TRAFFIC BARRIER TERMINAL TYPE 4	EACH	3	2	1
Z0053000	REPAIR TRAFFIC BARRIER TERMINAL TYPE 5	EACH	3	2	1
Z0053200	REPAIR TRAFFIC BARRIER TERMINAL TYPE 6	EACH	4	3	1
Z0053400	REPAIR TRAFFIC BARRIER TERMINAL TYPE 8	EACH	3	2	1
X0300501	FURNISHING AND INSTALLING TRAFFIC BARRIER TERMINAL TYPE 1, NOSE	EACH	15	13	2
XZ190600	FURNISHING AND INSTALLING TRAFFIC BARRIER TERMINAL TYPE 6	EACH	3	2	1
X0321152	FURNISHING AND INSTALLING RADIUS RAIL ELEMENT PLATES	EACH	35	30	5
XZ190500	FURNISHING AND INSTALLING TRAFFIC BARRIER TERMINAL TYPE 5	EACH	2	1	1
X0321562	FURNISHING AND INSTALLING TRAFFIC BARRIER TERMINAL TYPE 3 SPECIAL	EACH	3	2	1
X0321563	REPAIR TRAFFIC BARRIER TERMINAL TYPE 1 SPECIAL	EACH	160	140	20
X0321564	REPAIR TRAFFIC BARRIER TERMINAL TYPE 3 SPECIAL	EACH	4	3	1
X0322240	FURNISHING AND SETTING THRIE-BEAM POSTS	EACH	4	3	1
X0322241	FURNISHING AND INSTALLING THRIE-BEAM RADIUS ELEMENT PLATES	EACH	4	3	1
X0320619	FURNISHING AND INSTALLING THRIE-BEAM GUARDRAIL ELEMENT PLATES	EACH	4	3	1
X0322242	FURNISHING AND INSTALLING THRIE-BEAM MODIFIED BLOCKS	EACH	4	3	1
X0322451	REPAIR TRAFFIC BARRIER TERMINAL TYPE 1 SPECIAL - POST	EACH	175	153	22
X0322452	REPAIR TRAFFIC BARRIER TERMINAL TYPE 1 SPECIAL - RAIL ELEMENT PLATE	EACH	40	35	5
X0322603	FURNISHING AND INSTALLING TRAFFIC BARRIER TERMINAL TYPE 3 SPECIAL, NOSE	EACH	5	4	1
44002300	CURB REMOVAL (PARTIAL)	FOOT	100	100	0
X0301849	FURNISHING AND INSTALLING TRAFFIC BARRIER TERMINAL TYPE 1, SPECIAL (TANGENT)	EACH	30	26	4
X0301850	FURNISHING AND INSTALLING TRAFFIC BARRIER TERMINAL TYPE 1, SPECIAL (FLARED)	EACH	5	4	1
63000000	STEEL PLATE BEAM GUARD RAIL, TYPE A	FOOT	1400	1400	0
63100167	TRAFFIC BARRIER TERMINAL TYPE 1, SPECIAL (TANGENT)	EACH	2	2	0
63100045	TRAFFIC BARRIER TERMINAL TYPE 2	EACH	2	2	0
Z0052400	REPAIR TRAFFIC BARRIER TERMINAL, TYPE 1	EACH	9	7	2

GENERAL NOTES

ALL WORK IS TO BE REPLACED IN KIND OR AS INDICATED ON THE CONTRACT QUANTITY SHEET.

GUARDRAIL WORK WILL INCLUDE ALIGNMENT AS NECESSARY TO RESTORE THE RAIL TO THE ORIGINAL CONDITIONS.

REMOVAL OF DAMAGED MATERIALS WILL INCLUDE DISMANTLING, LOADING, HAULING AND DISPOSAL. THE WORK SITE WILL BE LEFT IN A SAFE AND ORDERLY CONDITION.

NO MATERIAL SHOULD BE LEFT ON OR NEAR THE ROADWAY DURING NON-WORKING HOURS.

ANY NECESSARY TRAFFIC CONTROL WILL BE PROVIDED BY THE CONTRACTOR; APPROPRIATE STANDARDS ARE HEREWITH ATTACHED (SEE COVER SHEET).

THE LIMITS OF THE DAMAGED GUARDRAIL WILL BE MARKED WITH PAINT. THE REPLACEMENT PARTS AND THE QUANTITIES INDICATED ARE WITHIN THESE LIMITS AS MARKED.

REMOVED GUARDRAIL THAT IS NOT REPLACED ON THE SAME DAY MUST BE DELINEATED WITH LIGHTED BARRICADES. NO LOCATIONS WILL BE LEFT WITHOUT EITHER LIGHTED BARRICADES OR RESTORED GUARDRAIL AT ANY TIME.

GUARDRAIL MARKERS SHALL NOT BE ATTACHED TO TERMINAL SECTIONS.

ILLINOIS DEPARTMENT OF TRANSPORTATION

GUARDRAIL REPAIR
SECTION 2003-039 GRR
NORTHERN PART, DISTRICT ONE
SUMMARY OF QUANTITIES SHEET

SCALE: NONE
DATE 10/3/2006





DRAWN BY
CHECKED BY

K.A. DIV.	SECTION	COUNTY	TOTAL SHEETS	SHEET NO.
VAR.2005-027 GRR *			17	4
STA.	TO STA.			
FED. ROAD DIST. NO.	ILLINOIS	FED. AID PROJECT		

*MCHENRY, LAKE, KANE, COOK AND DUPAGE
CONTRACT 62961



DISTRICT NO. 1

-  STATE HIGHWAYS & EXPRESSWAYS WITHIN STATE JURISDICTION. (EXCEPT TOLLWAYS)
-  CITY MAINTENANCE AGREEMENTS UNDER STATE JURISDICTION
-  FUTURE HIGHWAYS
-  VARIOUS AGENCIES HIGHWAYS

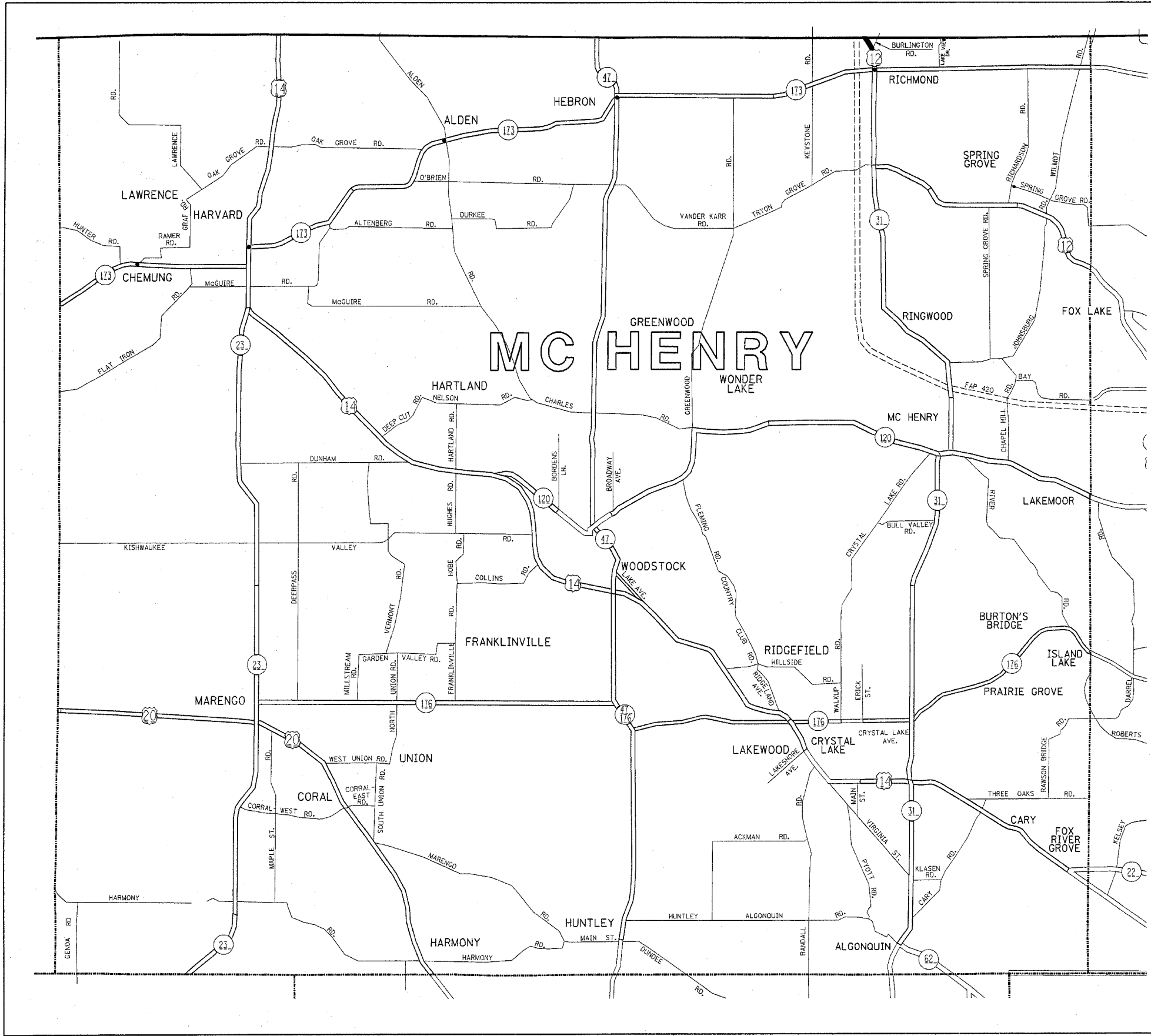

REVISIONS	
NAME	DATE

ILLINOIS DEPARTMENT OF TRANSPORTATION
 NORTHERN PART, DISTRICT 1

**GUADRIL REPAIR
 LOCATION MAP
 MC HENRY COUNTY**

SCALE: 1"=1.5 MILES
 DATE: 10/2/2006

DRAWN BY CADD
 CHECKED BY

K.A. NO.	SECTION	COUNTY	TOTAL SHEETS	SHEET NO.
VAR-2005-027 GRR	*	19	5	
STA.	TO STA.			
FED. ROAD DIST. NO.	ILLINOIS	FED. AID PROJECT		

* MCHENRY, LAKE, KANE, COOK AND DUPAGE
CONTRACT 62961

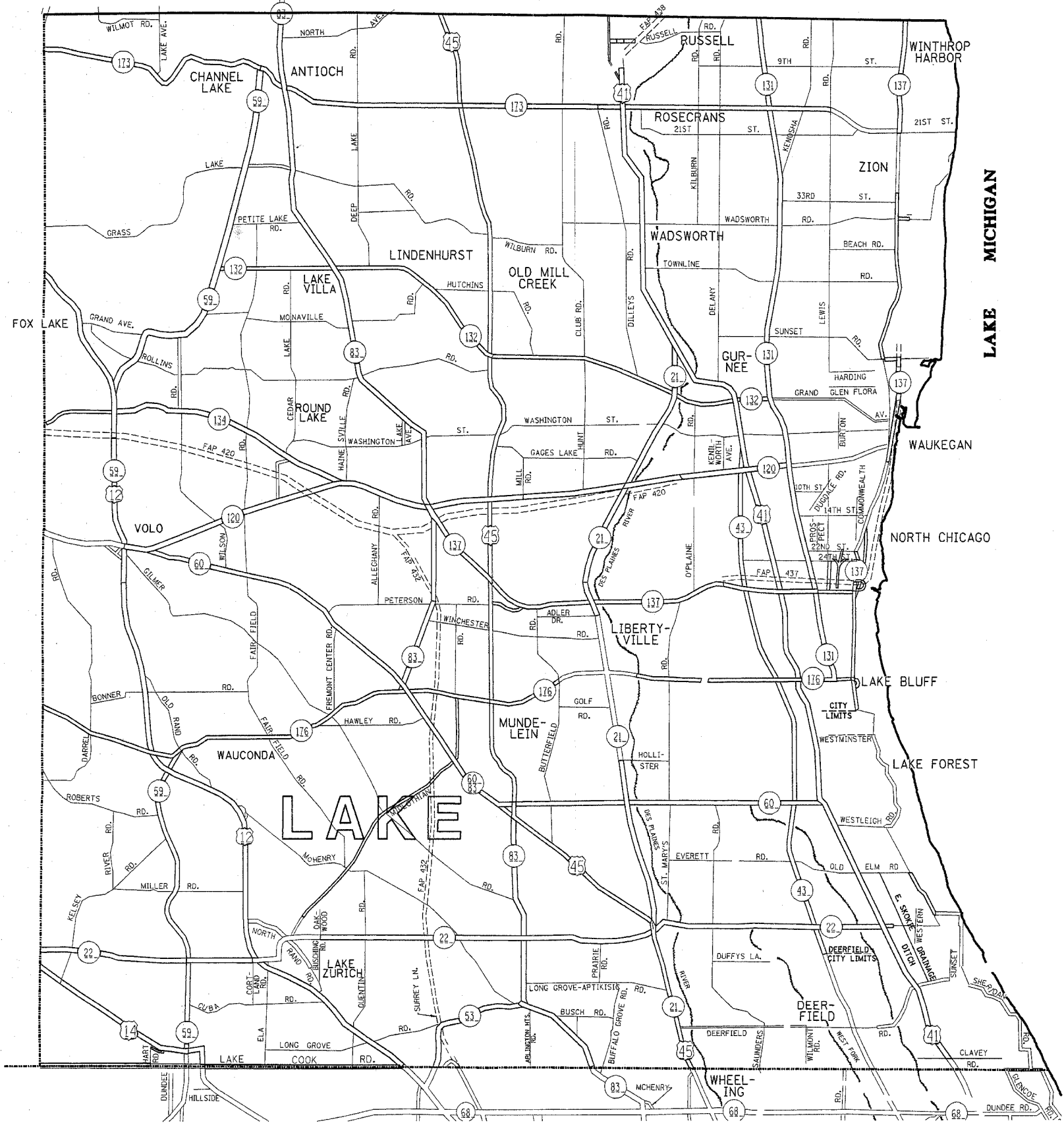

DISTRICT NO. 1

- STATE HIGHWAYS & EXPRESSWAYS WITHIN STATE JURISDICTION. (EXCEPT TOLLWAYS)
- CITY MAINTENANCE AGREEMENTS UNDER STATE JURISDICTION
- FUTURE HIGHWAYS
- VARIOUS AGENCIES HIGHWAYS

REVISIONS	
NAME	DATE

ILLINOIS DEPARTMENT OF TRANSPORTATION
NORTHERN PART, DISTRICT 1

**GUARDRAIL REPAIR
LOCATION MAP
LAKE COUNTY**

SCALE: 1"=1.5 MILES
DATE: 10/2/2006

DRAWN BY
CHECKED BY

10/2/2006
c:\p\project\m06188\m06188bb.mxd

F.A. DIST.	SECTION	COUNTY	TOTAL SHEETS	SHEET NO.
VAR.2005-027	GRR	*	19	6
STA.	TO STA.			
FED. AID DIST. NO.	BLMDS	FED. AID PROJECT		

* MCHENRY, LAKE, KANE, COOK AND DUPAGE
CONTRACT 62961

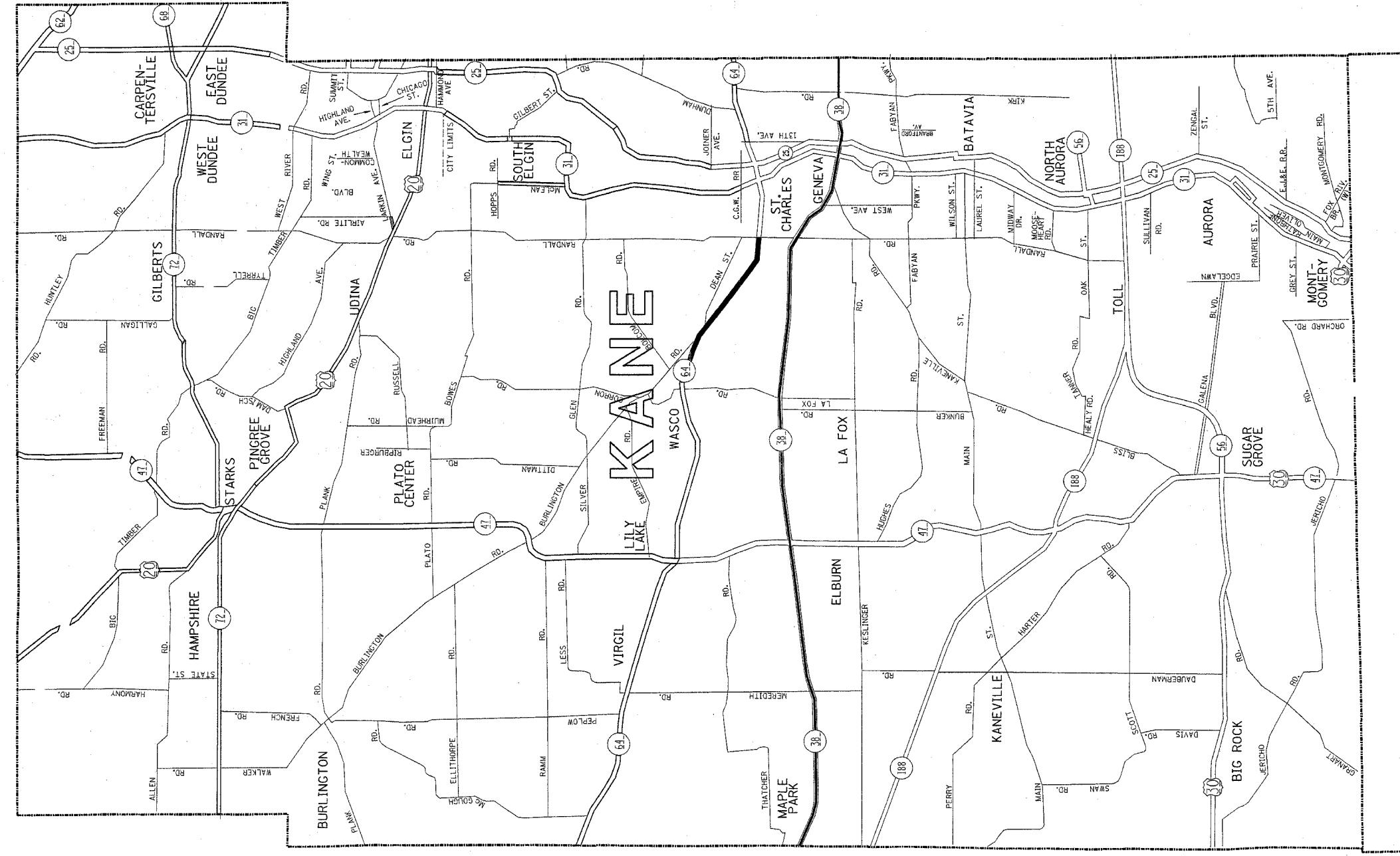

DISTRICT NO. 1

- STATE HIGHWAYS & EXPRESSWAYS WITHIN STATE JURISDICTION. (EXCEPT TOLLWAYS)
- CITY MAINTENANCE AGREEMENTS UNDER STATE JURISDICTION
- FUTURE HIGHWAYS
- VARIOUS AGENCIES HIGHWAYS

ILLINOIS DEPARTMENT OF TRANSPORTATION
 NORTHERN PART, DISTRICT 1
 GUARDRAIL REPAIR
 LOCATION MAP
 KANE COUNTY
 NORTH OF AND INCLUDING IL. ROUTE 38

REVISIONS	
NAME	DATE



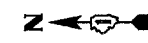
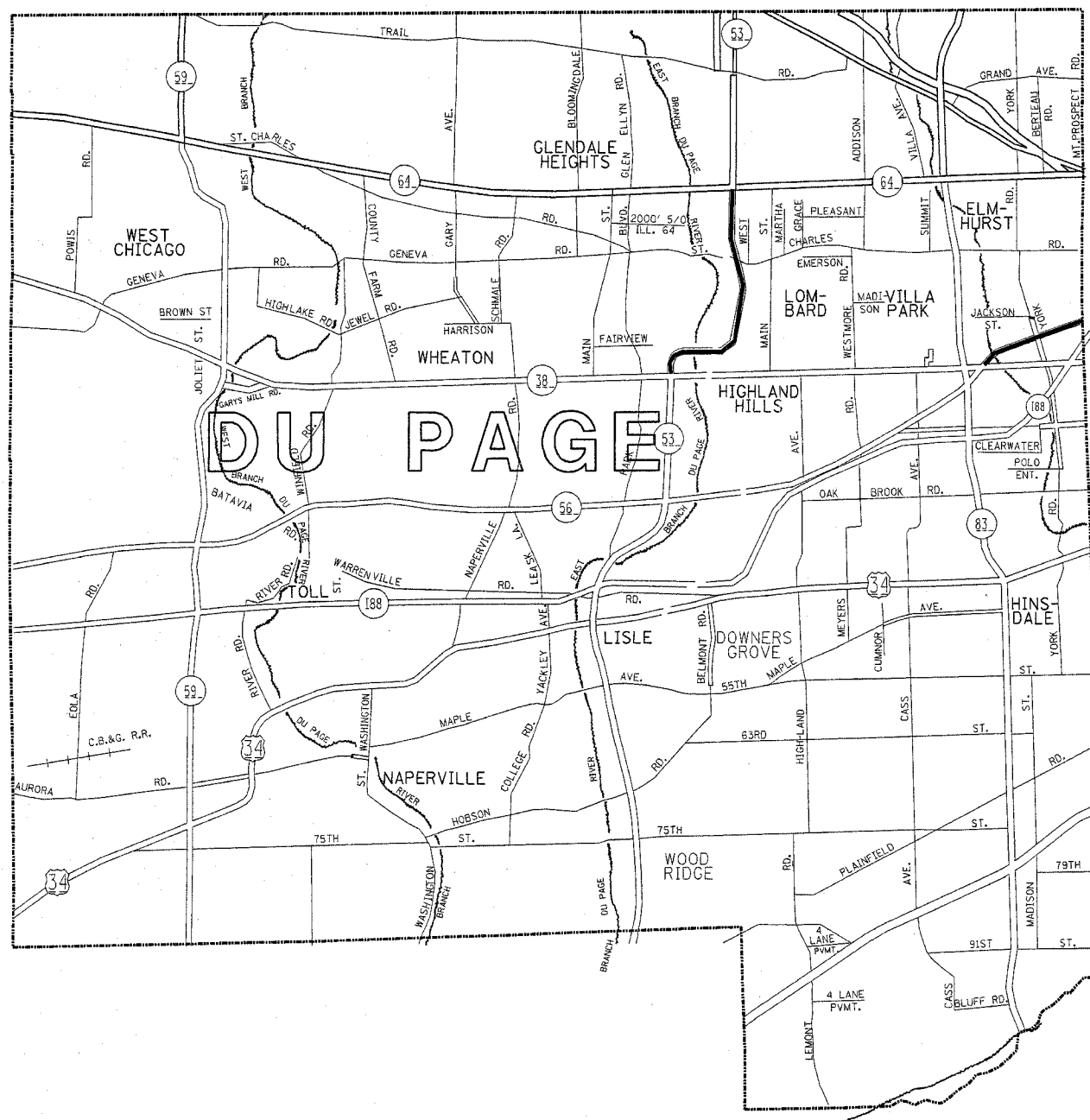

SCALE: 1"=1.5 MILES
 DATE: 10/2/2006
 DRAWN BY
 CHECKED BY

F. A. NO.	SECTION	COUNTY	TOTAL SHEETS	SHEET NO.
VAR.2005-027 GRR	*		19	7
STA.	TO STA.			
FED. ROAD DIST. NO.	ILLINOIS	FED. AID PROJECT		

* McHENRY, LAKE, KANE, COOK AND DUPAGE
CONTRACT 62961



DISTRICT NO. 1

-  CITY MAINTENANCE AGREEMENTS UNDER STATE JURISDICTION
-  FUTURE HIGHWAYS
-  VARIOUS AGENCIES HIGHWAYS
-  STATE HIGHWAYS & EXPRESSWAYS WITHIN STATE JURISDICTION. (EXCEPT TOLLWAYS)

ILLINOIS DEPARTMENT OF TRANSPORTATION
NORTHERN PART, DISTRICT 1

GUARDRAIL REPAIR
DU PAGE COUNTY
SOUTH OF IL. ROUTE 38

REVISIONS	
NAME	DATE

SCALE: 1"=1.5 MILES
DATE: 10/2/2006
DRAWN BY
CHECKED BY

P.A. NO.	SECTION	COUNTY	TOTAL SHEETS	SHEET NO.
VAR.2005-027 GRR *		COOK *	19	8
STA.	TO STA.			
FED. ROAD DIST. NO.	ILLINOIS	FED. AID PROJECT		

* MCHENRY, LAKE, KANE, COOK AND DUPAGE
CONTRACT 62961

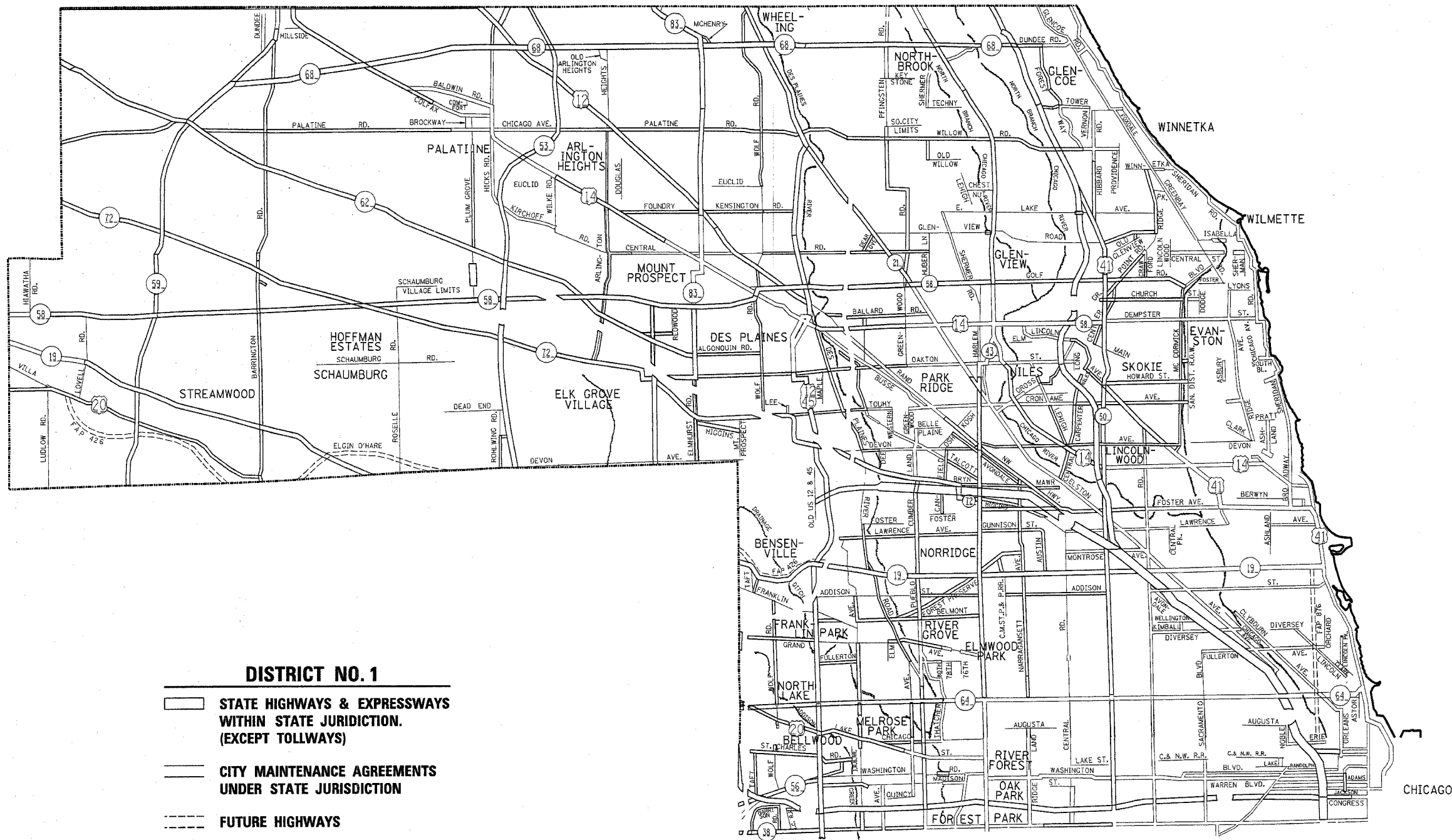

DISTRICT NO. 1

- STATE HIGHWAYS & EXPRESSWAYS
WITHIN STATE JURISDICTION.
(EXCEPT TOLLWAYS)
- CITY MAINTENANCE AGREEMENTS
UNDER STATE JURISDICTION
- FUTURE HIGHWAYS
- VARIOUS AGENCIES HIGHWAYS

REVISIONS	
NAME	DATE

ILLINOIS DEPARTMENT OF TRANSPORTATION
NORTHERN PART, DISTRICT 1

GUARDRAIL REPAIR LOCATION MAP
COOK COUNTY
NORTH OF AND INCLUDING
IL. ROUTE 38

SCALE: 1"=3 MILES
DATE: 10/2/2006

DRAWN BY
CHECKED BY

P.A. DIST.	SECTION	COUNTY	TOTAL SHEETS	SHEET NO.
VAR. 2005-027 GRR	*		19	9
STA.	TO STA.			
FED. ROAD DIST. NO.	SUBNO.	FED. AID PROJECT		

* McHENRY, LAKE, KANE, COOK AND DUPAGE
CONTRACT 62961

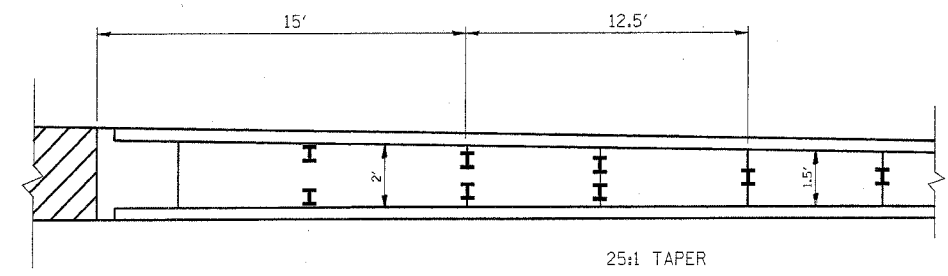
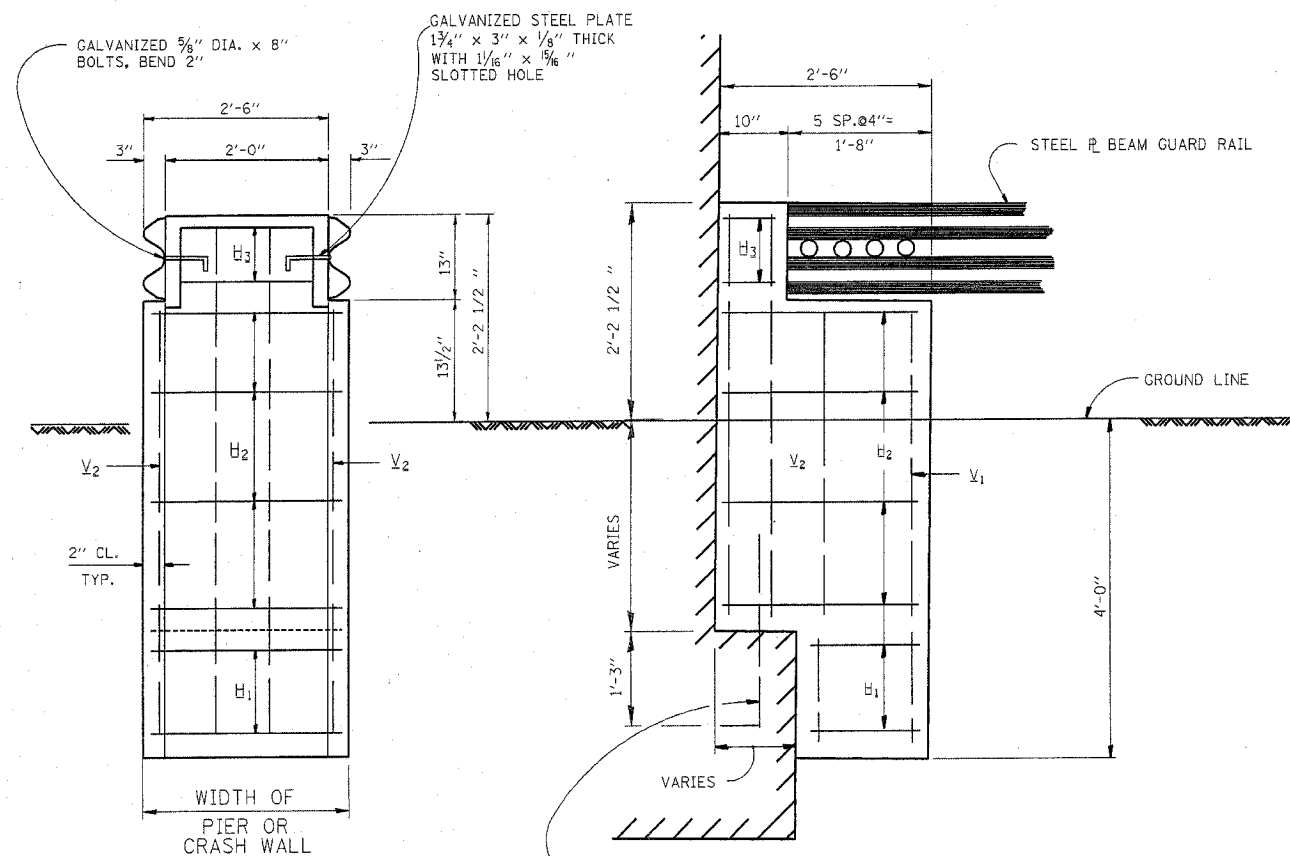

GUARD RAIL TRANSITIONS

NOTES: CLASS SI CONCRETE SHALL BE USED THROUGHOUT
REINFORCEMENT TO BE SIZE #4 UNLESS OTHERWISE NOTED

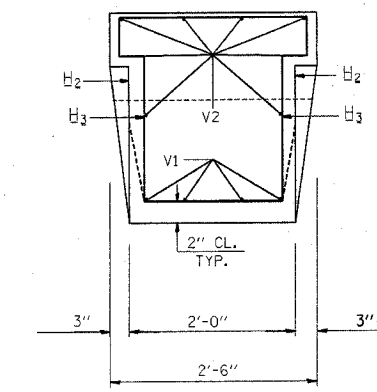

#6 DOWEL BARS
DRILL AND GROUT ON ROW OF THREE BARS

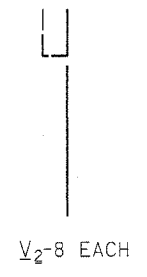
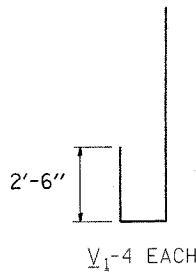
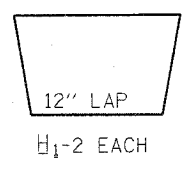
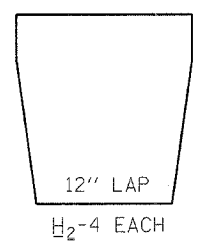
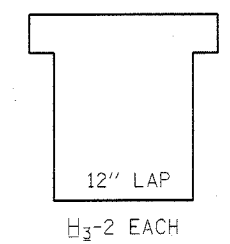

ILLINOIS DEPARTMENT OF TRANSPORTATION

**TYPICAL DETAILS FOR
STEEL PLATE BEAM GUARDRAIL
ANCHORAGE REPAIR**

SCALE: NONE
DATE: 10/2/2006

DRAWN BY: R.F.L.
CHECKED BY:

REVISIONS	
NAME	DATE
CREATED	10-31-88

F.L. NO.	SECTION	COUNTY	TOTAL SHEETS	SHEET NO.
VAR. 2005-027 GRR	*	19	10	
STA.	TO STA.			
FED. ROAD DIST. NO.	ILLINOIS	FED. AID PROJECT		

* MCHENRY, LAKE, KANE, COOK AND DUPAGE
CONTRACT 62961

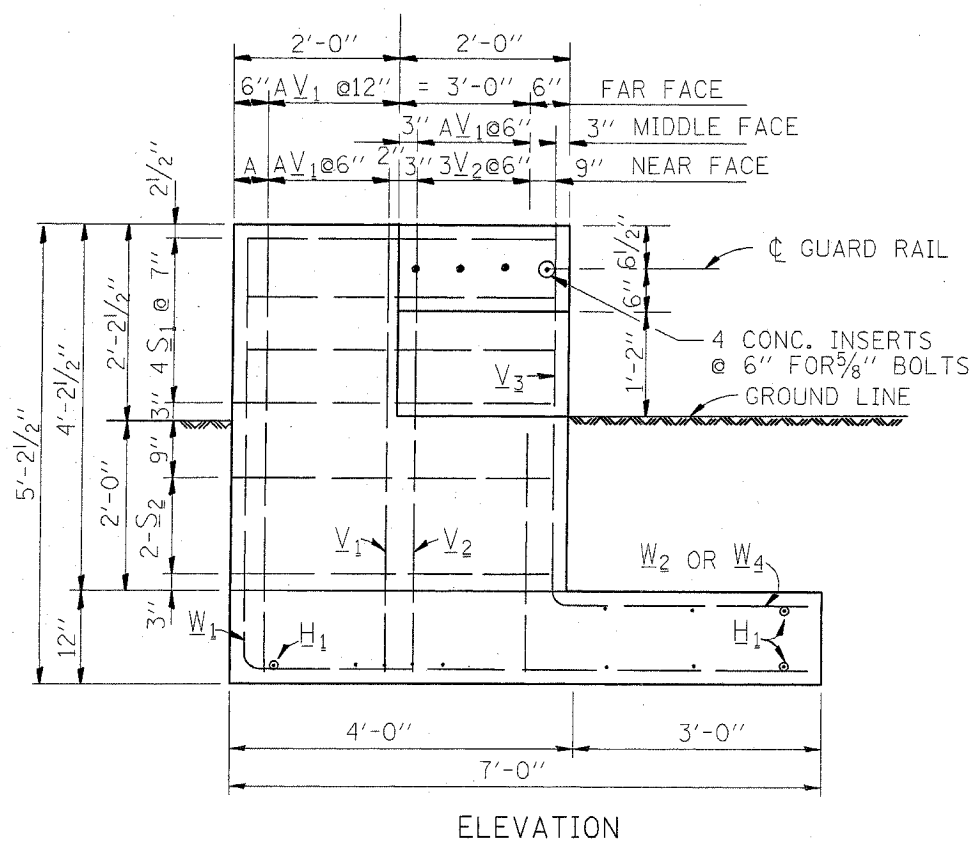

ELEVATION

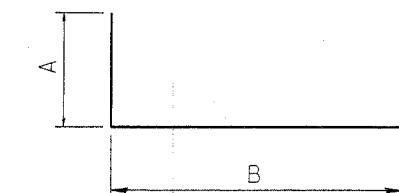

BAR	A	B	A+B
V ₁	4'-8"	6"	5'-2"
V ₂	2'-6"	6"	3'-0"
W ₁	4'-8"	6'-6"	11'-2"
W ₂	2'-0"	3'-0"	5'-0"
W ₄	4'-2"	3'-0"	7'-2"

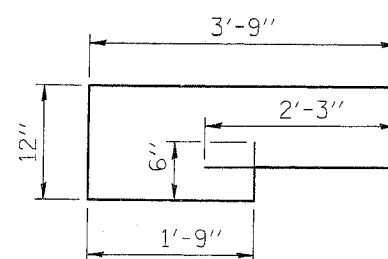

S₁ BAR

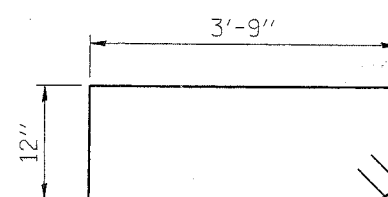

S₂ BAR

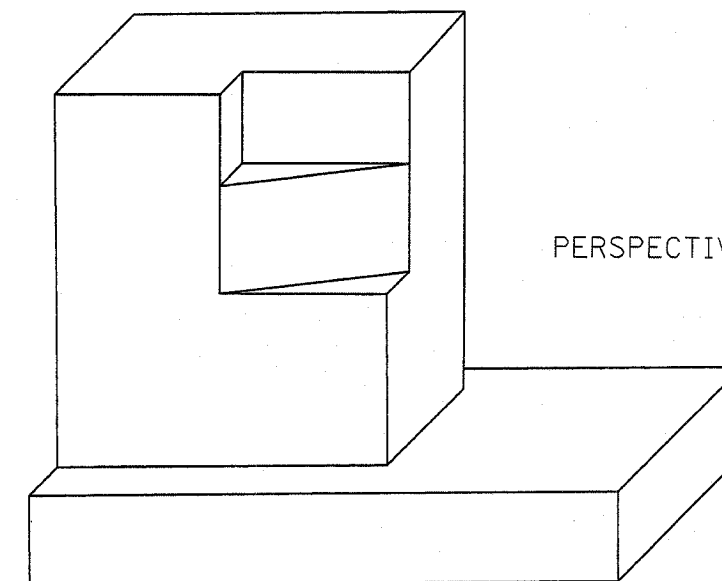

PERSPECTIVE VIEW

NOTES: CLASS SI CONCRETE SHALL BE USED THROUGHOUT
REINFORCEMENT TO BE SIZE #4 UNLESS OTHERWISE NOTED

BAR SCHEDULE

BAR	NO.	LENGTH
V ₁	8	5'-2"
V ₂	3	3'-0"
V ₃	4	3'-0"
W ₁	3	11'-2"
W ₂	1	5'-0"
W ₃	2	6'-6"
W ₄	2	7'-2"
S ₁	4	10'-0"
S ₂	2	10'-0"
H ₁	1	2'-3"

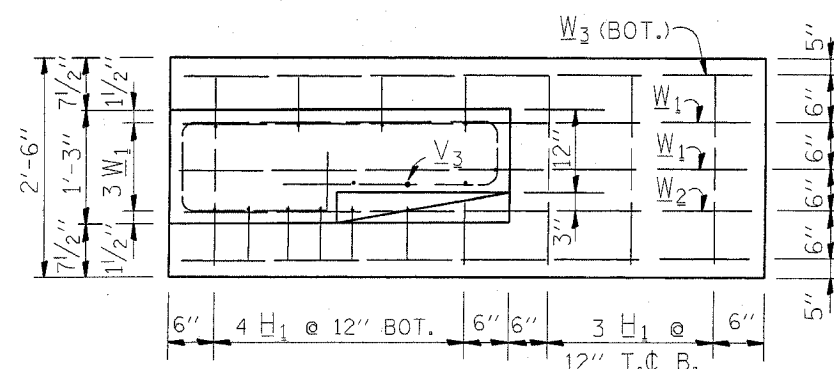

FOOTING PLAN

THIS SHEET IS FOR INFORMATION ONLY

REVISIONS	
NAME	DATE
CREATED	10-31-88

ILLINOIS DEPARTMENT OF TRANSPORTATION

TYPICAL DETAIL FOR
GUARDRAIL ANCHOR BLOCK
REPAIR

SCALE: NONE
DATE: 10/2/2006

DRAWN BY R.F.L.
CHECKED BY

F. A. DIST.	SECTION	COUNTY	TOTAL SHEETS	SHEET NO.
VAR. 2003-039 GRR	*	17	11	
STA.	TO STA.			
FED. ROAD DIST. NO.	ILLINOIS	FED. AID PROJECT		

* WILL, KENDAL, KANE, DU PAGE AND COOK
CONTRACT 62601

NOTE:
 FOR DETAILS OF RAIL ELEMENTS, RAIL SPLICING, NUT, BOLT AND SIDE VIEW OF RAIL, SEE STANDARD 630001

ALL WELDS SHALL BE GROUND SMOOTH

POSTS SHALL BE CUT AND WELDED TO THE BASE PLATE SO THAT THE POST WILL BE PLUMB WHEN ERECTED.

TWO PERCENT (2%) OF ALL ANCHOR BOLTS SHALL BE TEST LOADED IN PLACE, MINIMUM TEST LOAD=8 KIPS. IF ONE ANCHOR BOLT FAILS DURING THE TEST, TWO OTHER ANCHOR BOLTS SHALL BE TESTED. TESTING EQUIPMENT SHALL BE BOLT COMPANIES.

PROVIDE 1/8" AND 2/16" GALVANIZED SHIMS FOR 25% OF THE POSTS.

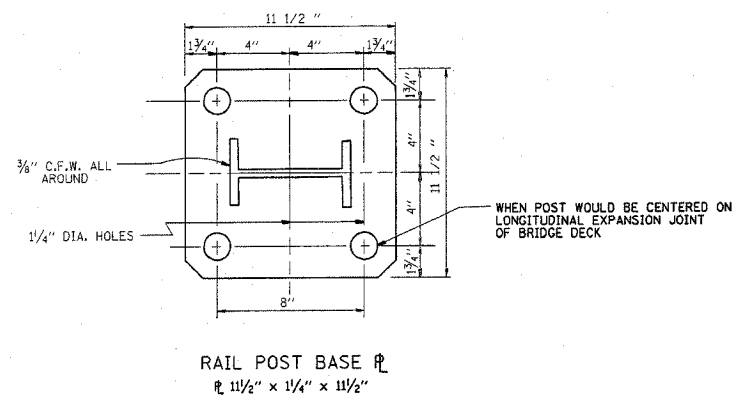

NOTE:
 ALL WELDS SHALL BE GROUND SMOOTH. POSTS SHALL BE CUT AND WELDED TO THE TO THE BASE PLATE SO THAT THE POSTS WILL BE PLUMB WHEN ERECTED.

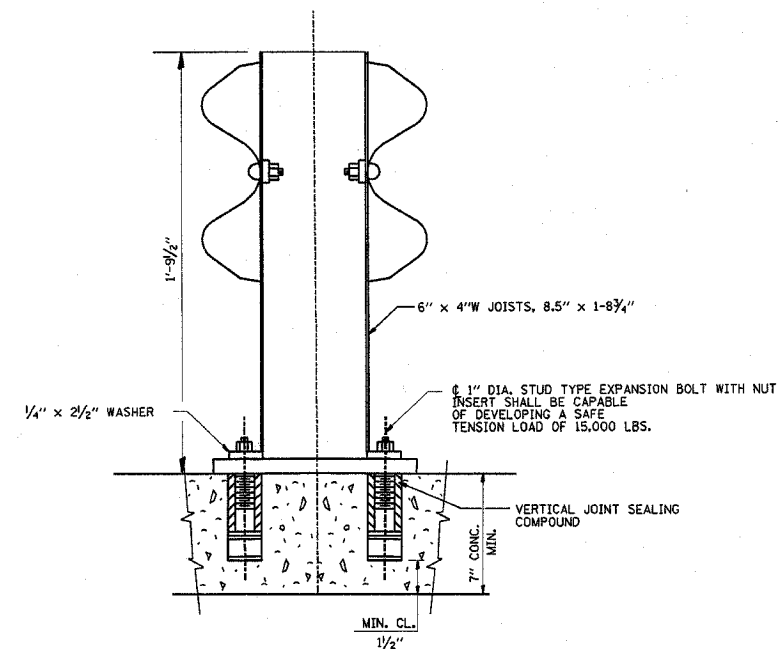

REVISIONS	
NAME	DATE
CREATED	10-31-88

ILLINOIS DEPARTMENT OF TRANSPORTATION

**ANCHOR DETAIL FOR
 STEEL PLATE BEAM GUARD RAIL
 ON CONCRETE**

SCALE: NONE
 DATE: 10-31-88

DRAWN BY R.F.L.
 CHECKED BY

F. A. REV.	SECTION	COUNTY	TOTAL SHEETS	SHEET NO.
	VAR. 2005-027 GRR	*	19	12
STA.	TO STA.			
FED. ROAD DIST. NO.	ILLINOIS	FED. AID PROJECT		

* McHENRY, LAKE, KANE, COOK AND DUPAGE
CONTRACT 62961

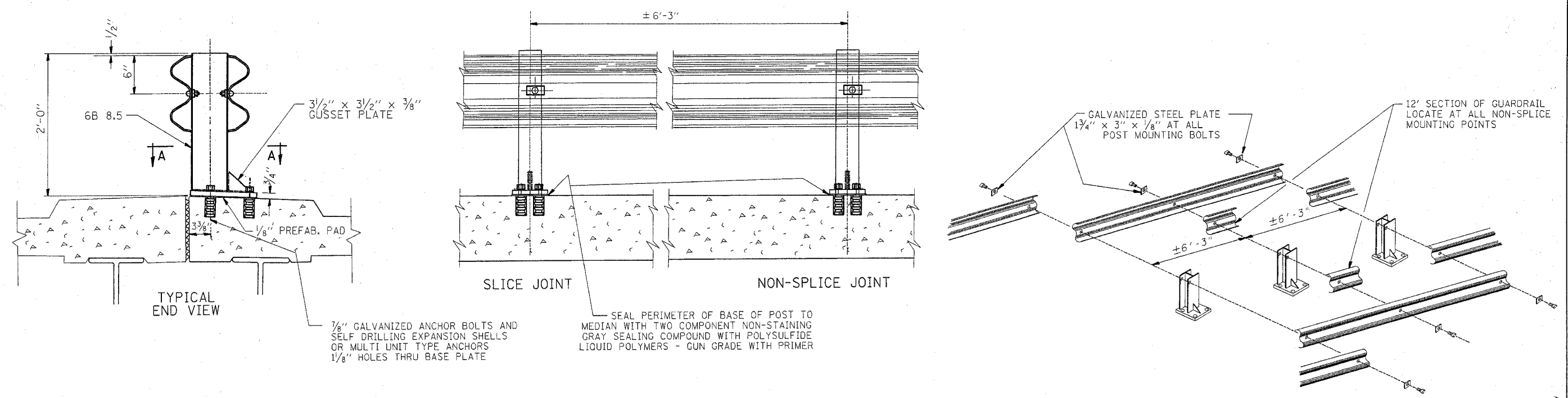

7/8" GALVANIZED ANCHOR BOLTS AND SELF DRILLING EXPANSION SHELLS OR MULTI UNIT TYPE ANCHORS 1/8" HOLES THRU BASE PLATE

SEAL PERIMETER OF BASE OF POST TO MEDIAN WITH TWO COMPONENT NON-STAINING GRAY SEALING COMPOUND WITH POLYSULFIDE LIQUID POLYMERS - GUN GRADE WITH PRIMER

NOTE:
DIAMOND TIPPED DRILL SHALL BE USED TO DRILL THRU REINFORCEMENT BARS

NOTE:
POSTS SHALL BE HOT DIPPED GALVANIZED AFTER FABRICATION IN ACCORDANCE WITH ASTM DESIGNATIONS A-123 AND A-385.
TWO PERCENT (2%) OF ALL ANCHOR BOLTS SHALL BE TEST LOADED IN PLACE. MIN. TEST LOAD = 8 KIPS.
ALL BOLTS, NUTS AND WASHERS SHALL BE GALVANIZED IN ACCORDANCE WITH ASTM DESIGNATION A-153.
FOR MATERIAL COMPOSITION OF PREFABRICATED PAD, SEE ARTICLE 54.9(F), (BEARING AND ANCHORAGE), OF THE STANDARD SPECIFICATIONS.
PROVIDE 1-1/8" AND 2-1/16" GALVANIZED STEEL SHIMS FOR 25% OF THE POSTS.
IF ONE ANCHOR BOLT FAILS DURING TEST, TWO OTHER ANCHOR BOLTS SHALL BE TESTED. TESTING EQUIPMENT CAN BE OBTAINED FROM BOLT COMPANIES.

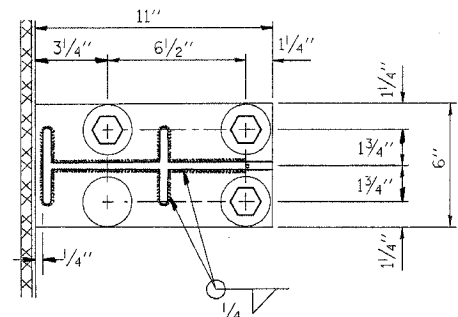

SEC. A-A

THIS SHEET IS FOR INFORMATION ONLY

REVISIONS	
NAME	DATE
CREATED	10-31-88

ILLINOIS DEPARTMENT OF TRANSPORTATION

**TYPICAL DETAIL FOR
CENTER LONGITUDINAL JOINT
GUARDRAIL JOINT**

SCALE: NONE
DATE: 10/2/2006

DRAWN BY R.F.L.
CHECKED BY

P.A. NO.	SECTION	COUNTY	TOTAL SHEETS	SHEET NO.
VAR. 2005-027 GRR	*		19	13
STA.	TO STA.			
FED. ROAD DIST. NO.	ILLINOIS	FED. AID PROJECT		

* MCHENRY, LAKE, KANE, COOK AND DUPAGE
CONTRACT 62961

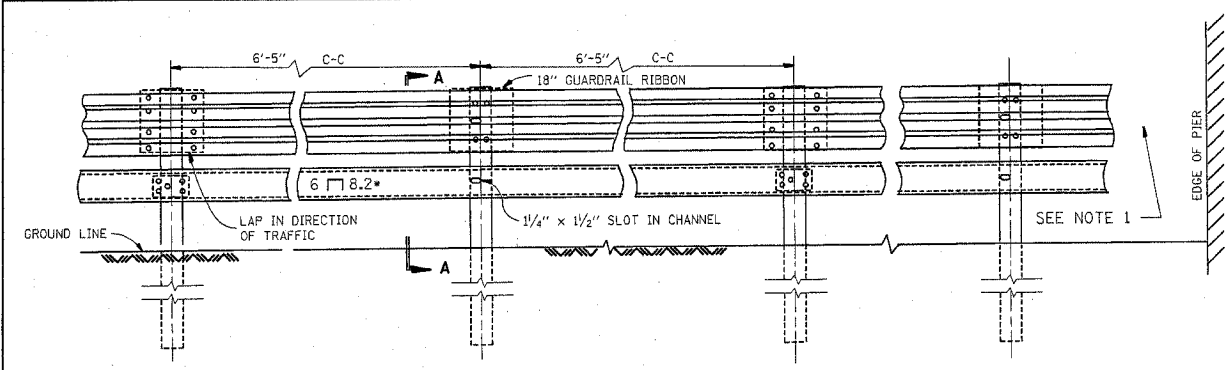

ELEVATION

DETAIL OF END SECTION

NOTE 1:
FOR DETAILS OF GUARDRAIL END ANCHORAGE
AT PIERS, SEE SHEET NO. ___

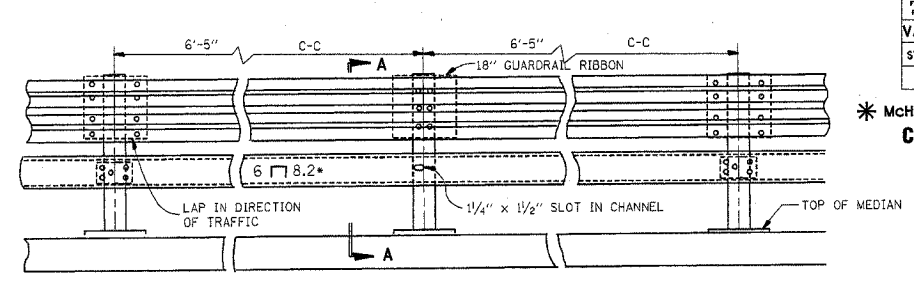

ELEVATION

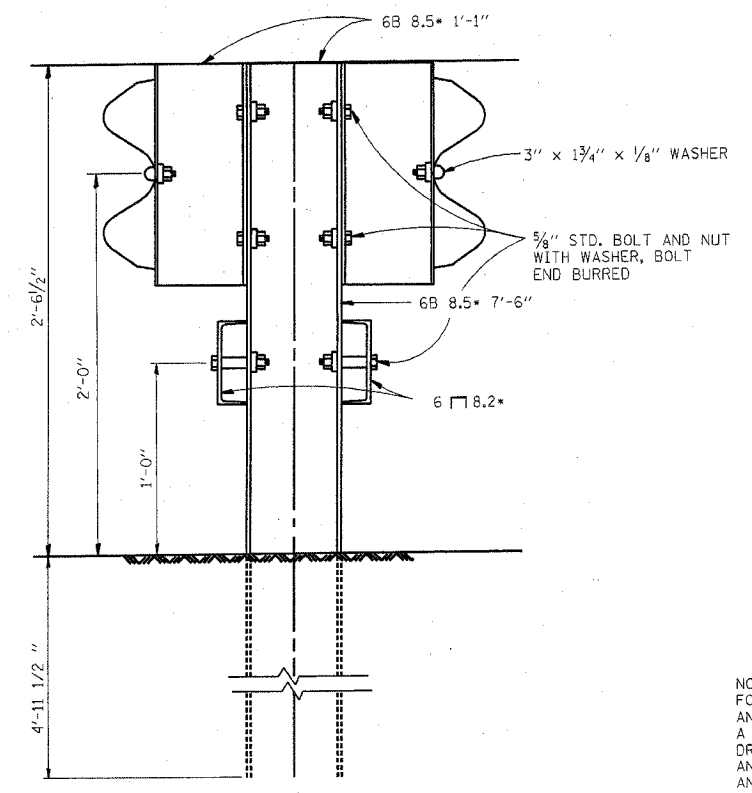

SECTION A-A

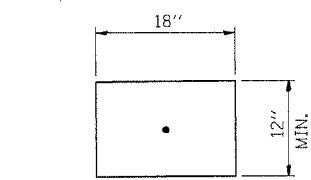

18" GUARDRAIL ELEMENT SPLICE

NOTE:
FOR DETAIL OF RAIL ELEMENT, RAIL SPlicing, BOLT,
AND NUT, SEE STATE STANDARD 630001.
A 1 3/8" x 3" x 1/8" STEEL PLATE WASHER AS SHOWN ON THIS
DRAWING SHALL BE PLACED BETWEEN THE BOLT HEAD
AND THE GUARDRAIL RIBBON AT ALL MOUNTING POINTS.
AN 18" PIECE OF GUARDRAIL RIBBON SHALL BE INSERTED
BETWEEN THE CONTINUOUS RIBBON AND THE POST AT
NON-SLICE MOUNTING POINTS.
RAIL, CHANNELS, POSTS, BASE PLATES, FASTENINGS,
AND ALL OTHER EXPOSED ACCESSORIES SHALL BE
GALVANIZED.

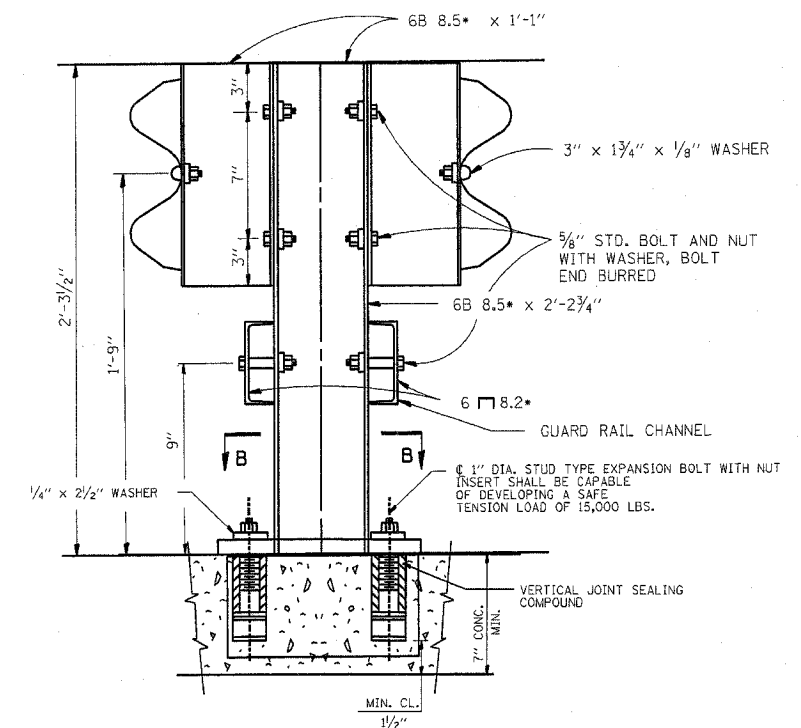

SECTION A-A
ANCHORAGE DETAIL

NOTE:
ALL WELDS SHALL BE GROUND SMOOTH.
POSTS SHALL BE CUT AND WELDED TO THE
BASE PLATE SO THAT THE POSTS WILL BE
PLUMB WHEN ERECTED.

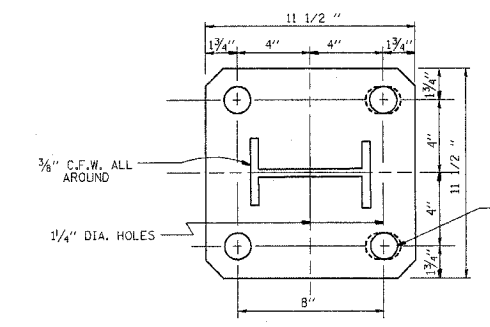

RAIL POST BASE PLATE
R 11 1/2" x 1 1/4" x 1 1/2"

SECTION B-B

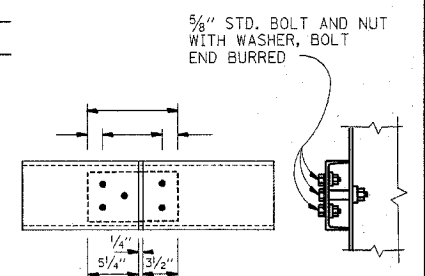

CHANNEL SPLICE
PLATE 8 3/4" x 4 1/2" x 1/4"

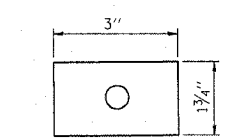

WASHER
PLATE 3" x 1 3/4" x 1/8"

REVISIONS	
NAME	DATE

ILLINOIS DEPARTMENT OF TRANSPORTATION
**STEEL PLATE BEAM GUARDRAIL
SPECIAL**

SCALE: NONE
DATE: 10/2/2006
DRAWN BY R.F.L.
CHECKED BY

THIS SHEET IS FOR INFORMATION ONLY

F. L. REC.	SECTION	COUNTY	TOTAL SHEETS	SHEET NO.
VAR.	2005-027 GRR	*	19	14
STA.	TO STA.			
FED. ROAD DIST. NO.	ILLINOIS	FED. AID PROJECT		

* MCHENRY, LAKE, KANE, COOK AND DUPAGE
CONTRACT 62961

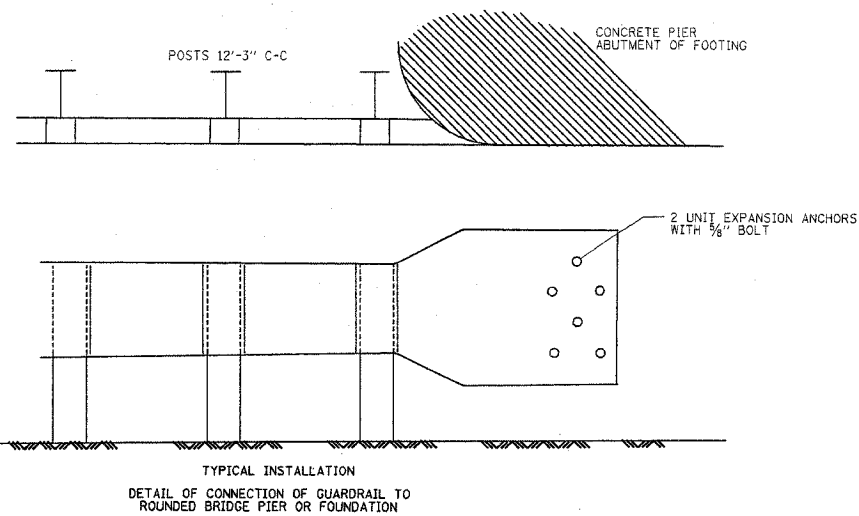
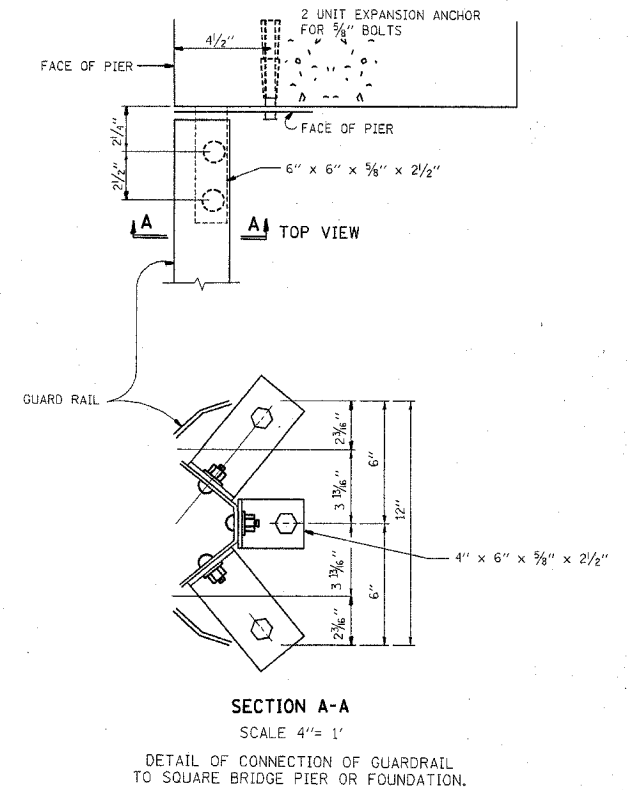
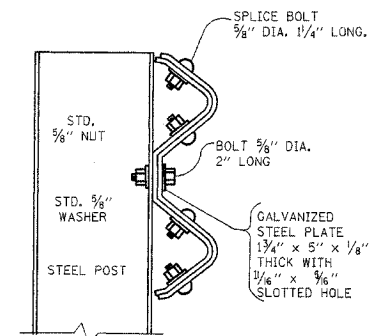
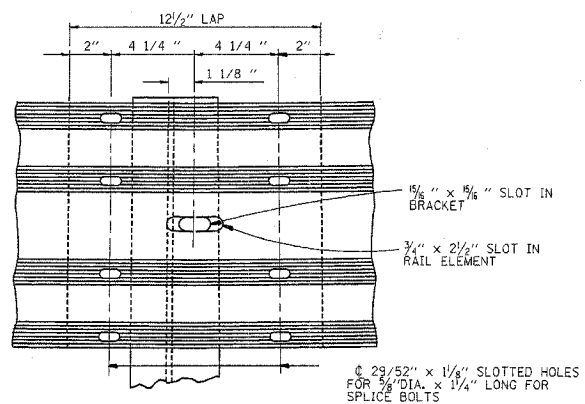
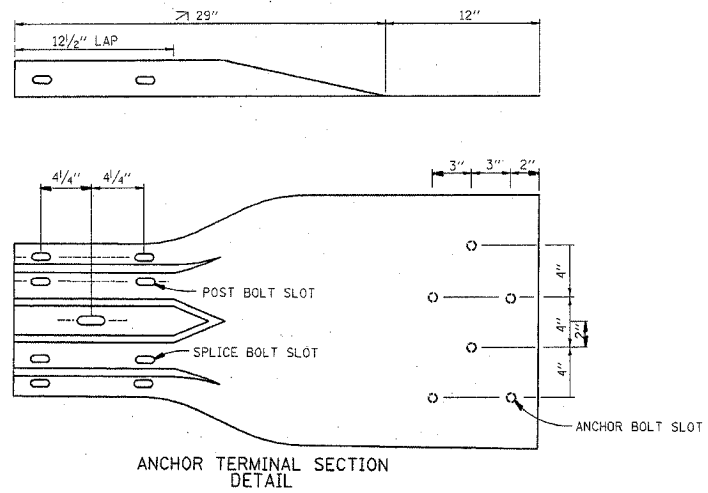

REVISIONS	
NAME	DATE
CREATED	10-31-88

ILLINOIS DEPARTMENT OF TRANSPORTATION
DETAIL OF GUARDRAIL SUPPORT AND END ANCHORAGE
SCALE: NONE
DATE: 10/2/2006
DRAWN BY: R.F.L.
CHECKED BY:

THIS SHEET IS FOR INFORMATION ONLY

S. A. ETC.	SECTION	COUNTY	TOTAL SHEETS	SHEET NO.
VAR.	2005-027 GRR	*	19	15
STA.	TO STA.			
FED. ROAD DIST. NO.	ILLINOIS	FED. AID PROJECT		

CONTRACT 62961
 * McHENRY, LAKE, KANE, COOK AND DUPAGE

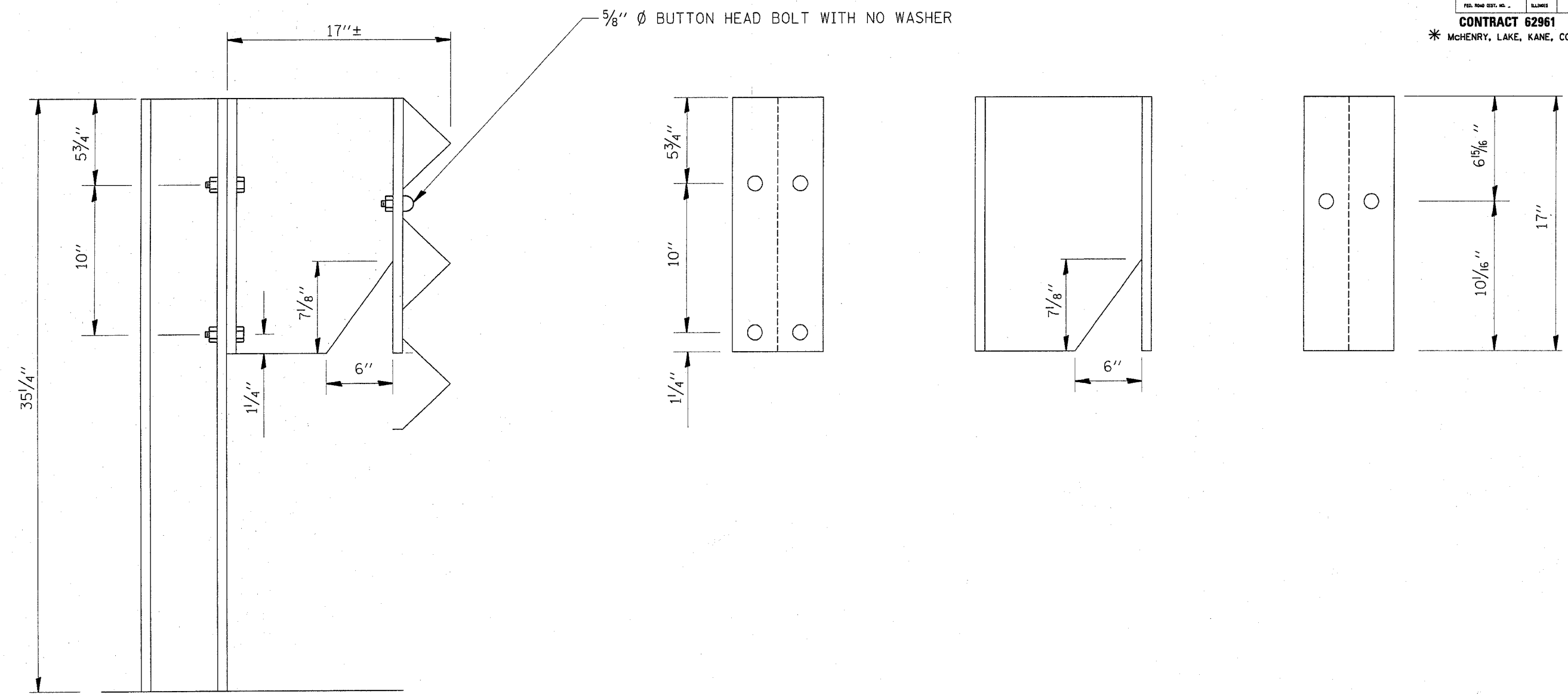

VI-TBG-N
 10/2/2006
 ct:projects@m106188@m06188bb.m32

REVISIONS	
NAME	DATE

ILLINOIS DEPARTMENT OF TRANSPORTATION

DETAIL
THREE BEAM GUARDRAIL
WITH MODIFIED OFFSET BLOCK

SCALE: NONE
 DATE: 10/2/2006

DRAWN BY
 CHECKED BY

F. & S. NO.	SECTION	COUNTY	TOTAL SHEETS	SHEET NO.
VAR	2005-0210AE	VAE	19	16
STA.	TO STA.			
FED. ROAD DIST NO. 7	ILLINOIS	FED. AID PROJECT		

CONTRACT 02 941

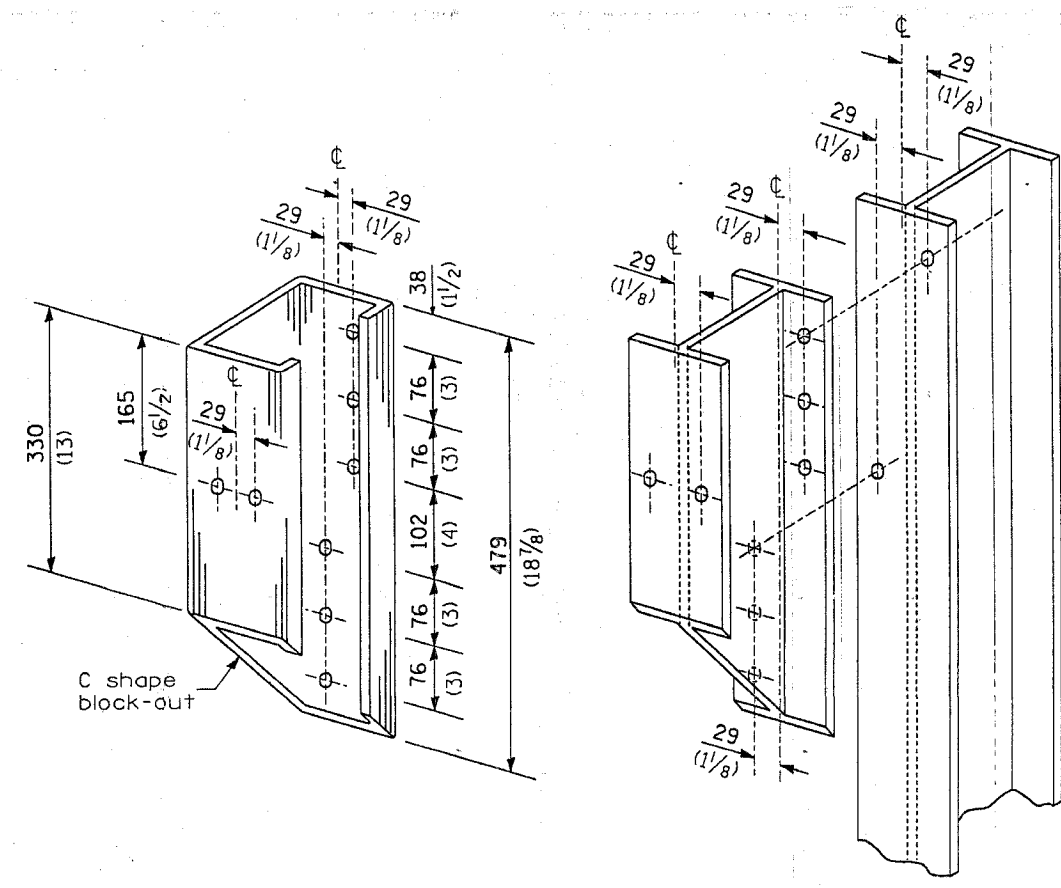

STEEL BLOCK-OUT AND
STEEL POST DETAILS

REVISIONS	
NAME	DATE

ILLINOIS DEPARTMENT OF TRANSPORTATION

STEEL PLATE BEAM GUARDRAIL
STEEL BLOCK-OUT DETAIL

SCALE: VERT.
HORIZ.
DATE

DRAWN BY
DESIGNED BY
CHECKED BY

F. A. DIST.	SECTION	COUNTY	TOTAL SHEETS	SHEET NO.
VAR	2005-027 GAA	VARIOUS	19	17
STA.		TO STA.		
FED. ROAD DIST. NO. 7	ILLINOIS	FED. AID PROJECT		
Contract - 62961				

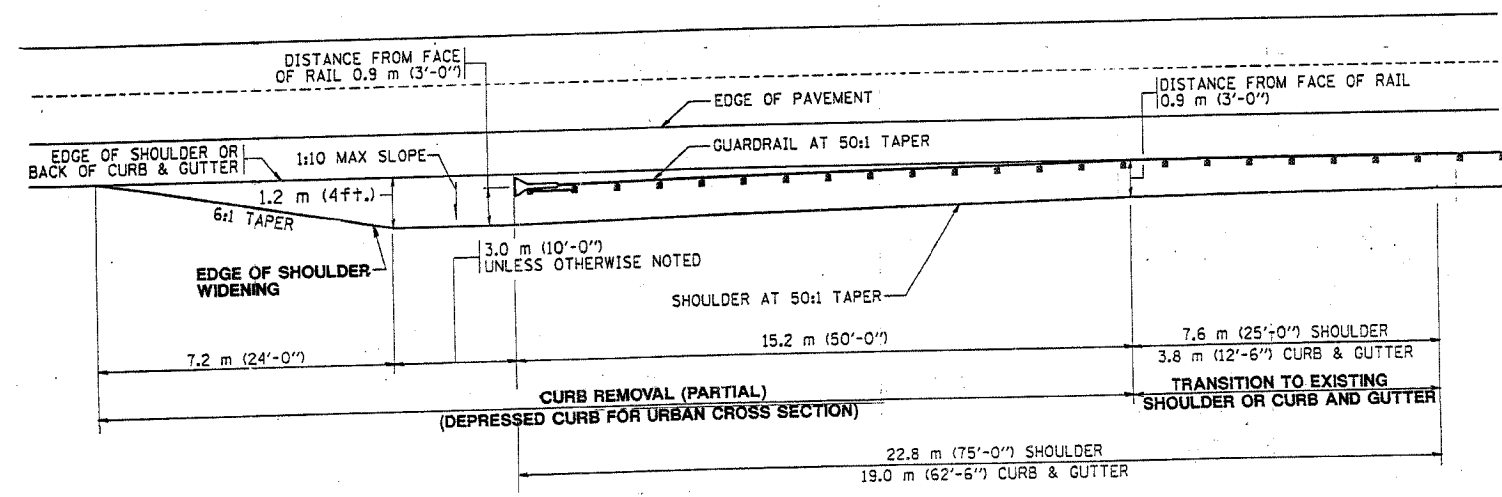

NOTE: SHOULDER WIDENING SHALL BE IN ACCORDANCE WITH STATE STANDARD 630301

REVISIONS	
NAME	DATE

ILLINOIS DEPARTMENT OF TRANSPORTATION

CURB REMOVAL (PARTIAL) FOR TRAFFIC BARRIER TERMINAL, TYPE 1 SPECIAL

SCALE: VERT. _____
 HORIZ. _____

DATE _____

DRAWN BY _____
 DESIGNED BY _____
 CHECKED BY _____

84 IN INDUSTRIES BOARD

STATE OF ILLINOIS
DEPARTMENT OF TRANSPORTATION

ROUTE NO.	SECTION	COUNTY	SHEET	SHEET NO.
V.A.		VARIOUS	19	18
FED. ROAD DIST. NO. 7	ILLINOIS	FED. AID PROJECT		

Contract # 62961

NOTES

Hollow structural sections shall conform to the requirements of ASTM designation A 500, Grade B, Structural Steel Tubing and shall meet the longitudinal CVN requirements of 15 ft-lbs at 0°F.

All posts, railing, rail splices and anchor rods shall conform to the requirements of AASHTO M 270 Grade 36 except posts shall conform to AASHTO M 270, Grade 50.

Bolts, cap screws and nuts shall conform to the requirements of ASTM designation A 307 except that threaded rods, nuts and washers shall conform to AASHTO M 164.

All bolts, nuts, cap screws, washers and lock washers shall be galvanized according to AASHTO M 232.

All posts, railing, rail splices and anchor rods shall be galvanized after shop fabrication according to AASHTO M 111 and ASTM A 385. Galvanized rail shall not be painted.

Railing shall be according to Section 509 of the Standard Specifications, except as noted, and will be paid for at the contract unit price per foot for Steel Bridge Rail.

All field drilled holes shall be coated with an approved zinc rich paint before erection.

Posts shall not be located closer than 1'-3" to an existing bridge expansion joint or end of bridge.

Steel Bridge Rail expansion joint shall be provided between any two (2) posts which span a bridge expansion joint. Bolts located at expansion joint shall be provided with locknuts and shall be tightened only to a point that will allow railing movement.

Provide one 1/8" and two 1/16" steel shims for 25% of the posts. Shims shall be similar to base plates in size and holes.

Expansion joint width shall be "D" at 50°F and shall be adjusted for other temperatures according to Article 503.10(c) of the Standard Specifications.

The Contractor shall use the capsule or the adhesive cartridge type anchor rods that have been previously tested and given a prior approval by the Department. The Contractor shall install these anchor rods in pre-drilled holes according to the manufacturer's recommendations and procedures. The capsule or the adhesive cartridge shall be sealed with pre-measured amounts of the adhesive chemical.

Nuts for 1" φ threaded anchor rods connecting the base plate to the concrete shall be tightened to a snug fit and given an additional 1/2 turn.

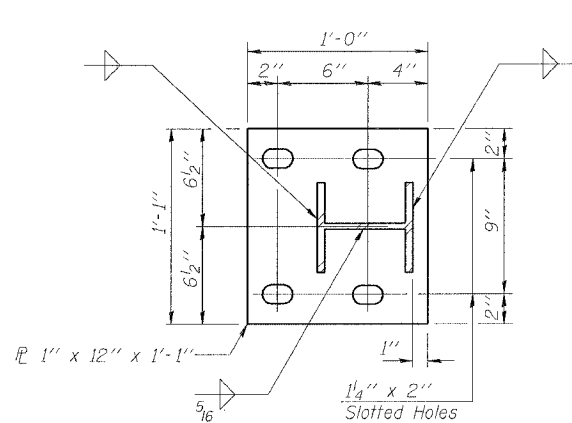

BASE PLATE DETAIL

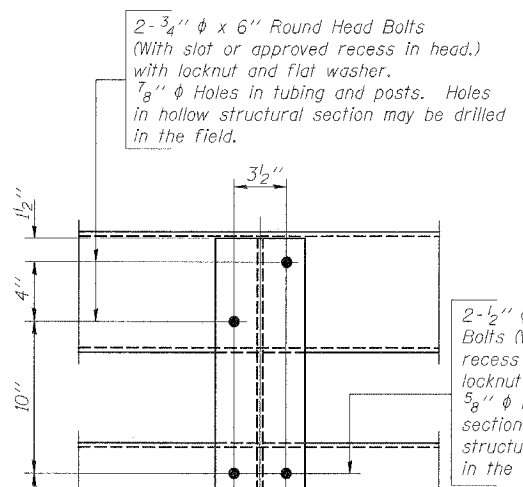

SECTION A-A

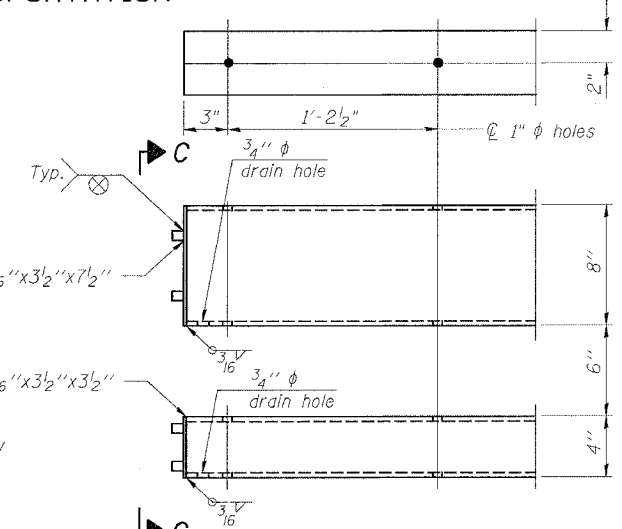

END OF RAIL DETAILS

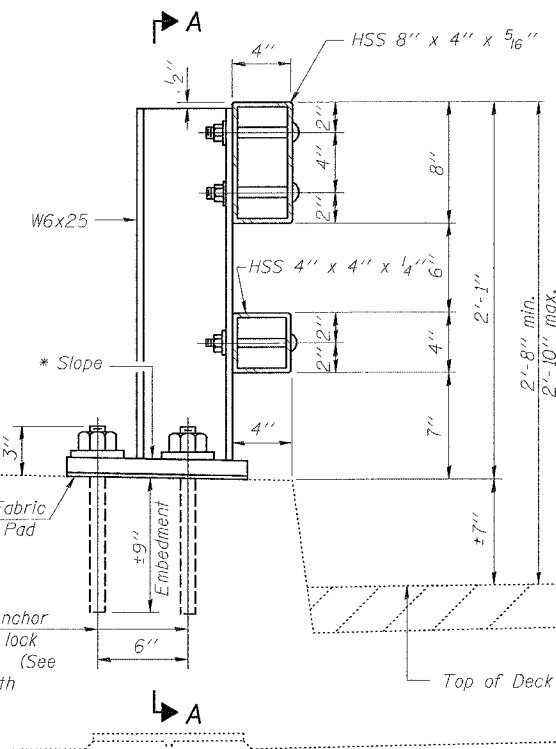

SECTION AT RAIL POST

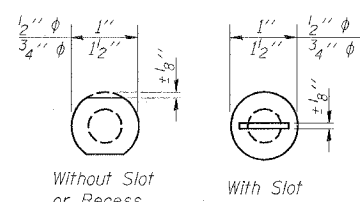

VIEW B-B

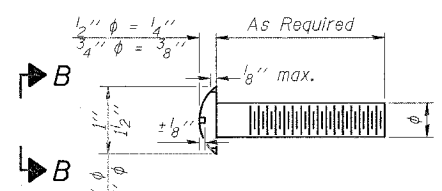

DETAIL OF 1/2" φ & 3/4" φ ROUND HEAD BOLTS

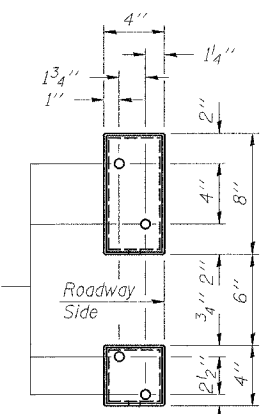

VIEW C-C

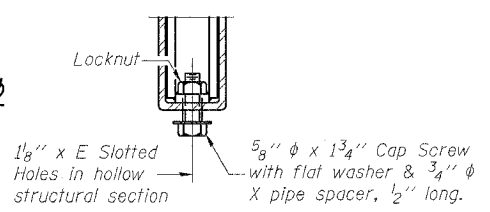

RAIL SPLICE CONNECTION AT EXPANSION JT.

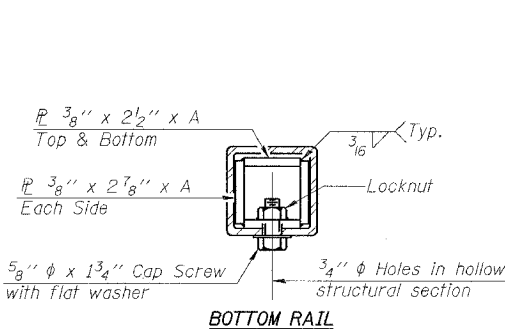

BOTTOM RAIL

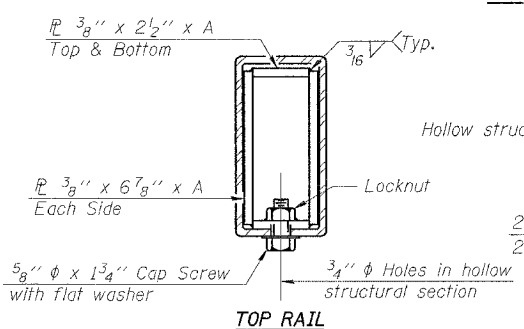

TOP RAIL

SECTIONS AT RAIL SPLICE

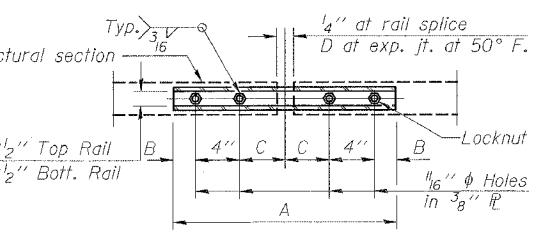

PLAN-BOTT. SPLICE R TYPICAL

BILL OF MATERIAL

Item	Unit	Quantity
Steel Bridge Rail	Foot	

SPLICE DIMENSIONS

T	D	A	B	C	E
≤ 4"	2 1/2"	1'-8"	2"	4"	2 1/2"
> 4" ≤ 6 1/2"	3 3/4"	2'-0"	2 1/2"	5 1/2"	3 1/2"
> 6 1/2" ≤ 9"	5"	2'-4"	3 1/2"	6 1/2"	9"
> 9" ≤ 13"	7"	2'-10"	4 1/2"	8 1/2"	11"
Rail Splice	1/4"	1'-8"	2"	4"	---

T = Total movement at expansion joint as shown on the design plans.

STEEL BRIDGE RAIL CURB MOUNTED (2399)

DESIGNED -	200
CHECKED -	EXAMINED
DRAWN -	PASSED
CHECKED -	ENGINEER OF BRIDGE DESIGN
	ENGINEER OF BRIDGES AND STRUCTURES

(6'-3" Maximum Post Spacing)

F.A. RTE.	SECTION	COUNTY	TOTAL SHEETS	SHEET NO.
Via	100010-48	Via	19	19
STA.	TO STA.			
FED. ROAD DIST. NO.	ILLINOIS	FED. AID PROJECT		

PARTIAL RAMP CLOSURE DETAILS

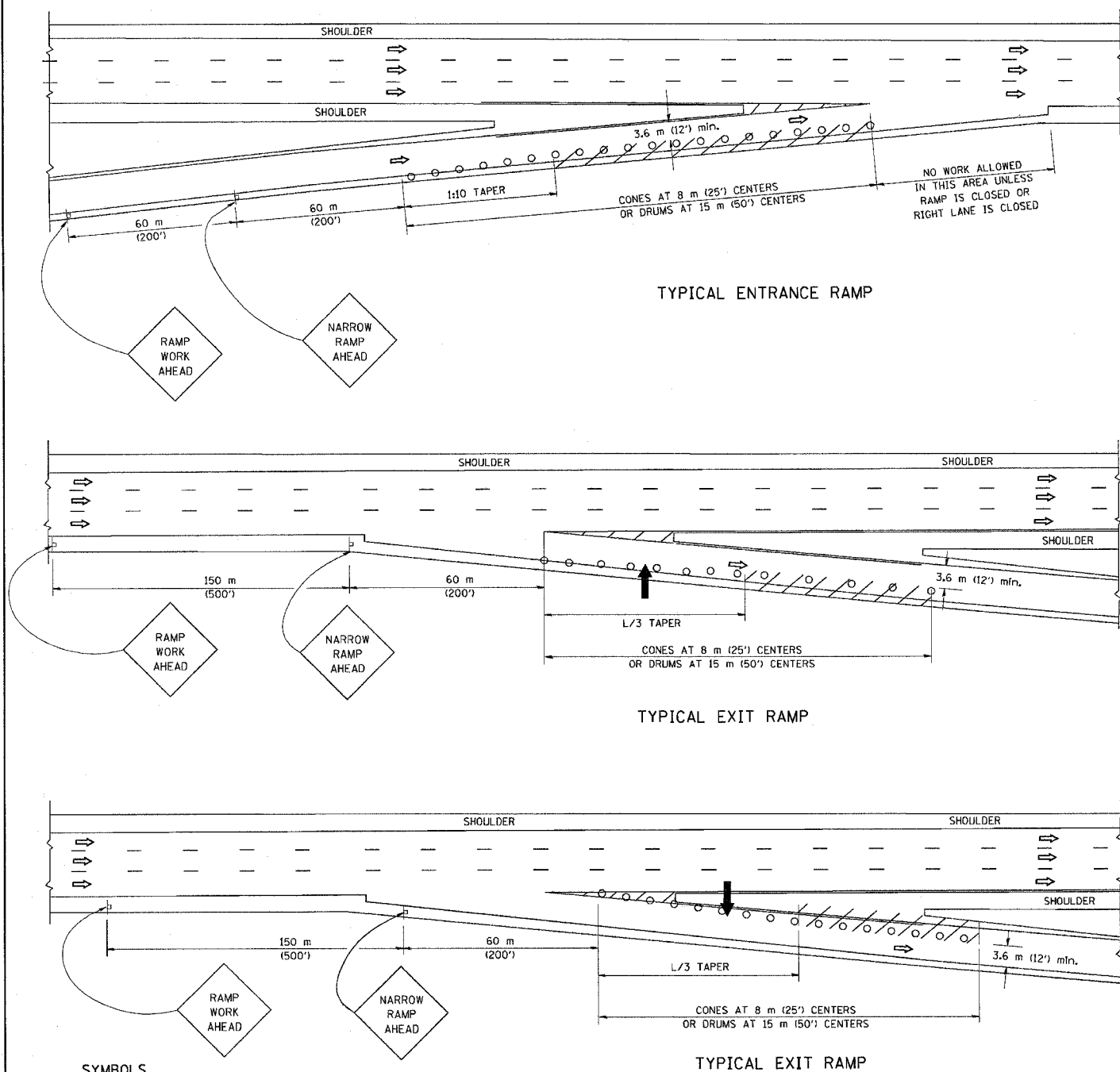

SYMBOLS

- ARROWBOARD
- WORK AREA
- SIGN ON PORTABLE OR PERMANENT SUPPORT
- FLAGGER WITH CONTROL SIGN
- DRUM WITH MONO-DIRECTIONAL STEADY BURNING LIGHT
- CONES - 700 (28) IN HEIGHT

GENERAL NOTES

1. THE "L" DISTANCE EQUALS:

SPEED LIMIT	FORMULAS
80 km/h (45 mph)	METRIC ENGLISH
OR GREATER:	$L=0.65(W)(S)$ $L=(W)(S)$

W = WIDTH OF OFFSET IN METERS (FEET)
S = NORMAL POSTED SPEED KM/H (MPH)
2. PLASTIC DRUMS WITH HIGH PERFORMANCE REFLECTIVE SHEETING AND STEADY BURNING LIGHTS ARE REQUIRED FOR ALL NIGHTTIME CLOSURES.
3. ALL SIGNS SHALL BE POST MOUNTED IF THE CLOSURE TIME EXCEEDS FOUR DAYS.
4. FLASHING LIGHTS SHALL BE USED DURING THE HOURS OF DARKNESS AND SHALL BE INSTALLED ABOVE THE FIRST TWO SETS OF SIGNS.

SHOULDER CLOSURE DETAILS

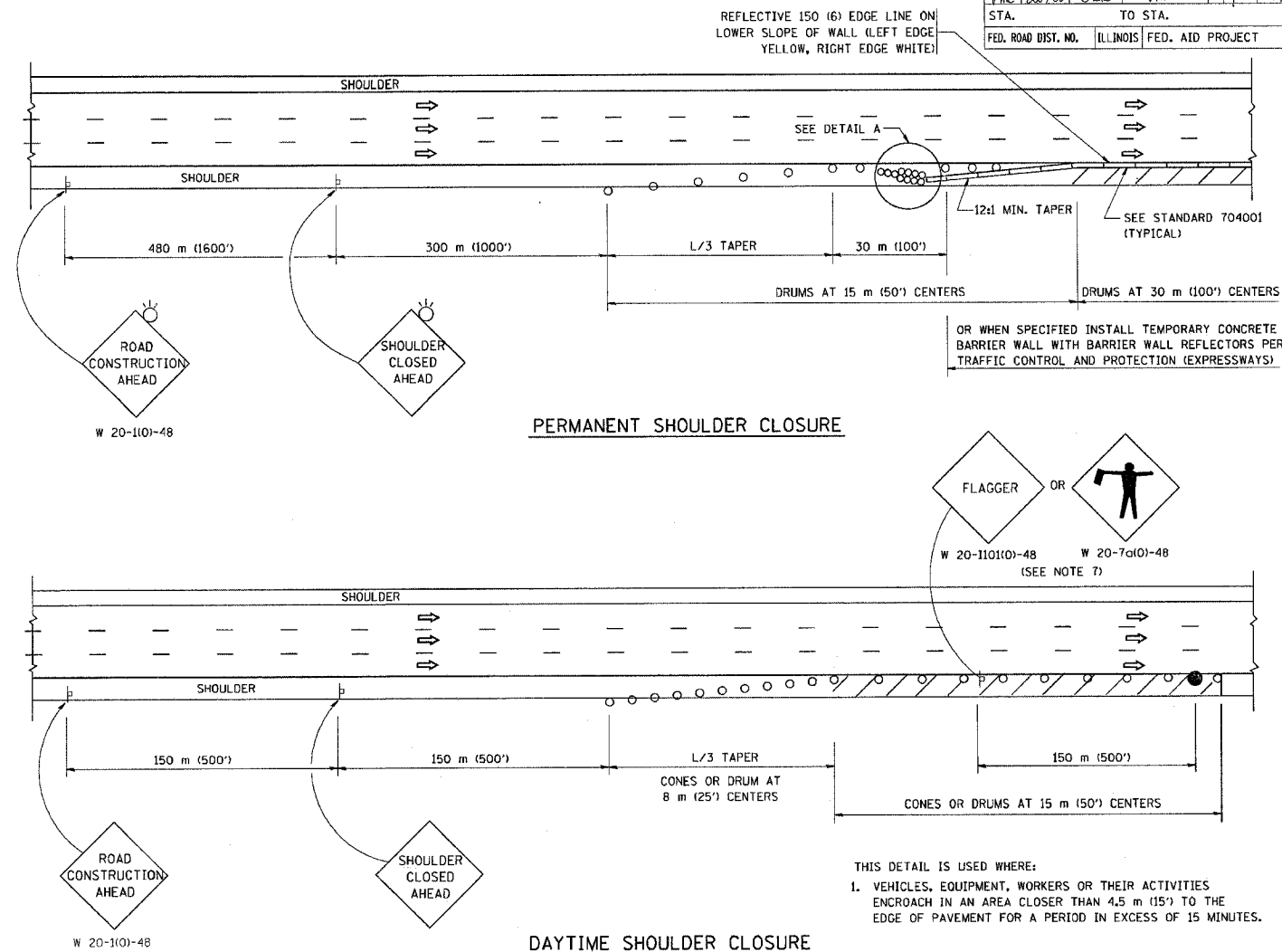

PERMANENT SHOULDER CLOSURE

DAYTIME SHOULDER CLOSURE

THIS DETAIL IS USED WHERE:
1. VEHICLES, EQUIPMENT, WORKERS OR THEIR ACTIVITIES ENCR OACH IN AN AREA CLOSER THAN 4.5 m (15') TO THE EDGE OF PAVEMENT FOR A PERIOD IN EXCESS OF 15 MINUTES.

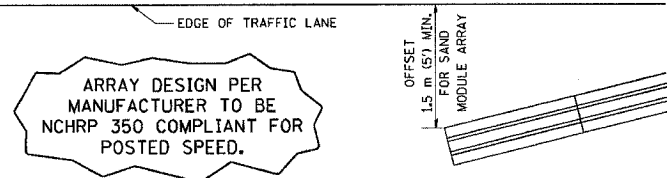

DETAIL "A"
IMPACT ATTENUATOR, TEMPORARY
(SEE NOTE 5)

5. THE IMPACT ATTENUATOR, TEMPORARY IS NOT REQUIRED WHEN THE TEMPORARY CONCRETE BARRIER WALL IS PROTECTED BY OR IS TIED INTO THE EXISTING GUARDRAIL. IF OFFSET IS LESS THAN 5 FEET USE "TRAFFIC BARRIER TERMINAL, TYPE III, TEMPORARY" DEVICE TO MEET NCHRP350 FOR POSTED SPEED.
6. AUTHORIZATION FROM THE DISTRICT'S BUREAU OF TRAFFIC IS REQUIRED FOR ALL FREEWAY CLOSURES.
7. THE FLAGGER AND FLAGGER SIGN ARE REQUIRED AT THE ABOVE WORK SITES WHEN:
 - a. FOUR OR MORE WORK VEHICLES ENTER THE TRAFFIC LANES IN A ONE HOUR PERIOD.
 - b. THE WORK ACTIVITY REQUIRES FREQUENT ENCR OACHMENT INTO THE LANE OPEN TO TRAFFIC.
 THE FLAGGER SHALL BE STATIONED APPROXIMATELY 30 m (100') TO 60 m (200') IN ADVANCE OF THE WORKERS.

ALL DIMENSIONS ARE IN MILLIMETERS (INCHES) UNLESS OTHERWISE SHOWN.

REVISIONS	
NAME	DATE
DWS	11/96
JAF	12/02
NCHRP 350	04/03
JAF	2/06

ILLINOIS DEPARTMENT OF TRANSPORTATION
TRAFFIC CONTROL DETAILS
FOR FREEWAY
SHOULDER CLOSURES
PARTIAL RAMP CLOSURES

SCALE: NONE
DATE: 3/1/2006

DESIGNED BY: DWS
DRAWN BY:
CHECKED BY: