

STATE OF ILLINOIS
DEPARTMENT OF TRANSPORTATION

ROUTE NO.	SECTION	COUNTY	STATE SHEETS	SHEET NO.	SHEET NO. 11 36 SHEETS
F.A.P. 315	34-6, 55-1	HANCOCK	433	209	
FED. ROAD DIST. NO. 7	ILLINOIS	FED. AID PROJECT			

Contract #68206

Joint Size	"C" at 50°F	"D" at 50°F
2"	2"	1 1/2" Min.
2 1/2"	2 1/2"	1 3/4" Min.
4"	3"	2 1/2" Min.

INSTALLATION NOTES

- Install continuous seal in roadway, parapet, curb, and sidewalk.
- Install anchor blocks as indicated.

Note A:
Maximum spacing of anchor bolts shall be 12" centers.

SKREW LIMITATIONS

The details of the anchor blocks and the elastomeric membrane in the parapet, as shown, are for up to 50° skews. For skews greater than 50°, the anchor blocks and the elastomeric membrane, installed according to dimension "D", might require modifications to insure a minimum clearance of 1/2" from centerline of anchor studs to edge of parapet opening. The anchor blocks and the elastomeric membrane shall also be installed to the top of the parapet with the anchor studs spaced at ±12" cts.

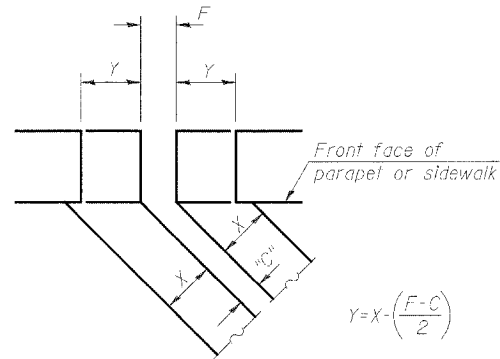

$$Y = X \cdot \left(\frac{F - C}{2} \right)$$

For dimension "F" see sheet 8 of 36.

FORMING BLOCKOUT SKETCH

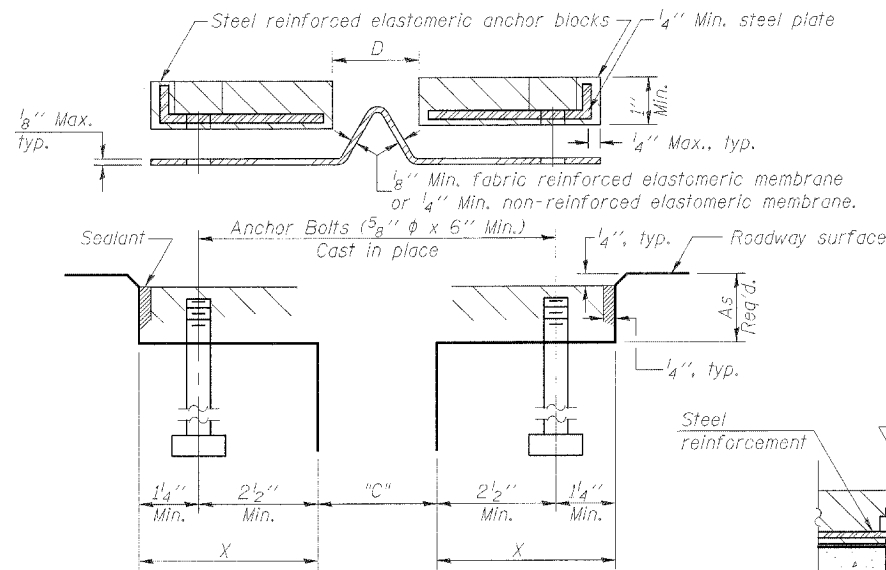

CROSS SECTION

ANCHOR BLOCK WITH ASPHALT SURFACE

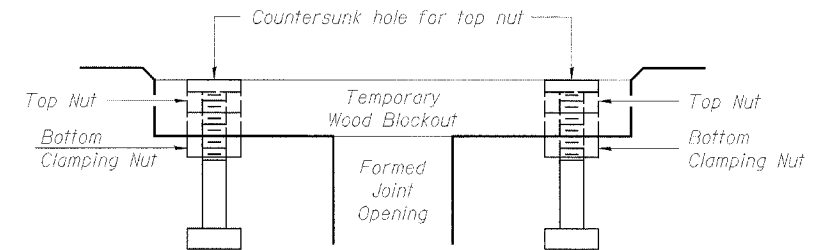

Note:
Stud needs to be threaded lower to allow for use of clamping nut.

Anchor studs should be stainless
RECOMMENDED BLOCKOUT DETAIL

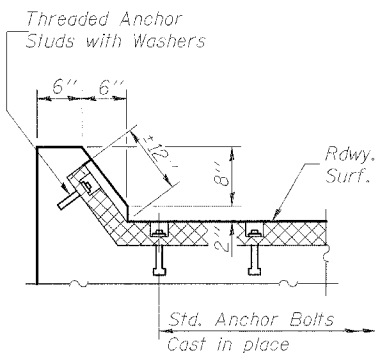

AT CURB

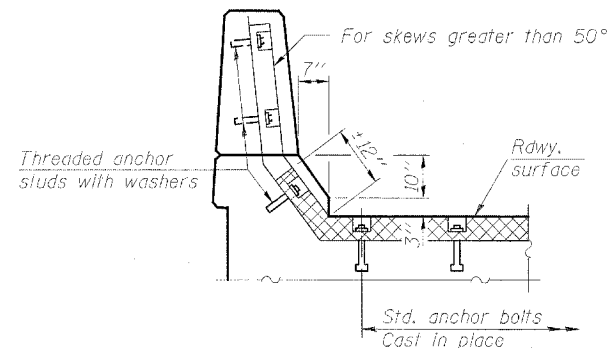

AT PARAPET

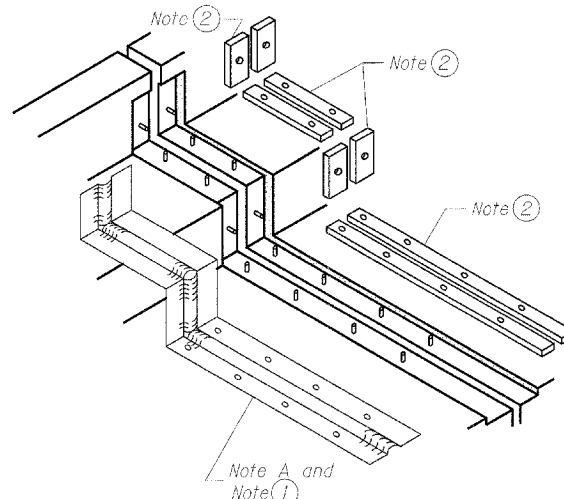

AT SIDEWALK OR MEDIAN

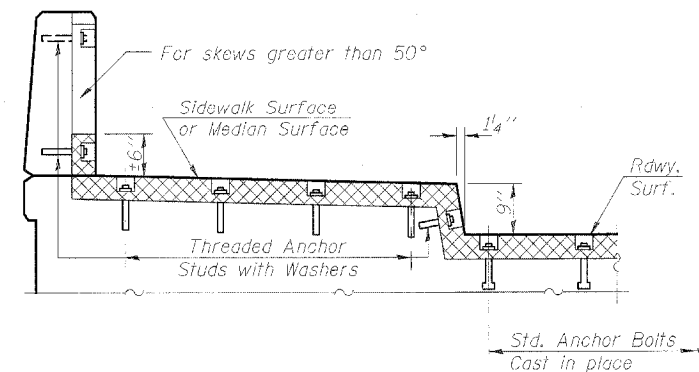

AT SIDEWALK OR MEDIAN TYPICAL END TREATMENTS

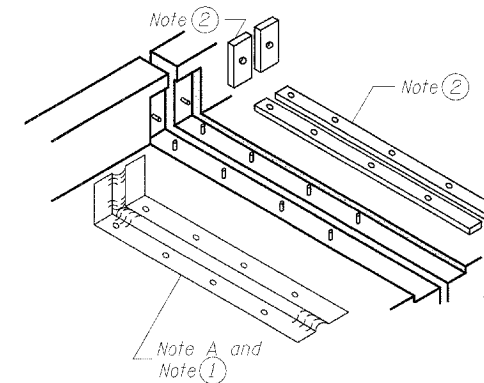

AT WALL

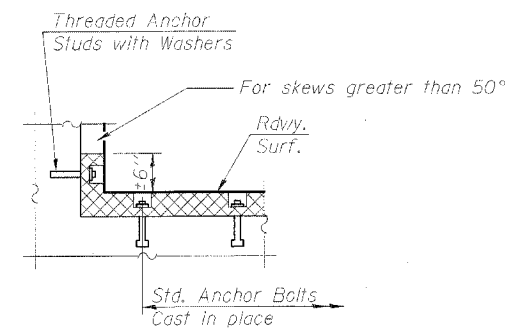

AT WALL

DESIGNED	KLH
CHECKED	EML
DRAWN	KBF
CHECKED	KLH
EJ-CS	

HORNER & SHIFRIN, INC.
ENGINEERS ■ ARCHITECTS ■ PLANNERS

9-01-03

**CONTINUOUS SEAL TYPE
NEOPRENE EXPANSION JOINTS
ILLINOIS ROUTE 336 OVER
EAST FORK OF THE LAMOINE RIVER
F.A.P. ROUTE 315 - SECTION 34-6, 55-1
HANCOCK COUNTY; STA. 1432+02.61
STRUCTURE NO. 034-0511 (E.B.)
STRUCTURE NO. 034-0512 (W.B.)**