

SECTION	COUNTY	TOTAL SHEETS	SHEET NO.
94-F3000-05-BT	COOK	102	72
STA.	TO STA.		
PROJECT NO. TE-D001 (610)			
CENTENNIAL TRAIL			

CONTRACT NO. 83859

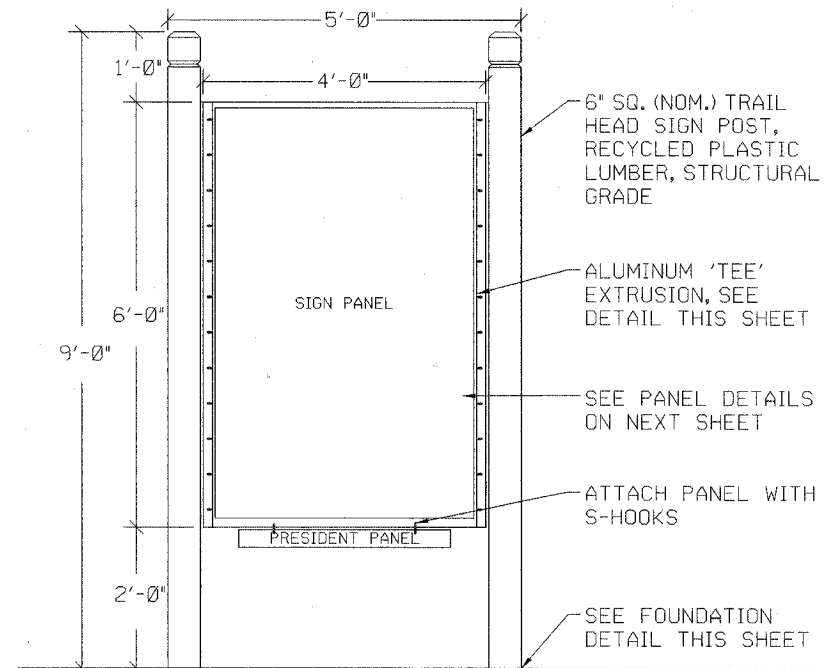

NOTES:
1. SHOP DRAWINGS SHALL BE SUBMITTED FOR APPROVAL.

TRAIL HEAD SIGN
N.T.S.

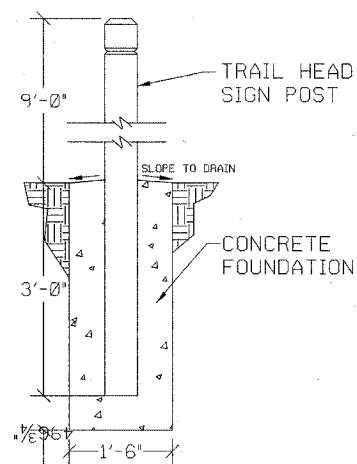

TRAIL HEAD POST FOUNDATION
N.T.S.

NOTES:

1. FASTEN TEE TO POST WITH #14 x 1.5" SIX-LOBE SECURITY SCREWS, BUTTON HEAD, TYPE SMS, STAINLESS STEEL AND WASHER.

2. FASTEN SIGN PANEL TO TEE WITH #14 x 1" SIX-LOBE SECURITY SCREWS, BUTTON HEAD, TYPE M/S, STAINLESS STEEL, ONE #14 WASHER AND ONE #14 TAMPER-PROOF NUT AS MANUFACTURED BY GUARD-NUT INC., SERIES 75, PLATED STEEL.

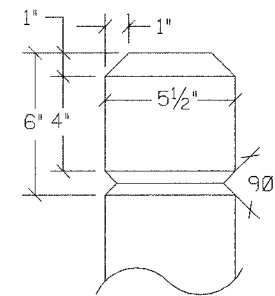

POST TOP DETAIL

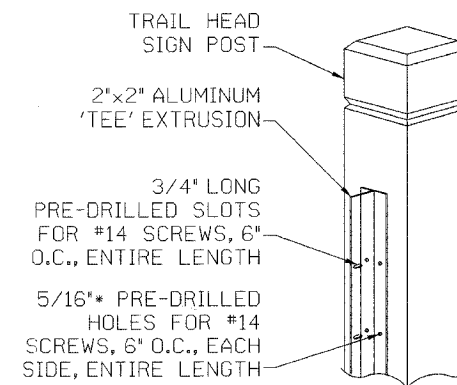

ALUMINUM EXTRUSION

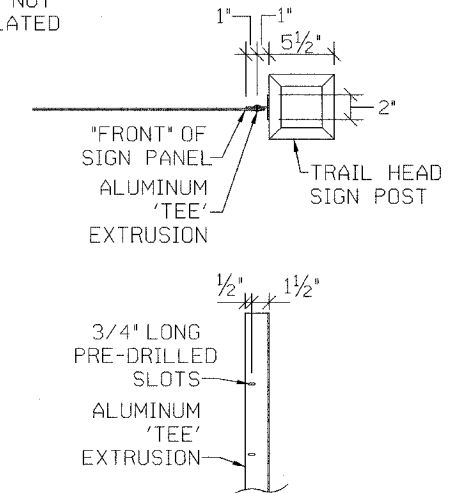

TRAIL HEAD POST DETAILS
N.T.S.

REVISIONS		
NO.	NAME	DATE

URS 100 S. WACKER DR., SUITE 500 TEL. (312) 939-1000
CHICAGO, IL 60606 FAX (312) 939-4198

FOREST PRESERVE DISTRICT OF COOK COUNTY
CENTENNIAL TRAIL

TRAIL HEAD SIGN DETAILS

DATE: 04/19/06 DRAWN BY:
DESIGNED BY: DGM CHECKED BY: DDL