

STATE OF ILLINOIS
DEPARTMENT OF TRANSPORTATION

GENERAL NOTES

Plan dimensions and details relative to existing structure have been taken from existing plans and are subject to nominal construction variations. It shall be the Contractor's responsibility to verify such dimensions and details in the field and make necessary approved adjustments prior to construction or ordering of materials. Such variations shall not be cause for additional compensation for a change in the scope of the work, however, the Contractor will be paid for the quantity actually furnished at the unit price bid for the work.

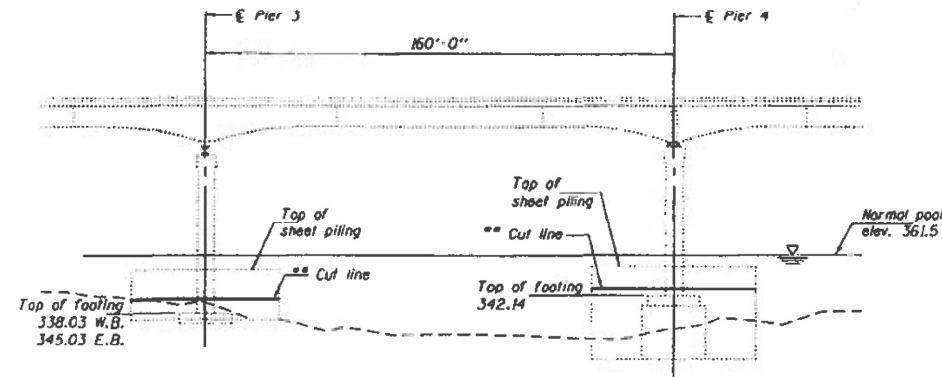

PARTIAL ELEVATION E.B. STRUCTURE

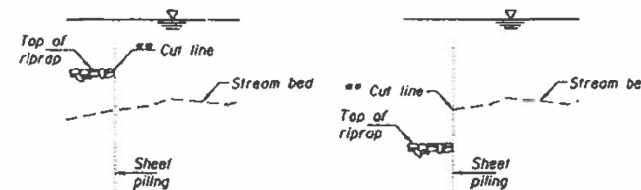

SECTION A-A

SECTION A-A

** Sheet piling to be cut to the elevation shown except that the cut elevation shall be the higher of the streambed elevation or the top of the riprap at the time of removal.

** Cut line elevation:
Pier 3, EB = 350.0
Pier 3, WB = 346.5
Pier 4, EB = 347.0
Pier 4, WB = 349.0

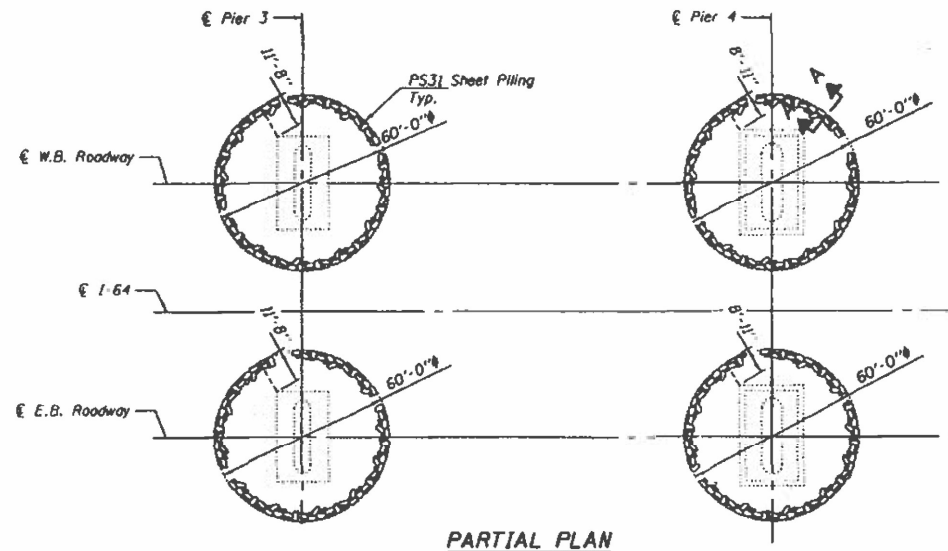

PARTIAL PLAN

TOTAL BILL OF MATERIAL

ITEM	UNIT	QUANTITY
Cutting and Removing Underwater Steel Sheet Piling Foot	Foot	500

* See Special Provisions

PARTIAL PLAN AND ELEVATION
I-64 / WABASH RIVER
SN 097-0003 & 0004

DESIGNED: J.S. H. V... JUN 18, 2009
CHECKED: [Signature]
DRAWN: [Signature]
CHECKED: VHV [Signature]

EXAMINED: [Signature]
PASSED: [Signature]



EXPIRES 11-30-2010

SHEET NO. 1 2 SHEETS	F.A.I. RTE.	SECTION	COUNTY	TOTAL SHEETS	SHEET NO.
	64	(97-2)I-1	WHITE	5	4
FED. ROAD DIST. NO.			ILLINOIS FED. AID PROJECT		
CONTRACT NO. 78140					

See sheet 2 of 2 for pile cutoff information

0970003.dgn 6/18/2009 9:49:45 AM

FOR INFORMATION ONLY

MODEL: I:\MODELS\NAME...
FILE: NAME: I:\TEG\CAD\Projects\Removal\0970003.dwg

KNIGHT
Engineers & Architects

USER NAME = USWV706141	DESIGNED - JS	REVISED -
PLOT SCALE = 1:2,00008	DRAWN - RTA	REVISED -
PLOT DATE = 8/10/2023	CHECKED - JCM	REVISED -
	DATE - 08/11/2023	REVISED -

STATE OF ILLINOIS
DEPARTMENT OF TRANSPORTATION

EXISTING CHANNEL PLAN AND ELEVATION

SCALE: SHEET R-13 OF 14 SHEETS STA. TO STA.

F.A.I. RTE.	SECTION	COUNTY	TOTAL SHEETS	SHEET NO.
64	(97-2) B-5	WHITE	578	101
CONTRACT NO. 78057				
ILLINOIS FED. AID PROJECT FAI 64/WABASH RIVER				

PLAN	SURVEYED	DATE
	PLOTTED	BY
	ALIGNED	
	CHECKED	
	FILE NAME	
	NO.	

PROFILE	SURVEYED	DATE
	PLOTTED	BY
	GRADES	
	CHECKED	
	STRUCTURE	
	NOTATION	
	NO.	

MODEL: S:\MODEL\NAMES
FILE NAME: E:\PROJECTS\I-64\I-64\Profile\EB\97-2\B-5\I-64-EB-PP-1.dwg

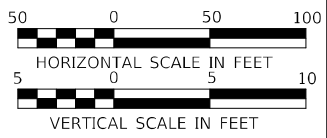
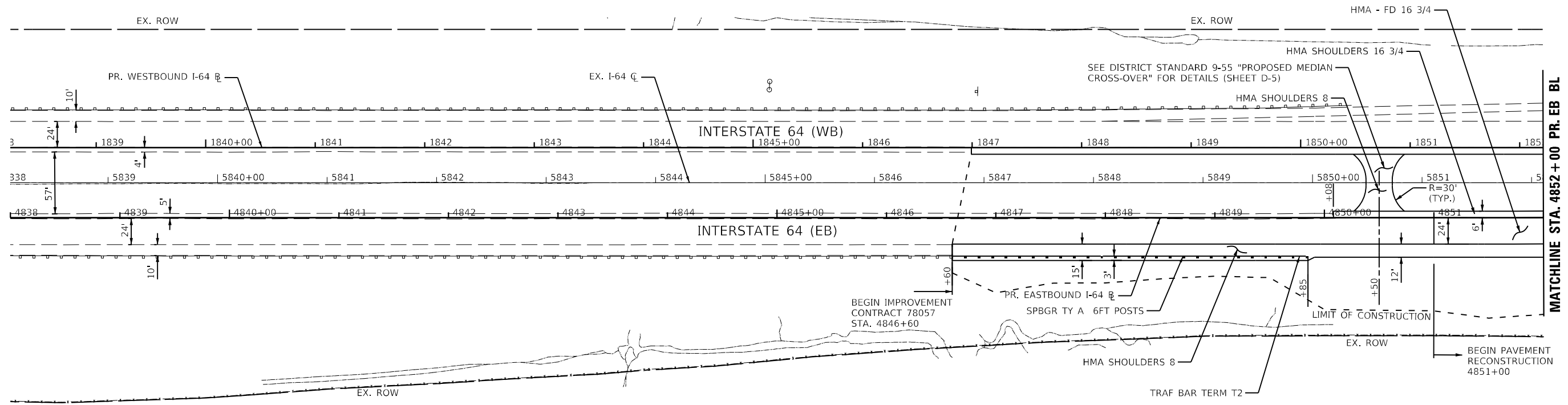

KNIGHT Engineers & Architects	USER NAME = USWV706141	DESIGNED - JS	REVISED -	STATE OF ILLINOIS DEPARTMENT OF TRANSPORTATION	ROADWAY PLAN AND PROFILE		F.A.I. RTE.	SECTION	COUNTY	TOTAL SHEETS	SHEET NO.
	PLOT SCALE = 1:100	CHECKED - JCM	REVISED -		EASTBOUND I-64		64	(97-2) B-5	WHITE	578	103
PLOT DATE = 8/24/2023	DATE = 08/11/2023	REVISED -		SCALE:	SHEET PP-1	OF 18 SHEETS	STA.	TO STA.	CONTRACT NO. 78057		
ILLINOIS FED. AID PROJECT FAI 64/WABASH RIVER											

PLAN	SURVEYED	BY	DATE
	PLOTTED		
	ALIGNED		
	CHECKED		
	FILED		
	CADD FILE NAME		
	NO.		

PROFILE	SURVEYED	BY	DATE
	PLOTTED		
	GRADES		
	CHECKED		
	STRUCTURE		
	NOTATION		
	NO.		

MODEL: S:\MODEL\NAMES
FILE NAME: E:\PROJECTS\CD\I-64\Sheet\Profile\EB\PP-2\18-57-shp-hpwr-4005.dgn

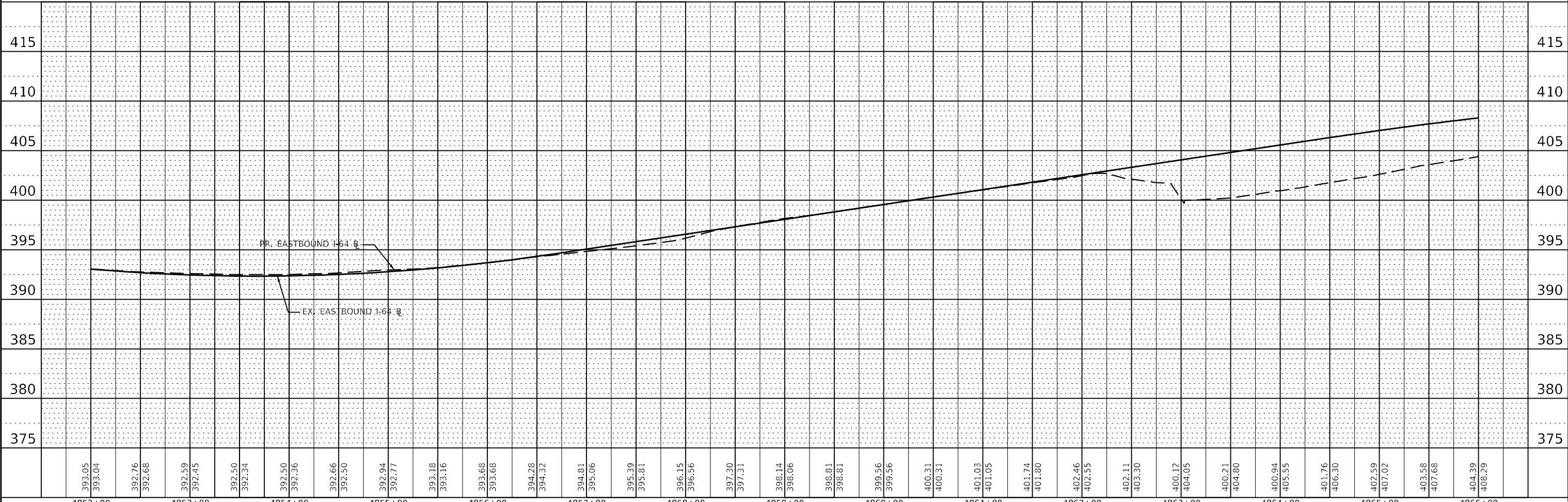
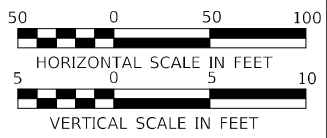
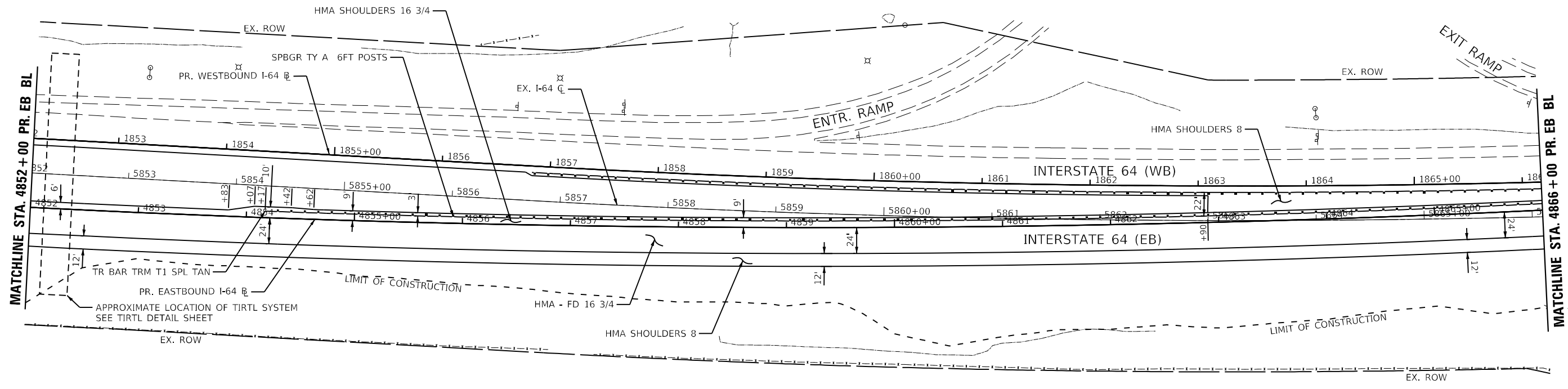

4852+00	4853+00	4854+00	4855+00	4856+00	4857+00	4858+00	4859+00	4860+00	4861+00	4862+00	4863+00	4864+00	4865+00	4866+00																																											
393.05	393.04	392.76	392.68	392.59	392.45	392.50	392.34	392.50	392.36	392.66	392.50	392.94	392.77	393.18	393.16	393.68	393.68	394.28	394.32	394.81	395.06	395.39	395.81	396.15	396.56	397.30	397.31	398.14	398.06	398.81	398.81	399.56	399.56	400.31	400.31	401.03	401.05	401.74	401.80	402.46	402.55	402.11	403.30	400.12	404.05	400.21	404.80	400.94	405.55	401.76	406.30	402.59	407.02	403.58	407.68	404.39	408.29

KNIGHT
Engineers & Architects

USER NAME = USWV706141	DESIGNED - JS	REVISED -
	DRAWN - RTA	REVISED -
PLOT SCALE = 1:100	CHECKED - JCM	REVISED -
PLOT DATE = 8/24/2023	DATE - 08/11/2023	REVISED -

STATE OF ILLINOIS
DEPARTMENT OF TRANSPORTATION

ROADWAY PLAN AND PROFILE	
EASTBOUND I-64	
SCALE:	SHEET PP-2 OF 18 SHEETS STA. TO STA.

F.A.I. RTE.	SECTION	COUNTY	TOTAL SHEETS	SHEET NO.
64	(97-2) B-5	WHITE	578	104
CONTRACT NO. 78057				
ILLINOIS FED. AID PROJECT FAI 64/WABASH RIVER				

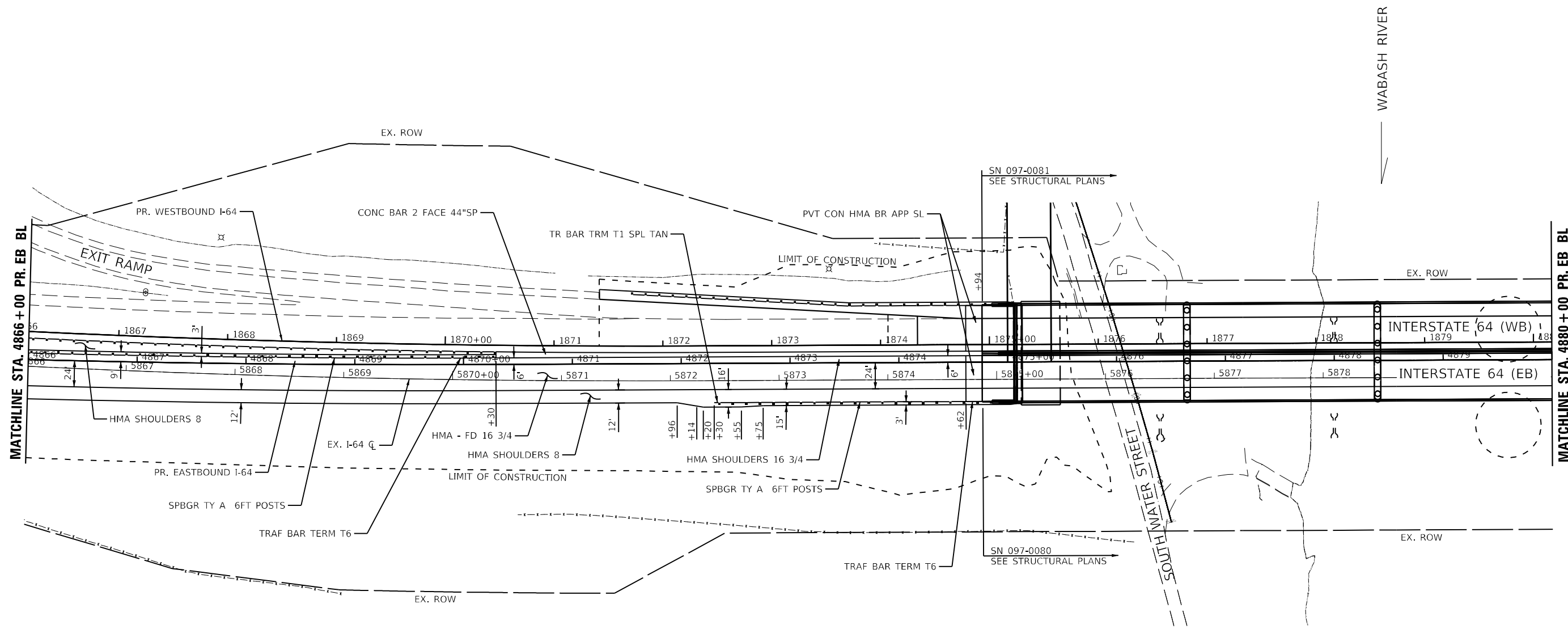

WABASH RIVER

SOUTH WATER STREET

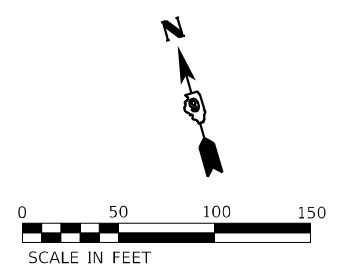

MODEL: I:\MODELS\I-64\EB\Profile\EB\0975057-sh-holm-4033a.dwg
 FILE NAME: I:\MODELS\I-64\EB\Profile\EB\0975057-sh-holm-4033a.dwg

KNIGHT
 Engineers & Architects

USER NAME = USWV706141	DESIGNED - JS	REVISED -
PLOT SCALE = 1:100	DRAWN - RTA	REVISED -
PLOT DATE = 8/24/2023	CHECKED - JCM	REVISED -
	DATE - 08/11/2023	REVISED -

STATE OF ILLINOIS
DEPARTMENT OF TRANSPORTATION

ROADWAY PLAN AND PROFILE
EASTBOUND I-64

SCALE: SHEET PP-3 OF 18 SHEETS STA. TO STA.

F.A.I. RTE.	SECTION	COUNTY	TOTAL SHEETS	SHEET NO.
64	(97-2) B-5	WHITE	578	105
CONTRACT NO. 78057				
ILLINOIS FED. AID PROJECT FAI 64/WABASH RIVER				

PLAN	STAMPED	DATE
	BY	
NOTE BOOK NO.	PLOTTED	
	GRADES CHECKED	
NO.	ALIGNMENT CHECKED	
	CADD FILE NAME	

PROFILE	STAMPED	DATE
	BY	
NOTE BOOK NO.	PLOTTED	
	GRADES CHECKED	
NO.	STRUCTURE NOTATION UPWD	

MODEL: S:\MODEL\NAMES
FILE NAME: I:\78057\CADD\Struct\Plan_Profile\I-64\I-64_Plan_Profile.dwg

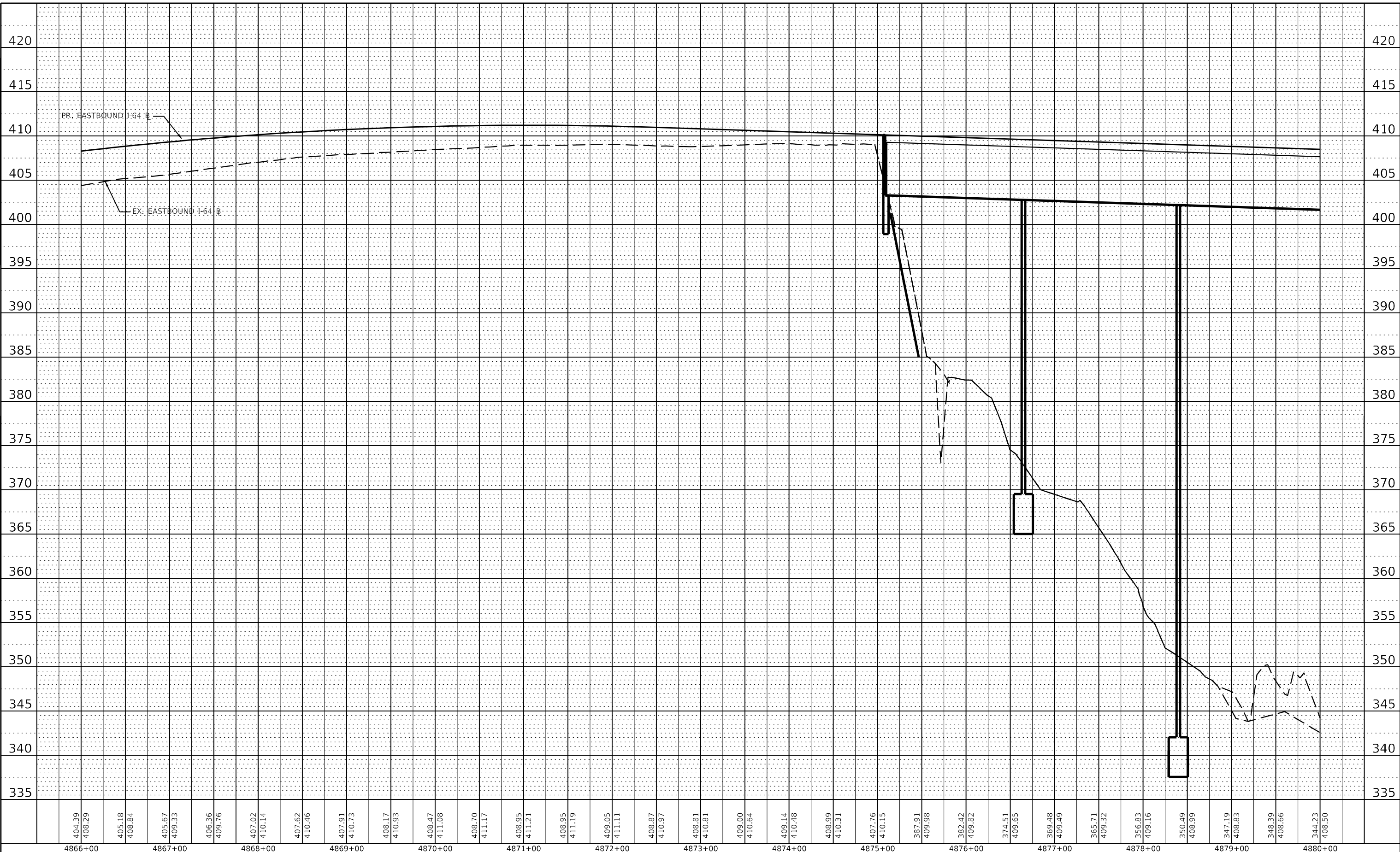

404.39	408.29	405.18	408.84	405.67	409.33	406.36	409.76	407.02	410.14	407.62	410.46	407.91	410.73	408.17	410.93	408.47	411.08	408.70	411.17	408.95	411.21	408.95	411.19	409.05	411.11	408.87	410.97	408.81	410.81	409.00	410.64	409.14	410.48	408.99	410.31	407.76	410.15	387.91	409.98	382.42	409.82	374.51	409.65	369.48	409.49	365.71	409.32	356.83	409.16	350.49	408.99	347.19	408.83	348.39	408.66	344.23	408.50
4866+00	4867+00	4868+00	4869+00	4870+00	4871+00	4872+00	4873+00	4874+00	4875+00	4876+00	4877+00	4878+00	4879+00	4880+00																																											



USER NAME = USWV706141	DESIGNED - JS	REVISED -
DRAWN - RTA	REVISED -	
PLLOT SCALE = 1:100	CHECKED - JCM	REVISED -
PLLOT DATE = 8/24/2023	DATE - 08/11/2023	REVISED -

STATE OF ILLINOIS
DEPARTMENT OF TRANSPORTATION

ROADWAY PLAN AND PROFILE
EASTBOUND I-64

SCALE: SHEET PP-4 OF 18 SHEETS STA. TO STA.

F.A.I. RTE.	SECTION	COUNTY	TOTAL SHEETS	SHEET NO.
64	(97-2) B-5	WHITE	578	106
CONTRACT NO. 78057				
ILLINOIS FED. AID PROJECT FAI 64/WABASH RIVER				

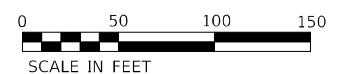
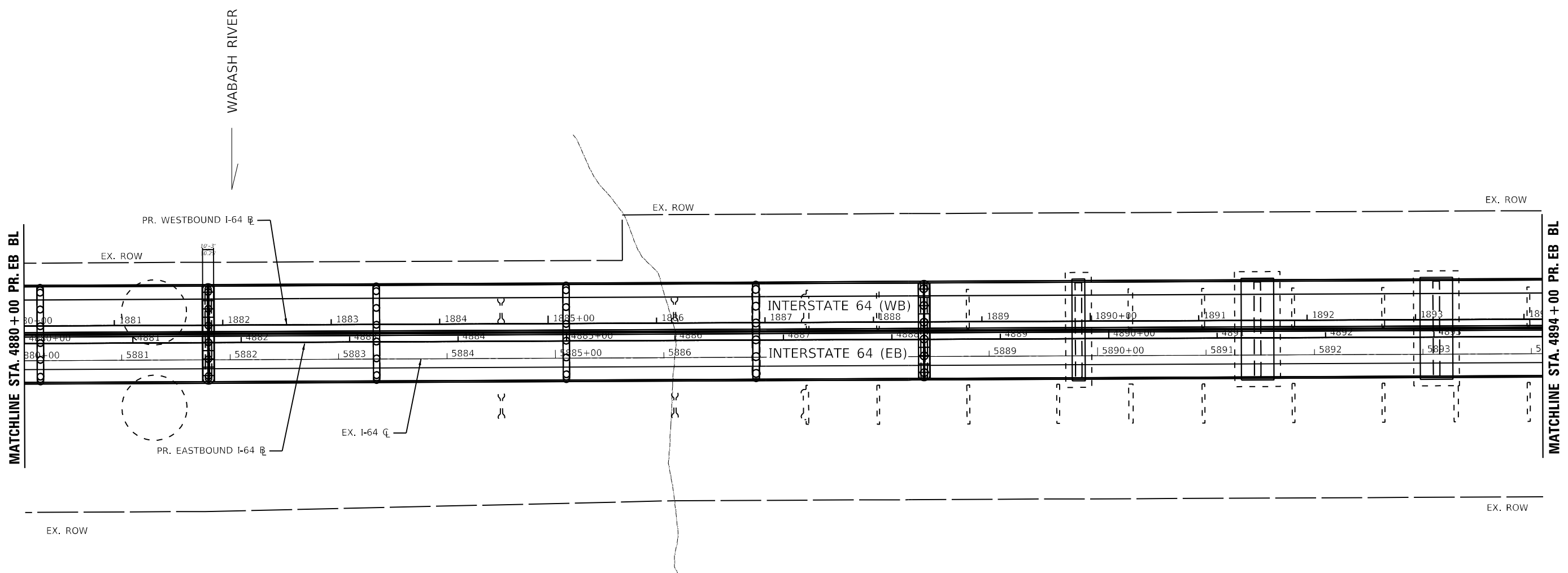

MODEL: I:\MODELS\NAME\ FILE: NAME: I:\2023\CAD\IS\vector\Plan_Profile\EB\0778057-sh-holnpr-400a.dwg



USER NAME = USWV706141	DESIGNED - JS	REVISED -
DRAWN - RTA	REVISIONS -	
PLOT SCALE = 1:100	CHECKED - JCM	REVISED -
PLOT DATE = 8/24/2023	DATE - 08/11/2023	REVISED -

**STATE OF ILLINOIS
DEPARTMENT OF TRANSPORTATION**

**ROADWAY PLAN AND PROFILE
EASTBOUND I-64**

SCALE: SHEET PP-5 OF 18 SHEETS STA. TO STA.

F.A.I. RTE.	SECTION	COUNTY	TOTAL SHEETS	SHEET NO.
64	(97-2) B-5	WHITE	578	107
CONTRACT NO. 78057				
ILLINOIS FED. AID PROJECT FAI 64/WABASH RIVER				

PLAN	STAVEYED	DATE
	PIOTTED	BY
NOTE BOOK NO.	ALIGNED CHECKED	
	CADD FILE NAME	

PROFILE	SURVEYED	DATE
	PIOTTED	BY
NOTE BOOK NO.	GRADES CHECKED	
	STRUCTURE NOTATIONS UPWD	

MODEL: S:\MODEL\NAMES
FILE NAME: E:\7660\CAD\1\Sheet\18 - Profile\811023\811023-400.dwg

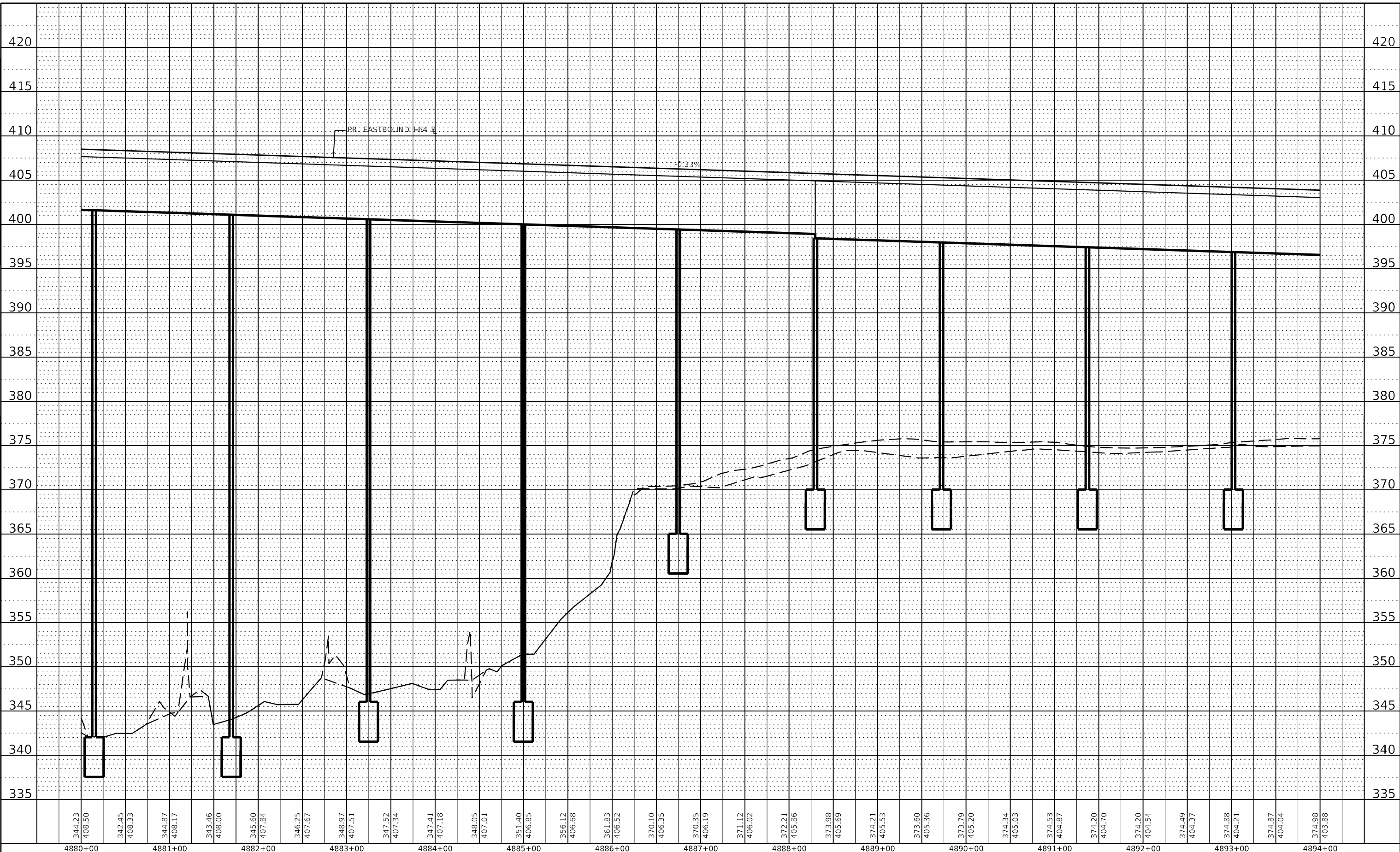

344.23	342.45	344.87	343.46	345.60	346.25	348.97	347.52	347.41	348.05	351.40	356.12	361.83	370.10	370.35	373.98	374.21	373.60	373.79	374.34	374.53	374.20	374.49	374.88	374.87	374.98	
408.50	408.33	408.17	408.00	407.84	407.67	407.51	407.34	407.18	407.01	406.85	406.68	406.52	406.35	406.19	405.69	405.53	405.36	405.20	405.03	404.87	404.70	404.54	404.37	404.21	404.04	403.88
4880+00	4881+00	4882+00	4883+00	4884+00	4885+00	4886+00	4887+00	4888+00	4889+00	4890+00	4891+00	4892+00	4893+00	4894+00												



USER NAME = USWV706141	DESIGNED - JS	REVISED -
PLOT SCALE = 1:100	DRAWN - RTA	REVISED -
PLOT DATE = 8/24/2023	CHECKED - JCM	REVISED -
	DATE - 08/11/2023	REVISED -

STATE OF ILLINOIS
DEPARTMENT OF TRANSPORTATION

ROADWAY PLAN AND PROFILE			
EASTBOUND I-64			
SCALE:	SHEET PP-6	OF 18 SHEETS	STA. TO STA.

F.A.I. RTE.	SECTION	COUNTY	TOTAL SHEETS	SHEET NO.
64	(97-2) B-5	WHITE	578	108
CONTRACT NO. 78057				
ILLINOIS FED. AID PROJECT FAI 64/AVBASH RIVER				

PLAN	SURVEYED	DATE
	PLOTTED	BY
	ALIGNED/CHECKED	
	CADD FILE NAME	
	NO.	

PROFILE	SURVEYED	DATE
	PLOTTED	BY
	GRADES CHECKED	
	STRUCTURE NOTATIONS CHECKED	
	NO.	

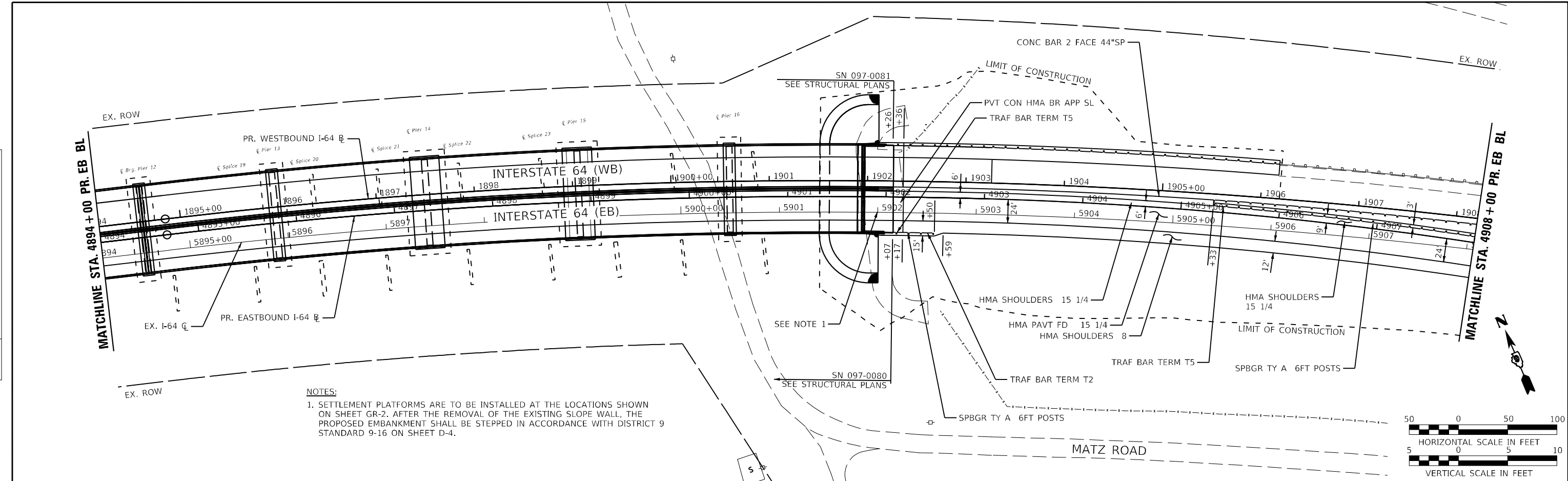

NOTES:
 1. SETTLEMENT PLATFORMS ARE TO BE INSTALLED AT THE LOCATIONS SHOWN ON SHEET GR-2. AFTER THE REMOVAL OF THE EXISTING SLOPE WALL, THE PROPOSED EMBANKMENT SHALL BE STEPPED IN ACCORDANCE WITH DISTRICT 9 STANDARD 9-16 ON SHEET D-4.

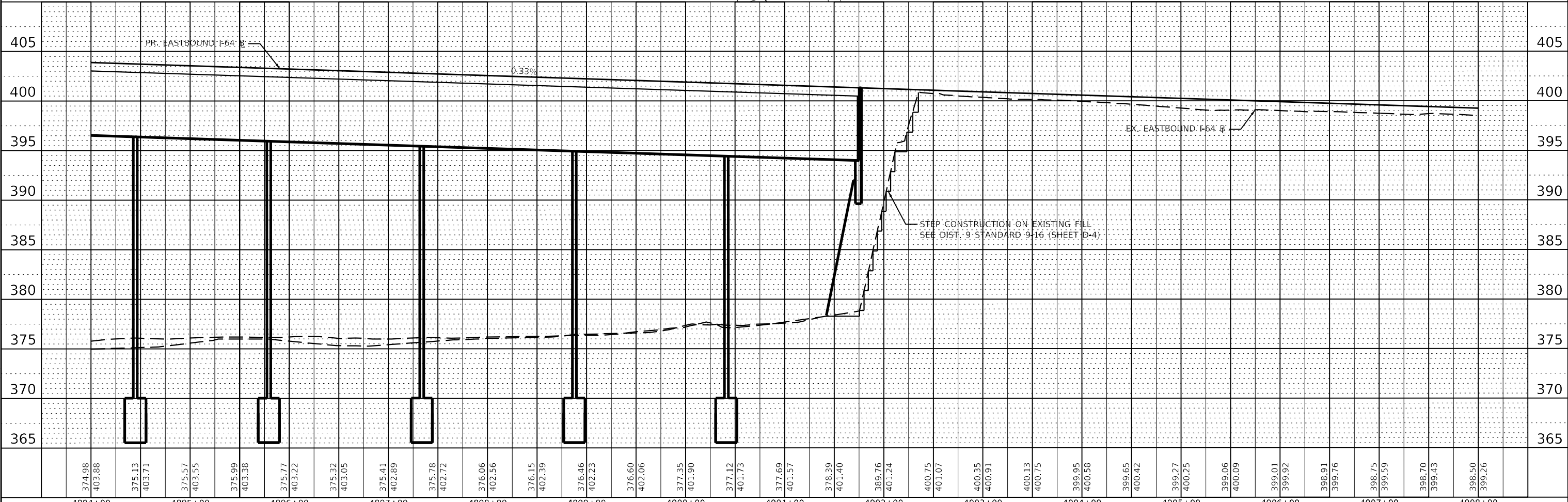
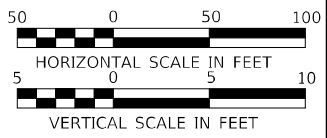

4894+00	4895+00	4896+00	4897+00	4898+00	4899+00	4900+00	4901+00	4902+00	4903+00	4904+00	4905+00	4906+00	4907+00	4908+00
374.98	375.57	375.77	375.41	376.06	376.15	377.35	377.69	378.39	389.76	400.13	399.65	399.27	398.75	398.50
403.88	403.55	403.22	402.89	402.56	402.39	401.90	401.57	401.40	400.91	400.75	400.42	400.09	399.92	399.26
375.13	375.99	375.77	375.41	376.06	376.15	377.35	377.69	378.39	389.76	400.13	399.65	399.27	398.75	398.50
403.71	403.38	403.22	402.89	402.56	402.39	401.90	401.57	401.40	400.91	400.75	400.42	400.09	399.92	399.26

KNIGHT
 Engineers & Architects

USER NAME = USJ5706126	DESIGNED - JS	REVISED -
PLOT SCALE = 1:100,033	DRAWN - RTA	REVISED -
PLOT DATE = 8/24/2023	CHECKED - JCM	REVISED -
	DATE - 08/11/2023	REVISED -

STATE OF ILLINOIS
 DEPARTMENT OF TRANSPORTATION

ROADWAY PLAN AND PROFILE		TOTAL SHEETS		SHEET NO.	
EASTBOUND I-64		578		109	
SCALE:	SHEET PP-7 OF 18 SHEETS	STA.	TO STA.		

F.A.I. RTE.	SECTION	COUNTY	CONTRACT NO.
64	(97-2) B-5	WHITE	78057
ILLINOIS FED. AID PROJECT FAI 64/WABASH RIVER			

MODEL: S:\MODEL\I64\I64_Plan_Profile.dwg

PLAN	SURVEYED	BY	DATE
	PLOTTED		
	ALIGNED		
	CHECKED		
	CADD FILE NAME		

PROFILE	SURVEYED	BY	DATE
	PLOTTED		
	GRADES CHECKED		
	STRUCTURE NOTATIONS		

MODEL: SPODELNAME\$
FILE NAME: E:\6601\CA01\Sheets\Pl-Profile\EB\972037-sh-hd-hmr-d06.dwg

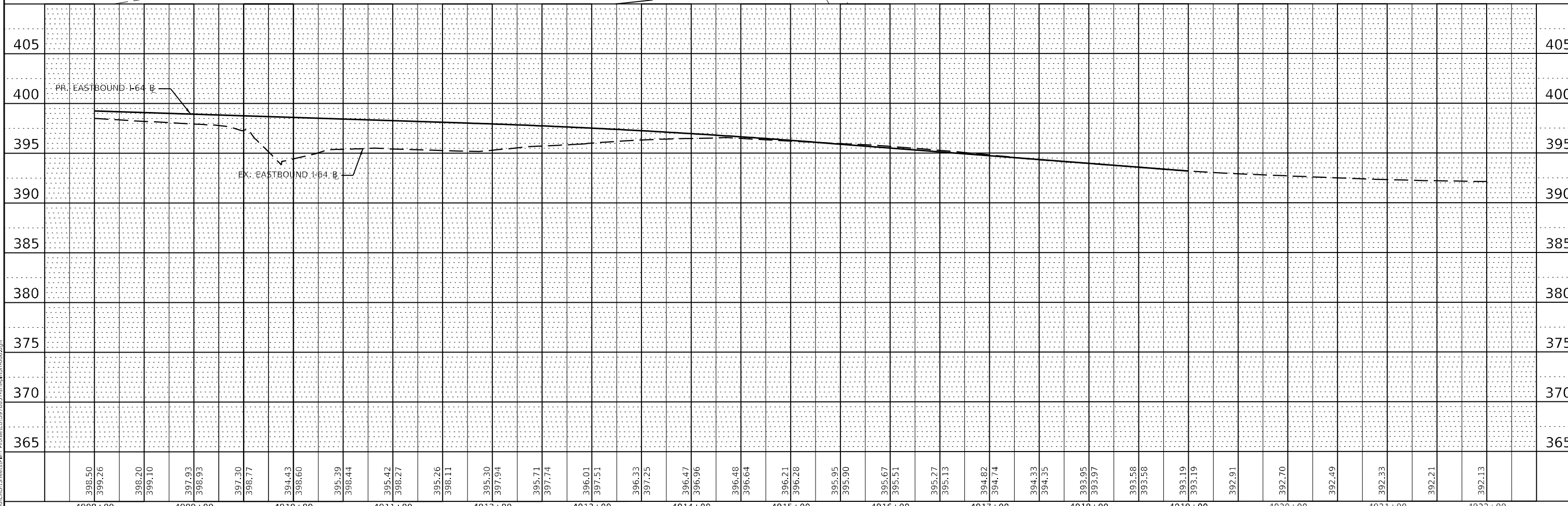
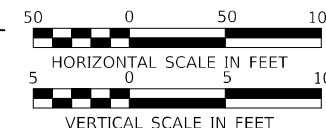
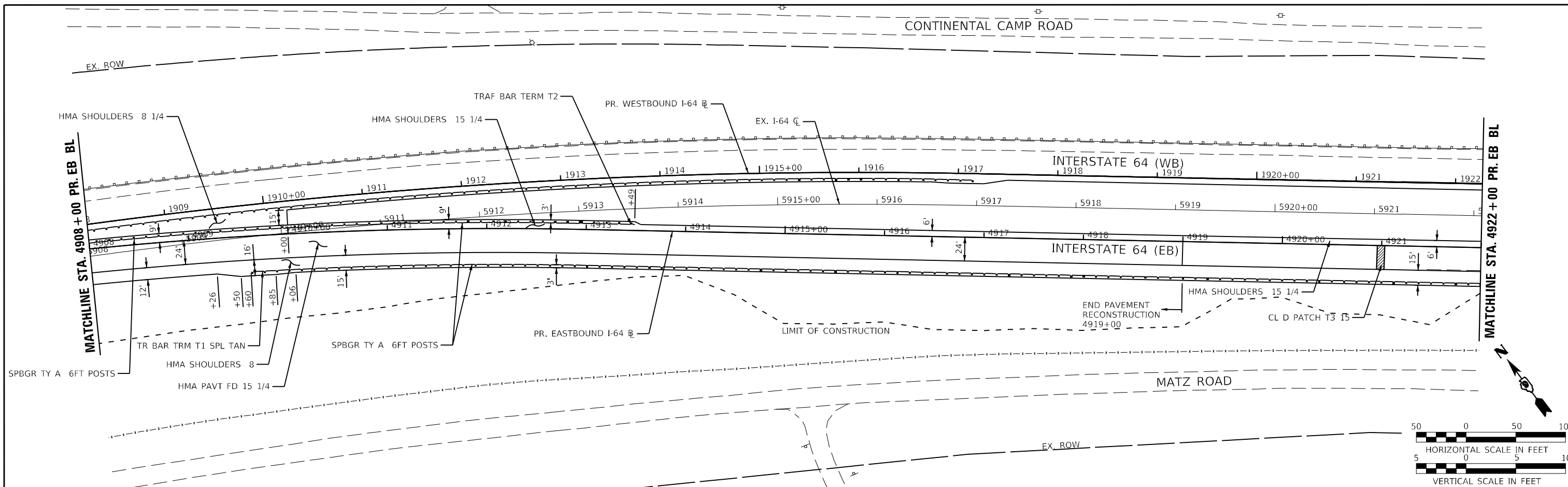

KNIGHT Engineers & Architects	USER NAME = USWV706141	DESIGNED - JS	REVISED -	STATE OF ILLINOIS DEPARTMENT OF TRANSPORTATION	ROADWAY PLAN AND PROFILE		F.A.I. RTE. = 64	SECTION = (97-2) B-5	COUNTY = WHITE	TOTAL SHEETS = 578	SHEET NO. = 110
	PLOT SCALE = 1:100,033	CHECKED - JCM	REVISED -		EASTBOUND I-64		CONTRACT NO. 78057		ILLINOIS FED. AID PROJECT FAI 64/WABASH RIVER		
	PLOT DATE = 8/24/2023	DATE = 08/11/2023	REVISED -		SCALE:	SHEET PP-8 OF 18 SHEETS	STA. TO STA.				

PLAN	SURVEYED	DATE
	PIOTTED	
	ALIGNED	
	CHECKED	
	AS	
	FILE NAME	
	NO.	

PROFILE	SURVEYED	DATE
	PIOTTED	
	GRADES	
	CHECKED	
	STRUCTURE	
	NOTATION	
	NO.	

MODEL: S:\MODEL\NAMES
FILE NAME: E:\PROJECTS\78057\WB\Profile\WB\975057-1-11-11-11.dwg

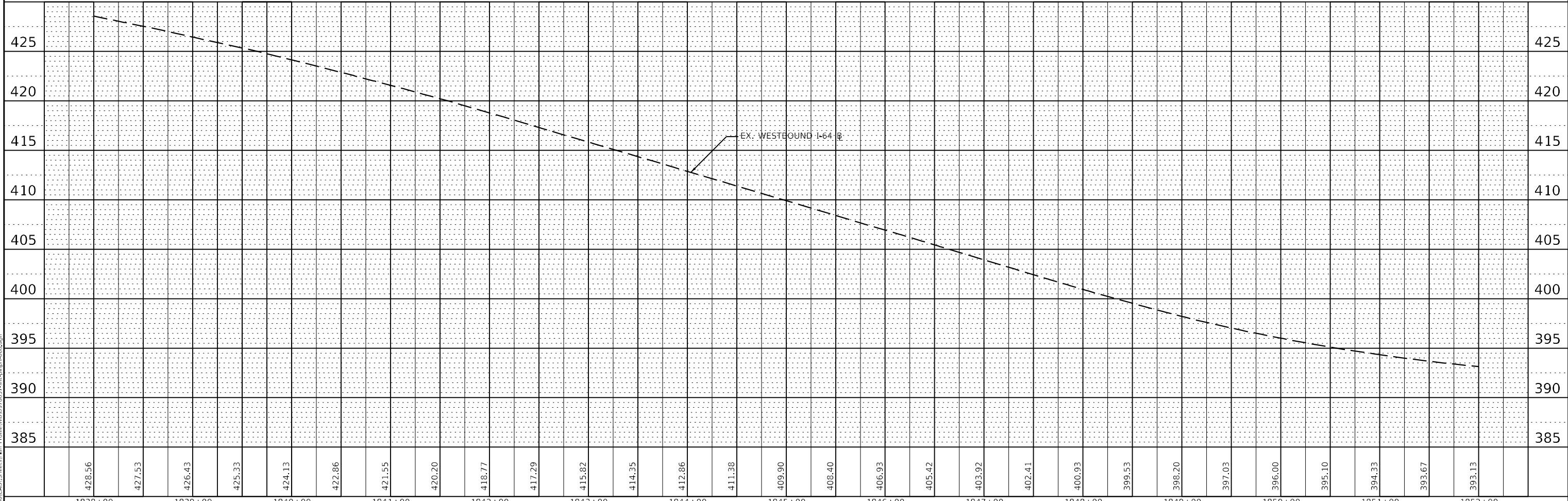
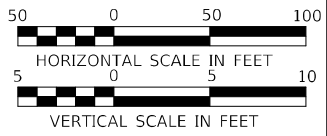
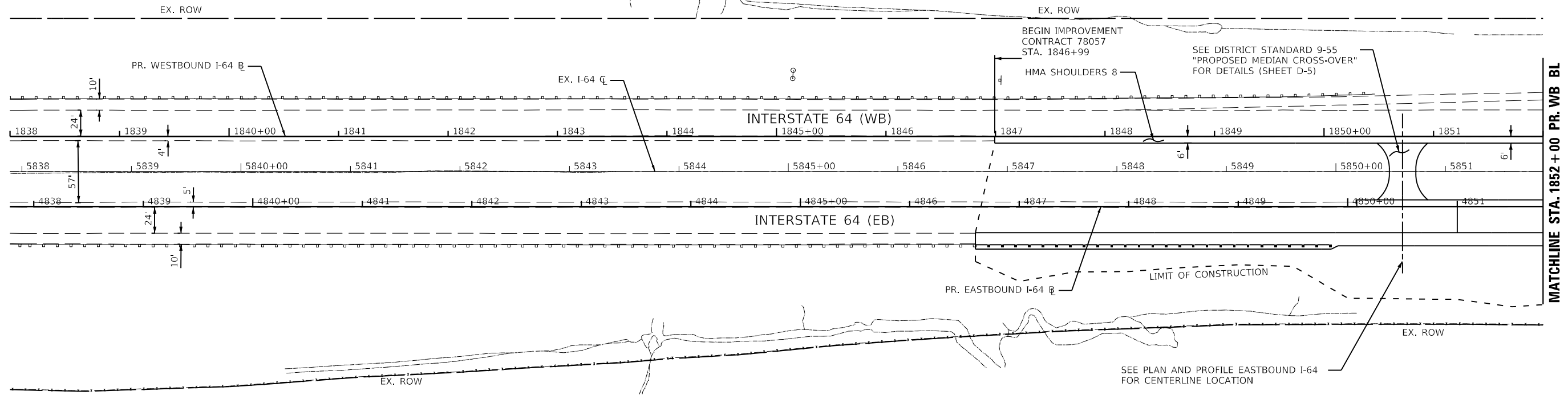

KNIGHT Engineers & Architects	USER NAME = USWV706141	DESIGNED - JS	REVISED -	STATE OF ILLINOIS DEPARTMENT OF TRANSPORTATION	ROADWAY PLAN AND PROFILE		F.A.I. RTE.	SECTION	COUNTY	TOTAL SHEETS	SHEET NO.
	PLOT SCALE = 1:100	DRAWN - RTA	REVISED -		64	(97-2) B-5	WHITE	578	112		
	PLOT DATE = 8/24/2023	CHECKED - JCM	REVISED -		CONTRACT NO. 78057						
		DATE - 08/11/2023	REVISED -		ILLINOIS FED. AID PROJECT FAI 64/WABASH RIVER						

SCALE: SHEET PP-10 OF 18 SHEETS STA. TO STA.

PLAN	DATE	BY
	NO.	
NOTE BOOK	NO.	
	NO.	
SURVEYED	DATE	BY
	NO.	
PLOTTED	DATE	BY
	NO.	
ALIGNED	DATE	BY
	NO.	
CHECKED	DATE	BY
	NO.	
CADD FILE NAME	NO.	
	NO.	

PROFILE	DATE	BY
	NO.	
SURVEYED	DATE	BY
	NO.	
PLOTTED	DATE	BY
	NO.	
GRADES CHECKED	DATE	BY
	NO.	
STRUCTURE NOTATION	DATE	BY
	NO.	

MODEL: S:\MODEL\NAMES
FILE NAME: E:\PROJECTS\I-64\WB\Profile\WB\975057-2-18-18\ppr000.dwg

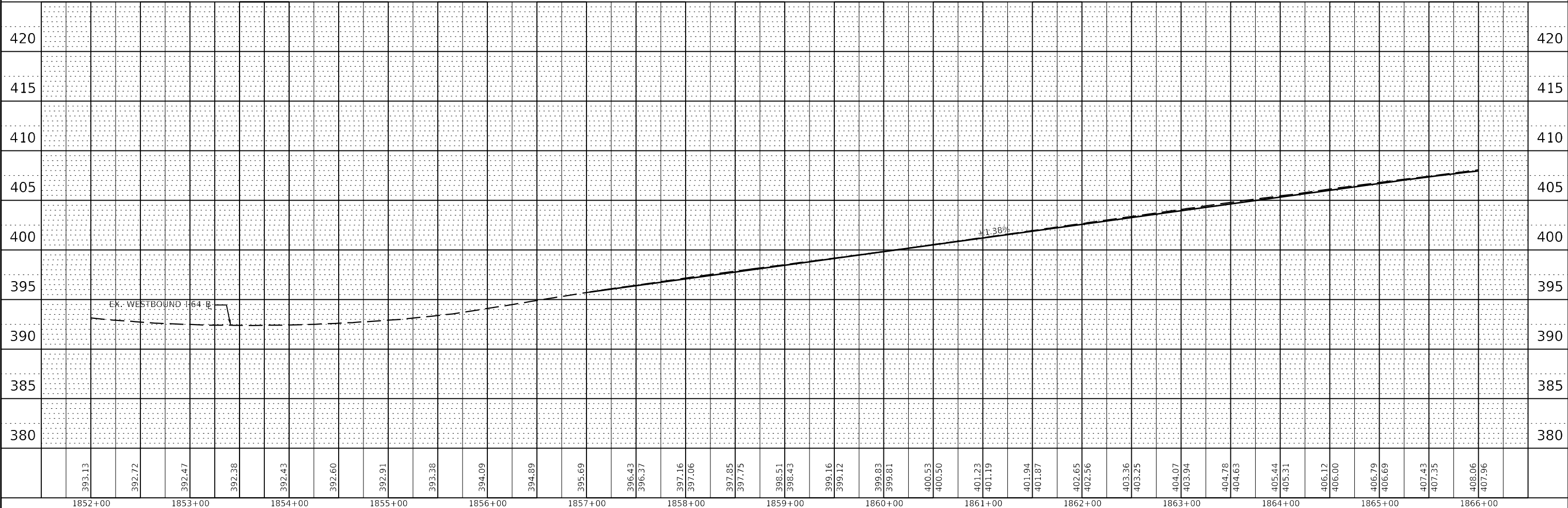
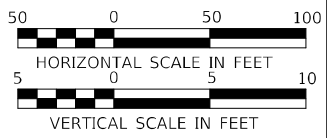
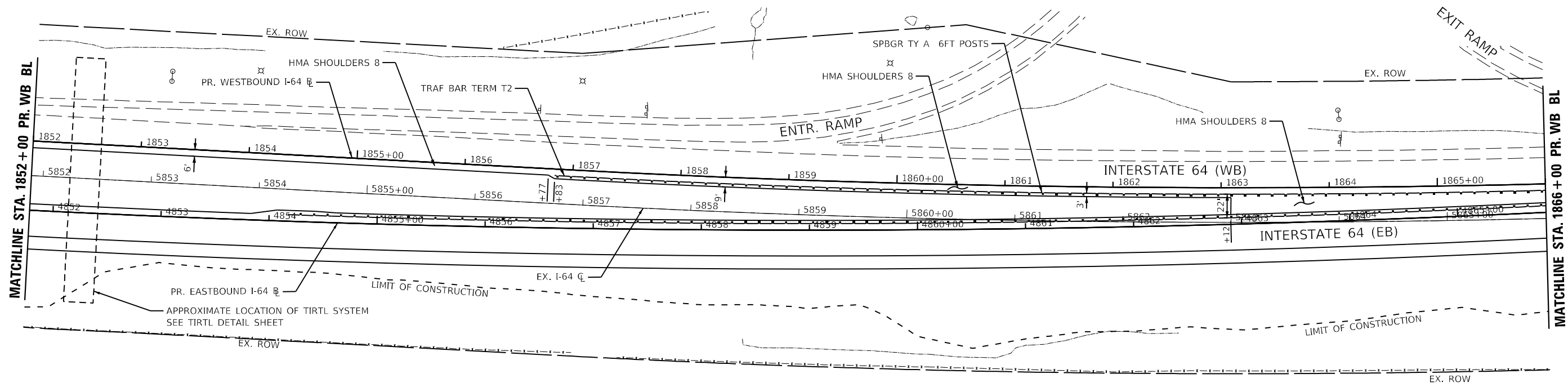

KNIGHT Engineers & Architects	USER NAME = USWV706141	DESIGNED - JS	REVISED -	STATE OF ILLINOIS DEPARTMENT OF TRANSPORTATION	ROADWAY PLAN AND PROFILE		F.A.I. RTE. = 64	SECTION = (97-2) B-5	COUNTY = WHITE	TOTAL SHEETS = 578	SHEET NO. = 113
	PLOT SCALE = 1:100	CHECKED - JCM	REVISED -		SCALE:	SHEET PP-11 OF 18 SHEETS	STA. TO STA.	CONTRACT NO. 78057			
PLOT DATE = 8/24/2023	DATE = 08/11/2023	REVISED -			ILLINOIS FED. AID PROJECT FAI 64/WABASH RIVER						

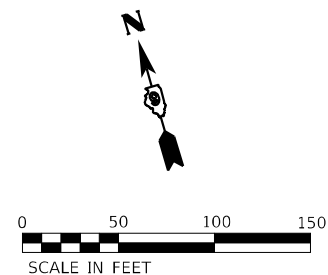
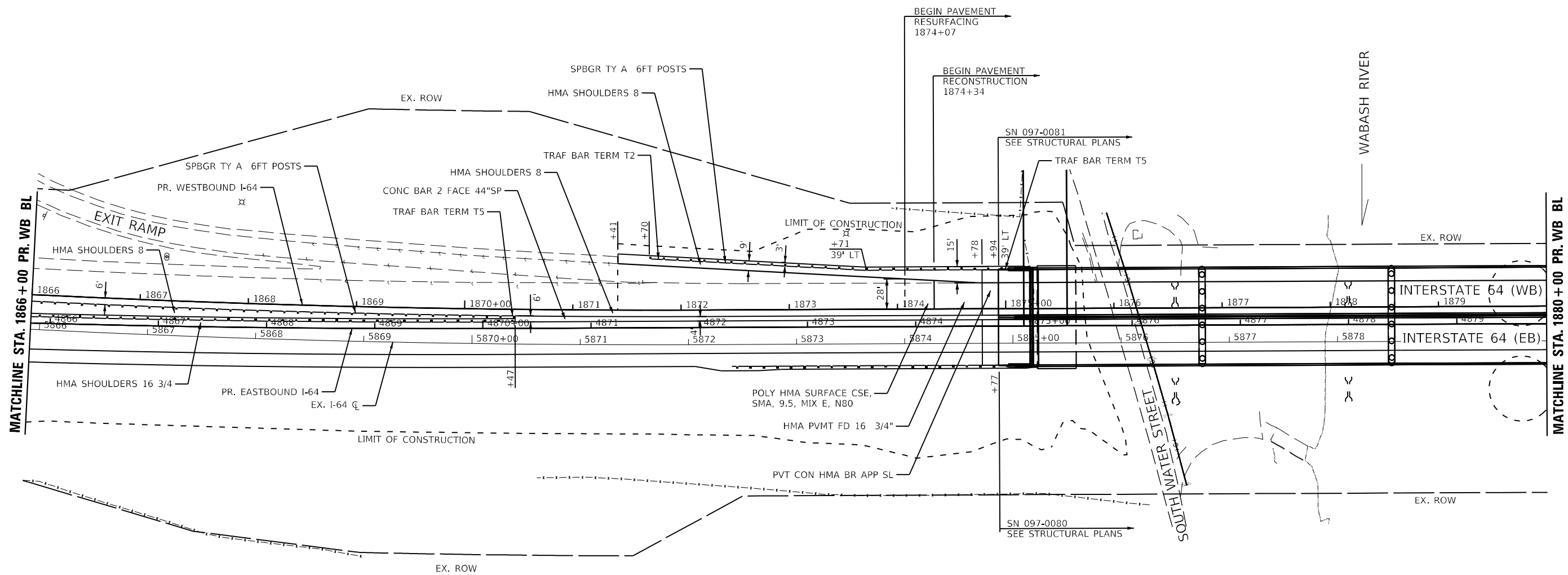

MODEL: I:\MODEL\NAME\...
 FILE NAME: I:\MODEL\I-64\WB\I-64WB\Profile\WB\I-64WB\Profile.dgn

KNIGHT
Engineers & Architects

USER NAME = USWV706141	DESIGNED - JS	REVISED -
PLOT SCALE = 1:100	DRAWN - RTA	REVISED -
PLOT DATE = 8/24/2023	CHECKED - JCM	REVISED -
	DATE - 08/11/2023	REVISED -

**STATE OF ILLINOIS
DEPARTMENT OF TRANSPORTATION**

ROADWAY PLAN AND PROFILE			
WESTBOUND I-64			
SCALE:	SHEET PP-12	OF 18 SHEETS	STA. TO STA.

F.A.I. RTE.	SECTION	COUNTY	TOTAL SHEETS	SHEET NO.
64	(97-2) B-5	WHITE	578	114
CONTRACT NO. 78057				
ILLINOIS FED. AID PROJECT FAI 64/WABASH RIVER				

PLAN	SURVEYED	DATE
NOTE BOOK	PLOTTED	BY
NO.	ALIGNMENT CHECKED	
	CADD FILE NAME	

PROFILE	SURVEYED	DATE
NOTE BOOK	PLOTTED	BY
NO.	GRADES CHECKED	
	STRUCTURE NOTATIONS UPWD	

MODEL: S:\MODEL\NAMES
FILE NAME: I:\7660\CAD\1\Sheets\Plan_Profile\WB03\8057-2-air-ppr-d10.dgn

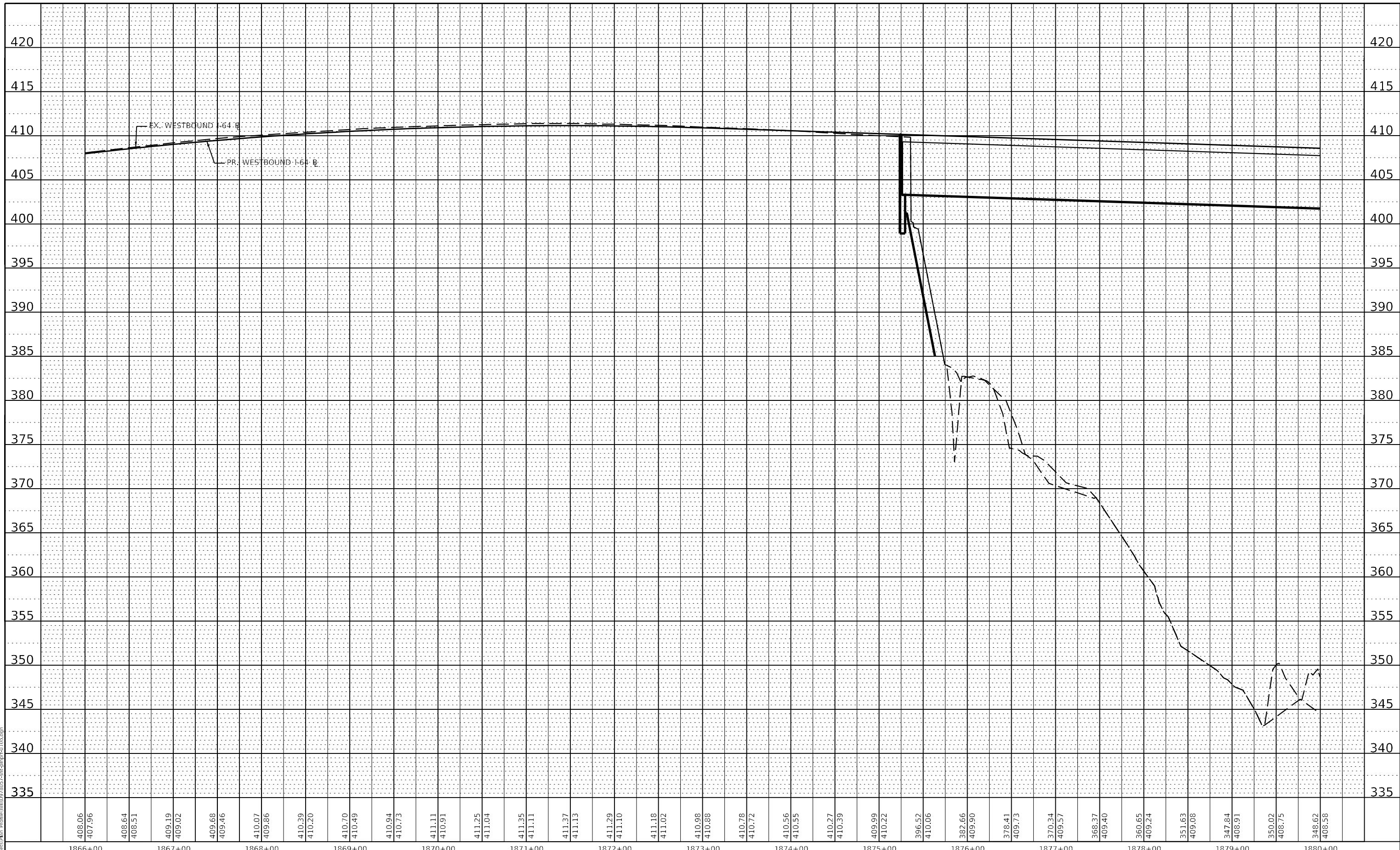

408.06	407.96	408.64	408.51	409.19	409.02	409.68	409.46	410.07	409.86	410.39	410.20	410.70	410.49	410.94	410.73	411.11	410.91	411.25	411.04	411.35	411.11	411.37	411.13	411.29	411.10	411.18	411.02	410.98	410.88	410.78	410.72	410.56	410.55	410.27	410.39	409.99	410.22	396.52	410.06	382.66	409.90	378.41	409.73	370.34	409.57	368.37	409.40	360.65	409.24	351.63	409.08	347.84	408.91	350.02	408.75	348.62	408.58
1866+00	1867+00	1868+00	1869+00	1870+00	1871+00	1872+00	1873+00	1874+00	1875+00	1876+00	1877+00	1878+00	1879+00	1880+00																																											



USER NAME = USWV706141	DESIGNED - JS	REVISED -
PLOT SCALE = 1:100.004	DRAWN - RTA	REVISED -
PLOT DATE = 8/24/2023	CHECKED - JCM	REVISED -
	DATE - 08/11/2023	REVISED -

**STATE OF ILLINOIS
DEPARTMENT OF TRANSPORTATION**

**ROADWAY PLAN AND PROFILE
WESTBOUND I-64**

SCALE: SHEET PP-13 OF 18 SHEETS STA. TO STA.

F.A.I. RTE.	SECTION	COUNTY	TOTAL SHEETS	SHEET NO.
64	(97-2) B-5	WHITE	578	115
CONTRACT NO. 78057				
ILLINOIS FED. AID PROJECT FAI 64/WABASH RIVER				

WABASH RIVER

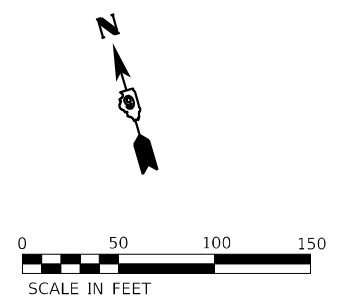
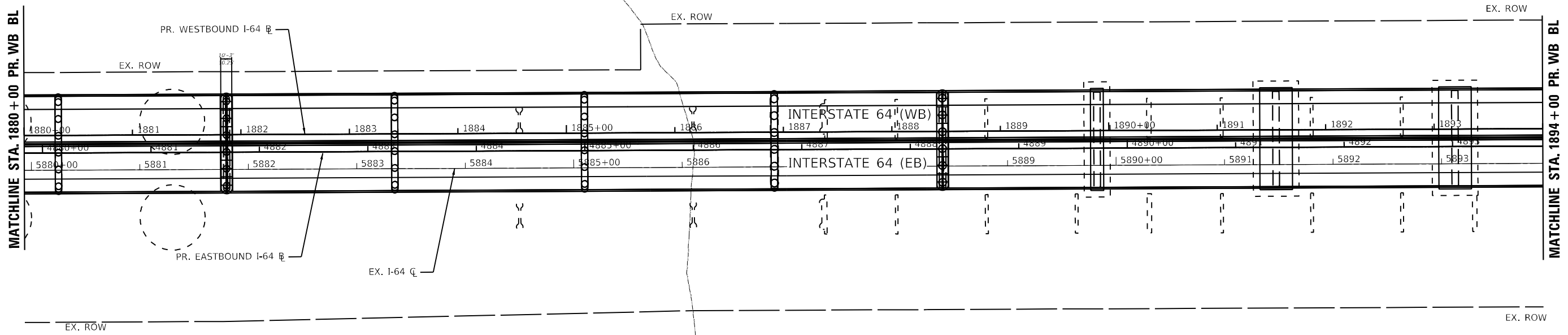

MODEL: 44001ENAMES
FILE: NAME: C:\2023\CAD\Projects\Bun_Profile\WB\I64\WB\I64WB.dgn

KNIGHT
Engineers & Architects

USER NAME = USWV706141	DESIGNED - JS	REVISED -
PLOT SCALE = 1:100	DRAWN - RTA	REVISED -
PLOT DATE = 8/24/2023	CHECKED - JCM	REVISED -
	DATE - 08/11/2023	REVISED -

**STATE OF ILLINOIS
DEPARTMENT OF TRANSPORTATION**

**ROADWAY PLAN AND PROFILE
WESTBOUND I-64**

SCALE: SHEET PP-14 OF 18 SHEETS STA. TO STA.

F.A.I. RTE.	SECTION	COUNTY	TOTAL SHEETS	SHEET NO.
64	(97-2) B-5	WHITE	578	116
CONTRACT NO. 78057				
ILLINOIS FED. AID PROJECT FAI 64/WABASH RIVER				

PLAN	SURVEYED	BY	DATE
	PLOTTED		
NOTE BOOK NO.	ALIGNMENT CHECKED		
	CADD FILE NAME		

PROFILE	SURVEYED	BY	DATE
	PLOTTED		
NOTE BOOK NO.	GRADES CHECKED		
	STRUCTURE NOTATION UPWD		

MODEL: S:\MODEL\NAMES
FILE NAME: E:\7660\CAD\1\Sheets\Plan_Profile\WB035052-2-in-11-plr.dwg

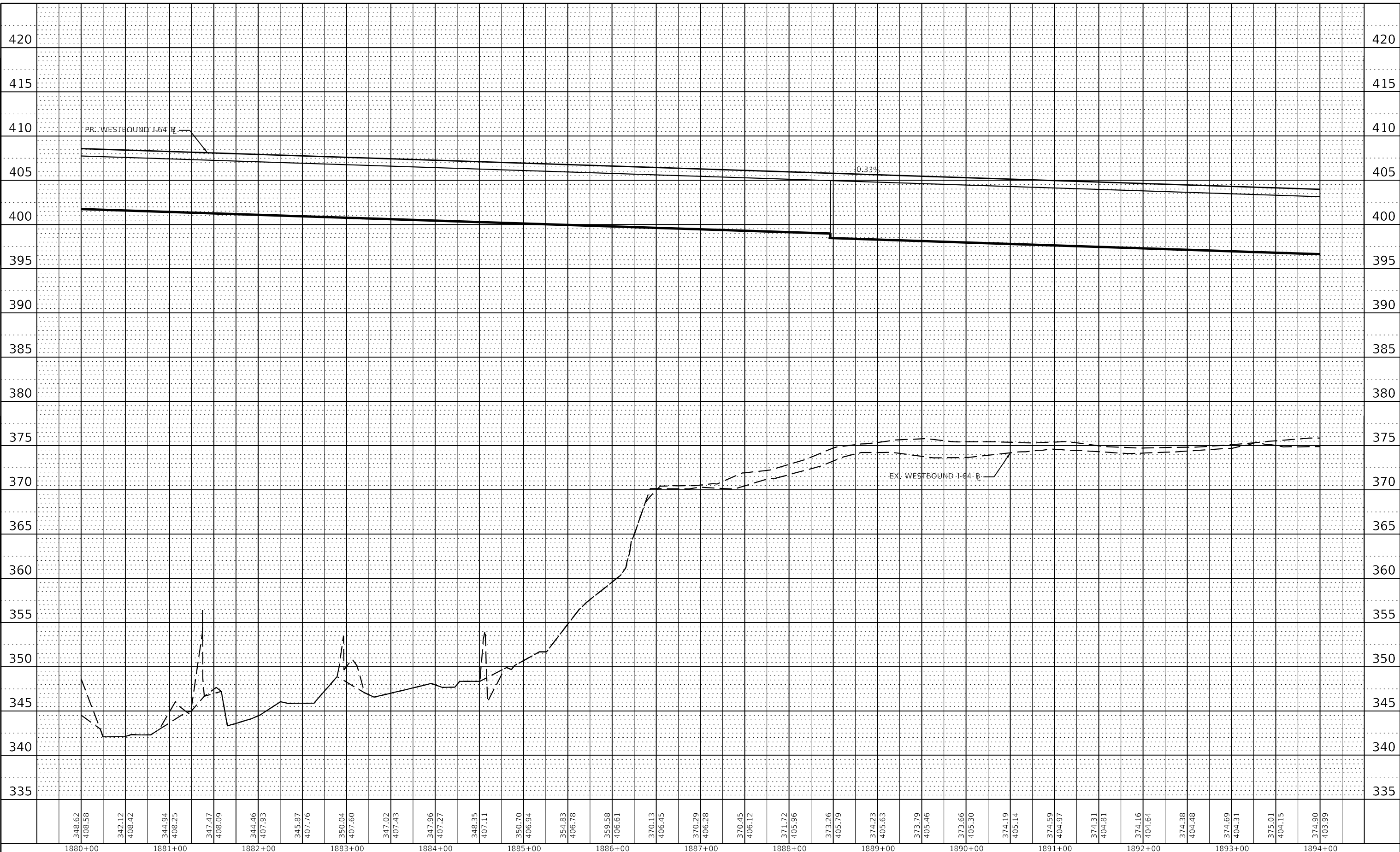

USER NAME = USWV706141	DESIGNED - JS	REVISED -
PLOT SCALE = 1:100.004	DRAWN - RTA	REVISED -
PLOT DATE = 8/24/2023	CHECKED - JCM	REVISED -
	DATE - 08/11/2023	REVISED -

**STATE OF ILLINOIS
DEPARTMENT OF TRANSPORTATION**

ROADWAY PLAN AND PROFILE		
WESTBOUND I-64		
SCALE:	SHEET PP-15 OF 18 SHEETS	STA. TO STA.

F.A.I. RTE. 64	SECTION (97-2) B-5	COUNTY WHITE	TOTAL SHEETS 578	SHEET NO. 117
CONTRACT NO. 78057				
ILLINOIS FED. AID PROJECT FAI 64/WABASH RIVER				

PLAN	SURVEYED	DATE
	PLOTTED	
	ALIGNED/CHECKED	
	CADD FILE NAME	
	NO.	

PROFILE	SURVEYED	DATE
	PLOTTED	
	GRADES CHECKED	
	STRUCTURE NOTATIONS CHECKED	
	NO.	

MODEL: S:\MODEL\I-64\WB\Profile\WB091907-211c-ppr01.dwg
 FILE NAME: E:\660\CADD\I-64\WB\Profile\WB091907-211c-ppr01.dwg

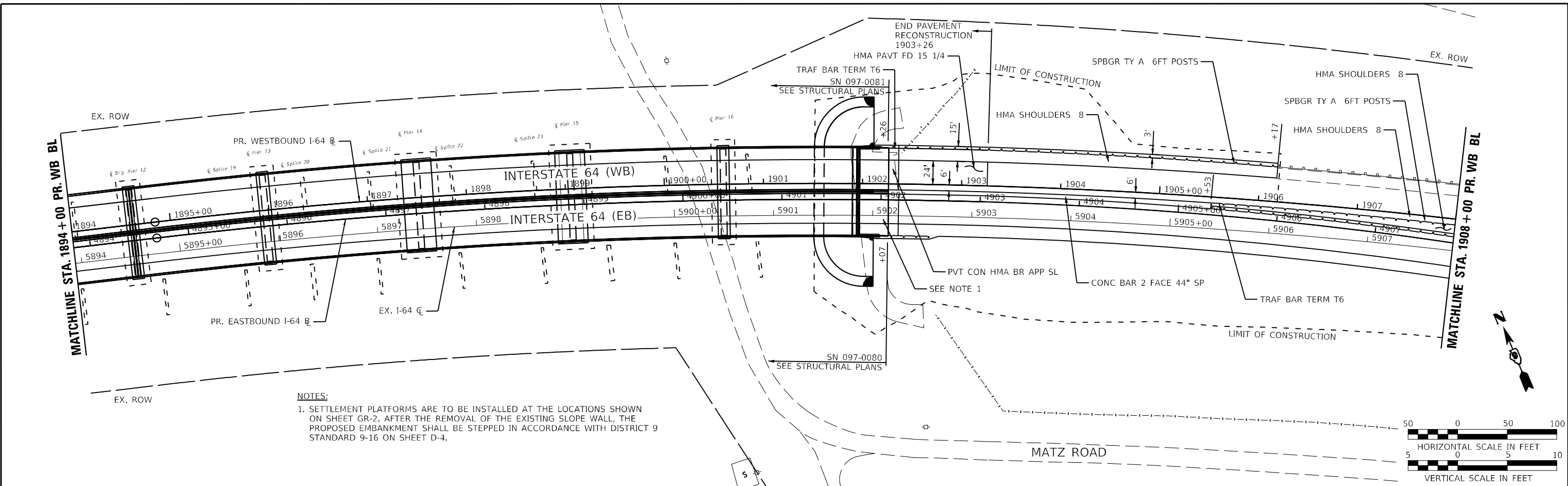

NOTES:
 1. SETTLEMENT PLATFORMS ARE TO BE INSTALLED AT THE LOCATIONS SHOWN ON SHEET GR-2. AFTER THE REMOVAL OF THE EXISTING SLOPE WALL, THE PROPOSED EMBANKMENT SHALL BE STEPPED IN ACCORDANCE WITH DISTRICT 9 STANDARD 9-16 ON SHEET D-4.

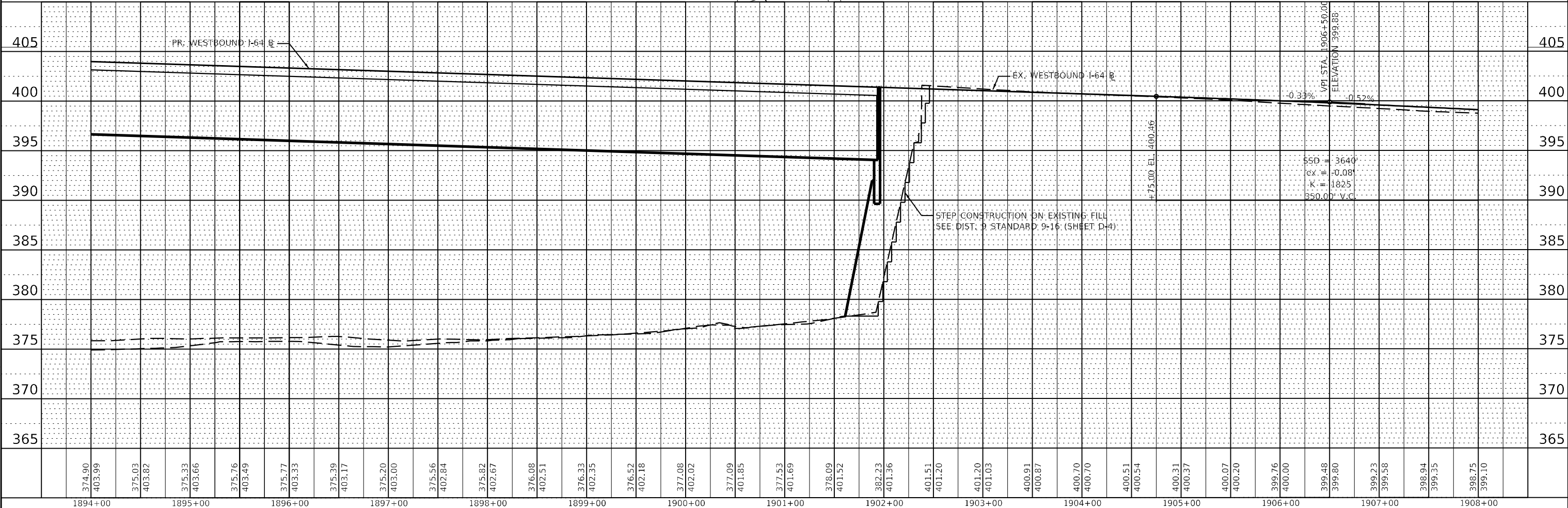
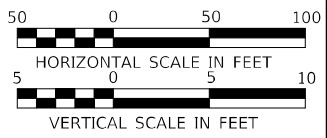

KNIGHT Engineers & Architects	USER NAME = USWV706141	DESIGNED - JS	REVISED -	STATE OF ILLINOIS DEPARTMENT OF TRANSPORTATION	ROADWAY PLAN AND PROFILE WESTBOUND I-64		F.A.I. R.T.E. = 64	SECTION = (97-2) B-5	COUNTY = WHITE	TOTAL SHEETS = 578	SHEET NO. = 118
	PLOT SCALE = 1:100,033	CHECKED - JCM	REVISED -		SCALE: SHEET PP-16 OF 18 SHEETS STA. TO STA.	CONTRACT NO. 78057 ILLINOIS FED. AID PROJECT FAI 64/WABASH RIVER					
	PLOT DATE = 8/24/2023	DATE = 08/11/2023	REVISED -								

PLAN	SURVEYED	DATE
	PLOTTED	BY
NOTE BOOK NO.	ALIGNED	
	CADD FILE NAME	

PROFILE	SURVEYED	DATE
	PLOTTED	BY
NOTE BOOK NO.	GRADES CHECKED	
	STRUCTURE NOTATIONS CHECKED	

MODEL: S:\MODEL\I-64\WB\Profile\WB091007-21-10-11-13.dwg
 FILE NAME: E:\660\CADD\I-64\WB\Profile\WB091007-21-10-11-13.dwg

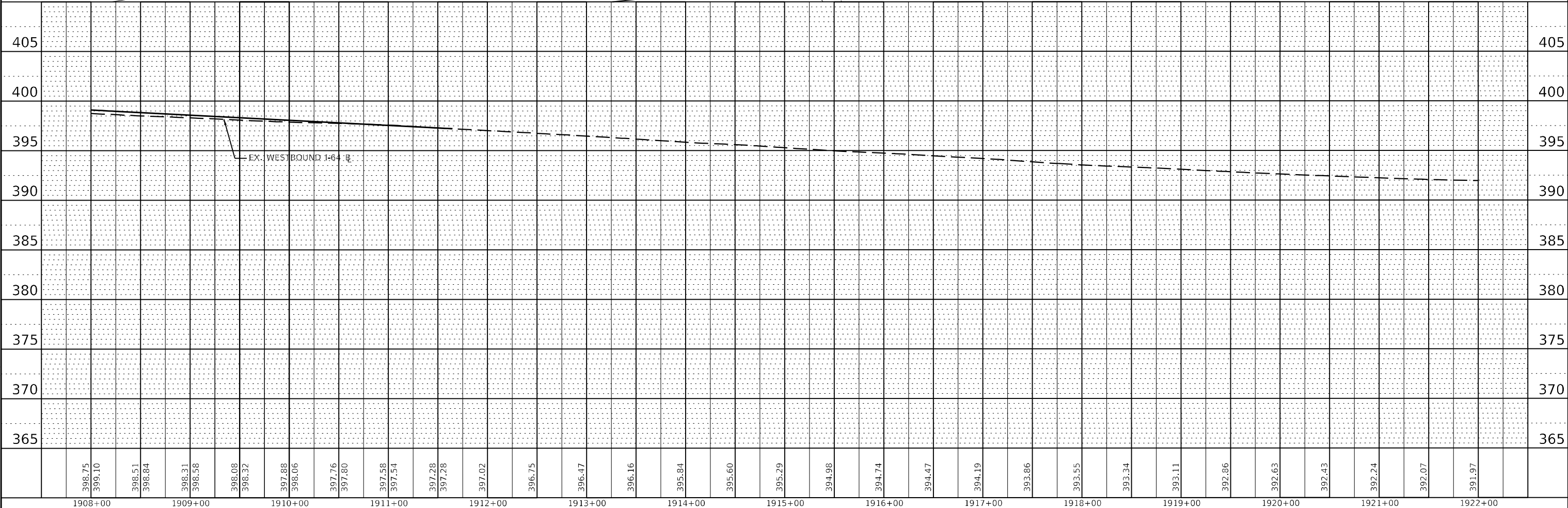
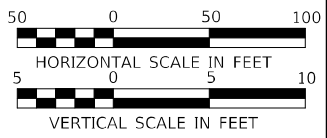
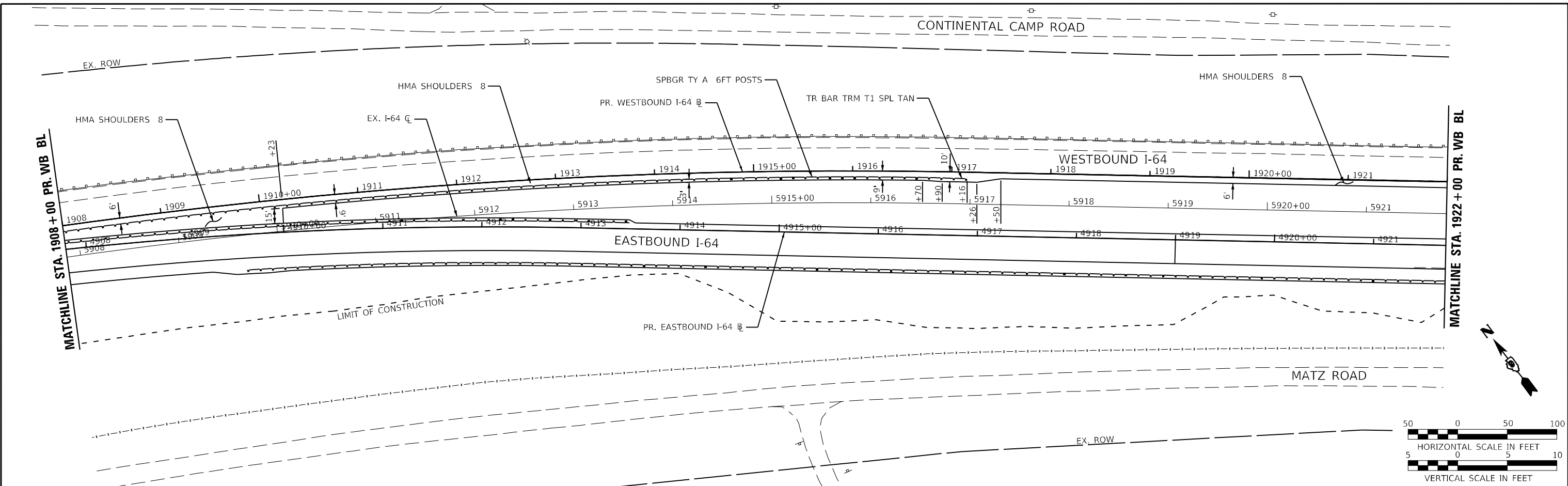

398.75	399.10	398.51	398.84	398.31	398.58	398.08	398.32	397.88	398.06	397.76	397.80	397.58	397.54	397.28	397.28	397.02	396.75	396.47	396.16	395.84	395.60	395.29	394.98	394.74	394.47	394.19	393.86	393.55	393.34	393.11	392.86	392.63	392.43	392.24	392.07	391.97			
1908+00	1909+00	1910+00	1911+00	1912+00	1913+00	1914+00	1915+00	1916+00	1917+00	1918+00	1919+00	1920+00	1921+00	1922+00																									

KNIGHT
Engineers & Architects

USER NAME = USWV706141	DESIGNED - JS	REVISED -
PLOT SCALE = 1:100,033	DRAWN - RTA	REVISED -
PLOT DATE = 8/24/2023	CHECKED - JCM	REVISED -
	DATE - 08/11/2023	REVISED -

**STATE OF ILLINOIS
DEPARTMENT OF TRANSPORTATION**

**ROADWAY PLAN AND PROFILE
WESTBOUND I-64**

SCALE: SHEET PP-17 OF 18 SHEETS STA. TO STA.

F.A.I. RTE. 64	SECTION (97-2) B-5	COUNTY WHITE	TOTAL SHEETS 578	SHEET NO. 119
CONTRACT NO. 78057				
ILLINOIS FED. AID PROJECT FAI 64/WABASH RIVER				

PLAN	DATE	BY
	NO.	
NOTE BOOK	NO.	
	NO.	
SURVEYED	DATE	BY
	NO.	
PLOTTED	DATE	BY
	NO.	
ALIGNED	DATE	BY
	NO.	
CHECKED	DATE	BY
	NO.	
CADD FILE NAME	NO.	
	NO.	

PROFILE	DATE	BY
	NO.	
SURVEYED	DATE	BY
	NO.	
PLOTTED	DATE	BY
	NO.	
GRADES CHECKED	DATE	BY
	NO.	
STRUCTURE NOTATION	DATE	BY
	NO.	

MODEL: S:\MODEL\NAMES
FILE NAME: E:\7600\CAD\1\Sheets\Matz Road\978057-4.dwg\p1p1-4.dwg

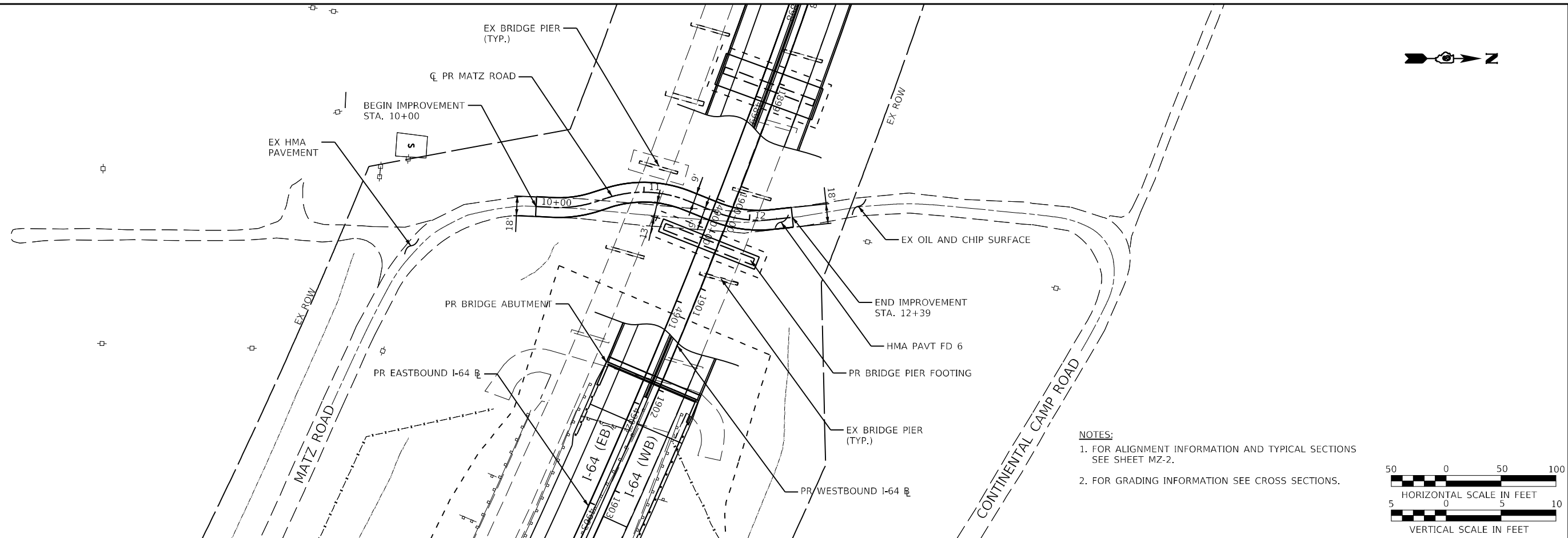

NOTES:
1. FOR ALIGNMENT INFORMATION AND TYPICAL SECTIONS SEE SHEET MZ-2.
2. FOR GRADING INFORMATION SEE CROSS SECTIONS.

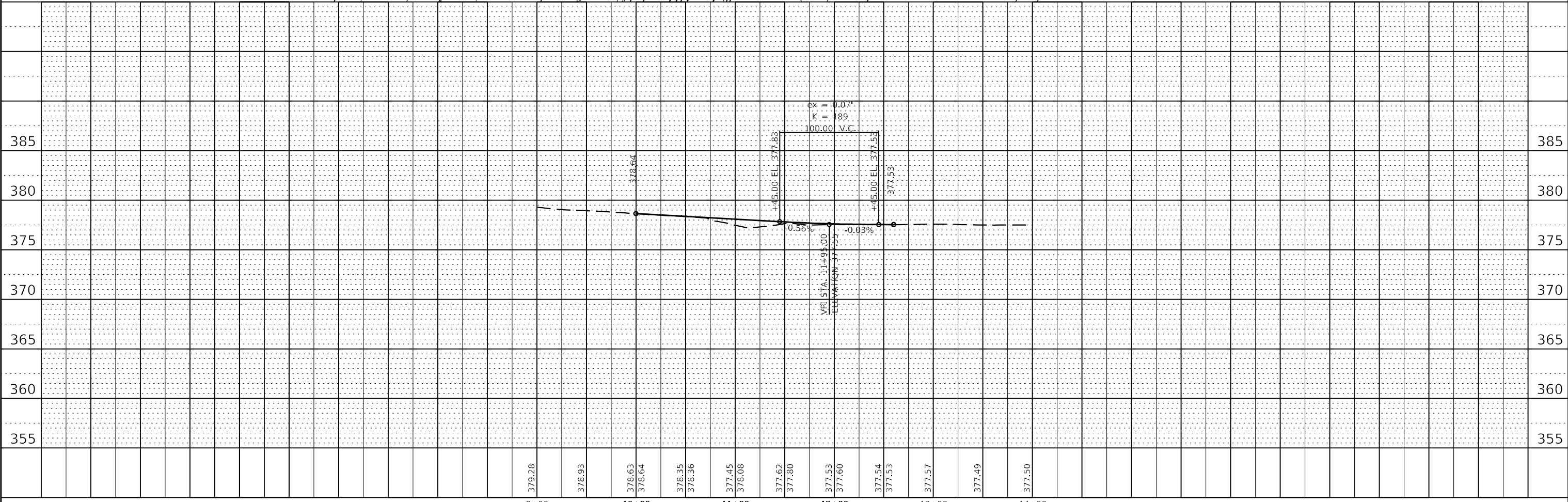
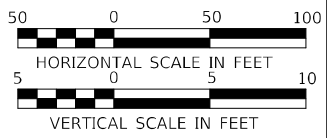

	USER NAME = USWV706141	DESIGNED - JS	REVISED -	STATE OF ILLINOIS DEPARTMENT OF TRANSPORTATION	ROADWAY PLAN AND PROFILE MATZ ROAD (INDIANA)		F.A.I. RTE.	SECTION	COUNTY	TOTAL SHEETS	SHEET NO.
	PLOT SCALE = 1:100	CHECKED - JCM	REVISED -		64	(97-2) B-5	WHITE	578	121	CONTRACT NO. 78057	
PLOT DATE = 8/10/2023	DATE - 08/11/2023	REVISED -		SCALE:	SHEET MR-1	OF 2 SHEETS	STA.	TO STA.	ILLINOIS FED. AID PROJECT FAI 64/WABASH RIVER		

COORDINATE DATA

POT 10	N=568254.62 E=1086124.09	PT 16	N=568392.40 E=1086118.69
PC 11	N=568270.49 E=1086124.86	PC 17	N=568417.83 E=1086128.89
PI 12	N=568290.31 E=1086125.84	PI 18	N=568442.51 E=1086138.78
PT 13	N=568309.16 E=1086119.64	PT 19	N=568468.96 E=1086135.97
PC 14	N=568319.15 E=1086116.35	POT 20	N=568488.19 E=1086133.93
PI 15	N=568356.20 E=1086104.17		

CURVE DATA

PROP. CURVE PR_MATZ_RD_1
 PI STA. = 10+35.73
 $\Delta = 21^\circ 00' 47''$ (LT)
 $D = 53^\circ 32' 51''$
 $R = 107.00'$
 $T = 19.84'$
 $L = 39.24'$
 $E = 1.82'$
 $e = \text{N.C.}$
 P.C. STA. = 10+15.88
 P.T. STA. = 10+55.12

CURVE DATA

PROP. CURVE PR_MATZ_RD_2
 PI STA. = 11+04.64
 $\Delta = 40^\circ 03' 05''$ (RT)
 $D = 53^\circ 32' 51''$
 $R = 107.00'$
 $T = 39.00'$
 $L = 74.80'$
 $E = 6.89'$
 $e = \text{N.C.}$
 P.C. STA. = 10+65.64
 P.T. STA. = 11+40.44

CURVE DATA

PROP. CURVE PR_MATZ_RD_3
 PI STA. = 11+94.43
 $\Delta = 27^\circ 54' 58''$ (LT)
 $D = 53^\circ 32' 51''$
 $R = 107.00'$
 $T = 26.59'$
 $L = 52.13'$
 $E = 3.26'$
 $e = \text{N.C.}$
 P.C. STA. = 11+67.84
 P.T. STA. = 12+19.97

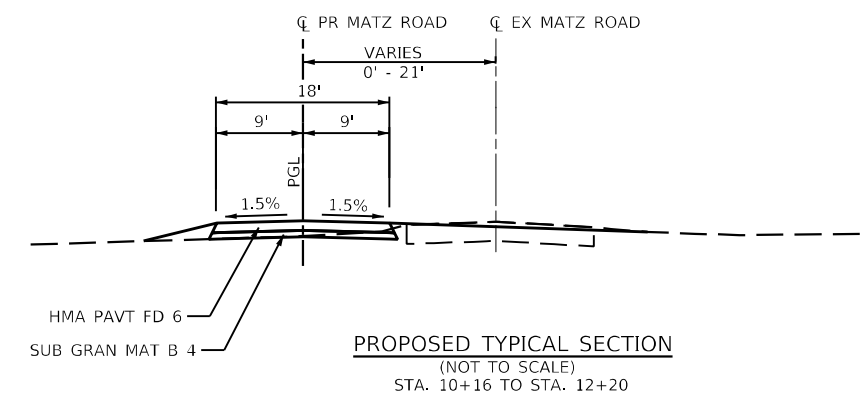
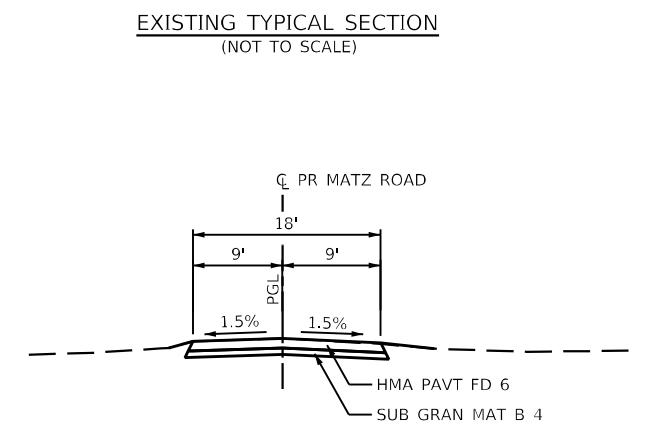
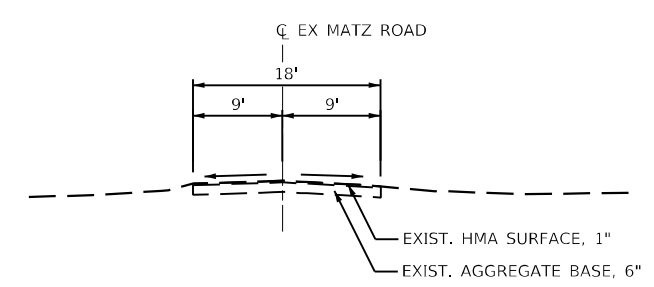
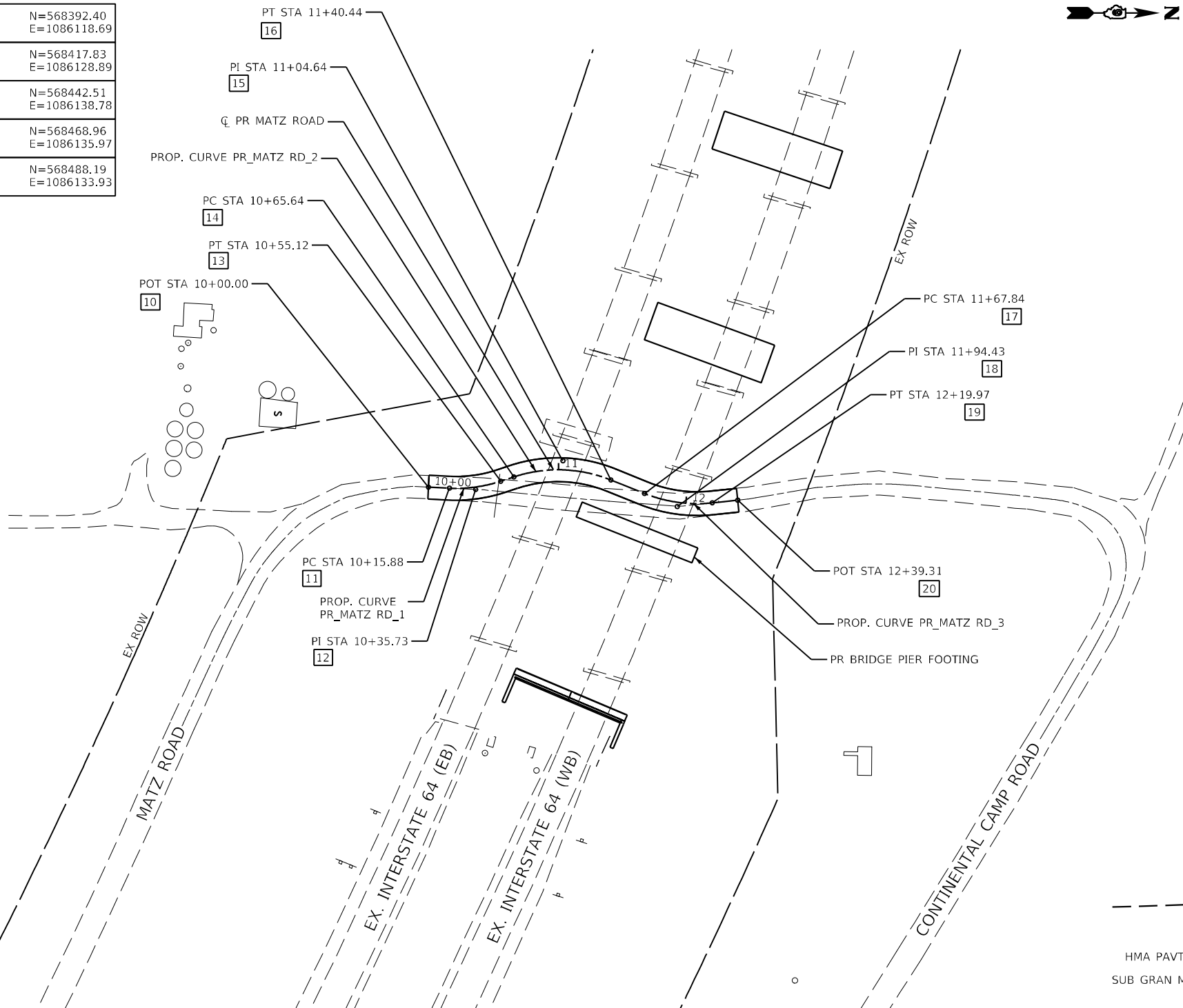

MODEL: I:\MODEL\NAME: FILE: NAME: I:\PROJECT\CD\US\Projects\Matz_Road\072023\h-ATB-Matz-Rd.dwg



USER NAME = USRA706046	DESIGNED - JS	REVISED -
	DRAWN - RTA	REVISED -
PLOT SCALE = 1:100.004	CHECKED - JCM	REVISED -
PLOT DATE = 8/24/2023	DATE - 08/11/2023	REVISED -

STATE OF ILLINOIS
DEPARTMENT OF TRANSPORTATION

ALIGNMENT, AND TYPICAL SECTIONS
MATZ ROAD

SCALE: SHEET MR-2 OF 2 SHEETS STA. TO STA.

F.A.I. RTE.	SECTION	COUNTY	TOTAL SHEETS	SHEET NO.
64	(97-2) B-5	WHITE	578	122
CONTRACT NO. 78057				
ILLINOIS FED. AID PROJECT FAI 64/WABASH RIVER				

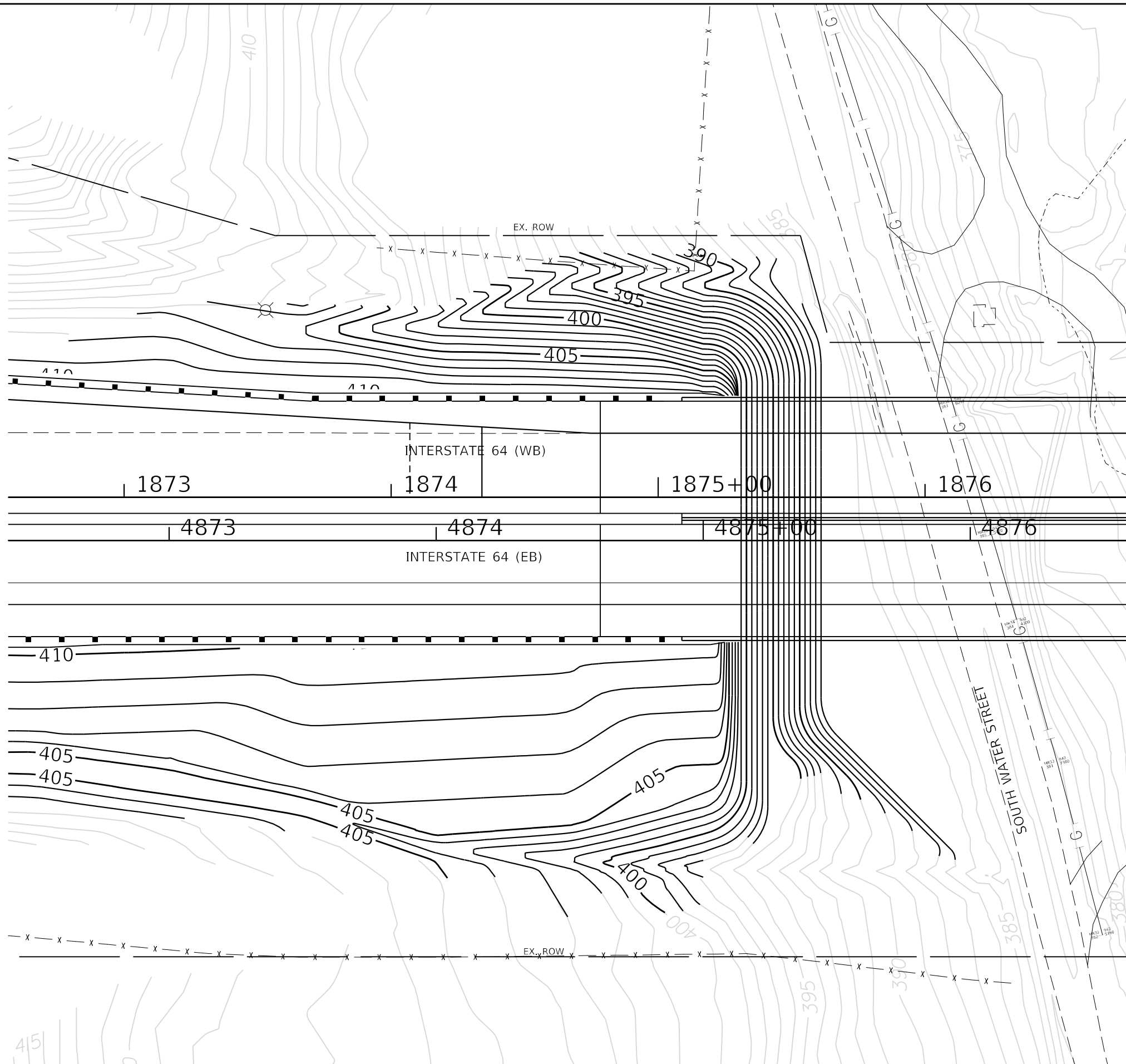

MODEL: I:\MODEL\NAME
 FILE: NAME: I:\78057\CAD\ISheets\Grading\078057-eh-gradplan-1.dgn

KNIGHT
 Engineers & Architects

USER NAME = USRA706046
PLOT SCALE = 1:40
PLOT DATE = 8/23/2023

DESIGNED - JS	REVISD -
DRAWN - RTA	REVISD -
CHECKED - JCM	REVISD -
DATE - 08/11/2023	REVISD -

STATE OF ILLINOIS
DEPARTMENT OF TRANSPORTATION

PROPOSED GRADING PLANS
I-64
 SCALE: SHEET GR-1 OF 3 SHEETS STA. TO STA.

F.A.I. RTE.	SECTION	COUNTY	TOTAL SHEETS	SHEET NO.
64	(97-2) B-5	WHITE	578	123
CONTRACT NO. 78057				
ILLINOIS FED. AID PROJECT FAI 64/WABASH RIVER				

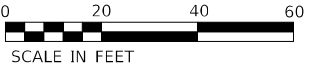
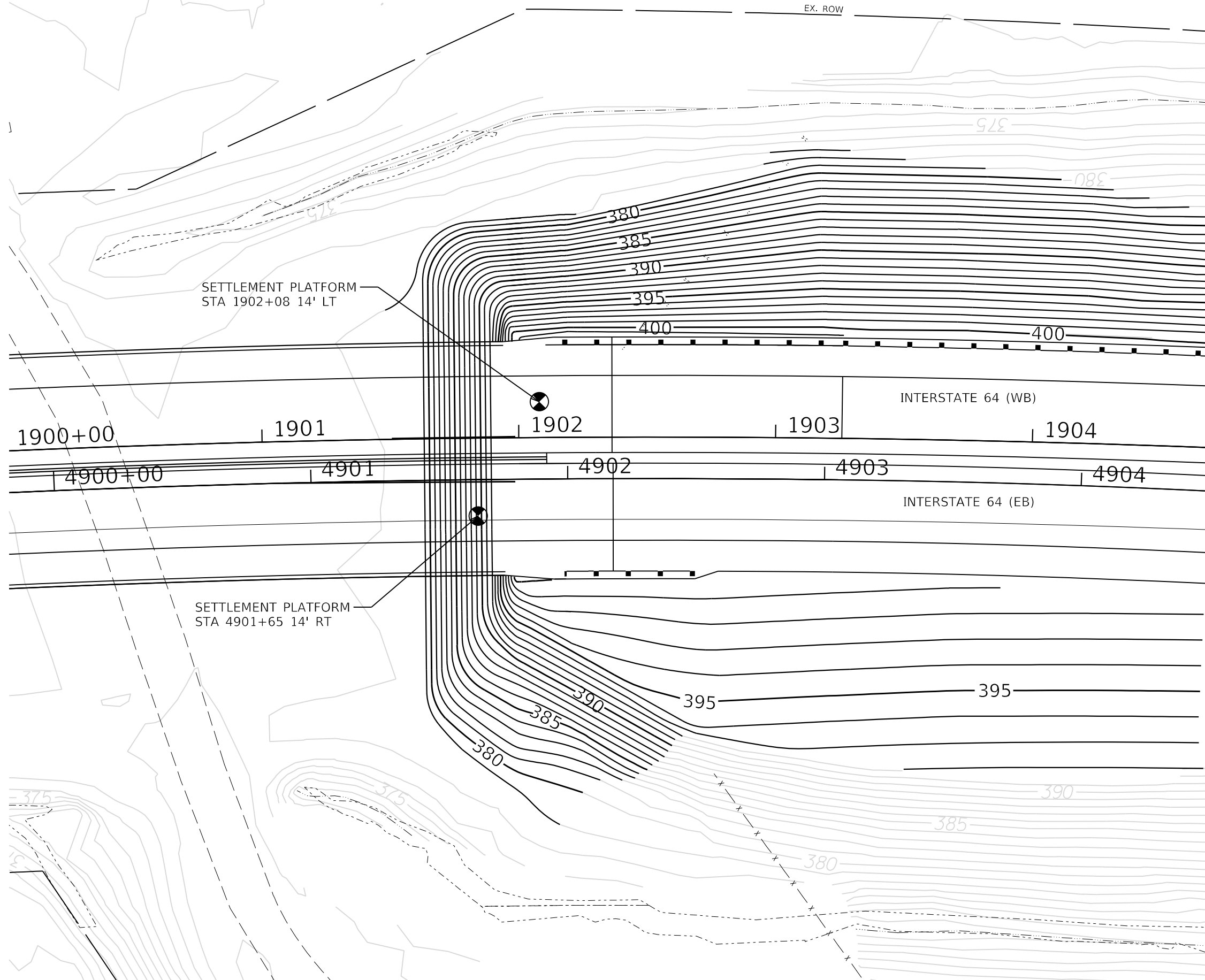

MODEL: I:\MODEL\NAME
 FILE NAME: I:\2023\CAD\Projects\Grading\078057-eh-gradimg2.dgn

KNIGHT
Engineers & Architects

USER NAME = USWV706141	DESIGNED - JS	REVISED -
PLOT SCALE = 1:40	DRAWN - RTA	REVISED -
PLOT DATE = 8/10/2023	CHECKED - JCM	REVISED -
	DATE - 08/11/2023	REVISED -

**STATE OF ILLINOIS
DEPARTMENT OF TRANSPORTATION**

**PROPOSED GRADING PLANS
I-64**

SCALE: SHEET GR-2 OF 3 SHEETS STA. TO STA.

F.A.I. RTE.	SECTION	COUNTY	TOTAL SHEETS	SHEET NO.
64	(97-2) B-5	WHITE	578	124
CONTRACT NO. 78057				
ILLINOIS FED. AID PROJECT FAI 64/WABASH RIVER				

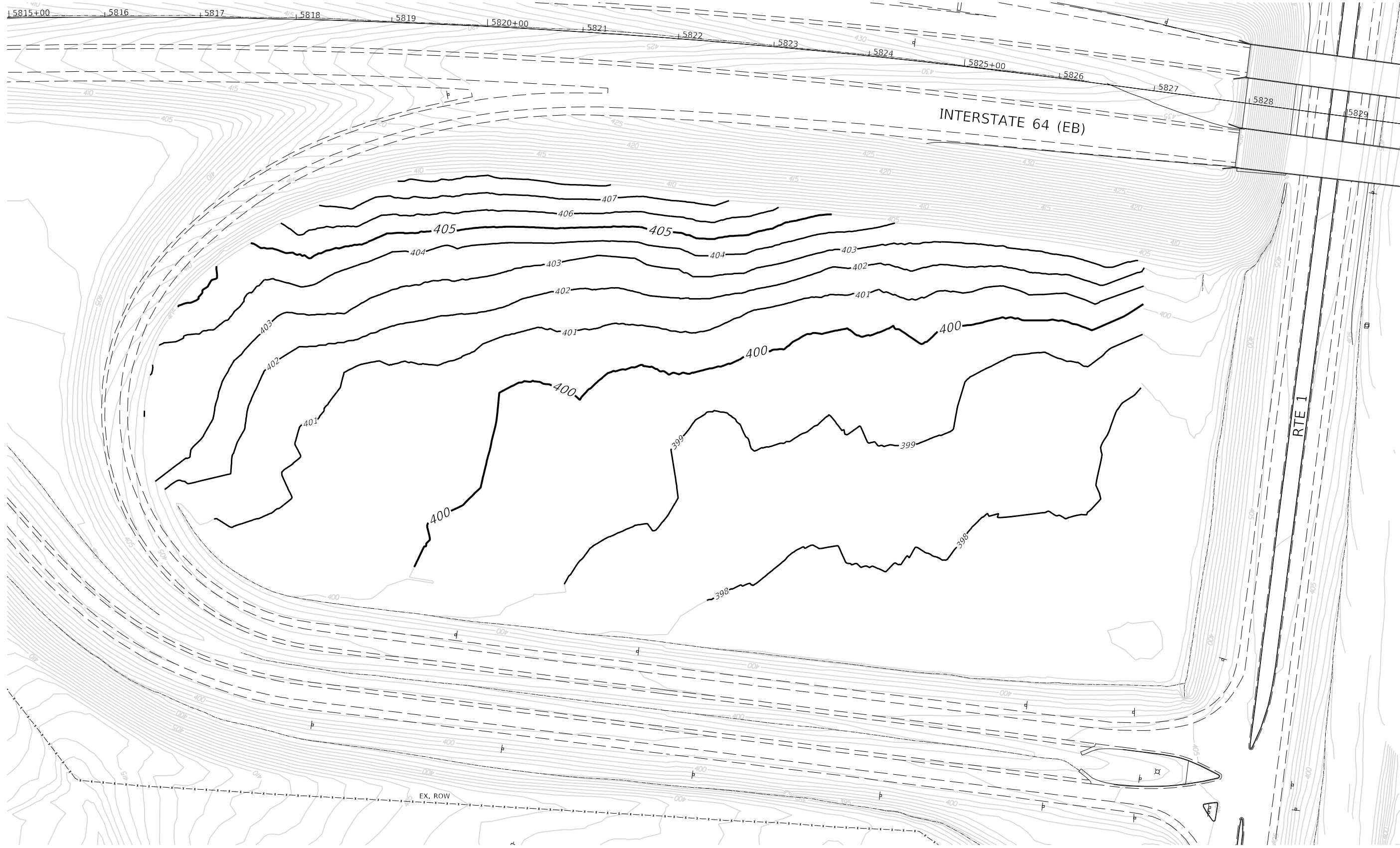

NOTES:
 1. SEE EROSION CONTROL EROSION AND SEDIMENT CONTROL MEASURES.

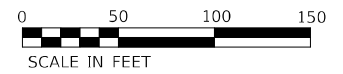

MODEL: 440021.NAMES
 FILE NAME: L:\2600\CAD\Projects\Grading\078507-eh\gradimg3.dwg

KNIGHT
 Engineers & Architects

USER NAME = USRA706046
 PLOT SCALE = 1:100
 PLOT DATE = 8/24/2023

DESIGNED - JS
 DRAWN - RTA
 CHECKED - JCM
 DATE - 08/11/2023

REVISED -
 REVISED -
 REVISED -
 REVISED -

**STATE OF ILLINOIS
 DEPARTMENT OF TRANSPORTATION**

**PROPOSED GRADING PLANS
 I-64**

SCALE: SHEET GR-3 OF 3 SHEETS STA. TO STA.

F.A.I. RTE.	SECTION	COUNTY	TOTAL SHEETS	SHEET NO.
64	(97-2) B-5	WHITE	578	125
CONTRACT NO. 78057				
ILLINOIS FED. AID PROJECT FAI 64/WABASH RIVER				

PLAN	SURVEYED	DATE
	PIOTTED	BY
	ALIGNED	
	CHECKED	
	CADD FILE NAME	
	NO.	

PROFILE	SURVEYED	DATE
	PIOTTED	BY
	GRADES CHECKED	
	STRUCTURE NOTATION	
	NO.	

MODEL: S:\MODEL\NAMES
FILE NAME: E:\960\CAD\1\Sheet\Drawings\97857-241\sewerplan-001.dgn

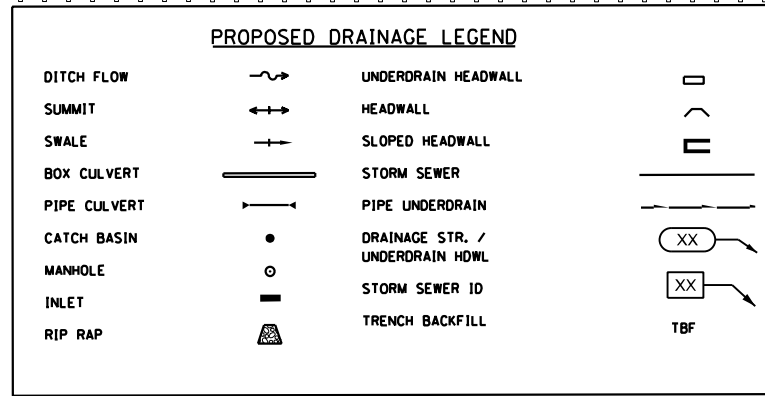
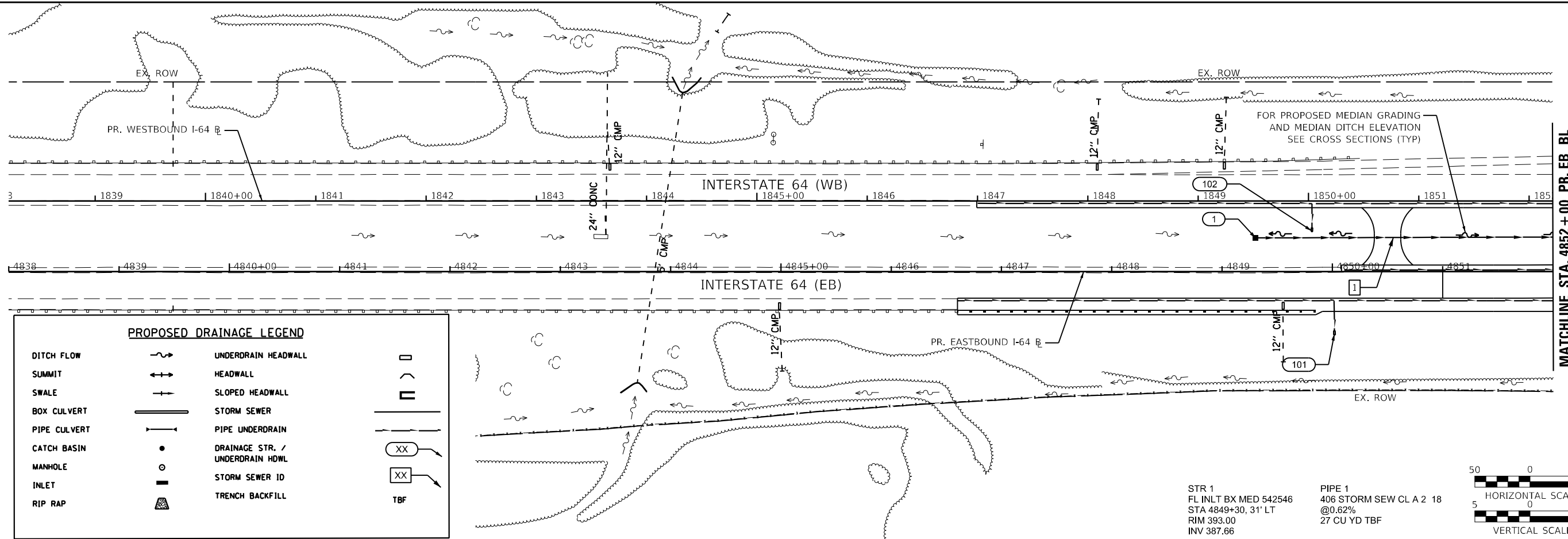

STR 1
FL INLT BX MED 542546
STA 4849+30, 31' LT
RIM 393.00
INV 387.66

PIPE 1
406 STORM SEW CL A 2 18
@0.62%
27 CU YD TBF

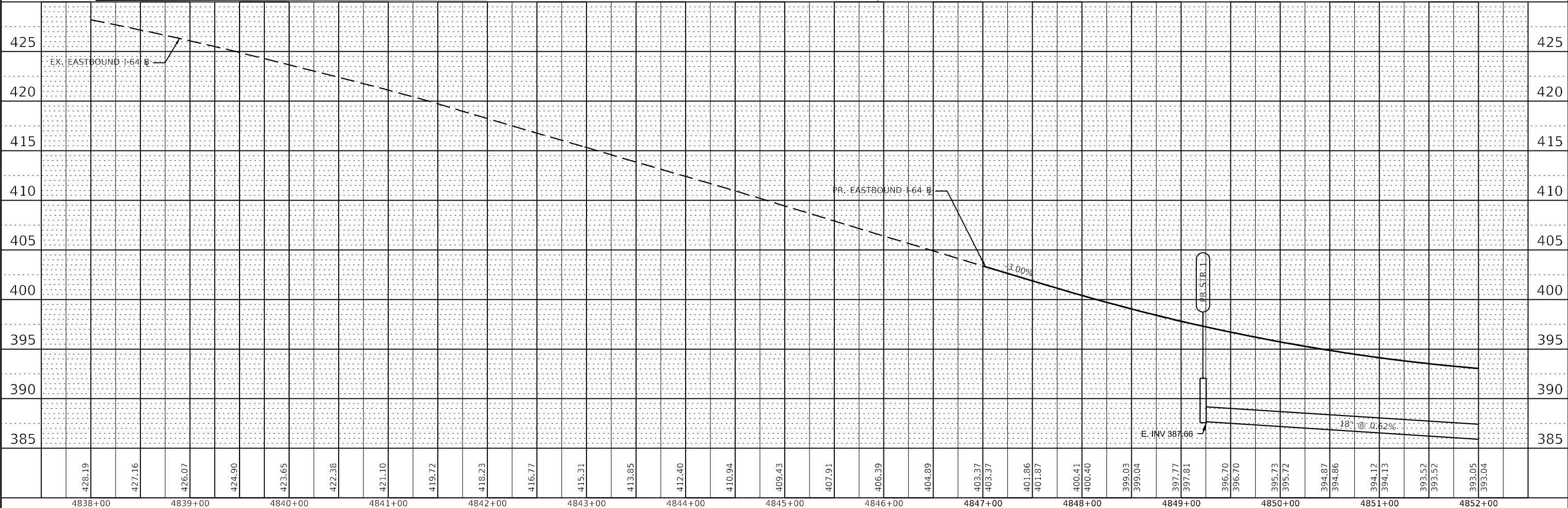
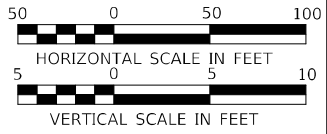

 Engineers & Architects	USER NAME = USWV706141	DESIGNED - JS	REVISED -	STATE OF ILLINOIS DEPARTMENT OF TRANSPORTATION	STORM SEWER AND DRAINAGE PLANS I-64			F.A.I. RTE. = 64	SECTION = (97-2) B-5	COUNTY = WHITE	TOTAL SHEETS = 578	SHEET NO. = 126	
	PLOT SCALE = 1:100	CHECKED - JCM	REVISED -		SCALE:	SHEET DR-1 OF 7 SHEETS	STA. TO STA.	CONTRACT NO. 78057					
	PLOT DATE = 8/10/2023	DATE = 08/11/2023	REVISED -			ILLINOIS FED. AID PROJECT FAI 64/WABASH RIVER							

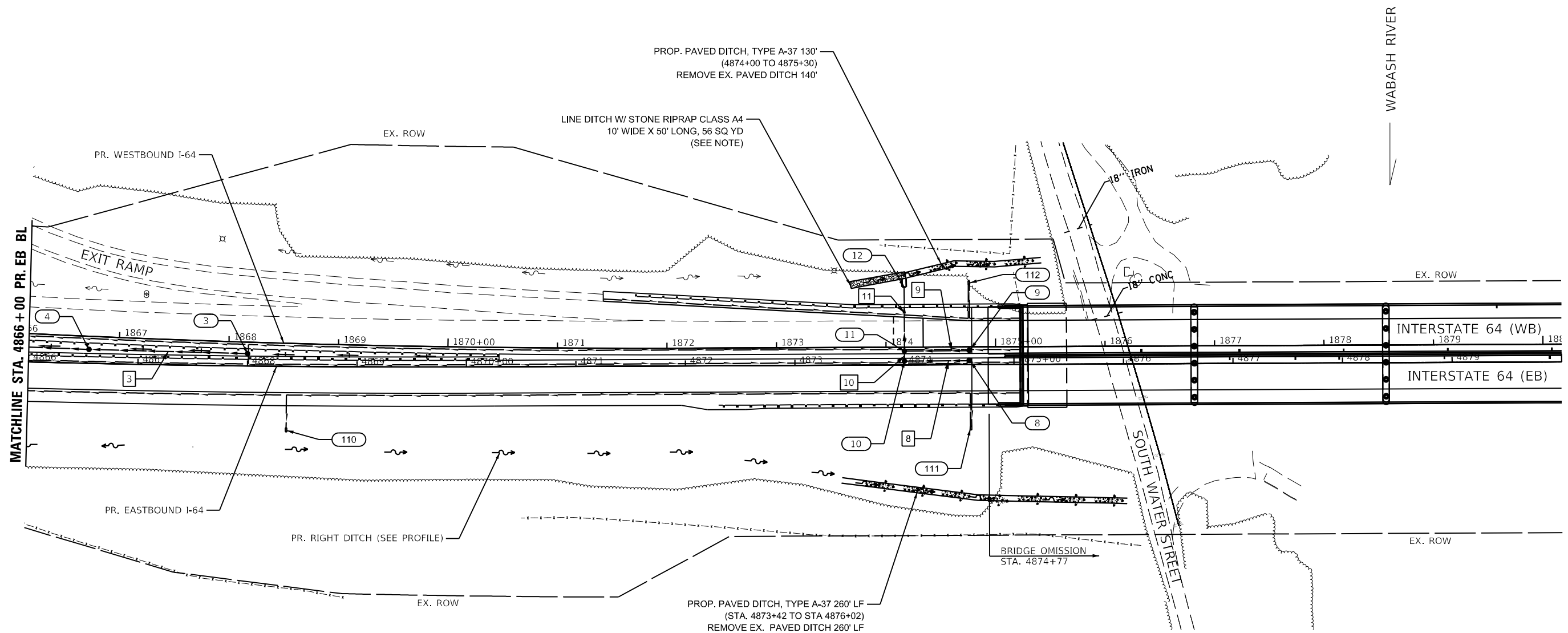

NOTE:
THE RIPRAP AND BEDDING THICKNESS SHALL BE IN
ARTICLE 281.04 OF THE STANDARD SPECIFICATIONS.

STR 3
INLETS TA T1F OL
STA 4868+00, 10.5' LT
RIM 409.72
INV 405.14

STR 4
INLETS TB T1F CL
STA 4866+55, 12.5' LT
RIM 408.39
INV 403.69 E
INV 403.19 W

STR 8
INLETS TA T24F&G
STA 4874+60, 5.9' LT
RIM 410.03
INV 405.74

STR 9
INLETS TA T24F&G
STA 4874+60, 10.1' LT
RIM 410.03
INV 405.47 W

STR 10
INLETS TB T24F&G
STA 4874+00, 5.9' LT
RIM 410.24
INV 405.45 E
INV 402.43 N

STR 11
INLETS TB T24F&G
STA 4874+00, 10.1' LT
RIM 410.24
INV 402.38 S
INV 402.38 N
INV 405.18 E

STR 12
CONC ES 542001 15 1:3
STA 4874+00, 78' LT
INV 402.10

PIPE 3
140' STORM SEW CL A 2 15
@ 1.04%
33 CU YD TBF

PIPE 8
58' STORM SEW CL A 2 15
@ 0.50% 13 CU YD TBF

PIPE 9
58' STORM SEW CL A 2 15
@ 0.50% 15 CU YD TBF

PIPE 10
5' STORM SEW CL A 2 15
@ 1.00% 5 CU YD TBF

PIPE 11
57' STORM SEW CL A 2 15
@ 0.49% 22 CU YD TBF

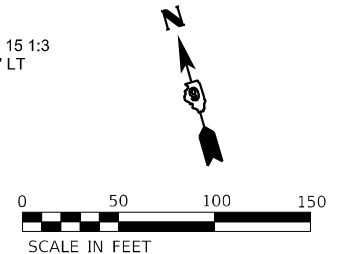

MODEL: I:\MODELS\NAME\... FILE NAME: I:\2023\CAD\Drawings\Drainage\DR78057-211-01.dwg



USER NAME = USIS706126	DESIGNED - JS	REVISED - 10/26/2023
	DRAWN - RTA	REVISED -
PLOT SCALE = 1:100	CHECKED - JCM	REVISED -
PLOT DATE = 10/25/2023	DATE - 08/11/2023	REVISED -

**STATE OF ILLINOIS
DEPARTMENT OF TRANSPORTATION**

STORM SEWER AND DRAINAGE PLANS			
I-64			
SCALE:	SHEET DR-3	OF 7 SHEETS	STA. TO STA.

F.A.I. RTE.	SECTION	COUNTY	TOTAL SHEETS	SHEET NO.
64	(97-2) B-5	WHITE	578	128
CONTRACT NO. 78057				
ILLINOIS FED. AID PROJECT FAI 64/WABASH RIVER				

PLAN	STANDARD	DATE
	PIOTTED	BY
NOTE BOOK NO.	ALIGNED	CHECKED
	CADD FILE NAME	

PROFILE	GRADES CHECKED	DATE
	STRUCTURE NOTATION	BY
NOTE BOOK NO.	STRUCTURE	CHECKED

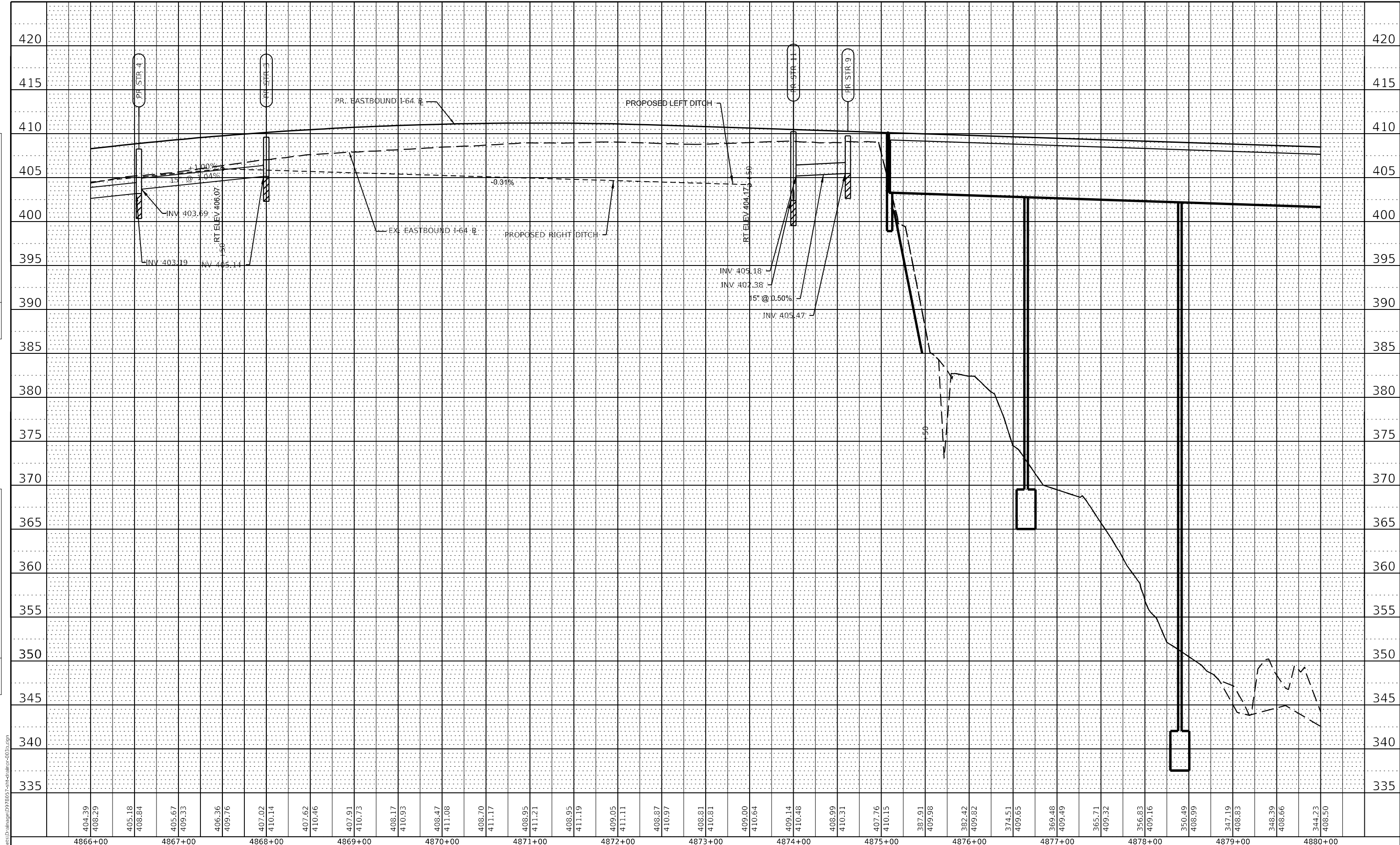

404.39	408.29	405.18	408.84	405.67	409.33	406.36	409.76	407.02	410.14	407.62	410.46	407.91	410.73	408.17	410.93	408.47	411.08	408.70	411.17	408.95	411.21	408.95	411.19	409.05	411.11	408.87	410.97	408.81	410.81	409.00	410.64	409.14	410.48	408.99	410.31	407.76	410.15	387.91	409.98	382.42	409.82	374.51	409.65	369.48	409.49	365.71	409.32	356.83	409.16	350.49	408.99	347.19	408.83	348.39	408.66	344.23	408.50
4866+00	4867+00	4868+00	4869+00	4870+00	4871+00	4872+00	4873+00	4874+00	4875+00	4876+00	4877+00	4878+00	4879+00	4880+00																																											



USER NAME = USRA706046	DESIGNED - JS	REVISED -
DRAWN - RTA	REVISED -	
PLLOT SCALE = 1:100	CHECKED - JCM	REVISED -
PLLOT DATE = 8/24/2023	DATE - 08/11/2023	REVISED -

**STATE OF ILLINOIS
DEPARTMENT OF TRANSPORTATION**

**STORM SEWER AND DRAINAGE PLANS
I-64**

SCALE: SHEET DR-4 OF 7 SHEETS STA. TO STA.

F.A.I. RTE.	SECTION	COUNTY	TOTAL SHEETS	SHEET NO.
64	(97-2) B-5	WHITE	578	129
CONTRACT NO. 78057				
ILLINOIS FED. AID PROJECT FAI 64/WABASH RIVER				

PLAN	SURVEYED	DATE
	PLOTTED	BY
	ALIGNED/CHECKED	
	NOTE BOOK	
	NO.	

PROFILE	SURVEYED	DATE
	PLOTTED	BY
	GRADES CHECKED	
	NOTE BOOK	
	NO.	

MODEL: S:\MODEL\NAMES
FILE NAME: E:\7660\CAD\1\Sheet\1\11.dwg (9/16/23 10:25:51 AM) (11/16/23 10:25:51 AM)

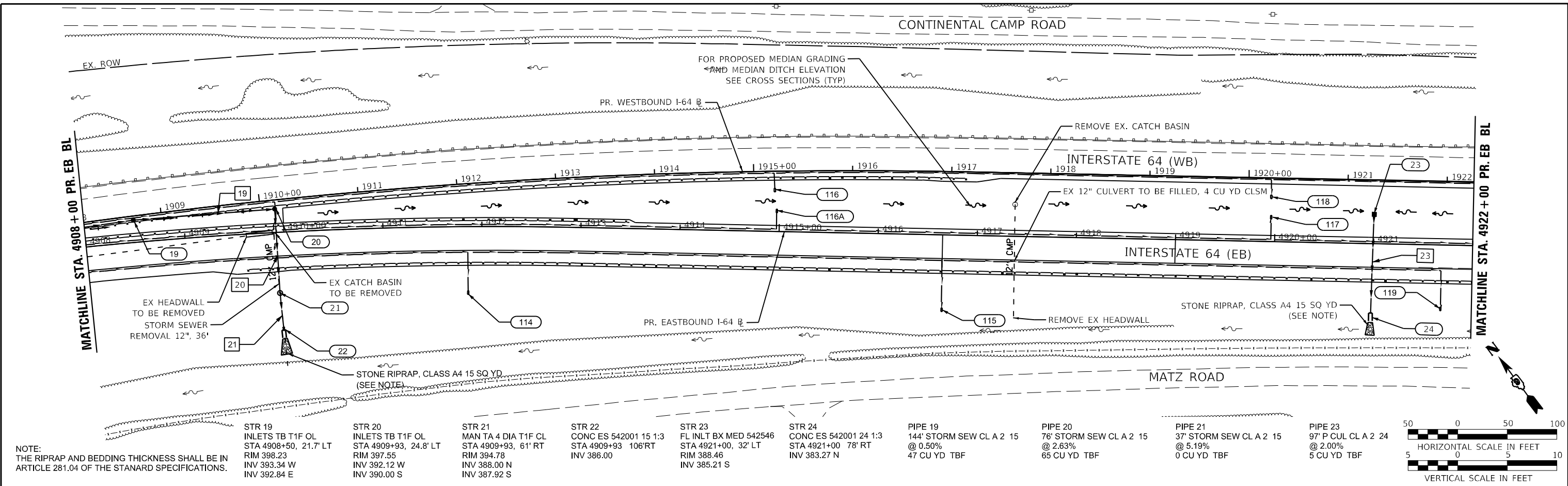

NOTE:
THE RIPRAP AND BEDDING THICKNESS SHALL BE IN
ARTICLE 281.04 OF THE STANARD SPECIFICATIONS.

STR 19 INLETS TB T1F OL STA 4908+50, 21.7' LT RIM 398.23 INV 393.34 W INV 392.84 E	STR 20 INLETS TB T1F OL STA 4909+93, 24.8' LT RIM 397.55 INV 392.12 W INV 390.00 S	STR 21 MAN TA 4 DIA T1F CL STA 4909+93, 61' RT RIM 394.78 INV 388.00 N INV 387.92 S	STR 22 CONC ES 542001 15 1:3 STA 4909+93 106'RT INV 386.00	STR 23 FL INLT BX MED 542546 STA 4921+00, 32' LT RIM 388.46 INV 385.21 S	STR 24 CONC ES 542001 24 1:3 STA 4921+00 78' RT INV 383.27 N	PIPE 19 144' STORM SEW CL A 2 15 @ 0.50% 47 CU YD TBF	PIPE 20 76' STORM SEW CL A 2 15 @ 2.63% 65 CU YD TBF	PIPE 21 37' STORM SEW CL A 2 15 @ 5.19% 0 CU YD TBF	PIPE 23 97' P CUL CL A 2 24 @ 2.00% 5 CU YD TBF
---	---	--	---	--	---	--	---	--	--

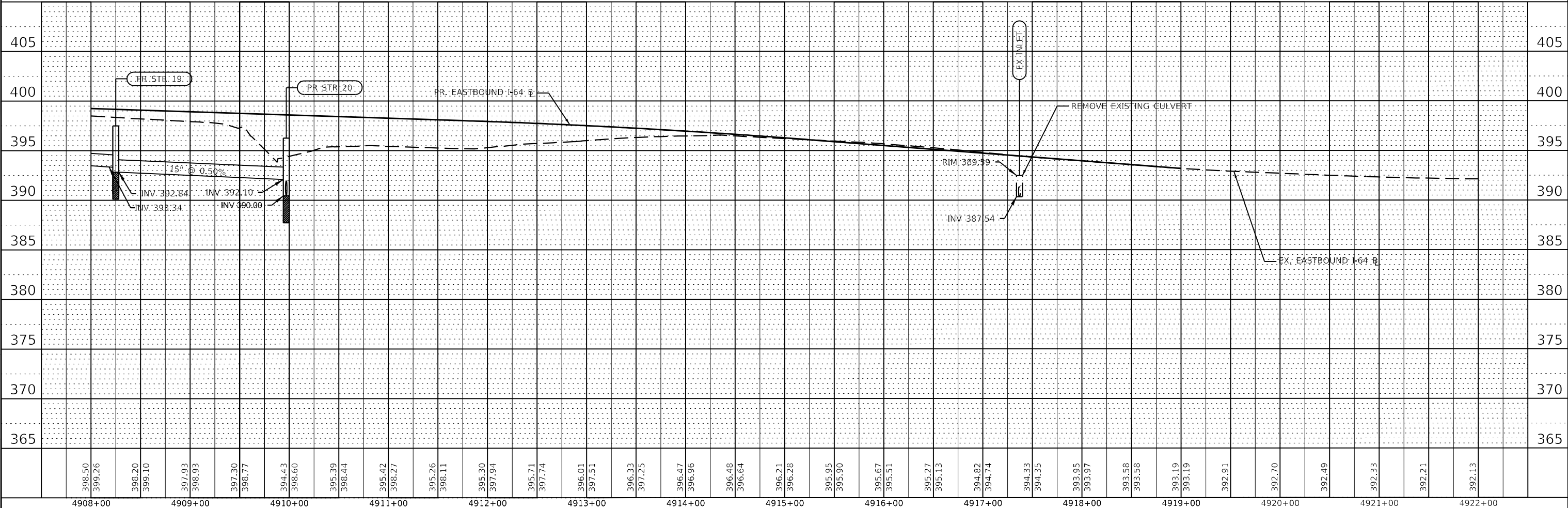
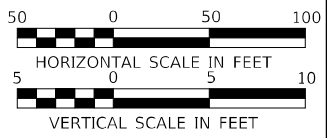

4908+00	4909+00	4910+00	4911+00	4912+00	4913+00	4914+00	4915+00	4916+00	4917+00	4918+00	4919+00	4920+00	4921+00	4922+00																																					
398.50	399.26	398.20	399.10	397.93	398.93	397.30	398.77	394.43	398.60	395.39	398.44	395.42	398.27	395.26	398.11	395.30	397.94	395.71	397.74	396.01	397.51	396.33	397.25	396.47	396.96	396.48	396.64	396.21	396.28	395.95	395.90	395.67	395.51	395.27	395.13	394.82	394.74	394.33	394.35	393.95	393.97	393.58	393.58	393.19	393.19	392.91	392.70	392.49	392.33	392.21	392.13

KNIGHT
Engineers & Architects

USER NAME = USJ5706126	DESIGNED - JS	REVISED - 10/26/2023
PLOT SCALE = 1:100,033	DRAWN - RTA	REVISED -
PLOT DATE = 10/25/2023	CHECKED - JCM	REVISED -
	DATE - 08/11/2023	REVISED -

**STATE OF ILLINOIS
DEPARTMENT OF TRANSPORTATION**

STORM SEWER AND DRAINAGE PLANS			
I-64			
SCALE:	SHEET DR-6	OF 7	SHEETS
	STA.		TO STA.

F.A.I. RTE.	SECTION	COUNTY	TOTAL SHEETS	SHEET NO.
64	(97-2) B-5	WHITE	578	131
CONTRACT NO. 78057				
ILLINOIS FED. AID PROJECT FAI 64/WABASH RIVER				

EROSION CONTROL GENERAL NOTES

1. THE EROSION CONTROL MEASURES INDICATED ON THE PLANS ARE THE MINIMUM REQUIREMENTS. ADDITIONAL MEASURES MAY BE REQUIRED, AS DIRECTED BY THE ENGINEER. EROSION CONTROL ITEMS ARE CONSIDERED TO BE A HIGH PRIORITY ON THIS CONTRACT. THE CONTRACTOR IS RESPONSIBLE FOR INSTALLATION OF ANY ADDITIONAL EROSION CONTROL MEASURES NECESSARY TO PREVENT EROSION AND SEDIMENTATION AS DETERMINED BY THE RE.
2. IDOT SPECIFICATION 280.03 REQUIRES WORK TO BE COORDINATED SO THAT NO MORE THAN 10 ACRES ARE DISTURBED AT A TIME, PARTICULARLY AREAS WHICH DISCHARGE TO WETLAND/WOVS SITES. UNDER NO CIRCUMSTANCES SHALL THE CONTRACTOR PROLONG FINAL GRADING AND SHAPING SO THAT THE ENTIRE PROJECT CAN BE PERMANENTLY SEEDED AT ONE TIME.
3. THE CONTRACTOR SHALL TAKE ALL PRECAUTIONS TO PREVENT POLLUTION OF STORM WATER AND SHALL FOLLOW IEPA & IDOT CONSTRUCTION MANUAL.
4. SOIL DISTURBANCE SHALL BE CONDUCTED IN SUCH A MANNER AS TO MINIMIZE EROSION. SOIL STABILIZATION MEASURES SHALL CONSIDER THE TIME OF YEAR, SITE CONDITIONS AND THE USE OF TEMPORARY OR PERMANENT MEASURES.
5. THE MAINTENANCE AND REPAIR OR REPLACEMENT OF EROSION CONTROL ITEMS, WHEN DIRECTED BY THE ENGINEER, WILL NOT BE PAID FOR SEPARATELY, BUT SHALL BE INCLUDED IN THE COST OF THE ASSOCIATED PAY ITEMS. ALL ESC MEASURES WILL BE MAINTAINED IN ACCORDANCE WITH THE IDOT EROSION AND SEDIMENT CONTROL FIELD GUIDE FOR CONSTRUCTION INSPECTION AND IDOT'S BEST MANAGEMENT PRACTICES MAINTENANCE GUIDE:
(<http://www.idot.illinois.gov/transportation-system/environment/erosion-and-sediment-control>)
6. ALL STORM SEWER FACILITIES THAT ARE OR WILL BE FUNCTIONING DURING CONSTRUCTION SHALL BE PROTECTED, FILTERED OR OTHERWISE TREATED TO REMOVE SEDIMENT. MUD AND SEDIMENT DEPOSITS SHALL BE REMOVED FROM THE ROADWAY AT THE END OF EACH WORK DAY BY SHOVELING AND/OR SWEEPING.
7. INLET AND PIPE PROTECTION SHALL BE PLACED ON ALL INLET BOXES, INLETS, AND MANHOLES WITH OPEN GRATES WITHIN UNPAVED DRAINAGE AREAS.
8. TEMPORARY EROSION CONTROL SEEDING MIXTURE WILL DEPEND ON THE TIME OF YEAR SEED IS TO BE APPLIED AND SHALL BE IN ACCORDANCE WITH ARTICLE 1081.15(G) OF THE STANDARD SPECIFICATIONS. SEEDING OF ALL AREAS DISTURBED BY CONSTRUCTION SHALL COMMENCE WITHIN 1 DAY AND BE COMPLETE WITHIN 48 HOURS FOR ANY PORTION OF THE SITE THAT WILL BE IDLE FOR MORE THAN 14 DAYS. IF THAT PORTION OF THE SITE WILL BECOME ACTIVE AGAIN AFTER 14 DAYS, TEMPORARY STABILIZATION MEASURES CAN BE USED.
9. DUST CONTROL MEASURES WILL BE IMPLEMENTED IN ACCORDANCE WITH ARTICLE 107.36 OF THE STANDARD SPECIFICATIONS.
10. WHENEVER DURING CONSTRUCTION OPERATIONS, LOOSE MATERIAL IS DEPOSITED IN THE FLOW LINE OF GUTTERS, DRAINAGE STRUCTURES, DITCHES, ETC., SUCH THAT THE NATURAL FLOW LINE OF WATER IS OBSTRUCTED, THE LOOSE MATERIAL SHALL BE REMOVED AT THE CLOSE OF EACH WORKING DAY. AT THE CONCLUSION OF THE CONSTRUCTION OPERATIONS, ALL DRAINAGE STRUCTURES AND FLOW LINES SHALL BE FREE FROM DIRT AND DEBRIS. THIS WORK WILL NOT BE PAID FOR SEPARATELY, BUT SHALL BE CONSIDERED AS INCLUDED IN THE UNIT BID PRICES OF THE CONTRACT AND NO ADDITIONAL COMPENSATION WILL BE ALLOWED.
11. BROADCASTING OF THE SEED BY MACHINE, HAND METHODS, HYDRAULIC SEEDING OR OTHER METHODS APPROVED BY THE ENGINEER WILL BE ALLOWED FOR TEMPORARY EROSION CONTROL SEEDING.
12. TOPSOIL AND FERTILIZER NUTRIENTS ARE NOT REQUIRED FOR TEMPORARY EROSION CONTROL SEEDING.
13. SEED BED PREPARATION WILL NOT BE REQUIRED FOR TEMPORARY EROSION CONTROL SEEDING IF THE SOIL IS IN A LOOSE CONDITION. LIGHT DISKING SHALL BE DONE IF THE SOIL IS HARD PACKED OR CAKED.
14. ALL PERIMETER EROSION BARRIER AND TEMPORARY FENCE SHALL BE INSTALLED WITHIN THE TEMPORARY EASEMENT, PROPOSED RIGHT-OF-WAY OR EXISTING RIGHT-OF-WAY.
15. EROSION CONTROL BLANKET SHALL BE PLACED IN ACCORDANCE WITH THE REQUIREMENTS OF THE STANDARD SPECIFICATIONS AFTER TEMPORARY EROSION CONTROL SEEDING HAS BEEN COMPLETED ON ALL AREAS WITH SLOPES OF 1:3 (V:H) OR STEEPER, AS SHOWN ON THE PLANS, OR AS DIRECTED BY THE ENGINEER.
16. THE CONSTRUCTION LIMITS WILL BE STAKED BY THE ENGINEER PRIOR TO COMMENCING CONSTRUCTION. THE CONSTRUCTION LIMITS MAY BE ADJUSTED BY THE ENGINEER AND NO ADDITIONAL COMPENSATION WILL BE PAID TO THE CONTRACTOR FOR CHANGED CONSTRUCTION LIMITS.
18. ALL EXISTING STRUCTURES OR PIPES NOT SHOWN ON EROSION CONTROL PLANS SHALL BE REMOVED (OR PLUGGED UNTIL REMOVAL IS POSSIBLE DURING THE CONSTRUCTION SO THAT NO SEDIMENT CAN ENTER THE DRAINAGE SYSTEM. THIS SHALL BE CONSIDERED IN THE COST OF THE REMOVAL OF EXISTING STRUCTURES.
19. ALL TEMPORARY CONNECTIONS FOR TEMPORARY PIPE CULVERTS INTO EXISTING/PROPOSED STRUCTURES/PIPES SHALL BE CONSIDERED INCLUDED IN THE UNIT PRICE FOR PIPE CULVERT OF THE CLASS, TYPE, SIZE (TEMPORARY).
20. SALVAGED TOPSOIL SHALL BE PLACED ON WELL DRAINED LAND AWAY FROM INTERMITTENT AND LIVE STREAMS OR WETLANDS WITH THE APPROPRIATE RUNOFF CONTROL AND SEDIMENT CONTROL MEASURES INSTALLED AROUND THE STORAGE SITE, AND APPROPRIATE STABILIZATION SHALL BE APPLIED IMMEDIATELY WHEN THE TOPSOIL SHALL BE UNDISTURBED FOR 14 DAYS, AND STABILIZATION SHALL BE COMPLETED WITHIN 14 DAYS. THE CONTRACTOR WILL PROVIDE AN ADEQUATE QUANTITY OF SILT FENCE TO CONTROL THE PERIMETER OF THE STOCK PILE.
21. SEDIMENT LADEN DEWATERING DISCHARGE MUST BE DIRECTED TO AN APPROVED SEDIMENT TRAPPING MEASURE PRIOR TO RELEASE FROM THE SITE.
22. ALL EROSION AND SEDIMENT CONTROL (ESC) MEASURES SHALL BE CHECKED WEEKLY AND AFTER EACH RAINFALL, 0.5 INCHES OR GREATER IN A 24 HOUR PERIOD, OR EQUIVALENT SNOWFALL. ADDITIONALLY DURING WINTER MONTHS, ALL MEASURES SHALL BE CHECKED AFTER EACH SIGNIFICANT SNOWFALL.
23. THIS PROJECT REQUIRES A US ARMY CORPS OF ENGINEERS (USACE) 404 PERMIT THAT WILL BE SECURED BY THE DEPARTMENT. AS A CONDITION OF THIS PERMIT, THE CONTRACTOR WILL NEED TO SUBMIT AN IN-STREAM WORK PLAN TO THE DEPARTMENT FOR APPROVAL. GUIDELINES ON ACCEPTABLE IN-STREAM WORK TECHNIQUES CAN BE FOUND ON THE USACE WEBSITE (WWW.LRC.USACE.ARMY.MIL/). THE USACE DEFINES AND DETERMINES IN-STREAM WORK. THE COST OF ALL MATERIALS AND LABOR NECESSARY TO COMPLY WITH THE ABOVE PROVISIONS TO PREPARE AND IMPLEMENT AN IN-STREAM WORK PLAN WILL NOT BE PAID FOR SEPARATELY, BUT SHALL BE CONSIDERED AS INCLUDED IN THE UNIT BID PRICES OF THE CONTRACT AND NO ADDITIONAL COMPENSATION WILL BE ALLOWED.
24. PIPES BEING CONSTRUCTED IN STAGES SHALL BE PLUGGED BEFORE BACKFILLING AND FREE OF DEBRIS WHEN FINAL CONNECTION IS MADE.
25. THE CONTRACTOR SHALL PROVIDE TO THE RE A PLAN TO ENSURE THAT A STABILIZED FLOW LINE WILL BE PROVIDED DURING STORM SEWER CONSTRUCTION. THE USE OF A STABILIZED FLOW LINE BETWEEN INSTALLED STORM SEWER AND OPEN DISTURBANCE WILL REDUCE THE POTENTIAL FOR THE OFFSITE DISCHARGE OF SEDIMENT-BEARING WATERS, ESPECIALLY WHEN RAIN IS FORECASTED, SO THAT FLOW WILL NOT ERODE. LACK OF APPROVED PLAN OR FAILURE TO COMPLY MAY RESULT IN AN ESC DEFICIENCY DEDUCTION IN ACCORDANCE WITH SSRBC ARTICLE 105.03.
26. WETLAND AREAS OUTSIDE THE WORK ZONE ARE TO BE AVOIDED. IF THE CONTRACTOR SHOULD ENCROACH UPON ANY WETLAND AREA THAT IS NOT WITHIN THE CONSTRUCTION LIMITS AND/OR PERMITTED FOR IMPACT THROUGH THE USAGE, THE CONTRACTOR IS SUBJECT TO FINES. CONTRACTOR SHALL NOTIFY THE ENGINEER IMMEDIATELY OF ANY WETLAND IMPACTS OUTSIDE THE WORK ZONE. IMPACTED AREAS SHALL BE REPAIRED IMMEDIATELY BY THE CONTRACTOR IN COORDINATION WITH AND TO THE SATISFACTION OF THE USAGE.
27. ALL WETLANDS, WATERS OF THE U.S. AND OPEN WATER DETENTION FACILITIES ARE SUBJECT TO THE REVIEW AND APPROVAL BY RESOURCE AND REGULATORY AGENCIES. THOSE AGENCIES INCLUDE BUT ARE NOT LIMITED TO USACE, THE ILLINOIS DEPARTMENT OF NATURAL RESOURCES, THE ILLINOIS ENVIRONMENTAL PROTECTION AGENCY, AND THE COUNTY SOILD AND WATER CONSERVATION DISTRICTS.

MODEL: 4400BELNAMES
FILE NAME: 017660\CAD\Drawings\Erosion_Control\7660-01-ec-ctrlnotes01.dgn

KNIGHT Engineers & Architects	USER NAME = USWV706141	DESIGNED - JS	REVISED -
		DRAWN - RTA	REVISED -
	PLOT SCALE = 1:2,00008	CHECKED - JCM	REVISED -
	PLOT DATE = 8/10/2023	DATE - 08/11/2023	REVISED -







**STATE OF ILLINOIS
DEPARTMENT OF TRANSPORTATION**

**TEMPORARY DRAINAGE & EROSION CONTROL
LEGEND AND GENERAL NOTES**

SCALE: SHEET EC-1 OF 23 SHEETS STA. TO STA.

F.A.I. RTE.	SECTION	COUNTY	TOTAL SHEETS	SHEET NO.
64	(97-2) B-5	WHITE	578	133
CONTRACT NO. 78057				
ILLINOIS FED. AID PROJECT FAI 64/WABASH RIVER				

LEGEND

	TEMPORARY PAVEMENT		PERIMETER EROSION BARRIER
	TEMPORARY PAVEMENT INSTALLED IN A PREVIOUS STAGE		INLET AND PIPE PROTECTION
	EROSION CONTROL BLANKET AND TEMPORARY EROSION CONTROL SEEDING		TEMPORARY DITCH CHECKS
	EROSION CONTROL BLANKET INSTALLED IN A PREVIOUS STAGE		

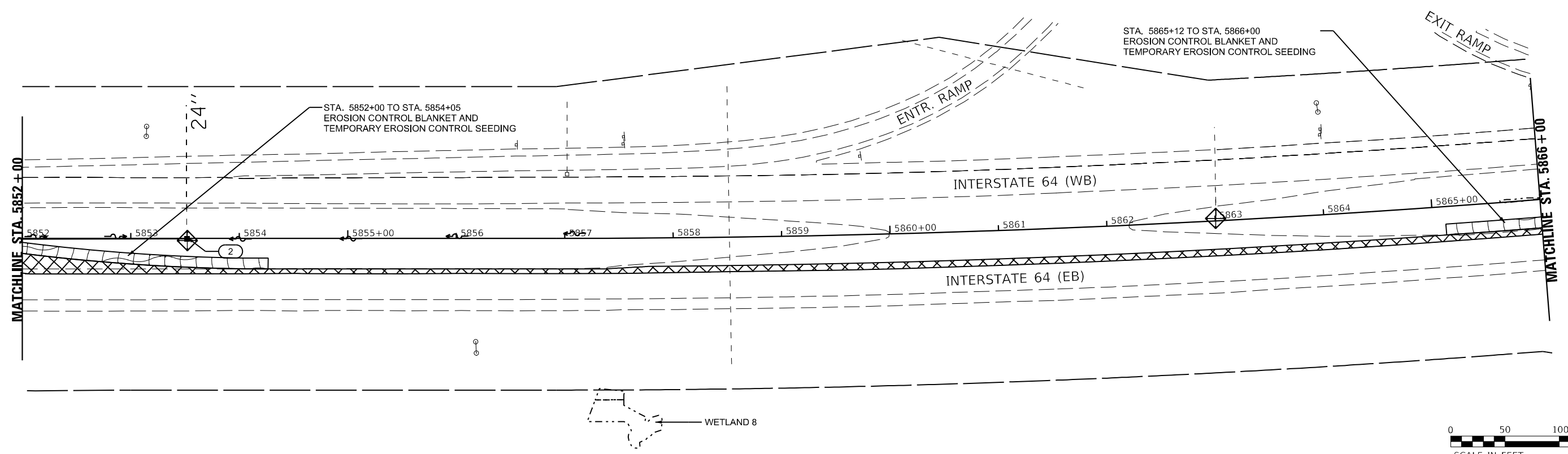
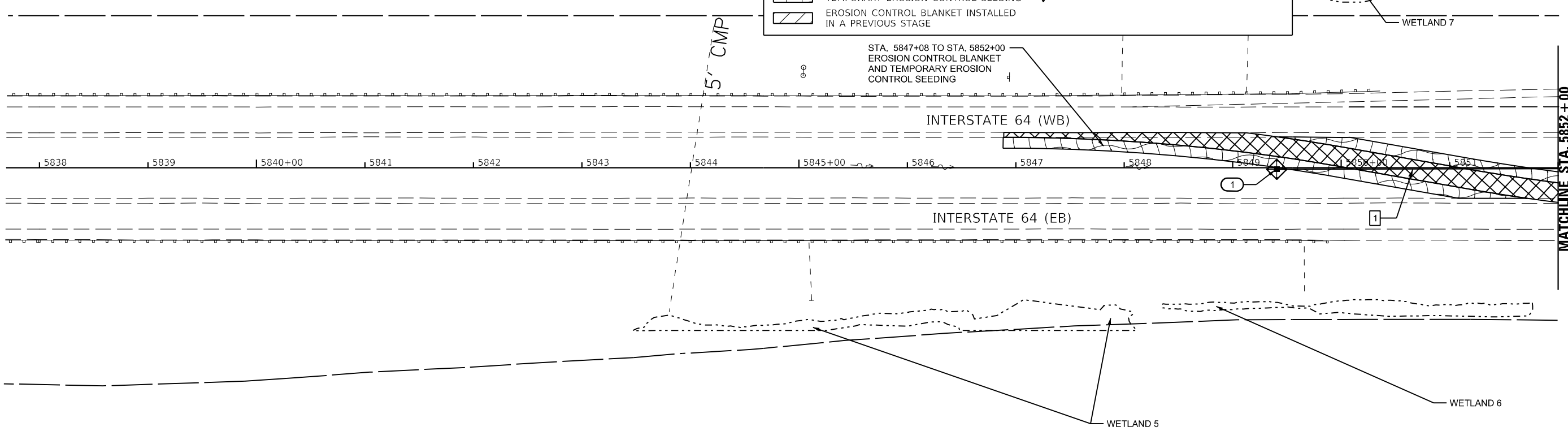

MODEL: 4400\BENAMES
 FILE NAME: 117660\CAD\Sheet\Erosion_Control\PreStage_01\0918507-eh-ec-erob-control-prestage_1.dwg









USER NAME = USIM706109	DESIGNED - JS	REVISED - 11/15/2023
PLOT SCALE = 1:100	DRAWN - RTA	REVISED -
PLOT DATE = 11/13/2023	CHECKED - JCM	REVISED -
	DATE - 08/11/2023	REVISED -

**STATE OF ILLINOIS
DEPARTMENT OF TRANSPORTATION**

EROSION CONTROL - PRESTAGE 1		
I-64		
SCALE:	SHEET EC-2 OF 23 SHEETS	STA. TO STA.

F.A.I. RTE.	SECTION	COUNTY	TOTAL SHEETS	SHEET NO.
64	(97-2) B-5	WHITE	578	134
CONTRACT NO. 78057				
ILLINOIS FED. AID PROJECT FAI 64/WABASH RIVER				

LEGEND

-  TEMPORARY PAVEMENT
-  TEMPORARY PAVEMENT INSTALLED IN A PREVIOUS STAGE
-  EROSION CONTROL BLANKET AND TEMPORARY EROSION CONTROL SEEDING
-  EROSION CONTROL BLANKET INSTALLED IN A PREVIOUS STAGE
-  PERIMETER EROSION BARRIER
-  INLET AND PIPE PROTECTION
-  TEMPORARY DITCH CHECKS

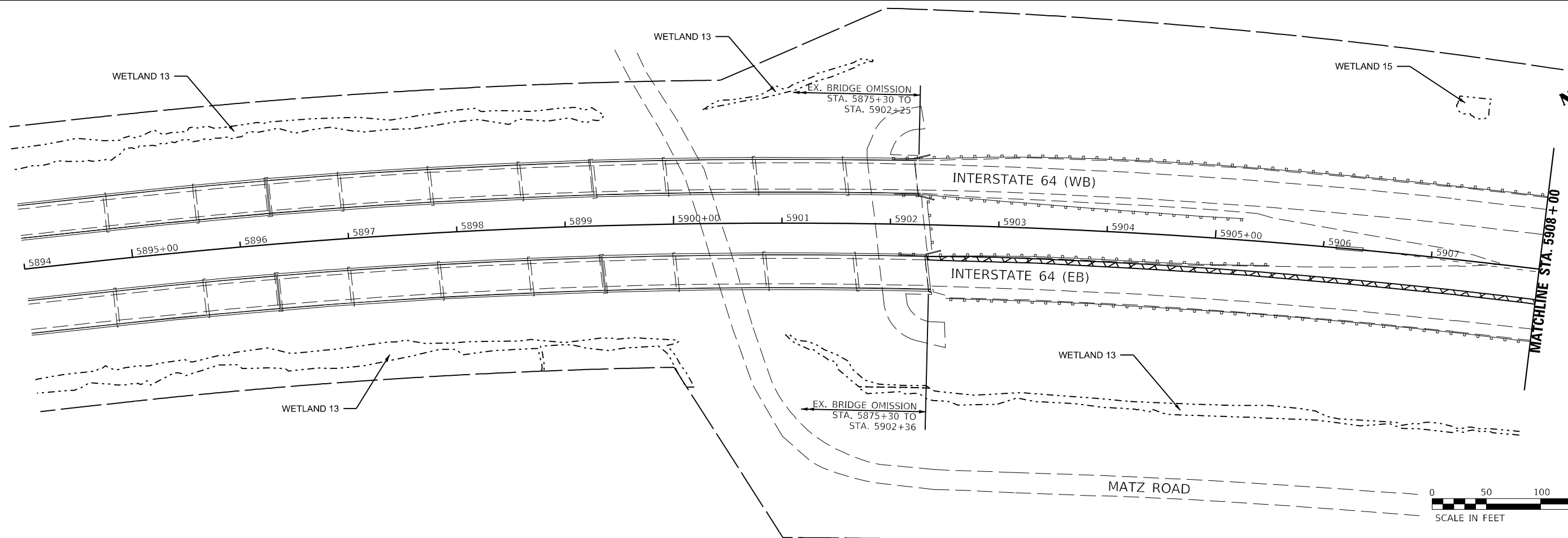
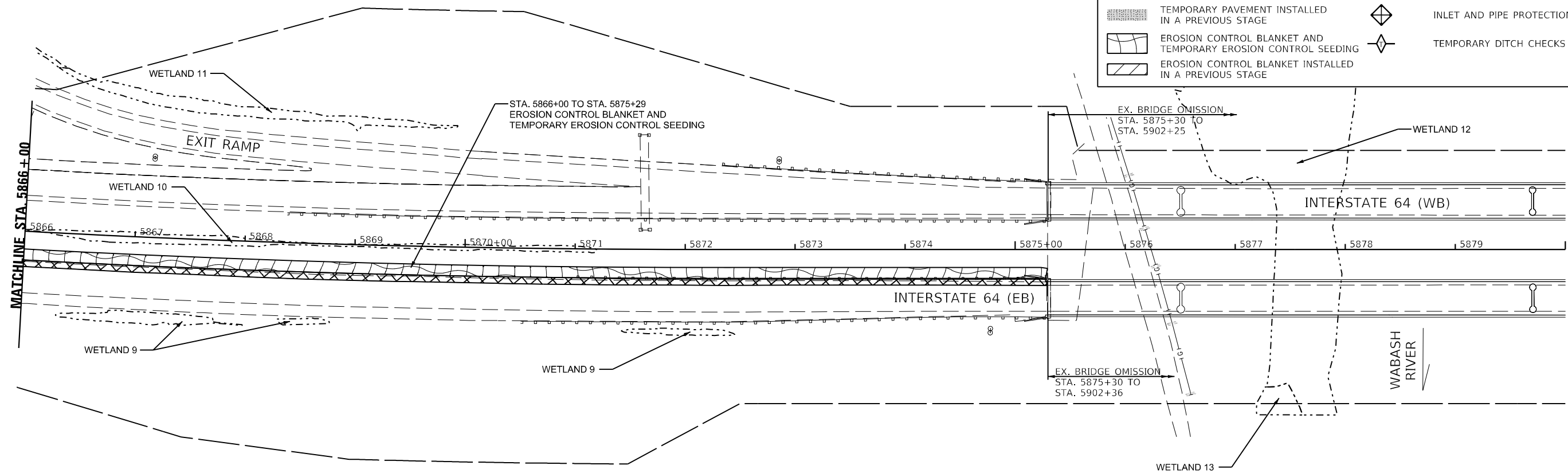

MODEL: \\4002\BEN\NAMEK FILE: \\4002\CAD\IS\vector\Erosion_Control\PreStage_01\10978507-eh-ec-erob-control-prestage_1-02.dgn

KNIGHT
Engineers & Architects







USER NAME = USIM706109	DESIGNED - JS	REVISED - 11/15/2023
PLOT SCALE = 1:100	DRAWN - RTA	REVISED -
PLOT DATE = 11/13/2023	CHECKED - JCM	REVISED -
	DATE - 08/11/2023	REVISED -

**STATE OF ILLINOIS
DEPARTMENT OF TRANSPORTATION**

EROSION CONTROL - PRESTAGE 1			
I-64			
SCALE:	SHEET EC-3	OF 23 SHEETS	STA. TO STA.

F.A.I. RTE.	SECTION	COUNTY	TOTAL SHEETS	SHEET NO.
64	(97-2) B-5	WHITE	578	135
CONTRACT NO. 78057				
ILLINOIS FED. AID PROJECT FAI 64/WABASH RIVER				

LEGEND

-  TEMPORARY PAVEMENT
-  TEMPORARY PAVEMENT INSTALLED IN A PREVIOUS STAGE
-  EROSION CONTROL BLANKET AND TEMPORARY EROSION CONTROL SEEDING
-  EROSION CONTROL BLANKET INSTALLED IN A PREVIOUS STAGE
-  PERIMETER EROSION BARRIER
-  INLET AND PIPE PROTECTION
-  TEMPORARY DITCH CHECKS

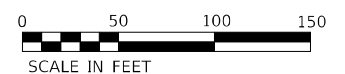
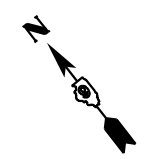
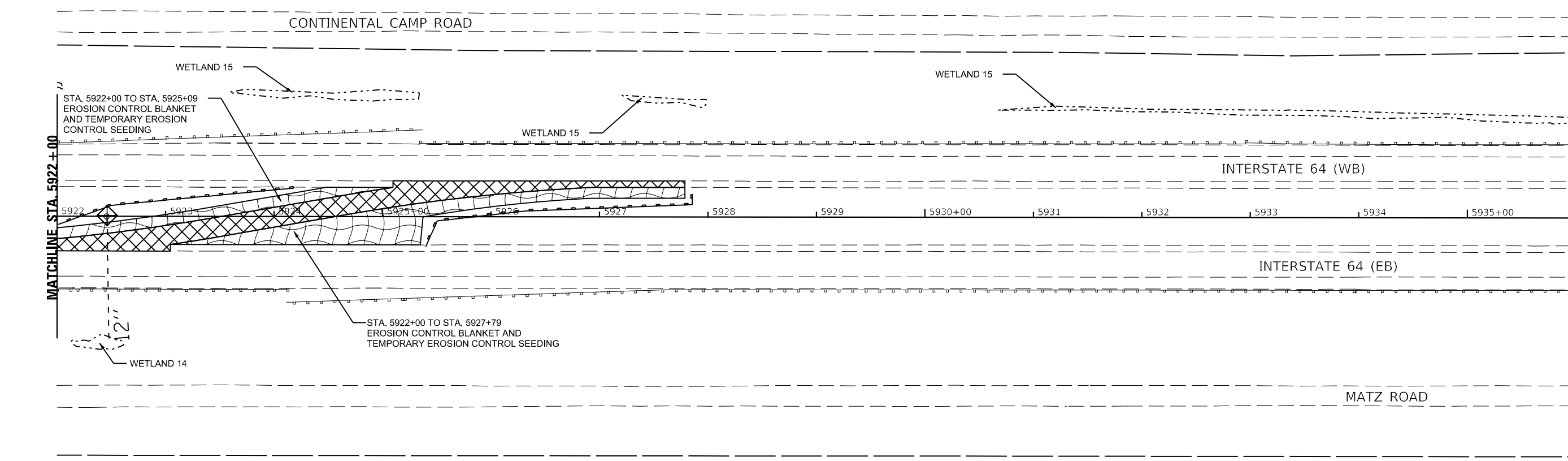
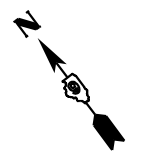
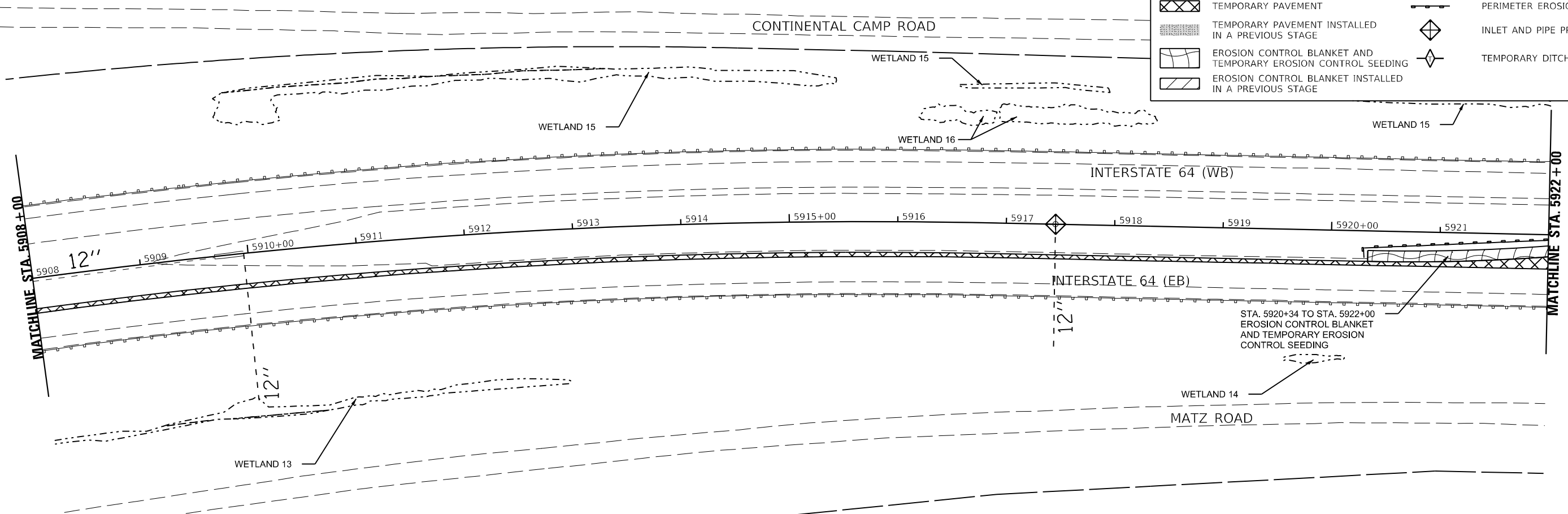

MODEL: 44002\BEN\MEK
 FILE: MATZ_EC-4\I-64\ECAD\USVect\Erosion_Control\PreStage_01\0918307-eh-ec-erob-control-prestage_1-03.dgn



USER NAME = USRA706046	DESIGNED - JS	REVISED - 11/15/2023
PLOT SCALE = 1:100	DRAWN - RTA	REVISED -
PLOT DATE = 11/10/2023	CHECKED - JCM	REVISED -
	DATE - 08/11/2023	REVISED -

**STATE OF ILLINOIS
DEPARTMENT OF TRANSPORTATION**

EROSION CONTROL - PRESTAGE 1			
I-64			
SCALE:	SHEET EC-4 OF 23 SHEETS	STA.	TO STA.

F.A.I. RTE.	SECTION	COUNTY	TOTAL SHEETS	SHEET NO.
64	(97-2) B-5	WHITE	578	136
CONTRACT NO. 78057				
ILLINOIS FED. AID PROJECT FAI 64/WABASH RIVER				

LEGEND

	TEMPORARY PAVEMENT		PERIMETER EROSION BARRIER
	TEMPORARY PAVEMENT INSTALLED IN A PREVIOUS STAGE		INLET AND PIPE PROTECTION
	EROSION CONTROL BLANKET AND TEMPORARY EROSION CONTROL SEEDING		TEMPORARY DITCH CHECKS
	EROSION CONTROL BLANKET INSTALLED IN A PREVIOUS STAGE		

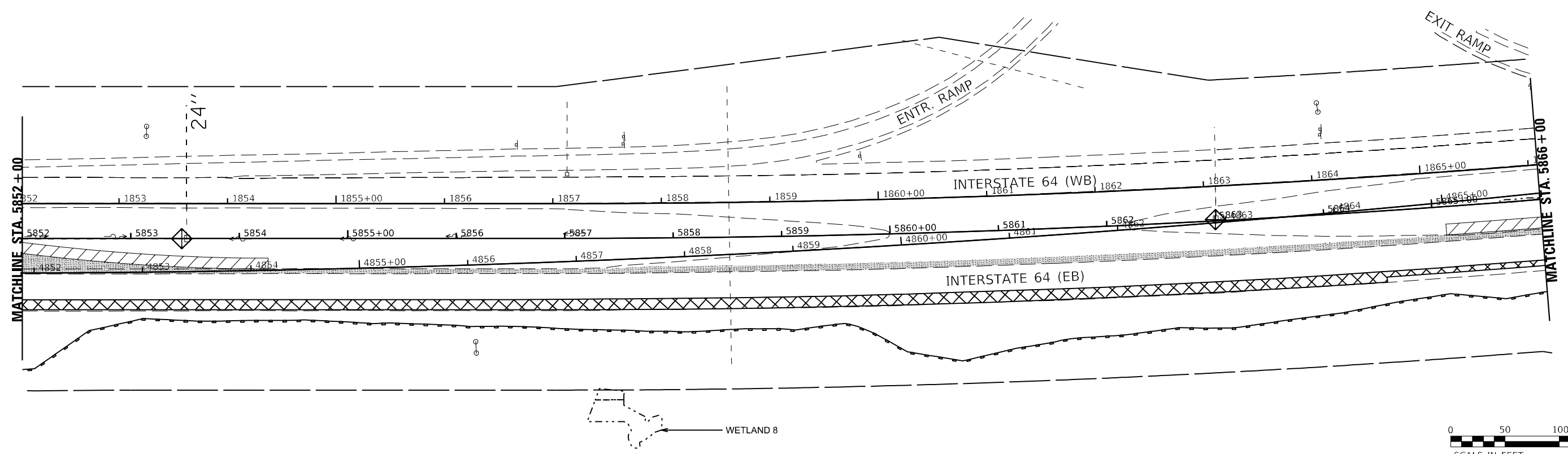
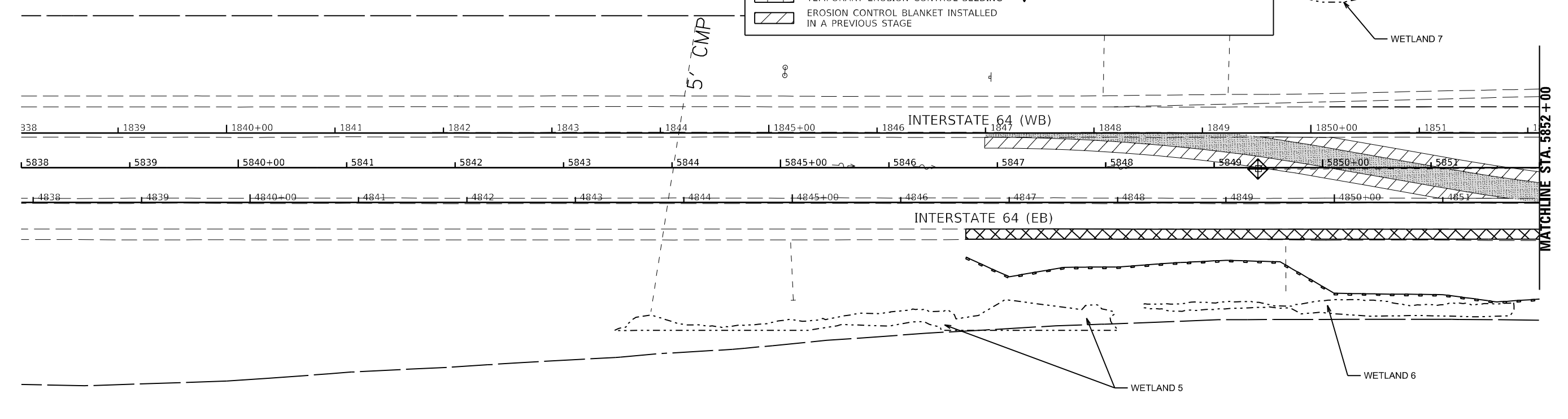

MODEL: I:\MODELS\NAME\ FILE: NAME: I:\2023\CAD\Drawings\Erosion_Control\PreStage_02\101918307-eh-ec-control-prestage_2-01.dwg
 EC-5



USER NAME = USRA706046	DESIGNED - JS	REVISED - 11/15/2023
DRAWN - RTA	REVISOR -	
CHECKED - JCM	REVISOR -	
DATE - 08/11/2023	REVISOR -	
PLOT SCALE = 1:100		
PLOT DATE = 11/10/2023		







STATE OF ILLINOIS
DEPARTMENT OF TRANSPORTATION

EROSION CONTROL - PRESTAGE 2
I-64

SCALE: SHEET EC-5 OF 23 SHEETS STA. TO STA.

F.A.I. RTE.	SECTION	COUNTY	TOTAL SHEETS	SHEET NO.
64	(97-2) B-5	WHITE	578	137
CONTRACT NO. 78057				
ILLINOIS FED. AID PROJECT FAI 64/WABASH RIVER				

LEGEND

-  TEMPORARY PAVEMENT
-  TEMPORARY PAVEMENT INSTALLED IN A PREVIOUS STAGE
-  EROSION CONTROL BLANKET AND TEMPORARY EROSION CONTROL SEEDING
-  EROSION CONTROL BLANKET INSTALLED IN A PREVIOUS STAGE
-  PERIMETER EROSION BARRIER
-  INLET AND PIPE PROTECTION
-  TEMPORARY DITCH CHECKS

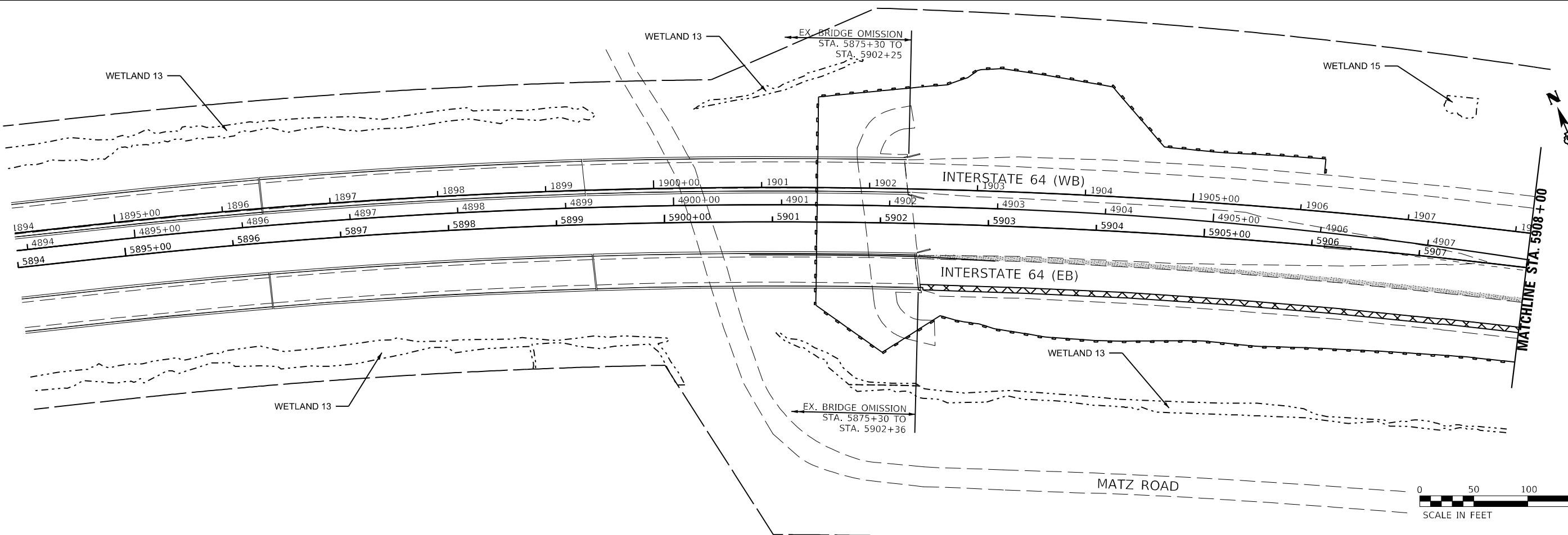
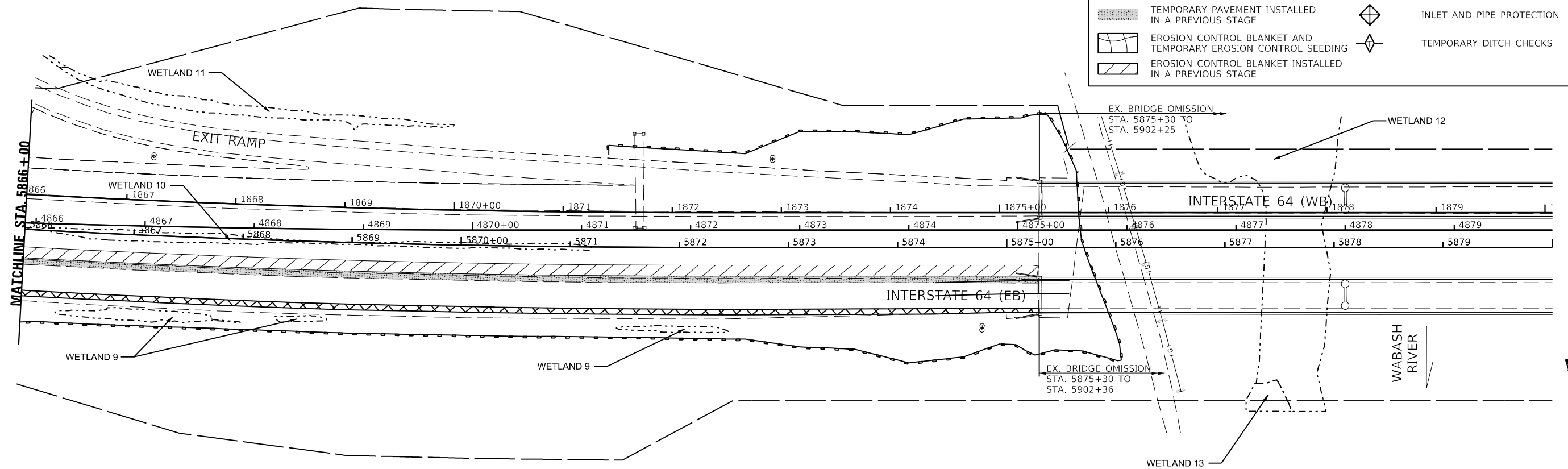

MODEL: \\MODELS\NAME: FILE: \\MAIL: \21660\CAD\Projects\Erosion_Control\PreStage_02\10978307-eh-erose-control-prestage_2.dwg



USER NAME = USJM706109	DESIGNED - JS	REVISED - 11/15/2023
PLOT SCALE = 1:100	DRAWN - RTA	REVISED -
PLOT DATE = 11/13/2023	CHECKED - JCM	REVISED -
	DATE - 08/11/2023	REVISED -

**STATE OF ILLINOIS
DEPARTMENT OF TRANSPORTATION**





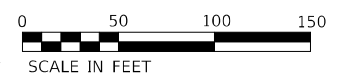

**EROSION CONTROL - PRESTAGE 2
I-64**

SCALE: SHEET EC-6 OF 23 SHEETS STA. TO STA.

F.A.I. RTE.	SECTION	COUNTY	TOTAL SHEETS	SHEET NO.
64	(97-2) B-5	WHITE	578	138
CONTRACT NO. 78057				
ILLINOIS FED. AID PROJECT FAI 64/WABASH RIVER				



LEGEND

-  TEMPORARY PAVEMENT
-  TEMPORARY PAVEMENT INSTALLED IN A PREVIOUS STAGE
-  EROSION CONTROL BLANKET AND TEMPORARY EROSION CONTROL SEEDING
-  EROSION CONTROL BLANKET INSTALLED IN A PREVIOUS STAGE
-  PERIMETER EROSION BARRIER
-  INLET AND PIPE PROTECTION
-  TEMPORARY DITCH CHECKS

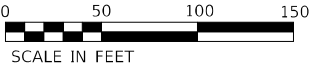
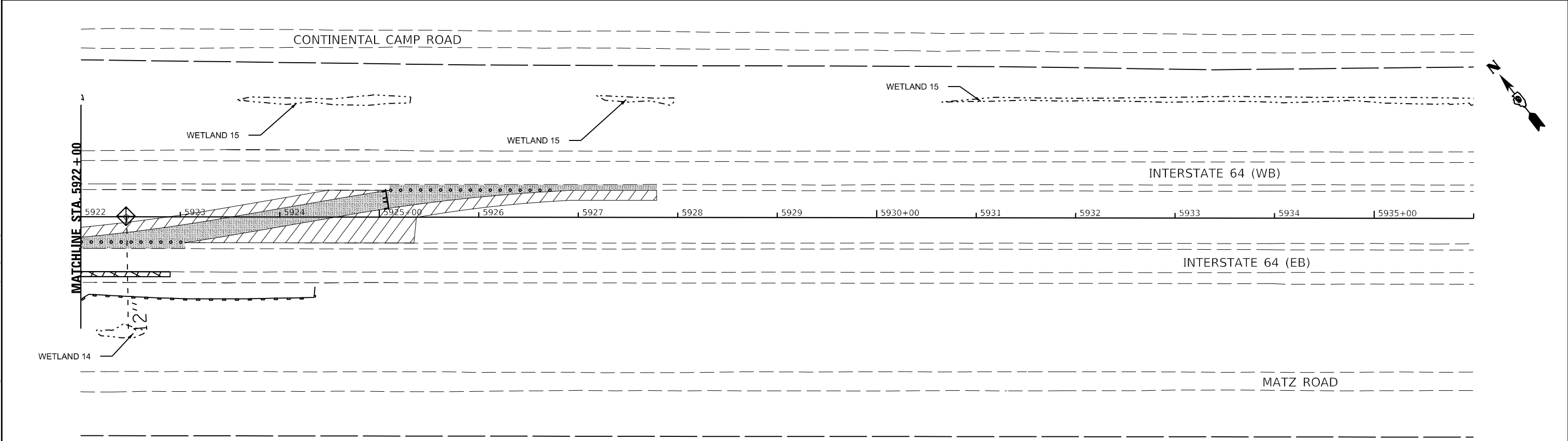
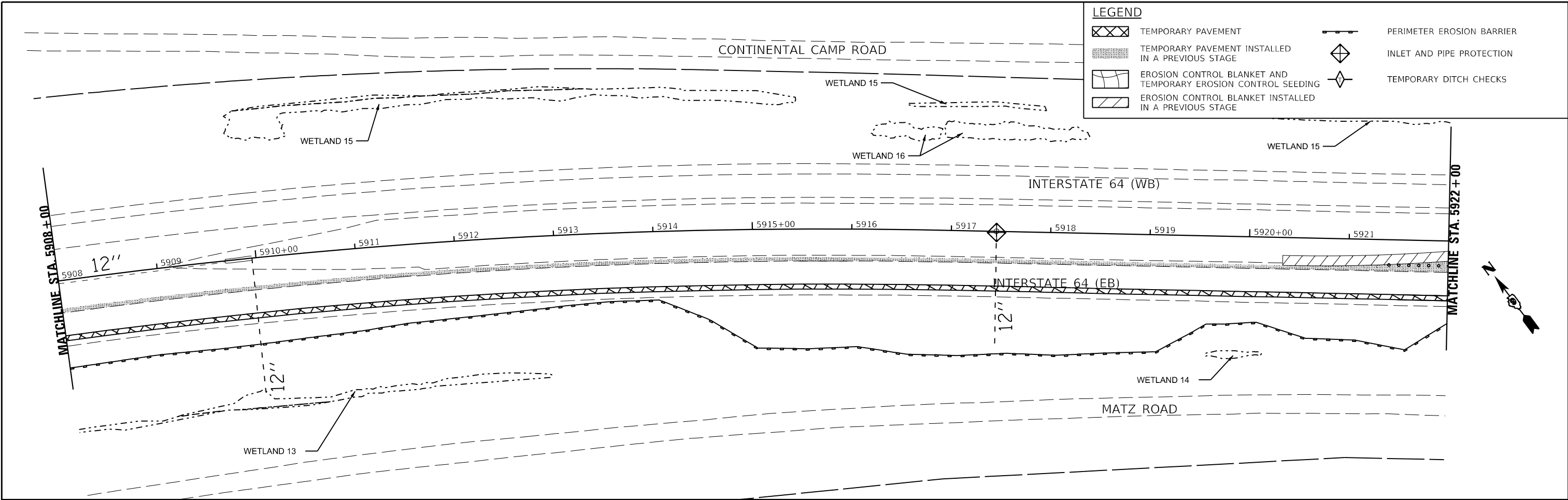

MODEL: 44002\ELNAMES
 FILE: M:\44002\CAD\Drawings\Erosion_Control\PreStage_02\0918307-eh-ec-prestage_2.dwg

KNIGHT
Engineers & Architects

USER NAME = USRA706046	DESIGNED - JS	REVISED - 11/15/2023
PLOT SCALE = 1:100	DRAWN - RTA	REVISED -
PLOT DATE = 11/10/2023	CHECKED - JCM	REVISED -
	DATE - 08/11/2023	REVISED -

**STATE OF ILLINOIS
DEPARTMENT OF TRANSPORTATION**

EROSION CONTROL - PRESTAGE 2			
I-64			
SCALE:	SHEET EC-7 OF 23 SHEETS	STA.	TO STA.

F.A.I. RTE.	SECTION	COUNTY	TOTAL SHEETS	SHEET NO.
64	(97-2) B-5	WHITE	578	139
CONTRACT NO. 78057				
ILLINOIS FED. AID PROJECT FAI 64/WABASH RIVER				

LEGEND

	TEMPORARY PAVEMENT		PERIMETER EROSION BARRIER
	TEMPORARY PAVEMENT INSTALLED IN A PREVIOUS STAGE		INLET AND PIPE PROTECTION
	EROSION CONTROL BLANKET AND TEMPORARY EROSION CONTROL SEEDING		TEMPORARY DITCH CHECKS
	EROSION CONTROL BLANKET INSTALLED IN A PREVIOUS STAGE		

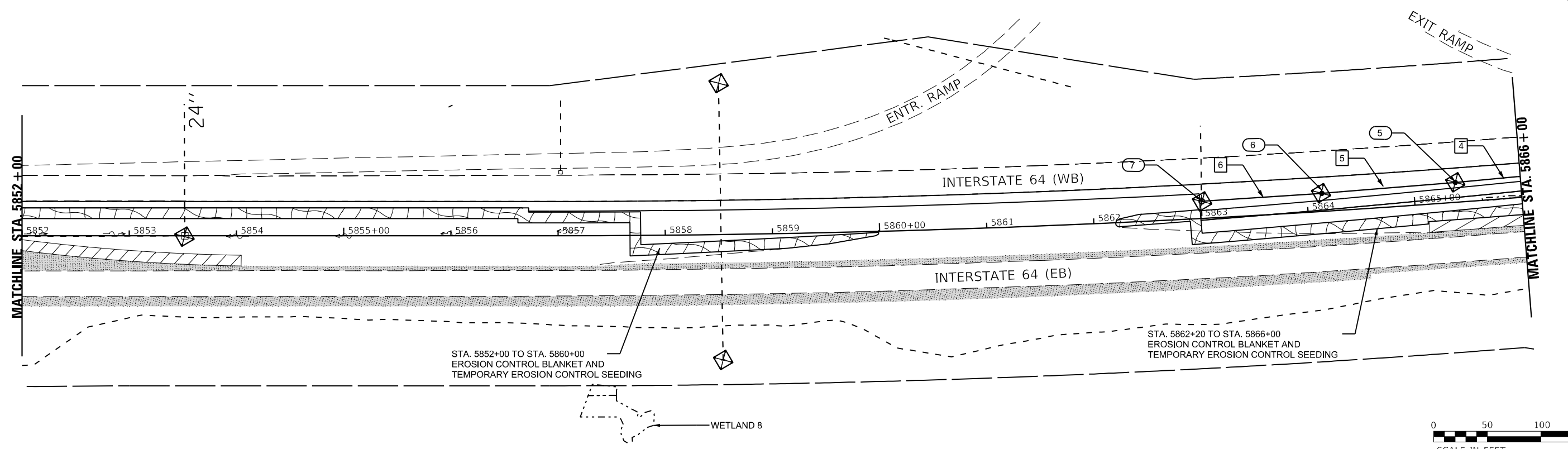
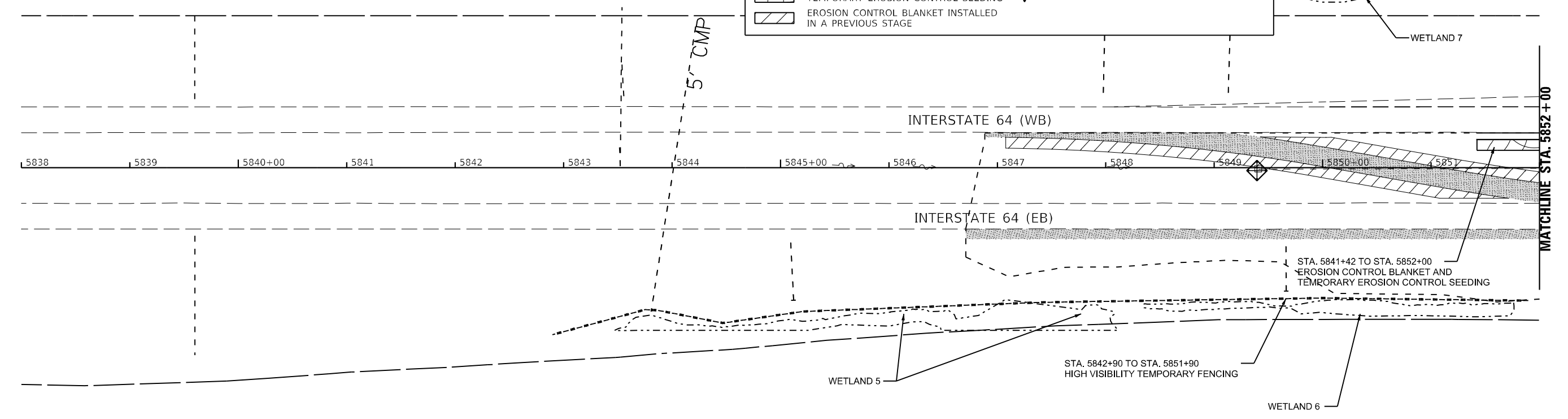

MODEL: I:\MODELS\NAMEX
 FILE NAME: I:\7660\CAD\Drawings\Erosion_Control\Stage_1\0978507241-erosion-control-stage_1-01.dwg

KNIGHT
Engineers & Architects







USER NAME = USRA706046	DESIGNED - JS	REVISED - 11/15/2023
PLOT SCALE = 1:100	DRAWN - RTA	REVISED -
PLOT DATE = 11/10/2023	CHECKED - JCM	REVISED -
	DATE - 08/11/2023	REVISED -

**STATE OF ILLINOIS
DEPARTMENT OF TRANSPORTATION**

EROSION CONTROL - STAGE 1	
I-64	
SCALE:	SHEET EC-8 OF 23 SHEETS STA. TO STA.

F.A.I. RTE.	SECTION	COUNTY	TOTAL SHEETS	SHEET NO.
64	(97-2) B-5	WHITE	578	140
CONTRACT NO. 78057				
ILLINOIS FED. AID PROJECT FAI 64/WABASH RIVER				

LEGEND

-  TEMPORARY PAVEMENT
-  TEMPORARY PAVEMENT INSTALLED IN A PREVIOUS STAGE
-  EROSION CONTROL BLANKET AND TEMPORARY EROSION CONTROL SEEDING
-  EROSION CONTROL BLANKET INSTALLED IN A PREVIOUS STAGE
-  PERIMETER EROSION BARRIER
-  INLET AND PIPE PROTECTION
-  TEMPORARY DITCH CHECKS

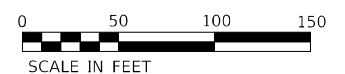
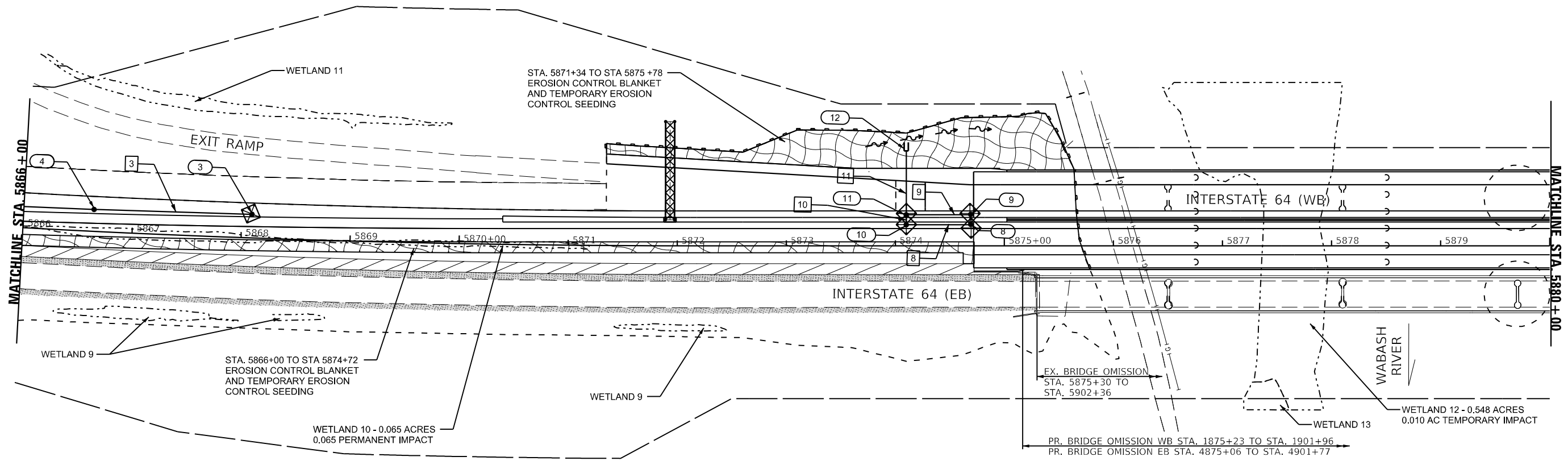

MODEL: I:\MODELS\NAME\...
 FILE: NAME: I:\2023\CAD\Projects\Erosion_Control\Stage_1\09750721-ec-stage_1-02.dwg



USER NAME = USRA706046	DESIGNED - JS	REVISED - 11/15/2023
PLOT SCALE = 1:100	DRAWN - RTA	REVISED -
PLOT DATE = 11/10/2023	CHECKED - JCM	REVISED -
	DATE - 08/11/2023	REVISED -







**STATE OF ILLINOIS
DEPARTMENT OF TRANSPORTATION**

**EROSION CONTROL - STAGE 1
I-64**

SCALE: SHEET EC-9 OF 23 SHEETS STA. TO STA.

F.A.I. RTE.	SECTION	COUNTY	TOTAL SHEETS	SHEET NO.
64	(97-2) B-5	WHITE	578	141
CONTRACT NO. 78057				
ILLINOIS FED. AID PROJECT FAI 64/WABASH RIVER				

LEGEND

-  TEMPORARY PAVEMENT
-  TEMPORARY PAVEMENT INSTALLED IN A PREVIOUS STAGE
-  EROSION CONTROL BLANKET AND TEMPORARY EROSION CONTROL SEEDING
-  EROSION CONTROL BLANKET INSTALLED IN A PREVIOUS STAGE
-  PERIMETER EROSION BARRIER
-  INLET AND PIPE PROTECTION
-  TEMPORARY DITCH CHECKS

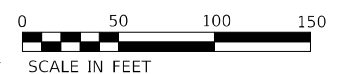
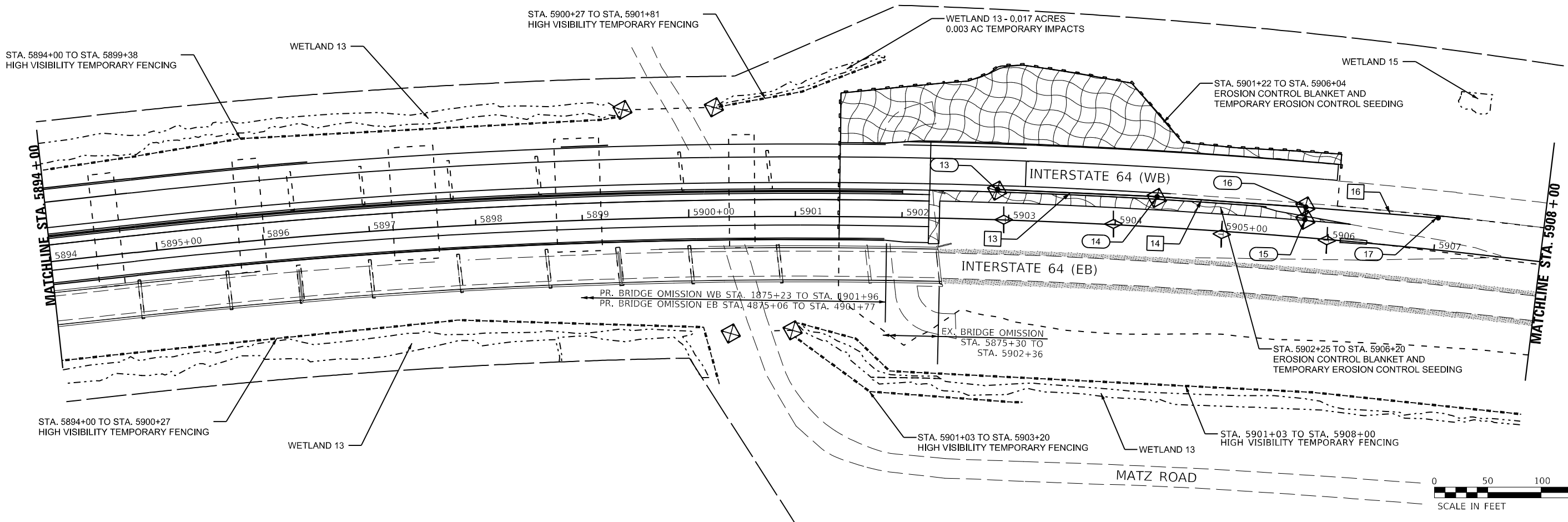
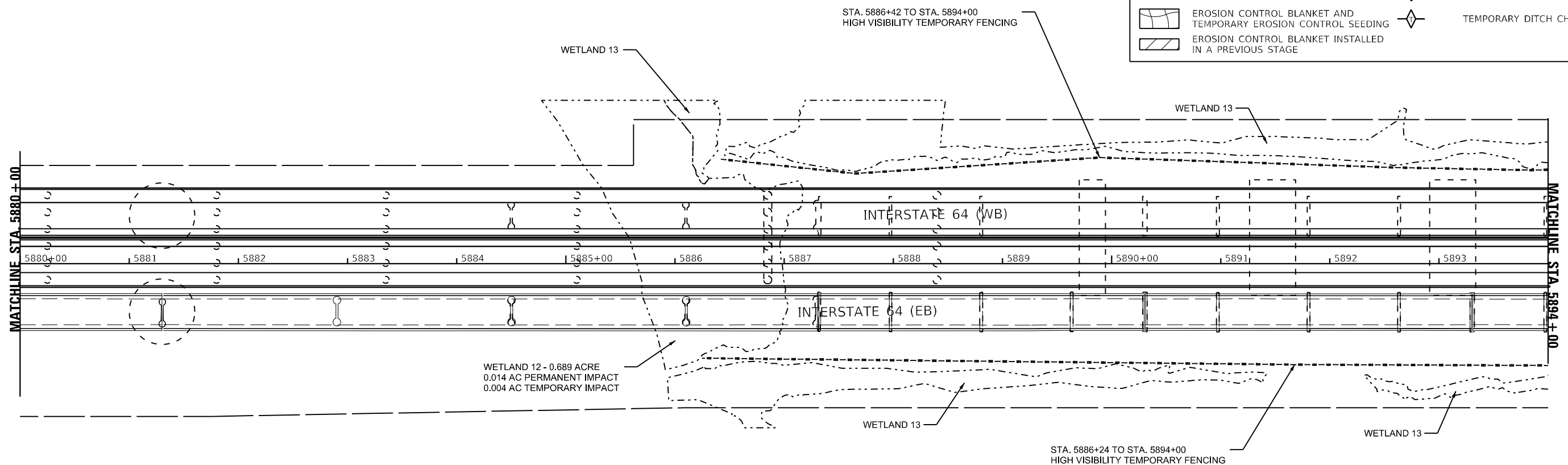

MODEL: 440021ENR.MXD
FILE: M:\MEL_121650\CAD\Projects\Erosion Control\Stage 1\0927507241-erosion-control-stage_1-03.dwg



USER NAME = USRA706046	DESIGNED - JS	REVISED - 11/15/2023
PLOT SCALE = 1:100	DRAWN - RTA	REVISED -
PLOT DATE = 11/10/2023	CHECKED - JCM	REVISED -
	DATE - 08/11/2023	REVISED -

**STATE OF ILLINOIS
DEPARTMENT OF TRANSPORTATION**

**EROSION CONTROL - STAGE 1
I-64**

SCALE: SHEET EC-10 OF 23 SHEETS STA. TO STA.

F.A.I. RTE.	SECTION	COUNTY	TOTAL SHEETS	SHEET NO.
64	(97-2) B-5	WHITE	578	142
CONTRACT NO. 78057				
ILLINOIS FED. AID PROJECT FAI 64/WABASH RIVER				

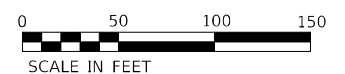
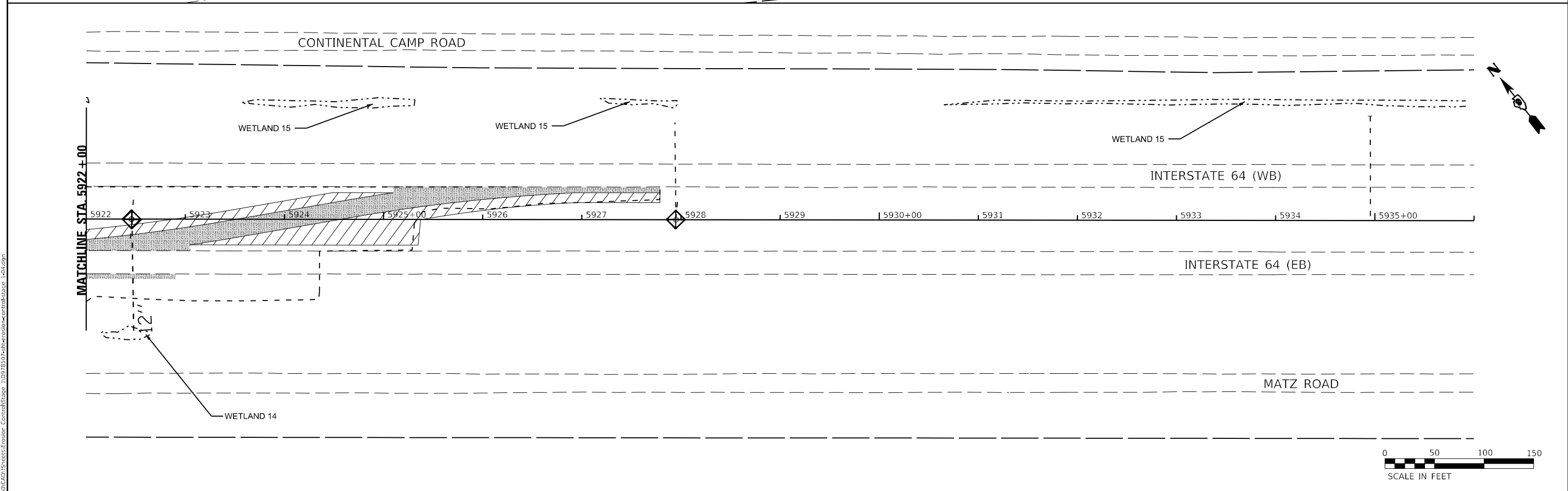
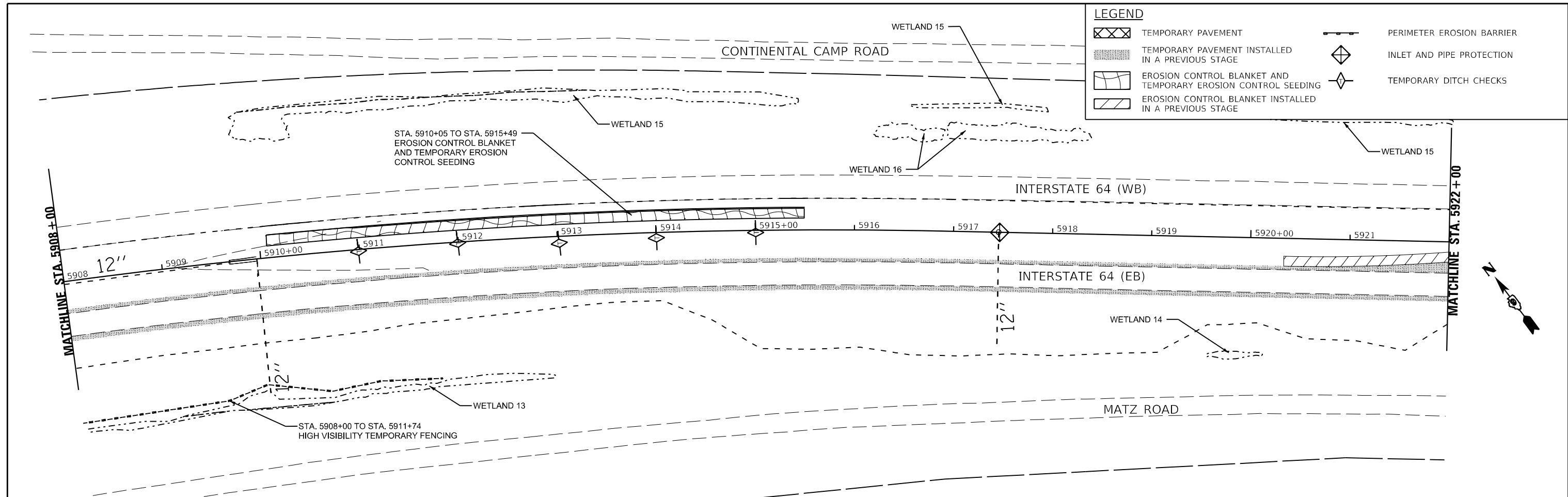

MODEL: \\MODEL\NAME\...
 FILE: \\MODEL\...

KNIGHT
Engineers & Architects

USER NAME = USRA706046	DESIGNED - JS	REVISED - 11/15/2023
PLOT SCALE = 1:100	DRAWN - RTA	REVISED -
PLOT DATE = 11/10/2023	CHECKED - JCM	REVISED -
	DATE - 08/11/2023	REVISED -

**STATE OF ILLINOIS
DEPARTMENT OF TRANSPORTATION**

EROSION CONTROL - STAGE 1	
I-64	
SCALE:	SHEET EC-11 OF 23 SHEETS STA. TO STA.

F.A.I. RTE.	SECTION	COUNTY	TOTAL SHEETS	SHEET NO.
64	(97-2) B-5	WHITE	578	143
CONTRACT NO. 78057				
ILLINOIS FED. AID PROJECT FAI 64/WABASH RIVER				

LEGEND

	TEMPORARY PAVEMENT		PERIMETER EROSION BARRIER
	TEMPORARY PAVEMENT INSTALLED IN A PREVIOUS STAGE		INLET AND PIPE PROTECTION
	EROSION CONTROL BLANKET AND TEMPORARY EROSION CONTROL SEEDING		TEMPORARY DITCH CHECKS
	EROSION CONTROL BLANKET INSTALLED IN A PREVIOUS STAGE		

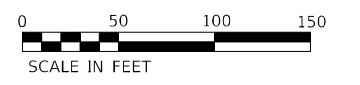
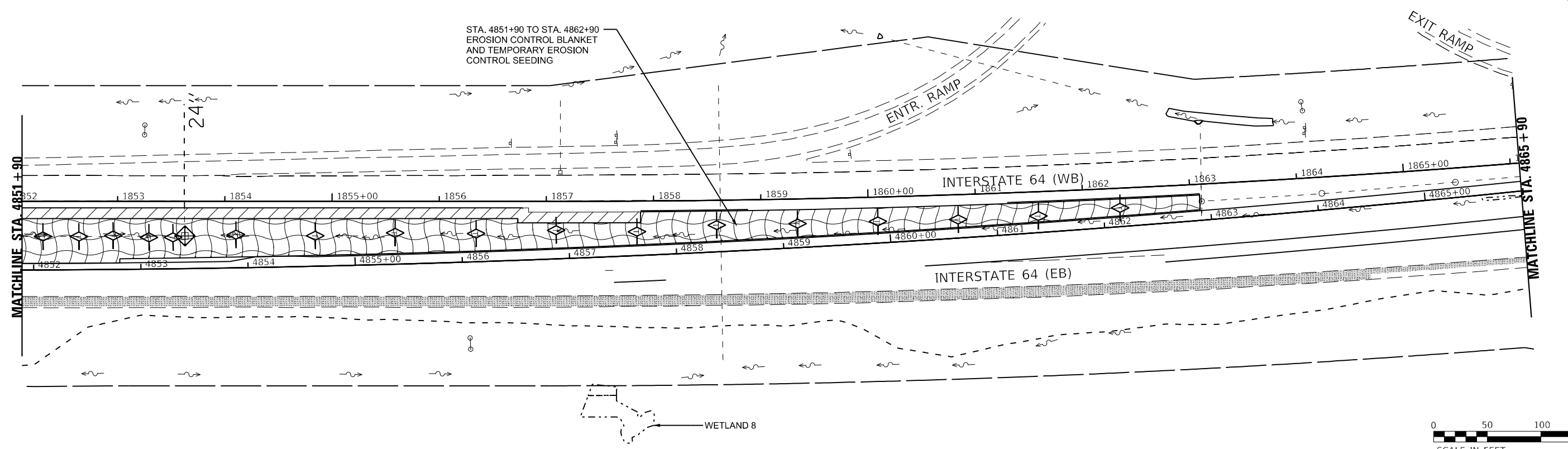
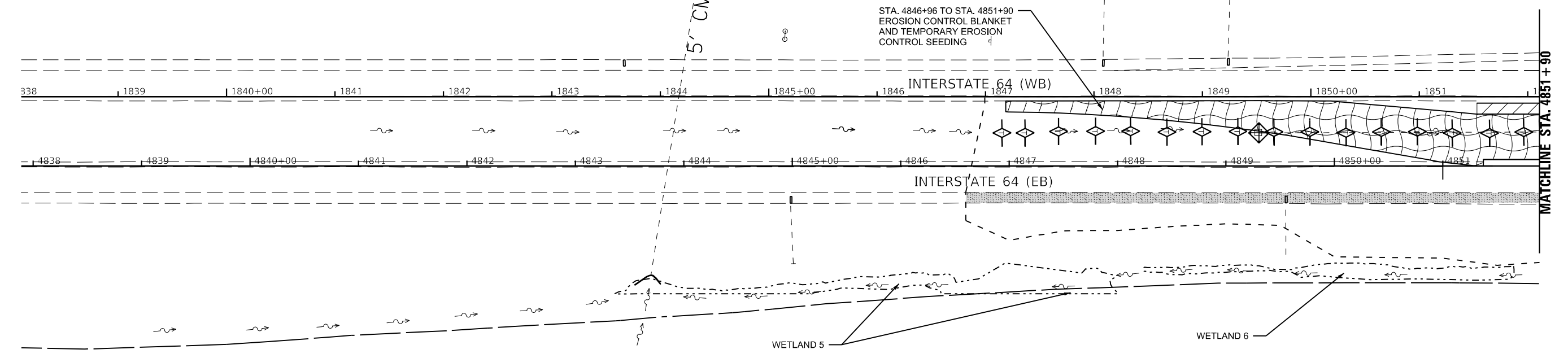

MODEL: I:\MODELS\NAME\...
 FILE NAME: I:\2023\CAD\Projects\Erosion Control\Stage 2\09785072-1-erosion-control-stage-2-01.dwg



USER NAME = USRA706046	DESIGNED - JS	REVISED - 11/15/2023
DRAWN - RTA	REVISIONS -	
CHECKED - JCM	REVISIONS -	
DATE - 08/11/2023	REVISIONS -	
PLOT SCALE = 1:100		
PLOT DATE = 11/10/2023		







**STATE OF ILLINOIS
DEPARTMENT OF TRANSPORTATION**

**EROSION CONTROL - STAGE 2
I-64**

SCALE: SHEET EC-12 OF 23 SHEETS STA. TO STA.

F.A.I. RTE.	SECTION	COUNTY	TOTAL SHEETS	SHEET NO.
64	(97-2) B-5	WHITE	578	144
CONTRACT NO. 78057				
ILLINOIS FED. AID PROJECT FAI 64/WABASH RIVER				

LEGEND

-  TEMPORARY PAVEMENT
-  TEMPORARY PAVEMENT INSTALLED IN A PREVIOUS STAGE
-  EROSION CONTROL BLANKET AND TEMPORARY EROSION CONTROL SEEDING
-  EROSION CONTROL BLANKET INSTALLED IN A PREVIOUS STAGE
-  PERIMETER EROSION BARRIER
-  INLET AND PIPE PROTECTION
-  TEMPORARY DITCH CHECKS

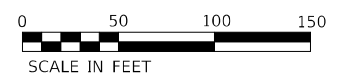
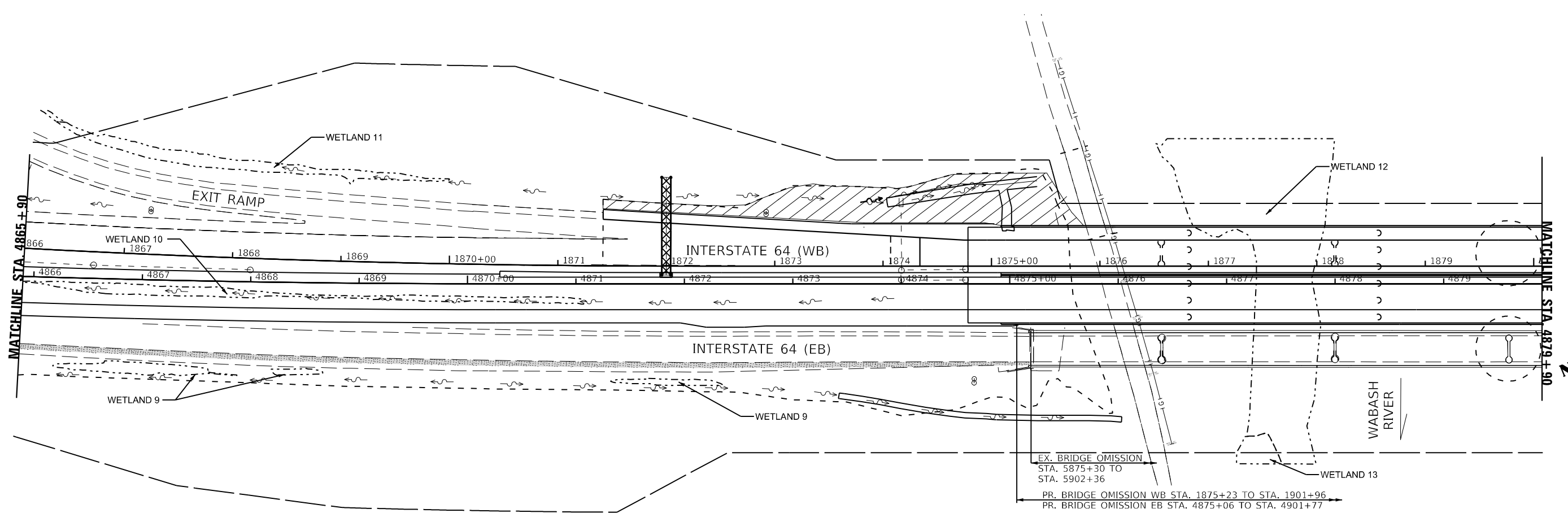

MODEL: I:\MODELS\NAME\ FILE: NAME: I:\2023\CAD\Projects\Erosion_Control\Stage 2\072523\7-11-23-erosion-control-stage_2-02.dwg









USER NAME = USRA706046	DESIGNED - JS	REVISED - 11/15/2023
PLOT SCALE = 1:100	DRAWN - RTA	REVISED -
PLOT DATE = 11/10/2023	CHECKED - JCM	REVISED -
	DATE - 08/11/2023	REVISED -

**STATE OF ILLINOIS
DEPARTMENT OF TRANSPORTATION**

EROSION CONTROL - STAGE 2		
I-64		
SCALE:	SHEET EC-13 OF 23 SHEETS	STA. TO STA.

F.A.I. RTE.	SECTION	COUNTY	TOTAL SHEETS	SHEET NO.
64	(97-2) B-5	WHITE	578	145
CONTRACT NO. 78057				
ILLINOIS FED. AID PROJECT FAI 64/WABASH RIVER				

LEGEND

-  TEMPORARY PAVEMENT
-  TEMPORARY PAVEMENT INSTALLED IN A PREVIOUS STAGE
-  EROSION CONTROL BLANKET AND TEMPORARY EROSION CONTROL SEEDING
-  EROSION CONTROL BLANKET INSTALLED IN A PREVIOUS STAGE
-  PERIMETER EROSION BARRIER
-  INLET AND PIPE PROTECTION
-  TEMPORARY DITCH CHECKS

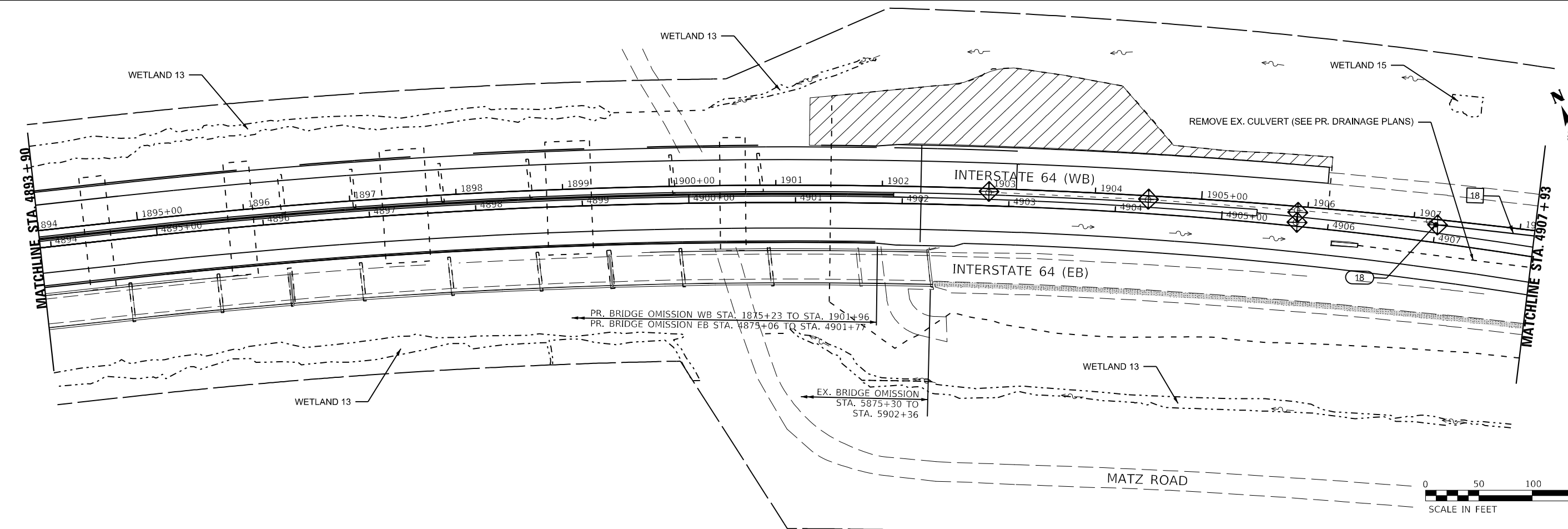
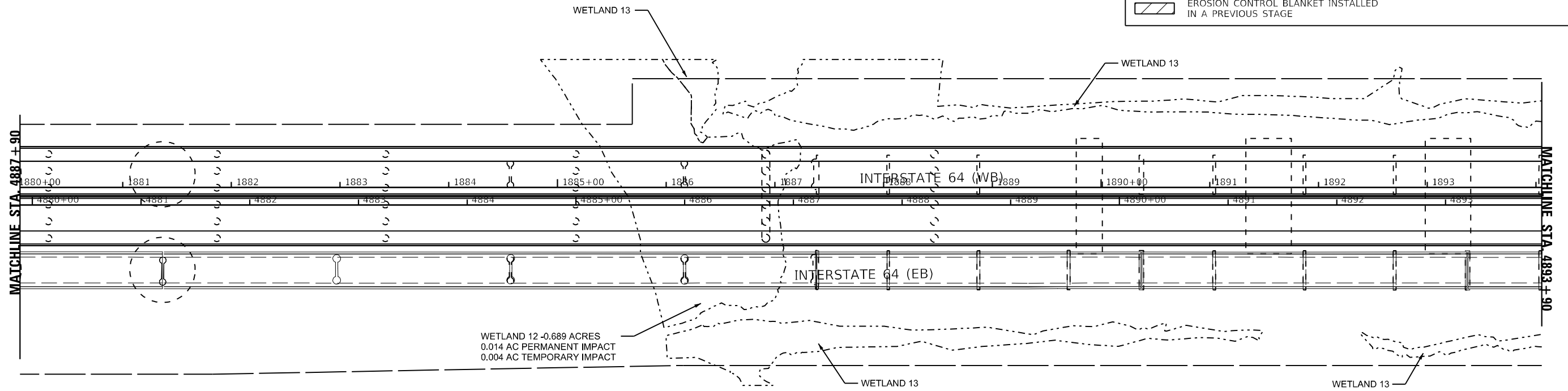

MODEL: 440021ENR.MXD
FILE NAME: L:\2023\CAD\Projects\Erosion Control\Stage 2\09785072-11-erosion-control-stage 2-03.dwg

KNIGHT Engineers & Architects	USER NAME = USRA706046	DESIGNED - JS	REVISED - 11/15/2023
	PLOT SCALE = 1:100	DRAWN - RTA	REVISED -
	PLOT DATE = 11/10/2023	CHECKED - JCM	REVISED -
		DATE - 08/11/2023	REVISED -







**STATE OF ILLINOIS
DEPARTMENT OF TRANSPORTATION**

**EROSION CONTROL - STAGE 2
I-64**

SCALE: SHEET EC-14 OF 23 SHEETS STA. TO STA.

F.A.I. RTE.	SECTION	COUNTY	TOTAL SHEETS	SHEET NO.
64	(97-2) B-5	WHITE	578	146
CONTRACT NO. 78057				
ILLINOIS FED. AID PROJECT FAI 64/WABASH RIVER				

LEGEND

-  TEMPORARY PAVEMENT
-  TEMPORARY PAVEMENT INSTALLED IN A PREVIOUS STAGE
-  EROSION CONTROL BLANKET AND TEMPORARY EROSION CONTROL SEEDING
-  EROSION CONTROL BLANKET INSTALLED IN A PREVIOUS STAGE
-  PERIMETER EROSION BARRIER
-  INLET AND PIPE PROTECTION
-  TEMPORARY DITCH CHECKS

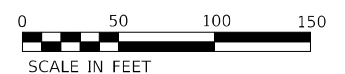
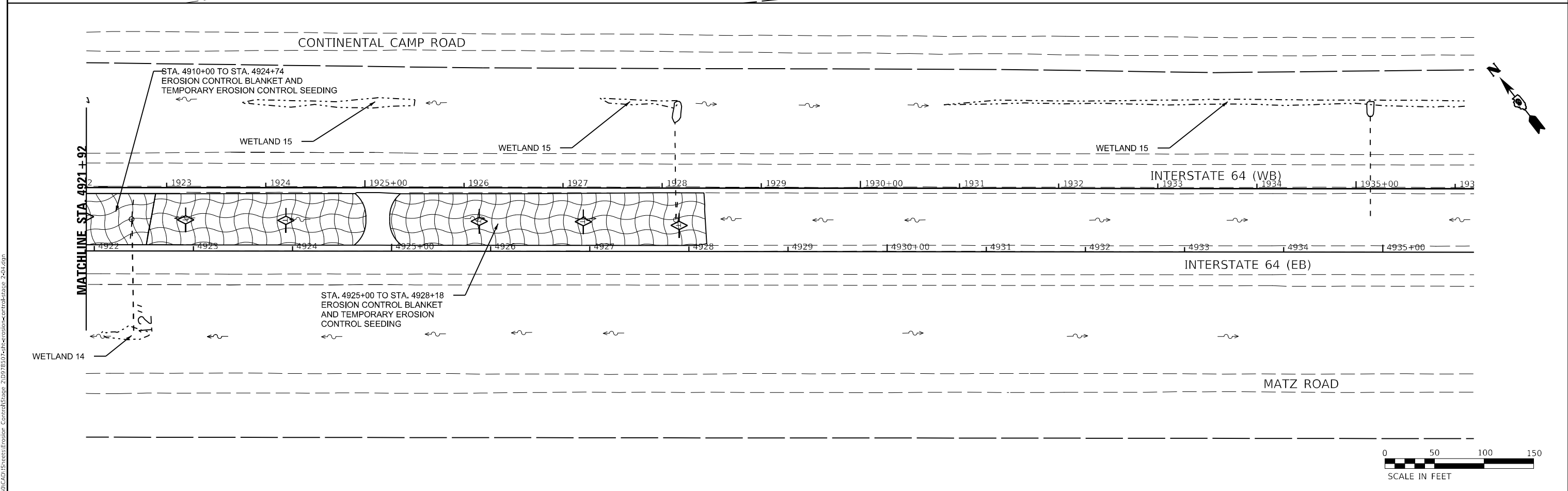
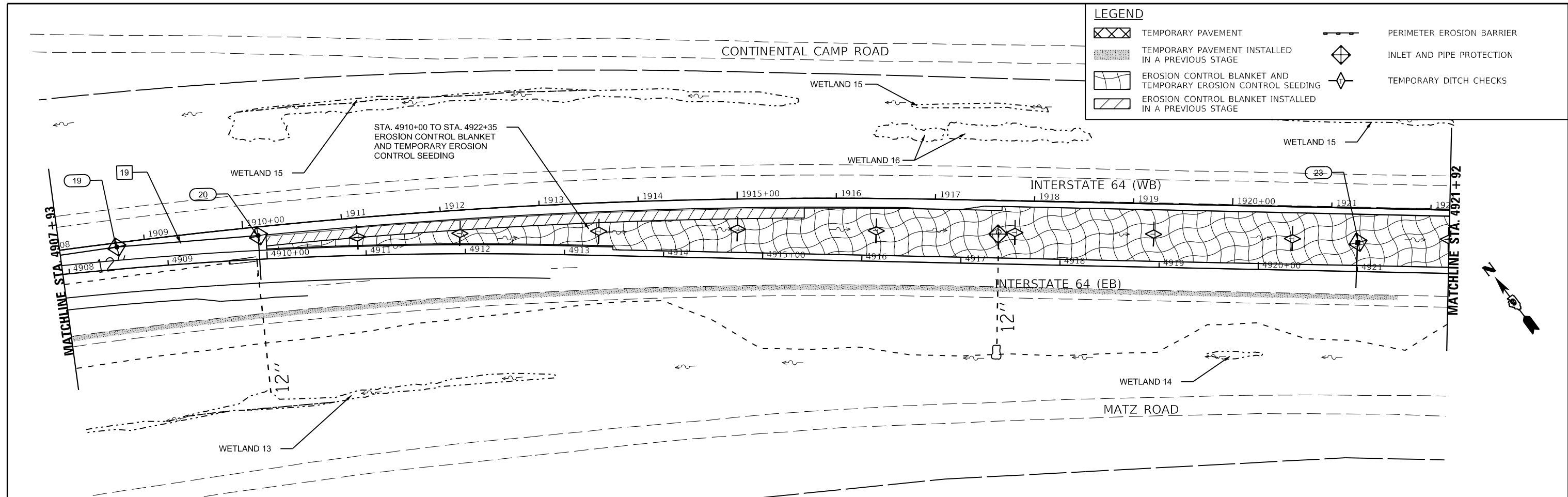

MODEL: 44002\BENAMES
FILE: MAMEL: 117650\CAD\Projects\Erosion Control\Stage 2\0978507-2-11-erosion-control-stage-2-04.dwg



USER NAME = USRA706046	DESIGNED - JS	REVISED - 11/15/2023
PLOT SCALE = 1:100	DRAWN - RTA	REVISED -
PLOT DATE = 11/10/2023	CHECKED - JCM	REVISED -
	DATE - 08/11/2023	REVISED -

**STATE OF ILLINOIS
DEPARTMENT OF TRANSPORTATION**

EROSION CONTROL - STAGE 2		
I-64		
SCALE:	SHEET EC-15 OF 23 SHEETS	STA. TO STA.

F.A.I. RTE.	SECTION	COUNTY	TOTAL SHEETS	SHEET NO.
64	(97-2) B-5	WHITE	578	147
CONTRACT NO. 78057				
ILLINOIS FED. AID PROJECT FAI 64/WABASH RIVER				

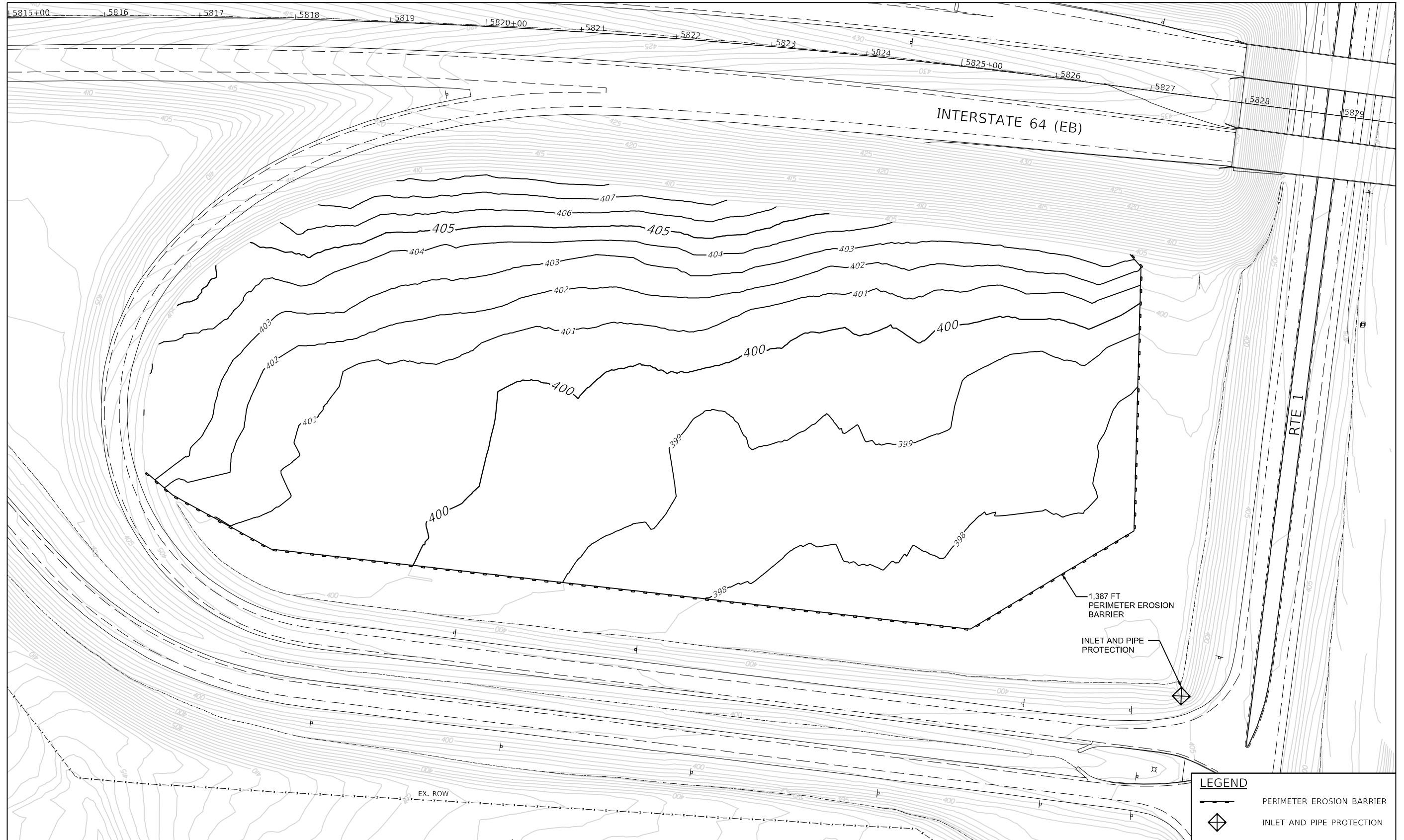

LEGEND

— PERIMETER EROSION BARRIER

◊ INLET AND PIPE PROTECTION

- NOTES:**
1. PLACE EROSION CONTROL BLANKET ON EXPOSED EARTH WITHIN GRADING AREA (44,000 SQ YD)
 2. AFTER GRADING, SEED ALL DISTURBED AREAS WITH SEEDING, CLASS 2A (9.1 ACRES)

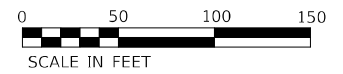

MODEL: 4400ERLNAME
 FILE NAME: L:\1600\ICAD\Projects\Erosion Control\Stage 2\078507-2-11-erosion-control-stage 2-05.dwg

KNIGHT Engineers & Architects	USER NAME = US15706126	DESIGNED - JS	REVISED - 11/15/2023
	PLOT SCALE = 1:100	DRAWN - RTA	REVISED -
	PLOT DATE = 11/14/2023	CHECKED - JCM	REVISED -
		DATE - 08/11/2023	REVISED -







STATE OF ILLINOIS
DEPARTMENT OF TRANSPORTATION

EROSION CONTROL – STAGE 2
I-64

SCALE: SHEET EC-16 OF 23 SHEETS STA. TO STA.

F.A.I. RTE.	SECTION	COUNTY	TOTAL SHEETS	SHEET NO.
64	(97-2) B-5	WHITE	578	148
CONTRACT NO. 78057				
ILLINOIS FED. AID PROJECT FAI 64/WABASH RIVER				

LEGEND

	TEMPORARY PAVEMENT		PERIMETER EROSION BARRIER
	TEMPORARY PAVEMENT INSTALLED IN A PREVIOUS STAGE		INLET AND PIPE PROTECTION
	EROSION CONTROL BLANKET AND TEMPORARY EROSION CONTROL SEEDING		TEMPORARY DITCH CHECKS
	EROSION CONTROL BLANKET INSTALLED IN A PREVIOUS STAGE		

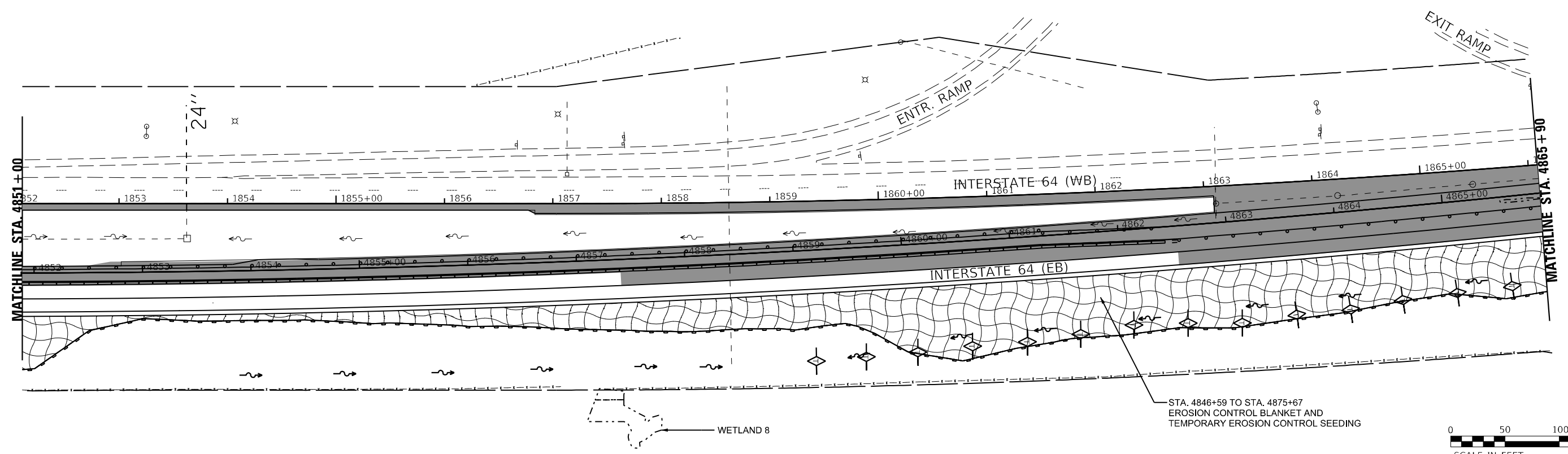
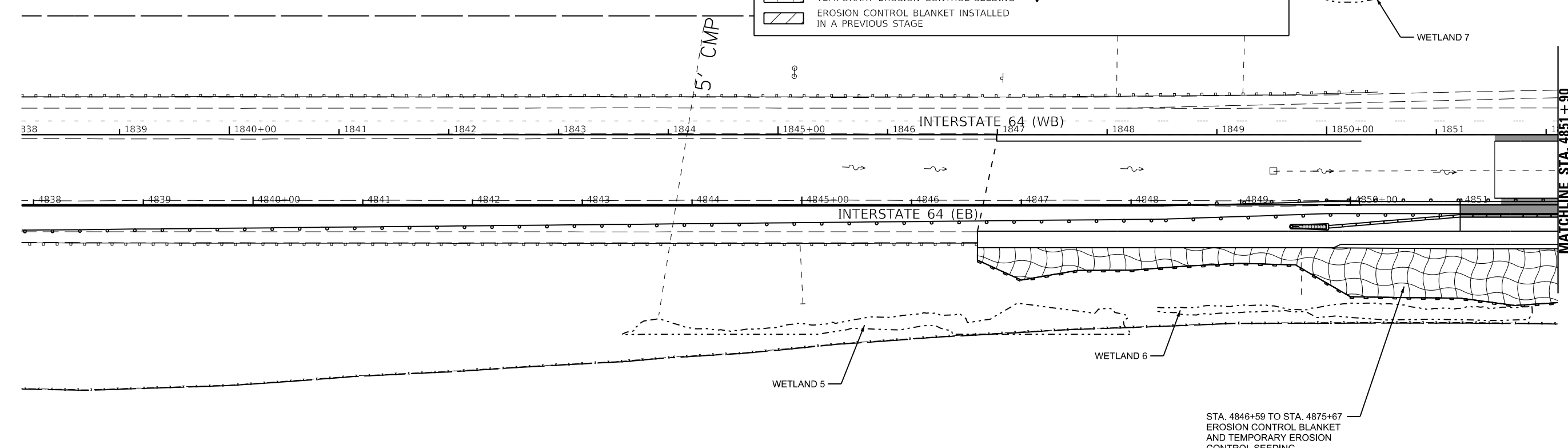

MODEL: \\MODELS\NAMEX
 FILE NAME: \\S:\60\ICAD\Projects\Erosion Control\Stage 3\09785072-eh-erosion-control-stage 3-01.dwg



USER NAME = USRA706046	DESIGNED - JS	REVISED - 11/15/2023
PLOT SCALE = 1:100	DRAWN - RTA	REVISED -
PLOT DATE = 11/10/2023	CHECKED - JCM	REVISED -
	DATE - 08/11/2023	REVISED -







**STATE OF ILLINOIS
DEPARTMENT OF TRANSPORTATION**

**EROSION CONTROL - STAGE 3
I-64**

SCALE: SHEET EC-17 OF 23 SHEETS STA. TO STA.

F.A.I. RTE.	SECTION	COUNTY	TOTAL SHEETS	SHEET NO.
64	(97-2) B-5	WHITE	578	149
CONTRACT NO. 78057				
ILLINOIS FED. AID PROJECT FAI 64/WABASH RIVER				

LEGEND

-  TEMPORARY PAVEMENT
-  TEMPORARY PAVEMENT INSTALLED IN A PREVIOUS STAGE
-  EROSION CONTROL BLANKET AND TEMPORARY EROSION CONTROL SEEDING
-  EROSION CONTROL BLANKET INSTALLED IN A PREVIOUS STAGE
-  PERIMETER EROSION BARRIER
-  INLET AND PIPE PROTECTION
-  TEMPORARY DITCH CHECKS

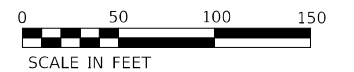
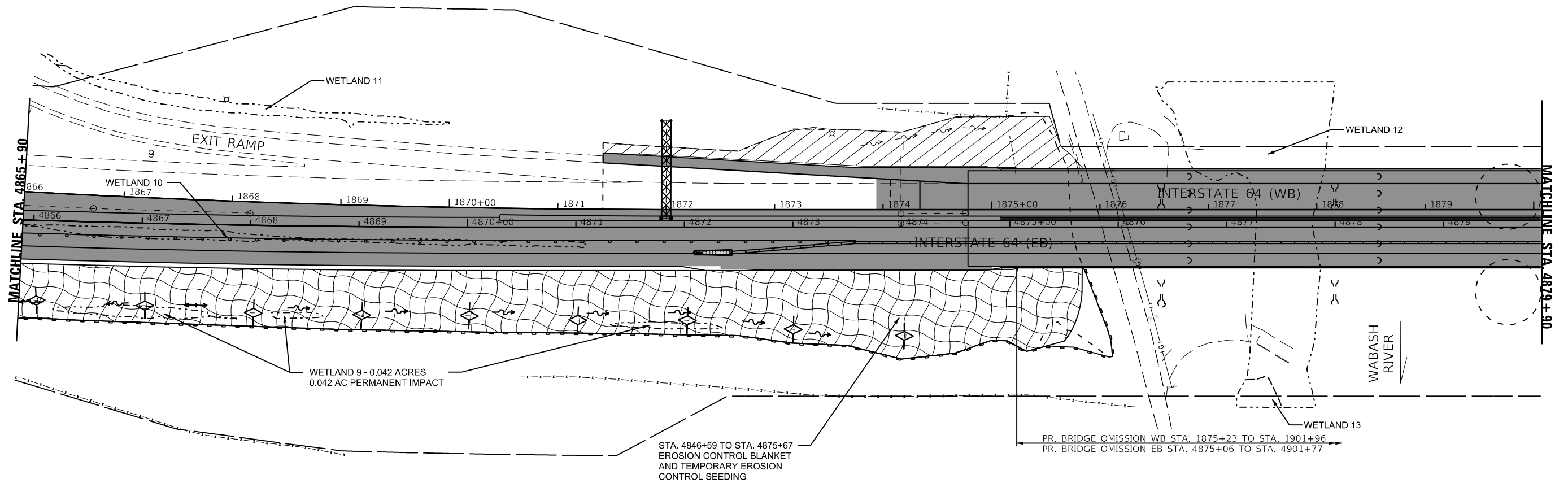

MODEL: I:\MODELS\NAME\ FILE: NAME: I:\2023\CAD\Projects\Erosion_Control\Stage_3\09750721-ec-erosion-control-stage_3-02.dwg

KNIGHT
Engineers & Architects

USER NAME = USRA706046	DESIGNED - JS	REVISED - 11/15/2023
PLOT SCALE = 1:100	DRAWN - RTA	REVISED -
PLOT DATE = 11/10/2023	CHECKED - JCM	REVISED -
	DATE - 08/11/2023	REVISED -

**STATE OF ILLINOIS
DEPARTMENT OF TRANSPORTATION**

**EROSION CONTROL - STAGE 3
I-64**

SCALE: SHEET EC-18 OF 23 SHEETS STA. TO STA.

F.A.I. RTE.	SECTION	COUNTY	TOTAL SHEETS	SHEET NO.
64	(97-2) B-5	WHITE	578	150
CONTRACT NO. 78057				
ILLINOIS FED. AID PROJECT FAI 64/WABASH RIVER				

LEGEND			
	TEMPORARY PAVEMENT		PERIMETER EROSION BARRIER
	TEMPORARY PAVEMENT INSTALLED IN A PREVIOUS STAGE		INLET AND PIPE PROTECTION
	EROSION CONTROL BLANKET AND TEMPORARY EROSION CONTROL SEEDING		TEMPORARY DITCH CHECKS
	EROSION CONTROL BLANKET INSTALLED IN A PREVIOUS STAGE		

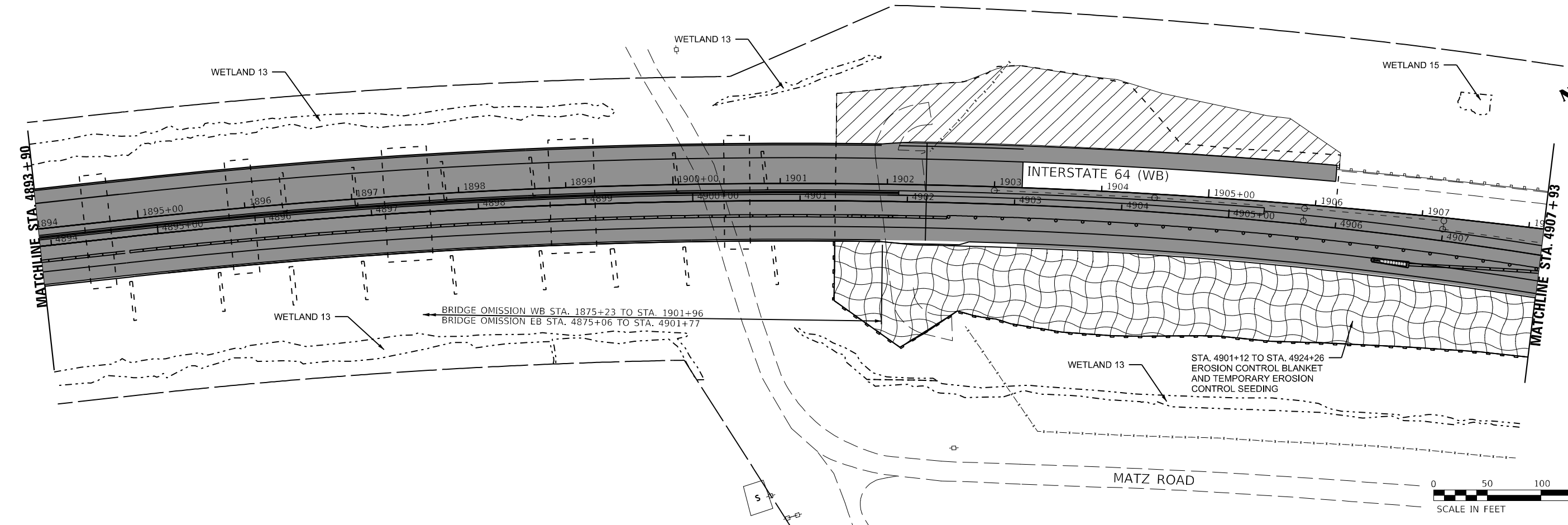
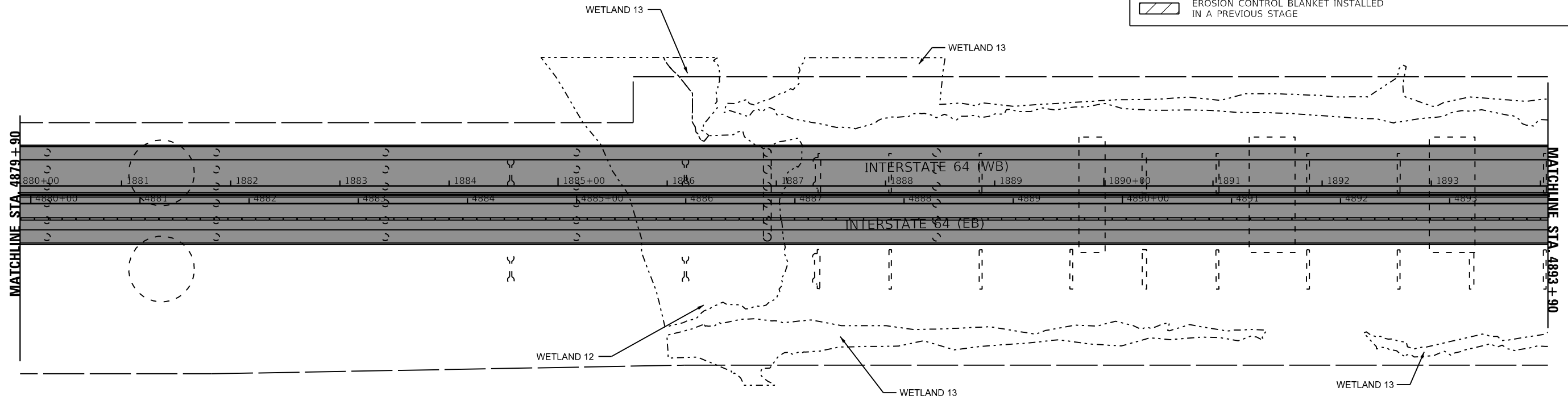

MODEL: 44002\BENAMES FILE: NAME: 121650\CAD\Projects\Erosion Control\Stage 3\09785072-eh-erosion-control-stage-3-03.dwg

KNIGHT
Engineers & Architects







USER NAME = USRA706046	DESIGNED - JS	REVISED - 11/15/2023
PLOT SCALE = 1:100	DRAWN - RTA	REVISED -
PLOT DATE = 11/10/2023	CHECKED - JCM	REVISED -
	DATE - 08/11/2023	REVISED -

**STATE OF ILLINOIS
DEPARTMENT OF TRANSPORTATION**

EROSION CONTROL - STAGE 3	
I-64	
SCALE:	SHEET EC-19 OF 23 SHEETS STA. TO STA.

F.A.I. RTE.	SECTION	COUNTY	TOTAL SHEETS	SHEET NO.
64	(97-2) B-5	WHITE	578	151
CONTRACT NO. 78057				
ILLINOIS FED. AID PROJECT FAI 64/WABASH RIVER				

LEGEND

-  TEMPORARY PAVEMENT
-  TEMPORARY PAVEMENT INSTALLED IN A PREVIOUS STAGE
-  EROSION CONTROL BLANKET AND TEMPORARY EROSION CONTROL SEEDING
-  EROSION CONTROL BLANKET INSTALLED IN A PREVIOUS STAGE
-  PERIMETER EROSION BARRIER
-  INLET AND PIPE PROTECTION
-  TEMPORARY DITCH CHECKS

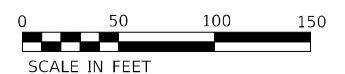
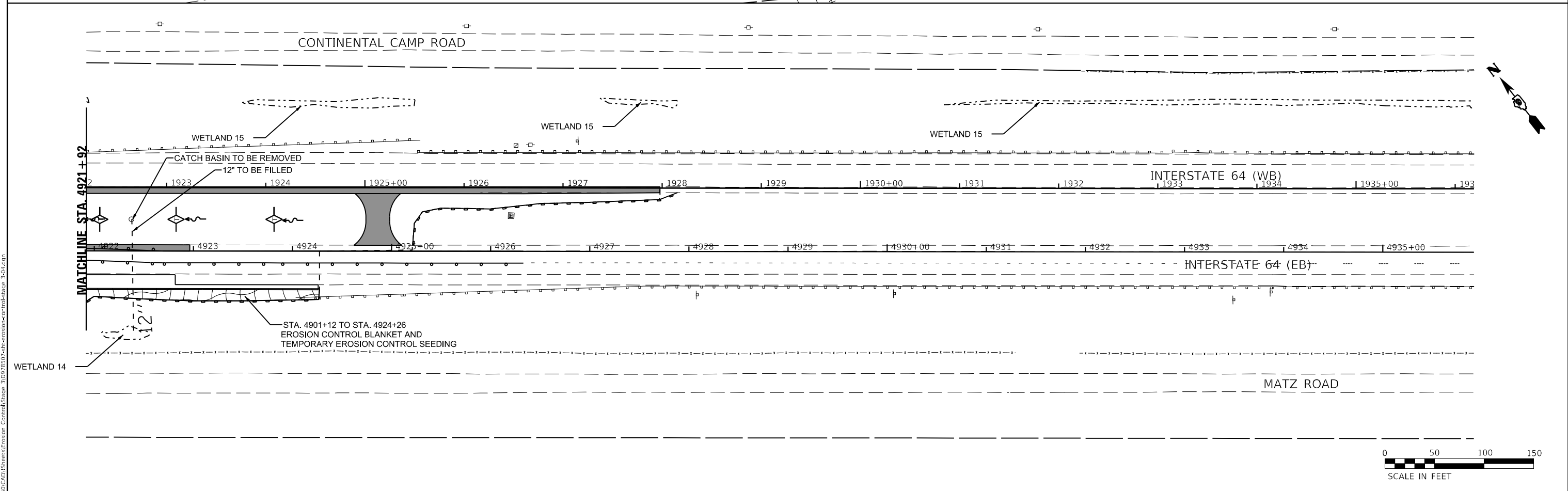
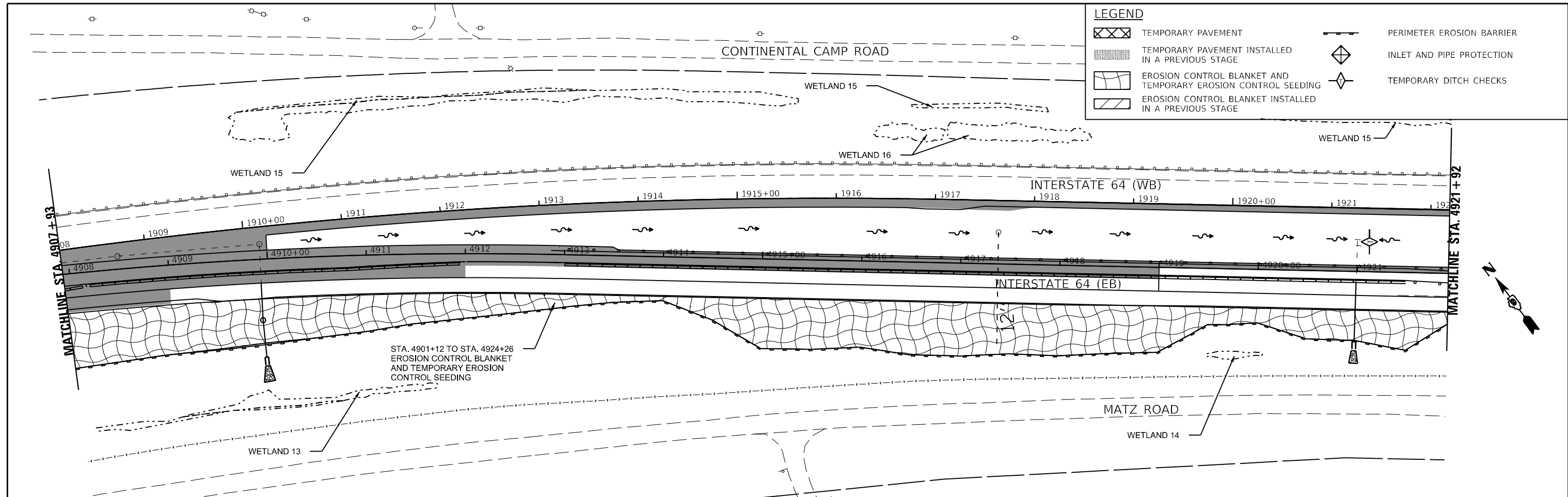

MODEL: I:\MODELS\NAME\...
FILE: NAME: I:\MODELS\NAME\...-erosion-control-stage-3.dwg

KNIGHT
Engineers & Architects

USER NAME = USRA706046	DESIGNED - JS	REVISED - 11/15/2023
PLOT SCALE = 1:100	DRAWN - RTA	REVISED -
PLOT DATE = 11/10/2023	CHECKED - JCM	REVISED -
	DATE - 08/11/2023	REVISED -

**STATE OF ILLINOIS
DEPARTMENT OF TRANSPORTATION**

EROSION CONTROL - STAGE 3			
I-64			
SCALE:	SHEET EC-20 OF 23 SHEETS	STA.	TO STA.

F.A.I. RTE.	SECTION	COUNTY	TOTAL SHEETS	SHEET NO.
64	(97-2) B-5	WHITE	578	152
CONTRACT NO. 78057				
ILLINOIS FED. AID PROJECT FAI 64/WABASH RIVER				

LEGEND

	TEMPORARY PAVEMENT		PERIMETER EROSION BARRIER
	TEMPORARY PAVEMENT INSTALLED IN A PREVIOUS STAGE		INLET AND PIPE PROTECTION
	EROSION CONTROL BLANKET AND TEMPORARY EROSION CONTROL SEEDING		TEMPORARY DITCH CHECKS
	EROSION CONTROL BLANKET INSTALLED IN A PREVIOUS STAGE		

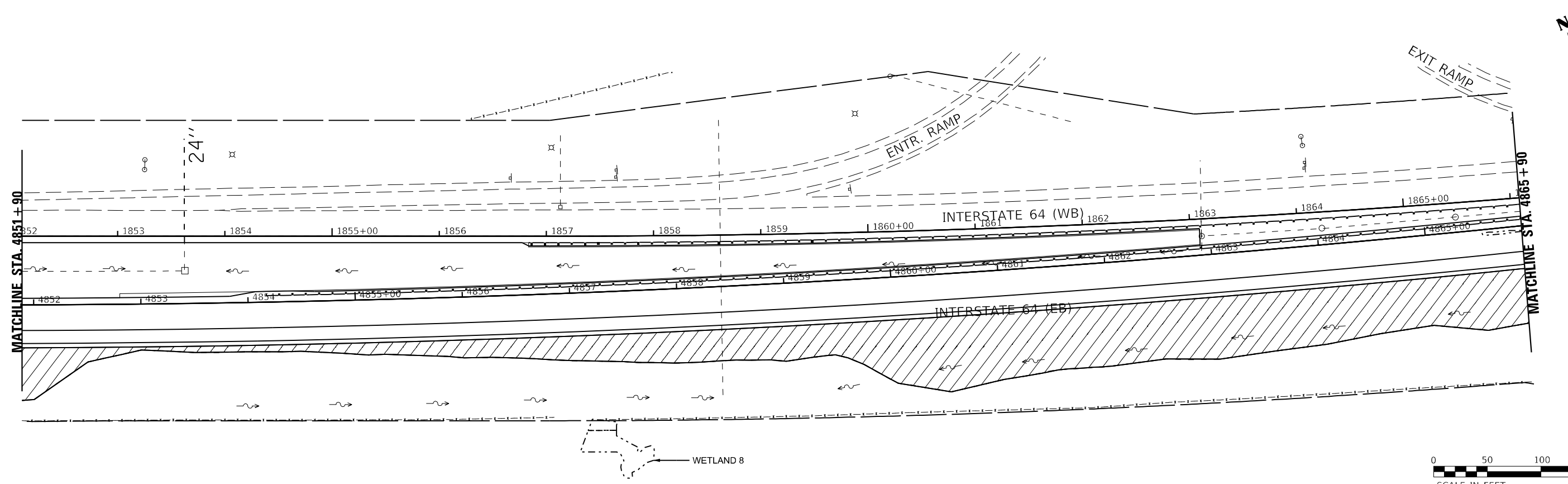
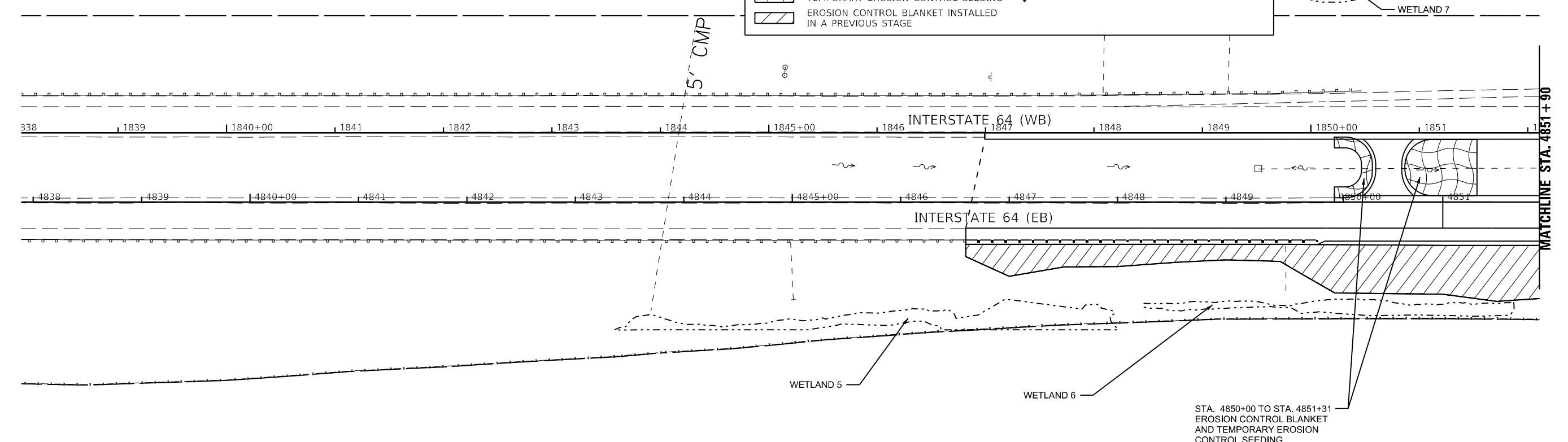

MODEL: I:\MODELS\NAMEX
 FILE NAME: I:\2023\CD\US\sect4\erosion_control\stage_401.dwg



USER NAME = USRA706046	DESIGNED - JS	REVISED - 11/15/2023
DRAWN - RTA	REVISOR -	
CHECKED - JCM	REVISOR -	
DATE - 08/11/2023	REVISOR -	
PLOT SCALE = 1:100		
PLOT DATE = 11/10/2023		







**STATE OF ILLINOIS
DEPARTMENT OF TRANSPORTATION**

**EROSION CONTROL - STAGE 4
I-64**

SCALE: SHEET EC-21 OF 23 SHEETS STA. TO STA.

F.A.I. RTE.	SECTION	COUNTY	TOTAL SHEETS	SHEET NO.
64	(97-2) B-5	WHITE	578	153
CONTRACT NO. 78057				
ILLINOIS FED. AID PROJECT FAI 64/WABASH RIVER				

LEGEND

-  TEMPORARY PAVEMENT
-  TEMPORARY PAVEMENT INSTALLED IN A PREVIOUS STAGE
-  EROSION CONTROL BLANKET AND TEMPORARY EROSION CONTROL SEEDING
-  EROSION CONTROL BLANKET INSTALLED IN A PREVIOUS STAGE
-  PERIMETER EROSION BARRIER
-  INLET AND PIPE PROTECTION
-  TEMPORARY DITCH CHECKS

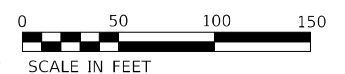
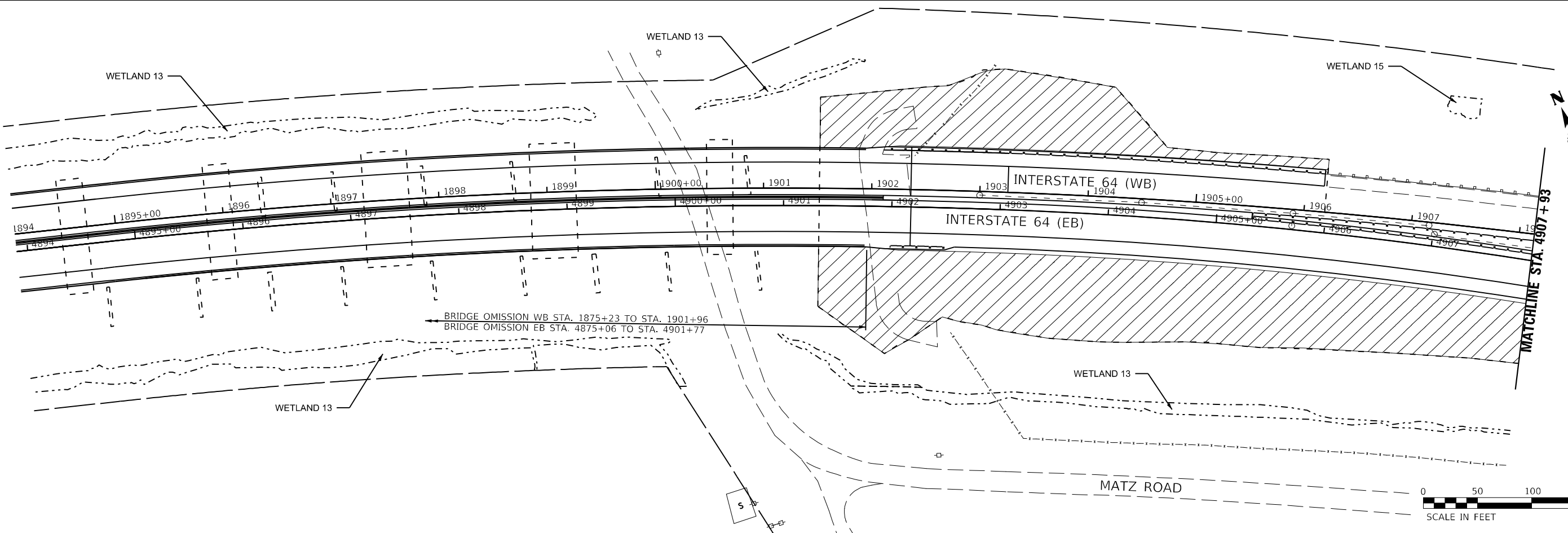
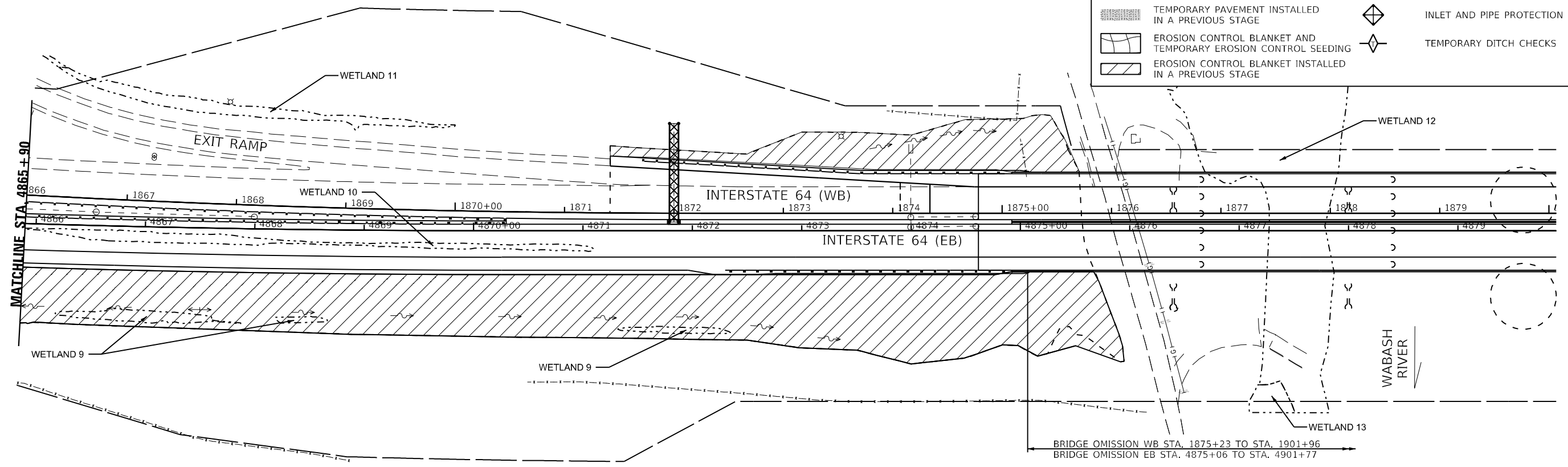

MODEL: I:\MODELS\NAME\...
FILE: NAME: I:\MODELS\NAME\...
CONTRACT: 78057

KNIGHT
Engineers & Architects

USER NAME = USRA706046	DESIGNED - JS	REVISED - 11/15/2023
PLOT SCALE = 1:100	DRAWN - RTA	REVISED -
PLOT DATE = 11/10/2023	CHECKED - JCM	REVISED -
	DATE - 08/11/2023	REVISED -

**STATE OF ILLINOIS
DEPARTMENT OF TRANSPORTATION**

EROSION CONTROL - STAGE 4	
I-64	
SCALE:	SHEET EC-22 OF 23 SHEETS STA. TO STA.

F.A.I. RTE.	SECTION	COUNTY	TOTAL SHEETS	SHEET NO.
64	(97-2) B-5	WHITE	578	154
CONTRACT NO. 78057				
ILLINOIS FED. AID PROJECT FAI 64/WABASH RIVER				

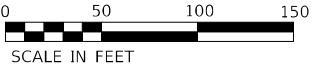
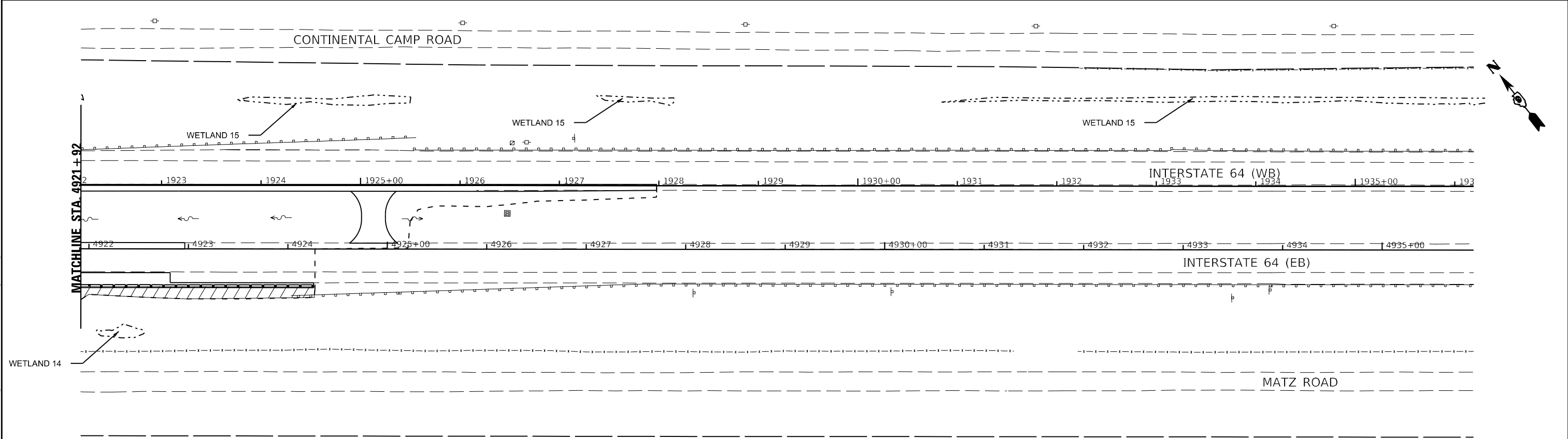
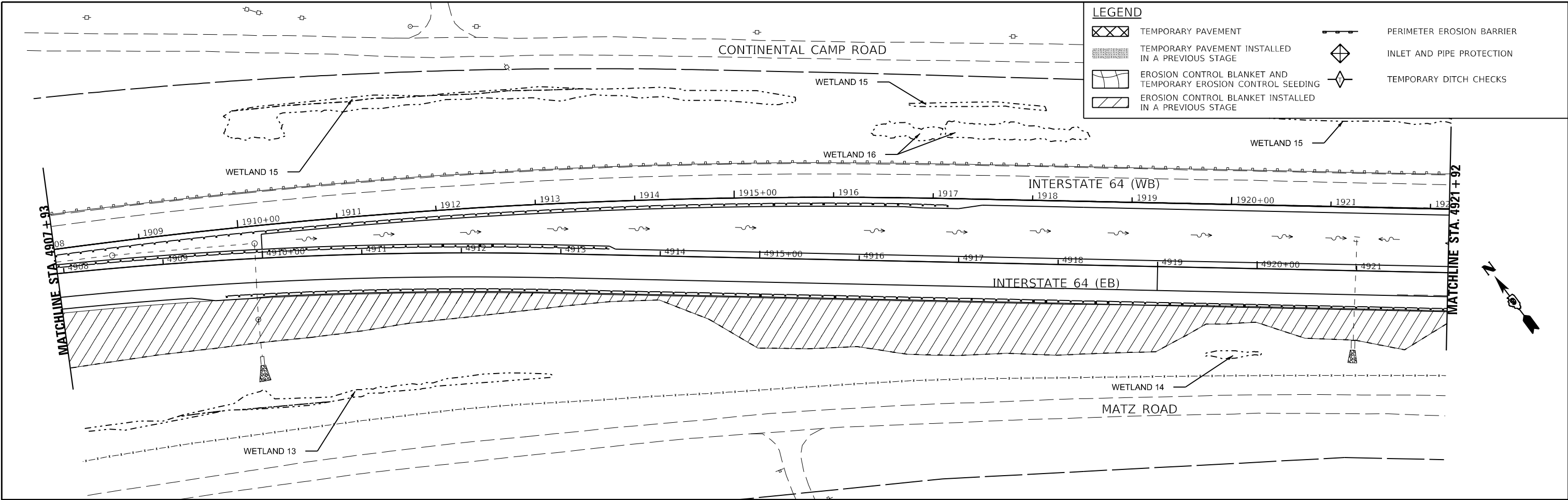

MODEL: \\MODEL\NAME: FILE: \\MODEL\117660\CAD\Drawings\Erosion_Control\Stage_4\I-64\EC-23.dwg - Erosion_Control_Stage_4-03.dwg

KNIGHT
Engineers & Architects

USER NAME = USRA706046	DESIGNED - JS	REVISED - 11/15/2023
PLOT SCALE = 1:100	DRAWN - RTA	REVISED -
PLOT DATE = 11/10/2023	CHECKED - JCM	REVISED -
	DATE - 08/11/2023	REVISED -

**STATE OF ILLINOIS
DEPARTMENT OF TRANSPORTATION**

EROSION CONTROL - STAGE 4		
I-64		
SCALE:	SHEET EC-23 OF 23 SHEETS	STA. TO STA.

F.A.I. RTE.	SECTION	COUNTY	TOTAL SHEETS	SHEET NO.
64	(97-2) B-5	WHITE	578	155
CONTRACT NO. 78057				
ILLINOIS FED. AID PROJECT FAI 64/WABASH RIVER				

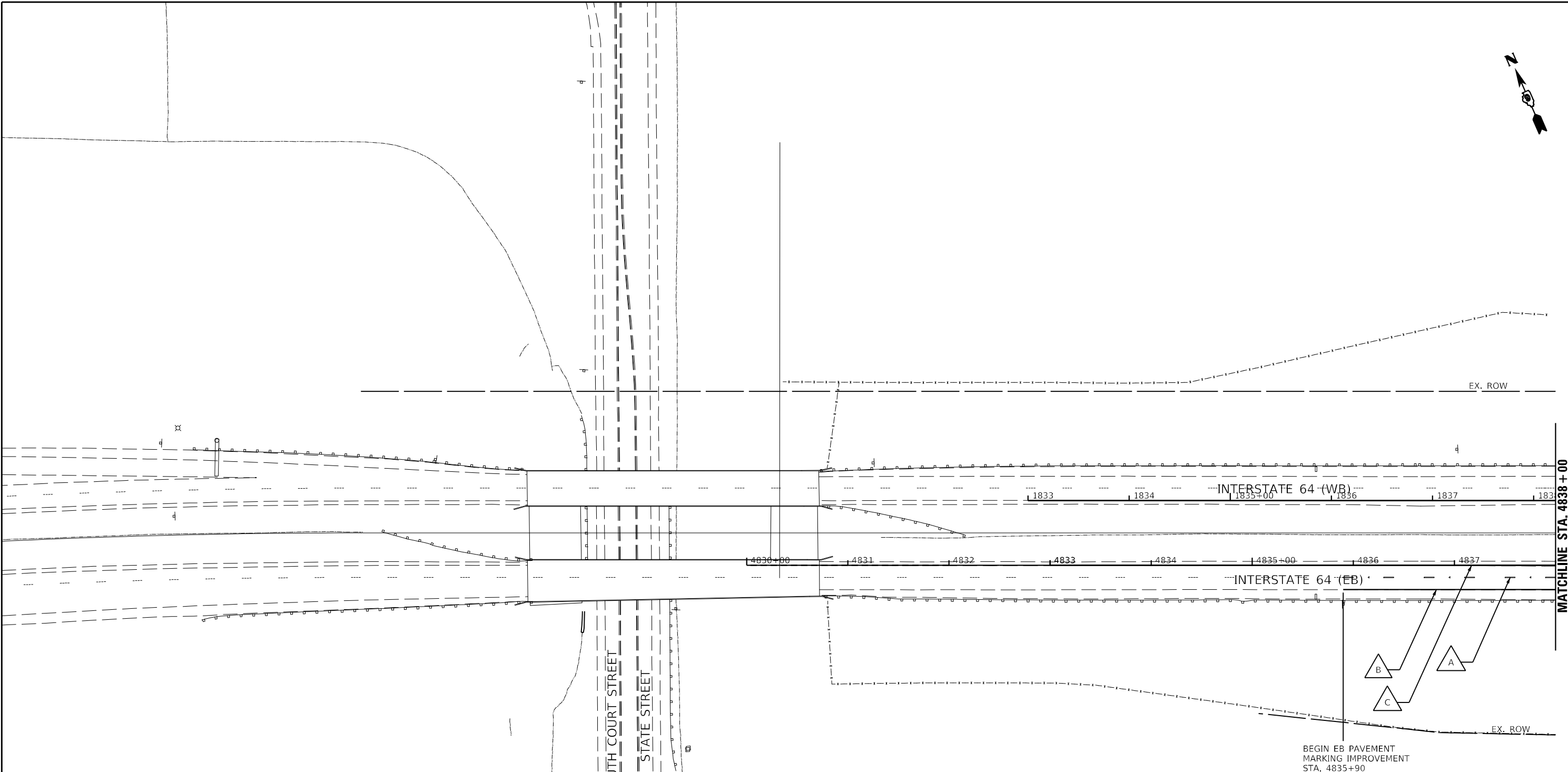

SIGN NUMBERING KEY

DIRECTION OF TRAFFIC/RAMP EB - EASTBOUND WB - WESTBOUND NB - NORTHBOUND SB - SOUTHBOUND		ACTION (R) - REMOVE (SEE REMOVAL PLANS) (P) - PROPOSED (REL) - RELOCATE	
ROADWAY OR INTERCHANGE I64 - INTERSTATE 64 RP - RAMP		SIGN PANEL NUMBER EB - I64 - TR - 01 (X)	
MOUNTING TYPE TR - TRUSS CL - CANTILEVER WP - WOOD POST TS - TELESCOPING STEEL BS - BREAKAWAY STEEL LP - LIGHT POLE MP - MILE POST MARKER			

LEGEND

<p>A THERMOPLASTIC PAVEMENT MARKING - LINE 6", WHITE SKIP-DASH (10' LINE - 30' SPACE), RECESSED; GROOVING FOR RECESSED PAVEMENT MARKING 7"; RAISED REFLECTIVE PAVEMENT MARKERS, ONE-WAY CRYSTAL (SPACED AT 80' C-C)</p> <p>B THERMOPLASTIC PAVEMENT MARKING - LINE 6", SOLID WHITE, RECESSED; GROOVING FOR RECESSED PAVEMENT MARKING 7"</p> <p>C THERMOPLASTIC PAVEMENT MARKING - LINE 6", SOLID YELLOW, RECESSED; GROOVING FOR RECESSED PAVEMENT MARKING 7"</p> <p>D THERMOPLASTIC PAVEMENT MARKING - LINE 8", SOLID WHITE, RECESSED; GROOVING FOR RECESSED PAVEMENT MARKING 9"</p>	<p>E THERMOPLASTIC PAVEMENT MARKING - LINE 6", WHITE DOTTED (2' LINE - 6' SPACE), RECESSED; GROOVING FOR RECESSED PAVEMENT MARKING 7"</p> <p>F POLYUREA PAVEMENT MARKING TYPE 1 - LINE 6", WHITE SKIP-DASH (10' LINE - 30' SPACE), RECESSED; GROOVING FOR RECESSED PAVEMENT MARKING 7"</p> <p>G POLYUREA PAVEMENT MARKING TYPE 1 - LINE 6", SOLID WHITE, RECESSED; GROOVING FOR RECESSED PAVEMENT MARKING 7"</p> <p>H POLYUREA PAVEMENT MARKING TYPE 1 - LINE 6", SOLID YELLOW, RECESSED; GROOVING FOR RECESSED PAVEMENT MARKING 7"</p>
--	---

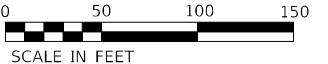

MODEL: I:\MODEL\NAME: FILE: NAME: I:\78057\CAD\IS\sheet\PM\KS\signing\08112023\I-64\pm1.dgn



USER NAME = USIM706109	DESIGNED - JS	REVISED -
PLOT SCALE = 1:100	DRAWN - RTA	REVISED -
PLOT DATE = 8/10/2023	CHECKED - JCM	REVISED -
	DATE - 08/11/2023	REVISED -

STATE OF ILLINOIS
DEPARTMENT OF TRANSPORTATION

PAVEMENT MARKING AND SIGNING PLAN
I-64
 SCALE: SHEET PM-1 OF 24 SHEETS STA. TO STA.

F.A.I. RTE.	SECTION	COUNTY	TOTAL SHEETS	SHEET NO.
64	(97-2) B-5	WHITE	578	156
CONTRACT NO. 78057				
ILLINOIS FED. AID PROJECT FAI 64/WABASH RIVER				

SIGN NUMBERING KEY

DIRECTION OF TRAFFIC/RAMP		ACTION	
EB - EASTBOUND	EB - 164 - TR - 01 (X)	(R) - REMOVE (SEE REMOVAL PLANS)	SIGN PANEL NUMBER
WB - WESTBOUND		(P) - PROPOSED	
NB - NORTHBOUND		(REL) - RELOCATE	
SB - SOUTHBOUND		(EX) - EXISTING TO REMAIN	
ROADWAY OR INTERCHANGE		MOUNTING TYPE	
164 - INTERSTATE 64		TR - TRUSS	
RP - RAMP		CL - CANTILEVER	
		WP - WOOD POST	
		TS - TELESCOPING STEEL	
		BS - BREAKAWAY STEEL	
		LP - LIGHT POLE	
		MP - MILE MARKER POST	

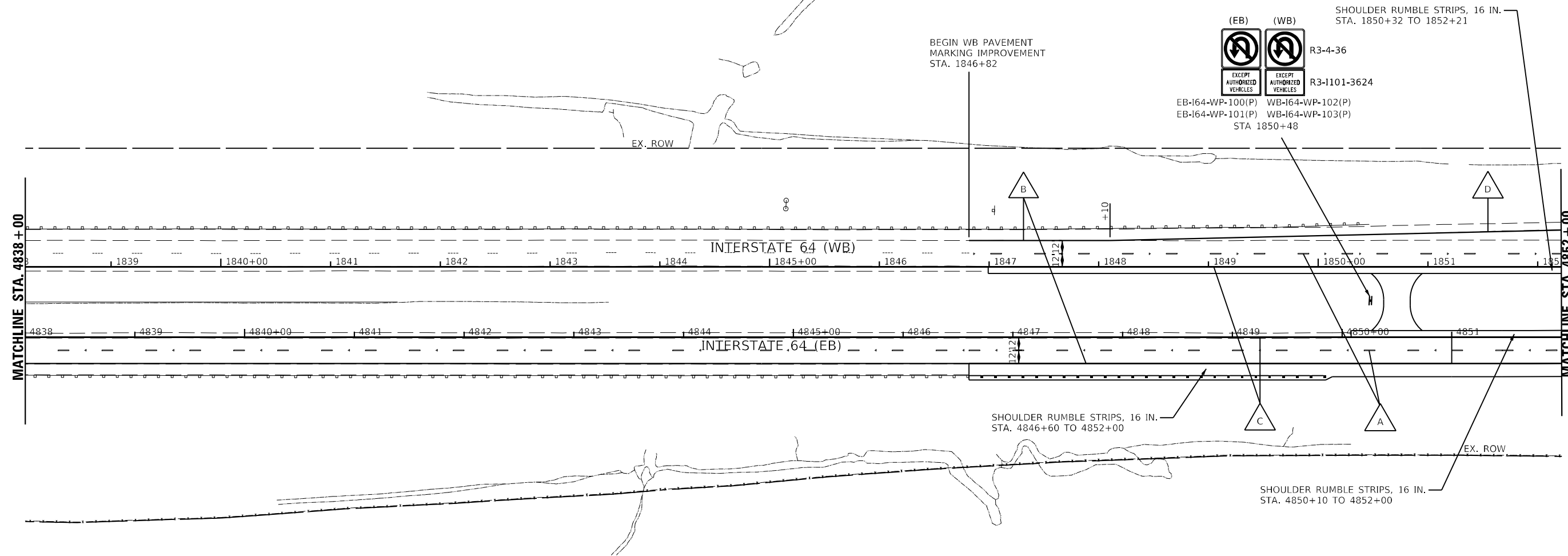

LEGEND

- | | |
|--|---|
| <p>A THERMOPLASTIC PAVEMENT MARKING - LINE 6", WHITE SKIP-DASH (10' LINE - 30' SPACE), RECESSED; GROOVING FOR RECESSED PAVEMENT MARKING 7"; RAISED REFLECTIVE PAVEMENT MARKERS, ONE-WAY CRYSTAL (SPACED AT 80' C-C)</p> <p>B THERMOPLASTIC PAVEMENT MARKING - LINE 6", SOLID WHITE, RECESSED; GROOVING FOR RECESSED PAVEMENT MARKING 7"</p> <p>C THERMOPLASTIC PAVEMENT MARKING - LINE 6", SOLID YELLOW, RECESSED; GROOVING FOR RECESSED PAVEMENT MARKING 7"</p> <p>D THERMOPLASTIC PAVEMENT MARKING - LINE 8", SOLID WHITE, RECESSED; GROOVING FOR RECESSED PAVEMENT MARKING 9"</p> | <p>E THERMOPLASTIC PAVEMENT MARKING - LINE 6", WHITE DOTTED (2' LINE - 6' SPACE), RECESSED; GROOVING FOR RECESSED PAVEMENT MARKING 7"</p> <p>F POLYUREA PAVEMENT MARKING TYPE I - LINE 6", WHITE SKIP-DASH (10' LINE - 30' SPACE), RECESSED; GROOVING FOR RECESSED PAVEMENT MARKING 7"</p> <p>G POLYUREA PAVEMENT MARKING TYPE I - LINE 6", SOLID WHITE, RECESSED; GROOVING FOR RECESSED PAVEMENT MARKING 7"</p> <p>H POLYUREA PAVEMENT MARKING TYPE I - LINE 6", SOLID YELLOW, RECESSED; GROOVING FOR RECESSED PAVEMENT MARKING 7"</p> |
|--|---|

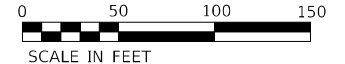

MODEL: I:\MODEL\NAMES FILE NAME: I:\1660\CAD\IS\sheet\PM\KSP\m19\078507-2-shpm19-2.dgn

KNIGHT Engineers & Architects	USER NAME = USJM706109	DESIGNED - JS	REVISED -	STATE OF ILLINOIS DEPARTMENT OF TRANSPORTATION	PAVEMENT MARKING AND SIGNING PLAN		F.A.I. RTE.	SECTION	COUNTY	TOTAL SHEETS	SHEET NO.	
	PLOT SCALE = 1:100	CHECKED - JCM	REVISED -		I-64	64	(97-2) B-5	WHITE	578	157		
PLOT DATE = 8/10/2023	DATE = 08/11/2023	REVISED -		SCALE:	SHEET PM-2	OF 24 SHEETS	STA.	TO STA.	CONTRACT NO. 78057			
								ILLINOIS FED. AID PROJECT FAI 64/WABASH RIVER				

SIGN NUMBERING KEY

DIRECTION OF TRAFFIC/RAMP		ACTION	
EB - EASTBOUND	EB - I64 - TR - 01 (X)	(R) - REMOVE (SEE REMOVAL PLANS)	SIGN PANEL NUMBER
WB - WESTBOUND		(P) - PROPOSED	
NB - NORTHBOUND		(REL) - RELOCATE	
SB - SOUTHBOUND		(EX) - EXISTING TO REMAIN	
ROADWAY OR INTERCHANGE		MOUNTING TYPE	
I64 - INTERSTATE 64		TR - TRUSS	
RP - RAMP		CL - CANTILEVER	
		WP - WOOD POST	
		TS - TELESCOPING STEEL	
		BS - BREAKAWAY STEEL	
		LP - LIGHT POLE	
		MP - MILE MARKER POST	

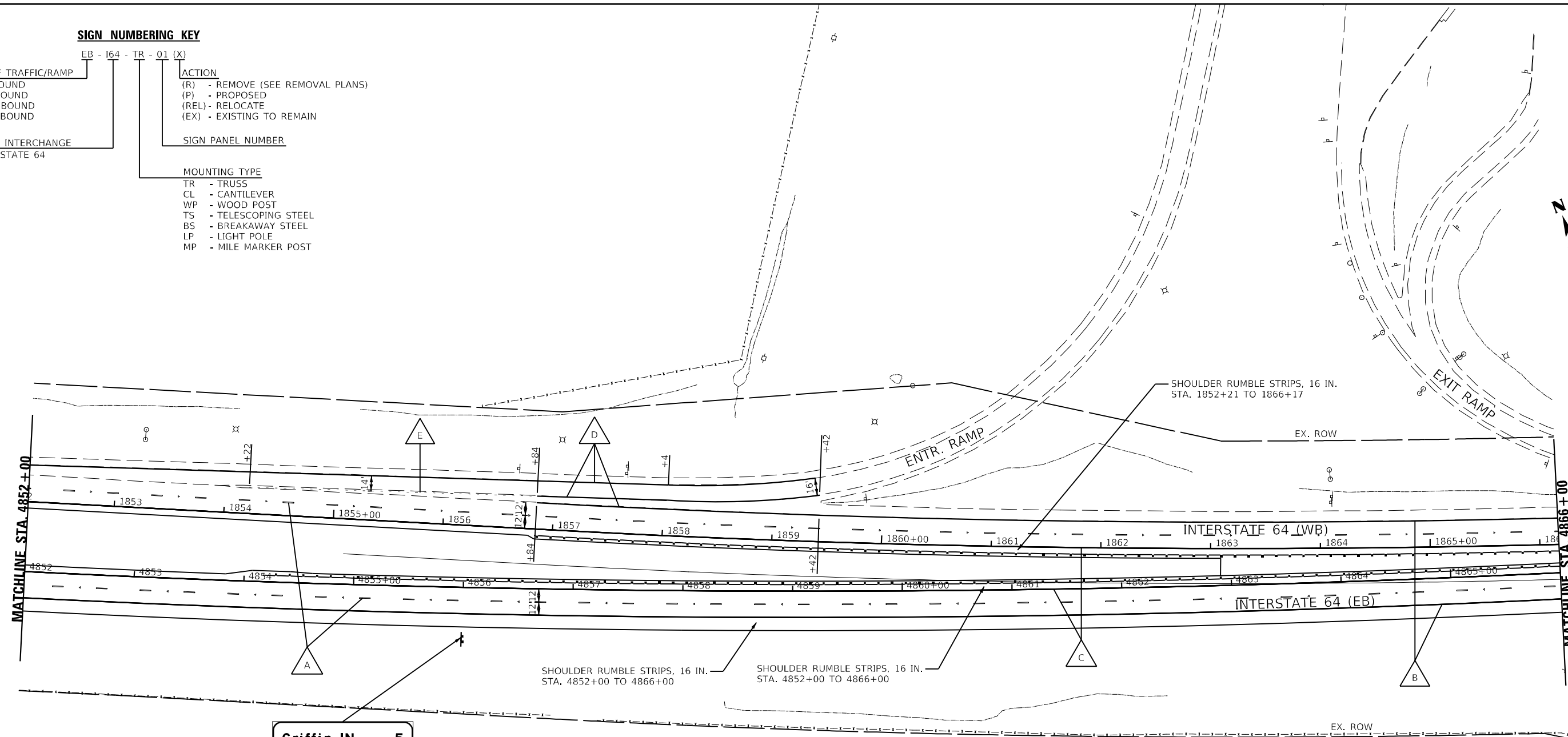

Griffin IN	5
Evansville	39
Louisville	130

EB-I64-BS-104(P)
 STA 4856+00
 SEE BREAKAWAY
 STEEL SIGN DETAILS

LEGEND

- | | | | |
|--|--|--|---|
| | THERMOPLASTIC PAVEMENT MARKING - LINE 6", WHITE SKIP-DASH (10' LINE - 30' SPACE), RECESSED; GROOVING FOR RECESSED PAVEMENT MARKING 7"; RAISED REFLECTIVE PAVEMENT MARKERS, ONE-WAY CRYSTAL (SPACED AT 80' C-C) | | THERMOPLASTIC PAVEMENT MARKING - LINE 6", WHITE DOTTED (2' LINE - 6' SPACE), RECESSED; GROOVING FOR RECESSED PAVEMENT MARKING 7" |
| | THERMOPLASTIC PAVEMENT MARKING - LINE 6", SOLID WHITE, RECESSED; GROOVING FOR RECESSED PAVEMENT MARKING 7" | | POLYUREA PAVEMENT MARKING TYPE 1 - LINE 6", WHITE SKIP-DASH (10' LINE - 30' SPACE), RECESSED; GROOVING FOR RECESSED PAVEMENT MARKING 7" |
| | THERMOPLASTIC PAVEMENT MARKING - LINE 6", SOLID YELLOW, RECESSED; GROOVING FOR RECESSED PAVEMENT MARKING 7" | | POLYUREA PAVEMENT MARKING TYPE 1 - LINE 6", SOLID WHITE, RECESSED; GROOVING FOR RECESSED PAVEMENT MARKING 7" |
| | THERMOPLASTIC PAVEMENT MARKING - LINE 8", SOLID WHITE, RECESSED; GROOVING FOR RECESSED PAVEMENT MARKING 9" | | POLYUREA PAVEMENT MARKING TYPE 1 - LINE 6", SOLID YELLOW, RECESSED; GROOVING FOR RECESSED PAVEMENT MARKING 7" |

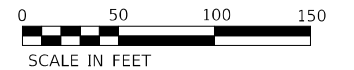

MODEL: 44001ELNAMES
 FILE NAME: D:\660\ICAD\Projects\PM&S\I64\978507-2\shgpm3-3.dgn



USER NAME = USJM706109	DESIGNED - JS	REVISED -
PLOT SCALE = 1:100	DRAWN - RTA	REVISED -
PLOT DATE = 8/10/2023	CHECKED - JCM	REVISED -
	DATE - 08/11/2023	REVISED -

**STATE OF ILLINOIS
 DEPARTMENT OF TRANSPORTATION**

**PAVEMENT MARKING AND SIGNING PLAN
 I-64**

SCALE: SHEET PM-3 OF 24 SHEETS STA. TO STA.

F.A.I. RTE.	SECTION	COUNTY	TOTAL SHEETS	SHEET NO.
64	(97-2) B-5	WHITE	578	158
CONTRACT NO. 78057				
ILLINOIS FED. AID PROJECT FAI 64/WABASH RIVER				

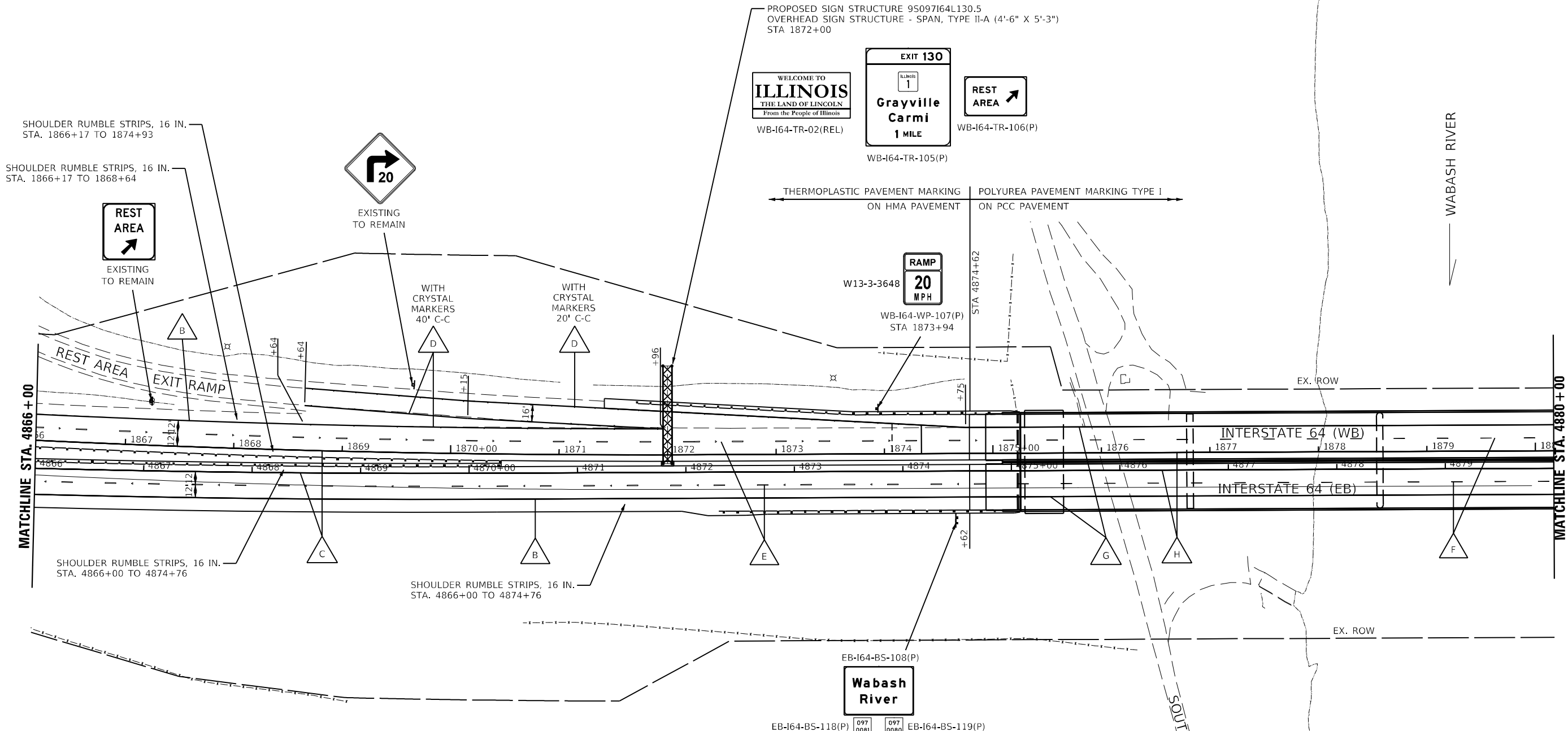

LEGEND

- | | |
|---|--|
| <ul style="list-style-type: none"> A THERMOPLASTIC PAVEMENT MARKING - LINE 6", WHITE SKIP-DASH (10' LINE - 30' SPACE), RECESSED; GROOVING FOR RECESSED PAVEMENT MARKING 7"; RAISED REFLECTIVE PAVEMENT MARKERS, ONE-WAY CRYSTAL (SPACED AT 80' C-C) B THERMOPLASTIC PAVEMENT MARKING - LINE 6", SOLID WHITE, RECESSED; GROOVING FOR RECESSED PAVEMENT MARKING 7" C THERMOPLASTIC PAVEMENT MARKING - LINE 6", SOLID YELLOW, RECESSED; GROOVING FOR RECESSED PAVEMENT MARKING 7" D THERMOPLASTIC PAVEMENT MARKING - LINE 8", SOLID WHITE, RECESSED; GROOVING FOR RECESSED PAVEMENT MARKING 9" | <ul style="list-style-type: none"> E THERMOPLASTIC PAVEMENT MARKING - LINE 6", WHITE DOTTED (2' LINE - 6' SPACE), RECESSED; GROOVING FOR RECESSED PAVEMENT MARKING 7" F POLYUREA PAVEMENT MARKING TYPE I - LINE 6", WHITE SKIP-DASH (10' LINE - 30' SPACE), RECESSED; GROOVING FOR RECESSED PAVEMENT MARKING 7" G POLYUREA PAVEMENT MARKING TYPE I - LINE 6", SOLID WHITE, RECESSED; GROOVING FOR RECESSED PAVEMENT MARKING 7" H POLYUREA PAVEMENT MARKING TYPE I - LINE 6", SOLID YELLOW, RECESSED; GROOVING FOR RECESSED PAVEMENT MARKING 7" |
|---|--|

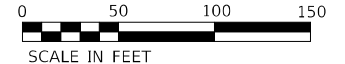

MODEL: 440081.NAMES
 FILE NAME: C:\PROJECTS\I64\I64WB\I64WB.dgn

KNIGHT Engineers & Architects	USER NAME = USJM706109	DESIGNED - JS	REVISED -
	PLOT SCALE = 1:100	DRAWN - RTA	REVISED -
	PLOT DATE = 8/10/2023	CHECKED - JCM	REVISED -
		DATE - 08/11/2023	REVISED -

STATE OF ILLINOIS
DEPARTMENT OF TRANSPORTATION

PAVEMENT MARKING AND SIGNING PLAN			
I-64			
SCALE:	SHEET PM-4	OF 24 SHEETS	STA. TO STA.

F.A.I. RTE.	SECTION	COUNTY	TOTAL SHEETS	SHEET NO.
64	(97-2) B-5	WHITE	578	159
CONTRACT NO. 78057				
ILLINOIS FED. AID PROJECT FAI 64/WABASH RIVER				

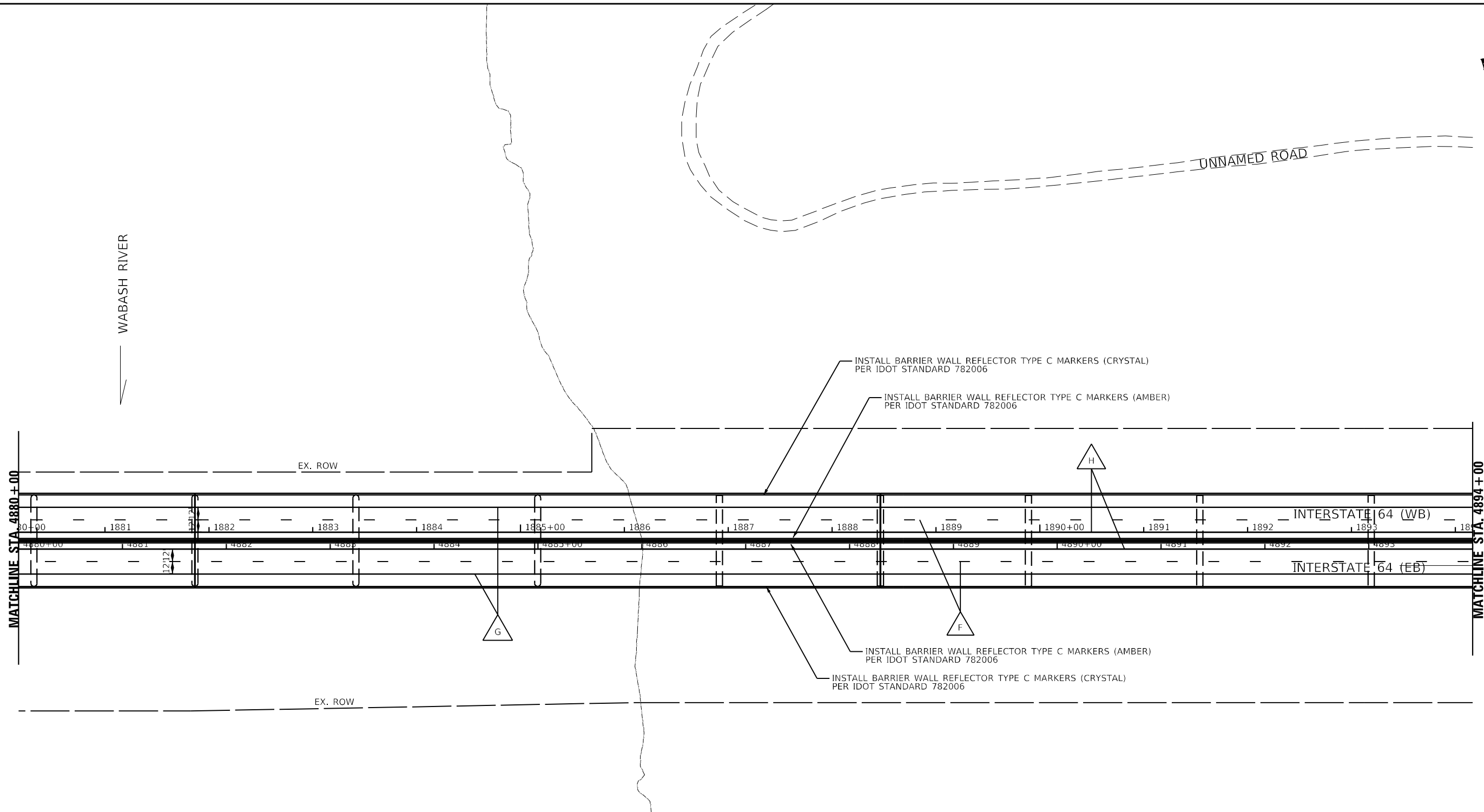

LEGEND

- | | |
|--|---|
| <p>A THERMOPLASTIC PAVEMENT MARKING - LINE 6", WHITE SKIP-DASH (10' LINE - 30' SPACE), RECESSED; GROOVING FOR RECESSED PAVEMENT MARKING 7"; RAISED REFLECTIVE PAVEMENT MARKERS, ONE-WAY CRYSTAL (SPACED AT 80' C-C)</p> <p>B THERMOPLASTIC PAVEMENT MARKING - LINE 6", SOLID WHITE, RECESSED; GROOVING FOR RECESSED PAVEMENT MARKING 7"</p> <p>C THERMOPLASTIC PAVEMENT MARKING - LINE 6", SOLID YELLOW, RECESSED; GROOVING FOR RECESSED PAVEMENT MARKING 7"</p> <p>D THERMOPLASTIC PAVEMENT MARKING - LINE 8", SOLID WHITE, RECESSED; GROOVING FOR RECESSED PAVEMENT MARKING 9"</p> | <p>E THERMOPLASTIC PAVEMENT MARKING - LINE 6", WHITE DOTTED (2' LINE - 6' SPACE), RECESSED; GROOVING FOR RECESSED PAVEMENT MARKING 7"</p> <p>F POLYUREA PAVEMENT MARKING TYPE I - LINE 6", WHITE SKIP-DASH (10' LINE - 30' SPACE), RECESSED; GROOVING FOR RECESSED PAVEMENT MARKING 7"</p> <p>G POLYUREA PAVEMENT MARKING TYPE I - LINE 6", SOLID WHITE, RECESSED; GROOVING FOR RECESSED PAVEMENT MARKING 7"</p> <p>H POLYUREA PAVEMENT MARKING TYPE I - LINE 6", SOLID YELLOW, RECESSED; GROOVING FOR RECESSED PAVEMENT MARKING 7"</p> |
|--|---|

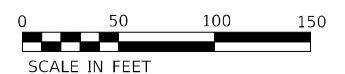

MODEL: 4400161.DWG
 FILE NAME: 4400161.DWG
 USER: JCM
 DATE: 8/10/2023



USER NAME = USJM706109	DESIGNED - JS	REVISED -
PLOT SCALE = 1:100	DRAWN - RTA	REVISED -
PLOT DATE = 8/10/2023	CHECKED - JCM	REVISED -
	DATE - 08/11/2023	REVISED -

STATE OF ILLINOIS
DEPARTMENT OF TRANSPORTATION

PAVEMENT MARKING AND SIGNING PLAN			
I-64			
SCALE:	SHEET PM-5	OF 24 SHEETS	STA. TO STA.

F.A.I. RTE.	SECTION	COUNTY	TOTAL SHEETS	SHEET NO.
64	(97-2) B-5	WHITE	578	160
CONTRACT NO. 78057				
ILLINOIS FED. AID PROJECT FAI 64/WABASH RIVER				

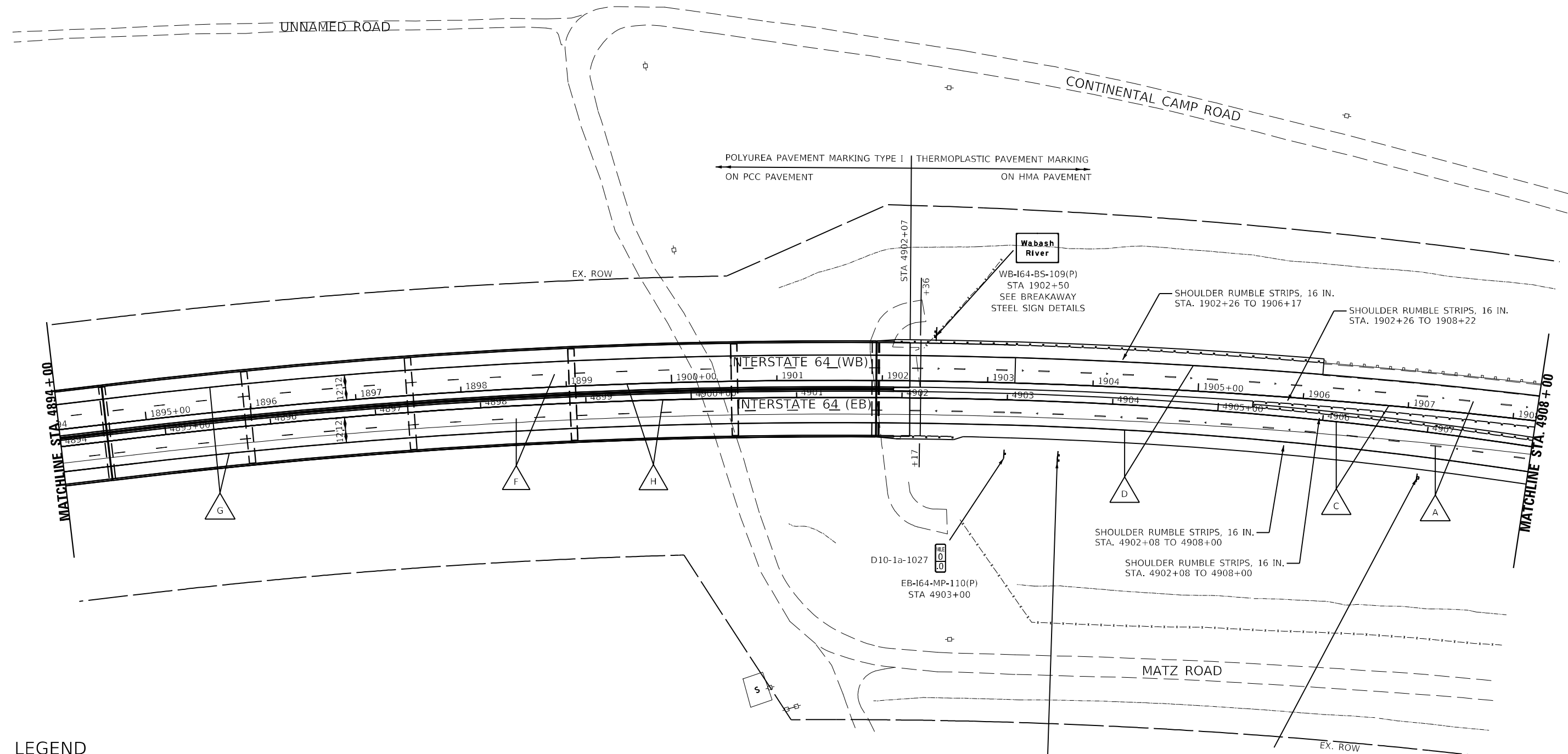

LEGEND

- | | |
|--|---|
| <p>A THERMOPLASTIC PAVEMENT MARKING - LINE 6", WHITE SKIP-DASH (10' LINE - 30' SPACE), RECESSED; GROOVING FOR RECESSED PAVEMENT MARKING 7"; RAISED REFLECTIVE PAVEMENT MARKERS, ONE-WAY CRYSTAL (SPACED AT 80' C-C)</p> <p>B THERMOPLASTIC PAVEMENT MARKING - LINE 6", SOLID WHITE, RECESSED; GROOVING FOR RECESSED PAVEMENT MARKING 7"</p> <p>C THERMOPLASTIC PAVEMENT MARKING - LINE 6", SOLID YELLOW, RECESSED; GROOVING FOR RECESSED PAVEMENT MARKING 7"</p> <p>D THERMOPLASTIC PAVEMENT MARKING - LINE 8", SOLID WHITE, RECESSED; GROOVING FOR RECESSED PAVEMENT MARKING 9"</p> | <p>E THERMOPLASTIC PAVEMENT MARKING - LINE 6", WHITE DOTTED (2' LINE - 6' SPACE), RECESSED; GROOVING FOR RECESSED PAVEMENT MARKING 7"</p> <p>F POLYUREA PAVEMENT MARKING TYPE I - LINE 6", WHITE SKIP-DASH (10' LINE - 30' SPACE), RECESSED; GROOVING FOR RECESSED PAVEMENT MARKING 7"</p> <p>G POLYUREA PAVEMENT MARKING TYPE I - LINE 6", SOLID WHITE, RECESSED; GROOVING FOR RECESSED PAVEMENT MARKING 7"</p> <p>H POLYUREA PAVEMENT MARKING TYPE I - LINE 6", SOLID YELLOW, RECESSED; GROOVING FOR RECESSED PAVEMENT MARKING 7"</p> |
|--|---|

Welcome to
Indiana
Crossroads of America
Lincoln's Boyhood Home

Benjamin Harrison
America's Hoosier President

STA 4903+50
RELOCATE SIGN PANELS ON
NEW BREAKAWAY STEEL SIGN SUPPORTS



EB-I64-TS-12(REL)
STA 4907+00

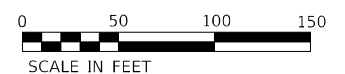

MODEL: 440021.DWG
FILE NAME: I-64WBASH.DWG
DATE: 08/11/2023



USER NAME = USJM706109	DESIGNED - JS	REVISED -
PLOT SCALE = 1:100	DRAWN - RTA	REVISED -
PLOT DATE = 8/10/2023	CHECKED - JCM	REVISED -
	DATE - 08/11/2023	REVISED -

**STATE OF ILLINOIS
DEPARTMENT OF TRANSPORTATION**







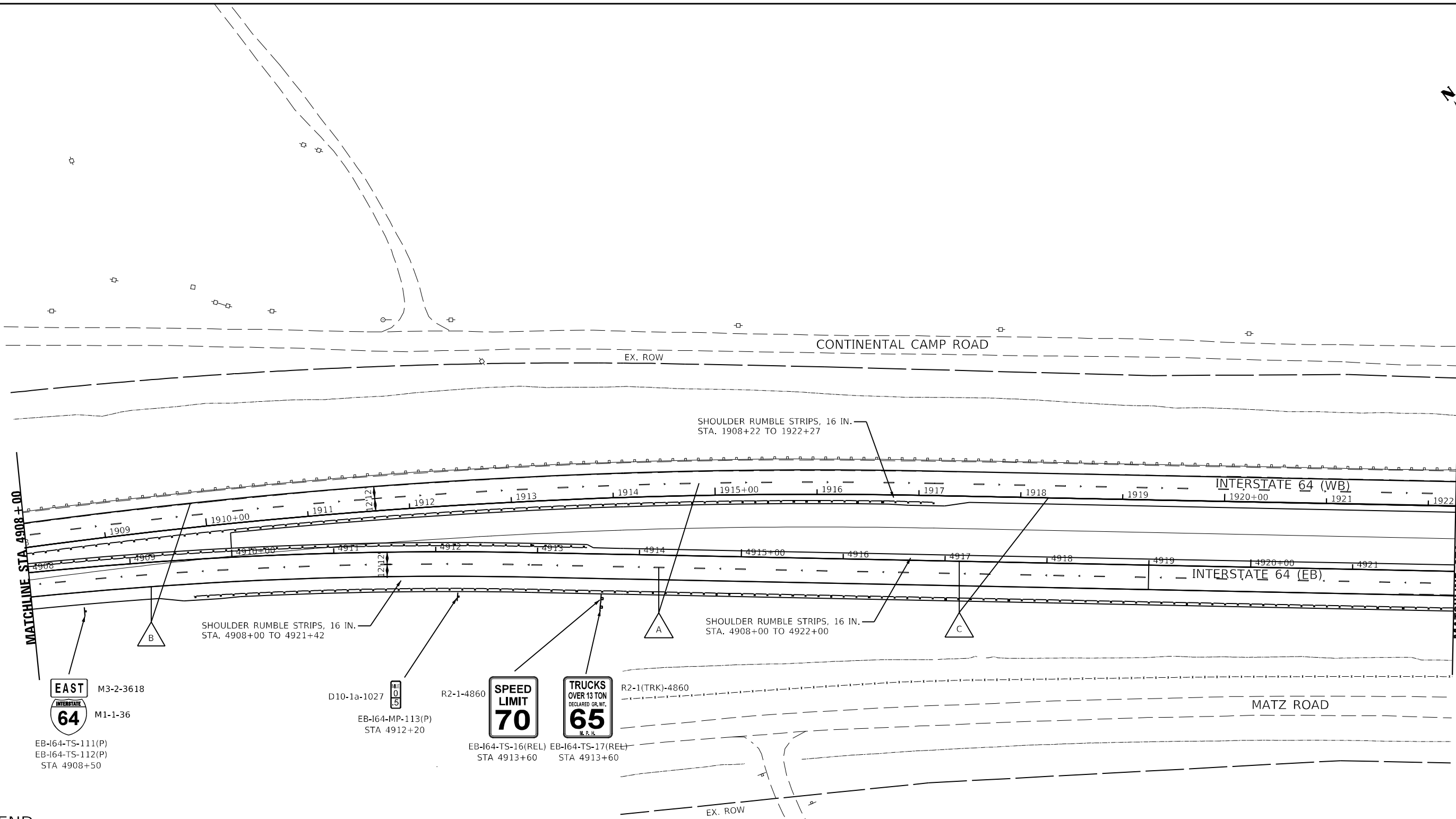

**PAVEMENT MARKING AND SIGNING PLAN
I-64**

SCALE: SHEET PM-6 OF 24 SHEETS STA. TO STA.

F.A.I. RTE.	SECTION	COUNTY	TOTAL SHEETS	SHEET NO.
64	(97-2) B-5	WHITE	578	161
CONTRACT NO. 78057				
ILLINOIS FED. AID PROJECT FAI 64/WABASH RIVER				



LEGEND

-  THERMOPLASTIC PAVEMENT MARKING - LINE 6", WHITE SKIP-DASH (10' LINE - 30' SPACE), RECESSED; GROOVING FOR RECESSED PAVEMENT MARKING 7"; RAISED REFLECTIVE PAVEMENT MARKERS, ONE-WAY CRYSTAL (SPACED AT 80' C-C)
-  THERMOPLASTIC PAVEMENT MARKING - LINE 6", SOLID WHITE, RECESSED; GROOVING FOR RECESSED PAVEMENT MARKING 7"
-  THERMOPLASTIC PAVEMENT MARKING - LINE 6", SOLID YELLOW, RECESSED; GROOVING FOR RECESSED PAVEMENT MARKING 7"
-  THERMOPLASTIC PAVEMENT MARKING - LINE 8", SOLID WHITE, RECESSED; GROOVING FOR RECESSED PAVEMENT MARKING 9"
-  THERMOPLASTIC PAVEMENT MARKING - LINE 6", WHITE DOTTED (2' LINE - 6' SPACE), RECESSED; GROOVING FOR RECESSED PAVEMENT MARKING 7"
-  POLYUREA PAVEMENT MARKING TYPE I - LINE 6", WHITE SKIP-DASH (10' LINE - 30' SPACE), RECESSED; GROOVING FOR RECESSED PAVEMENT MARKING 7"
-  POLYUREA PAVEMENT MARKING TYPE I - LINE 6", SOLID WHITE, RECESSED; GROOVING FOR RECESSED PAVEMENT MARKING 7"
-  POLYUREA PAVEMENT MARKING TYPE I - LINE 6", SOLID YELLOW, RECESSED; GROOVING FOR RECESSED PAVEMENT MARKING 7"

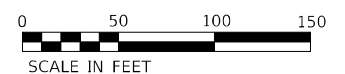

MODEL: I-64.DWG
FILE NAME: I-64.DWG
DATE: 8/10/2023



USER NAME = USJM706109	DESIGNED - JS	REVISED -
PLOT SCALE = 1:100	DRAWN - RTA	REVISED -
PLOT DATE = 8/10/2023	CHECKED - JCM	REVISED -
	DATE - 08/11/2023	REVISED -

**STATE OF ILLINOIS
DEPARTMENT OF TRANSPORTATION**

**PAVEMENT MARKING AND SIGNING PLAN
I-64**

SCALE: SHEET PM-7 OF 24 SHEETS STA. TO STA.

F.A.I. RTE.	SECTION	COUNTY	TOTAL SHEETS	SHEET NO.
64	(97-2) B-5	WHITE	578	162
CONTRACT NO. 78057				
ILLINOIS FED. AID PROJECT FAI 64/WABASH RIVER				

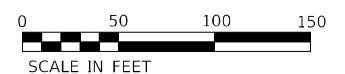
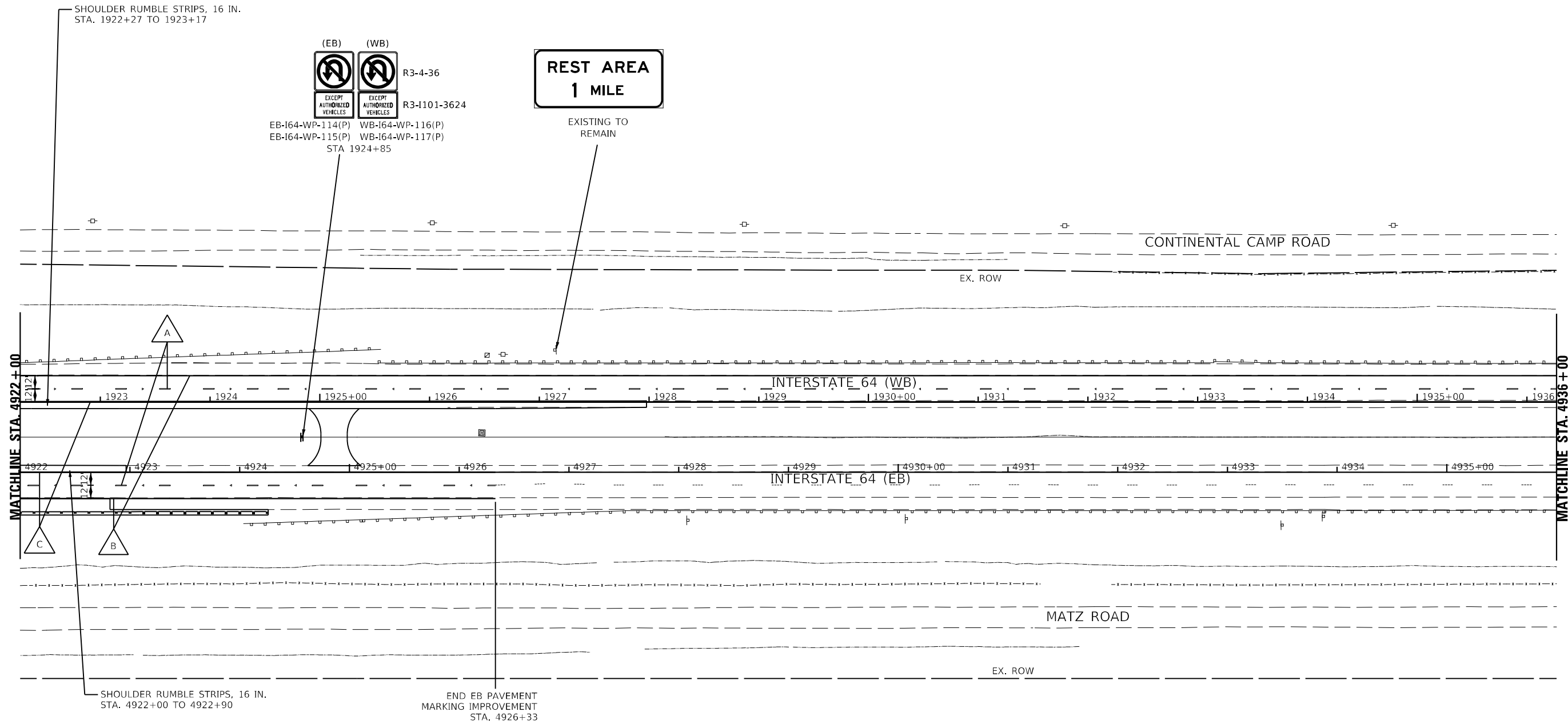
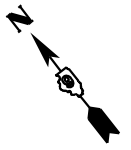

MODEL: I:\MODEL\NAME
 FILE NAME: I:\2023\CAD\Projects\PM\KSP\mha.D978507-2-24-hghm-8.dgn



USER NAME = USIM706109	DESIGNED - JS	REVISED -
PLOT SCALE = 1:100	DRAWN - RTA	REVISED -
PLOT DATE = 8/10/2023	CHECKED - JCM	REVISED -
	DATE - 08/11/2023	REVISED -

STATE OF ILLINOIS
DEPARTMENT OF TRANSPORTATION

PAVEMENT MARKING AND SIGNING PLAN			
I-64			
SCALE:	SHEET PM-8	OF 24 SHEETS	STA. TO STA.

F.A.I. RTE.	SECTION	COUNTY	TOTAL SHEETS	SHEET NO.
64	(97-2) B-5	WHITE	578	163
CONTRACT NO. 78057				
ILLINOIS FED. AID PROJECT FAI 64/WABASH RIVER				

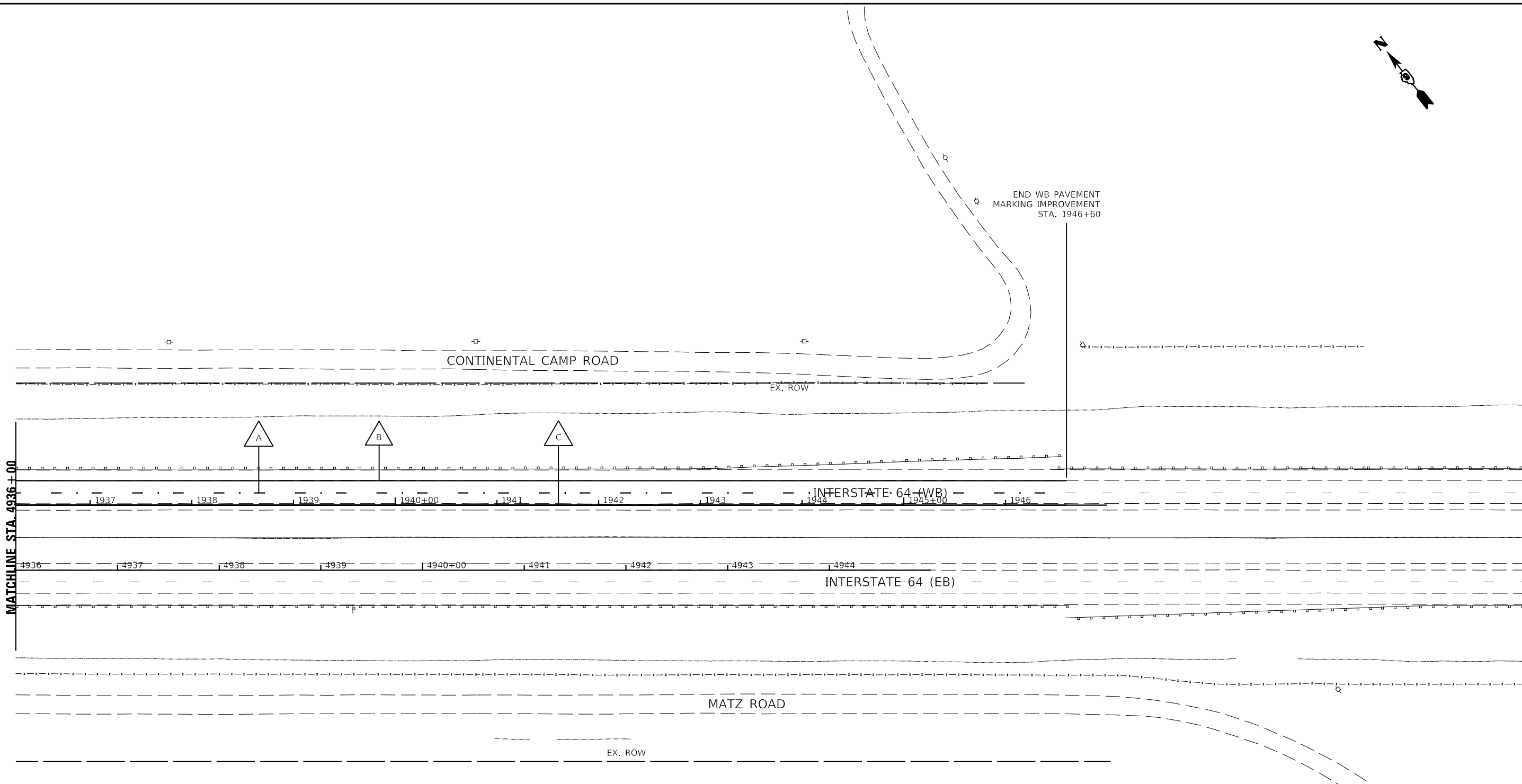
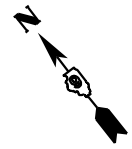

LEGEND

- | | |
|--|---|
| <p>A THERMOPLASTIC PAVEMENT MARKING - LINE 6", WHITE SKIP-DASH (10' LINE - 30' SPACE), RECESSED; GROOVING FOR RECESSED PAVEMENT MARKING 7"; RAISED REFLECTIVE PAVEMENT MARKERS, ONE-WAY CRYSTAL (SPACED AT 80' C-C)</p> <p>B THERMOPLASTIC PAVEMENT MARKING - LINE 6", SOLID WHITE, RECESSED; GROOVING FOR RECESSED PAVEMENT MARKING 7"</p> <p>C THERMOPLASTIC PAVEMENT MARKING - LINE 6", SOLID YELLOW, RECESSED; GROOVING FOR RECESSED PAVEMENT MARKING 7"</p> <p>D THERMOPLASTIC PAVEMENT MARKING - LINE 8", SOLID WHITE, RECESSED; GROOVING FOR RECESSED PAVEMENT MARKING 9"</p> | <p>E THERMOPLASTIC PAVEMENT MARKING - LINE 6", WHITE DOTTED (2' LINE - 6' SPACE), RECESSED; GROOVING FOR RECESSED PAVEMENT MARKING 7"</p> <p>F POLYUREA PAVEMENT MARKING TYPE I - LINE 6", WHITE SKIP-DASH (10' LINE - 30' SPACE), RECESSED; GROOVING FOR RECESSED PAVEMENT MARKING 7"</p> <p>G POLYUREA PAVEMENT MARKING TYPE I - LINE 6", SOLID WHITE, RECESSED; GROOVING FOR RECESSED PAVEMENT MARKING 7"</p> <p>H POLYUREA PAVEMENT MARKING TYPE I - LINE 6", SOLID YELLOW, RECESSED; GROOVING FOR RECESSED PAVEMENT MARKING 7"</p> |
|--|---|



MODEL: I:\MODEL\NAMES
 FILE NAME: I:\2023\CD\Projects\PMK\Signing\081123\I-64\WB\PM-9.dgn



USER NAME = USIM706109	DESIGNED - JS	REVISED -
PLOT SCALE = 1:100	DRAWN - RTA	REVISED -
PLOT DATE = 8/10/2023	CHECKED - JCM	REVISED -
	DATE - 08/11/2023	REVISED -

STATE OF ILLINOIS
DEPARTMENT OF TRANSPORTATION

PAVEMENT MARKING AND SIGNING PLAN
I-64

SCALE: SHEET PM-9 OF 24 SHEETS STA. TO STA.

F.A.I. RTE.	SECTION	COUNTY	TOTAL SHEETS	SHEET NO.
64	(97-2) B-5	WHITE	578	164
CONTRACT NO. 78057				
ILLINOIS FED. AID PROJECT FAI 64/WABASH RIVER				

SIGN DETAIL
1:80

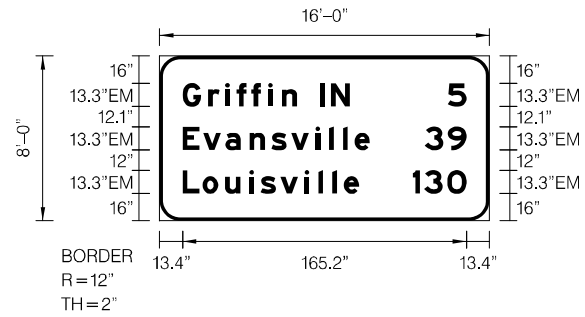

SIGN NUMBER	EB-164-BS-104(P)
WIDTH x HGHT.	16'-0" x 8'-0"
BORDER WIDTH	2"
CORNER RADIUS	12"
MOUNTING	Overhead
BACKGROUND	TYPE: AP SHEETING COLOR: Green
LEGEND/BORDER	TYPE: AP SHEETING COLOR: White/White

SYMBOL	ROT	X	Y	WID	HT

Panel Style: guide_exp_interchangeSequence.ssi
Dimensions are in inches, tenths
Letter locations are paneledge to lower left corner

LETTER POSITIONS (X)											LENGTH	SERIES/SIZE	
G	r	i	f	f	i	n		I	N			EM 2000	
13.4	28.3	38.2	44.9	53.3	63.1	71.2	80	93.4	99.8			97.3	13.410
5													EM 2000
167.8												10.8	13.3
E	v	a	n	s	v	i		I	I	e			EM 2000
13.4	25.4	38.3	52.5	65.1	76.6	90.7	98.7	106.7	113.5			108.9	13.310
3	9												EM 2000
154.3	167.8											24.3	13.3
L	o	u	i	s	v	i		I	I	e			EM 2000
13.4	25	38.2	52.3	58.9	70.3	84.5	92.5	100.5	107.3			102.7	13.310
1	3	0											EM 2000
147.4	153.9	167.4										31.2	13.3

SIGN DETAIL
1:80

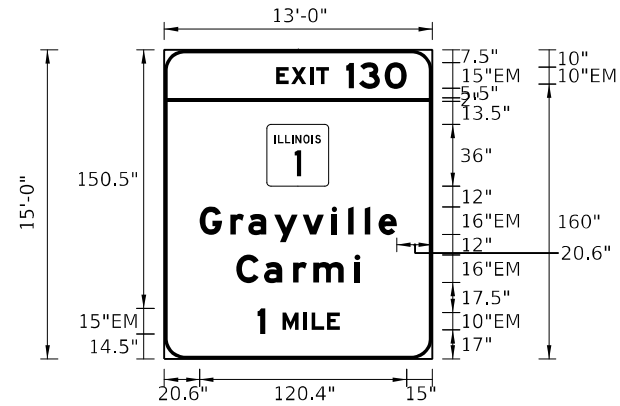

SIGN NUMBER	WB-164-TR-105(P)
WIDTH x HGHT.	13'-0" x 15'-0"
BORDER WIDTH	2"
CORNER RADIUS	12"
MOUNTING	Overhead
BACKGROUND	TYPE: ZZ SHEETING COLOR: Green
LEGEND/BORDER	TYPE: ZZ SHEETING COLOR: White/White

SYMBOL	ROT	X	Y	WID	HT
M1-100a	0	59.7	100.5	36	36

Panel Style: guide_exp_adv_intermediate(IDOT).ssi
Dimensions are in inches, tenths
Letter locations are paneledge to lower left corner

LETTER POSITIONS (X)											LENGTH	SERIES/SIZE		
E	X	I	T	I	3	0							EM 2000	
65.1	73.9	84.7	88.5	105.9	113.3	128.4							75.9	10.15
G	r	a	y	v	i	I	I	e					EM 2000	
20.6	38.4	48.8	64	80.5	97.4	107	116.6	124.8					114.7	16.12
C	a	r	m	i									EM 2000	
42	58	75	86.8	110.8									72	16.12
1	M	I	L	E									EM 2000	
54.4	68.9	81	85.8	94.8									47.8	15.10

MODEL: 44001ELNAME
FILE NAME: C:\2023\CAD\Projects\PMK\Spring\0376507-2\shd\p011.dgn



USER NAME =	USJM706109	DESIGNED -	JS	REVISED -	
DRAWN -	RTA	REVISOR -		REVISOR -	
PLOT SCALE =	1:9.31349	CHECKED -	JCM	REVISOR -	
PLOT DATE =	8/10/2023	DATE -	08/11/2023	REVISOR -	

STATE OF ILLINOIS
DEPARTMENT OF TRANSPORTATION

PROPOSED SIGN PANEL DETAILS
I-64

SCALE: SHEET PM-10 OF 24 SHEETS STA. TO STA.

F.A.I. RTE.	SECTION	COUNTY	TOTAL SHEETS	SHEET NO.
64	(97-2) B-5	WHITE	578	165
CONTRACT NO. 78057				
ILLINOIS FED. AID PROJECT FAI 64/WABASH RIVER				

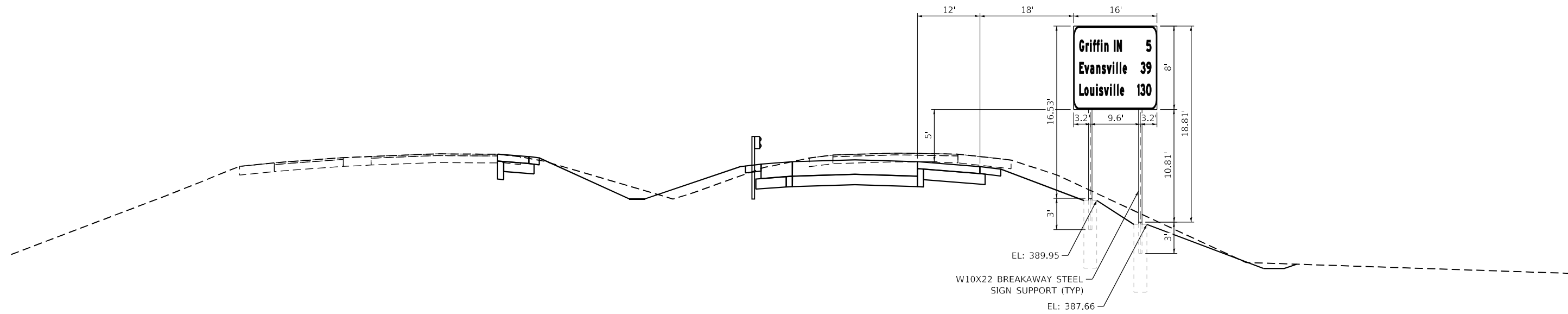

**GROUND MOUNTED BREAKAWAY
STEEL SIGN SUPPORT
STA 4856+00 (LOOKING EAST)**

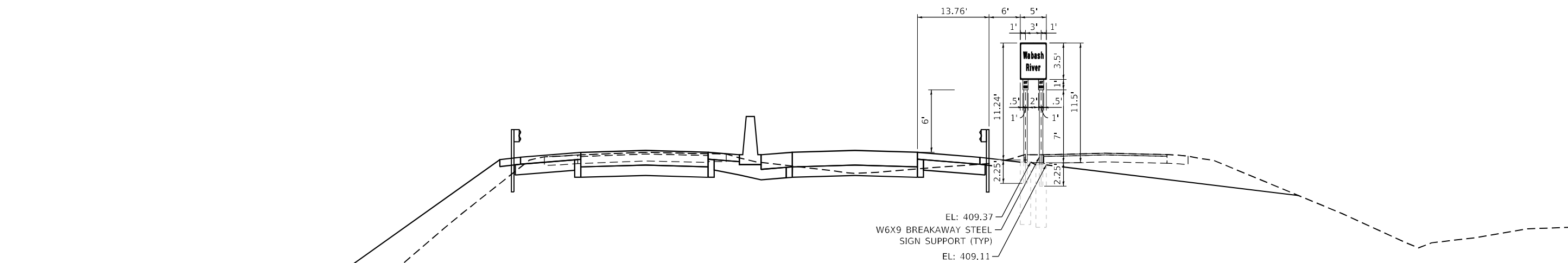

**GROUND MOUNTED BREAKAWAY
STEEL SIGN SUPPORT
STA 4874+50 (LOOKING EAST)**

MODEL: D:\dgn\...
FILE NAME: E:\09 E:\CADD_Sheets\0978057-ctb-adj\ref\station_01.dgn



USER NAME = r0ber	DESIGNED - RC	REVISED -
PLOT SCALE = 20,0000 * / in.	DRAWN - RC	REVISED -
PLOT DATE = 6-7-2022	CHECKED - ST	REVISED -
	DATE - 6/30/2023	REVISED -

**STATE OF ILLINOIS
DEPARTMENT OF TRANSPORTATION**

**SIGN ELEVATION DETAILS
I-64 OVER WABASH RIVER**

SCALE: N.T.S. SHEET 1 OF 3 SHEETS STA. TO STA.

F.A.I. RTE.	SECTION	COUNTY	TOTAL SHEETS	SHEET NO.
64	(97-2) B-5	WHITE	578	167
CONTRACT NO. 78057				
ILLINOIS FED. AID PROJECT FAI 64/WABASH RIVER				

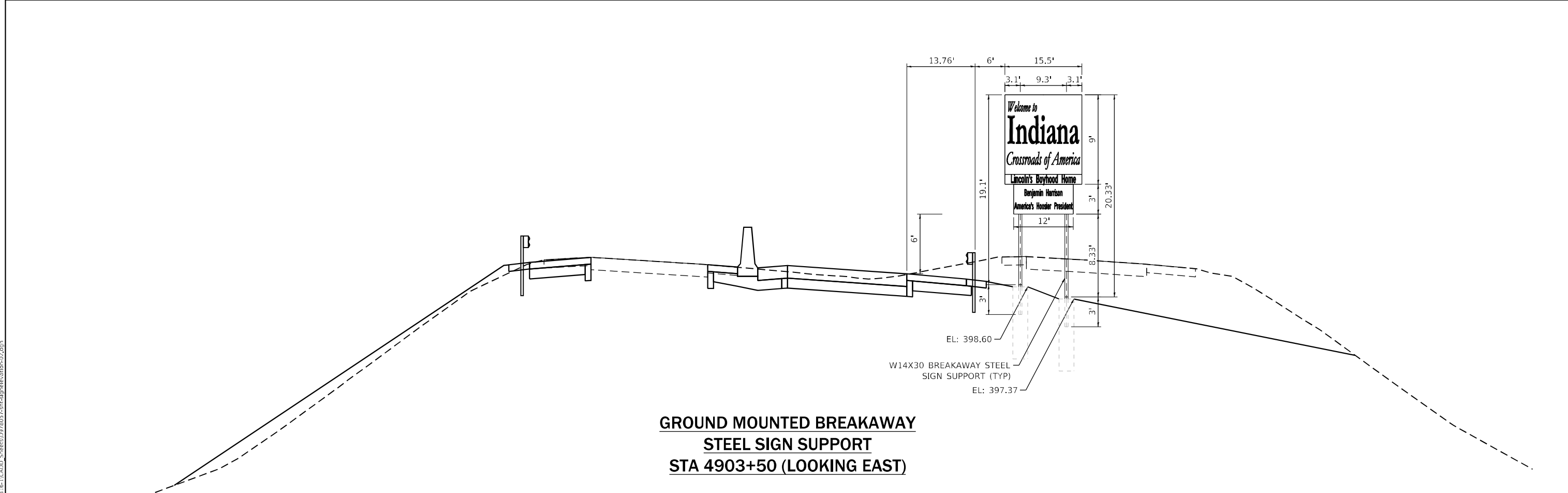
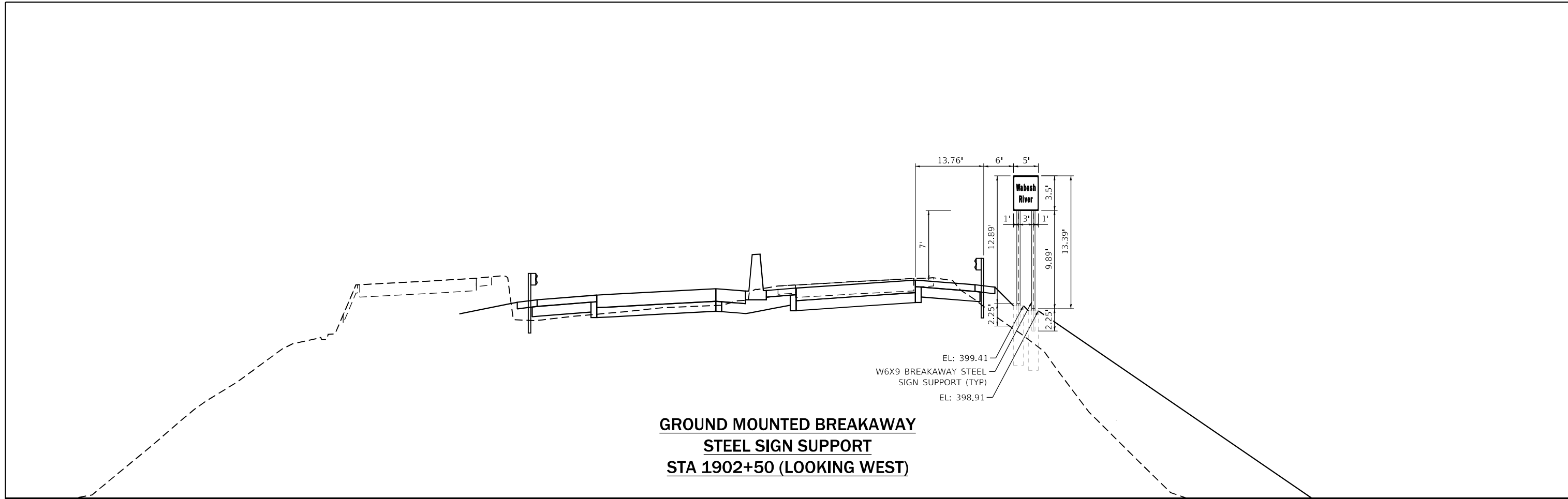

MODEL: D:\d\h\h
 FILE NAME: E:\09 E:\CAD\Drawings\1978057-1-1-1\Drawings\1978057-1-1-1.dwg



USER NAME = r0ber	DESIGNED - RC	REVISED -
	DRAWN - RC	REVISED -
PLOT SCALE = 20,0000 * / in.	CHECKED - ST	REVISED -
PLOT DATE = 6-7-2022	DATE - 6/30/2023	REVISED -

**STATE OF ILLINOIS
DEPARTMENT OF TRANSPORTATION**

**SIGN ELEVATION DETAILS
I-64 OVER WABASH RIVER**

SCALE: N.T.S. SHEET 2 OF 3 SHEETS STA. TO STA.

F.A.I. RTE.	SECTION	COUNTY	TOTAL SHEETS	SHEET NO.
64	(97-2) B-5	WHITE	578	168
CONTRACT NO. 78057				
ILLINOIS FED. AID PROJECT FAI 64/WABASH RIVER				

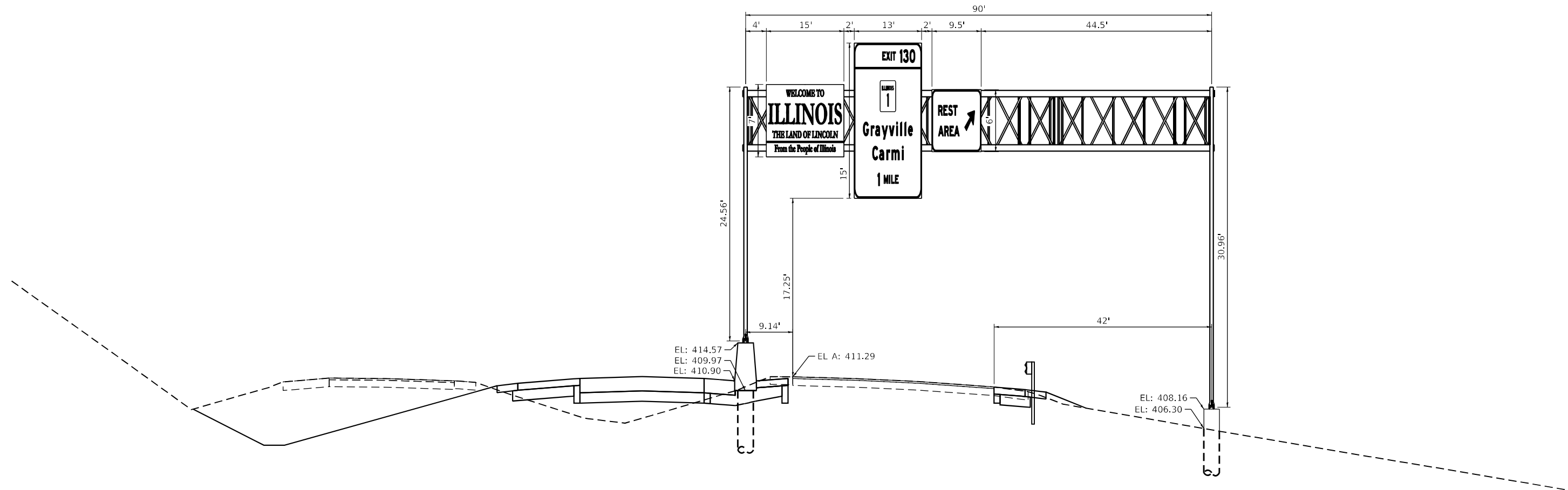

OVERHEAD SIGN STRUCTURE, SPAN TYPE
STA 1872+00 (LOOKING WEST)
S.N. 9S097164L130.5

MODEL: D:\dgn\11
 FILE NAME: E:\03\11\CADD_Sheets\0978057-1-11-23\sign_elevation.dgn

LIN ENGINEERING, LTD.
 Consulting Engineers
 Westmont, Illinois

USER NAME = r0ber	DESIGNED - RC	REVISED -
	DRAWN - RC	REVISED -
PLOT SCALE = 20,0000 * / in.	CHECKED - ST	REVISED -
PLOT DATE = 6-7-2022	DATE - 6/30/2023	REVISED -

STATE OF ILLINOIS
DEPARTMENT OF TRANSPORTATION

SIGN ELEVATION DETAILS
I-64 OVER WABASH RIVER

SCALE: N.T.S. SHEET 3 OF 3 SHEETS STA. TO STA.

F.A.I. RTE.	SECTION	COUNTY	TOTAL SHEETS	SHEET NO.
64	(97-2) B-5	WHITE	578	169
CONTRACT NO. 78057				
ILLINOIS FED. AID PROJECT FAI 64/WABASH RIVER				

GENERAL NOTES

DESIGN: AASHTO Standard Specifications for Structural Supports for Highway Signs, Luminaires and Traffic Signals. ("AASHTO Specifications")

CONSTRUCTION: Current (at time of letting) Illinois Department of Transportation Standard Specifications for Road and Bridge Construction, Supplemental Specifications and Special Provisions. ("Standard Specifications")

LOADING: 90 M.P.H. WIND VELOCITY

WALKWAY LOADING: Dead load plus 500 lbs. concentrated live load.

DESIGN STRESSES:
Field Units
f'c = 3,500 p.s.i.
fy = 60,000 p.s.i. (reinforcement)

WELDING: All welds to be continuous unless otherwise shown. All welding to be done in accordance with current AWS D1.1 and D1.2 Structural Welding Codes (Steel and Aluminum) and the Standard Specifications.

MATERIALS: Aluminum Alloys as shown throughout plans. All Structural Steel Pipe shall be ASTM A53 Grade B or A500 Grade B or C. If A500 pipe is substituted for A53, then the outside diameter shall be as detailed and wall thickness greater than or equal to A53. All Structural Steel Plates and Shapes shall conform to AASHTO M270 Gr. 36, Gr. 50 or Gr. 50W*. Stainless steel for shims, sleeves and handhole covers shall be ASTM A240, Type 302 or 304, or another alloy suitable for exterior exposure and acceptable to the Engineer.

The steel pipe and stiffening ribs at the base plate for the column shall have a minimum longitudinal Charpy V-Notch (CVN) energy of 15 lb.-ft. at 40° F. (Zone 2) before galvanizing.

FASTENERS FOR ALUMINUM TRUSSES: All bolts noted as "high strength" must satisfy the requirements of AASHTO M164 (ASTM A325), or approved alternate, and must have matching lock nuts. Threaded studs for splices (if Members interfere) must satisfy the requirements of ASTM A449, ASTM A193, Grade B7, or approved alternate, and must have matching lock nuts. Bolts and lock nuts not required to be high strength must satisfy the requirements of ASTM A307. All bolts and lock nuts must be hot dip galvanized per AASHTO M232. The lock nuts must have nylon or steel inserts. A stainless steel flat washer conforming to ASTM A240 Type 302 or 304, is required under both head and nut or under both nuts where threaded studs are used. High strength bolt installation shall conform to Article 505.04 (f) (2)d of the IDOT Standard Specifications for Road and Bridge Construction. Rotational capacity ("ROCAP") testing of bolts will not be required.

U-BOLTS AND EYEBOLTS: U-Bolts and Eyebolts must be produced from ASTM A276 Type 304, 304L, 316 or 316L, Condition A, cold finished stainless steel, or an equivalent material acceptable to the Engineer. All nuts for U-Bolts and Eyebolts must be lock nuts equivalent to ASTM A307 with nylon or steel inserts and hot dip galvanized per AASHTO M232. A stainless steel flat washer conforming to ASTM A240, Type 302 or 304, is required under each U-Bolt and Eyebolt lock nut.

GALVANIZING: All Steel Grating, Plates, Shapes and Pipe shall be Hot Dip Galvanized after fabrication in accordance with AASHTO M111. Painting is not permitted.

ANCHOR RODS: Shall conform to ASTM F1554 Gr. 105.

CONCRETE SURFACES: All concrete surfaces above an elevation 6" below the lowest final ground line at each foundation shall be cleaned and coated with Concrete Sealer in accordance with the Standard Specifications.

REINFORCEMENT BARS: Reinforcement Bars designated (E) shall be epoxy coated in accordance with the Standard Specifications.

FOUNDATIONS: The contract unit price for Concrete Foundations and Drilled Shaft Concrete Foundations shall include reinforcement bars complete in place.

TOTAL BILL OF MATERIAL

ITEM	UNIT	TOTAL
OVERHEAD SIGN STRUCTURE SPAN TYPE I-A	Foot	
OVERHEAD SIGN STRUCTURE SPAN TYPE II-A	Foot	90
OVERHEAD SIGN STRUCTURE SPAN TYPE III-A	Foot	
OVERHEAD SIGN STRUCTURE WALKWAY TYPE A	Foot	
CONCRETE FOUNDATIONS	Cu. Yds	
DRILLED SHAFT CONCRETE FOUNDATIONS	Cu. Yds	26.8

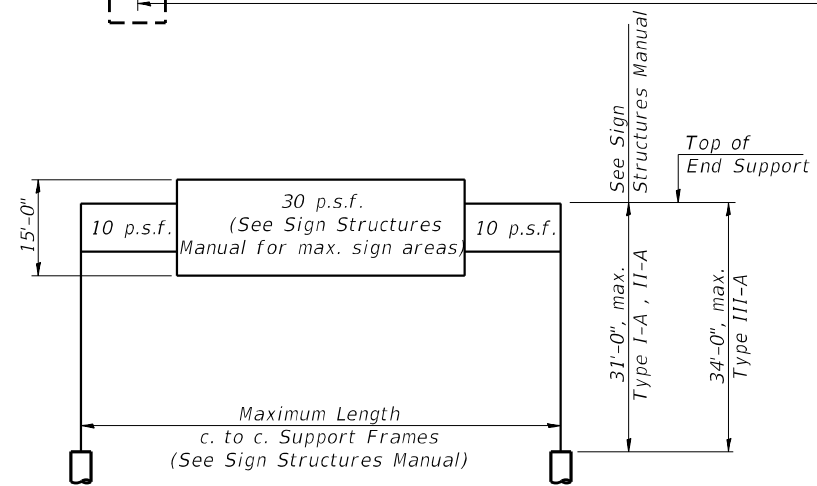
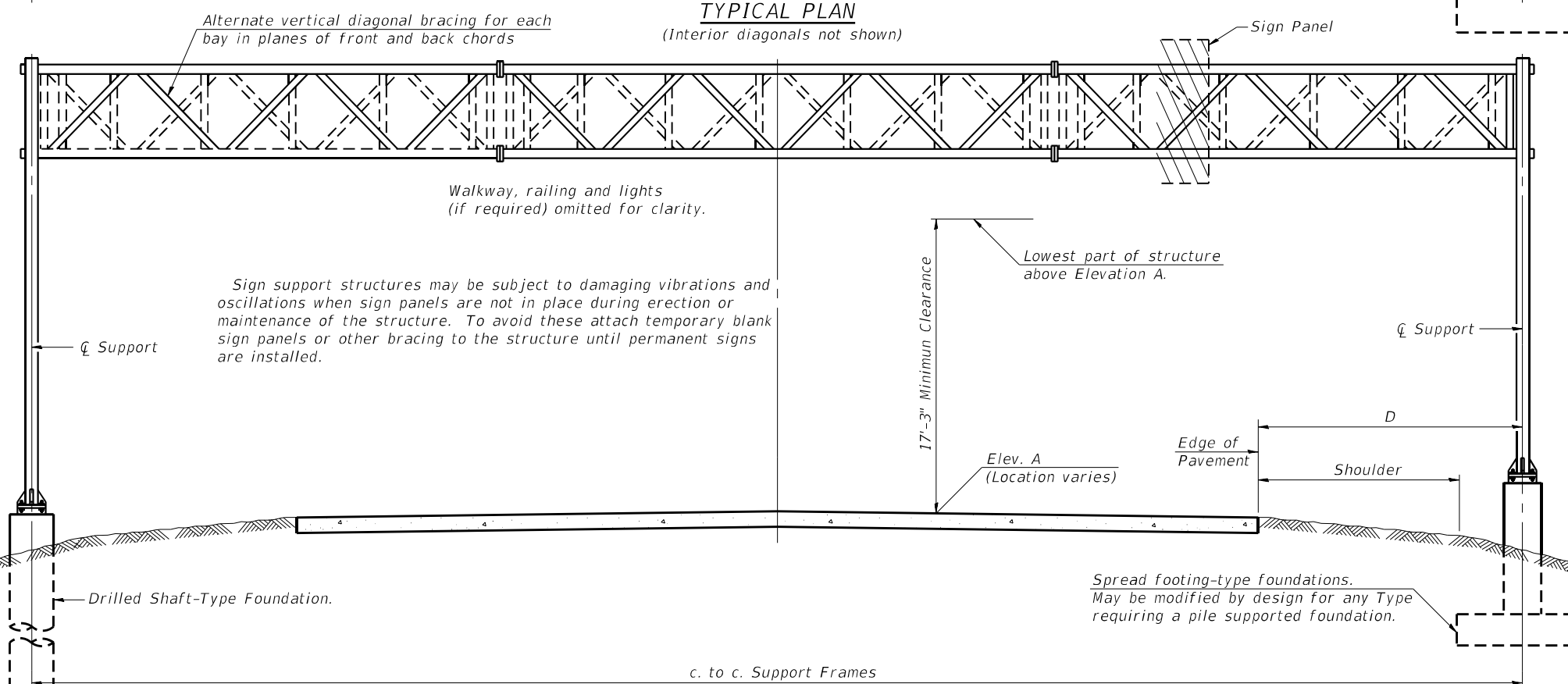
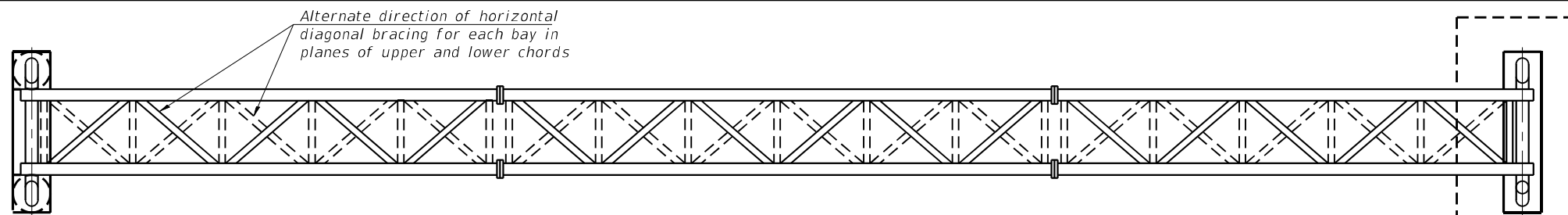

TYPICAL ELEVATION
(Looking at Face of Signs**)

Structure Number	Station	Design Truss Type	c. to c. Supports	Elev. A	Dim. D	Height of Tallest Sign	Total Sign Area
95097164L130.5	1872+00	Type II-A	90 ft	411.29'	42'-0"	15'-0"	357 sq ft

**Looking upstation for structures with signs both sides.

* If M270 Gr. 50W (M222) steel is proposed, chemistry for plate to be used shall first be approved by the Engineer as suitable for galvanizing and welding.

DESIGN WIND LOADING DIAGRAM
Parameters shown are basis for I.D.O.T. Standards and Sign Manual Tables. Installations not within dimensional limits shown require special analysis for all components.

MODEL: Default
FILE NAME: E:\0816\1\Struct\Final_Design\CADD_Sheets\78057-01.dgn

05-A-1 2-17-2017

LE LIN ENGINEERING, LTD.
Consulting Engineers
Springfield, Illinois

USER NAME =	DESIGNED -	REVISED -
PLOT SCALE =	CHECKED -	REVISED -
PLOT DATE = 6/30/2023	DRAWN -	REVISED -
	CHECKED -	REVISED -

STATE OF ILLINOIS
DEPARTMENT OF TRANSPORTATION

OVERHEAD SIGN STRUCTURES - GENERAL PLAN & ELEVATION - ALUMINUM TRUSS & STEEL SUPPORTS

SHEET 1 OF 10 SHEETS

F.A.I. RTE.	SECTION	COUNTY	TOTAL SHEETS	SHEET NO.
64	(97-2) B-5	WHITE	578	170
CONTRACT NO. 78057				

ILLINOIS FED. AID PROJECT FAI 64/WABASH RIVER

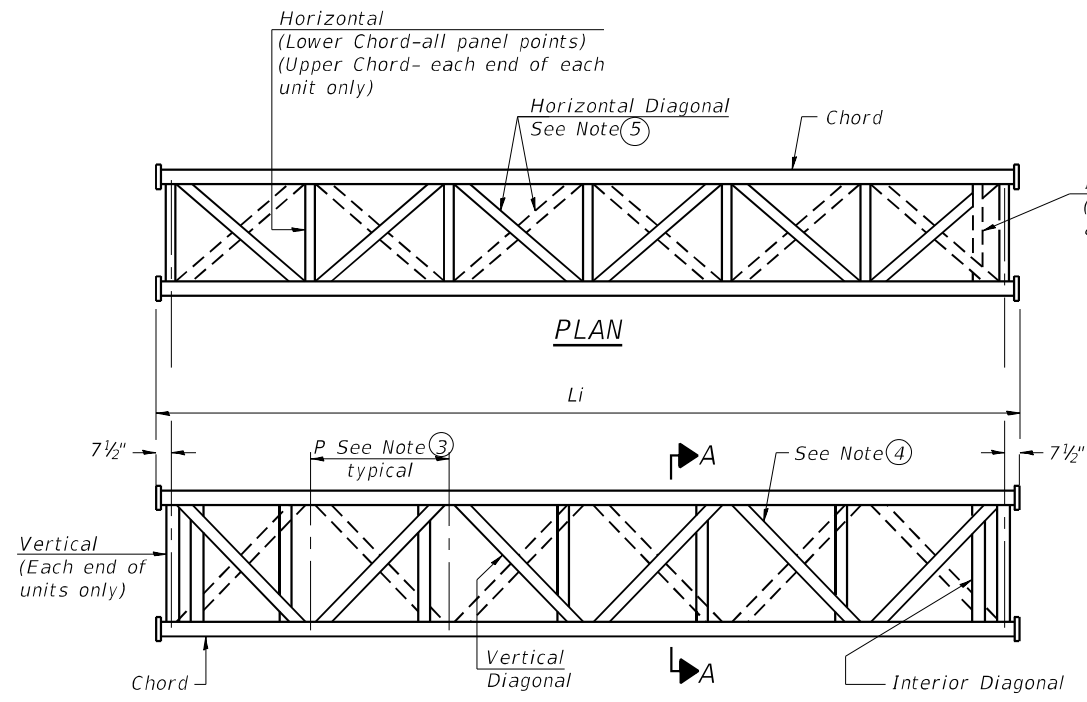

**ELEVATION
TYPICAL INTERIOR UNIT**
Even number of panels/interior unit required.

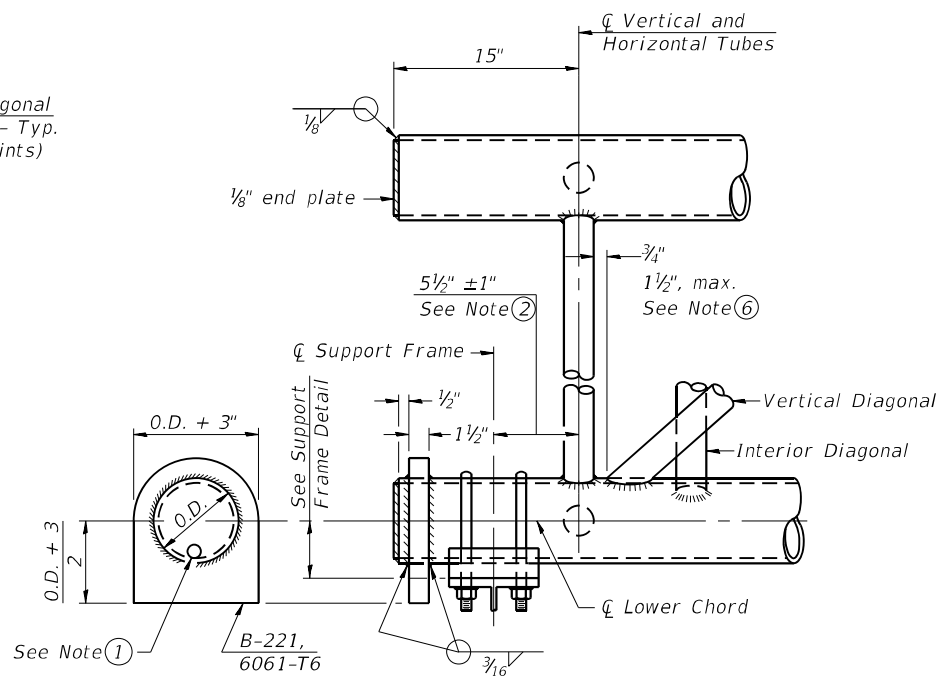

SUPPORT END DETAIL FOR EXTERIOR UNIT

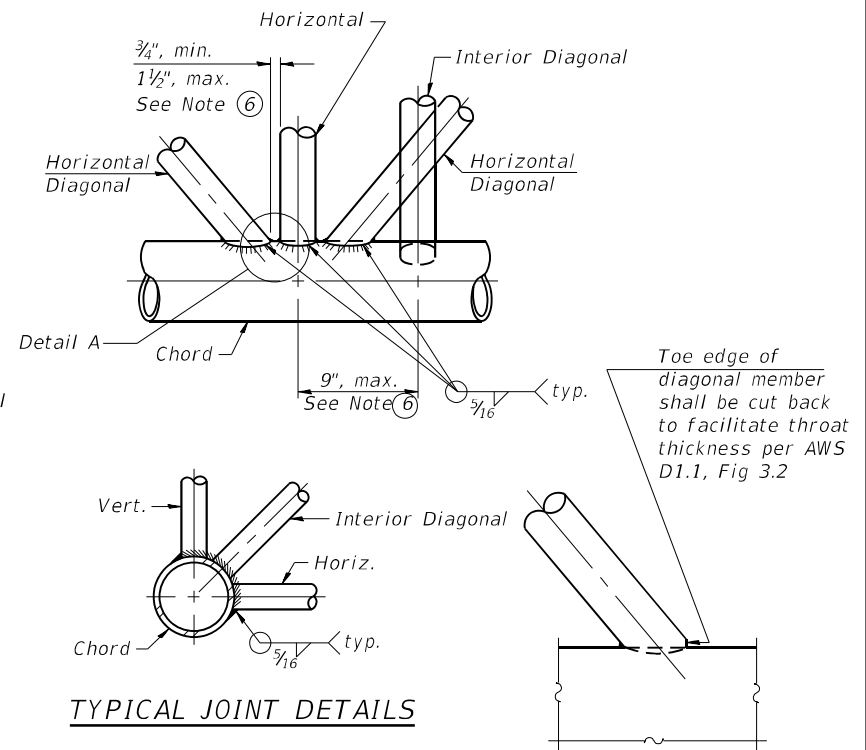

TYPICAL JOINT DETAILS

DETAIL A

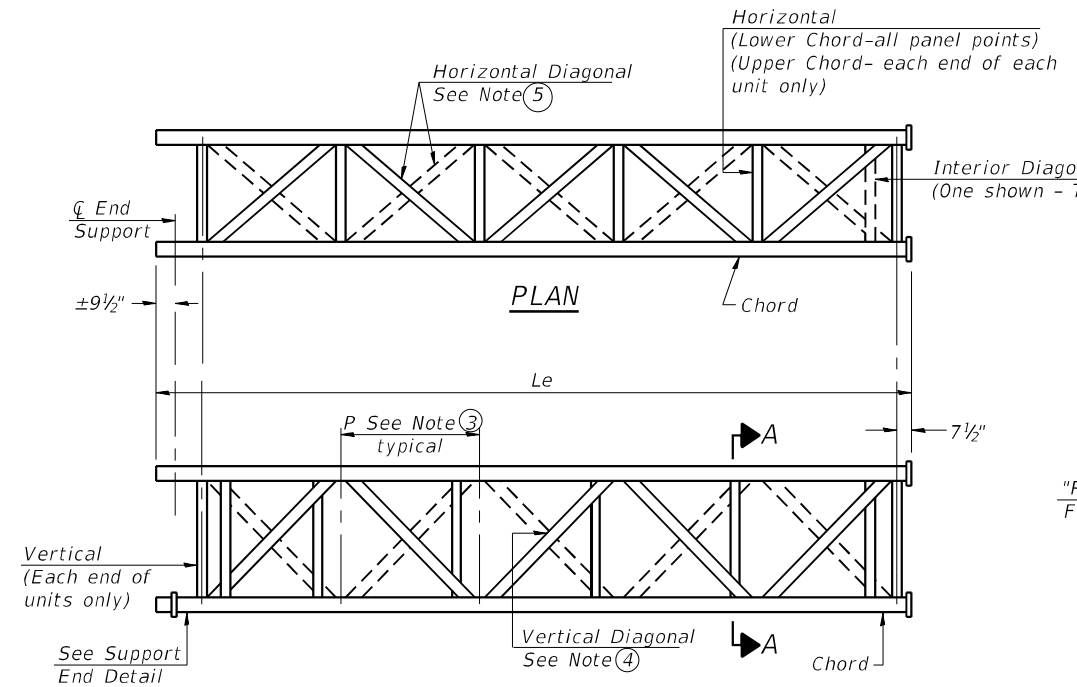

**ELEVATION
TYPICAL EXTERIOR UNIT**
Even or odd number of panels/exterior units allowed.

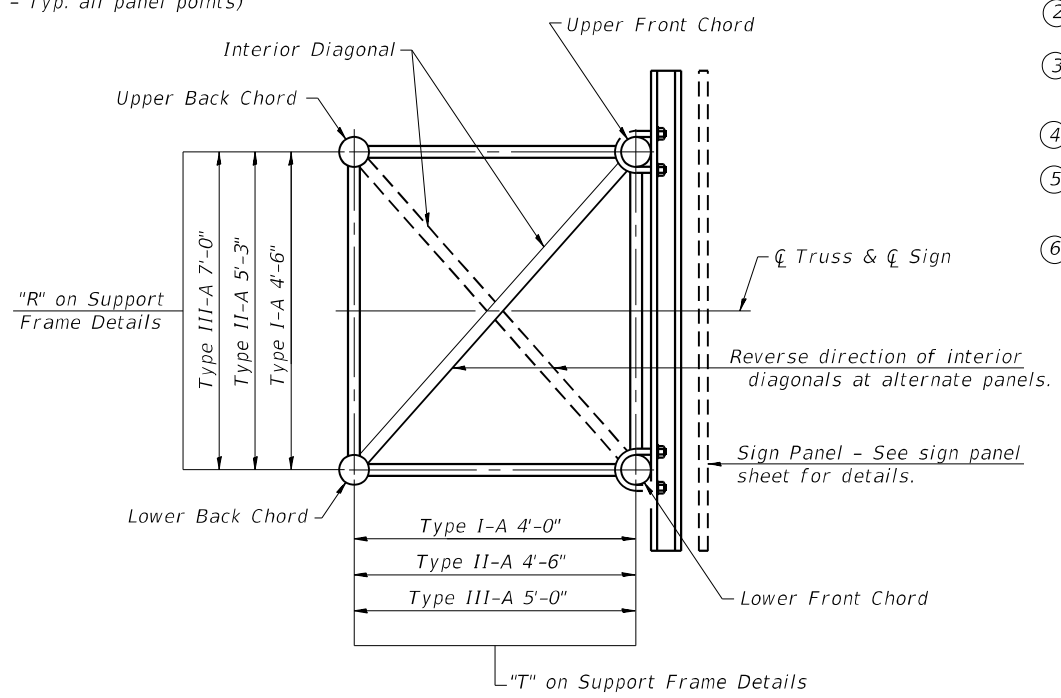

SECTION A-A

- ① Contractor may alternatively use standard aluminum drive-fit cap to close end. 1/2" Ø drain hole in end plate/drive-fit cap. (Typ. at ends of all chords)
- ② 5 1/2" end dimension may vary by ±1" to provide uniform panel spacing (P).
- ③ Panel spacing (P) shall be uniform for entire truss and between 4'-0" and 5'-0" for Type I-A or 4'-0" and 5'-6" for Types II-A and III-A.
- ④ Vertical Diagonals in front and back face shall alternate.
- ⑤ Hidden lines show wind bracing alternates direction between planes of top and bottom chords.
- ⑥ All diagonals shall be detailed for minimum offset from the panel point based on the following: Offset shall be such as to provide a 3/4" minimum to 1 1/2" maximum clearance between any diagonal and any horizontal or vertical member, and to provide clearance for U-bolt connections of signs or walkway brackets.

MODEL: Default
FILE NAME: E:\0816\1\Struct\Final Design\CADD\CADD_Sheets\78057-02.dgn

05-A-2

2-17-2017

LE LIN ENGINEERING, LTD.
Consulting Engineers
Springfield, Illinois

USER NAME =	DESIGNED -	REVISED -
PLOT SCALE =	CHECKED -	REVISED -
PLOT DATE = 6/30/2023	DRAWN -	REVISED -
	CHECKED -	REVISED -

**STATE OF ILLINOIS
DEPARTMENT OF TRANSPORTATION**

**OVERHEAD SIGN STRUCTURES - ALUMINUM TRUSS
DETAILS FOR TRUSS TYPES I-A, II-A AND III-A**

SHEET 2 OF 10 SHEETS

F.A.I. RTE.	SECTION	COUNTY	TOTAL SHEETS	SHEET NO.
64	(97-2) B-5	WHITE	578	171
CONTRACT NO. 78057				

ILLINOIS FED. AID PROJECT FAI 64/WABASH RIVER

TRUSS UNIT TABLE

Structure Number	Station	Design Truss Type	Exterior Units (2)			Interior Unit				Upper & Lower Chord		Verticals; Horizontal; Vertical, Horizontal, and Interior Diagonals		Camber at Midspan	Splicing Flange					
			No. Panels per Unit	Unit Lgth.(Le)	Panel Lgth.(P)	No. Req'd.	No. Panels per Unit	Unit Lgth.(Li)	Panel Lgth.(P)	O.D.	Wall	O.D.	Wall		Bolts		Weld Sizes		A	B
															No./Splice	Dia.	W	WI		
9S097164L130.5	1872+00	Type II-A	5	28'-11 1/2"	5'-5"	1	6	33'-9"	5'-5"	5 1/2"	5/16"	3"	3/16"	2.5"	6	7/8"	3/8"	1/4"	9 1/4"	12 1/4"

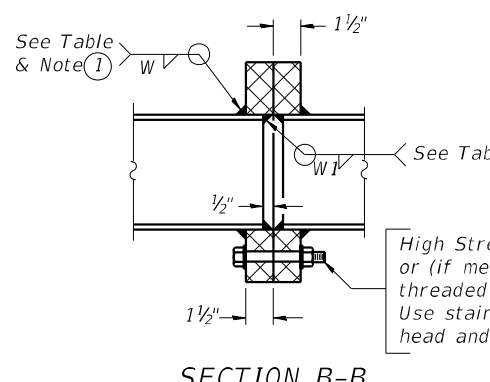

High Strength bolts with locknuts or (if members interfere) threaded studs with 2 locknuts. Use stainless steel washers under head and nut. See table.

① Splicing Flanges shall be attached to each truss unit with the truss shop assembled to camber shown. Truss units shall be in proper alignment and flange surfaces shall be shop bolted into full contact before welding. Sufficient external welds or tacks shall be made to secure flanges until remaining welds are made after disassembly. Adjacent flanges shall be "match marked" to insure proper field assembly.

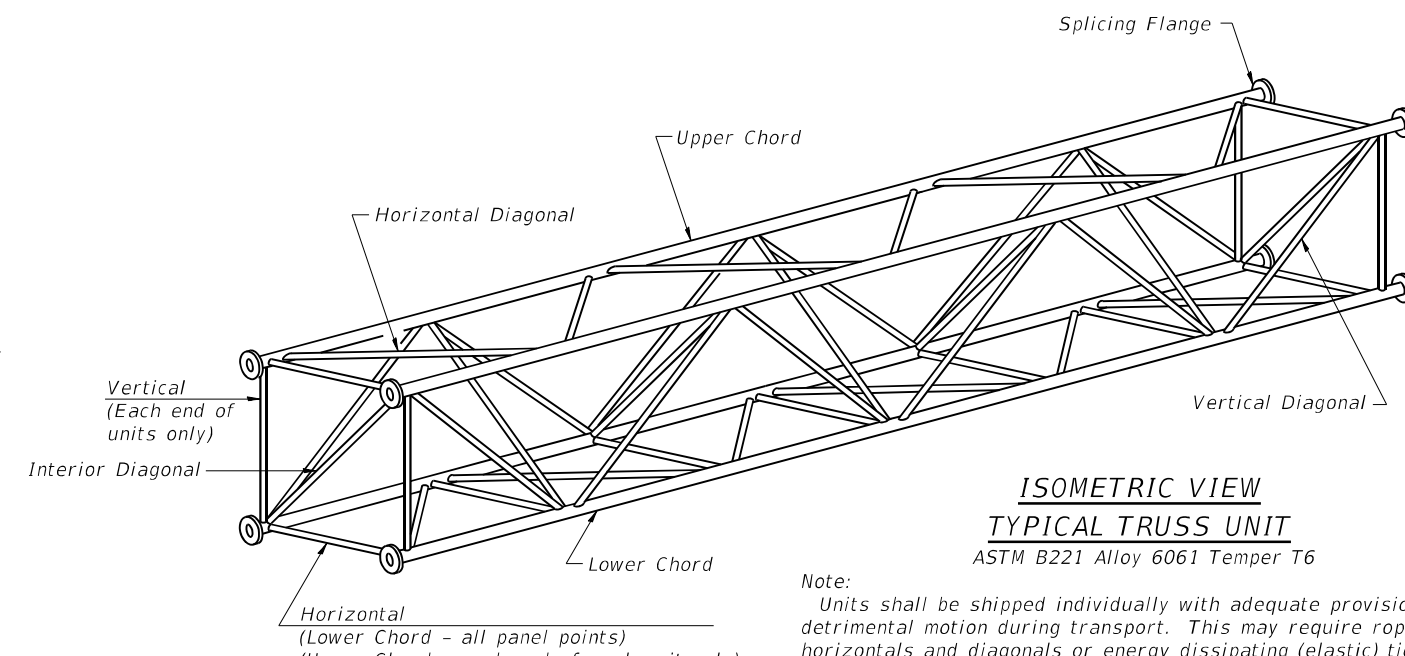

ISOMETRIC VIEW
TYPICAL TRUSS UNIT
ASTM B221 Alloy 6061 Temper T6

Note:
Units shall be shipped individually with adequate provision to prevent detrimental motion during transport. This may require ropes between horizontals and diagonals or energy dissipating (elastic) ties to the vehicle. The Contractor is responsible for maintaining the configuration and protection of the units.

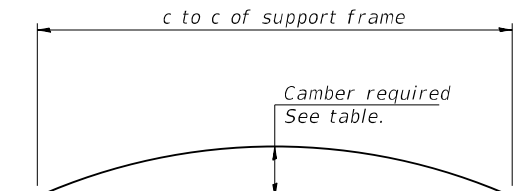

CAMBER DIAGRAM

Camber curve shown is theoretical. Actual camber attained by slope changes at splices between units.

CAMBER ATTAINMENT EXAMPLES:

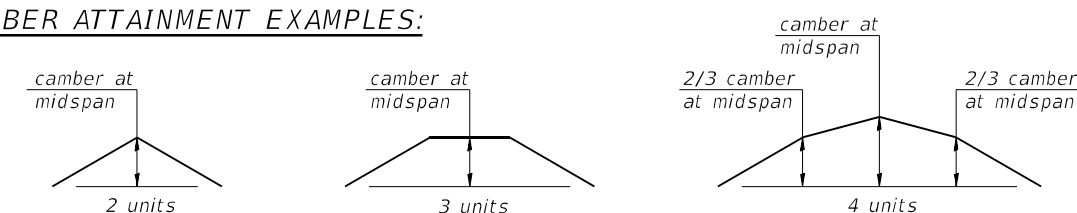

Camber shown is for fabrication only, measured with truss fully supported. (No-load condition)

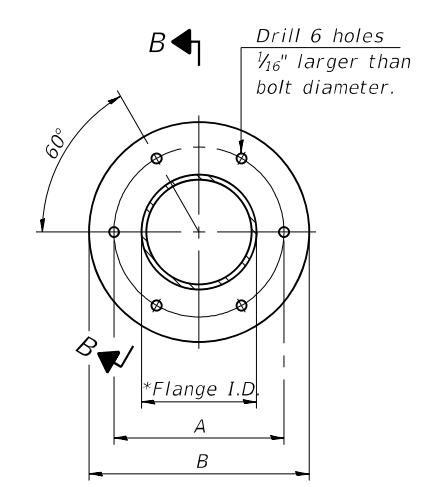

TRUSS TYPES I-A, II-A, & III-A

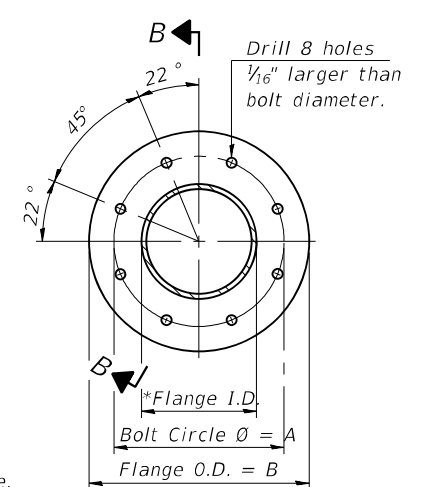

TRUSS TYPES II-A & III-A
SPlicing FLANGES

ASTM B221, Alloy 6061-T6 or ASTM B209, Alloy 6061-T651
*To fit O.D. of Chord with maximum gap of 1/16".

MODEL: Default
FILE NAME: E:\0816\1\Struct\Final_Design\CADD\CADD_Sheets\78057-03.dgn

054-A-2 2-17-2017



USER NAME =	DESIGNED -	REVISED -
	CHECKED -	REVISED -
PLOT SCALE =	DRAWN -	REVISED -
PLOT DATE = 6/30/2023	CHECKED -	REVISED -

STATE OF ILLINOIS
DEPARTMENT OF TRANSPORTATION

OVERHEAD SIGN STRUCTURES - ALUMINUM TRUSS DETAILS
FOR TRUSS TYPES I-A, II-A AND III-A

SHEET 3 OF 10 SHEETS

F.A.I. RTE.	SECTION	COUNTY	TOTAL SHEETS	SHEET NO.
64	(97-2) B-5	WHITE	578	172
CONTRACT NO. 78057				
ILLINOIS FED. AID PROJECT FAI 64/WABASH RIVER				

5/16" Ø stainless steel
U-bolt with hot dip galvanized
locknuts and stainless steel washers,
typ. 3/8" Ø holes in 2 1/2" Ø tube

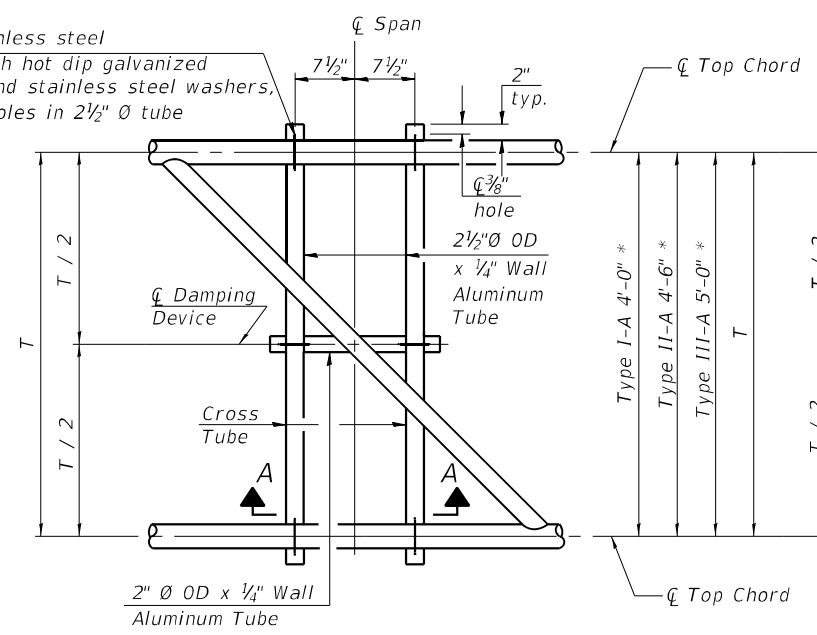

PLAN DETAIL "A"
☐ Span between Panel Points

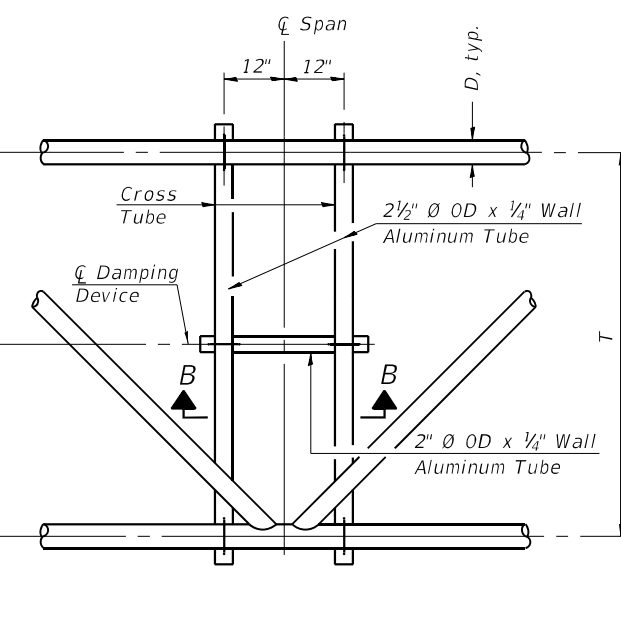

PLAN DETAIL "B"
☐ Span at Panel Point

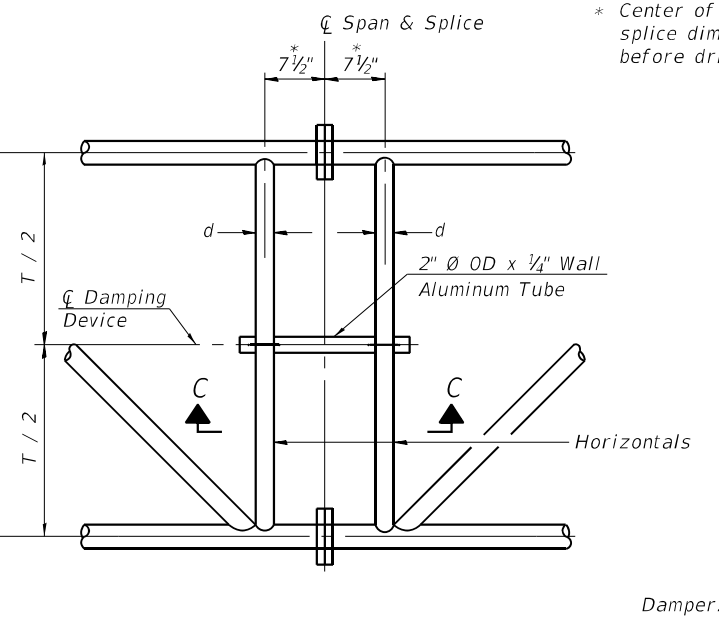

PLAN DETAIL "C"
☐ Span at ☐ Chord Splice

* Center of horizontal to center of splice dimension may vary. Verify before drilling holes in mounting tube.

NOTES

Damper: One damper per truss. (31 lbs. minimum Stockbridge-Type Aluminum - 29" minimum between ends of weights) Cost included in Overhead Sign Structure...

Materials: Materials: Aluminum tubes shall be ASTM B221 alloy 6061 temper T6. Cost included in Overhead Sign Structure...

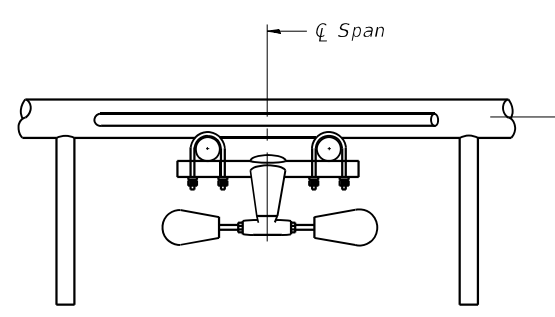

SECTION A-A

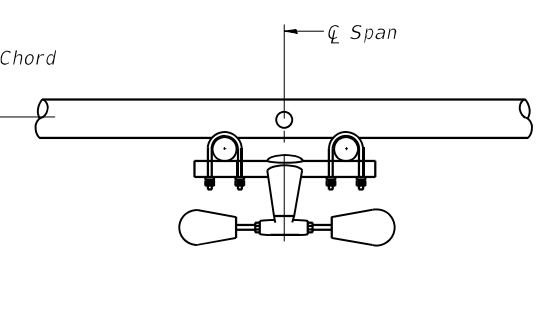

SECTION B-B

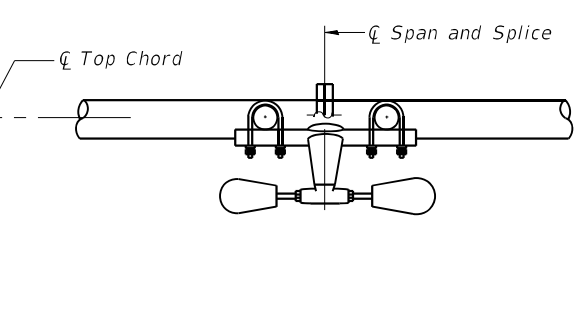

SECTION C-C

5/16" Ø stainless steel
U-bolt with hot dip galvanized
locknuts and stainless steel washers,
typ. 3/8" Ø holes in mounting tube

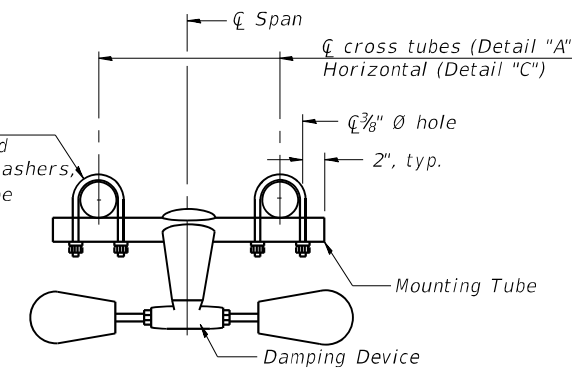

**TRUSS DAMPING
DEVICE CONNECTION DETAIL**
(Typical)

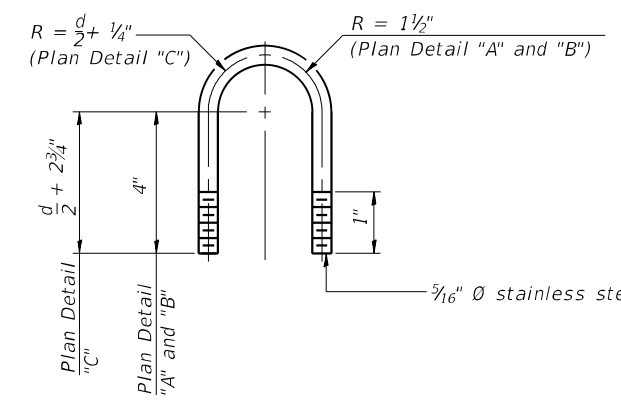

**DAMPING DEVICE MOUNTING
TUBE U-BOLT DETAIL**
(Typical)

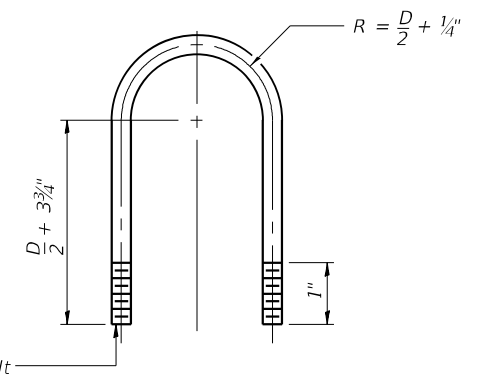

**TOP CHORD TO CROSS TUBE
U-BOLT DETAIL**
(Typical - Detail "A" and "B")

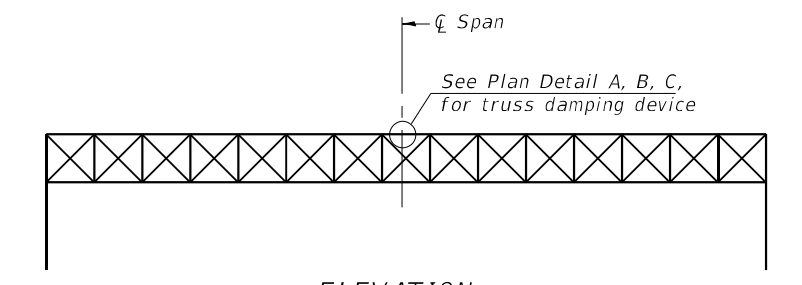

ELEVATION
Aluminum Overhead
Sign Truss

MODEL: Default
FILE NAME: E:\0816\1\Struct\Final_Design\CADD_Sheets\78057-04.dgn

05-A-D

2-17-2017

LE LIN ENGINEERING, LTD.
Consulting Engineers
Springfield, Illinois

USER NAME =	DESIGNED -	REVISED -
PLOT SCALE =	CHECKED -	REVISED -
PLOT DATE = 6/30/2023	DRAWN -	REVISED -
	CHECKED -	REVISED -

**STATE OF ILLINOIS
DEPARTMENT OF TRANSPORTATION**

**OVERHEAD SIGN STRUCTURE
DAMPING DEVICE**

SHEET 4 OF 10 SHEETS

F.A.I. RTE.	SECTION	COUNTY	TOTAL SHEETS	SHEET NO.
64	(97-2) B-5	WHITE	578	173
CONTRACT NO. 78057				
ILLINOIS FED. AID PROJECT FAI 64/WABASH RIVER				

3/4" Ø stainless steel U-bolt.
Provide two washers and two hexagon locknuts. (4)
1 3/16" x 2" slots on 10" Ø pipe.
(4 slots required per pipe)

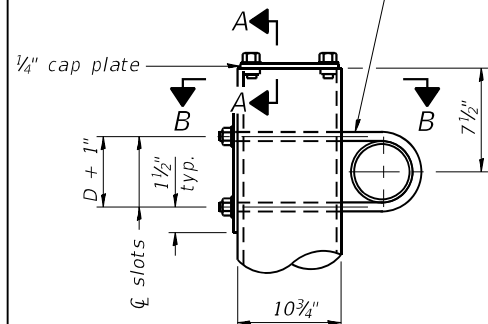

DETAIL A

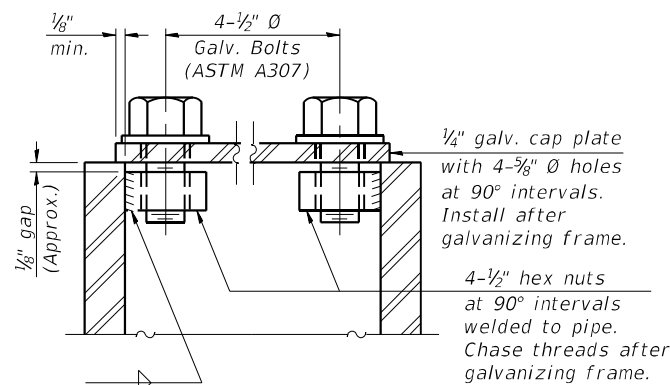

SECTION A-A

As an alternate to bolts, may use galvanized drive-fit caps installed after galvanizing frame.

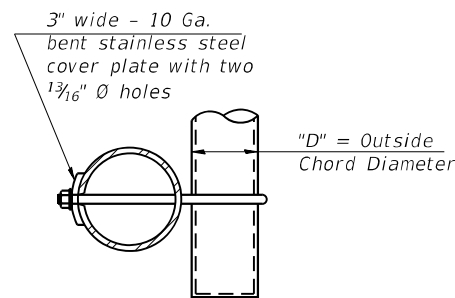

SECTION B-B

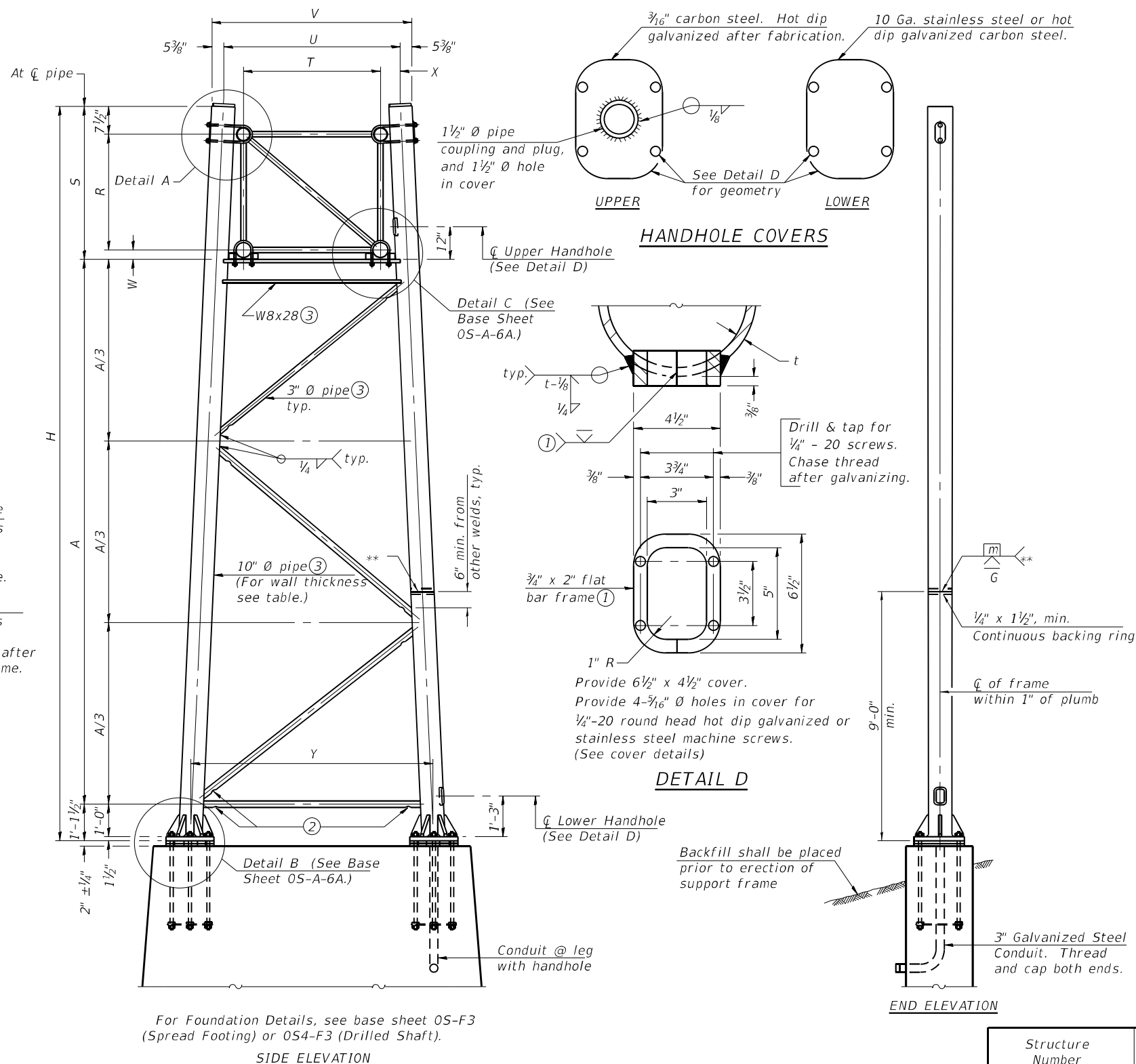

For Foundation Details, see base sheet OS-F3 (Spread Footing) or OS4-F3 (Drilled Shaft).

SIDE ELEVATION

Truss Type	Dimensions							
	R	S	T	U	V	W	X	Y
I-A	4'-6"	5'-5 1/2"	4'-0"	5'-6"	6'-4 3/4"	4"	9"	8'-3"
II-A (5)	5'-3"	6'-3 1/4"	4'-6"	6'-1"	6'-11 3/4"	4 3/4"	9 1/2"	8'-3"

10" Ø PIPE TRUSS SUPPORT FRAME

** One butt welded joint is allowed only on one post per support frame. If used, weld procedure must be pre-approved by Engineer and joint shall receive 100% RT or UT (tension criteria) at Contractor's expense.

Support Design Loads: See Base Sheet OS-A-1 for design and loading criteria.
Load combinations checked include deadload plus:
a) 100% wind normal to sign, 20% parallel to sign
b) 60% wind normal to sign, 30% parallel to sign

- In lieu of fabricated handhole frame as shown, may cut from 2" plate (rolling direction vertical). All cut faces to be ground to ANSI Roughness of 500µ in or less.
- Galvanizing vent holes of adequate size shall be provided on underside at each end of bracing pipes. Alternately, holes may be provided in wall of pipe column. All vent holes shall be drilled and de-burred, typ.
- Steel pipe, plate, carbon steel handhole covers and rolled sections shall be hot dip galvanized after fabrication. Painting is not permitted. See Base Sheet OS-A-1.
- See General Notes for fasteners.
- Dimensions shown are based on selection criteria in the Sign Structures Manual. Nonstandard applications must have dimensions verified or amended as appropriate.
- "H" based on 15'-0" or actual sign height, whichever is greater.

Structure Number	Station	Support		Truss Type	Pipe Wall Thickness	H (6)	A
		Left	Right				
95097164L130.5	1872+00	X		Type II-A	0.365"	24'-6 3/4"	17'-2"
95097164L130.5	1872+00		X	Type II-A	0.365"	30'-11 1/2"	23'-6 3/4"

MODEL: Default
FILE NAME: E:\0816\1\Struct\Final Design\CADD\CADD_Sheets\78057-05.dgn

05-A-6

2-17-2017

LE LIN ENGINEERING, LTD.
Consulting Engineers
Springfield, Illinois

USER NAME =	DESIGNED -	REVISED -
PLOT SCALE =	CHECKED -	REVISED -
PLOT DATE = 6/30/2023	DRAWN -	REVISED -
	CHECKED -	REVISED -

STATE OF ILLINOIS
DEPARTMENT OF TRANSPORTATION

OVERHEAD SIGN STRUCTURES
SUPPORT FRAME FOR ALUMINUM TRUSS

SHEET 5 OF 10 SHEETS

F.A.I. RTE.	SECTION	COUNTY	TOTAL SHEETS	SHEET NO.
64	(97-2) B-5	WHITE	578	174
CONTRACT NO. 78057				
ILLINOIS FED. AID PROJECT FAI 64 WABASH RIVER				

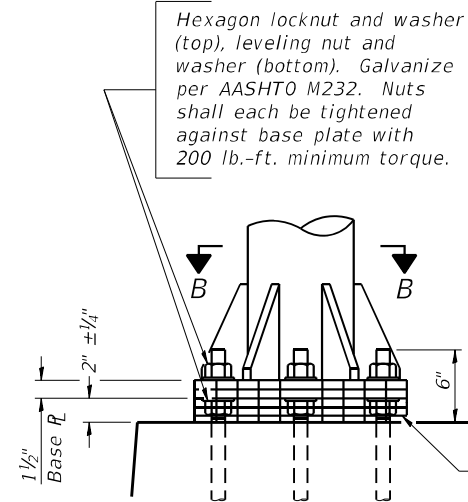

DETAIL B

Ribs shall be cut to fit slope of pipe.
 Stainless Steel Standard Grade Wire Cloth, 3" wide, 1/4" maximum opening with a minimum wire diameter of AWG. No. 16 with a minimum 2" lap. Secure to base plate after erection with 3/4" stainless steel banding.

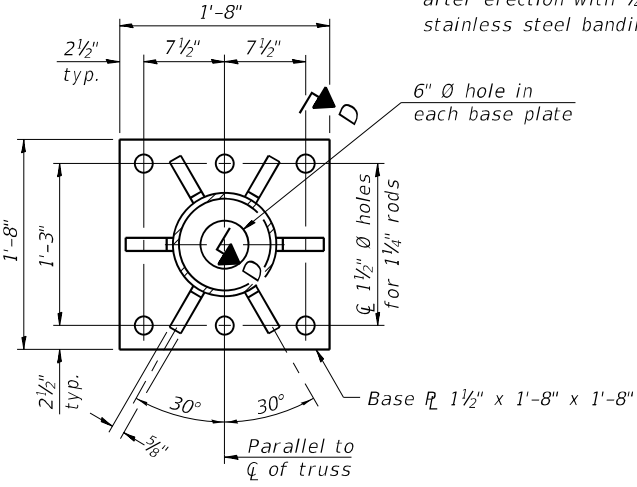

SECTION B-B

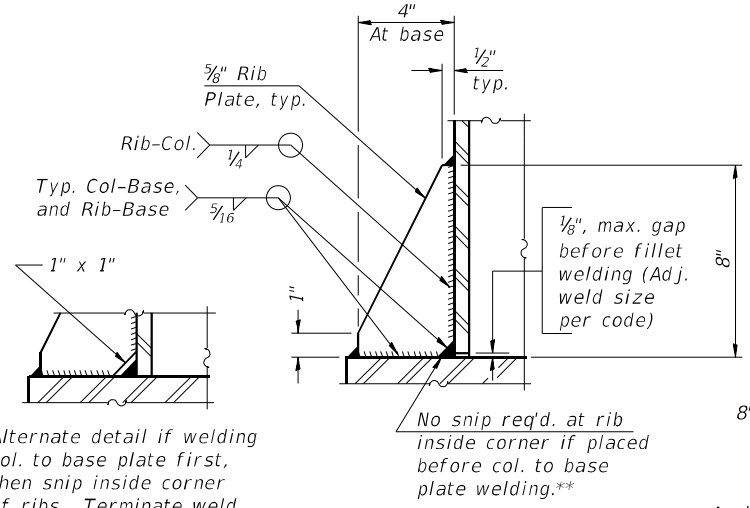

SECTION D-D

** Alternate detail if welding col. to base plate first, then snip inside corner of ribs. Terminate weld on rib 1/4" from snip.

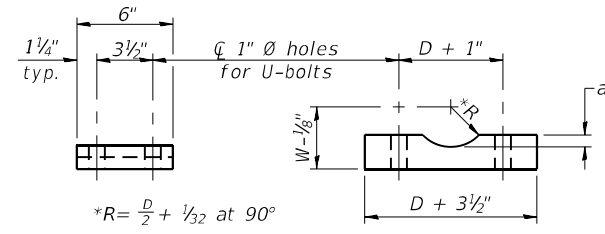

SADDLE SHIM DETAIL

ASTM B26 Alloy 356-F
 or
 ASTM B209 Alloy 6061-T651 (4 required per sign truss)

Truss Chord Nominal Dia.	a
5"	3/4"
5 1/2"	1 1/16"
6"	7/8"
6 1/2"	1 5/16"
7"	1"

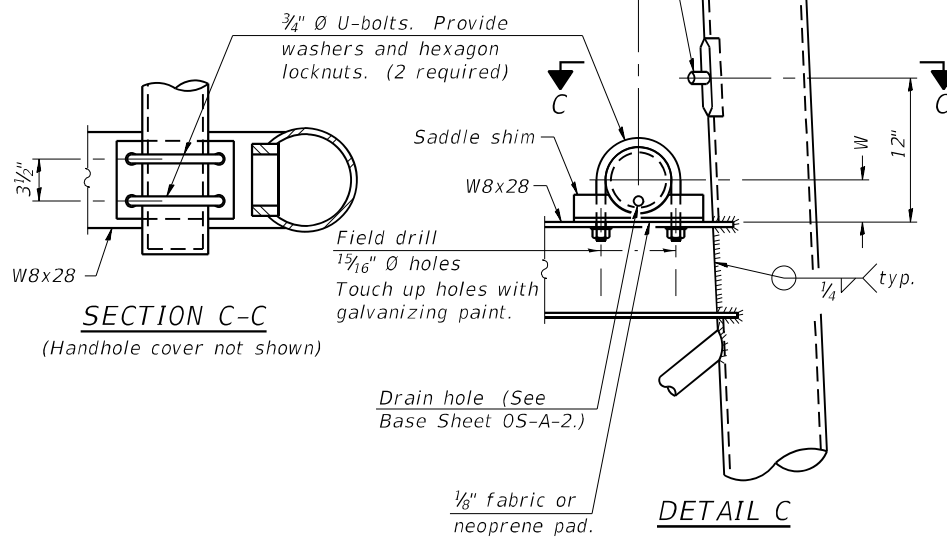

SECTION C-C

DETAIL C

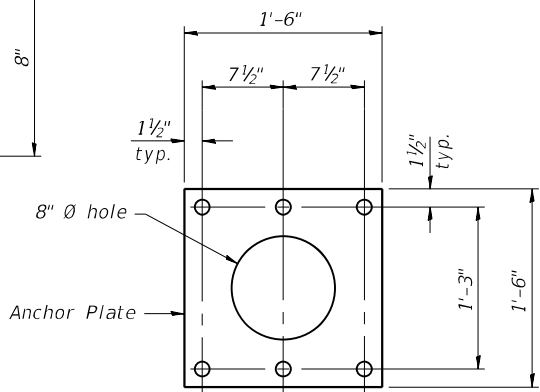

Anchor Plate

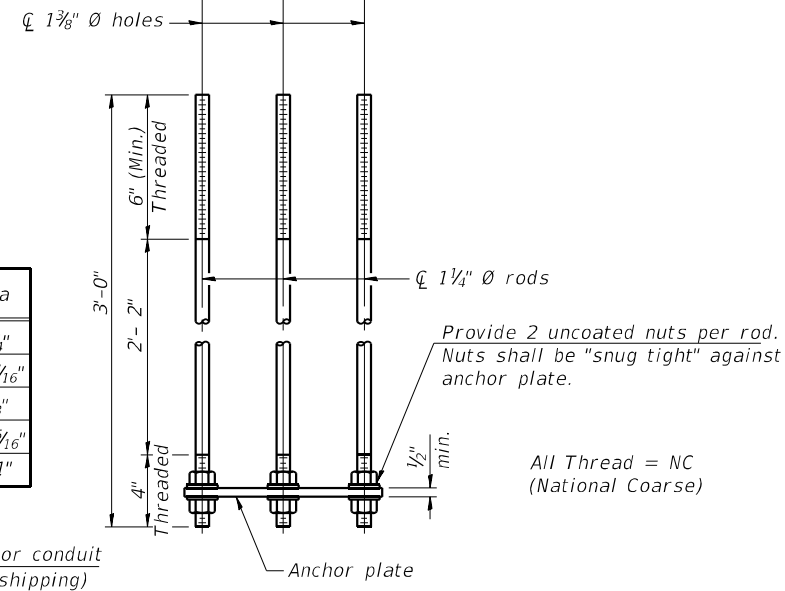

ANCHOR ROD DETAIL
 Spread Footing Foundation

Anchor rods shall conform to ASTM F1554 Grade 105. Galvanize upper 12" minimum per AASHTO M232. No welding shall be permitted on rods.

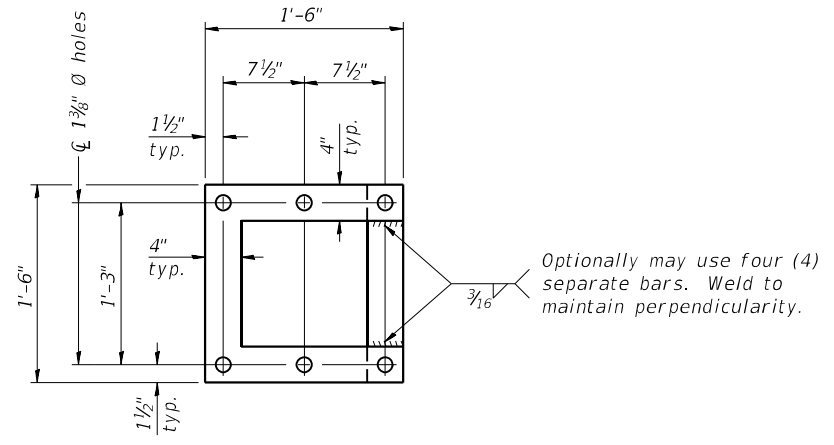

POSITIONING PLATE(S)

At each location, provide 1/4" thick positioning plate(s) and six (6) additional nuts to be used with leveling nuts to maintain anchor bolts position during concrete placement.

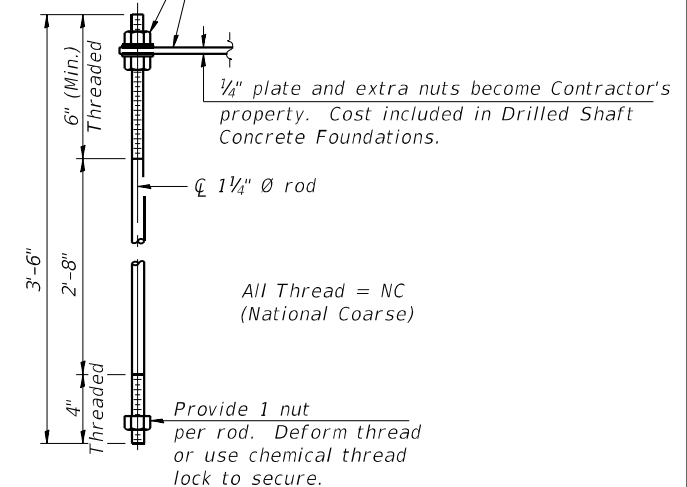

ANCHOR ROD DETAIL
 Drilled Shaft Foundation

10" Ø PIPE SUPPORT FRAME DETAILS

05-A-6A

2-17-2017

LE LIN ENGINEERING, LTD.
 Consulting Engineers
 Springfield, Illinois

USER NAME	DESIGNED	REVISIONS
	-	-
	-	-
	-	-
	-	-
	-	-
	-	-
	-	-

STATE OF ILLINOIS
DEPARTMENT OF TRANSPORTATION

OVERHEAD SIGN STRUCTURES
SUPPORT FRAME DETAILS - ALUMINUM TRUSS

F.A.I. RTE.	SECTION	COUNTY	TOTAL SHEETS	SHEET NO.
64	(97-2) B-5	WHITE	578	175
CONTRACT NO. 78057				

SHEET 6 OF 10 SHEETS

ILLINOIS FED. AID PROJECT FAI 64/MABASH RIVER

MODEL: Default
 FILE NAME: E:\0816\1\Struct\Final_Design\CADD\CADD_Sheets\78057-06.dgn
 6/28/2023 8:00:40 AM

* Anchor rod shall be ground or filed to bright metal at clamp and cable connection location.

NOTES:

The foundation dimensions shown are based on the presence of mostly cohesive soils with an average Unconfined Compressive Strength (Qu) of at least 1.25 tsf, which must be determined by previous soil investigations at the jobsite. When other conditions are indicated, the boring data will be included in the plans and the foundation dimensions shown will be the result of site specific designs.

If the conditions encountered are different than those indicated, the Contractor shall notify the Engineer to determine if the foundation dimensions need to be modified. If dimensions "B" or "F" are revised by more than 12" by the Contractor, "as-built" plans shall be prepared and submitted to the District Bureau of Operations for future reference.

No sonotubes or decomposable forms shall be used below the lower conduit entrance. Permanent metal forms or other shielding may not be left in place below that elevation without the Engineer's written permission.

Concrete shall be placed monolithically, without construction joints.

Backfill shall be placed per Article 502 of Standard Specification and prior to erection of support column.

A normal surface finish followed by a Concrete Sealer application will be required on concrete surfaces above the lowest elevation 6" below finished ground line. Cost included in Drilled Shaft Concrete Foundation.

BAR LIST - EACH FOUNDATION

Bar	Number	Size	Length	Shape
h(E)	14	#4	M less 4"	—
s(E)	Varies	#5	Varies	□
v(E)	16	#9	F less 0'-5"	—
v(E)	24	#9	F less 0'-5"	—

6" Ø and 8" Ø Support Frame
10" Ø and 12" Ø Support Frame

#4(E) bar spiral. See Side Elevation

Pipe Support Frames	cc	M	a	a/2
6" Ø	7'-0"	9'-6"	0'-11"	5 1/2"
8" Ø	7'-6"	10'-0"	1'-1 1/2"	6 3/4"
10" Ø	8'-3"	11'-3"	1'-3"	7 1/2"
12" Ø	9'-0"	12'-0"	1'-6"	9"

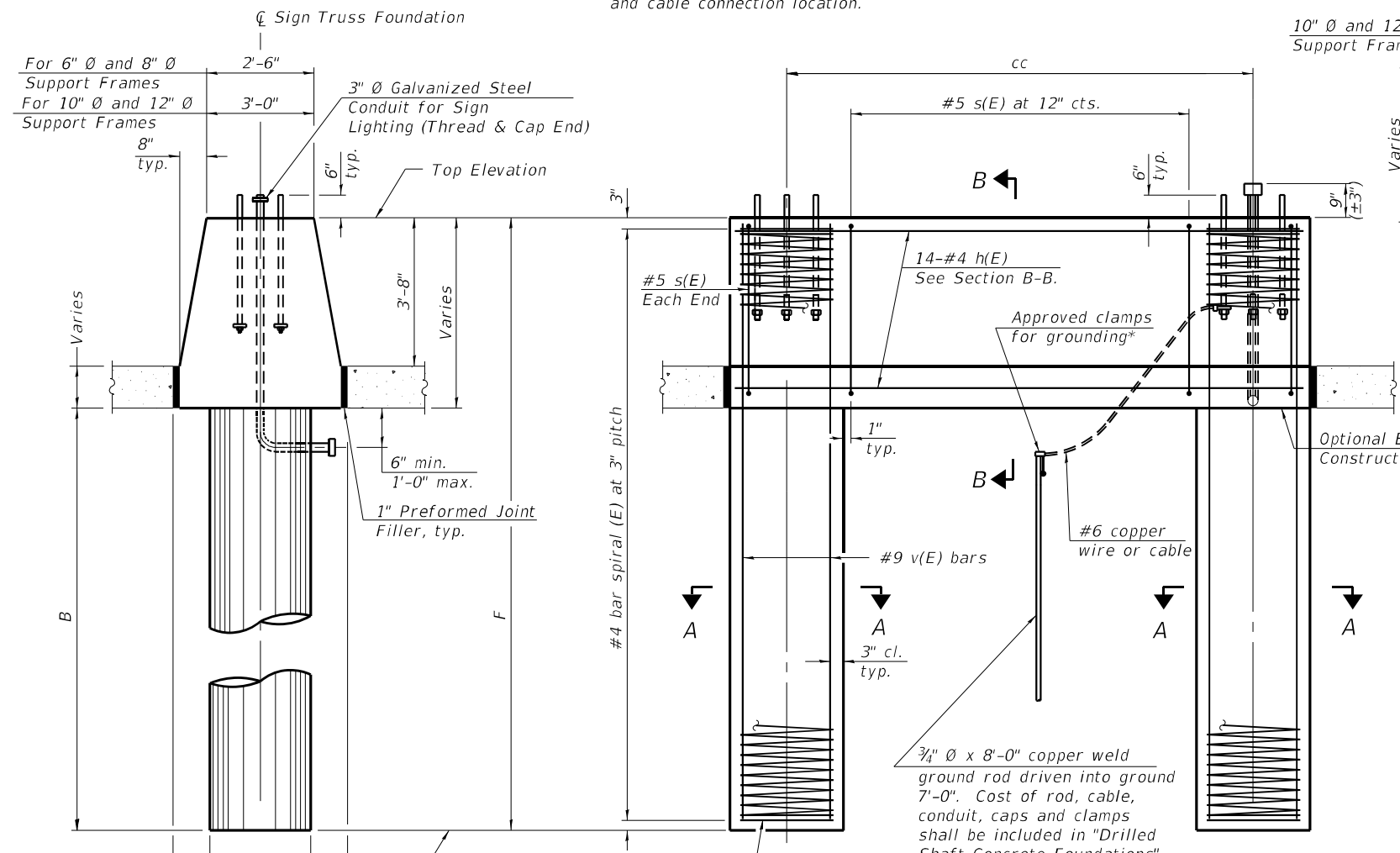

END VIEW

Support Frames	8"	2'-6"	8"
For 6" Ø and 8" Ø Support Frames			
For 10" Ø and 12" Ø Support Frames	8"	3'-0"	8"

SIDE ELEVATION
Concrete Foundation poured monolithically with no construction joint.

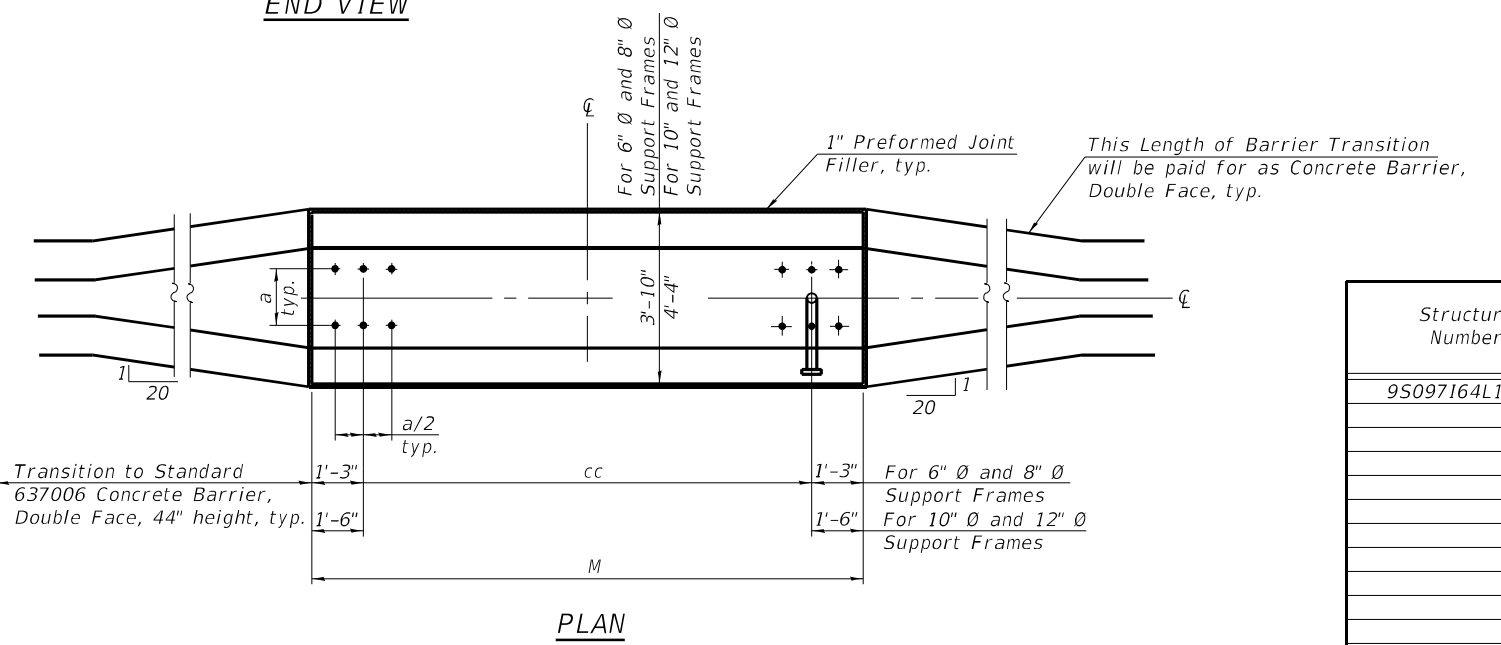
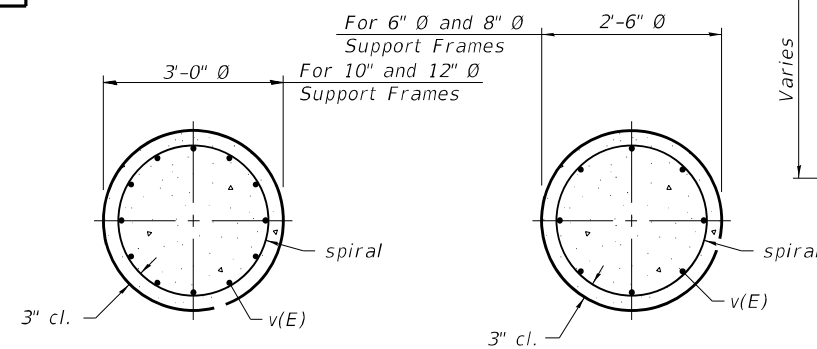

PLAN

Structure Number	Station	Left Foundation				Right Foundation				Class DS Concrete (Cu. Yds.)
		Elevation Top	Elevation Bottom	B	F	Elevation Top	Elevation Bottom	B	F	
9S097164L130.5	1872+00	414.57'	392.47'	17'-6"	22'-1 1/4"					16.5

MODEL: Default
FILE NAME: E:\0816\1\Struct\Final Design\CADD\CADD_Sheets\78057-07.dgn

054-MED

4-1-2020

LE LIN ENGINEERING, LTD.
Consulting Engineers
Springfield, Illinois

USER NAME	DESIGNED	REVISIONS
	DESIGNED -	REVISIONS -
	CHECKED -	REVISIONS -
	DRAWN -	REVISIONS -
	CHECKED -	REVISIONS -

STATE OF ILLINOIS
DEPARTMENT OF TRANSPORTATION

OVERHEAD SIGN STRUCTURES
MEDIAN SUPPORT FOUNDATION DETAILS

SHEET 7 OF 10 SHEETS

F.A.I. RTE.	SECTION	COUNTY	TOTAL SHEETS	SHEET NO.
64	(97-2) B-5	WHITE	578	176

CONTRACT NO. 78057

ILLINOIS FED. AID PROJECT FAI 64/WABASH RIVER

BAR LIST - EACH FOUNDATION

Bar	Number	Size	Length	Shape
v4(E)	24	#9	F less 5"	—
#4 bar spiral (E) - see Side Elevation				

NOTES:

The foundation dimensions shown are based on the presence of mostly cohesive soils with an average Unconfined Compressive Strength (Qu) of at least 1.25 tsf, which must be determined by previous soil investigations at the jobsite. When other conditions are indicated, the boring data will be included in the plans and the foundation dimensions shown will be the result of site specific designs.

If the conditions encountered are different than those indicated, the Contractor shall notify the Engineer to determine if the foundation dimensions need to be modified. If dimensions "B" or "F" are revised by more than 12" by the Contractor, "as-built" plans shall be prepared and submitted to the District Bureau of Operations for future reference.

No sonotubes or decomposable forms shall be used below the lower conduit entrance. Permanent metal forms or other shielding may not be left in place below that elevation without the Engineer's written permission.

Concrete shall be placed monolithically, without construction joints.

Backfill shall be placed per Article 502 of Standard Specification and prior to erection of support column.

A normal surface finish followed by a Concrete Sealer application will be required on concrete surfaces above the lowest elevation 6" below finished ground line. Cost included in Drilled Shaft Concrete Foundation.

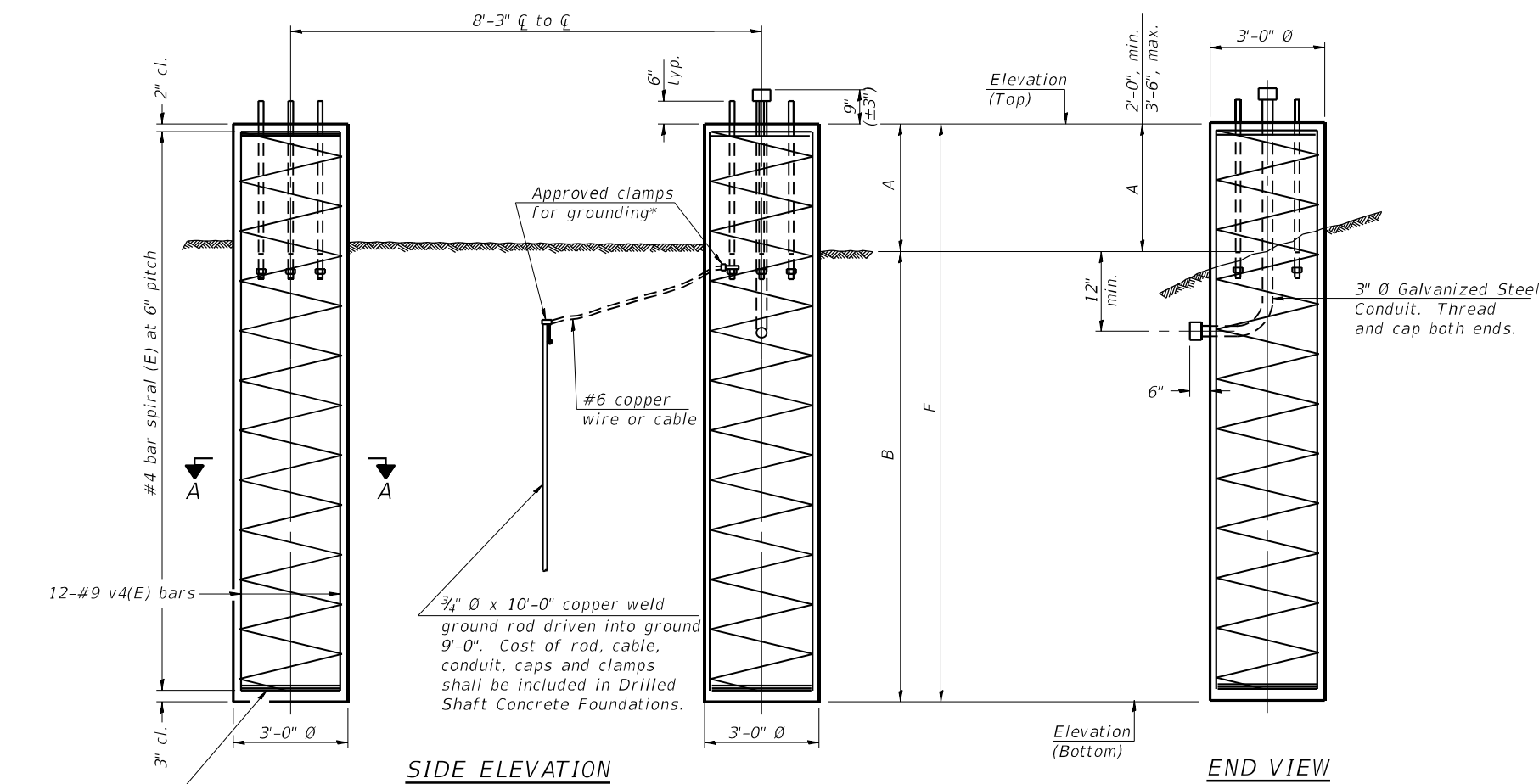

SIDE ELEVATION

END VIEW

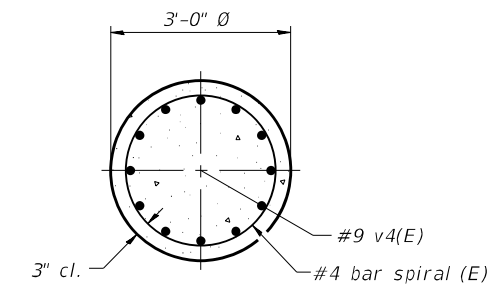

SECTION A-A

3 hoops minimum top and bottom

Approved clamps for grounding*
#6 copper wire or cable
3/4" Ø x 10'-0" copper weld ground rod driven into ground 9'-0". Cost of rod, cable, conduit, caps and clamps shall be included in Drilled Shaft Concrete Foundations.

For anchor rod size and placement, see Support Frame Detail Sheet.

* Anchor rod shall be ground or filed to bright metal at clamp and cable connection location.

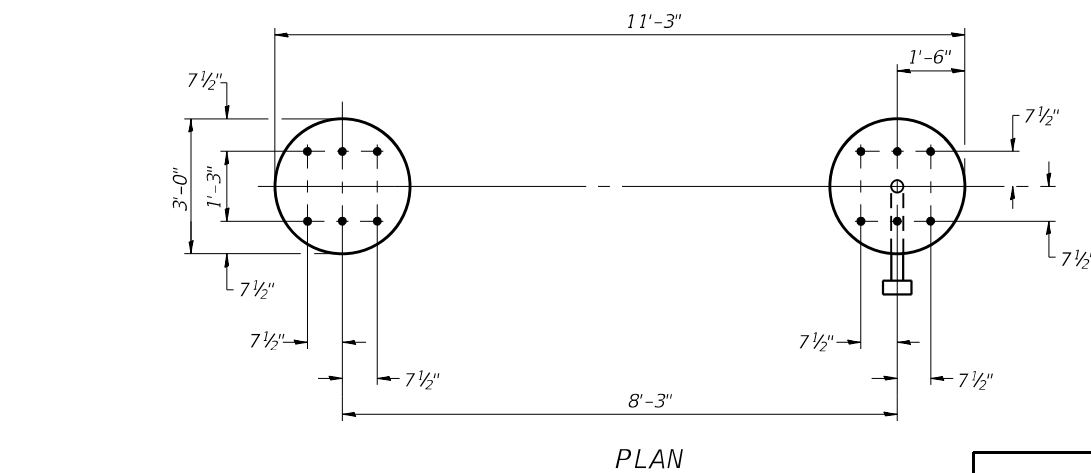

PLAN

DETAILS FOR 10" Ø SUPPORT FRAME TYPE I-A or II-A TRUSS

Structure Number	Station	Left Foundation			Right Foundation			Class DS Concrete (Cu. Yds.)		
		Elevation Top	Elevation Bottom	F	Elevation Top	Elevation Bottom	F			
9S097164L130.5	1872+00				408.16	388.66	2'-0"	17'-6"	19'-6"	10.3

MODEL: Default
FILE NAME: E:\0816\1\Struct\Final Design\CADD\CADD_Sheets\78057-08.dgn

054-F3

2-17-2017

LIN ENGINEERING, LTD.
Consulting Engineers
Springfield, Illinois

USER NAME =	DESIGNED -	REVISED -
PLOT SCALE =	CHECKED -	REVISED -
PLOT DATE = 6/30/2023	DRAWN -	REVISED -
	CHECKED -	REVISED -

**STATE OF ILLINOIS
DEPARTMENT OF TRANSPORTATION**

**OVERHEAD SIGN STRUCTURES
DRILLED SHAFT DETAILS**

SHEET 8 OF 10 SHEETS

F.A.I. RTE.	SECTION	COUNTY	TOTAL SHEETS	SHEET NO.
64	(97-2) B-5	WHITE	578	177
CONTRACT NO. 78057				
ILLINOIS FED. AID PROJECT FAI 64/WABASH RIVER				

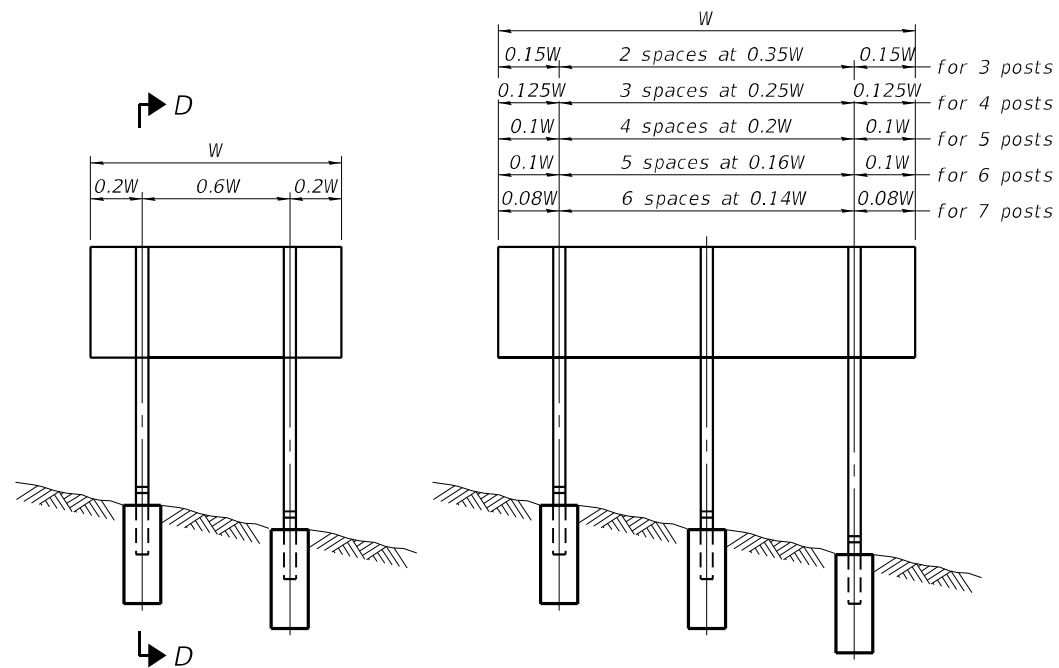

ELEVATION

0.15W	2 spaces at 0.35W	0.15W	for 3 posts
0.125W	3 spaces at 0.25W	0.125W	for 4 posts
0.1W	4 spaces at 0.2W	0.1W	for 5 posts
0.1W	5 spaces at 0.16W	0.1W	for 6 posts
0.08W	6 spaces at 0.14W	0.08W	for 7 posts

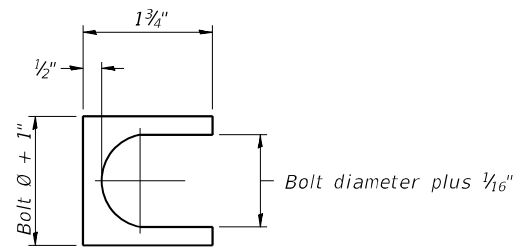

SHIM DETAIL

Furnish two 0.01" thick and two 0.03" thick stainless steel or brass (ASTM B36) shims per post.

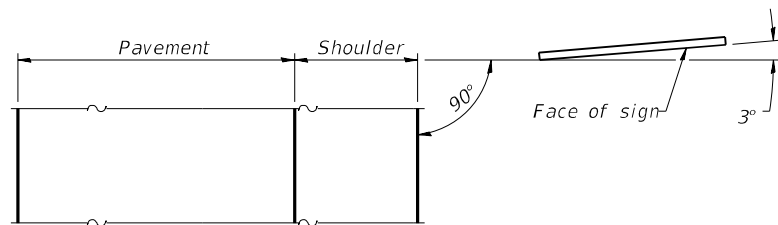

LOCATION SKETCH

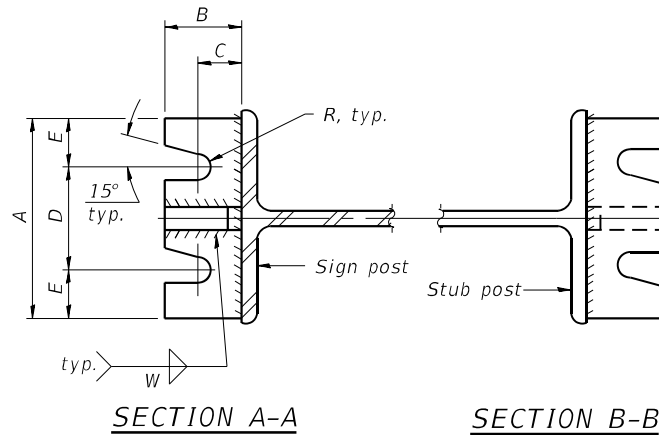

SECTION A-A

SECTION B-B

(See table for dimensions.)

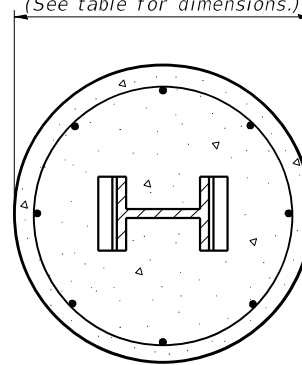

SECTION C-C

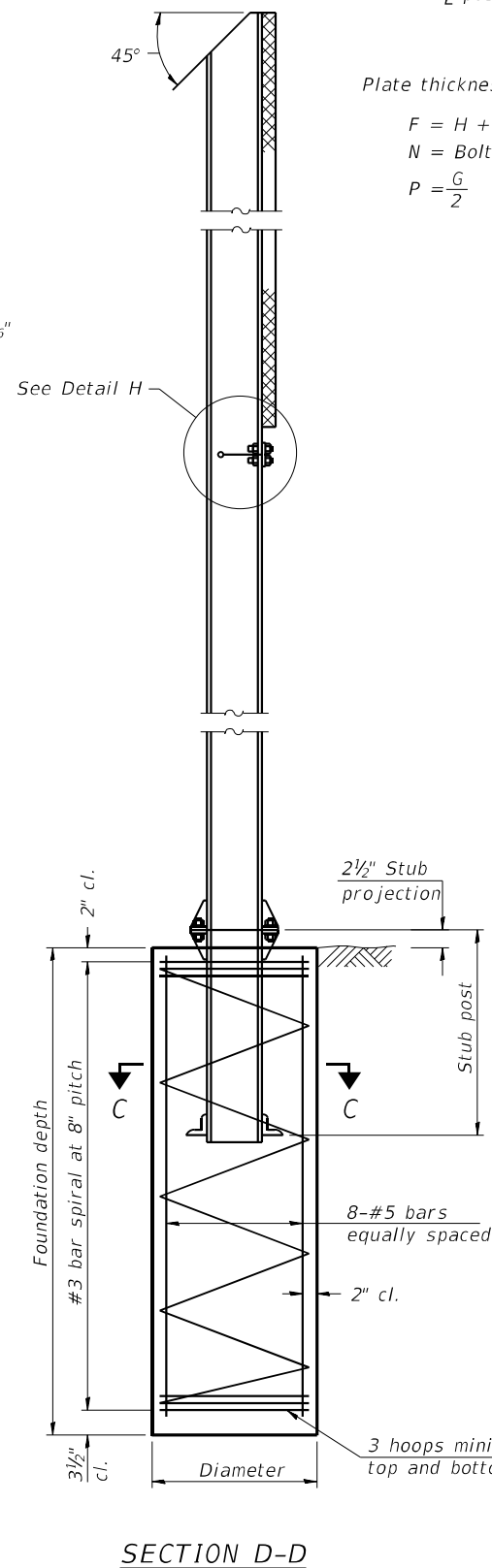

SECTION D-D

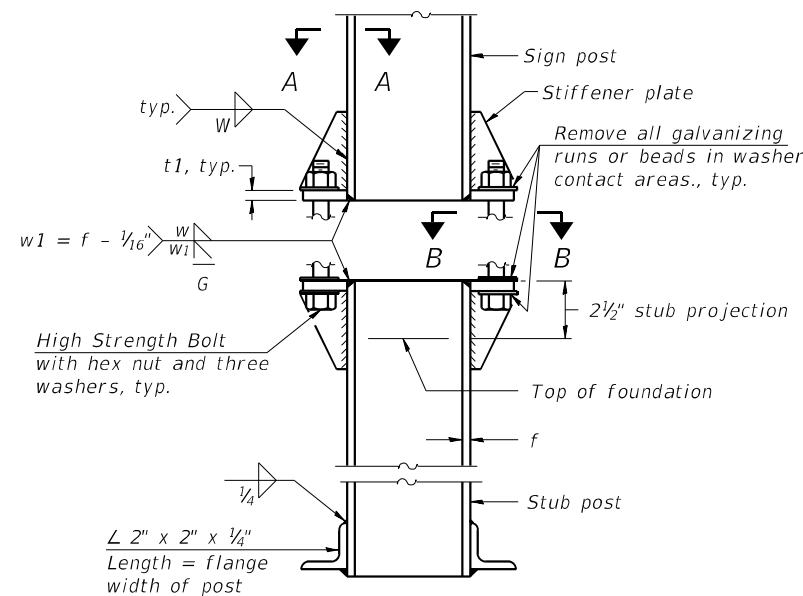

**ELEVATION
SIGN POST & STUB POST**

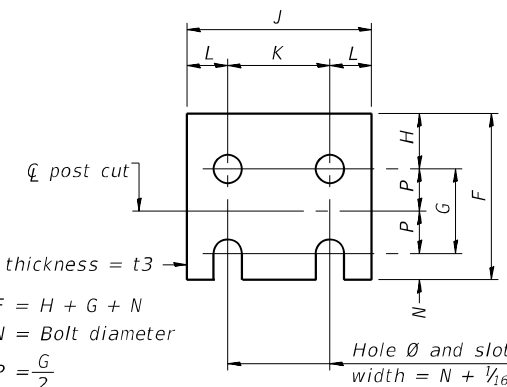

FUSE PLATE DETAIL
(Install with notches down.)

N = Bolt Diameter	G	H
1/2"	2"	1 1/8"
5/8"	2 1/4"	1 1/4"
3/4"	2 1/2"	1 3/8"
7/8"	2 3/4"	1 1/2"
1"	3"	1 5/8"
1 1/8"	3 1/4"	1 3/4"
1 1/4"	3 1/2"	1 7/8"

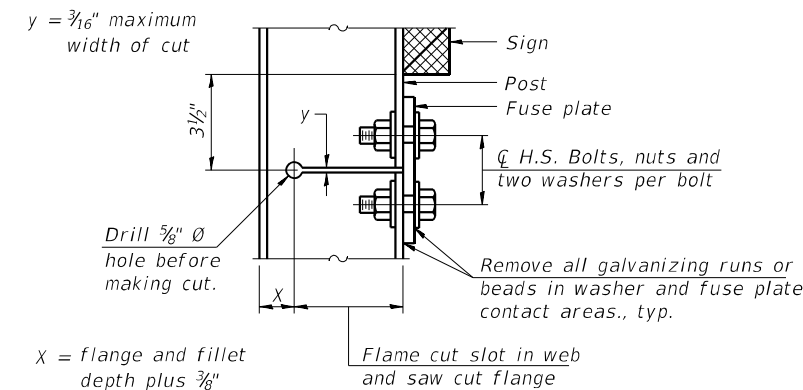

DETAIL H

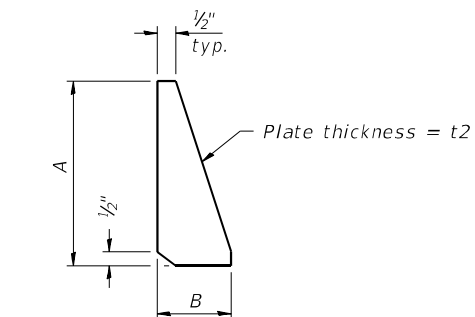

STIFFENER PLATE DETAIL
Diameter

GENERAL NOTES

Posts shall be plumbed by using shims with post-to-stub post connection bolts snug tight only. Final tightening of all High Strength Bolts shall be in accordance with Article 727.05 and threads at the junction of the bolt and nut shall be burred or center punched to prevent the nut from loosening.

LOADING: 80 m.p.h. wind with 30% gust factor, normal to sign.

DESIGN STRESSES:
Structural steel - 20,000 p.s.i.
Reinforcing steel - 20,000 p.s.i.
Concrete - 1,400 p.s.i.
Footing soil pressure - 2,000 p.s.f.

After fabrication, the post, fuse plate and upper 6", min. of the stub post shall be hot-dip galvanized in accordance with AASHTO M111. All bolts, nuts and washers shall be hot-dip galvanized in accordance with AASHTO M232.

Work this sheet with Base Sheet BAW-A-2.

(Sheet 1 of 2)

MODEL: Default
FILE NAME: E:\0816\1\Struct\Final_Design\CADD\CADD_Sheets\78057-09.dgn

BAW-A-1

2-17-2017

LE LIN ENGINEERING, LTD.
Consulting Engineers
Springfield, Illinois

USER NAME =	DESIGNED -	REVISIONS -
PLOT SCALE =	CHECKED -	REVISIONS -
PLOT DATE = 6/30/2023	DRAWN -	REVISIONS -
	CHECKED -	REVISIONS -

STATE OF ILLINOIS
DEPARTMENT OF TRANSPORTATION

BREAK-AWAY WIDE FLANGE
STEEL SIGN POST DETAILS

SHEET 9 OF 10 SHEETS

F.A.I. RTE.	SECTION	COUNTY	TOTAL SHEETS	SHEET NO.
64	(97-2) B-5	WHITE	578	178
CONTRACT NO. 78057				
ILLINOIS FED. AID PROJECT FAI 64/WABASH RIVER				

POST	CONCRETE FOUNDATION TABLE							POST TO STUB POST CONNECTION DATA								FUSE PLATE DATA						
	Foundation			Reinforcement			Stub Post Length	Bolt Size	A	B	C	D	E	t1	t2	R	W	J	K	L	t3	
	Diameter*	Minimum Depth	Concrete ⁽¹⁾ (cu. yds.)	Vertical Bars Length	Bar Spirals Diameter	lbs. ⁽²⁾																
W6x9	2'-0"	6'-0"	0.70	5'-9"	1'-8 1/2"	79'-0"	78	2'-3"	5/8" x 3 1/4"	6"	2 1/4"	1 1/4"	3 1/2"	1 1/4"	3/4"	1 1/2"	1 1/32"	1/4"	4"	2 1/4"	7/8"	1/4"
W6x15	2'-0"	6'-0"	0.70	5'-9"	1'-8 1/2"	79'-0"	78	2'-6"	5/8" x 3 1/4"	6"	2 1/4"	1 1/4"	3 1/2"	1 1/4"	3/4"	1 1/2"	1 1/32"	1/4"	6"	3 1/2"	1 1/4"	3/8"
W8x18	2'-0"	6'-0"	0.70	5'-9"	1'-8 1/2"	79'-0"	78	2'-6"	3/4" x 3 3/4"	6"	2 1/2"	1 3/8"	3 1/4"	1 3/8"	1"	1 1/2"	1 3/32"	5/16"	5 1/4"	2 3/4"	1 1/4"	3/8"
W10x22	2'-6"	6'-6"	1.18	6'-3"	2'-2 1/2"	105'-0"	92	3'-0"	3/4" x 3 3/4"	6"	2 1/2"	1 3/8"	3 1/4"	1 3/8"	1"	1 1/2"	1 3/32"	5/16"	5 3/4"	2 3/4"	1 1/2"	1/2"
W10x26	2'-6"	7'-0"	1.27	6'-9"	2'-2 1/2"	112'-0"	98	3'-0"	7/8" x 4"	7"	2 3/4"	1 1/2"	4"	1 1/2"	1"	3/4"	1 5/32"	3/8"	5 3/4"	2 3/4"	1 1/2"	5/8"
W12x26	2'-6"	7'-9"	1.41	7'-6"	2'-2 1/2"	119'-0"	107	3'-0"	7/8" x 4"	7"	2 3/4"	1 1/2"	4"	1 1/2"	1"	3/4"	1 5/32"	3/8"	6 1/2"	3 1/2"	1 1/2"	5/8"
W14x30	3'-0"	7'-3"	1.90	7'-0"	2'-8 1/2"	145'-0"	113	3'-0"	7/8" x 4"	7"	2 3/4"	1 1/2"	4"	1 1/2"	1"	3/4"	1 5/32"	3/8"	6 3/4"	3 1/2"	1 5/8"	1/2"
W14x38	3'-0"	8'-0"	2.09	7'-9"	2'-8 1/2"	153'-0"	122	3'-6"	1" x 4 1/2"	7 1/2"	3"	1 3/4"	4"	1 3/4"	1 1/4"	3/4"	1 7/32"	3/8"	6 3/4"	3 1/2"	1 5/8"	1/2"
W16x45	3'-0"	8'-6"	2.23	8'-3"	2'-8 1/2"	162'-0"	130	3'-6"	1" x 4 1/2"	7 1/2"	3"	1 3/4"	4"	1 3/4"	1 1/4"	3/4"	1 7/32"	3/8"	7"	3 1/2"	1 3/4"	1/2"

*Dimensional changes required for varying site conditions shall be approved by the Engineer.

POST	FUSE PLATE BOLT SIZE																					
	Sign Height																					
	4'-0"	5'-0"	6'-0"	7'-0"	8'-0"	9'-0"	10'-0"	11'-0"	12'-0"	13'-0"	14'-0"	15'-0"	16'-0"	17'-0"	18'-0"	19'-0"	20'-0"	21'-0"	22'-0"	23'-0"	24'-0"	
W6x9	1/2" x 1 1/2"	1/2" x 1 1/2"	1/2" x 1 1/2"	1/2" x 1 1/2"	—	—	—	—	—	—	—	—	—	—	—	—	—	—	—	—	—	
W6x15	1/2" x 1 3/4"	1/2" x 1 3/4"	1/2" x 1 3/4"	5/8" x 2"	5/8" x 2"	3/4" x 2"	3/4" x 2"	3/4" x 2"	3/4" x 2"	3/4" x 2"	—	—	—	—	—	—	—	—	—	—	—	
W8x18	1/2" x 1 3/4"	1/2" x 1 3/4"	1/2" x 1 3/4"	1/2" x 1 3/4"	5/8" x 2"	5/8" x 2"	3/4" x 2"	3/4" x 2"	3/4" x 2"	3/4" x 2"	—	—	—	—	—	—	—	—	—	—	—	
W10x22	1/2" x 2"	1/2" x 2"	1/2" x 2"	1/2" x 2"	1/2" x 2"	5/8" x 2"	5/8" x 2"	3/4" x 2 1/4"	3/4" x 2 1/4"	3/4" x 2 1/4"	3/4" x 2 1/4"	3/4" x 2 1/4"	3/4" x 2 1/4"	—	—	—	—	—	—	—	—	
W10x26	1/2" x 2"	1/2" x 2"	1/2" x 2"	1/2" x 2"	1/2" x 2"	5/8" x 2 1/4"	5/8" x 2 1/4"	3/4" x 2 1/2"	3/4" x 2 1/2"	3/4" x 2 1/2"	3/4" x 2 1/2"	3/4" x 2 1/2"	3/4" x 2 1/2"	3/4" x 2 1/2"	—	—	—	—	—	—	—	
W12x26	1/2" x 2"	1/2" x 2"	1/2" x 2"	1/2" x 2"	1/2" x 2"	5/8" x 2 1/4"	5/8" x 2 1/4"	3/4" x 2 1/2"	3/4" x 2 1/2"	3/4" x 2 1/2"	3/4" x 2 1/2"	3/4" x 2 1/2"	3/4" x 2 1/2"	3/4" x 2 1/2"	3/4" x 2 1/2"	—	—	—	—	—	—	
W14x30	1/2" x 2"	1/2" x 2"	1/2" x 2"	1/2" x 2"	1/2" x 2"	5/8" x 2"	5/8" x 2"	3/4" x 2 1/4"	3/4" x 2 1/4"	3/4" x 2 1/4"	3/4" x 2 1/4"	3/4" x 2 1/4"	3/4" x 2 1/4"	3/4" x 2 1/4"	3/4" x 2 1/4"	3/4" x 2 1/4"	—	—	—	—	—	
W14x38	1/2" x 2"	1/2" x 2"	1/2" x 2"	1/2" x 2"	1/2" x 2"	5/8" x 2 1/4"	5/8" x 2 1/4"	3/4" x 2 1/2"	3/4" x 2 1/2"	3/4" x 2 1/2"	3/4" x 2 1/2"	3/4" x 2 1/2"	3/4" x 2 1/2"	3/4" x 2 1/2"	3/4" x 2 1/2"	3/4" x 2 1/2"	3/4" x 2 1/4"	3/4" x 2 1/4"	1" x 2 3/4"	1" x 2 3/4"	1" x 2 3/4"	1" x 2 3/4"
W16x45	—	1/2" x 2"	1/2" x 2"	1/2" x 2"	1/2" x 2"	1/2" x 2"	1/2" x 2"	5/8" x 2 1/4"	5/8" x 2 1/4"	5/8" x 2 1/4"	3/4" x 2 1/2"	3/4" x 2 1/2"	3/4" x 2 1/2"	3/4" x 2 1/2"	3/4" x 2 1/2"	3/4" x 2 1/2"	3/4" x 2 1/4"	3/4" x 2 1/4"	1" x 2 3/4"	1" x 2 3/4"	1" x 2 3/4"	1" x 2 3/4"

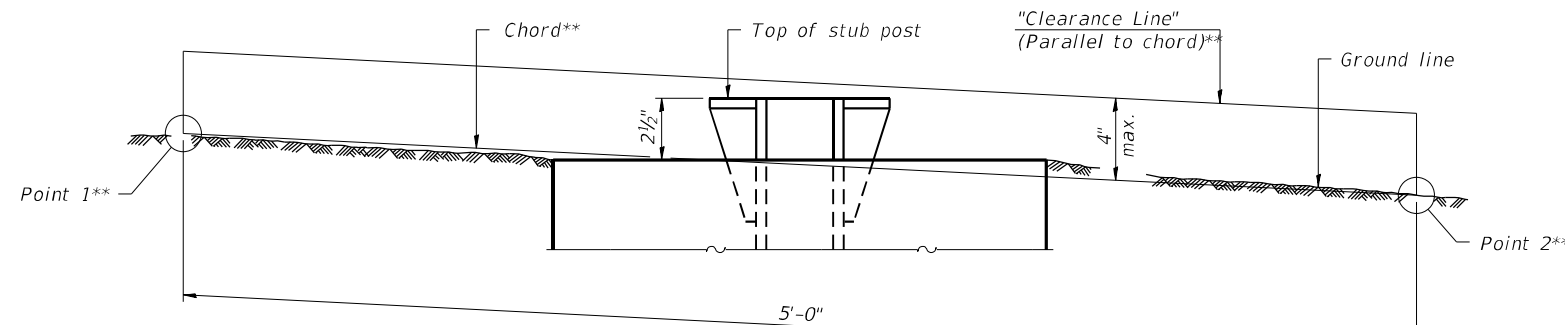

ELEVATION
GROUND LINE & STUB POST

** For all "Point 1" and "Point 2" locations, "Clearance Line" must be at or above top of stub post.

- ① Quantity includes all concrete necessary for one foundation.
- ② Includes reinforcement bars and spiral hooping for one foundation.

MODEL: Default
FILE NAME: E:\0816-1\Struct\Final_Design\CADD\CADD_Sheets\78057-10.dgn

BAW-A-2

2-17-2017

(Sheet 2 of 2)

LE LIN ENGINEERING, LTD.
Consulting Engineers
Springfield, Illinois

USER NAME =	DESIGNED -	REVISED -
PLOT SCALE =	CHECKED -	REVISED -
PLOT DATE = 6/30/2023	DRAWN -	REVISED -
	CHECKED -	REVISED -

STATE OF ILLINOIS
DEPARTMENT OF TRANSPORTATION

BREAK-AWAY WIDE FLANGE
STEEL SIGN POST TABLES

SHEET 10 OF 10 SHEETS

F.A.I. RTE.	SECTION	COUNTY	TOTAL SHEETS	SHEET NO.
64	(97-2) B-5	WHITE	578	179
CONTRACT NO. 78057				
ILLINOIS FED. AID PROJECT FAI 64/WABASH RIVER				

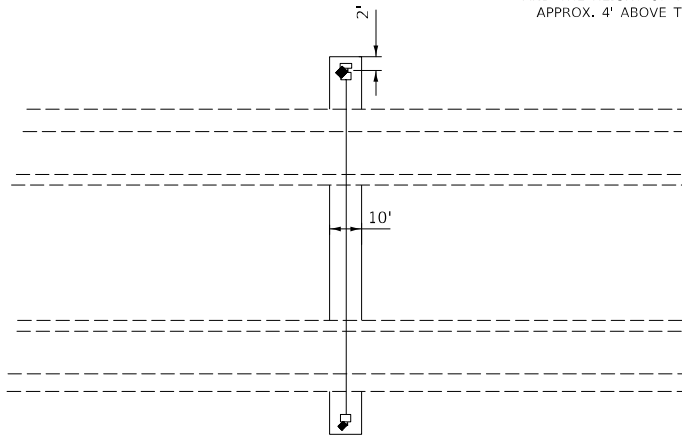
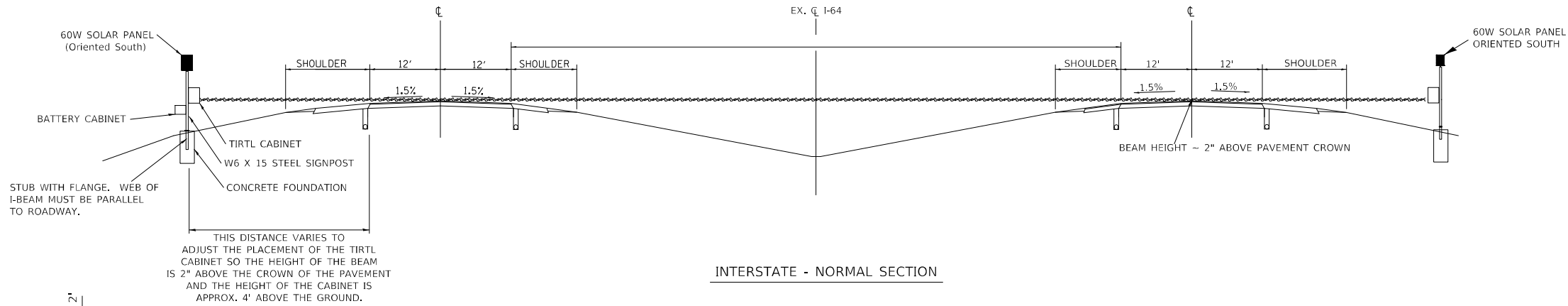

WEED BARRIER - PC CONC SIDEWALK SHALL BE PLACED AS SHOWN 8' TO 10' WIDE AND 4" THICK RUNNING FROM 2' BEHIND POST TO POST.

NOTES:

1. SYSTEM CONSISTS OF TWO W6 X 15 I-BEAM SIGNPOSTS WITH CONCRETE FOUNDATION AND A FLANGE WITH BREAKAWAY BOLTS
2. THE I-BEAMS ARE 12' LONG AND DRILLED AS PER THE I-BEAM DETAIL TO ACCOMMODATE A PIPE TO ALLOW THE MOUNTING OF THE SOLAR PANEL.
3. THE WEB OF THE I-BEAM IS TO BE PLACED PARALLEL TO THE LANES.
4. THE TWO POSTS MUST BE PLACED DIRECTLY ACROSS FROM EACH OTHER AND PERPENDICULAR TO THE LANES.
5. TWO POSTS ARE REQUIRED LOCATED AS PER THE ENGINEER AND DRAWING.
6. THE CABINETS ARE ATTACHED TO THE I-BEAM USING 8" GALVANIZED J-BOLTS.
7. THE BOTTOM OF THE CABINET HEIGHT MUST BE NO LOWER THAN 4' ABOVE THE GROUND AND BE ABLE TO VIEW ACROSS ALL LANES AT THE CROWN OF THE PAVEMENT.
8. THE IDOT OFFICE OF PLANNING AND PROGRAMMING DATA MANAGEMENT LAB RICH MARX (217-782-2065) SHALL BE NOTIFIED TWO WEEKS PRIOR TO THE LAYOUT AND SHALL BE PRESENT DURING THE PLACEMENT OF THE POST FOUNDATIONS.

TIRTL TRAFFIC COUNTER SCHEDULE OF QUANTITIES (FOR INFORMATION ONLY)

CODE NUMBER	ITEM	UNIT	QUANTITY
42400100	PORTLAND CEMENT CONCRETE SIDEWALK 4"	SQ FT	1,125
72700100	STRUCTURAL STEEL SIGN SUPPORT - BREAKAWAY	POUND	520
73400100	CONCRETE FOUNDATIONS	CU YD	1.4
X0320089	TRAFFIC COUNTER - TIRTL SYSTEM (INCLUDES BELOW)	EACH	1
TIRTL TRAFFIC DATA COLLECTION SYSTEM INCLUDES:			
	Sierra Wireless Modem RV-50	EACH	1
	Panorama Low Profile LTE MiMo LGAM-BC3G-26-35P Antenna	EACH	1
	TIRTL CABINET 15" X 27" X 16"	EACH	2
	BATTERY CABINET 16.5" X 16" X 11.5" BBA1M w/ #2 Police Lock	EACH	1
	SOLAR PANEL 60 W 12 VDC with Bracket and junction box	EACH	2
	TIRTL TRAFFIC COUNTER	EACH	1
	SUNSAVER SOLAR CHARGE REGULATOR 10 AMP 12 VDC	EACH	2
	BATTERY - 33 AH ABSORBED ELECTROLYTE 8" X 5.5" X 7" (DEEP CYCLE)	EACH	1
	BATTERY -104AH ABSORBED ELECTROLYTE 10" X 6" X 8" (DEEP CYCLE)	EACH	1

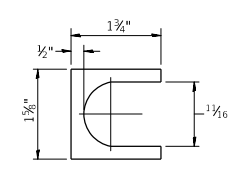
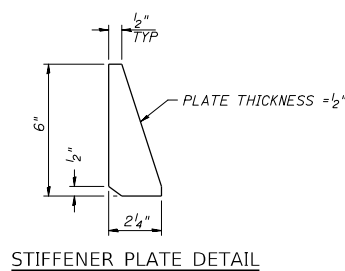
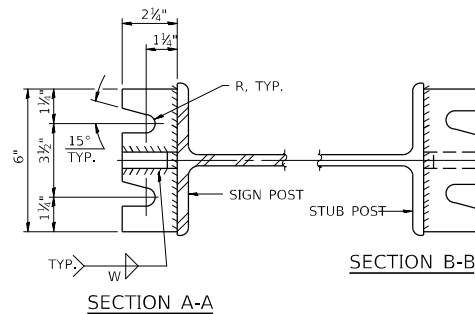
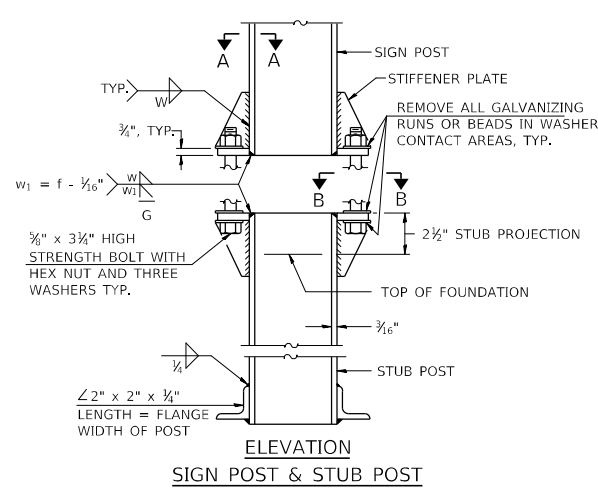
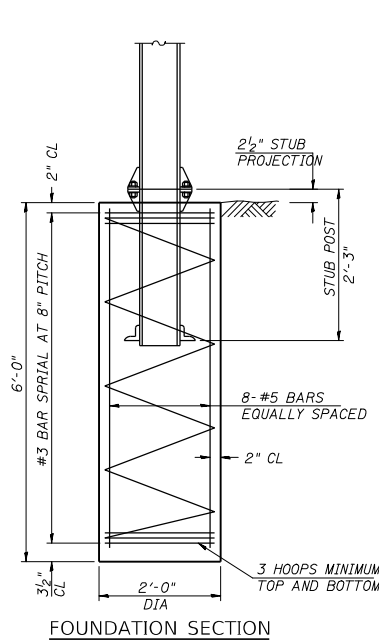

SHIM DETAIL
FURNISH TWO 0.01" THICK AND TWO 0.03" THICK STAINLESS STEEL OR BRASS (ASTM B36) SHIMS PER POST.

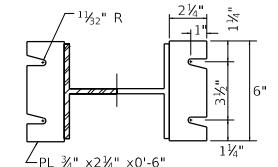
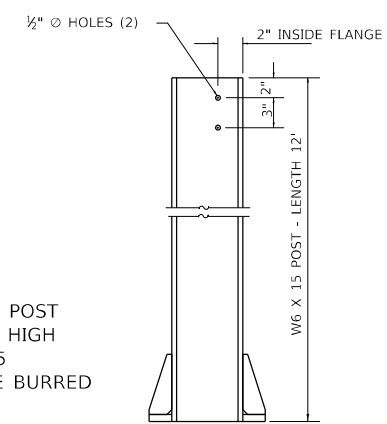

GENERAL NOTES

POSTS SHALL BE PLUMBED BY USING SHIMS WITH POST-TO-STUB POST CONNECTION BOLTS SNUG TIGHT ONLY. FINAL TIGHTENING OF ALL HIGH STRENGTH BOLTS SHALL BE IN ACCORDANCE WITH ARTICLE 727.05 AND THREADS AT THE JUNCTION OF THE BOLT AND NUT SHALL BE BURRED OR CENTER PUNCHED TO PREVENT THE NUT FROM LOOSENING.

LOADING: 80 MPH WIND WITH 30% GUST FACTOR, NORMAL TO SIGN.

DESIGN STRESSES:
STRUCTURAL STEEL - 20,000 PSI
REINFORCING STEEL - 20,000 PSI
CONCRETE - 1,400 PSI
FOOTING SOIL PRESSURE - 2,000 PSF

AFTER FABRICATION, THE POST AND UPPER 6", MIN. OF THE STUB POST SHALL BE HOT-DIP GALVANIZED IN ACCORDANCE WITH AASHTO M111. ALL BOLTS, NUTS AND WASHERS SHALL BE HOT-DIP GALVANIZED IN ACCORDANCE WITH AASHTO M232.

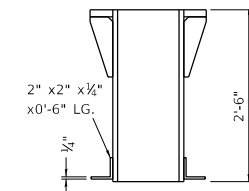

BREAK-AWAY WIDE FLANGE STEEL POST DETAILS

MODEL: 440081.NAMES
FILE NAME: C:\7660\CAD\Sheet\Tirt System\0978959-sh-tirtl_detailB.dgn

KNIGHT
Engineers & Architects

USER NAME = USJM706109	DESIGNED - JS	REVISED -
PLOT SCALE = 1:49,9983	DRAWN - RTA	REVISED -
PLOT DATE = 8/10/2023	CHECKED - JCM	REVISED -
	DATE - 08/11/2023	REVISED -

STATE OF ILLINOIS
DEPARTMENT OF TRANSPORTATION

TRAFFIC COUNTER - TIRTL SYSTEM

SCALE: NONE SHEET OF SHEETS STA. TO STA.

F.A.I. RTE.	SECTION	COUNTY	TOTAL SHEETS	SHEET NO.
64	(97-2) B-5	WHITE	578	180
CONTRACT NO. 78057				
ILLINOIS FED. AID PROJECT FAI 64/WABASH RIVER				

LEGEND

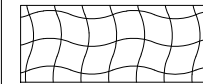

SEEDING, CLASS 2A AND
EROSION CONTROL BLANKET

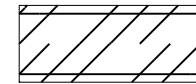

SEEDING, CLASS 3A AND
EROSION CONTROL BLANKET

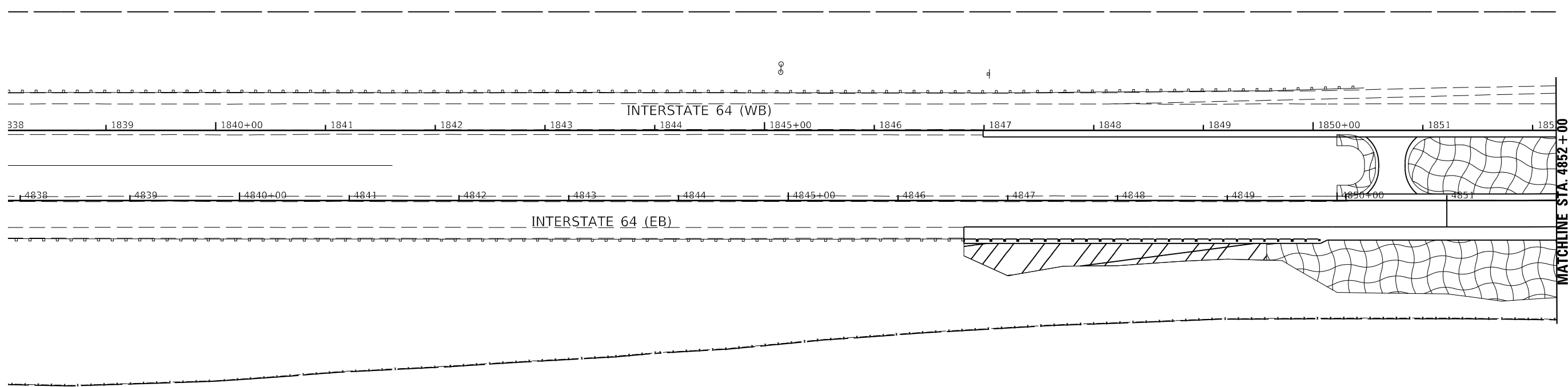

MODEL: I:\MODELS\NAME\ FILE: NAME: L:\2023\CAD\Projects\Landscape\0978057-IL\landscape01.dgn



USER NAME = USRA706046	DESIGNED - JS	REVISED - 11/15/2023
PLOT SCALE = 1:100	DRAWN - RTA	REVISED -
PLOT DATE = 11/10/2023	CHECKED - JCM	REVISED -
	DATE - 08/11/2023	REVISED -

**STATE OF ILLINOIS
DEPARTMENT OF TRANSPORTATION**

**LANDSCAPE PLANS
INTERSTATE 64**

SCALE: SHEET L-1 OF 4 SHEETS STA. TO STA.

F.A.I. RTE.	SECTION	COUNTY	TOTAL SHEETS	SHEET NO.
64	(97-2) B-5	WHITE	578	181
CONTRACT NO. 78057				
ILLINOIS FED. AID PROJECT FAI 64/WABASH RIVER				

LEGEND

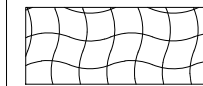

SEEDING, CLASS 2A AND EROSION CONTROL BLANKET

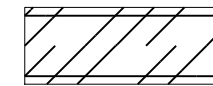

SEEDING, CLASS 3A AND EROSION CONTROL BLANKET

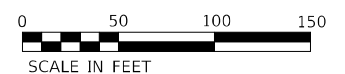
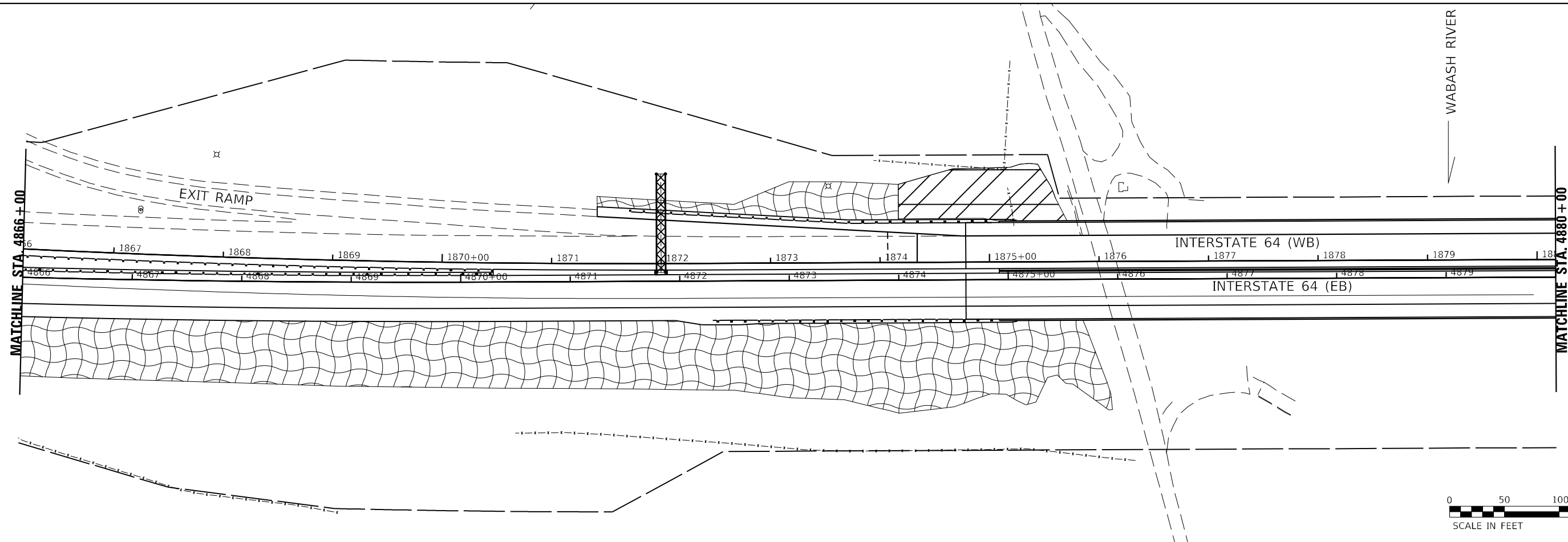
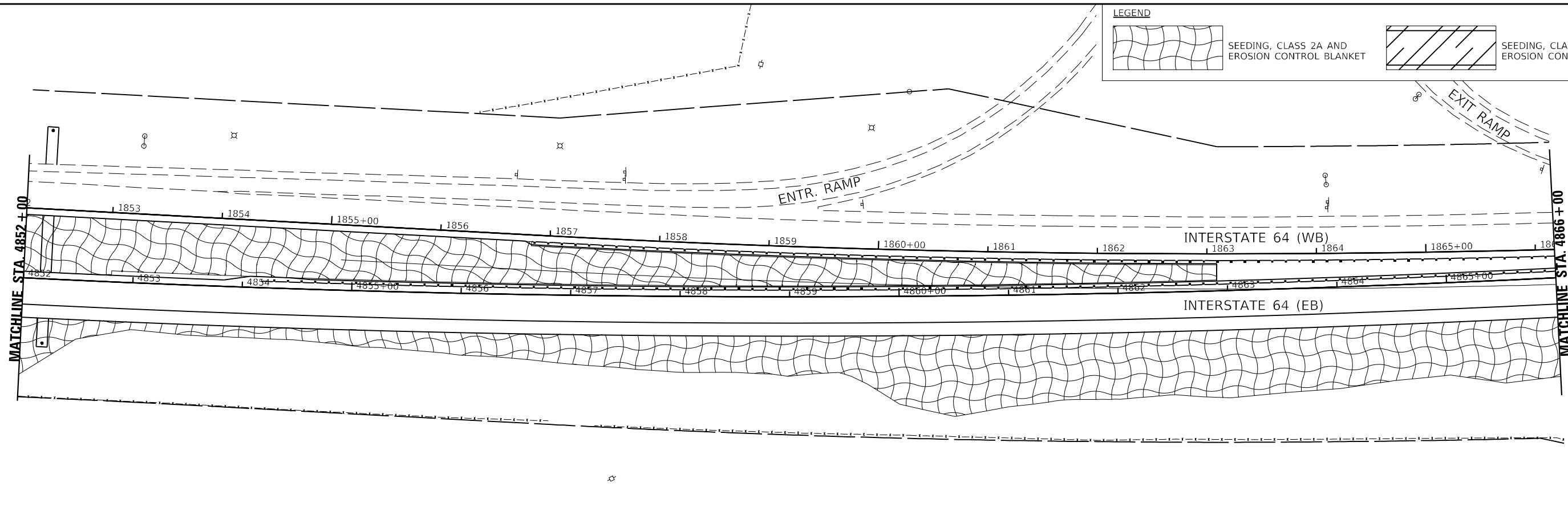

MODEL: I:\MODEL\NAME: FILE: NAME: I:\2023\CAD\Projects\Landscapes\0978507-rh-landscapes-02.dgn

KNIGHT
Engineers & Architects

USER NAME = USRA706046	DESIGNED - JS	REVISED - 11/15/2023
PLOT SCALE = 1:100	DRAWN - RTA	REVISED -
PLOT DATE = 11/10/2023	CHECKED - JCM	REVISED -
	DATE - 08/11/2023	REVISED -

**STATE OF ILLINOIS
DEPARTMENT OF TRANSPORTATION**

**LANDSCAPE PLANS
INTERSTATE 64**

SCALE: SHEET L-2 OF 4 SHEETS STA. TO STA.

F.A.I. RTE.	SECTION	COUNTY	TOTAL SHEETS	SHEET NO.
64	(97-2) B-5	WHITE	578	182
CONTRACT NO. 78057				
ILLINOIS FED. AID PROJECT FAI 64/WABASH RIVER				

LEGEND

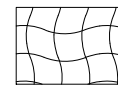

SEEDING, CLASS 2A AND EROSION CONTROL BLANKET

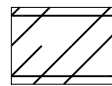

SEEDING, CLASS 3A AND EROSION CONTROL BLANKET

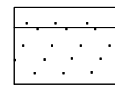

SEEDING, CLASS 4B AND EROSION CONTROL BLANKET

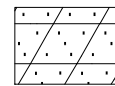

SEEDING, CLASS 4B AND CLASS 5A

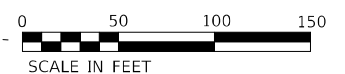
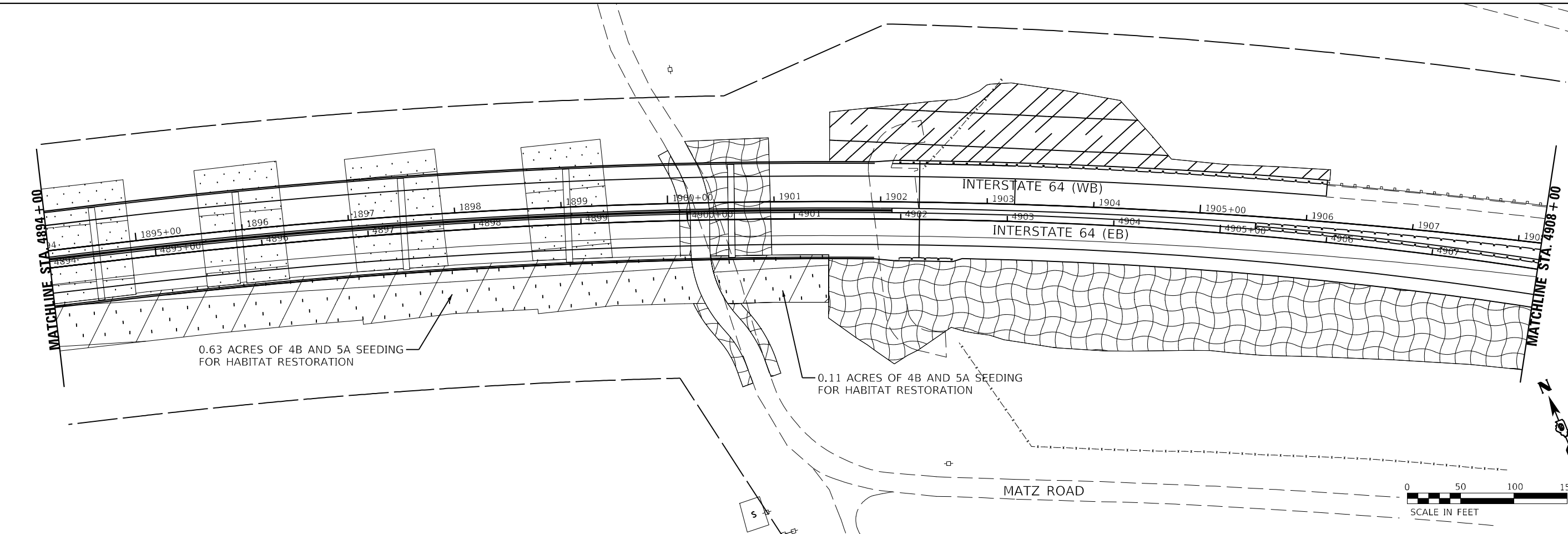
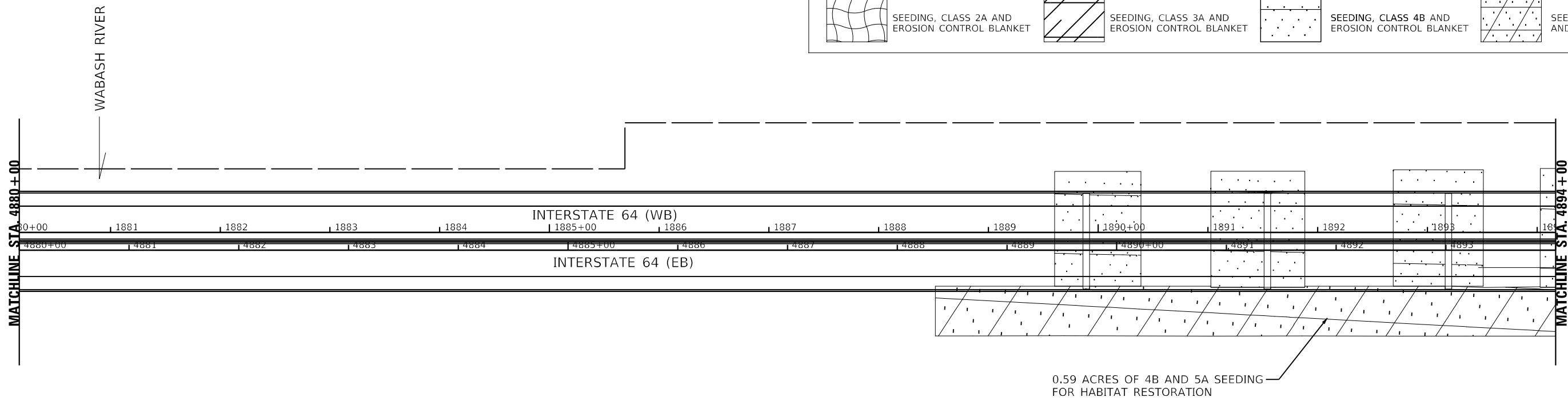

MODEL: \\MODELS\NAMEK
 FILE: \\NAMEK_12160\CAD\Projects\Landscape\097807-rt-hlanfac3a-03.dgn

KNIGHT Engineers & Architects	USER NAME = USRA706046	DESIGNED - JS	REVISED - 11/15/2023
	PLOT SCALE = 1:100	DRAWN - RTA	REVISED -
	PLOT DATE = 11/10/2023	CHECKED - JCM	REVISED -
		DATE - 08/11/2023	REVISED -

**STATE OF ILLINOIS
DEPARTMENT OF TRANSPORTATION**

LANDSCAPE PLANS INTERSTATE 64			
SCALE:	SHEET L-3	OF 4 SHEETS	STA. TO STA.

F.A.I. RTE.	SECTION	COUNTY	TOTAL SHEETS	SHEET NO.
64	(97-2) B-5	WHITE	578	183
CONTRACT NO. 78057				
ILLINOIS FED. AID PROJECT FAI 64/WABASH RIVER				

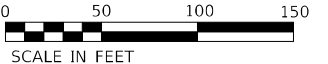
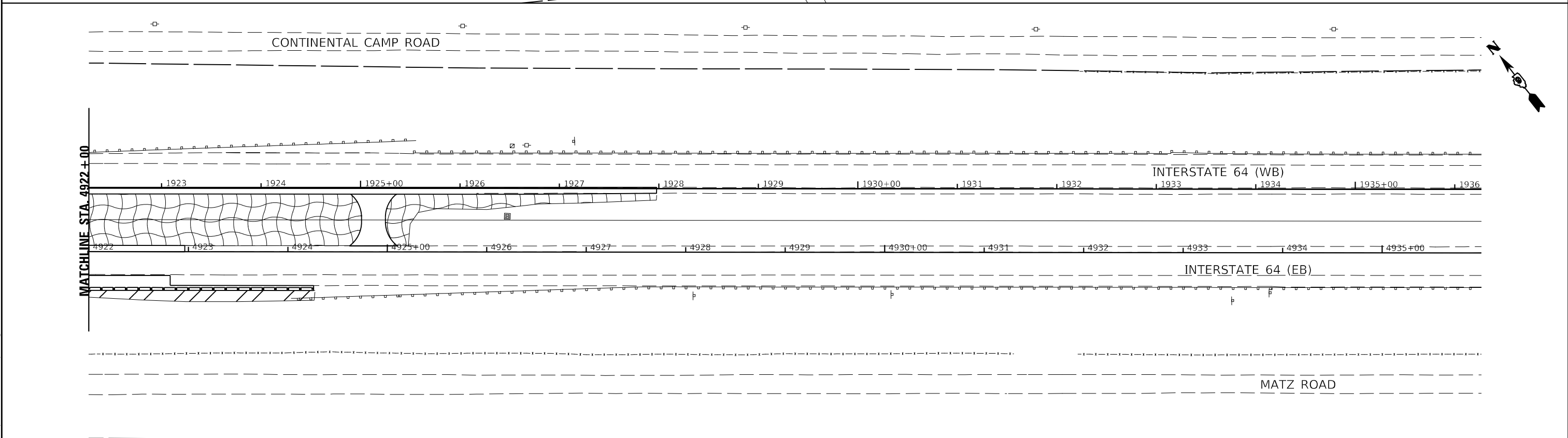
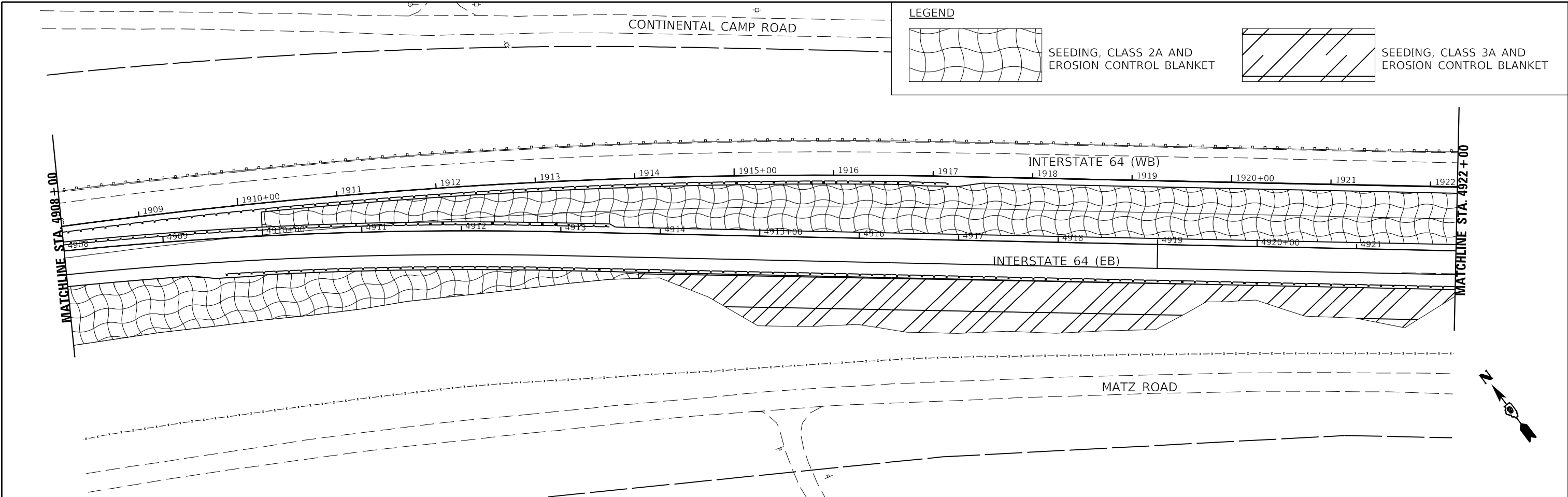

MODEL: \\MODEL\NAME
 FILE: \\MODEL\112660\CAD\Site\Interstate\Landscaping\0978507-rh-landscap-04.dgn

KNIGHT
Engineers & Architects

USER NAME = USRA706046	DESIGNED - JS	REVISED - 11/15/2023
PLOT SCALE = 1:100	DRAWN - RTA	REVISED -
PLOT DATE = 11/10/2023	CHECKED - JCM	REVISED -
	DATE - 08/11/2023	REVISED -

**STATE OF ILLINOIS
DEPARTMENT OF TRANSPORTATION**

**LANDSCAPE PLANS
INTERSTATE 64**

SCALE: SHEET L-4 OF 4 SHEETS STA. TO STA.

F.A.I. RTE.	SECTION	COUNTY	TOTAL SHEETS	SHEET NO.
64	(97-2) B-5	WHITE	578	184
CONTRACT NO. 78057				
ILLINOIS FED. AID PROJECT FAI 64/WABASH RIVER				

Bench Mark: BM #101 chiseled square on SW wingwall of structure #097-0003, station 5875+05, 9.0 feet from edge of bit. pavement for I-64 EBL (Illinois). Elev. 411.35

BM #152 chiseled square on SE bridge abutment of the Wabash River Bridge (SN 097-0003) on the south side of EBL I-64 east side of the Wabash River, station 5902+40, 9.0 feet right from the edge of bit. pavement of EBL I-64 (Indiana). Elev. 403.14

Existing Structure: SN 097-0003 (EBL) and SN 097-0004 (WBL) are dual parallel structures over the Wabash River built in 1967 under Section 97-3B and each consisting of 28 spans with total length of 2705'-3" back to back of abutments. Span lengths from west to east are 1 at 120', 6 at 160', 1 at 120', 1 at 67', 2 at 83', 2 at 67', 2 at 83', 2 at 67', 2 at 83', 2 at 67', 2 at 83', 2 at 67', 2 at 83' and 1 at 67'. The main spans consist of two 4-span continuous 600' units, and the approach spans are five 4-span 300' long units. The main spans 1 through 8 consist of a steel two-girder system with a 12" structural concrete deck supported on the main girder top flange. The main girders are spaced at 20' centers with 8' overhangs on each side. Each superstructure provides 30' clear roadway width between the 2' wide safety walks on each side. The bridge rail is aluminum tubular type mounted on 1' wide concrete parapet. The bridges are 36 ft. out to out of deck. The substructure consists of stub abutments and frame or hammerhead piers supported on piles.

Traffic Control Construction of the proposed EB and WB structures will be done by utilizing median crossovers onto the existing EB roadway.

No Salvage

CURVE DATA

EB I-64	WB I-64
PROP. CURVE I64PR_E_6	PROP. CURVE I64PR_W_6
PI STA. 4898+86.30	PI STA. 1906+14.06
$\Delta = 8^\circ 20' 08"$ (RT)	$\Delta = 22^\circ 11' 00"$ (RT)
$D = 0^\circ 59' 50"$	$D = 0^\circ 59' 40"$
$R = 5,745.75'$	$R = 5,761.92'$
$T = 418.70'$	$T = 1,129.57'$
$L = 835.91'$	$L = 2,230.85'$
$E = 15.24'$	$E = 109.68'$
$SE = 3.4\%$	$SE = 3.4\%$
$TR = 67.00'$	$TR = 67.00'$
$SE RUN = 153.00'$	$SE RUN = 153.00'$
PC STA. 4894+67.60	PC STA. 1894+84.49
PT STA. 4903+03.52	PT STA. 1917+15.34

S.E. Transitions

Transition from normal crown to superelevation
 Sta 1892+95 (WB), Sta 4892+78 (EB)
 Full superelevation at Sta 1895+15 (WB), Sta 4894+98 (EB)
 End superelevation at Sta 1916+85 (WB), Sta 4902+60 (EB)

DESIGN SPECIFICATIONS

2020 AASHTO LRFD Bridge Design Specifications, Customary U.S. Units, 9th Edition

LOADING HL-93

Allow 50#/sq. ft. for future wearing surface.

DESIGN STRESSES

FIELD UNITS

$f'_c = 3,500$ psi (substructure)
 $f'_c = 7,000$ psi (drilled shafts - Pier 1 to 8)
 $f'_c = 4,000$ psi (superstructure)
 $f_y = 60,000$ psi (reinforcement)
 $f_y = 80,000$ psi (drilled shafts - Pier 1 to 8)
 $F_y = 50,000$ psi (AASHTO M270 Gr. 50W)

SEISMIC DATA

Seismic Performance Zone (SPZ) = 2
 Design Spectral Acceleration at 1.0 sec. (SD1) = 0.276g
 Design Spectral Acceleration at 0.2 sec. (SDS) = 0.657g
 Soil Site Class = D
 Operational Category - Critical

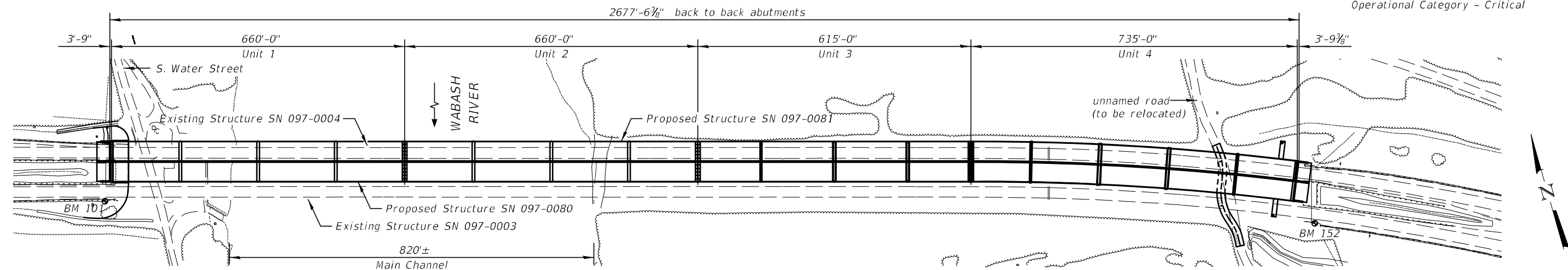

KEY PLAN

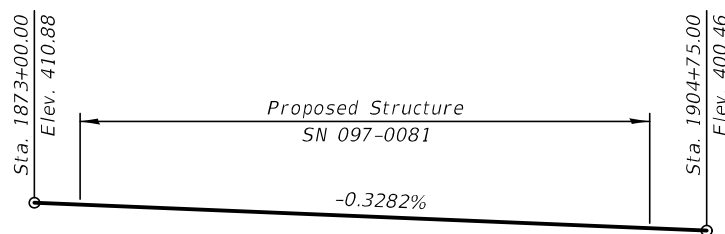

WESTBOUND I-64 - PROPOSED PROFILE GRADE LINE

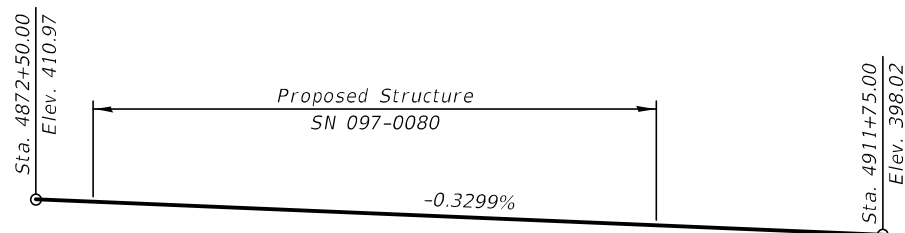

EASTBOUND I-64 - PROPOSED PROFILE GRADE LINE

Note:
 Up to 1/4 inch to be ground off the bridge deck and the bridge approach slabs. The Profile Grade shows the final grade after grinding.

APPROVED
 For Structural Adequacy Only
 Lori A. Sommer
 Engineer of Bridges & Structures

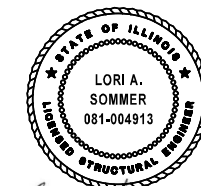

Lori Sommer 8/11/2023
 Lori A. Sommer, P.E., S.E.
 State of Illinois Lic. No. 081-004913
 License Expires: 11/30/2024
 This stamp applies to Drawings S-01 to S-232

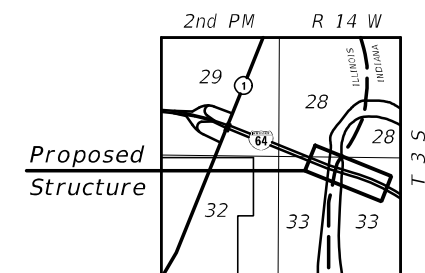

LOCATION SKETCH

KEY PLAN
I-64 OVER WABASH RIVER
PUBLIC WATER
F.A.I. RTE. 64 (I-64) SEC. (97-2)B-5
WHITE (IL) & POSEY (IN) COUNTIES
STATION 4888+41.96 (EB) / 1888+59.80 (WB)
SN 097-0080 (EB) SN 097-0081 (WB)

PLOT DATE = 8/9/2023
 FILE NAME = I:\7660\cadd\Structs\Bridges\7660-510380-GN01.dgn

KNIGHT Engineers & Architects	DESIGNED - KA	REVISION	STATE OF ILLINOIS DEPARTMENT OF TRANSPORTATION	KEY PLAN STRUCTURE NUMBER 097-0080 (EB) AND 097-0081 (WB) SHEET S-01 OF 232 SHEETS	F.A.I. RTE.	SECTION	COUNTY	TOTAL SHEETS	SHEET NO.
	CHECKED - LS	REVISION			64	(97-2) B-5	WHITE	578	185
	SCALE - NONE	REVISION			CONTRACT NO. 78057				
DATE - 8/11/2023	CHECKED - LS	REVISION	PUBLIC WATERS ILLINOIS FED. AID PROJECT						

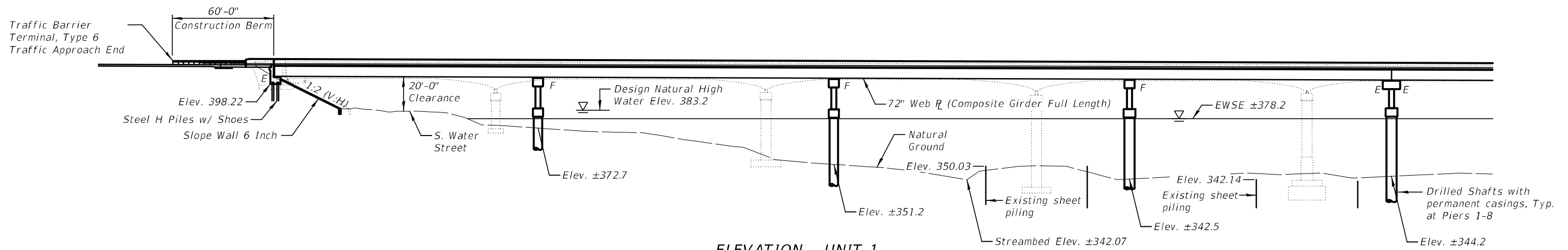

ELEVATION - UNIT 1
* (V:H) @ Rt. L's

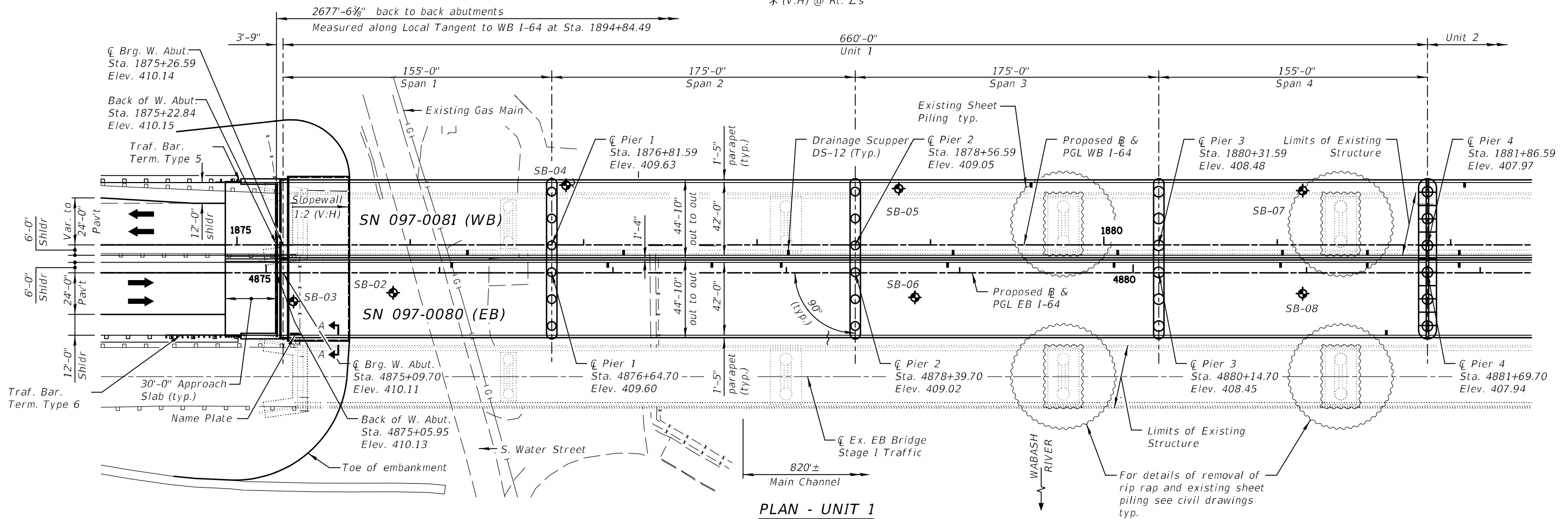

PLAN - UNIT 1

WB SCUPPER LOCATIONS

Station	Offset (ft)
1876+33	6.0
1877+23	6.0
1878+18	6.0
1879+13	6.0
1880+08	6.0
1881+03	6.0
1881+52	6.0
1879+58	-36.0

EB SCUPPER LOCATIONS

Station	Offset (ft)
4876+07	-6.0
4876+97	-6.0
4877+57	-6.0
4877+97	-6.0
4878+93	-6.0
4879+89	-6.0
4880+85	-6.0
4881+35	-6.0
4881+46	36.0

Notes:

Up to 1/4" may be ground off the bridge deck and approach slabs.
Drains shall be located clear of all diaphragms.

Legend

◆ Soil Borings

Note:

For Section A-A see sheet S-08.

PLOT DATE = 8/9/2023
 FILE NAME = I:\7660\cadd\Sheets\Bridges\7660-50080-01-02.dgn

KNIGHT
Engineers & Architects

DESIGNED - KA	REVISION
CHECKED - LS	REVISION
SCALE - NONE	REVISION
DATE - 8/11/2023	REVISION

DESIGNED - KA	REVISION
CHECKED - LS	REVISION
DRAWN - KA	REVISION
CHECKED - LS	REVISION

STATE OF ILLINOIS
DEPARTMENT OF TRANSPORTATION

GENERAL PLAN AND ELEVATION - UNIT 1
STRUCTURE NUMBER 097-0080 (EB) AND 097-0081 (WB)

SHEET S-02 OF 232 SHEETS

F.A.I. RTE.	SECTION	COUNTY	TOTAL SHEETS	SHEET NO.
64	(97-2) B-5	WHITE	578	186
CONTRACT NO. 78057				
PUBLIC WATERS		ILLINOIS FED. AID PROJECT		

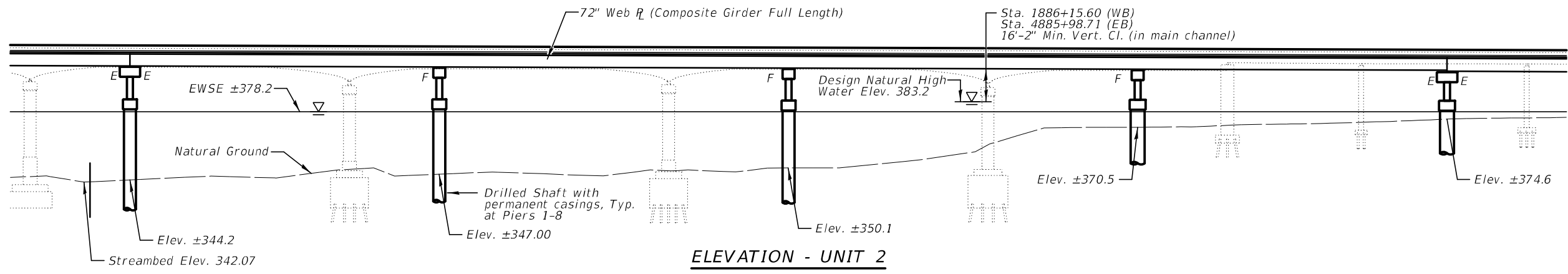

ELEVATION - UNIT 2

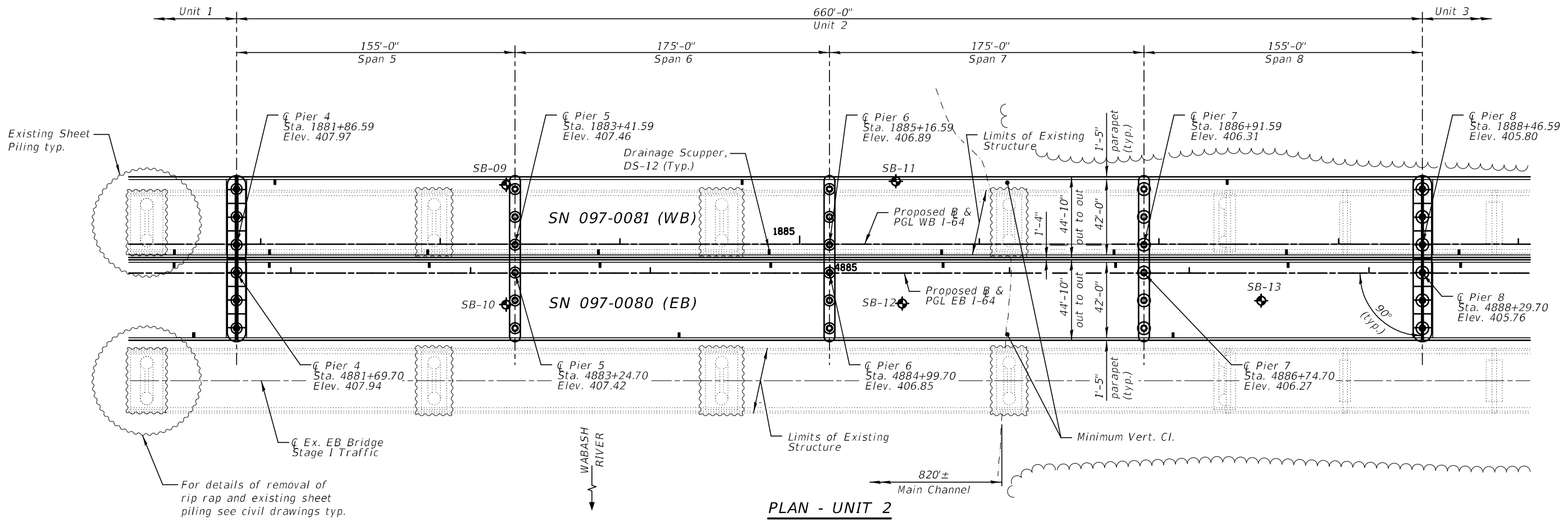

PLAN - UNIT 2

WB SCUPPER LOCATIONS

Station	Offset (ft)
1882+05	6.0
1882+93	6.0
1883+88	6.0
1884+83	6.0
1885+79	6.0
1886+75	6.0
1887+71	6.0
1882+08	-36.0
1884+68	-36.0
1887+38	-36.0

EB SCUPPER LOCATIONS

Station	Offset (ft)
4881+88	-6.0
4882+77	-6.0
4883+72	-6.0
4884+67	-6.0
4885+63	-6.0
4886+59	-6.0
4887+55	-6.0
4884+16	36.0
4886+91	36.0

Notes:
 Up to 1/4" may be ground off the bridge deck and approach slabs.
 Drains shall be located clear of all diaphragms.

Legend
 ◆ Soil Borings

PLOT DATE = 8/9/2023
 FILE NAME = I:\7660\civ\Sheets\Bridges\7660-50080-CM03.dgn

KNIGHT
 Engineers & Architects

DESIGNED - KA	REVISION
CHECKED - LS	REVISION
SCALE - NONE	REVISION
DATE - 8/11/2023	REVISION
DRAWN - KA	
CHECKED - LS	

STATE OF ILLINOIS
DEPARTMENT OF TRANSPORTATION

GENERAL PLAN AND ELEVATION - UNIT 2
STRUCTURE NUMBER 097-0080 (EB) AND 097-0081 (WB)

SHEET S-03 OF 232 SHEETS

F.A.I. RTE.	SECTION	COUNTY	TOTAL SHEETS	SHEET NO.
64	(97-2) B-5	WHITE	578	187
CONTRACT NO. 78057				
PUBLIC WATERS		ILLINOIS FED. AID PROJECT		

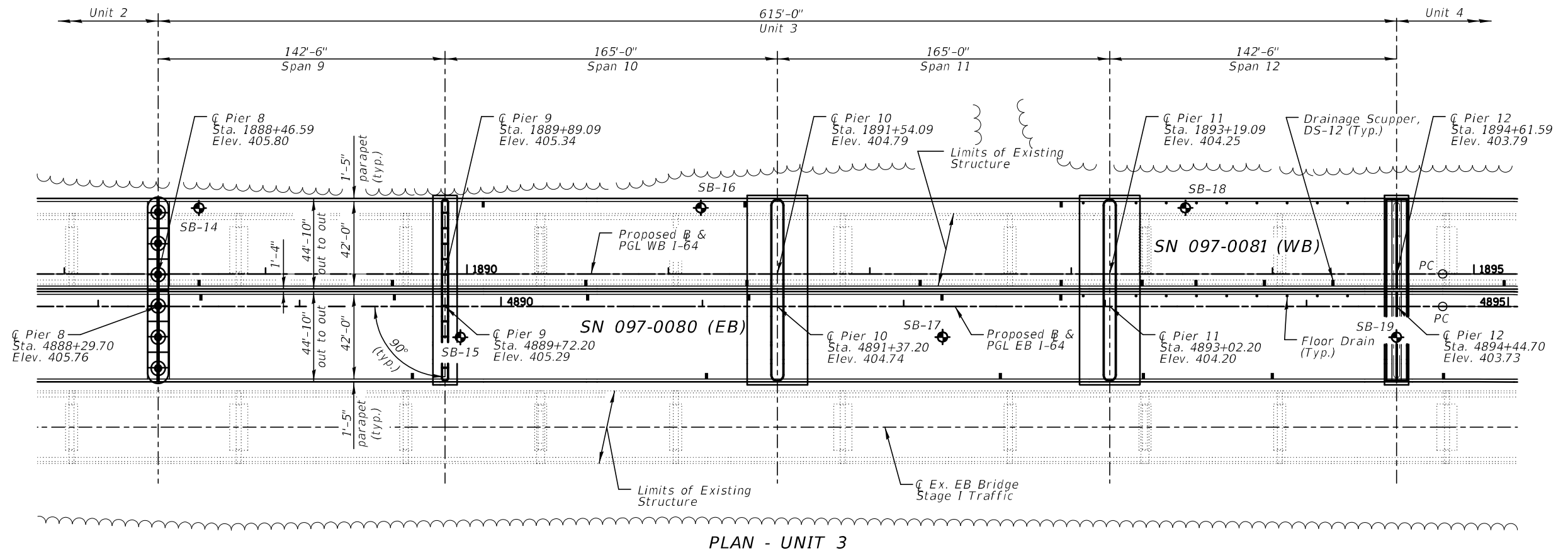
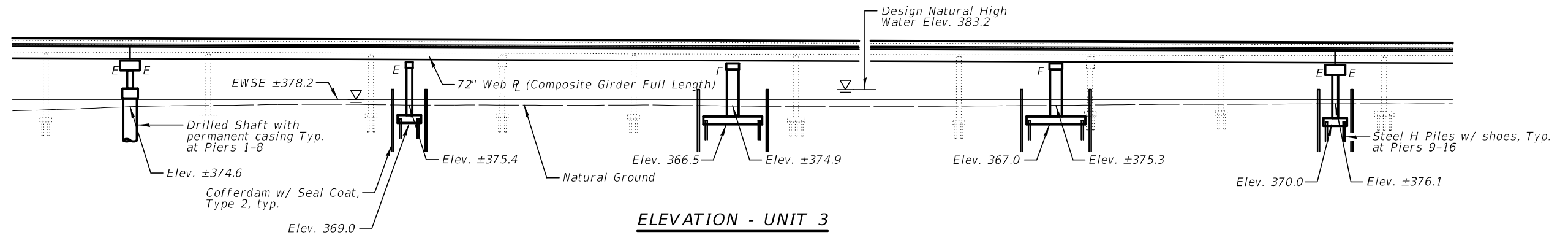

WB SCUPPER LOCATIONS

Station	Offset (ft)
1888+67	6.0
1889+63	6.0
1890+59	6.0
1891+39	6.0
1892+25	6.0
1892+95	6.0
1893+35	6.0
1893+62	6.0
1893+96	6.0
1894+30	6.0
1890+08	-36.0
1891+38	-36.0
1892+95	-36.0

EB SCUPPER LOCATIONS

Station	Offset (ft)
4888+51	-6.0
4889+47	-6.0
4890+43	-6.0
4891+23	-6.0
4892+19	-6.0
4892+78	-6.0
4889+56	36.0
4891+02	36.0
4892+48	36.0
4893+19	36.0
4893+83	36.0

Notes:

Up to 1/4" may be ground off the bridge deck and approach slabs.

For locations of floor drains see sheet S-73.

Drains shall be located clear of all diaphragms.

Legend

◆ Soil Borings

PLOT DATE = 8/9/2023
FILE NAME = I:\7600\cadd\Sheets\Bridges\7600-50080-CM04.dgn

KNIGHT
Engineers & Architects

DESIGNED - KA	REVISION
CHECKED - LS	REVISION
SCALE - NONE	REVISION
DATE - 8/11/2023	REVISION

**STATE OF ILLINOIS
DEPARTMENT OF TRANSPORTATION**

**GENERAL PLAN AND ELEVATION - UNIT 3
STRUCTURE NUMBER 097-0080 (EB) AND 097-0081 (WB)**

SHEET S-04 OF 232 SHEETS

F.A.I. RTE.	SECTION	COUNTY	TOTAL SHEETS	SHEET NO.
64	(97-2) B-5	WHITE	578	188
CONTRACT NO. 78057				
PUBLIC WATERS		ILLINOIS FED. AID PROJECT		

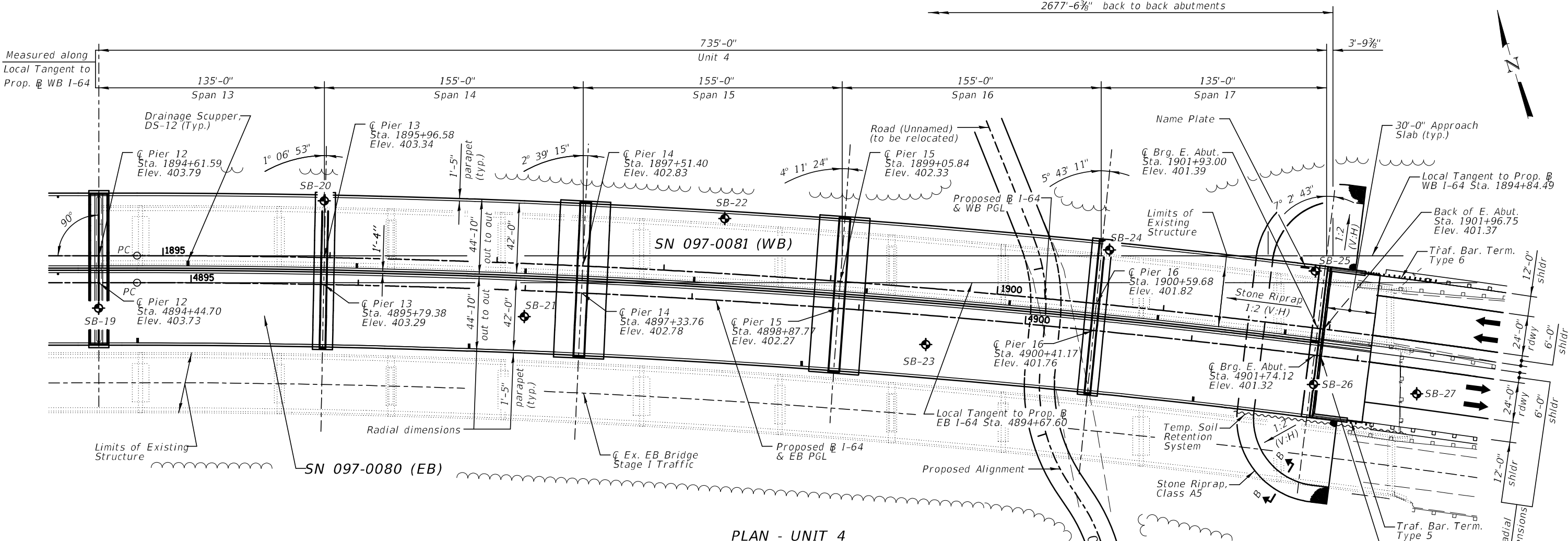
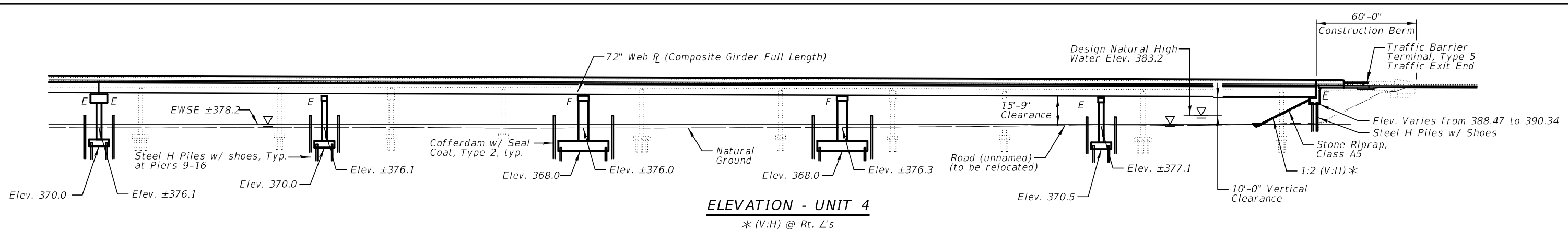

WB SCUPPER LOCATIONS

Station	Offset (ft)
1895+15	6.0
1896+16	6.0
1897+17	6.0
1898+18	6.0
1899+22	6.0
1900+08	6.0
1900+97	6.0
1901+74	6.0

EB SCUPPER LOCATIONS

Station	Offset (ft)
4894+68	36.0
4896+68	36.0
4898+68	36.0
4901+05	36.0

Notes:
 Up to 1/4" may be ground off the bridge deck and approach slabs.
 Drains shall be located clear of all diaphragms.

Legend
 Soil Borings

Note:
 For Section B-B see sheet S-08.

Settlement platforms are to be installed at the locations shown on sheet GR-2. After the removal of the existing slope wall, the proposed embankment shall be stepped in accordance with District 9 Standard 9-16 on sheet D-4.

PLOT DATE = 9/12/2023
 FILE NAME: I:\7601\cadd\Sheet\Bridges\660-50080-GM05.dgn

INDEX OF SHEETS

S-01 Key Plan
 S-02 General Plan and Elevation-Unit 1
 S-03 General Plan and Elevation-Unit 2
 S-04 General Plan and Elevation-Unit 3
 S-05 General Plan and Elevation-Unit 4
 S-06 Index of Sheets
 S-07 General Notes & Total Bill of Material
 S-08 General Data
 S-09 Prestage Construction Details
 S-10 Stage I Construction Details
 S-11 Stage II and III Construction Details
 S-12 Temporary Concrete Barrier
 S-13 Substructure Layout- Spans 1 and 2
 S-14 Substructure Layout- Spans 3 and 4
 S-15 Substructure Layout- Spans 5 and 6
 S-16 Substructure Layout- Spans 7 and 8
 S-17 Substructure Layout- Spans 9 and 10
 S-18 Substructure Layout- Spans 11 and 12
 S-19 Substructure Layout- Spans 13 and 14
 S-20 Substructure Layout- Spans 15 and 16
 S-21 Substructure Layout- Span 17
 S-22 Cofferdam and Seal Coat - 01
 S-23 Cofferdam and Seal Coat - 02
 S-24 Cofferdam and Seal Coat - 03
 S-25 Top of Slab Elevations - Location Plan Spans 1 & 2
 S-26 Top of Slab Elevations - Location Plan Spans 3 & 4
 S-27 Top of Slab Elevations - Location Plan Spans 5 & 6
 S-28 Top of Slab Elevations - Location Plan Spans 7 & 8
 S-29 Top of Slab Elevations - Location Plan Spans 9 & 10
 S-30 Top of Slab Elevations - Location Plan Spans 11 & 12
 S-31 Top of Slab Elevations - Location Plan Spans 13 & 14
 S-32 Top of Slab Elevations - Location Plan Spans 15 & 16
 S-33 Top of Slab Elevations - Location Plan Span 17
 S-34 Top of Slab Elevations (WB)
 S-35 Top of Slab Elevations (WB)
 S-36 Top of Slab Elevations (WB)
 S-37 Top of Slab Elevations (WB)
 S-38 Top of Slab Elevations (WB)
 S-39 Top of Slab Elevations (WB)
 S-40 Top of Slab Elevations (WB)
 S-41 Top of Slab Elevations (WB)
 S-42 Top of Slab Elevations (WB)
 S-43 Top of Slab Elevations (WB)
 S-44 Top of Slab Elevations (WB)
 S-45 Top of Slab Elevations (WB)
 S-46 Top of Slab Elevations (WB)
 S-47 Top of Slab Elevations (WB)
 S-48 Top of Slab Elevations (EB)
 S-49 Top of Slab Elevations (EB)
 S-50 Top of Slab Elevations (EB)
 S-51 Top of Slab Elevations (EB)
 S-52 Top of Slab Elevations (EB)
 S-53 Top of Slab Elevations (EB)
 S-54 Top of Slab Elevations (EB)
 S-55 Top of Slab Elevations (EB)
 S-56 Top of Slab Elevations (EB)
 S-57 Top of Slab Elevations (EB)
 S-58 Top of Slab Elevations (EB)
 S-59 Top of Slab Elevations (EB)
 S-60 Top of Slab Elevations (EB)
 S-61 Top of Slab Elevations (EB)
 S-62 Top of West Approach Slab Elevations
 S-63 Top of East Approach Slab Elevations
 S-64 Deck Plan, Unit 1, Spans 1 & 2 (WB)
 S-65 Deck Plan, Unit 1, Spans 3 & 4 (WB)
 S-66 Parapet Elevations and Cross Section - Unit 1
 S-67 Miscellaneous Details and Bill of Material - Unit 1
 S-68 Deck Plan, Unit 2, Spans 5 & 6 (WB)
 S-69 Deck Plan, Unit 2, Spans 7 & 8 (WB)
 S-70 Parapet Elevations and Cross Section - Unit 2
 S-71 Miscellaneous Details and Bill of Material - Unit 2
 S-72 Deck Plan, Unit 3, Spans 9 & 10 (WB)
 S-73 Deck Plan, Unit 3, Spans 11 & 12 (WB)
 S-74 Parapet Elevations and Cross Section - Unit 3
 S-75 Miscellaneous Details and Bill of Material - Unit 3

INDEX OF SHEETS (cont.)

S-76 Deck Plan, Unit 4, Spans 13 & 14 (WB)
 S-77 Deck Plan, Unit 4, Spans 15 & 16 (WB)
 S-78 Deck Plan, Unit 4, Span 17 (WB)
 S-79 Deck Plan, Unit 4, Spans 13 & 14 (EB)
 S-80 Deck Plan, Unit 4, Spans 15 & 16 (EB)
 S-81 Deck Plan, Unit 4, Span 17 (EB)
 S-82 North Parapet Elevations - Unit 4 (WB)
 S-83 South Parapet Elevations - Unit 4 (WB)
 S-84 North Parapet Elevations - Unit 4 (EB)
 S-85 South Parapet Elevations - Unit 4 (EB)
 S-86 Cross Section - Unit 4
 S-87 Miscellaneous Details and Bills of Material - Unit 4
 S-88 Superstructure Details at Modular Joint - West Abutment
 S-89 Superstructure Details at Modular Joint - Pier 4
 S-90 Superstructure Details at Modular Joint - Pier 8
 S-91 Superstructure Details at Modular Joint - Pier 12
 S-92 Superstructure Details at Modular Joint - East Abutment
 S-93 West Approach Slab Plan
 S-94 West Approach Slab Details
 S-95 West Approach Slab Details and Bill of Material
 S-96 East Approach Slab Plan
 S-97 East Approach Slab Details
 S-98 East Approach Slab Details and Bill of Material
 S-99 Drainage Scupper, DS-12
 S-100 Modular Expansion Joint Details - West Abutment
 S-101 Modular Expansion Joint Details - Pier 4
 S-102 Modular Expansion Joint Details - Pier 8
 S-103 Modular Expansion Joint Details - Pier 12
 S-104 Modular Expansion Joint Details - East Abutment
 S-105 Modular Expansion Joint Details - Sliding Plate Detail
 S-106 Framing Plan & Elevation - Unit 1
 S-107 Framing Plan & Elevation - Unit 2
 S-108 Framing Plan & Elevation - Unit 3
 S-109 Framing Plan & Elevation - Unit 4, Spans 13-15 (WB)
 S-110 Framing Plan & Elevation - Unit 4, Spans 16-17 (WB)
 S-111 Framing Plan & Elevation - Unit 4, Spans 13-15 (EB)
 S-112 Framing Plan & Elevation - Unit 4, Spans 16-17 (EB)
 S-113 Framing Plan Details - Unit 4
 S-114 Framing Plan Details - Unit 4
 S-115 Interior and End Cross Frame Details
 S-116 Top of Web Elevation Tables
 S-117 Camber Diagrams
 S-118 Field Splice Details
 S-119 Field Splice Details
 S-120 Field Splice Details
 S-121 Field Splice Details
 S-122 Moment and Reaction Tables - Units 1 & 2
 S-123 Moment and Reaction Tables - Units 3 & 4
 S-124 Bearing Details - Elastomeric Bearings Type I
 S-125 Bearing Details - Elastomeric Bearings Type II
 S-126 Bearing Details - Fixed HLMR Disc Bearing
 S-127 Bearing Details - Guided Expansion HLMR Disc Bearing
 S-128 West Abutment Plan
 S-129 West Abutment Elevation and Section
 S-130 West Abutment Wingwall Details
 S-131 West Abutment Rebar Details
 S-132 East Abutment Plan
 S-133 East Abutment Elevation and Section
 S-134 East Abutment Wingwall Details
 S-135 East Abutment Rebar Details
 S-136 Pier No. 1 Plan and Elevation
 S-137 Pier No. 1 Partial Plan and Elevation (WB)
 S-138 Pier No. 1 Transfer Beam Partial Plan and Elevation (WB)
 S-139 Pier No. 1 Drilled Shaft Elevation and Details
 S-140 Pier No. 1 Reinforcement Details and Bill of Material
 S-141 Pier No. 2 Plan and Elevation
 S-142 Pier No. 2 Partial Plan and Elevation (WB)
 S-143 Pier No. 2 Transfer Beam Partial Plan and Elevation (WB)
 S-144 Pier No. 2 Drilled Shaft Elevation and Details
 S-145 Pier No. 2 Reinforcement Details and Bill of Material
 S-146 Pier No. 3 Plan and Elevation
 S-147 Pier No. 3 Partial Plan and Elevation (WB)
 S-148 Pier No. 3 Transfer Beam Partial Plan and Elevation
 S-149 Pier No. 3 Drilled Shaft Elevation and Details
 S-150 Pier No. 3 Reinforcement Details and Bill of Material

INDEX OF SHEETS (cont.)

S-151 Pier No. 4 Plan and Elevation
 S-152 Pier No. 4 Partial Plan and Elevation (WB)
 S-153 Pier No. 4 Transfer Beam Partial Plan and Elevation (WB)
 S-154 Pier No. 4 Drilled Shaft Elevation and Details
 S-155 Pier No. 4 Reinforcement Details and Bill of Material
 S-156 Pier No. 5 Plan and Elevation
 S-157 Pier No. 5 Partial Plan and Elevation (WB)
 S-158 Pier No. 5 Transfer Beam Partial Plan and Elevation (WB)
 S-159 Pier No. 5 Drilled Shaft Elevation and Details
 S-160 Pier No. 5 Reinforcement Details and Bill of Material
 S-161 Pier No. 6 Plan and Elevation
 S-162 Pier No. 6 Partial Plan and Elevation (WB)
 S-163 Pier No. 6 Transfer Beam Partial Plan and Elevation (WB)
 S-164 Pier No. 6 Drilled Shaft Elevation and Details
 S-165 Pier No. 6 Reinforcement Details and Bill of Material
 S-166 Pier No. 7 Plan and Elevation
 S-167 Pier No. 7 Partial Plan and Elevation (WB)
 S-168 Pier No. 7 Transfer Beam Partial Plan and Elevation (WB)
 S-169 Pier No. 7 Drilled Shaft Elevation and Details
 S-170 Pier No. 7 Reinforcement Details and Bill of Material
 S-171 Pier No. 8 Plan and Elevation
 S-172 Pier No. 8 Partial Plan and Elevation (WB)
 S-173 Pier No. 8 Transfer Beam Partial Plan and Elevation (WB)
 S-174 Pier No. 8 Drilled Shaft Elevation and Details
 S-175 Pier No. 8 Reinforcement Details and Bill of Material
 S-176 Pier No. 9 Plan and Elevation
 S-177 Pier No. 9 Footing Layout
 S-178 Pier No. 9 Anchor Bolt Layout
 S-179 Pier No. 9 Details
 S-180 Pier No. 10 Plan and Elevation
 S-181 Pier No. 10 Footing Layout
 S-182 Pier No. 10 Anchor Bolt Layout
 S-183 Pier No. 10 Details
 S-184 Pier No. 11 Plan and Elevation
 S-185 Pier No. 11 Footing Layout
 S-186 Pier No. 11 Anchor Bolt Layout
 S-187 Pier No. 11 Details
 S-188 Pier No. 12 Plan and Elevation
 S-189 Pier No. 12 Footing Layout
 S-190 Pier No. 12 Anchor Bolt Layout
 S-191 Pier No. 12 Details
 S-192 Pier No. 13 Plan and Elevation
 S-193 Pier No. 13 Footing Layout
 S-194 Pier No. 13 Anchor Bolt Layout
 S-195 Pier No. 13 Details
 S-196 Pier No. 14 Plan and Elevation
 S-197 Pier No. 14 Footing Layout
 S-198 Pier No. 14 Anchor Bolt Layout
 S-199 Pier No. 14 Details
 S-200 Pier No. 15 Plan and Elevation
 S-201 Pier No. 15 Footing Layout
 S-202 Pier No. 15 Anchor Bolt Layout
 S-203 Pier No. 15 Details
 S-204 Pier No. 16 Plan and Elevation
 S-205 Pier No. 16 Footing Layout
 S-206 Pier No. 16 Anchor Bolt Layout
 S-207 Pier No. 16 Details
 S-208 HP Pile Details
 S-209 Bar Splicer Assembly and Mechanical Splicer Details

INDEX OF SHEETS (cont.)

S-210 Soil Boring Logs
 S-211 Soil Boring Logs
 S-212 Soil Boring Logs
 S-213 Soil Boring Logs
 S-214 Soil Boring Logs
 S-215 Soil Boring Logs
 S-216 Soil Boring Logs
 S-217 Soil Boring Logs
 S-218 Soil Boring Logs
 S-219 Soil Boring Logs
 S-220 Soil Boring Logs
 S-221 Soil Boring Logs
 S-222 Soil Boring Logs
 S-223 Soil Boring Logs
 S-224 Soil Boring Logs
 S-225 Soil Boring Logs
 S-226 Soil Boring Logs
 S-227 Soil Boring Logs
 S-228 Soil Boring Logs
 S-229 Soil Boring Logs
 S-230 Soil Boring Logs
 S-231 Soil Boring Logs
 S-232 Soil Boring Logs

For Existing Bridge Plans, see Sheets SX-1 thru SX-51 immediately following sheet 232

PLOT DATE = 8/9/2023
 FILE NAME = L:\7660\CADD\Sheets\Bridges\7660-0080-EN05.dgn

KNIGHT Engineers & Architects	DESIGNED - KA	REVISED
	CHECKED - LS	REVISED
	SCALE - NONE	REVISED
	DATE - 8/11/2023	REVISED

**STATE OF ILLINOIS
DEPARTMENT OF TRANSPORTATION**

INDEX OF SHEETS
STRUCTURE NUMBER 097-0080 (EB) AND 097-0081 (WB)
 SHEET S-06 OF 232 SHEETS

F.A.I. RTE.	SECTION	COUNTY	TOTAL SHEETS	SHEET NO.
64	(97-2) B-5	WHITE	578	190
CONTRACT NO. 78057				
PUBLIC WATERS		ILLINOIS	FED. AID PROJECT	

GENERAL NOTES:

Fasteners shall be ASTM F 3125 Grade A325 Type 1, mechanically galvanized bolts in coated metalized areas. Fasteners shall be ASTM F 3125 Grade A325 Type 3 weathering steel bolts in unpainted areas. Bolts 7/8" dia., holes 1 1/16" dia., unless otherwise noted.

Calculated weight of Structural Steel = EB 1-64: 5,762,900 pound WB 1-64: 5,773,140 pound

All structural steel shall be AASHTO M270 Grade 50W (except expansion joints and bearings which shall be AASHTO M270 Grade 50).

All structural steel within a distance of 15 ft. each way from the deck joints and the exposed surfaces of all bearings shall be metalized.

No field welding is permitted except as specified in the contract documents.

Reinforcement bars designated (E) shall be epoxy coated.

If the Contractor elects to use cantilever forming brackets on the exterior beams or girders, the brackets shall be placed at the same locations as required for the hardwood blocks in Article 503.06(b) of the Standard Specifications. If additional cantilever forming brackets are required, hardwood blocking shall be wedged between the exterior and first interior beam at each of these additional bracket locations.

Bearing seat surfaces shall be constructed or adjusted to the designated elevations within a tolerance of 1/8 in. (0.01 ft.). Adjustment shall be made either by grinding the surface or by shimmed the bearings.

A film forming Concrete Sealer shall be applied to the horizontal surfaces of the bridge seats of both Abutments and Piers 4, 8, and 12. A penetrating Concrete Sealer shall be applied to the exposed vertical surfaces of both abutments, including the backwall and front face of abutments, and the vertical faces of pier caps at Piers 4, 8, and 12. Concrete Sealers shall be applied prior to setting bearings and girders.

The existing structural steel coating contains lead. The Contractor shall take appropriate precautions to deal with the presence of lead on this project.

Layout of the slope protection system may be varied to suit ground conditions in the field as directed by the Engineer.

The embankment configuration shown shall be the minimum that must be placed and compacted prior to construction of the abutments.

Concrete for the Drilled Shafts shall be in accordance with Section 516 of the Standard Specifications except that the mix design shall attain a compressive strength of 7,000 psi at 14 days.

All reinforcement bars in the Drilled Shafts shall be ASTM A706 Grade 80.

The Estimated Water Surface Elevation (EWSE) was set to equal the 5 year natural high water elevation.

GENERAL NOTES: (cont.)

The Contractor shall obtain a construction permit from the Illinois Department of Natural Resources (IDNR), Office of Water Resources for any temporary construction activity placed in the water except cofferdams. This shall include the placement of material for run-arounds, causeways, etc. Any permit application by the Contractor shall refer to the IDNR 3704 Floodway Construction permit number allowing permanent construction as shown in the contract plans.

The Seal coat design thickness is based on the Cofferdam Design Water Elevation (CDWE) shown. Final Cofferdam design, details and seal coat thickness shall be submitted to the Engineer for approval. The CDWE is equal to the Estimated Water Surface Elevation (EWSE) plus 3 feet.

Slipforming of the parapets is not allowed.

The Contractor shall retain the services of an engineering firm, prequalified in the IDOT consultant selection category of Highway Bridges (Advanced Typical), for preparation of the Structural Assessment Report(s). Contractor's pre-approval shall not be applicable for this project. See Special Provision.

Current Ratings on File for Existing Structure: Inventory: HS18 Operating: HS30

Live Load Restrictions: No

Inventory and Operating Ratings and Live Load Restrictions are provided for information only. Inventory and Operating Ratings are based on HS loading and configuration. Live Load Restrictions are based on Illinois legal loads and configurations. The Ratings and Live Load Restrictions are not necessarily representative of capacities to support the Contractor's equipment.

Partial depth patching quantity for the existing Eastbound Bridge SN 097-0003 is estimated. Locations of patching shall be as directed by the Engineer in the field. Patching shall be completed prior to Stage I traffic.

TOTAL BILL OF MATERIAL SN 097-0080

Table with 5 columns: ITEM, UNIT, SUPER, SUB, TOTAL. Lists materials like Stone Riprap, Filter Fabric, Cofferdam, Concrete Structures, etc.

TOTAL BILL OF MATERIAL SN 097-0081

Table with 5 columns: ITEM, UNIT, SUPER, SUB, TOTAL. Lists materials like Stone Riprap, Filter Fabric, Cofferdam, Concrete Structures, etc.

Plot Date = 12/11/2023 File Name: L:\7660\CADD\Sheets\Bridges\7660-50080-GN07.dgn



Table with 2 columns: Field (SCALE, DATE) and Value (NONE, 8/11/2023)

Table with 2 columns: Field (DESIGNED, CHECKED, DRAWN, CHECKED) and Value (KA, LS, KA, LS)

Table with 2 columns: Field (REVISED) and Value (12/11/2023)

STATE OF ILLINOIS DEPARTMENT OF TRANSPORTATION

GENERAL NOTES AND TOTAL BILL OF MATERIAL STRUCTURE NUMBER 097-0080 (EB) AND 097-0081 (WB)

SHEET 5-07 OF 232 SHEETS

Table with 5 columns: F.A.I. RTE., SECTION, COUNTY, TOTAL SHEETS, SHEET NO. Values: 64, (97-2)B-5, WHITE, 578, 191

PUBLIC WATERS ILLINOIS FED. AID PROJECT CONTRACT NO. 78057

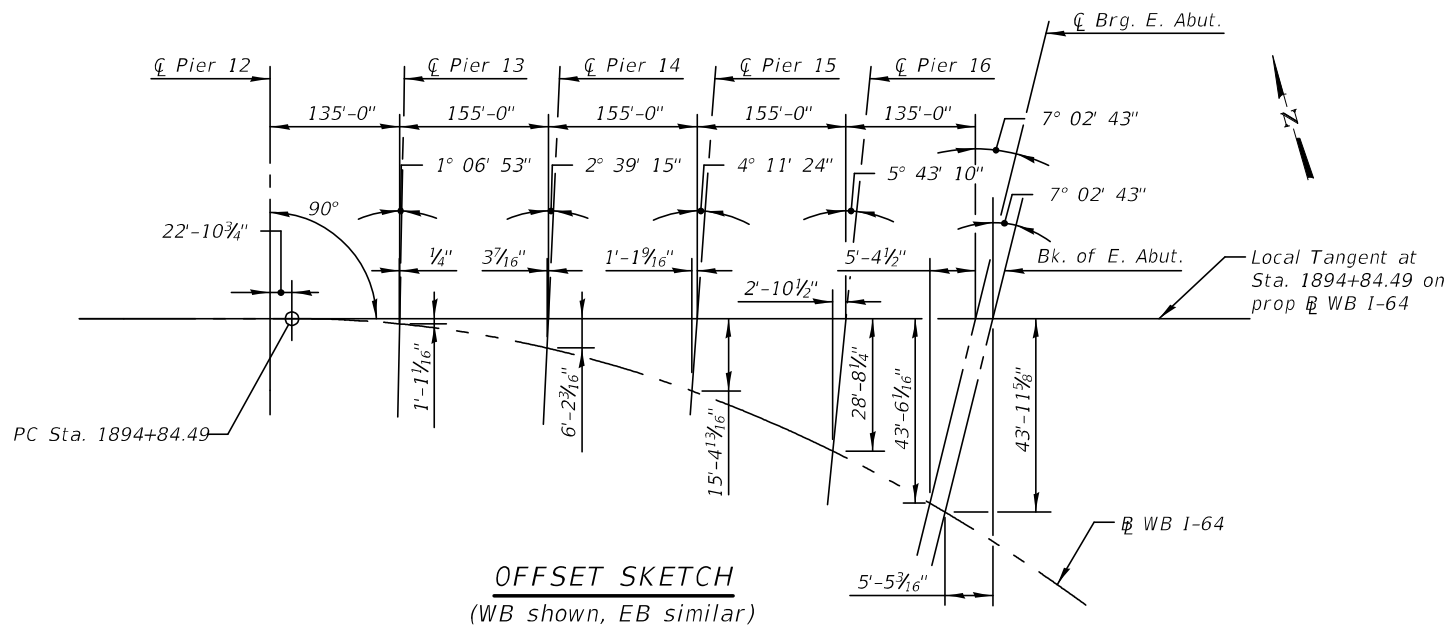

OFFSET SKETCH
(WB shown, EB similar)

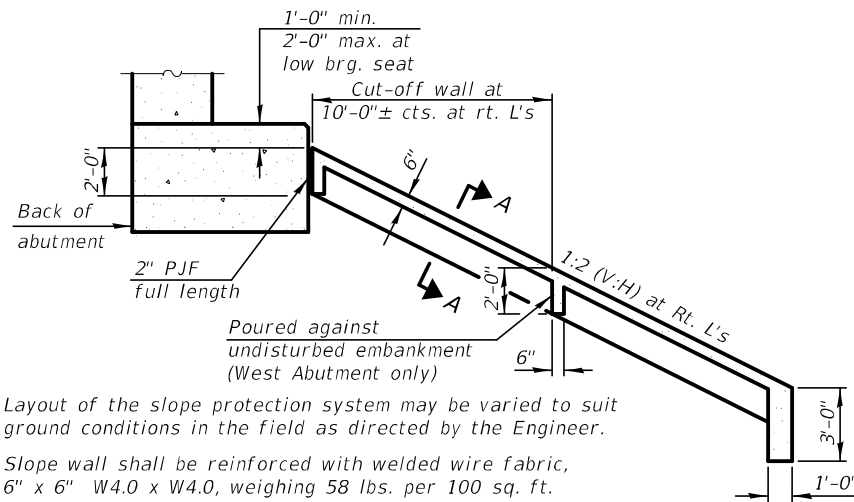

SECTION THRU
SLOPEWALL 6 INCH

Layout of the slope protection system may be varied to suit ground conditions in the field as directed by the Engineer.

Slope wall shall be reinforced with welded wire fabric, 6" x 6" W4.0 x W4.0, weighing 58 lbs. per 100 sq. ft.

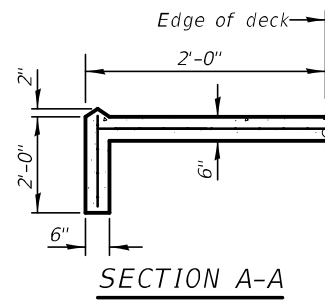

SECTION A-A

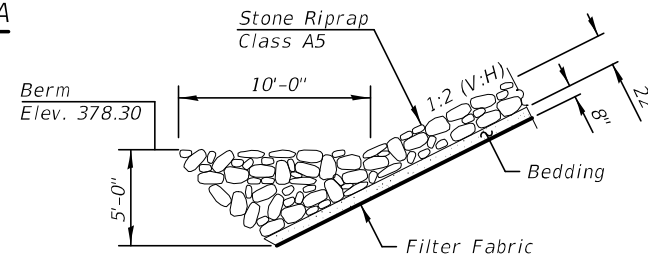

SECTION B-B

Slope Wall 6 Inch (West Abutment)
Stone Riprap, Class A5 (East Abutment)
See Section B-B

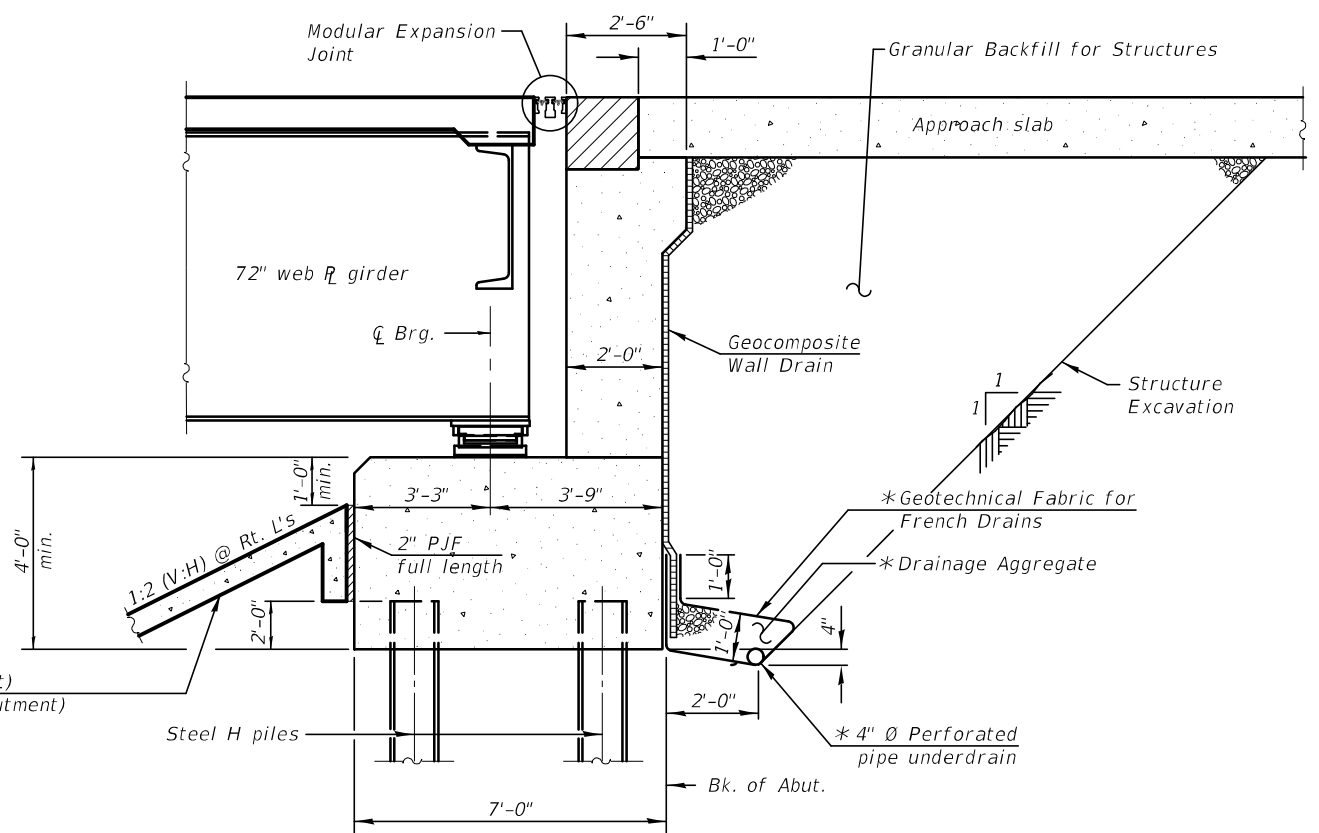

SECTION THRU PILE SUPPORTED STUB ABUTMENT
(Horiz. dim. @ Rt. L's)

* Included in the cost of Pipe Underdrains for Structures

All drainage system components shall extend parallel to the abutment back wall until they intersect the wingwalls. The pipe shall extend under the wingwall until intersecting the side slopes. The pipes shall drain into concrete heawalls. (See Article 601.05 of the Standard Specifications and Highway Standard 601101)

Notes:

For Location of Section A-A see sheet S-02.
For Location of Section B-B see sheet S-05.

WATERWAY INFORMATION

		Existing Overtopping Elev. = 392.06 at Sta. 86+50 (Indiana)		Proposed Overtopping Elev. = 392.06 at Sta. 86+50 (Indiana)						
Drainage Area = 29,070 sq. mi.		Freq. Yr.	Q C.F.S.	Opening Sq. Ft. Exist.	Opening Sq. Ft. Prop.	Nat. H.W.E.	Head - Ft. Exist.	Head - Ft. Prop.	Headwater El. Exist.	Headwater El. Prop.
Design	Main Channel	50	282277	41746	41844	383.2	1.3	1.3	384.5	384.5
	Relief Structure			5747	5747					
	TOTAL			47493	47591					
Base	Main Channel	100	312019	45027	44663	384.5	1.4	1.4	385.9	385.9
	Relief Structure			6419	6419					
	TOTAL			51446	51082					
Scour Check	Main Channel	200	340000	47573	47067	385.5	1.5	1.5	387.0	387.0
	Relief Structure			6942	6942					
	TOTAL			54515	54009					
Overtopping	Main Channel	N/A	N/A	N/A	N/A	N/A	N/A	N/A	N/A	N/A
	Relief Structure			N/A	N/A					
	TOTAL			N/A	N/A					
Max Calc	Main Channel	500	380000	50881	50408	386.8	1.6	1.6	388.4	388.4
	Relief Structure			7630	7630					
	TOTAL			58511	58038					

10 Year Velocity Through Existing Bridge = 5.8 ft/s
10 Year Velocity Through Proposed Bridge = 5.8 ft/s

DESIGN SCOUR ELEVATIONS (FT.)

Event/Limit State	Design Scour Elevations (ft.)									Item 113
	W. Abut.	Pier 1	Pier 2	Pier 3	Pier 4	Pier 5	Pier 6	Pier 7	Pier 8	
Q100	398.22	356.2	343.6	326.0	316.6	316.0	310.9	307.8	305.3	5
Q200	398.22	356.0	343.4	325.8	316.4	315.8	310.6	307.5	305.0	
Design	398.22	356.2	343.6	326.0	316.6	316.0	310.9	307.8	305.3	
Check	398.22	356.0	343.4	325.8	316.4	315.8	310.6	307.5	305.0	

Event/Limit State	Design Scour Elevations (ft.)									Item 113
	Pier 9	Pier 10	Pier 11	Pier 12	Pier 13	Pier 14	Pier 15	Pier 16	E. Abut.	
Q100	347.9	350.1	351.6	353.9	352.1	353.4	350.6	345.3	388.47	5
Q200	346.2	348.6	350.1	352.5	350.7	352.0	349.0	343.4	388.47	
Design	347.9	350.1	351.6	353.9	352.1	353.4	350.6	345.3	388.47	
Check	346.2	348.6	350.1	352.5	350.7	352.0	349.0	343.4	388.47	

STATION 4888+41.96
BUILT 20__ BY
STATE OF ILLINOIS
F.A.I. RT. 64 SEC. (97-2)B-5
LOADING HL-93
STRUCTURE NO. 097-0080

STATION 1888+59.80
BUILT 20__ BY
STATE OF ILLINOIS
F.A.I. RT. 64 SEC. (97-2)B-5
LOADING HL-93
STRUCTURE NO. 097-0081

NAME PLATE
See Std. 515001

PLOT DATE = 9/7/2023
FILE NAME = I:\7660\CAD\Sheets\Bridges\7660-50080-GN08.dgn

KNIGHT
Engineers & Architects

DESIGNED - KA	REVISION 09/08/2023
CHECKED - LS	REVISED
SCALE - NONE	DRAWN - KA
DATE - 8/11/2023	CHECKED - LS
	REVISED

STATE OF ILLINOIS
DEPARTMENT OF TRANSPORTATION

GENERAL DATA
STRUCTURE NUMBER 097-0080 (EB) AND 097-0081 (WB)
SHEET S-08 OF 232 SHEETS

F.A.I. RTE.	SECTION	COUNTY	TOTAL SHEETS	SHEET NO.
64	(97-2)B-5	WHITE	578	192
CONTRACT NO. 78057				
PUBLIC WATERS		ILLINOIS FED. AID PROJECT		

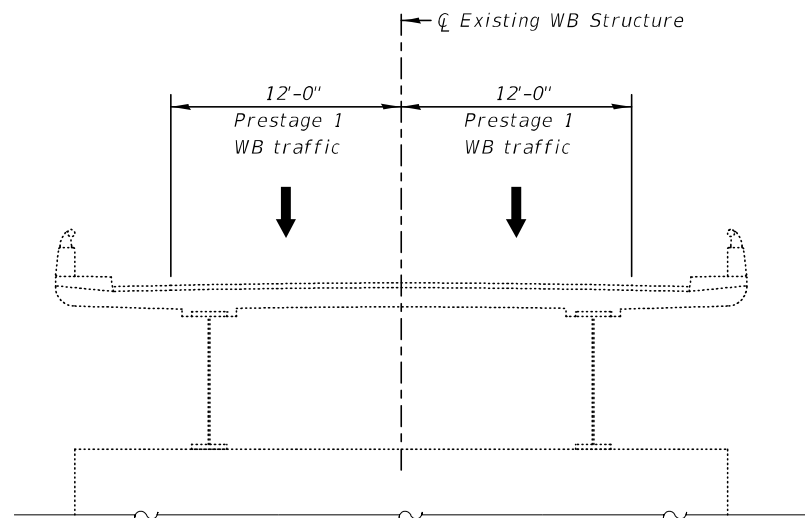

WESTBOUND STRUCTURE
(Showing existing main span)

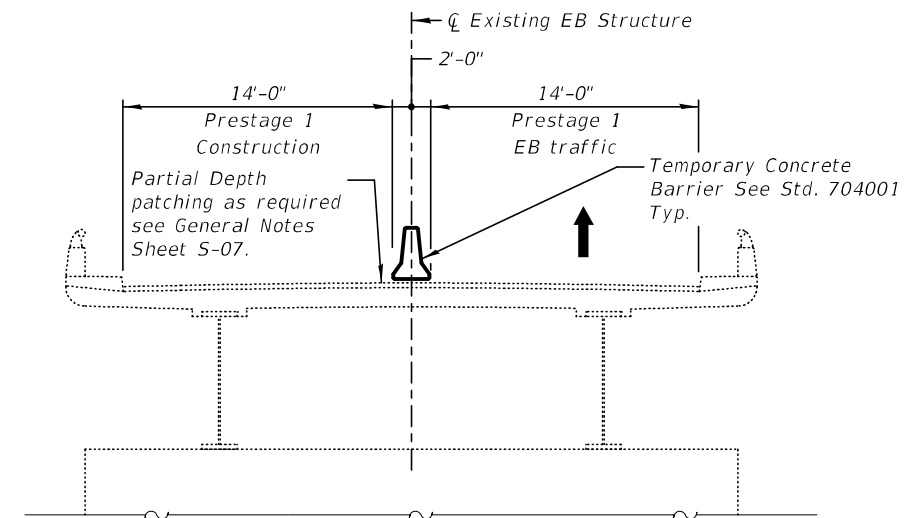

EASTBOUND STRUCTURE
(Showing existing main span)

PRESTAGE 1
(Looking East)

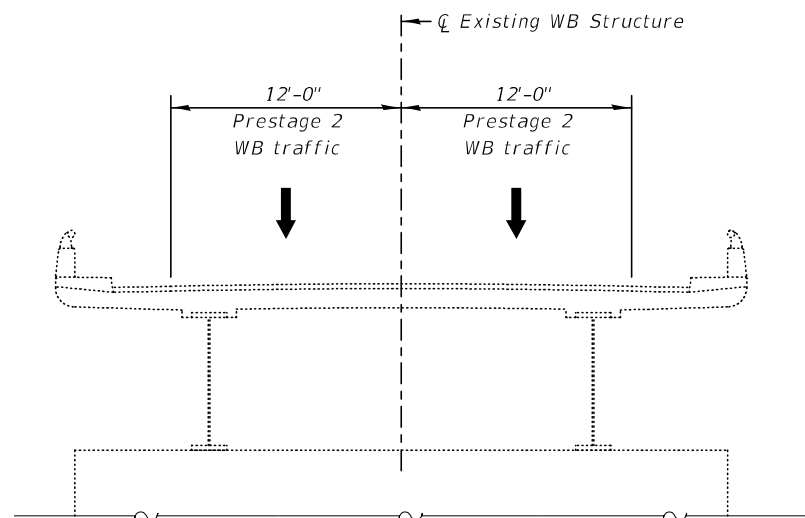

WESTBOUND STRUCTURE
(Showing existing main span)

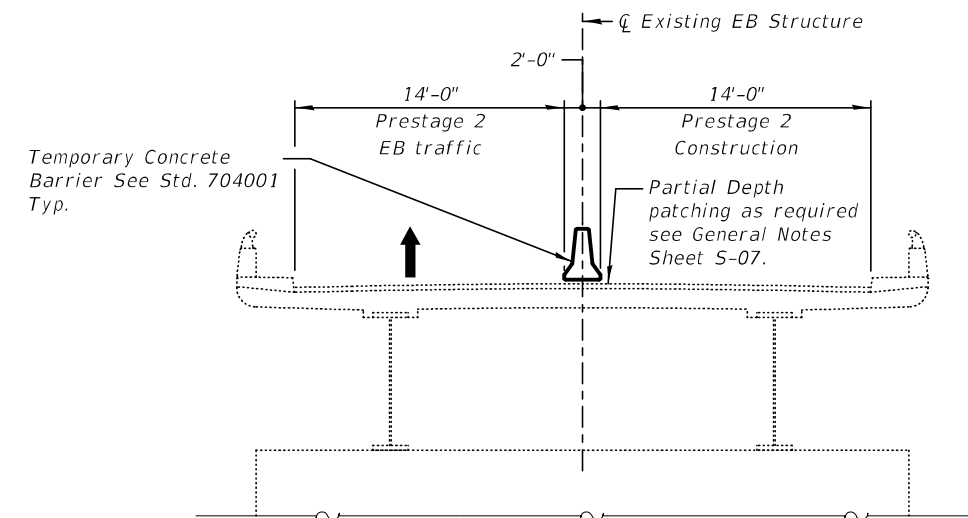

EASTBOUND STRUCTURE
(Showing existing main span)

PRESTAGE 2
(Looking East)

Notes:
Lane closure per Highway Standards 701400 and 701402.

PLOT DATE = 8/9/2023
FILE NAME: L:\7660\CAD\1\Sheets\Bridges\7660-50080-GW09a.dgn



DESIGNED - KA	REVISED
CHECKED - LS	REVISED
SCALE - NONE	DRAWN - KA
DATE - 8/11/2023	CHECKED - LS
	REVISED

STATE OF ILLINOIS
DEPARTMENT OF TRANSPORTATION

PRESTAGE CONSTRUCTION DETAILS
STRUCTURE NUMBER 097-0080 (EB) AND 097-0081 (WB)

SHEET S-09 OF 232 SHEETS

F.A.I. RTE.	SECTION	COUNTY	TOTAL SHEETS	SHEET NO.
64	(97-2) B-5	WHITE	578	193
CONTRACT NO. 78057				
PUBLIC WATERS		ILLINOIS FED. AID PROJECT		

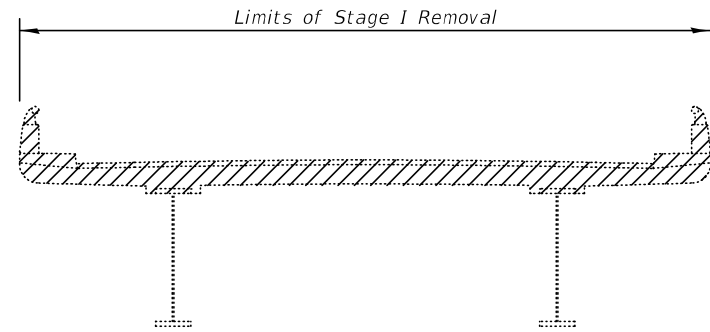

WESTBOUND STRUCTURE
(Showing existing main span)

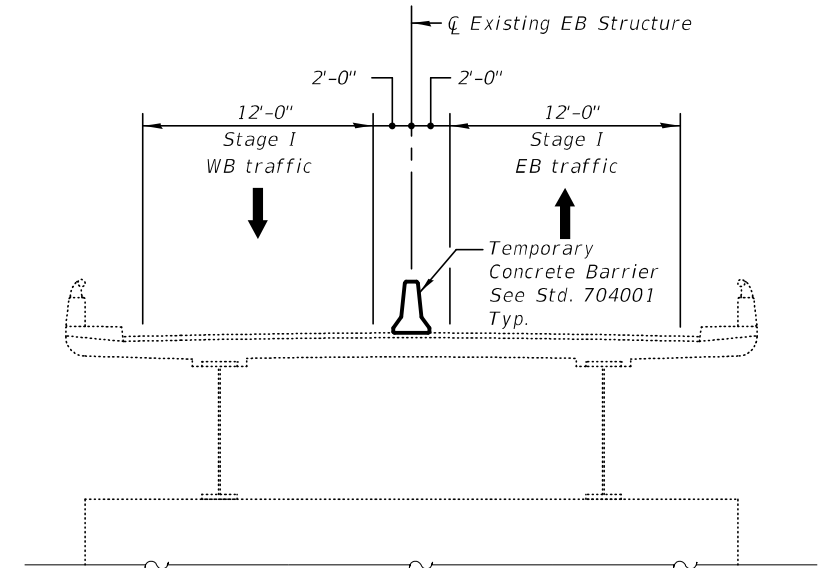

EASTBOUND STRUCTURE
(Showing existing main span)

STAGE I REMOVAL
(Looking East)

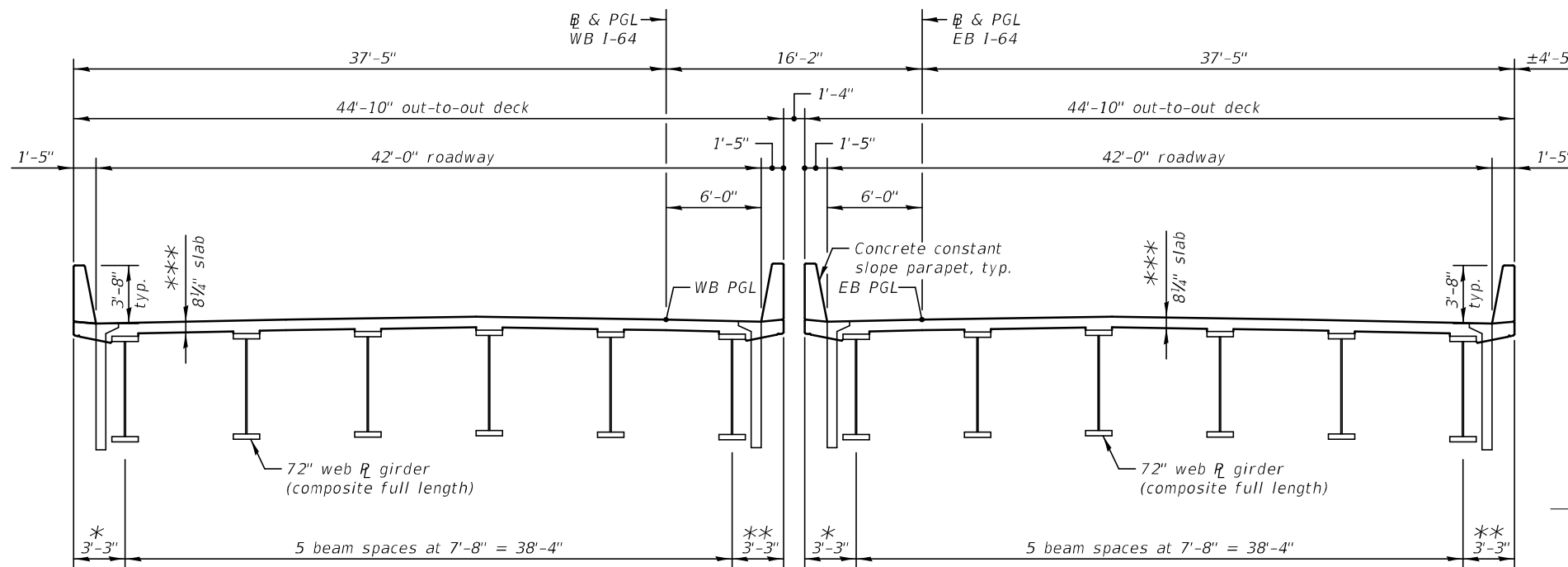

SN 097-0081 (WB)

SN 097-0080 (EB)

STAGE I CONSTRUCTION
(Looking East)

*** Prior to grinding

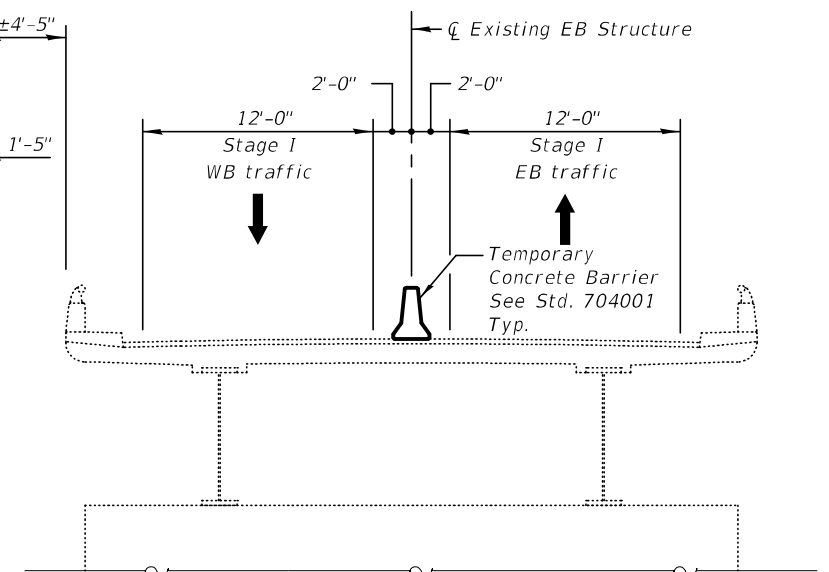

EASTBOUND STRUCTURE
(Showing existing main span)

Span 13 - Overhang Varies

Sta 1894+61.59 to PC Sta 1894+84.49 (WB)

Sta 4894+44.70 to PC Sta 4894+67.60 (EB)

* varies 3'-3 1/2" to 3'-3"

** varies 3'-2 1/2" to 3'-3"

Legend

 Removal of Existing Structure

PLOT DATE = 8/9/2023
FILE NAME: I:\7660\CAD\Sheets\Bridges\7660-50080-GN09.dgn

KNIGHT
Engineers & Architects

DESIGNED - KA	REVISION
CHECKED - LS	REVISION
DRAWN - KA	REVISION
CHECKED - LS	REVISION
SCALE - NONE	
DATE - 8/11/2023	

STATE OF ILLINOIS
DEPARTMENT OF TRANSPORTATION

STAGE I CONSTRUCTION DETAILS
STRUCTURE NUMBER 097-0080 (EB) AND 097-0081 (WB)

SHEET S-10 OF 232 SHEETS

F.A.I. RTE.	SECTION	COUNTY	TOTAL SHEETS	SHEET NO.
64	(97-2) B-5	WHITE	578	194
CONTRACT NO. 78057				
PUBLIC WATERS		ILLINOIS FED. AID PROJECT		

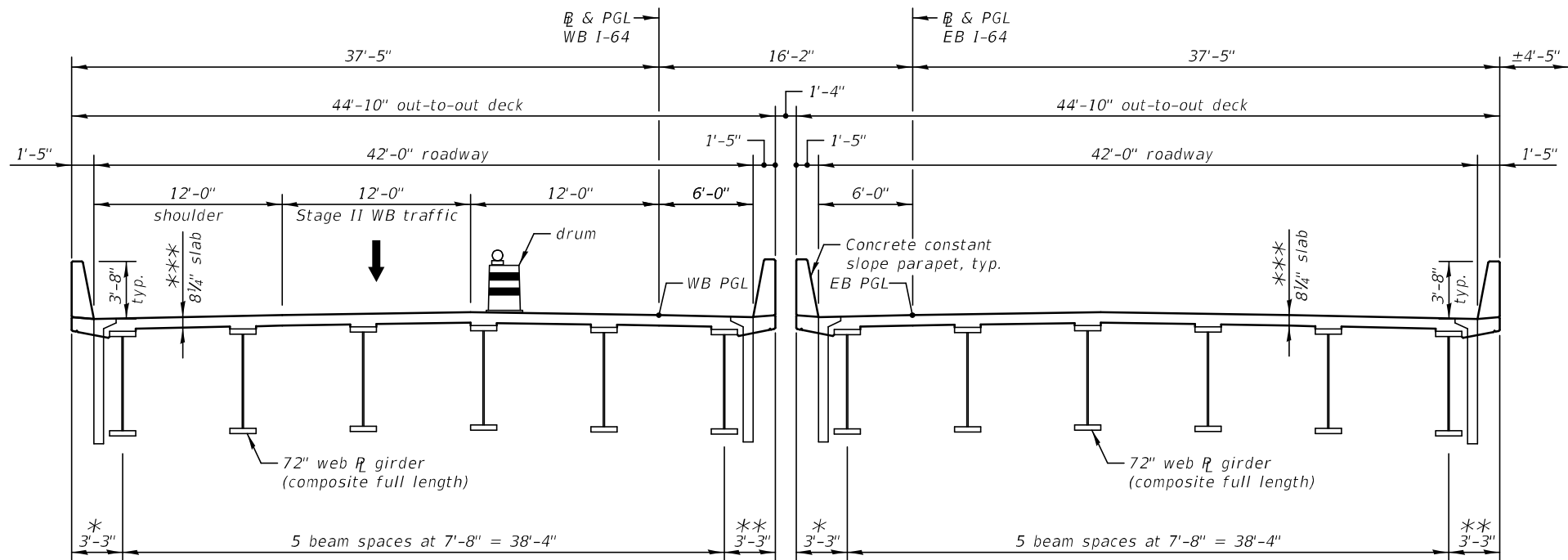

SN 097-0081 (WB)

SN 097-0080 (EB)

STAGE II CONSTRUCTION
(Looking East)

Note:

Stage II Construction consists of roadway work outside the limits of the structure. Stage II WB traffic will travel on the outside lane of the Proposed WB Structure, while the EB traffic will travel on the outside lane of the Existing EB structure.

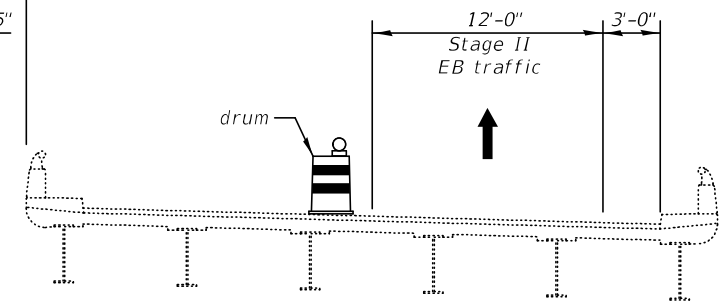

EASTBOUND STRUCTURE
(Showing existing approach span)

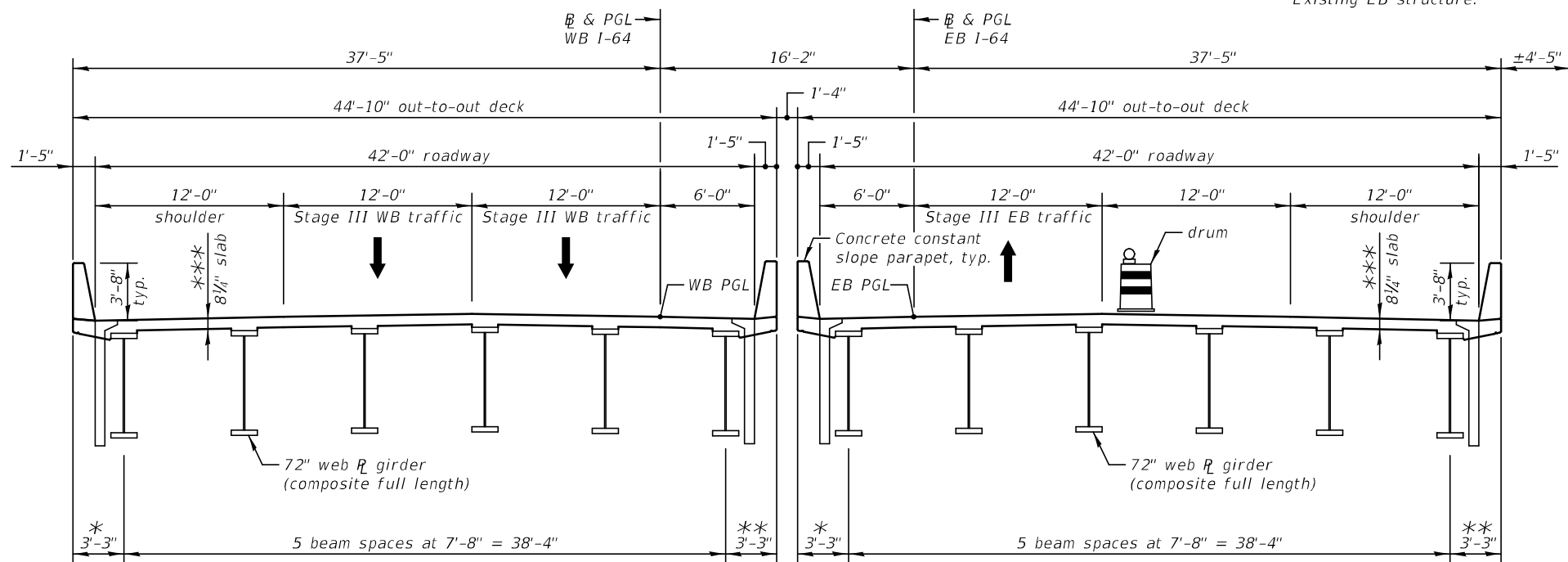

SN 097-0081 (WB)

SN 097-0080 (EB)

STAGE III CONSTRUCTION & REMOVAL
(Looking East)

*** Prior to grinding

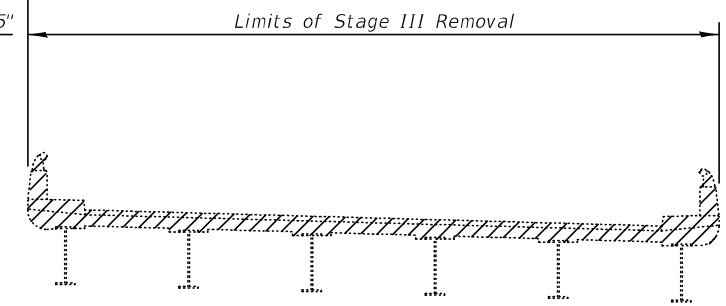

EASTBOUND STRUCTURE
(Showing existing approach span)

Span 13 - Overhang Varies

Sta 1894+61.59 to PC Sta 1894+84.49 (WB)

Sta 4894+44.70 to PC Sta 4894+67.60 (EB)

* varies 3'-3 1/2" to 3'-3"

** varies 3'-2 1/2" to 3'-3"

Legend

Removal of Existing Structure

PLOT DATE = 8/9/2023
FILE NAME = I:\76601\cadd\Sheets\Bridges\7660-50080-CN10.dgn

KNIGHT
Engineers & Architects

DESIGNED - KA	REVISION
CHECKED - LS	REVISION
SCALE - NONE	REVISION
DATE - 8/11/2023	REVISION
DRAWN - KA	REVISION
CHECKED - LS	REVISION

STATE OF ILLINOIS
DEPARTMENT OF TRANSPORTATION

STAGE II & III CONSTRUCTION DETAILS
STRUCTURE NUMBER 097-0080 (EB) AND 097-0081 (WB)

SHEET S-11 OF 232 SHEETS

F.A.I. RTE.	SECTION	COUNTY	TOTAL SHEETS	SHEET NO.
64	(97-2) B-5	WHITE	578	195
CONTRACT NO. 78057				
PUBLIC WATERS	ILLINOIS	FED. AID PROJECT		

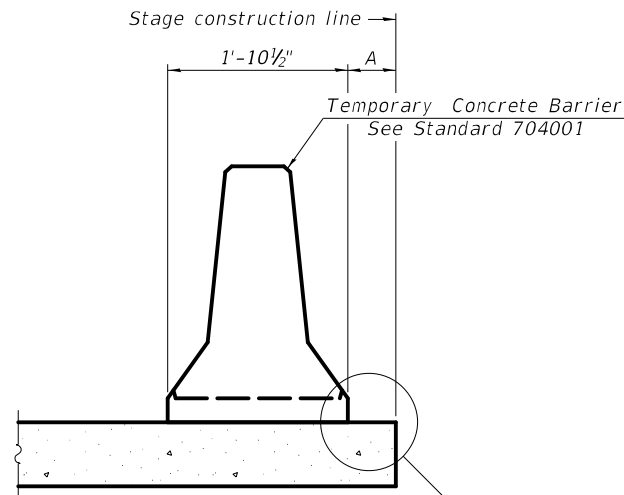

When "A" is 3'-1" or less, the temporary concrete barrier shall be restrained to the new slab according to Detail I, II or III. No restraint is required when "A" is greater than 3'-1".

NEW SLAB OR NEW DECK BEAM

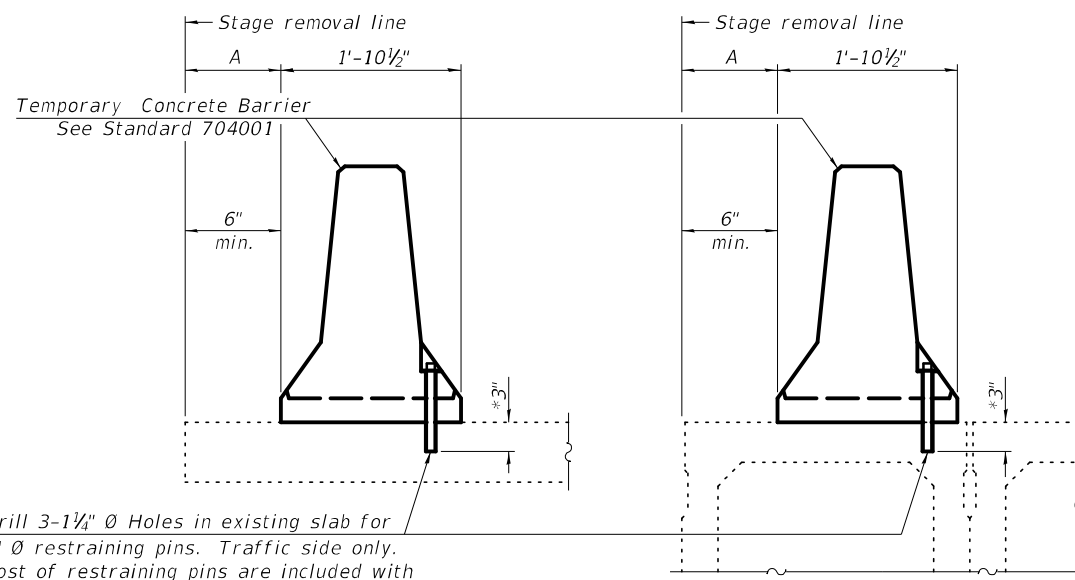

Drill 3-1 1/4" Ø Holes in existing slab for 1" Ø restraining pins. Traffic side only. Cost of restraining pins are included with Temporary Concrete Barrier. No restraint is required when "A" is greater than 3'-1".

EXISTING SLAB

EXISTING DECK BEAM

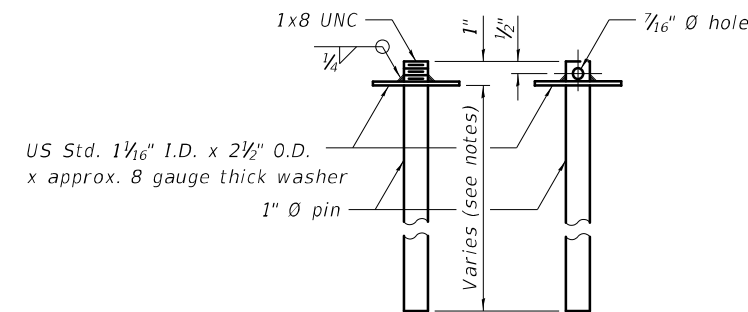

RESTRAINING PIN

* When hot-mix asphalt wearing surface is present, embedment shall be 3" plus the wearing surface depth.

SECTIONS THRU SLAB OR DECK BEAM

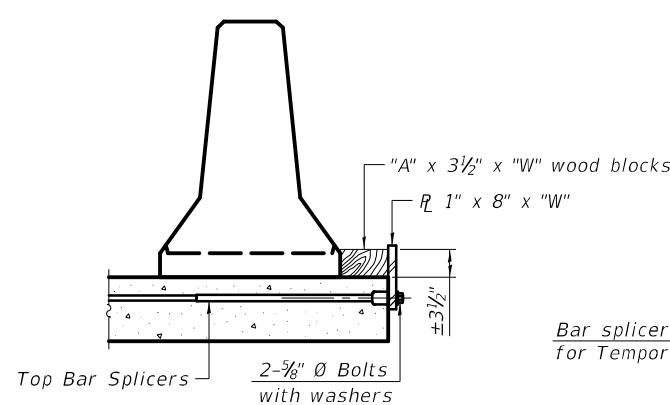

DETAIL I

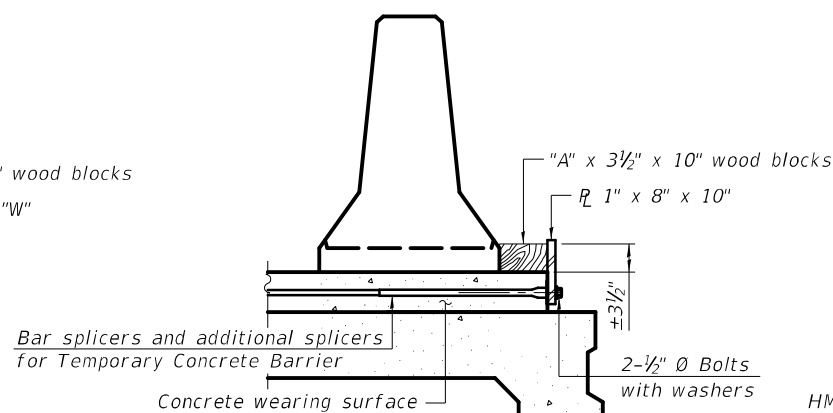

DETAIL II

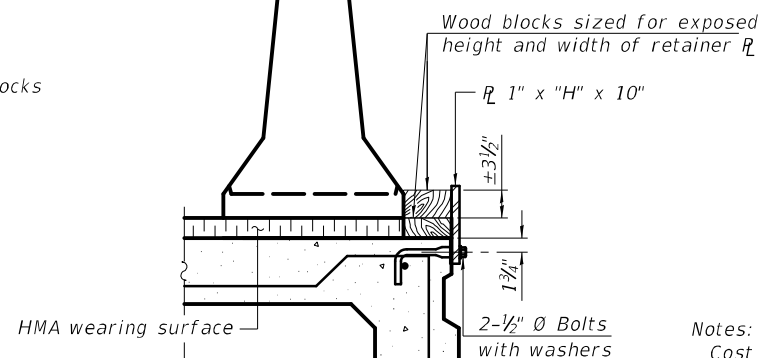

DETAIL III

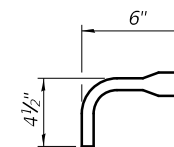

BAR SPLICER FOR #4 BAR - DETAIL III

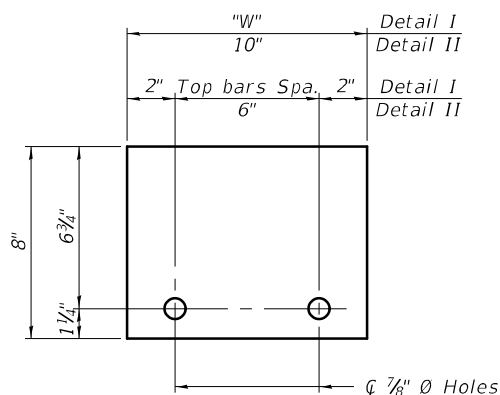

STEEL RETAINER R 1" x 8" x "W"
(Detail I and II)

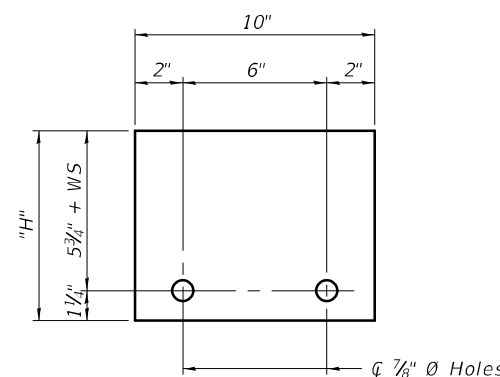

STEEL RETAINER R 1" x "H" x 10"
(Detail III)

Notes:
 Cost of retainer assembly is included with Temporary Concrete Barrier.
 A retainer assembly shall be located at the approximate \bar{C} of each temporary concrete barrier.
 The retainer plate shall not be removed until the concrete on the adjacent stage is ready to be poured. For Detail III applications the retainer plate shall not be removed until just prior to placing the adjacent beam.
 When the 'A' dimension is less than 1 1/2', the wood block shall be omitted and the barrier shall be placed in direct contact with the steel retainer plate. For deck beam applications the minimum required 'A' distance is 6" to accommodate the shear key clamping device.

Detail I - Installation for a new bridge deck or bridge slab.
 Detail II - Installation for a new deck beam with an initial concrete wearing surface. Additional bar splicers shall be provided at 6'-0" centers and paired with the bar splicers of the concrete wearing surface reinforcement to accommodate the installation of the retainer assemblies. The cost of the additional bar splicers is included with the concrete wearing surface.
 Detail III - Installation for a new deck beam with no initial wearing surface or with an initial hot-mix asphalt (HMA) wearing surface present. The deck beam directly beneath the temporary concrete barrier shall be fabricated with bar splicer inserts in the side of the beam, as detailed, to accommodate the installation of the retainer assemblies. A pair of bar splicers, 6" apart, shall be placed at 6'-0" centers along the length of the beam. The cost of the bar splicers is included with the deck beam.

RAILING CRITERIA

NCHRP 350 Test Level	3
Railing Weight (plf)	440

R-27 10-12-2021

PLOT DATE = 8/9/2023
FILE NAME = L:\7660\CADD\Sheets\Bridges\7660-50080-1\B01.dgn

KNIGHT
Engineers & Architects

SCALE	NONE
DATE	8/11/2023

DESIGNED	- KA	REVISED	
CHECKED	- LS	REVISED	
DRAWN	- KA	REVISED	
CHECKED	- LS	REVISED	

STATE OF ILLINOIS
DEPARTMENT OF TRANSPORTATION

TEMPORARY CONCRETE BARRIER
STRUCTURE NUMBER 097-0080 (EB) AND 097-0081 (WB)

SHEET S-12 OF 232 SHEETS

F.A.I. RTE.	SECTION	COUNTY	TOTAL SHEETS	SHEET NO.
64	(97-2) B-5	WHITE	578	196
CONTRACT NO. 78057				
PUBLIC WATERS		ILLINOIS FED. AID PROJECT		

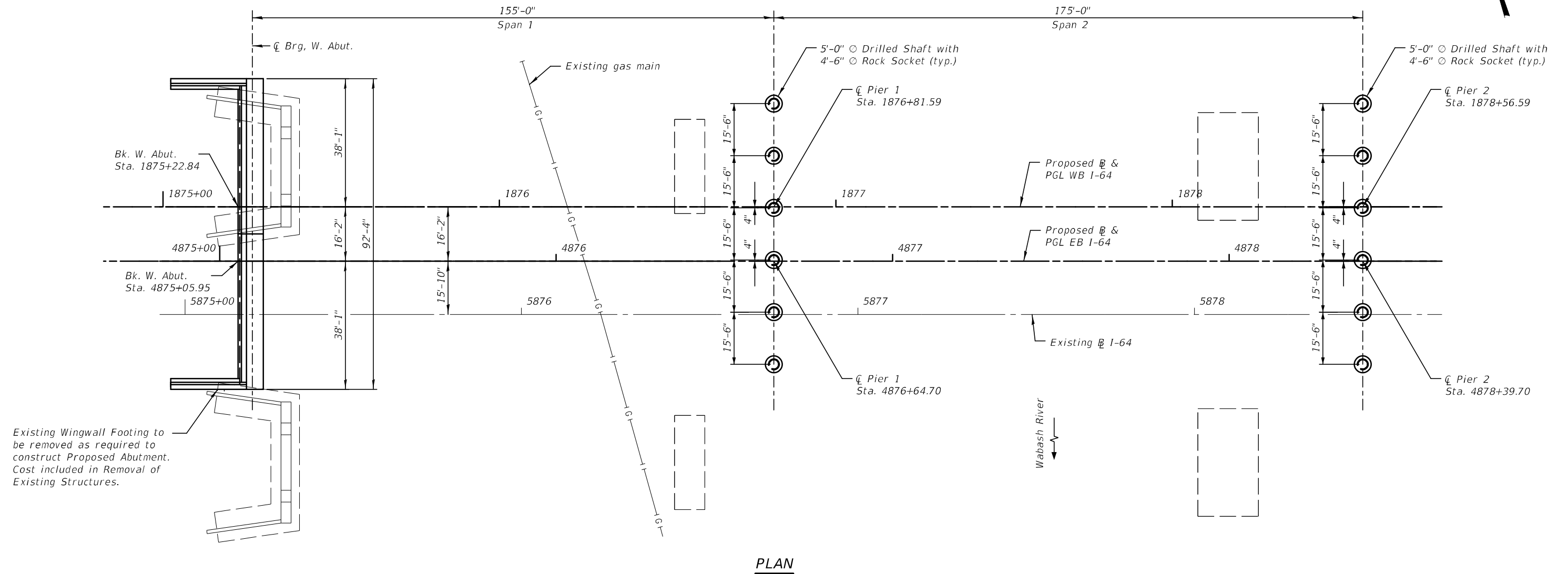

Existing Wingwall Footing to be removed as required to construct Proposed Abutment. Cost included in Removal of Existing Structures.

PLAN

PLOT DATE = 8/9/2023
 FILE NAME = I:\7660\cadd\Sheets\Bridges\7660-50080-HP01.dgn

KNIGHT
Engineers & Architects

DESIGNED - KA	REVISION
CHECKED - LS	REVISION
DRAWN - KA	REVISION
CHECKED - LS	REVISION

STATE OF ILLINOIS
DEPARTMENT OF TRANSPORTATION

SUBSTRUCTURE LAYOUT - SPANS 1 AND 2
STRUCTURE NUMBER 097-0080 (EB) AND 097-0081 (WB)

F.A.I. RTE.	SECTION	COUNTY	TOTAL SHEETS	SHEET NO.
64	(97-2) B-5	WHITE	578	197
CONTRACT NO. 78057				
PUBLIC WATERS		ILLINOIS FED. AID PROJECT		

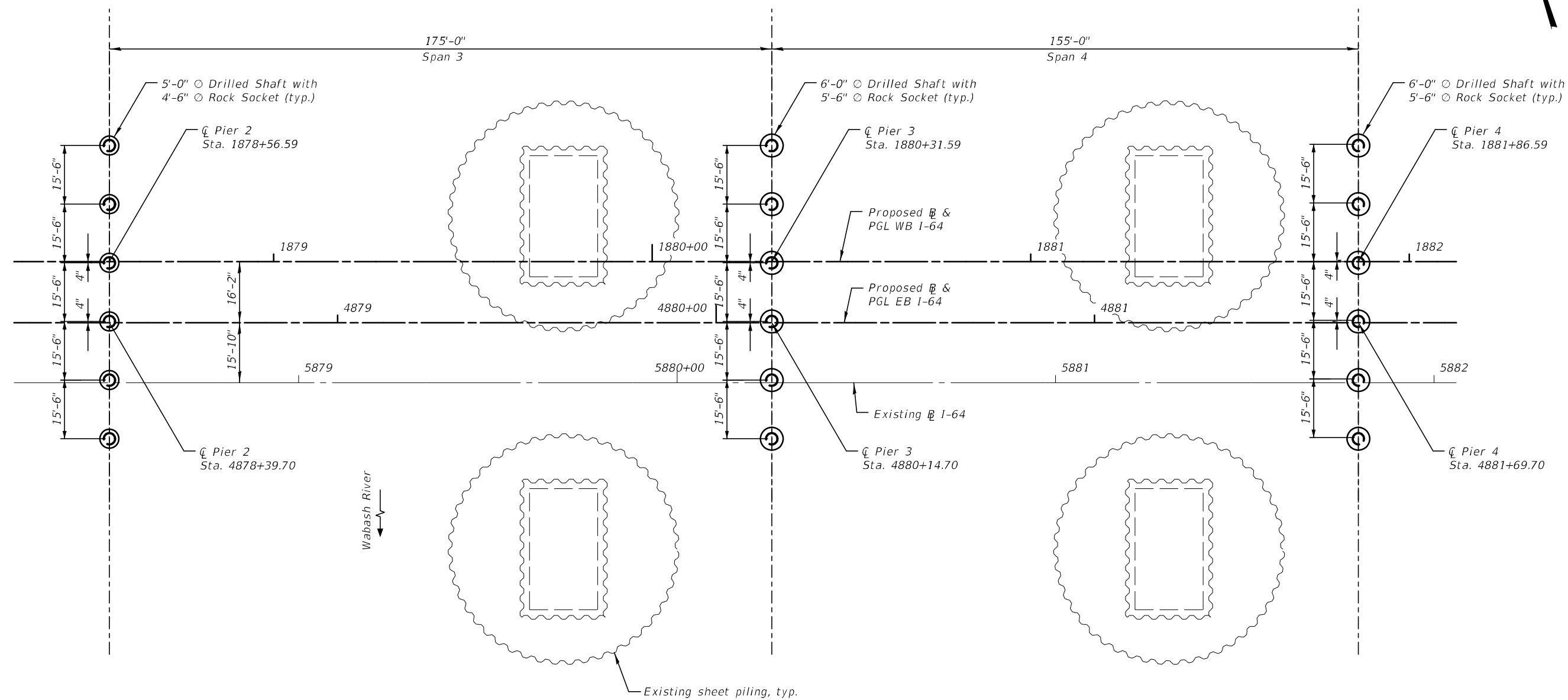

PLAN

PLOT DATE = 8/9/2023
 FILE NAME = I:\7660\cadd\Sheets\Bridges\7660-50080-HP02.dgn

KNIGHT
Engineers & Architects

DESIGNED - KA	REVISED
CHECKED - LS	REVISED
DRAWN - KA	REVISED
CHECKED - LS	REVISED

STATE OF ILLINOIS
DEPARTMENT OF TRANSPORTATION

SUBSTRUCTURE LAYOUT - SPANS 3 AND 4
STRUCTURE NUMBER 097-0080 (EB) AND 097-0081 (WB)

F.A.I. RTE.	SECTION	COUNTY	TOTAL SHEETS	SHEET NO.
64	(97-2) B-5	WHITE	578	198
CONTRACT NO. 78057				
PUBLIC WATERS	ILLINOIS	FED. AID PROJECT		

SHEET S-14 OF 232 SHEETS

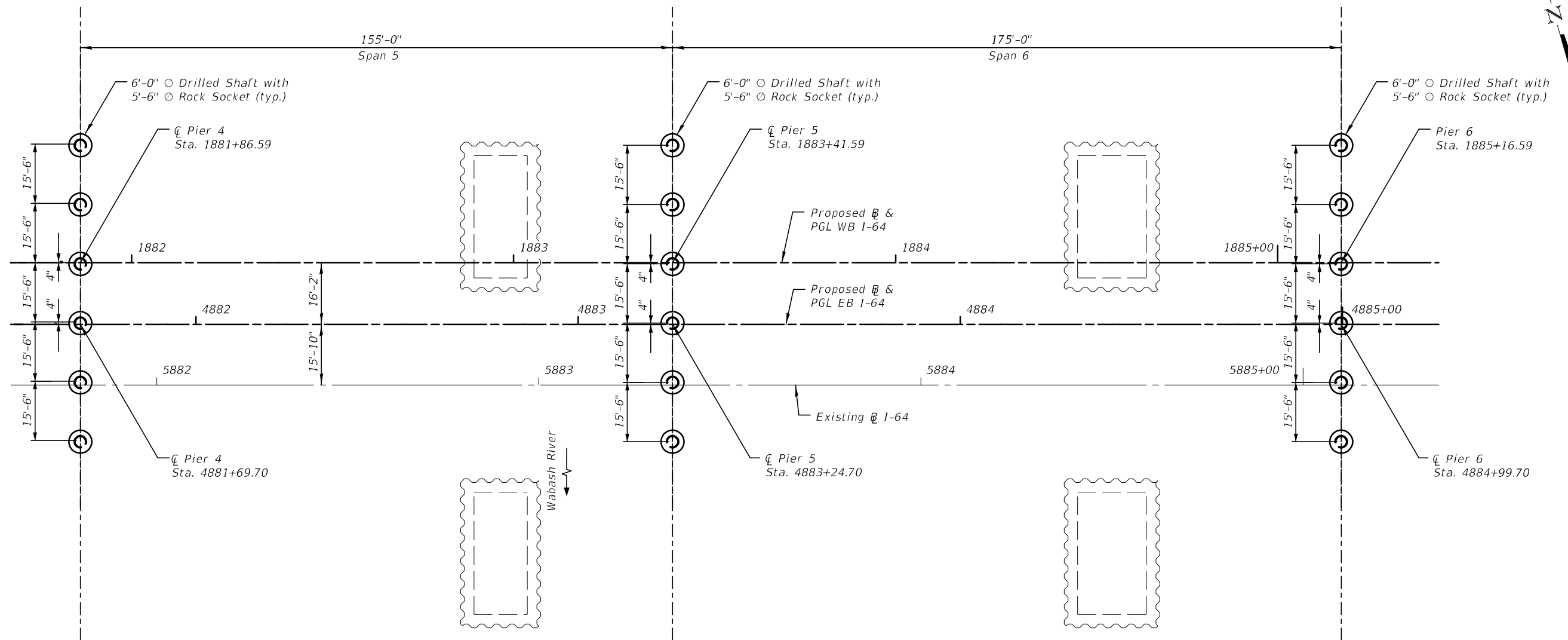

PLAN

PLOT DATE = 8/9/2023
 FILE NAME = I:\7660\cadd\Sheets\Bridges\7660-50080-HP03.dgn



DESIGNED - KA	REVISED
CHECKED - LS	REVISED
DRAWN - KA	REVISED
CHECKED - LS	REVISED
SCALE - NONE	
DATE - 8/11/2023	

STATE OF ILLINOIS
 DEPARTMENT OF TRANSPORTATION

SUBSTRUCTURE LAYOUT - SPANS 5 AND 6
 STRUCTURE NUMBER 097-0080 (EB) AND 097-0081 (WB)

SHEET S-15 OF 232 SHEETS

F.A.I. RTE.	SECTION	COUNTY	TOTAL SHEETS	SHEET NO.
64	(97-2) B-5	WHITE	578	199
CONTRACT NO. 78057				

PUBLIC WATERS ILLINOIS FED. AID PROJECT

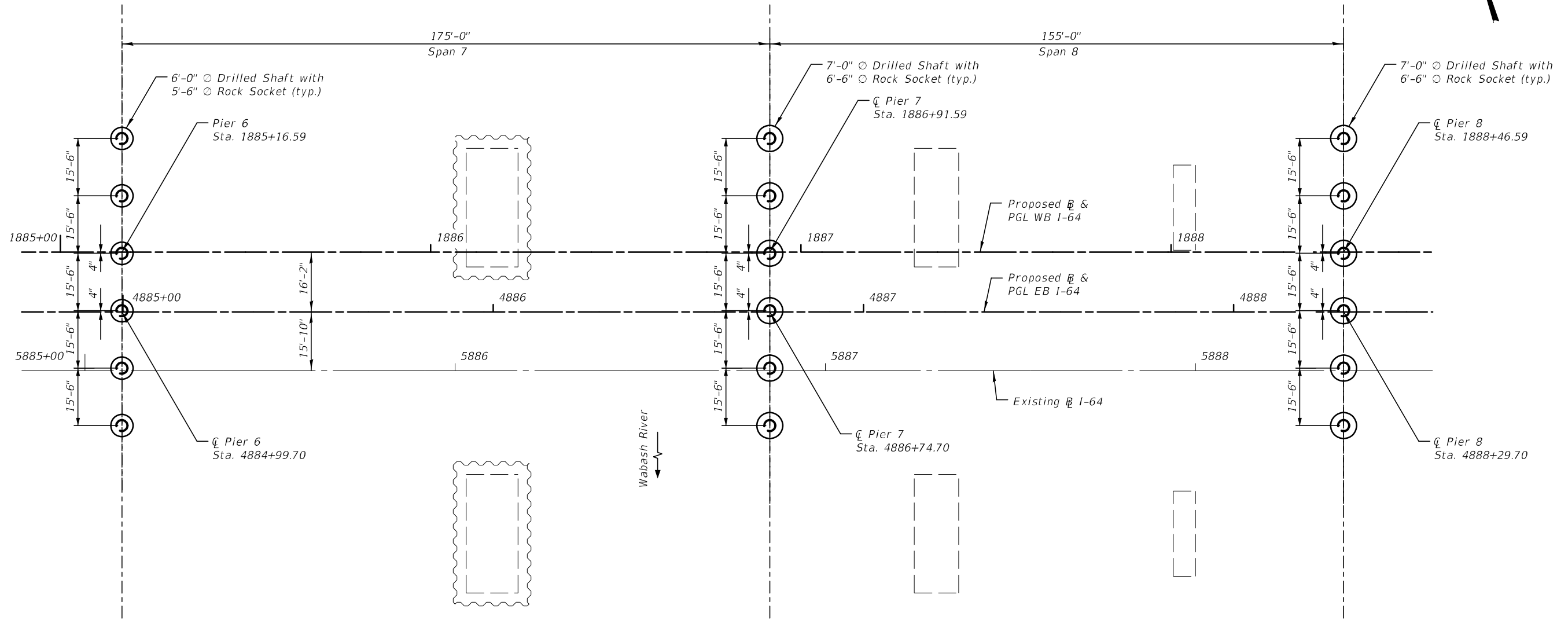

PLAN

PLOT DATE = 8/9/2023
 FILE NAME = I:\7660\cadd\Sheets\Bridges\7660-50080-HP04.dgn

KNIGHT
Engineers & Architects

DESIGNED - KA	REVISED
CHECKED - LS	REVISED
DRAWN - KA	REVISED
CHECKED - LS	REVISED
SCALE - NONE	
DATE - 8/11/2023	

STATE OF ILLINOIS
DEPARTMENT OF TRANSPORTATION

SUBSTRUCTURE LAYOUT - SPANS 7 AND 8
STRUCTURE NUMBER 097-0080 (EB) AND 097-0081 (WB)

F.A.I. RTE.	SECTION	COUNTY	TOTAL SHEETS	SHEET NO.
64	(97-2) B-5	WHITE	578	200
CONTRACT NO. 78057				
PUBLIC WATERS	ILLINOIS	FED. AID PROJECT		

SHEET S-16 OF 232 SHEETS