

P.A. I. SHEET NO.	SECTION	COUNTY	TOTAL SHEETS	SHEET NO.
74	48[(26VB)BY, BY-1]BRR	KNOX	69	1
		CONTRACT NO. 68D83		

INDEX OF SHEETS

- 1. COVER SHEET
- 2. GENERAL NOTES & STATUS OF UTILITIES
- 3. JOB SPECIFIC NOTE & MIX REQUIREMENTS
- 4-9. SUMMARY OF QUANTITIES
- 10-11. SCHEDULE OF QUANTITIES
- 12. LINE DIAGRAM
- 13. TYPICAL SECTIONS
- 14. GENERAL PLAN
- 15-17. STAGING DETAILS
- 18-19. ROADWAY DETAILS
- 20-53. BRIDGE DETAILS
- 54-62. LIGHTING DETAILS
- 63-69. DISTRICT STANDARDS

HIGHWAY STANDARDS

442201-03	701411-09
606001-08	701426-09
630001-13	701428-01
630301-09	701456-05
631031-18	701901-09
701101-05	704001-08
701106-02	780001-05
701400-12	782006-01
701401-13	821001-
701402-12	830021-04
701406-13	838001-01

DESIGN DESIGNATION

INTERSTATE
 ADT (2021): 17,400
 SU (2021): 500
 MU (2021): 3,950

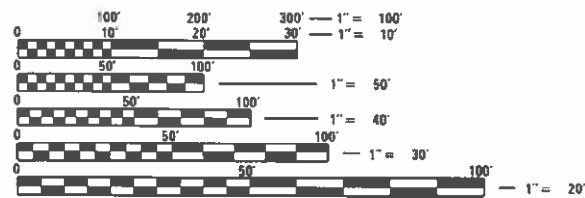

FULL SIZE PLANS HAVE BEEN PREPARED USING STANDARD ENGINEERING SCALES. REDUCED SIZED PLANS WILL NOT CONFORM TO STANDARD SCALES. IN MAKING MEASUREMENTS ON REDUCED PLANS, THE ABOVE SCALES MAY BE USED.

J.U.L.I.E.
 JOINT UTILITY LOCATION INFORMATION FOR EXCAVATORS
 1-800-892-0123
 OR 811

PROJECT ENGINEER & MANAGER:
 ANNA DEVINE 309-671-3475
CATALOG NO. 035507-00D
CONTRACT NO. 68D83

STATE OF ILLINOIS
DEPARTMENT OF TRANSPORTATION

PROPOSED
HIGHWAY PLANS

FAI ROUTE 74 (I-74)
SECTION 48[(26VB)BY, BY-1]BRR
PROJECT NHPP-44SN(770)
BRIDGE PRESERVATION
KNOX COUNTY
C-94-084-17

PROJECT LIMITS
 I-74 OVER BNSF RR IN GALESBURG
 SN 048-0007 & 048-0008

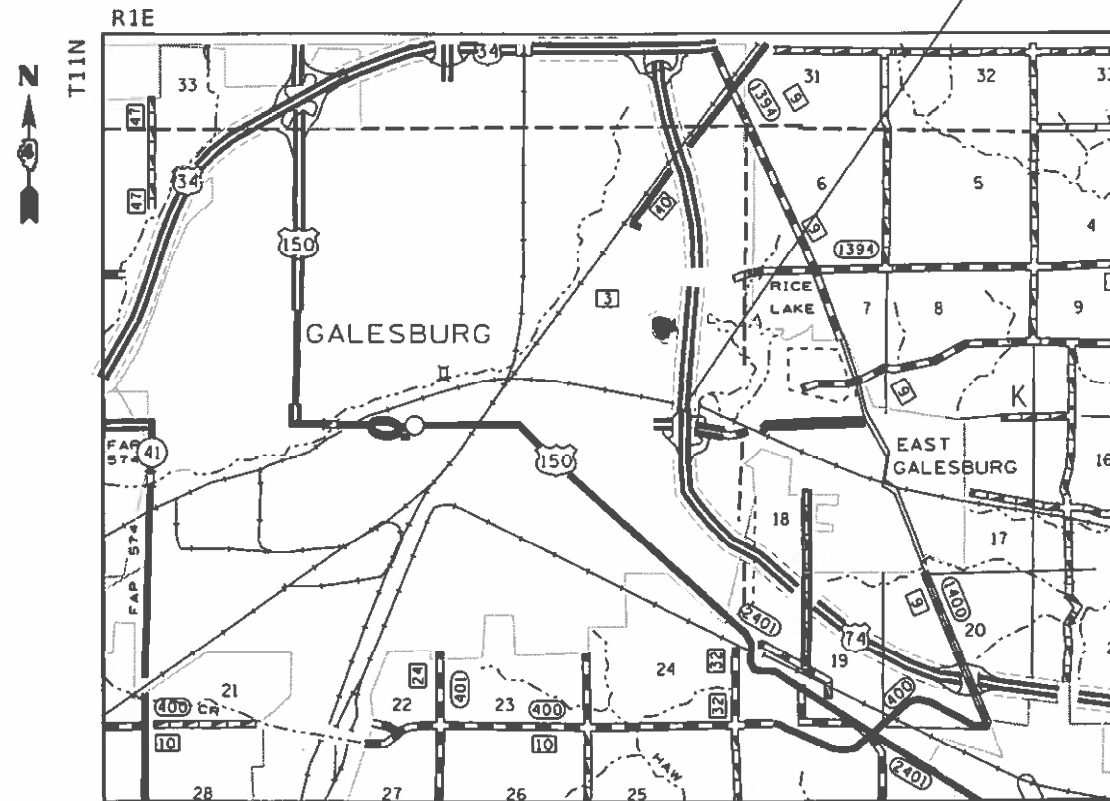

GROSS LENGTH = 997.7 FT. = 0.2 MILE
 NET LENGTH = 997.7 FT. = 0.2 MILE

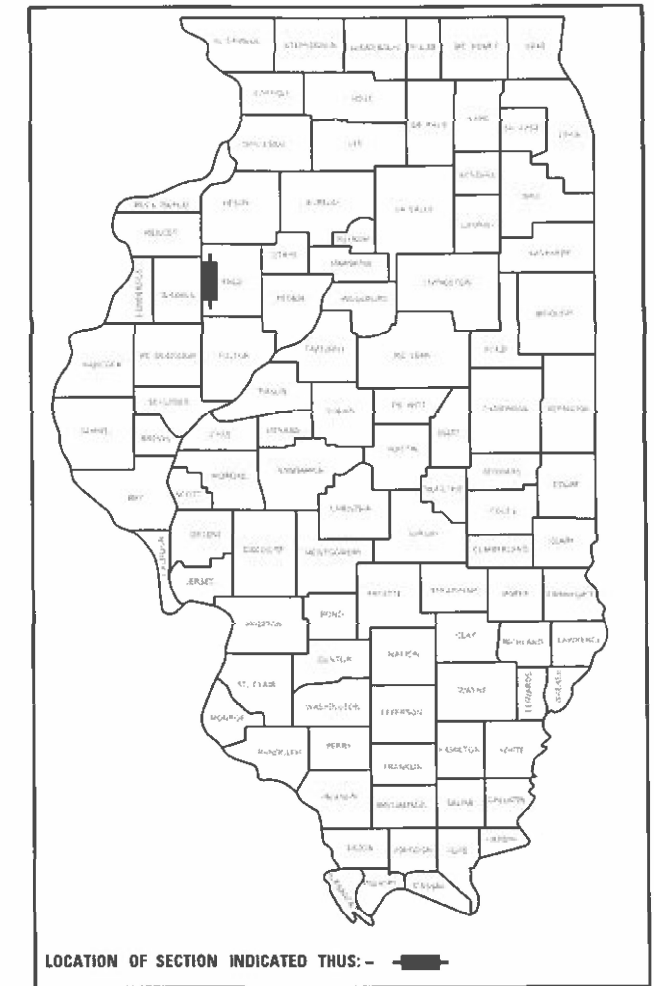

PROJECT DESCRIPTION:
 BRIDGE DECK OVERLAY, BRIDGE JOINT REPLACEMENT, MINOR BRIDGE REPAIRS, AND SLOPEWALL REMOVE & REPLACE TO SN 048-0007 AND SN 048-0008 CARRYING I-74 OVER BNSF RR IN GALESBURG

STATE OF ILLINOIS
 DEPARTMENT OF TRANSPORTATION

SUBMITTED Oct 19 20 23
Ronald A. Barrett RSO
 REGIONAL ENGINEER

December 8, 2023
Steph M. Smith
 ENGINEER OF DESIGN AND ENVIRONMENT

December 8, 2023
Steph M. Smith
 DIRECTOR OF HIGHWAYS PROJECT IMPLEMENTATION

PRINTED BY THE AUTHORITY
OF THE STATE OF ILLINOIS

COMMITMENTS

Commitments are not to be altered without the written approval of all parties to which the commitment was made.

There are no commitments included with this contract.

EARTH EXCAVATION – INCIDENTAL TO CURB, GUTTER, & DRIVEWAY

Earth excavation and backfill for proposed curb and gutters and driveway pavements shall be included in the unit cost of the various items.

ENVIRONMENTAL REVIEWS

Prior to the use of any proposed borrow areas, use areas (temporary access roads, detours, run-arounds, etc.) and/or waste areas, the Contractor shall file the required environmental resource request surveys according to Section 107.22 of the Standard Specifications. These surveys are required in order for the Department to conduct cultural and biological resource surveys for the proposed site.

The required environmental resource documentation shall include the following:

- * BDE Form 2289 (Borrow Site Review)
- * BDE Form 2290 (Waste/Use Area Review)
- * A location map showing the size limits and location of the use area
- * Color photographs depicting the use area
- * Borrow Area Entry Agreement form – D4 PI0101

Prior to any waste materials being removed from the construction site the required environmental resource surveys shall be obtained and filed by the Contractor. Excess waste products removed from the construction site shall be disposed of as required in Section 202.03 of the Standard Specifications.

Any protruding metal bars shall be removed prior to the disposal of broken concrete at approved disposal sites.

Please note that a minimum of four weeks shall be allowed for the District to obtain the required waste site environmental clearances and six weeks for the required borrow site environmental clearances.

BRIDGE OVERLAY NOTIFICATION

After placement of the bridge deck overlay, the Resident Engineer shall notify the District Bridge Maintenance Engineer of the "as constructed" milling depth and overlay thickness for updating the Illinois Highway Information System.

BUTT JOINT CUTTING TIME RESTRICTION

Butt joints shall not be milled more than three (3) days prior to placement of the HMA surface course.

SAW CUT – 18" (450 mm) SHOULDER REMOVAL – IN-PLACE WHEEL SAW GRINDING PERMITTED

A full depth saw cut shall be required at the joint between the pavement that is to be left in place and the existing shoulder that is to be removed. The Contractor may have the option of using a wheel saw to grind up the existing shoulder and leave the finely ground pieces on site under the new shoulder and on the foreslope, with the approval of the Engineer. Maximum size of pieces shall be no more than 3" (75 mm). Larger pieces shall be picked up/removed from the jobsite. No additional compensation will be allowed for variations in assumed thickness. This work shall not be paid for separately, but shall be included in the cost of the removal items.

CROSSING EXISTING STRUCTURES WITH EQUIPMENT

The following structures, SN 048-0007 & SN 048-0008, may be crossed with an empty MTD. If the same MTD is used throughout the entire contract, then it must be limited to an empty gross weight ≤ 40 Tons. Any structures not listed above shall be verified by the resident prior to beginning work.

ADDITIONAL SUPPLEMENTAL TRAFFIC CONTROL

The Department reserves the right at any time to add additional Traffic Control Systems or devices within the active contract limits, by means of an additional contract. All terms of Article 105.08 of the Standard Specifications shall be followed by each Contractor.

POLYMERIZED BITUMINOUS MATERIALS (TACK COAT) RATES

Surface Type	Residual Rate
Milled (HMA or PCC)	0.08 lb /sq ft
Existing Pavement	0.08 lb /sq ft
Fog Coat (between lifts)	0.08 lb /sq ft

68D83 STATUS OF UTILITIES						
Route	Location(s)	Min. Depth	Company	Type of Utility	Type of conflict	Disposition
I-74	Parallel to RR on north side	N/A	Ameren Electric	Aerial Distribution Line & Utility Poles	Equipment	Caution
I-74	Parallel to RR on north side	24"	Comcast	Underground crossing between Ameren Poles	Slope Wall repair and Drainage Improvements	Caution
I-74	Parallel to Interstate on east side along ROW line	24"	IDOT	Fiber	Equipment and Drainage Improvements	Caution

MODEL: Default
 FILE: Mainfile
 PLOT DATE: 10/20/2023
 PROJECT: 68D83
 SHEET: 2 OF 2

USER NAME = \$USERS	DESIGNED -	REVISED -
	DRAWN -	REVISED -
PLOT SCALE = 1:100	CHECKED -	REVISED -
PLOT DATE = 10/20/2023	DATE -	REVISED -

**STATE OF ILLINOIS
DEPARTMENT OF TRANSPORTATION**

GENERAL NOTES & STATUS OF UTILITIES

SCALE: SHEET 1 OF 2 SHEETS STA. TO STA.

F.A.I. RTE.	SECTION	COUNTY	TOTAL SHEETS	SHEET NO.
74	48[(26VB)BY, BY-1]BRR	KNOX	69	2
CONTRACT NO. 68D83				
ILLINOIS FED. AID PROJECT				

JOB SPECIFIC NOTES:

RIGHT-OF-WAY RESTRICTIONS

The Contractor shall be permitted to use the median for parking of paving equipment throughout the project limits. The locations shall be approved by the Resident Engineer and shall provide the following:

1. Any equipment parked in these areas shall be separated from traffic by barrier wall with impact attenuators on approach end of barrier wall or behind guardrail not including any Type 1 Terminals.
2. Storage of equipment shall not encroach upon the paved shoulder or be within 4' of the back of existing guardrail or 2' of temporary barrier wall. Barrier wall must be placed a minimum of 2' from the edge of passing lane.
3. Equipment parking areas shall be located on tangent sections of roadway and not in curves or any location with poor visibility of oncoming traffic.
4. The parking area shall be covered with aggregate to prevent tracking onto the roadway.

When lanes are reopened to traffic, the Contractor shall arrange within a reasonable time period to clean up and restore areas where equipment has been stored to the satisfaction of the Resident Engineer. The disturbed areas shall be seeded using Class 3 seed and covered with Mulch Method 3A or Erosion Control Blanket per Sections 250 and 251 of the Standard Specifications to restore turf to the median.

Any and all material, labor, and equipment costs necessary to comply with these required guidelines shall be included in the cost of project and will not be paid for separately.

The following mixture requirements are applicable for this project:

Location(s):	Mainline	Mainline	Mainline	Shoulders				
Mixture Use(s):	Polymer Surface 1.5"	Polymer Binder 1"	CLASS D PATCH 17"	Surface Lift 2.5"				
AC/PG:	SBS or SBR 70-28	SBS or SBR 70-28	SBS or SBR 70-28	PG 58-28				
Design Air Voids:	4.0% @ N=70	4.0% @ N=50	4.0% @ N=70	4.0% @ N=50				
Mixture Composition: (Mixture Gradation)	IL 9.5	IL 4.75	IL 19.0	IL 9.5				
Friction Aggregate:	Mix E	N.A.	N.A.	Mix C				
Quality Management Program:	QCQA	QCQA	QCQA	QCQA				
MTD:	Yes	Yes	No	No				

Note: 1) Individual lift thickness of each mix type will be no less than 3 times nominal maximum aggregate size and no more than 6 times nominal maximum aggregate size, unless otherwise approved by the Engineer.
 2) For design purposes, mixture weight for all mixes is determined to be 112.0 lb/s.y./in., unless otherwise noted.
 3) Sublot sizes for PFP and QCP mixes will be 1000 tons, unless otherwise agreed to by the Engineer and the paving contractor.

MODEL: Default
 FILE: \\na11e-pw-backend.com\P\DOT\Documents\DOT_offices\Director_4\Project\104_68D83\CADD\3a\C3\Sheet\10468D83-rtb-cover.dgn

USER NAME = \$USERS	DESIGNED -	REVISED -
	DRAWN -	REVISED -
PLOT SCALE = 1:100	CHECKED -	REVISED -
PLOT DATE = 10/20/2023	DATE -	REVISED -

**STATE OF ILLINOIS
DEPARTMENT OF TRANSPORTATION**

JOB SPECIFIC NOTE & MIX REQUIREMENTS

SCALE: SHEET 2 OF 2 SHEETS STA. TO STA.

F.A.I. RTE.	SECTION	COUNTY	TOTAL SHEETS	SHEET NO.
74	48[(26VB)BY,BY-1]BRR	KNOX	69	3
CONTRACT NO. 68D83			ILLINOIS FED. AID PROJECT	

CODE NO.	ITEM	UNIT	TOTAL QUANTITY	CONSTRUCTION CODE		
				90 FED/10 STATE BRIDGE	90 FED/10 STATE BRIDGE	90 FED/10 STATE SAFETY
				0047	0047	0021
				(EB) S.N. 048-0007	(WB) S.N. 048-0008	LIGHTING/GUARDRAIL
20600110	GRANULAR EMBANKMENT, SPEC	TON	498	15	483	
28000400	PERIMETER EROSION BARRIER	FOOT	200	100	100	
28000500	INLET AND PIPE PROTECTION	EACH	1	1		
28100227	STONE RIPRAP, CLASS B4	TON	273	148	125	
28200200	FILTER FABRIC	SQYD	275	150	125	
40600295	POLYMERIZED BITUMINOUS MATERIALS (TACK COAT)	POUND	1871	1034	837	
40600982	HOT-MIX ASPHALT SURFACE REMOVAL- BUTT JOINT	SQYD	1407	782	625	
40600990	TEMPORARY RAMP	SQYD	188	103.5	84.5	
40603200	POLYMERIZED HOT-MIX ASPHALT BINDER COURSE, IL-4.75, N50	TON	45	27	18	
40604172	POLYMERIZED HOT-MIX ASPHALT SURFACE COURSE, IL-9.5, MK "E", N70	TON	89	54	35	
44201855	CLASS D PATCHES, TYPE III, 17 INCH	SQYD	20		20	
44201857	CLASS D PATCHES, TYPE IV, 17 INCH	SQYD	259	161	98	
48101200	AGGREGATE SHOULDERS, TYPE B	TON	14	7	7	
48203100	HOT-MIX ASPHALT SHOULDERS	TON	52	22	30	

MODEL: Default
 FILE NAME: P:\Public\sw Bentley.com\PROJECTS\DOT Office\District 4\Projects\DA 68DB3\CAD\Drawings\CAD\Drawings\DA68DB3-sh-500.dgn

USER NAME = \$USER\$	DESIGNED -	REV[SED] -
	DRAWN -	REV[SED] -
PLOT SCALE = 1:100	CHECKED -	REV[SED] -
PLOT DATE = 10/20/2023	DATE -	REV[SED] -

**STATE OF ILLINOIS
DEPARTMENT OF TRANSPORTATION**

SUMMARY OF QUANTITIES

SCALE: SHEET 1 OF 6 SHEETS STA. TO STA.

F.A.L. RTE. 1	SECTION 48[(26VB) BY, BY-1] BRR	COUNTY KNOX	TOTAL SHEETS 69	SHEET NO. 4
ILLINOIS FED. AID PROJECT			CONTRACT NO. 68DB3	

CODE NO.	ITEM	UNIT	TOTAL QUANTITY	CONSTRUCTION CODE		
				90 FED/10 STATE	90 FED/10 STATE	90 FED/10 STATE
				BRIDGE	BRIDGE	SAFETY
				0047	0047	0021
				(EB) S.N. 048-0007	(WB) S.N. 048-0008	LIGHTING/GUARDRAIL
50102400	CONCRETE REMOVAL	CU YD	23.8	13.2	10.6	
50104650	SLOPE WALL REMOVAL	SQ YD	2409	1218	1191	
50157300	PROTECTIVE SHIELD	SQ YD	658	358	300	
50300255	CONCRETE SUPERSTRUCTURE	CU YD	28.6	15.8	12.8	
50300300	PROTECTIVE COAT	SQ YD	1681	909	772	
50500405	FURNISHING AND ERECTING STRUCTURAL STEEL	POUND	360	360		
50800205	REINFORCEMENT BARS, EPOXY COATED	POUND	3800	2040	1760	
50800515	BAR SPLICERS	EACH	48	24	24	
51100100	SLOPE WALL 4 INCH	SQ YD	2112	1062	1050	
52000110	PREFORMED JOINT STRIP SEAL	FOOT	186	102	84	
59000200	EPOXY CRACK INJECTION	FOOT	92	58	34	
60600605	CONCRETE CURB, TYPE B	FOOT	60			60
* 63000001	STEEL PLATE BEAM GUARDRAIL, TYPE A, 6 FOOT POSTS	FOOT	1037.5			1037.5
* 63100085	TRAFFIC BARRIER TERMINAL, TYPE 6	EACH	4			4

*= SPECIALTY ITEM

MODEL: Default
 FILE: \\na11e1-pw-bentley.com\PW\DOT\Documents\DOT Office\Dir\ref.4\Project\ID_68D83\CADD\31\CAD\Sheet\68D83-ht-500.dgn

USER NAME = \$USER\$	DESIGNED -	REVISED -
	DRAWN -	REVISED -
PLOT SCALE = 1:100	CHECKED -	REVISED -
PLOT DATE = 10/20/2023	DATE -	REVISED -

**STATE OF ILLINOIS
DEPARTMENT OF TRANSPORTATION**

SUMMARY OF QUANTITIES

SCALE: SHEET 2 OF 6 SHEETS STA. TO STA.

F.A.I. RTE.	SECTION	COUNTY	TOTAL SHEETS	SHEET NO.
74	48[(26VB)BY,BY-1]BRR	KNOX	69	5
CONTRACT NO. 68D83			ILLINOIS FED. AID PROJECT	

CODE NO.	ITEM	UNIT	TOTAL QUANTITY	CONSTRUCTION CODE		
				90 FED/10 STATE	90 FED/10 STATE	90 FED/10 STATE
				BRIDGE	BRIDGE	SAFETY
				0047	0047	0021
				(EB) S.N. 048-0007	(WB) S.N. 048-0008	LIGHTING/GUARDRAIL
* 63100167	TRAFFIC BARRIER TERMINAL, TYPE 1 (SPECIAL) TANGENT	EACH	4			4
63200310	GUARDRAIL REMOVAL	FOOT	1451			1451
64200116	SHOULDER RUMBLE STRIPS, 16 INCH	FOOT	449	151	298	
67000400	ENGINEER'S FIELD OFFICE, TYPE A	CAL MO	6	3	3	
67100100	MOBILIZATION	L SUM	1	0.5	0.5	
70100207	TRAFFIC CONTROL AND PROTECTION, STANDARD 701402	EACH	2	1	1	
70100420	TRAFFIC CONTROL AND PROTECTION, STANDARD 701411	EACH	2	1	1	
70100700	TRAFFIC CONTROL AND PROTECTION, STANDARD 701406	L SUM	1			1
70100800	TRAFFIC CONTROL AND PROTECTION, STANDARD 701401	L SUM	1	0.5	0.5	
70100825	TRAFFIC CONTROL AND PROTECTION, STANDARD 701456	L SUM	1			1
70107005	PAVEMENT MARKING BLACKOUT TAPE, 5"	FOOT	3250	1125	2125	
70107007	PAVEMENT MARKING BLACKOUT TAPE, 7"	FOOT	840	600	240	
70107025	CHANGEABLE MESSAGE SIGN	CAL DA	21	10.5	10.5	
70300150	SHORT TERM PAVEMENT MARKING REMOVAL	SQ FT	1844	819	1025	

* = SPECIALTY ITEM

MODEL: Default
 FILE: \\na11fz-pw-bentley.com\P\DOT\Documents\DOT Office\Dir\ref.4\Project\104_68083\CADD\31\CAD\Sheet\10468083-ht-500.dgn

USER NAME = \$USER\$	DESIGNED -	REVISED -
	DRAWN -	REVISED -
PLOT SCALE = 1:100	CHECKED -	REVISED -
PLOT DATE = 10/20/2023	DATE -	REVISED -

**STATE OF ILLINOIS
DEPARTMENT OF TRANSPORTATION**

SUMMARY OF QUANTITIES

SCALE: SHEET 3 OF 6 SHEETS STA. TO STA.

F.A.I. RTE.	SECTION	COUNTY	TOTAL SHEETS	SHEET NO.
74	48[(26VB)BY, BY-1]BRR	KNOX	69	6
CONTRACT NO. 68D83			ILLINOIS FED. AID PROJECT	

					CONSTRUCTION CODE		
CODE NO.	ITEM	UNIT	TOTAL QUANTITY	90 FED/10 STATE	90 FED/10 STATE	90 FED/10 STATE	
				BRIDGE	BRIDGE	SAFETY	
				0047	0047	0021	
				(EB) S.N. 048-0007	(WB) S.N. 048-0008	LIGHTING/GUARDRAIL	
70400100	TEMPORARY CONCRETE BARRIER	FOOT	1025	512.5	512.5		
70400200	RELOCATE TEMPORARY CONCRETE BARRIER	FOOT	1025	512.5	512.5		
70600250	IMPACT ATTENUATORS, TEMPORARY (NON- REDIRECTIVE), TEST LEVEL 3	EACH	2	1	1		
70600350	IMPACT ATTENUATORS, RELOCATE (NON- REDIRECTIVE), TEST LEVEL 3	EACH	2	1	1		
* 72501000	TERMINAL MARKER - DIRECT APPLIED	EACH	4			4	
* 78009006	MODIFIED URETHANE PAVEMENT MARKING - LINE 6"	FOOT	3150	1630	1520		
* 78009008	MODIFIED URETHANE PAVEMENT MARKING - LINE 8"	FOOT	806	542	264		
* 78009012	MODIFIED URETHANE PAVEMENT MARKING - LINE 12"	FOOT	82	82			
* 78011035	GROOVING FOR RECESSED PAVEMENT MARKING 7"	FOOT	3150	1630	1520		
* 78011045	GROOVING FOR RECESSED PAVEMENT MARKING 9"	FOOT	806	542	264		
* 78011065	GROOVING FOR RECESSED PAVEMENT MARKING 13"	FOOT	82	82			
* 7812000	RAISED REFLECTIVE PAVEMENT MARKER (BRIDGE)	EACH	14	10	4		
* 78200011	BARRIER WALL REFLECTORS, TYPE C	EACH	36	18	18		
78300200	RAISED REFLECTIVE PAVEMENT MARKER REMOVAL	EACH	14	10	4		

*= SPECIALTY ITEM

MODEL: Default
FILE NAME: p:\idirect-pw-bentley.com\p\idirect-pw\documents\DOT_offices\dir\dir_4\Project\ID_68D83\CADD\Drawings\CAD\Drawings\68D83-ht-500.dgn

USER NAME = \$USERS	DESIGNED -	REVISED -
	DRAWN -	REVISED -
PLOT SCALE = 1:100	CHECKED -	REVISED -
PLOT DATE = 10/20/2023	DATE -	REVISED -

**STATE OF ILLINOIS
DEPARTMENT OF TRANSPORTATION**

SUMMARY OF QUANTITIES

SCALE: SHEET 4 OF 6 SHEETS STA. TO STA.

F.A.I. RTE.	SECTION	COUNTY	TOTAL SHEETS	SHEET NO.
74	48[(26VB)BY, BY-1]BRR	KNOX	69	7
			CONTRACT NO. 68D83	
		ILLINOIS FED. AID PROJECT		

CODE NO.	ITEM	UNIT	TOTAL QUANTITY	CONSTRUCTION CODE		
				90 FED/10 STATE	90 FED/10 STATE	90 FED/10 STATE
				BRIDGE	BRIDGE	SAFETY
				0047	0047	0021
				(EB) S.N. 048-0007	(WB) S.N. 048-0008	LIGHTING/GUARDRAIL
* 82110008	LUMINAIRE, LED, ROADWAY, OUTPUT DESIGNATION H	EACH	25			25
* 82500330	LIGHTING CONTROLLER, PEDESTAL MOUNTED, 240VOLT, 60AMP	EACH	1			1
* 83060830	LIGHT POLE, GALVANIZED STEEL, 45 FT. MH., TENON MOUNT	EACH	4			4
* 83800650	BREAKAWAY DEVICE, COUPLING WITH STAINLESS STEEL SCREEN	EACH	16			16
* X0320023	CLOSED CIRCUIT TELEVISION DOME CAMERA, HD	EACH	1			1
X4400196	HOT-MIX ASPHALT SURFACE REMOVAL (SPECIAL)	SQ YD	58	33.5	24.5	
X5015225	PIPE CULVERT REMOVAL (SPECIAL)	FOOT	80	40	40	
X5030250	BRIDGE DECK GROOVING (LONGITUDINAL)	SQ YD	1553	925	628	
X6050310	FILLING INLETS (SPECIAL)	EACH	2	1	1	
X6350204	LINEAR DELINEATOR PANELS, 4 INCH	EACH	15			15
X6650208	WOVEN WIRE FENCE REMOVAL AND REPLACEMENT	FOOT	356	178	178	
* X8210402	LUMINAIRE MOUNTING BRACKET (SPECIAL)	EACH	21			21
Z0001002	GUARDRAIL AGGREGATE EROSION CONTROL	TON	4			4
Z0001903	STRUCTURAL STEEL REMOVAL	POUND	280	280		

*= SPECIALTY ITEM

MODEL: Default
 FILE: \\na11fz-pw-bentley.com\PW\DOT\Documents\DOT Office\Dir\ref.4\Project\ID_68D83\CADD\Drawings\CAD\Sheet\DA68D83-ht-500.dgn

USER NAME = \$USER\$	DESIGNED -	REVISED -
	DRAWN -	REVISED -
PLOT SCALE = 1:100	CHECKED -	REVISED -
PLOT DATE = 10/20/2023	DATE -	REVISED -

**STATE OF ILLINOIS
DEPARTMENT OF TRANSPORTATION**

SUMMARY OF QUANTITIES

SCALE: SHEET 5 OF 6 SHEETS STA. TO STA.

F.A.I. RTE.	SECTION	COUNTY	TOTAL SHEETS	SHEET NO.
74	48[(26VB)BY,BY-1]BRR	KNOX	69	8
ILLINOIS FED. AID PROJECT			CONTRACT NO. 68D83	

CODE NO.	ITEM	UNIT	TOTAL QUANTITY	CONSTRUCTION CODE		
				90 FED/10 STATE	90 FED/10 STATE	90 FED/10 STATE
				BRIDGE	BRIDGE	SAFETY
				0047	0047	0021
				(EB) S.N. 048-0007	(WB) S.N. 048-0008	LIGHTING/GUARDRAIL
Z0001905	STRUCTURAL STEEL REPAIR	POUND	210	210		
Z0012130	BRIDGE DECK SCARIFICATION 3/4"	SQ YD	2113	1146	967	
Z0012164	BRIDGE DECK MICROSILICA CONCRETE OVERLAY 2 1/2"	SQ YD	2113	1146	967	
Z0012754	STRUCTURAL REPAIR OF CONCRETE (DEPTH EQUAL TO OR LESS THAN 5 INCHES)	SQ FT	9	6	3	
Z0018001	DECK SLAB REPAIR (FULL DEPTH, TYPE I)	SQ YD	48.8	26.5	22.3	
Z0018051	DRAINAGE SCUPPERS TO BE ADJUSTED	EACH	8	4	4	
Z0025615	FURNISH AND INSTALL METAL SCREEN	EACH	14			14
Z0029090	DIAMOND GRINDING (BRIDGE SECTION)	SQ YD	2415	1324	1091	
∅ Z0076600	TRAINEES	hour	2,000	2,000		
Z0034105	MATERIAL TRANSFER DEVICE	TON	134	81	53	
∅ Z0076604	TRAINEES - TRAINING PROGRAM GRADUATE	hour	2,000	2,000		
Z0048665	RAILROAD PROTECTIVE LIABILITY INSURANCE	L SUM	1	0.5	0.5	

∅ 0042

MODEL: Default
FILE: \\na11f01.pva\ultra-cw-beam\pva.com\PIV\DOT\Documents\DOT Office\Dir\rdt_4\Project\ID_68D83\CADD\Drawn\CAD\Sheet\ID_68D83-ht-500.dgn

USER NAME = \$USER\$	DESIGNED -	REVISED -
	DRAWN -	REVISED -
PLOT SCALE = 1:100	CHECKED -	REVISED -
PLOT DATE = 10/20/2023	DATE -	REVISED -

**STATE OF ILLINOIS
DEPARTMENT OF TRANSPORTATION**

SUMMARY OF QUANTITIES

SCALE: SHEET 6 OF 6 SHEETS STA. TO STA.

F.A.I. RTE.	SECTION	COUNTY	TOTAL SHEETS	SHEET NO.
74	48[(26VB)BY, BY-1]BRR	KNOX	69	9
CONTRACT NO. 68D83				
ILLINOIS FED. AID PROJECT				

PAVEMENT SCHEDULE

LOCATION	LENGTH	DL & PL WIDTH	RAMP LANE	INSIDE SHLDR WIDTH	OUTSIDE SHLDR WIDTH	CLASS D PATCHES, 17"*		HMA SURFACE REMOVAL - BUTT JOINT	TEMPORARY RAMP	POLY. HMA SURFACE COURSE, IL-9.5, MIX "E", N70		HMA SURFACE REMOVAL (SPECIAL)	POLY. HMA BINDER COURSE, IL-4.75, N50	HMA SHOULDERS	POLY. BIT. MATERIALS (TACK COAT)	MATERIAL TRANSFER DEVICE	AGGREGATE SHOULDERS, TYPE B	SHOULDER RUMBLE STRIPS, 16 INCH							
						TYPE III	TYPE IV			1.5"	6" wide joint trim								JOINT TRIM	1"	0.08 LB/SQ FT				
						SQ. YD.	SQ. YD.			TON	TON								SQ. YD.	TON	TON	POUND	TON	TON	FOOT
EASTBOUND I-74 (SN 048-0007)																									
STA	337+21.5	TO	337+81.5	60.0	24.0	12.0	4.0	6.0			306.7	51.1	20.2	1.1	13.3	13.4	9.3	451.2	34.7		82.0				
STA	337+81.5	TO	337+98.5	VAR	24.0	12.0	5.0	6.5		79.4	79.1		5.1	0.3	3.4		1.5	59.4	5.4						
STA	337+98.5	TO	340+31.8	233.3																					
STA	340+31.8	TO	340+45.1	VAR	24.0	12.0	5.0	6.5		81.4	81.4		5.1	0.3	3.4		1.7	61.0	5.4		69.0				
STA	340+45.1	TO	341+05.1	60.0	24.0	13.2	4.0	6.0			314.5	52.4	20.8	1.1	13.3	13.9	9.3	462.4	35.8		7.1				
WESTBOUND I-74 (SN 048-0008)																									
STA	337+48.2	TO	338+08.2	60.0	24.0		4.0	10.0			253.3	42.2	13.4	0.8	10.0	9.0	13.1	374.3	23.2		149.0				
STA	338+08.2	TO	338+21.7	VAR	24.0		5.0	10.6		62.8	62.8		3.0	0.2	2.2		2.3	46.8	3.2						
STA	338+21.7	TO	340+59.2	237.5	24.0																				
STA	340+59.2	TO	340+72.6	VAR	24.0		5.0	10.6		19.8	35.6		3.0	0.2	2.2		1.7	41.6	3.2		149.0				
STA	340+72.6	TO	341+32.6	60.0	24.0		4.0	10.0			253.3	42.2	13.4	0.8	10.0	9.0	13.1	374.4	23.2						
<i>EB (SN 048-0007) TOTAL</i>										0.0	161.0		782.0	103.5		54.0		33.5	27.0		22.0	1034.0	81.0	7.0	151.0
<i>WB (SN 048-0008) TOTAL</i>										20.0	98.0		625.0	84.5		35.0		30.0	18.0		30.0	837.0	53.0	7.0	298.0
GRAND TOTAL										20.0	259.0		1407.0	188.0		89.0		58.0	45.0		52.0	1871.0	134.0	14.0	449.0

*REMOVAL OF THE EXISTING PAVEMENT CONNECTOR AND REPLACEMENT WITH CLASS D PATCHES SHALL BE PAID FOR AS "CLASS D PATCHES, TYPE III AND IV 17 INCH"

DRAINAGE TABLE

LOCATION	PIPE CULVERT REMOVAL (SPECIAL)	FILTER FABRIC	STONE RIPRAP, CLASS B4	FILLING INLETS, SPECIAL	WOVEN WIRE FENCE REMOVAL & REPLACEMENT	PERIMETER EROSION BARRIER	INLET AND PIPE PROTECT
EB I-74 (SN 048-0007)							
RT	STA	337+98.7	40.0	35.1	23.4	1.0	130.0
		MEDIAN				48.0	1.0
		BY SLOPEWALL				100.0	
		TOTAL FROM BILL OF MATERIAL		150.0	148.0		
WB I-74 (SN 048-0008)							
LT	STA	338+37.9	40.0	35.1	23.4	1.0	130.0
		MEDIAN				48.0	
		BY SLOPEWALL				100.0	
		TOTAL FROM BILL OF MATERIAL		125.0	125.0		
		<i>EB (SN 048-0007) TOTAL</i>	40.0	185.0	171.5	1.0	178.0
		<i>WB (SN 048-0008) TOTAL</i>	40.0	160.0	148.5	1.0	178.0
		GRAND TOTAL	80.0	345.0	320.0	2.0	356.0

PAVEMENT MARKING TABLE

LOCATION	MODIFIED URETHANE PAVEMENT MARKING - LINE 6"			GROOVING FOR RECESSED PAVEMENT MARKING 7"	MODIFIED URETHANE PAVEMENT MARKING - LINE 8"		GROOVING FOR RECESSED PAVEMENT MARKING 9"	MODIFIED URETHANE PAVEMENT MARKING - LINE 12"	GROOVING FOR RECESSED PAVEMENT MARKING 13"	RAISED REFLECTIVE PAVEMENT MARKER (BRIDGE)	RAISED REFLECTIVE PAVEMENT MARKER REMOVAL			
	WHITE SOLID	YELLOW SOLID	WHITE CL SKIP		DASH	GORE								
	FOOT	FOOT	FOOT		FOOT	FOOT								
EASTBOUND I-74														
STA	334+50.0	TO	341+75.0	725.0	725.0	180.0	1630.0	180.0	362.0	542.0	82.0	82.0	10.0	10.0
WESTBOUND I-74														
STA	337+25.0	TO	344+00.0	675.0	675.0	170.0	1520.0		264.0	264.0			4.0	4.0
		<i>EB (SN 048-0007) TOTAL</i>		1630.0		1630.0	180.0	362.0	542.0	82.0	82.0	10.0	10.0	
		<i>WB (SN 048-0008) TOTAL</i>		1520.0		1520.0	0.0	264.0	264.0	0.0	0.0	4.0	4.0	
		GRAND TOTAL		3150.0		3150.0	806.0	806.0	82.0	82.0	14.0	14.0		

MODEL: Default
FILE NAME: p:\projects\paw_beaufay.com\p\INDOT\Documents\INDOT_offices\Director_d\Project\104_68083\CADD\Drawings\048\048083-sch-schedule.dgn

USER NAME = SUSERS	DESIGNED -	REVISED -
	DRAWN -	REVISED -
PLOT SCALE = 1:100	CHECKED -	REVISED -
PLOT DATE = 10/20/2023	DATE -	REVISED -

**STATE OF ILLINOIS
DEPARTMENT OF TRANSPORTATION**

SCHEDULE OF QUANTITIES

SCALE: SHEET 1 OF 2 SHEETS STA. TO STA.

F.A.I. RTE.	SECTION	COUNTY	TOTAL SHEETS	SHEET NO.
74	48(126VB)BY-BY-1)BRR	KNOX	69	10
CONTRACT NO. 68D83				
ILLINOIS FED. AID PROJECT				

GUARDRAIL TABLE											
LOCATION	LENGTH OF NEED STATION			GUARDRAIL REMOVAL	TRAFFIC BARRIER TERMINAL, TYPE 1 (SPECIAL) TANGENT	SPBGR TYPE A 6 FT POSTS	TRAFFIC BARRIER TERMINAL, TYPE 6	CONCRETE CURB, TYPE B	LINEAR DELINEATOR PANELS, 4"	TERMINAL MARKER - DIRECT APPLIED	GUARDRAIL AGGREGATE EROSION CONTROL
	STA.	FOOT	TON								
EASTBOUND (SN 048-0007)											
RT	STA	334+70.8	TO 335+20.8	335+31.0	332.0	1.0	250.0	4.0	1.0	1.0	
	STA	335+20.8	TO 337+70.8								
	STA	337+70.8	TO 338+07.7								
LT.	STA	334+45.4	TO 334+95.4	334+68.9	419.0	1.0	287.5	4.0	1.0	1.0	
	STA	334+95.4	TO 337+82.9								
	STA	337+82.9	TO 338+20.4								
WESTBOUND (SN 048-0008)											
RT	STA	340+38.5	TO 340+75.4	343+98.1	400.0	1.0	287.5	4.0	1.0	1.0	
	STA	340+75.4	TO 343+62.9								
	STA	343+62.9	TO 344+12.9								
LT.	STA	340+43.7	TO 340+80.6	343+20.4	300.0	1.0	212.5	3.0	1.0	1.0	
	STA	340+80.6	TO 342+93.1								
	STA	342+93.1	TO 343+43.1								
EB (SN 048-0007) TOTAL				751.0	2.0	537.5	2.0	30.0	8.0	2.0	2.0
WB (SN 048-0008) TOTAL				700.0	2.0	500.0	2.0	30.0	7.0	2.0	2.0
GRAND TOTAL				1451.0	4.0	1037.5	4.0	60.0	15.0	4.0	4.0

JOBSITE TABLE									
LOCATION	MOBILIZATION	ENGINEER'S FIELD OFFICE, TYPE A	CHANGEABLE MESSAGE SIGN*	TRAFFIC CONTROL AND PROTECTION, STANDARD 701456	TRAFFIC CONTROL AND PROTECTION, STANDARD 701401	TRAFFIC CONTROL AND PROTECTION, STANDARD 701402	TRAFFIC CONTROL AND PROTECTION, STANDARD 701406	TRAFFIC CONTROL AND PROTECTION, STANDARD 701411	BARRIER WALL REFLECTORS, TYPE C
				LSUM	CAL MO	CAL DAY	LSUM	LSUM	EACH
EASTBOUND (SN 048-0007)	0.5	3.0	10.5		0.5	1.0		1.0	18.0
WESTBOUND (SN 048-0008)	0.5	3.0	10.5		0.5	1.0		1.0	18.0
LIGHTING				1.0			1.0		
TOTAL	1.0	6.0	21.0	1.0	1.0	2.0	1.0	2.0	36.0

* 3 BOARDS FOR 7 DAYS EACH

STAGING TABLE									
LOCATION	TEMPORARY CONCRETE BARRIER	RELOCATE TEMPORARY CONCRETE BARRIER	IMPACT ATTENUATORS, TEMPORARY (NON-REDIRECTIVE), TEST LEVEL 3	IMPACT ATTENUATORS, RELOCATE (NON-REDIRECTIVE), TEST LEVEL 3	PAVEMENT MARKING BLACKOUT TAPE, 5"	PAVEMENT MARKING BLACKOUT TAPE, 7"	SHORT TERM PAVEMENT MARKING REMOVAL		
	FOOT	FOOT	EACH	EACH	FOOT	FOOT	SQ FT		
I-74 EASTBOUND (SN 048-0007)									
STA	335+34.0	TO 341+09.0	512.5	512.5	1.0	1.0	1125.0	600.0	818.8
I-74 WESTBOUND (SN 048-0008)									
STA	337+45.0	TO 343+32.0	512.5	512.5	1.0	1.0	2125.0	240.0	1025.4
EB (SN 048-0007) TOTAL			512.5	512.5	1.0	1.0	1125.0	600.0	819.0
WB (SN 048-0008) TOTAL			512.5	512.5	1.0	1.0	2125.0	240.0	1025.0
GRAND TOTAL			1025.0	1025.0	2.0	2.0	3250.0	840.0	1844.0

MODEL: Default
 FILE: \\na11f01-pw-bentley.com\PWDOT\Documents\DOT Office\Dir\dir.ctb\Project\I-74_68DB3\CADD\Drawings\Civil\Sheet\I-74-68DB3-ctb-sched.tbl.dgn

USER NAME = \$USERS	DESIGNED -	REVISED -
	DRAWN -	REVISED -
PLOT SCALE = 1:100	CHECKED -	REVISED -
PLOT DATE = 10/20/2023	DATE -	REVISED -

**STATE OF ILLINOIS
DEPARTMENT OF TRANSPORTATION**

SCHEDULE OF QUANTITIES			
SCALE:	SHEET 2	OF 2	SHEETS
STA.	TO STA.		

F.A.I. RTE.	SECTION	COUNTY	TOTAL SHEETS	SHEET NO.
74	48(126VB)BY, BY-1)BRR	KNOX	69	11
CONTRACT NO. 68DB3				
ILLINOIS FED. AID PROJECT				

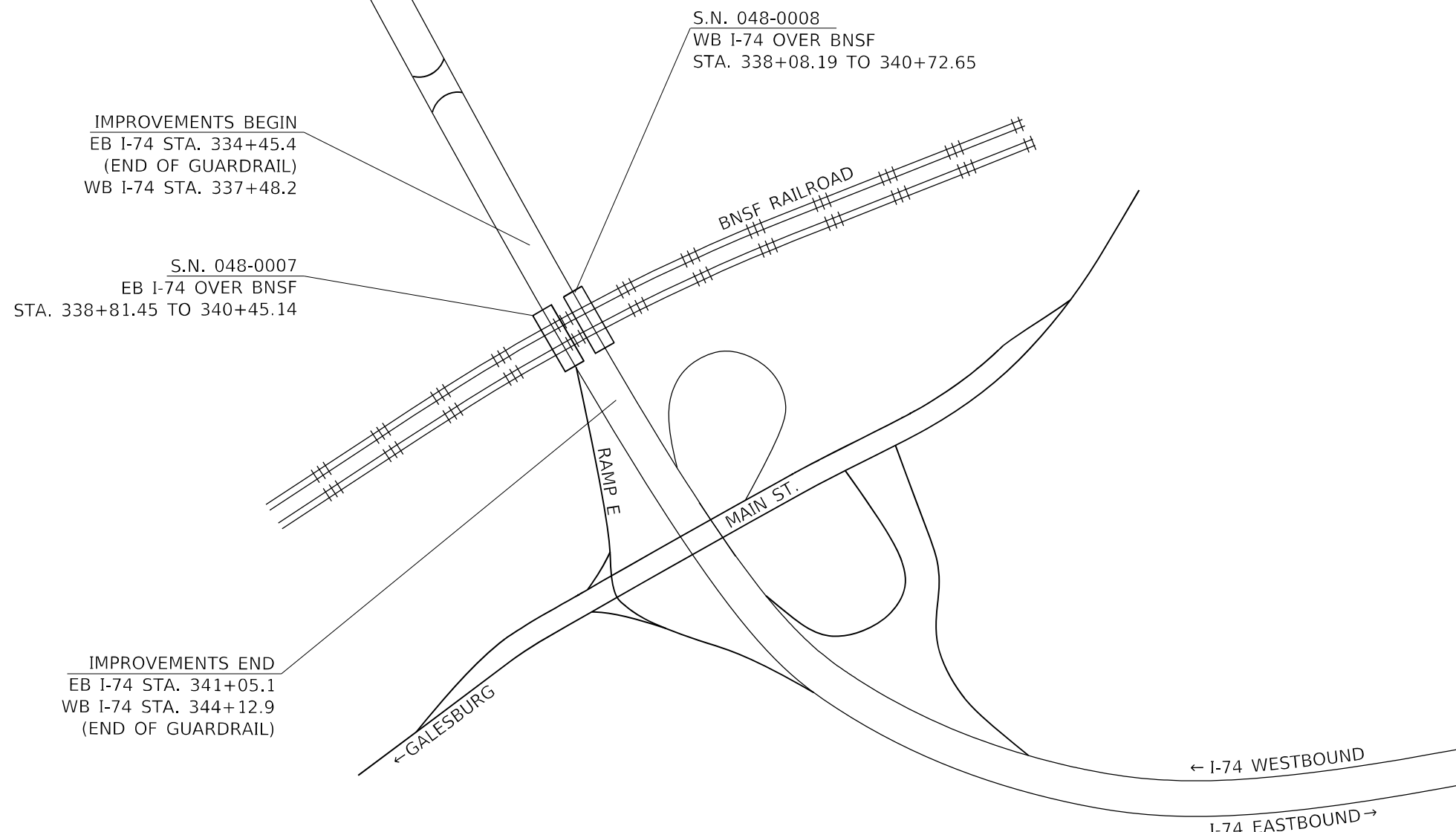
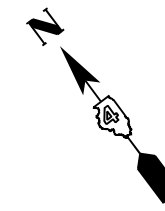

MODEL: Default
 FILE NAME: p:\ultra-cw-beadley.com\PIV\DOT\Documents\DOT Offices\Dir\rdt_4\Project\ID4_68D83\CADD\Drawings\CAD\Sheet\DA68D83-ht-cover.dgn

USER NAME = \$USERS	DESIGNED -	REVISED -
	DRAWN -	REVISED -
PLOT SCALE = 1:100	CHECKED -	REVISED -
PLOT DATE = 10/20/2023	DATE -	REVISED -

STATE OF ILLINOIS
DEPARTMENT OF TRANSPORTATION

LINE DIAGRAM			
SCALE:	SHEET 1	OF 1 SHEETS	STA. TO STA.

F.A.I. RTE.	SECTION	COUNTY	TOTAL SHEETS	SHEET NO.
74	48[(26VB)BY,8Y-1]BR	KNOX	69	12
CONTRACT NO. 68D83				
ILLINOIS FED. AID PROJECT				

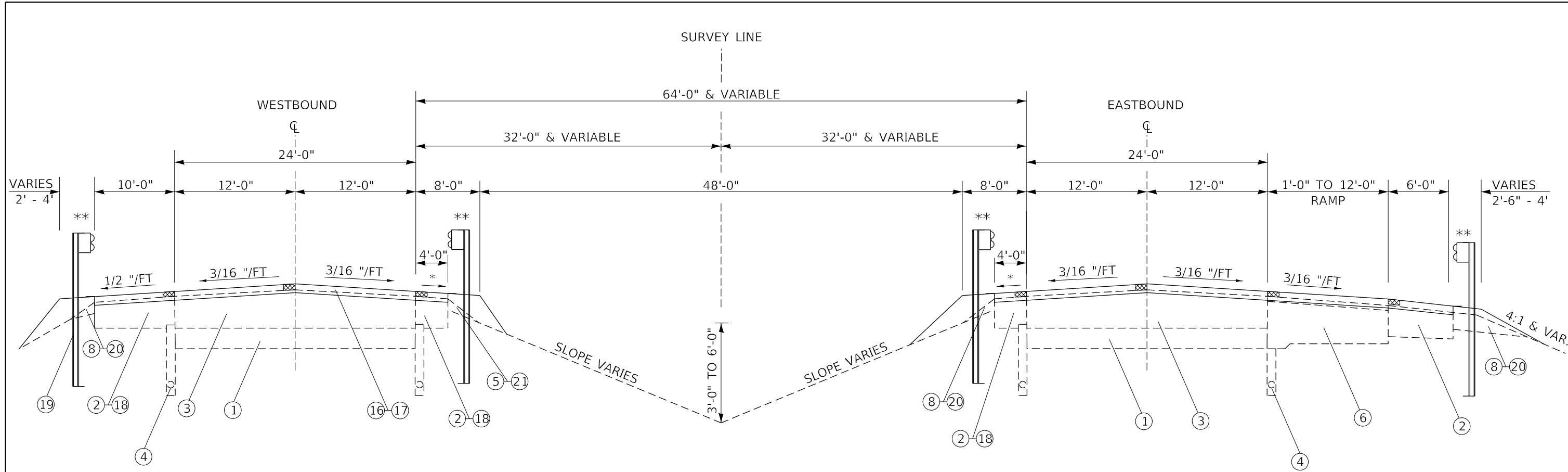

STA. 334+45.4 TO STA. 341+32.7
 BRIDGE OMISSION W.B: STA. 338+08.19 TO STA. 340+72.65
 BRIDGE OMISSION E.B: STA. 337+81.45 TO STA. 340+45.14

JOINT TRIMMING - 6" WIDE
 (SEE SCHEDULES AND HMA SURF. REMOVAL (SPECIAL) SPECIAL PROVISION)

LEGEND	
EXISTING ITEMS	PROPOSED ITEMS
① PCC PAVEMENT, 7" TO 10"	①⑥ HMA SURFACE, 1 1/2"
② BITUMINOUS SHOULDER	①⑦ HMA BINDER, 1"
③ BITUMINOUS OVERLAY, 11 1/2"	①⑧ HMA SHOULDERS (VARIABLE DETPH)
④ PIPE UNDERDRAIN	①⑨ GUARDRAIL
⑤ AGGREGATE SHOULDERS	①⑩ GUARDRAIL AGGREGATE EROSION CONTROL
⑥ PCC BASE COURSE, 13"	①⑪ AGGREGATE SHOULDERS, TYPE B
⑦ BITUMINOUS SHOULDERS, 8"	
⑧ GUARDRAIL AGGREGATE EROSION CONTROL	

NOTES

- *1/2 "/FT
- **EXISTING GUARDRAIL
- EASTBOUND
- RT. STA. 334+06 TO STA. 337+38
- LT. STA. 333+19 TO STA. 337+38
- WESTBOUND
- RT. STA. 341+21 TO STA. 345+39
- LT. STA. 341+21 TO STA. 343+77
- (SEE SCHEDULES FOR PROPOSED GUARDRAIL)

DRAWING NOT TO SCALE

MODEL: Default
 FILE NAME: p:\projects\688083\CADD\Drawings\688083\Drawings\688083-rtb-cypical.dgn

USER NAME = \$USERS	DESIGNED -	REVISED -
PLOT SCALE = 1:100	DRAWN -	REVISED -
PLOT DATE = 10/20/2023	CHECKED -	REVISED -
	DATE -	REVISED -

**STATE OF ILLINOIS
 DEPARTMENT OF TRANSPORTATION**

TYPICAL SECTIONS	
SCALE:	SHEET 1 OF 1 SHEETS STA. TO STA.

F.A.I. RTE.	SECTION	COUNTY	TOTAL SHEETS	SHEET NO.
74	48[26VB]BY-BY-1]BRR	KNOX	69	13
CONTRACT NO. 68DB3				
ILLINOIS FED. AID PROJECT				



SOUTH APPROACH - WB I-74 LT. STA. 338+28.7
 WOVEN WIRE FENCE REMOVAL AND REPLACEMENT = 130.0 FT.
 FILLING INLETS, SPECIAL = 1.0 EACH (SEE DETAIL A)
 EXISTING 12" CMP TO BE REMOVED, PAID AS
 PIPE CULVERT REMOVAL, SPECIAL = 40.0 FT.
 STONE RIPRAP, CLASS B4 = 23.4 TON
 FILTER FABRIC = 35.1 SQ. YD.
 (SEE DETAIL B)

WB STA. 337+48.2 TO STA. 338+21.7
 HMA SURFACE REMOVAL - BUTT JOINT = 316.1 SQ. YD.
 POLY. HMA SURFACE COURSE = 17.4 TON
 POLY. HMA BINDER COURSE = 9.0 TON
 HMA SHOULDERS = 15.4 TON
 CLASS D PATCHES, TYPE IV, 17" = 62.8 SQ. YD.
 (SEE APPROACH CONNECTOR DETAIL SHEET)

EB LT. STA. 334+45.4 TO STA. 338+20.4
 TBT, TYPE 1 (SPECIAL) TANGENT = 1.0 EACH
 SPBGR TY A 6 FT. POSTS = 287.5 FT.
 TRAFFIC BARRIER TERMINAL, TYPE 6 = 1.0 EACH
 CONCRETE CURB, TYPE B = 15.0 FT.

WB LT. STA. 340+43.7 TO STA. 343+43.1
 TRAFFIC BARRIER TERMINAL, TYPE 6 = 1.0 EACH
 SPBGR TYPE A 6 FT. POSTS = 212.5 FT.
 TRAFFIC BARRIER TERMINAL, TYPE 1 (SPECIAL) TANGENT = 1.0 EACH
 CONCRETE CURB, TYPE B = 15.0 FT.

WB RT. STA. 340+38.8 TO STA. 344+12.9
 TRAFFIC BARRIER TERMINAL, TYPE 6 = 1.0 EACH
 SPBGR TYPE A 6 FT. POSTS = 287.5 FT.
 TRAFFIC BARRIER TERMINAL, TYPE 1 (SPECIAL) TANGENT = 1.0 EACH
 CONCRETE CURB, TYPE B = 15.0 FT.

WB STA. 340+59.2 TO STA. 341+32.6
 HMA SURFACE REMOVAL - BUTT JOINT = 308.8 SQ. YD.
 POLY. HMA SURFACE COURSE = 17.4 TON
 POLY. HMA BINDER COURSE = 9.0 TON
 HMA SHOULDERS = 14.8 TON
 CLASS D PATCHES, TYPE III, 17" = 19.8 SQ. YD.
 CLASS D PATCHES, TYPE IV, 17" = 35.6 SQ. YD.
 (SEE APPROACH CONNECTOR DETAIL SHEET)

SOUTH MEDIAN
 WOVEN WIRE FENCE REMOVAL
 AND REPLACEMENT = 48.0 FT.
 INLET PROTECT = 1.0 EACH

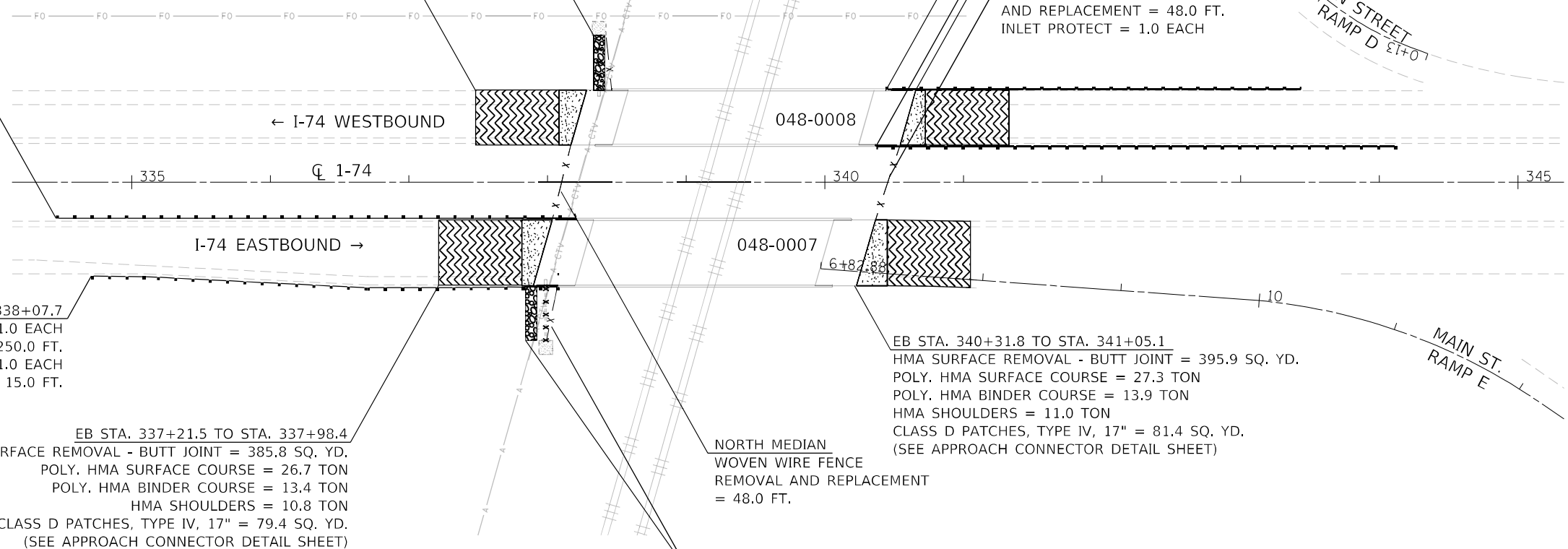

EB RT. STA. 334+70.8 TO STA. 338+07.7
 TBT, TYPE 1 (SPECIAL) TANGENT = 1.0 EACH
 SPBGR TY A 6 FT. POSTS = 250.0 FT.
 TRAFFIC BARRIER TERMINAL, TYPE 6 = 1.0 EACH
 CONCRETE CURB, TYPE B = 15.0 FT.

EB STA. 337+21.5 TO STA. 337+98.4
 HMA SURFACE REMOVAL - BUTT JOINT = 385.8 SQ. YD.
 POLY. HMA SURFACE COURSE = 26.7 TON
 POLY. HMA BINDER COURSE = 13.4 TON
 HMA SHOULDERS = 10.8 TON
 CLASS D PATCHES, TYPE IV, 17" = 79.4 SQ. YD.
 (SEE APPROACH CONNECTOR DETAIL SHEET)

EB STA. 340+31.8 TO STA. 341+05.1
 HMA SURFACE REMOVAL - BUTT JOINT = 395.9 SQ. YD.
 POLY. HMA SURFACE COURSE = 27.3 TON
 POLY. HMA BINDER COURSE = 13.9 TON
 HMA SHOULDERS = 11.0 TON
 CLASS D PATCHES, TYPE IV, 17" = 81.4 SQ. YD.
 (SEE APPROACH CONNECTOR DETAIL SHEET)

NORTH MEDIAN
 WOVEN WIRE FENCE
 REMOVAL AND REPLACEMENT
 = 48.0 FT.

NORTH APPROACH - EB I-74 RT. STA. 337+98.66
 WOVEN WIRE FENCE REMOVAL AND REPLACEMENT = 130.0 FT.
 FILLING INLETS, SPECIAL = 1.0 EACH
 (SEE DETAIL A)
 EXISTING 12" CMP TO BE REMOVED, PAID AS
 PIPE CULVERT REMOVAL, SPECIAL = 40.0 FT.
 STONE RIPRAP, CLASS B4 = 23.4 TON
 FILTER FABRIC = 35.1 SQ. YD.
 (SEE DETAIL B)

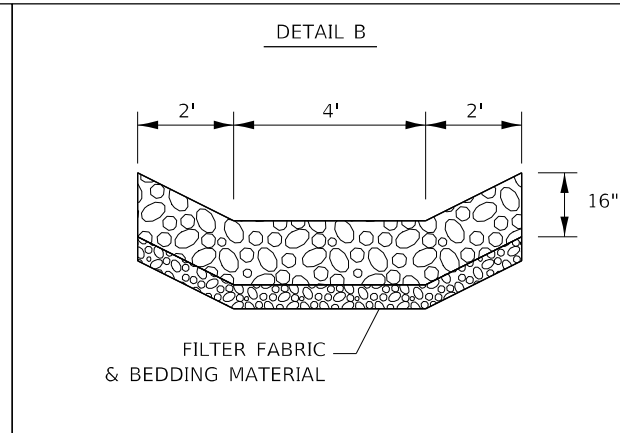
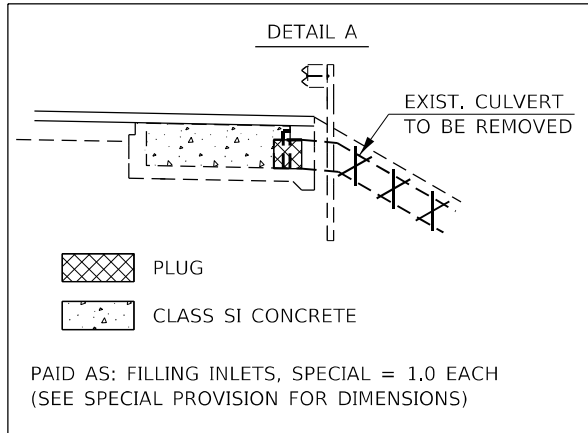

GUARDRAIL NOTES:
 1. TRAFFIC BARRIER TERMINAL, TYPE 1 (SPECIAL) TANGENT WAS ASSUMED AS 50' SECTION WITH 37.5' ALLOTTED TOWARDS THE LENGTH OF NEED.
 2. SEE SCHEDULE FOR LENGTH OF NEED STATIONS.

LEGEND

- x - x - WOVEN WIRE FENCE REMOVAL AND REPLACEMENT
- [Hatched Pattern] CLASS D PATCH
- [Circular Pattern] STONE RIPRAP CLASS B4
- [Wavy Pattern] HMA SURFACE REMOVAL - BUTT JOINT
- X X X REMOVAL

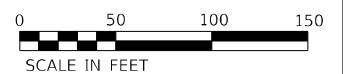

MODEL: Default
 FILE NAME: p:\ultra-pw-bee\fy.com\p\INDOT\Documents\DOT Office\Direct. d\Project\104_68DB3\CADD\31\CAD\Sheets\1468DB3-rt-curb.dgn

USER NAME = \$USERS DRAWN - PLOT SCALE = 1:100 PLOT DATE = 10/20/2023		DESIGNED - CHECKED - DATE -		REVISED - REVISED - REVISED - REVISED -		STATE OF ILLINOIS DEPARTMENT OF TRANSPORTATION		GENERAL PLAN		F.A.I. RTE. 74 SECTION 48(126VB)BY-1)BRR COUNTY KNOX TOTAL SHEETS 69 SHEET NO. 14 CONTRACT NO. 68DB3	
SCALE: SHEET 1 OF 1 SHEETS STA. TO STA.						ILLINOIS FED. AID PROJECT					

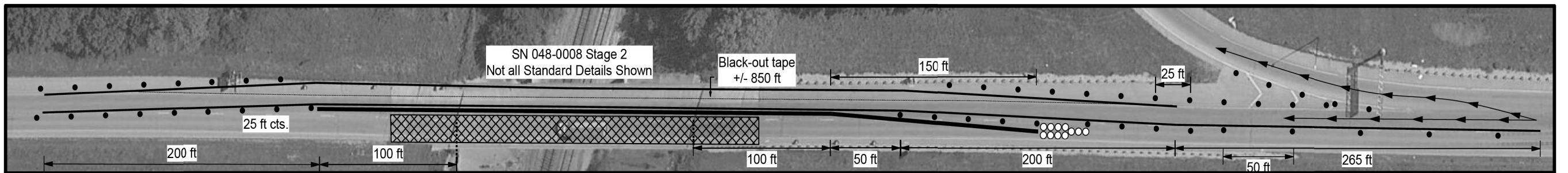
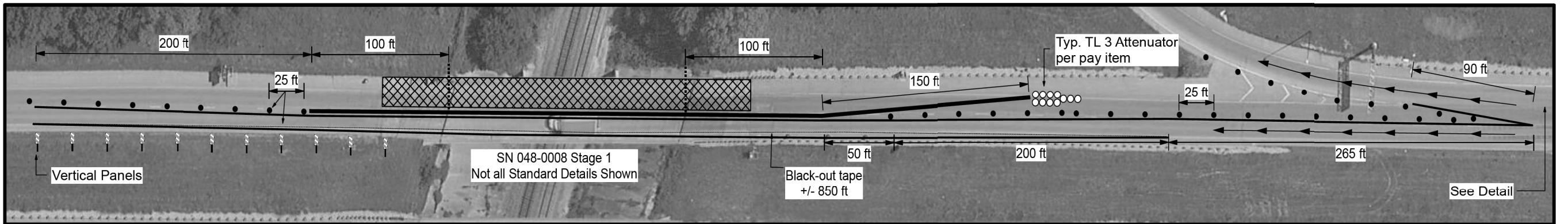
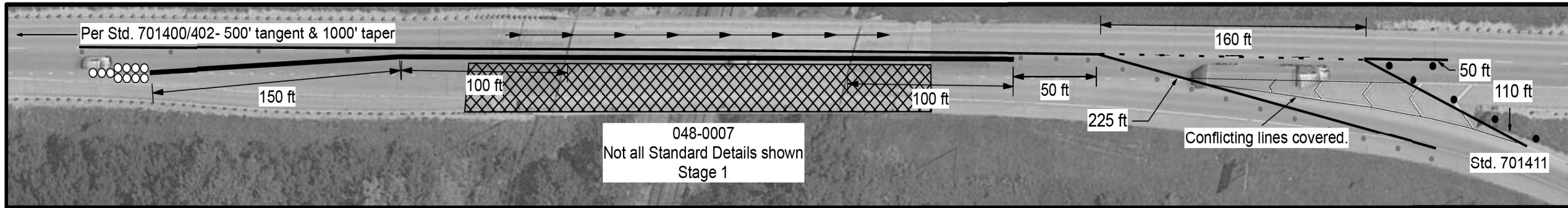

- Devices per standard
- ⊎ Vertical panel
- Blackout tape
- Temp. pavement marking per standard
- ⊙⊙⊙⊙ Test Level III attenuator per pay item
- Temp. concrete barrier

MODEL: Default
 FILE: \\na11fz-pw-bentley.com\P\INDOT\Documents\DOT Office\Director_4\Projects\104_68083\CADD\Drawings\Traffic Control Details.dgn

USER NAME = \$USERS	DESIGNED -	REVISED -
PLOT SCALE = 1:2	DRAWN -	REVISED -
PLOT DATE = 10/20/2023	CHECKED -	REVISED -
	DATE -	REVISED -

**STATE OF ILLINOIS
DEPARTMENT OF TRANSPORTATION**

STAGING DETAILS			
SCALE:	SHEET 1	OF 3 SHEETS	STA. TO STA.

F.A.I. RTE.	SECTION	COUNTY	TOTAL SHEETS	SHEET NO.
74	48[(26VB)BY,BY-1]BRR	KNOX	69	15
CONTRACT NO. 68D83				
ILLINOIS FED. AID PROJECT				

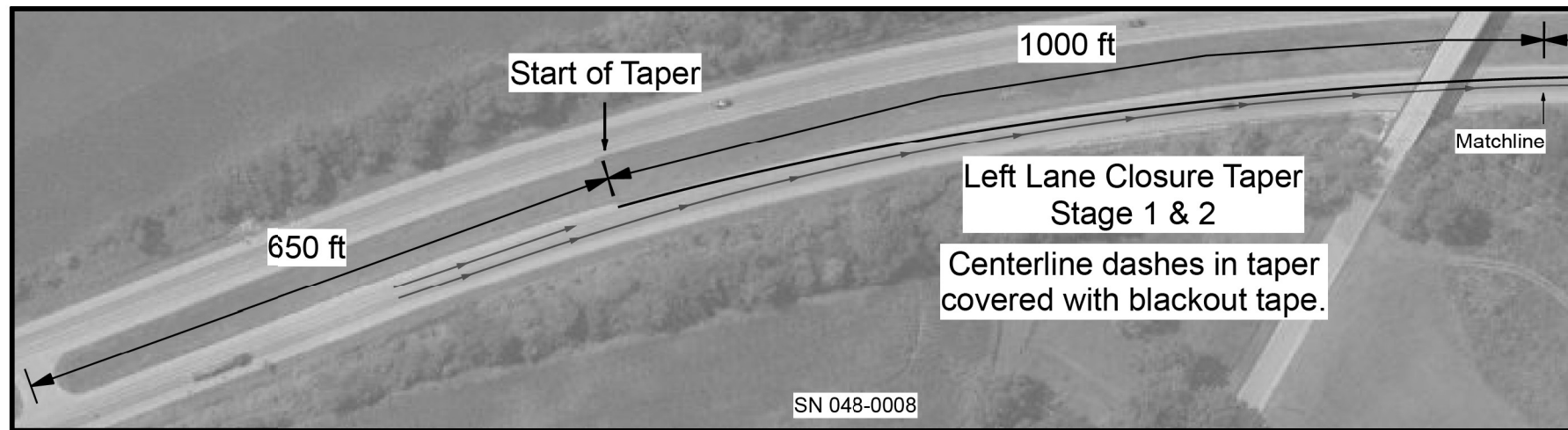
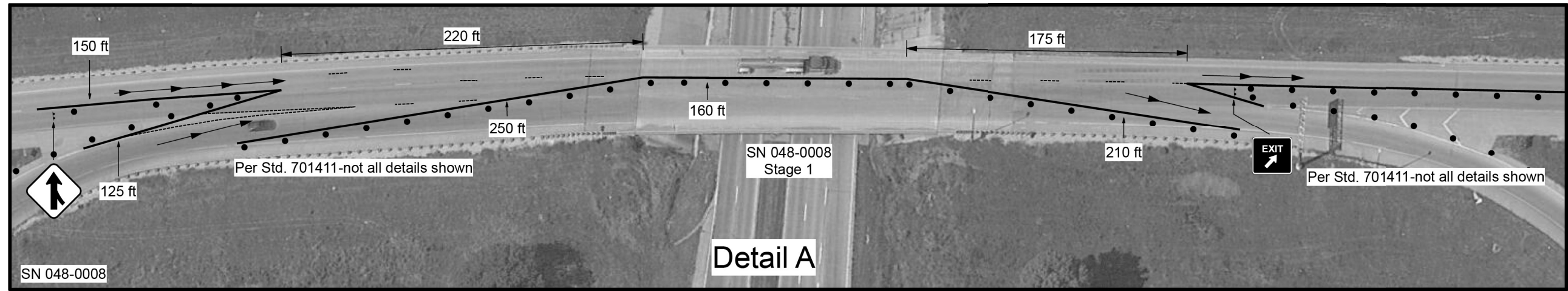

— Temp. pavement marking per Standard

SN 048-0007- A lane shift shall be allowed. The left lane shall be closed. The lane shift shall start 500' beyond the end of taper and end 500' prior to the structure. The contractor shall be aware the lane shift will add approx. 1000' of pavement markings and devices.

SN 048-0007 & 0008- Pavement markings shall be placed from the start to the end of the project. Lane closure tapers shall have the centerline dashes covered with blackout tape.

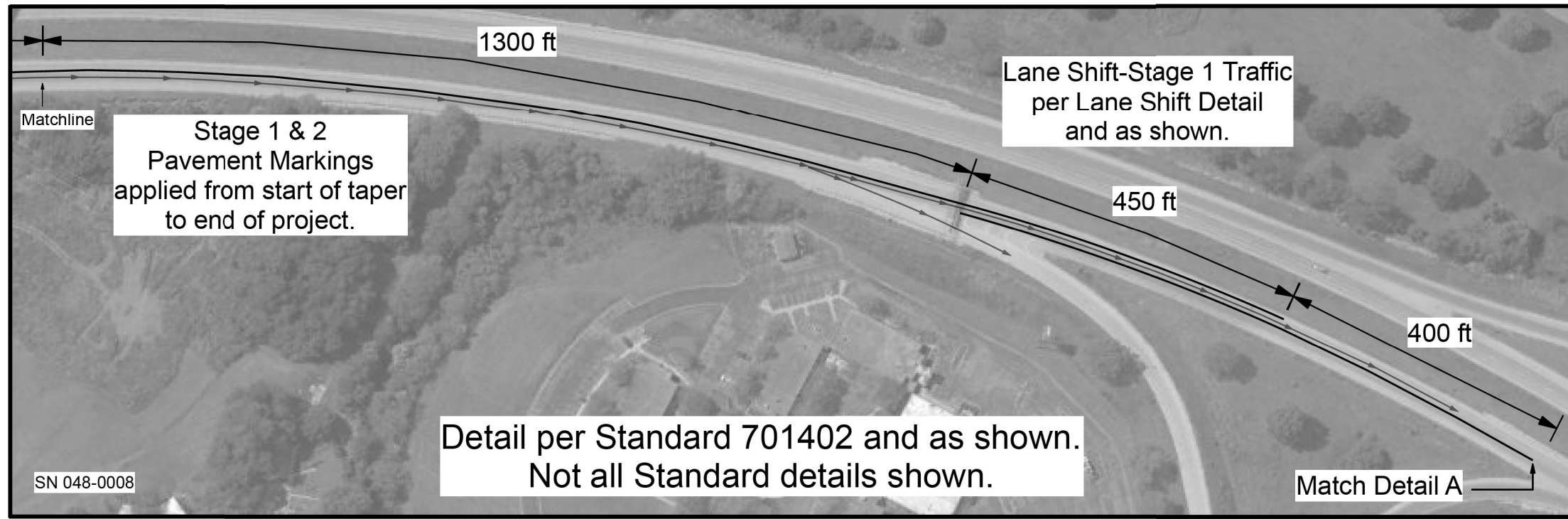

MODEL: Default
 FILE: 68803\CADD\Drawings\DOT\Office\Drawings\68803\CADD\Drawings\DOT\Traffic Control Details.dgn
 PROJECT: 68803\CADD\Drawings\DOT\Office\Drawings\68803\CADD\Drawings\DOT\Traffic Control Details.dgn

USER NAME = \$USERS	DESIGNED -	REVISED -
	DRAWN -	REVISED -
PLOT SCALE = 1:2	CHECKED -	REVISED -
PLOT DATE = 10/20/2023	DATE -	REVISED -

**STATE OF ILLINOIS
DEPARTMENT OF TRANSPORTATION**

STAGING DETAILS			
SCALE:	SHEET 2	OF 3 SHEETS	STA. TO STA.

F.A.I. RTE.	SECTION	COUNTY	TOTAL SHEETS	SHEET NO.
74	48[(26VB)BY, BY-1]BRR	KNOX	69	16
CONTRACT NO. 68D83				
ILLINOIS FED. AID PROJECT				

TRAFFIC CONTROL LANE SHIFT Contract # 68D83

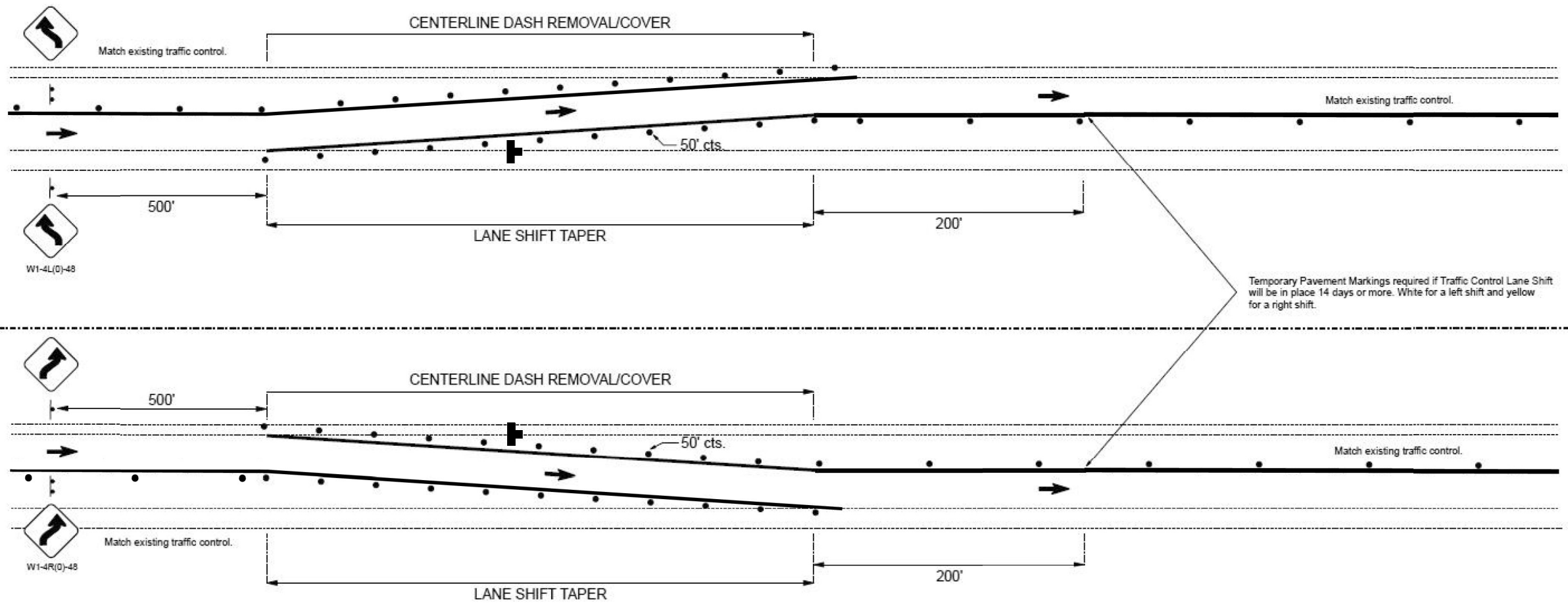

Temporary Pavement Markings required if Traffic Control Lane Shift will be in place 14 days or more. White for a left shift and yellow for a right shift.

LANE SHIFT TAPER LENGTH

NORMAL POSTED SPEED LIMIT	LANE SHIFT TAPER
65 MPH OR GREATER	450 FT.
55 MPH	350 FT.
50 MPH	300 FT.
45 MPH OR LESS	275 FT.

SYMBOLS

- DRUM WITH STEADY BURN MONO-DIRECTIONAL LIGHT (LIGHT IN TAPERS ONLY)
- TEMPORARY SIGN STAND MOUNT- CLOSED LANE/ LESS THAN 14 DAYS
- POST MOUNTED SIGN STAND MOUNT- GREATER THAN 14 DAYS

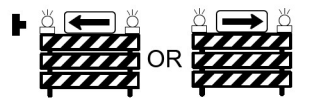

GENERAL NOTES

- TO BE USED WHEN FIELD CONDITIONS WARRANT THE NEED FOR A LANE SHIFT DUE TO ADJACENT CONSTRUCTION PROJECTS OR OTHER MOTORIST/ WORKER SAFETY NEEDS.
- THE RESIDENT ENGINEER MUST APPROVE THE USE OF THIS DETAIL.
- CENTERLINE DASHES SHALL BE COVERED/REMOVED IF LANE SHIFT WILL BE IN PLACE GREATER THAN 24 HOURS.
- DEVICES IN LANE SHIFT SHALL HAVE A STEADY BURN MONO-DIRECTIONAL LIGHT.

STATE OF ILLINOIS
DEPARTMENT OF TRANSPORTATION
REGION 3/ DISTRICT 4
TRAFFIC CONTROL LANE SHIFT TYPICAL

MODEL: Default FILE: NAME: p:\projects\68D83\CADD\Drawings\Traffic Control Details.dgn PROJECT: 68D83\CADD\Drawings\Traffic Control Details.dgn

USER NAME = SUsers	DESIGNED -	REVISED -
	DRAWN -	REVISED -
PLOT SCALE = 1:2	CHECKED -	REVISED -
PLOT DATE = 10/20/2023	DATE -	REVISED -

STATE OF ILLINOIS
DEPARTMENT OF TRANSPORTATION

STAGING DETAILS

SCALE: SHEET 3 OF 3 SHEETS STA. TO STA.

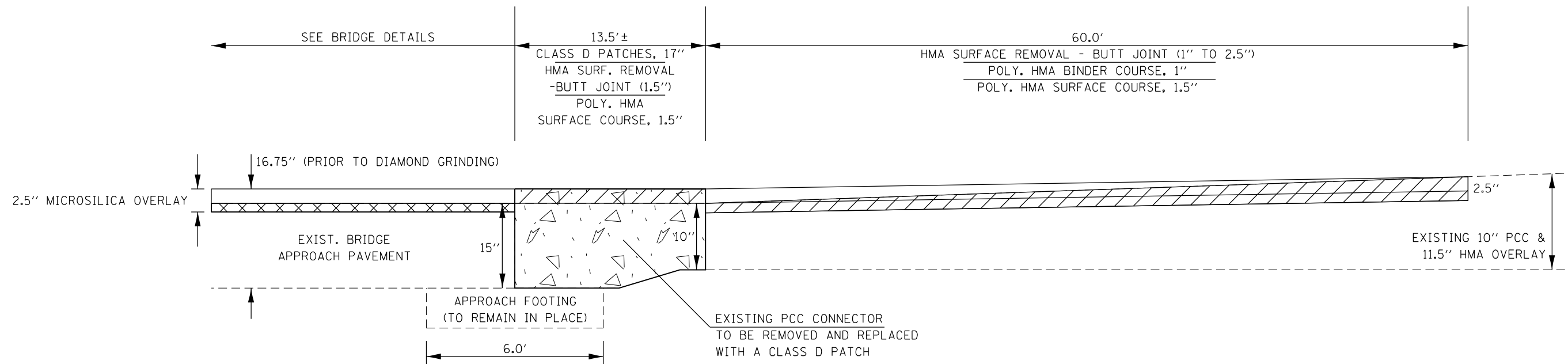

F.A.I. RTE.	SECTION	COUNTY	TOTAL SHEETS	SHEET NO.
74	48[(26VB)BY, BY-1]BRR	KNOX	69	17
CONTRACT NO. 68D83				
ILLINOIS FED. AID PROJECT				



PLAN NOTES:

1. CLASS D PATCHES SHALL MATCH THE ELEVATION OF THE MICROSILICA OVERLAY.
2. THE CONTRACTOR SHALL MILL OFF THE 1:1 AREA OF CLASS D PATCHES PRIOR TO PLACING CLASS D PATCHES IN STAGE II.
3. 1.5" SHALL BE MILLED OFF CLASS D PATCHES PRIOR TO PLACEMENT OF SURFACE COURSE.
4. FINAL BRIDGE DIAMOND GRINDING SHALL EXTEND 25' BEYOND LIMITS OF BRIDGE APPROACH.

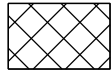
LEGEND

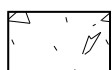
-  3/4" SCARAFICATION
-  HMA SURFACE REMOVAL - BUTT-JOINT (1" TO 2.5")
-  CLASS D PATCH

DRAWING NOT TO SCALE

MODEL: Default
 FILE: \\mfrs-pw-bentley.com\P\DOT\Documents\DOT Office\Director_4\Project\ID4_68D83\CADD\Drawn\CAD\Sheet\1468D83-1b-detail.dgn

USER NAME = \$USERS	DESIGNED -	REVISED -
	DRAWN -	REVISED -
PLOT SCALE = 1:100	CHECKED -	REVISED -
PLOT DATE = 10/20/2023	DATE -	REVISED -

**STATE OF ILLINOIS
DEPARTMENT OF TRANSPORTATION**

APPROACH CONNECTOR DETAIL

SCALE: SHEET 1 OF 2 SHEETS STA. TO STA.

F.A.I. RTE.	SECTION	COUNTY	TOTAL SHEETS	SHEET NO.
74	48[26VB)BY-BY-1]BRR	KNOX	69	18
CONTRACT NO. 68D83				
ILLINOIS FED. AID PROJECT				

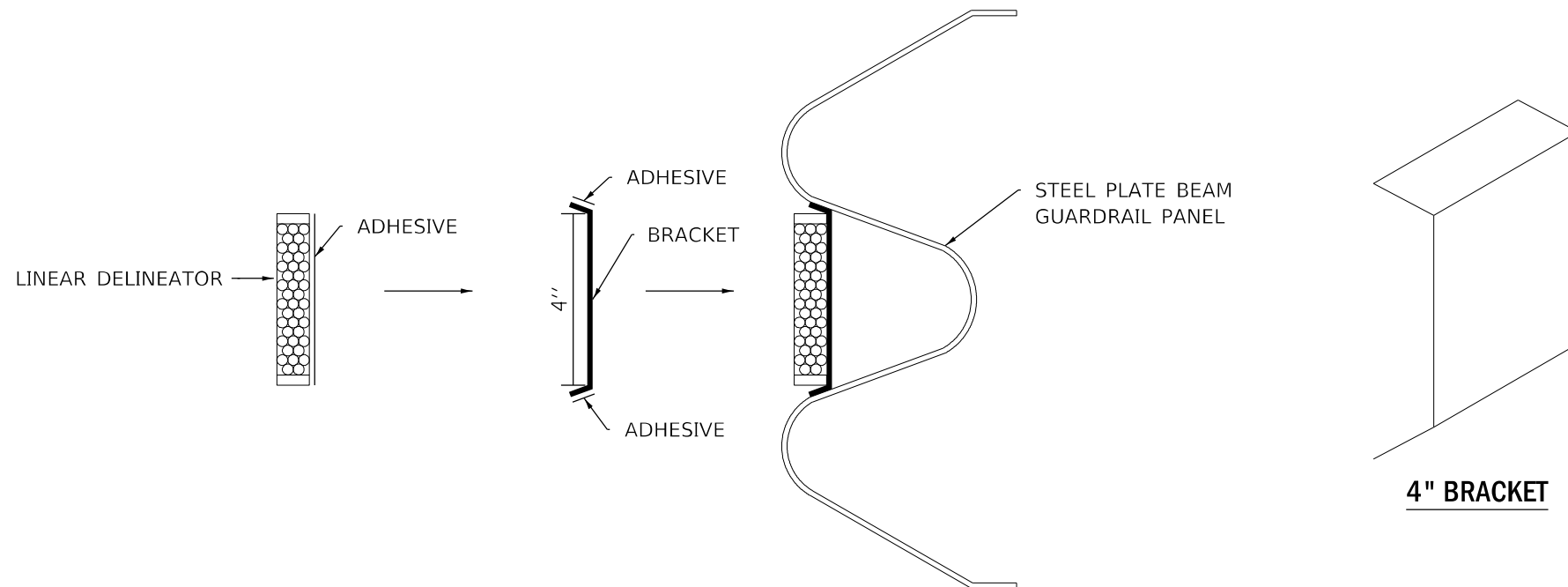

LINEAR DELINEATOR APPLICATION TO STANDARD GALVANIZED GUARDRAIL

LINEAR DELINEATOR SHALL BE APPLIED ACCORDING TO THE MANUFACTURER'S RECOMMENDATIONS

SEE LINEAR DELINEATOR PANELS, 4 INCH
SPECIAL PROVISION FOR ADDITIONAL DETAILS

MODEL: Default
 FILE NAME: p:\ultra-cw-bee-fwy.com\PIV\DOT\Documents\DOT Office\Director_4\Project\ID_68D83\CADD\Drawings\Civil\Sheet\68D83-4b-detail.dgn

USER NAME = \$USERS	DESIGNED -	REVISED -
	DRAWN -	REVISED -
PLOT SCALE = 1:100	CHECKED -	REVISED -
PLOT DATE = 10/20/2023	DATE -	REVISED -

**STATE OF ILLINOIS
DEPARTMENT OF TRANSPORTATION**

LINEAR DELINEATOR PANEL, 4" DETAIL

SCALE: SHEET 2 OF 2 SHEETS STA. TO STA.

F.A.I. RTE.	SECTION	COUNTY	TOTAL SHEETS	SHEET NO.
74	48[(26VB)BY,BY-1]BRR	KNOX	69	19
CONTRACT NO. 68D83				
ILLINOIS FED. AID PROJECT				

Existing Structure: 048-0007(EB) & 048-0008(WB) built as dual 3 span continuous wide flange structures in 1963 to carry F.A.I. 74 over BNSF Railroad. The bridges were widened and rehabilitated in 1994. The bridges will be rehabilitated again with the scope of work shown. Stage construction shall be utilized to maintain one lane of traffic in each direction at all times.

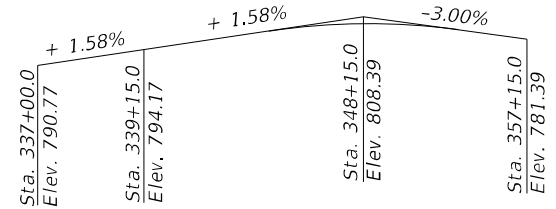
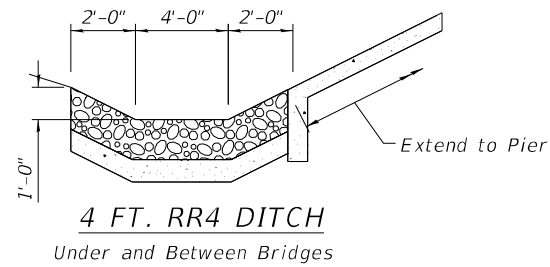
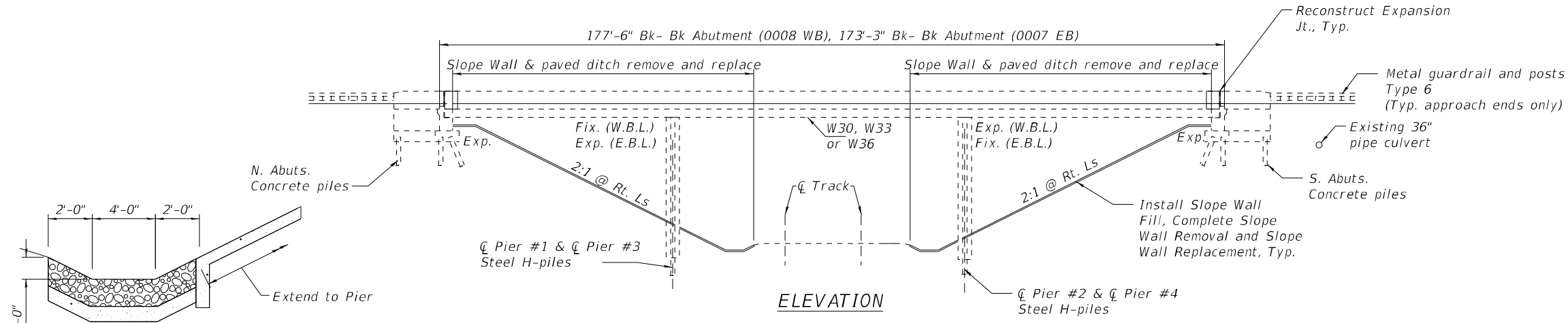

***PROFILE GRADE**
(P.G. and Deck Elevation shown are 2" above original concrete deck)
* Taken from Existing Plans

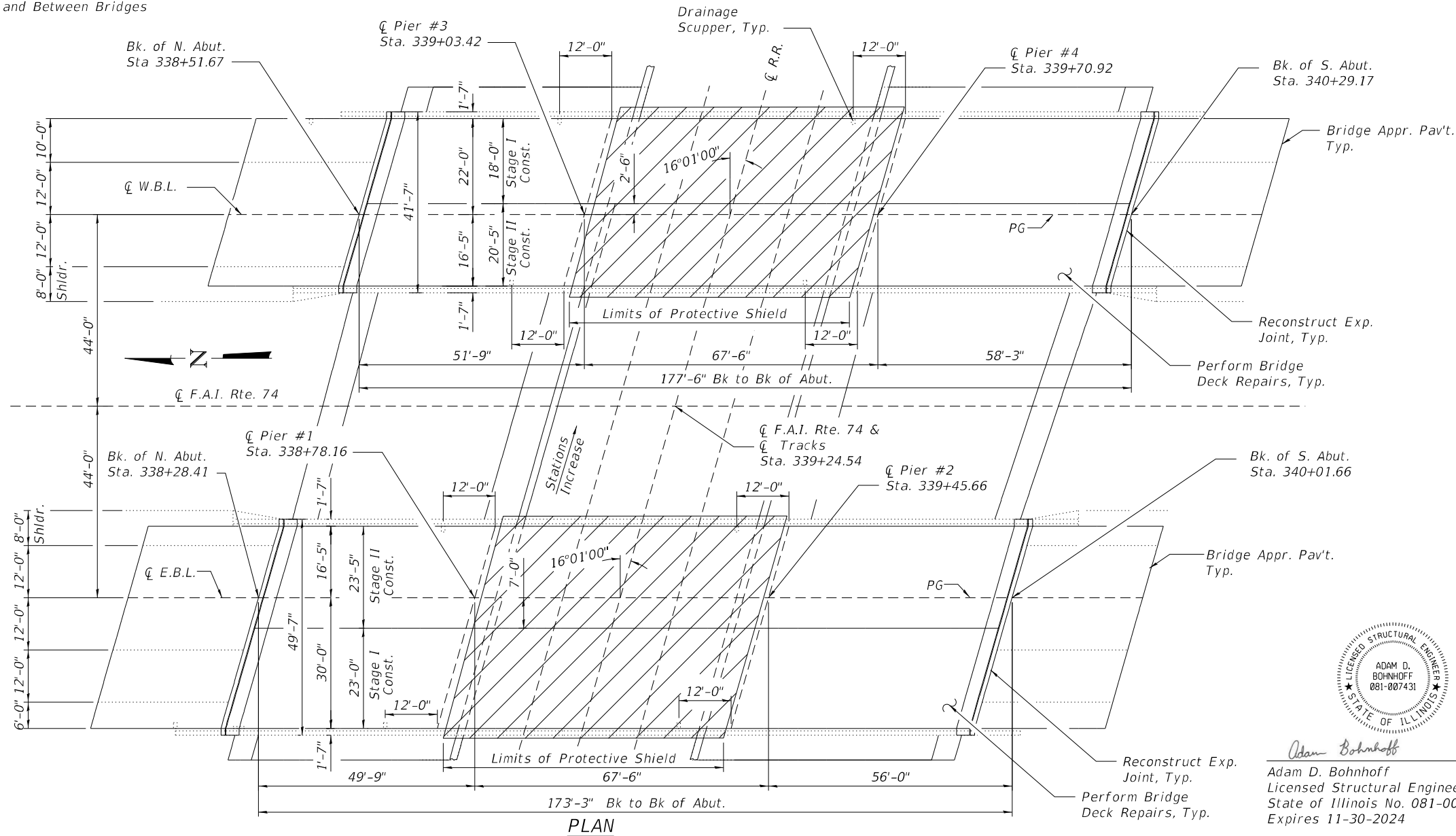

DESIGN STRESSES

EXISTING
f'c = 3,500 psi
fs = 20,000 psi Structural Steel (A36 & M270 Grade 36)
fy = 40,000 psi (Reinforcement)

NEW CONSTRUCTION
f'c = 4,000 psi
fy = 60,000 psi (Reinforcement)
fy = 36,000 psi Structural Steel (M270 Grade 36)

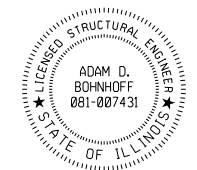

Adam Bohnhoff
Adam D. Bohnhoff
Licensed Structural Engineer
State of Illinois No. 081-007431
Expires 11-30-2024

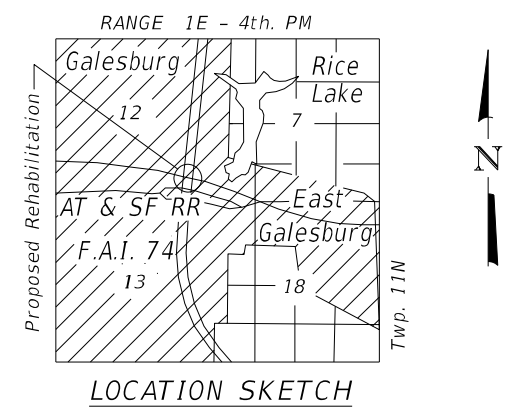

STATE OF ILLINOIS
DEPARTMENT OF TRANSPORTATION

GENERAL PLAN AND ELEVATION
S.N. 048-0008 (W.B.) & 048-0007 (E.B.)

SHEET 1 OF 34 SHEETS

F.A.I. RTE.	SECTION	COUNTY	TOTAL SHEETS	SHEET NO.
74	48([26VB]BY-BY-1)BR	KNOX	69	20
ILLINOIS FED. AID PROJECT			CONTRACT NO. 68D83	

MODEL: Default
FILE NAME: P:\Effingham\4852 - IDOT PTB 198-018_D4_VVAWork Order #10% Rehab WO 10 RT11 General Plan and Elev.dgn
10/19/2023 3:51:32 PM

CIVIL DESIGN, INC.
WBE | DBE
EFFINGHAM, IL
LICENSE #184.003222

USER NAME =	DESIGNED - RBT	REVISED -
PLOT SCALE =	CHECKED - MJH	REVISED -
PLOT DATE =	DRAWN - RBT	REVISED -
	CHECKED - MJH	REVISED -

TOTAL BILL OF MATERIAL

ITEM	UNIT	048-0008	048-0007	TOTAL
Granular Embankment, Special	Ton	483	15	498
Stone Riprap, Class B4	Ton	125	148	273
Filter Fabric	Sq. Yd.	125	150	275
Concrete Removal	Cu. Yd.	10.6	13.2	23.8
Slope Wall Removal	Sq. Yd.	1,191	1,218	2,409
Protective Shield	Sq. Yd.	300	358	658
Concrete Superstructure	Cu. Yd.	12.8	15.8	28.6
Protective Coat	Sq. Yd.	772	909	1,681
Furnishing and Erecting Structural Steel	Pound	---	360	360
Reinforcement Bars, Epoxy Coated	Pound	1,760	2,040	3,800
Bar Splicers	Each	24	24	48
Slope Wall 4 Inch	Sq. Yd.	1,050	1,062	2,112
Preformed Joint Strip Seal	Foot	84	102	186
Epoxy Crack Injection	Foot	34	58	92
Bridge Deck Grooving (Longitudinal)	Sq. Yd.	628	925	1,553
Structural Steel Removal	Pound	---	280	280
Structural Steel Repair	Pound	---	210	210
Bridge Deck Scarification 3/4"	Sq. Yd.	967	1,146	2,113
Bridge Deck Microsilica Concrete Overlay 2 1/2"	Sq. Yd.	967	1,146	2,113
Structural Repair of Concrete (Depth Equal to or Less than 5 Inches)	Sq. Ft.	3	6	9
Deck Slab Repair (Full Depth, Type 1)	Sq. Yd.	22.3	26.5	48.8
Drainage Scuppers to be Adjusted	Each	4	4	8
Diamond Grinding (Bridge Section)	Sq. Yd.	1,091	1,324	2,415
Railroad Protective Liability Insurance	L. Sum	---	---	1

INDEX OF SHEETS

- 1 General Plan and Elevation (S.N. 048-0008 and S.N. 048-0007)
- 2 General Data (S.N. 048-0008 and S.N. 048-0007)
- 3 Existing and Proposed Typical Cross Sections (S.N. 048-0008)
- 4 Stage Construction Details (S.N. 048-0008)
- 5 Existing and Proposed Typical Cross Sections (S.N. 048-0007)
- 6 Stage Construction Details (S.N. 048-0007)
- 7 Temporary Concrete Barrier (S.N. 048-0008 and S.N. 048-0007)
- 8 Wearing Surface Plan (S.N. 048-0008 and S.N. 048-0007)
- 9 Deck Slab Repair Plan (S.N. 048-0008 and S.N. 048-0007)
- 10 Beam End Strengthening (S.N. 048-0007)
- 11 Slope Wall Repair (S.N. 048-0008 and S.N. 048-0007)
- 12 Substructure Repair (S.N. 048-0008 and S.N. 048-0007)
- 13 Superstructure Repair Plan - Concrete Removal Details (S.N. 048-0008)
- 14 Superstructure Repair Plan - Deck Reinforcement Details (S.N. 048-0008)
- 15 Superstructure Repair Plan - Concrete Removal Details (S.N. 048-0007)
- 16 Superstructure Repair Plan - Deck Reinforcement Details (S.N. 048-0007)
- 17 Preformed Joint Strip Seal Details (S.N. 048-0008 and S.N. 048-0007)
- 18 Bar Splicer Assembly and Mechanical Bar Splicer Details (S.N. 048-0008 and S.N. 048-0007)
- 19-34 Existing Plans

PROPOSED WORK

1. Perform Bridge Deck Scarification on Bridge Deck, and Approach Slabs (S.N. 048-0008 and S.N. 048-0007)
2. Removal of Deck Ends and Parapet at Deck Ends (S.N. 048-0008 and S.N. 048-0007).
3. Removal of Existing Joints (S.N. 048-0008 and S.N. 048-0007).
4. Perform Beam End Strengthening and Diaphragm Replacement (S.N. 048-0007).
5. Pour Deck Ends (S.N. 048-0008 and S.N. 048-0007).
6. Pour Parapets (S.N. 048-0008 and S.N. 048-0007).
7. Insert Rubber Strip Seal into Locking Edge Rails (S.N. 048-0008 and S.N. 048-0007).
8. Place Microsilica Concrete Overlay on Bridge Deck, and Approach Slabs (S.N. 048-0008 and S.N. 048-0007).
9. Perform Diamond Grinding and Longitudinal Deck Grooving (S.N. 048-0008 and S.N. 048-0007).
10. Perform Substructure Repairs (S.N. 048-0008 and S.N. 048-0007).
11. Apply Protective Coat (S.N. 048-0008 and S.N. 048-0007).
12. Install Slope Wall Fill, Complete Slope Wall Removal and replacement (S.N. 048-0008 and S.N. 048-0007).

GENERAL NOTES

Plan dimensions and details relative to the existing structure have been taken from existing plans are subject to nominal construction variations. The Contractor shall field verify existing dimensions and details affecting new construction and make necessary approved adjustments prior to construction or ordering of materials. Such variations shall not be cause for additional compensation for a change in scope of the work, however, the Contractor will be paid for the quantity actually furnished at the unit price bid for the work.

Reinforcement bars designated (E) shall be epoxy coated.

Up to ¼ inch to be ground off the bridge deck and the bridge approach slabs through Diamond Grinding.

Prior to pouring the new concrete deck, all heavy or loose rust, loose mill scale, and other loose detrimental foreign material shall be removed from the surfaces in contact with concrete. Tightly adhered paint may remain unless otherwise noted. Removal shall be accomplished by methods that will not damage the steel and the cost will be paid for according to Article 109.4 of the Standard Specifications.

Existing structural steel that will be in contact with new structural steel shall be cleaned and painted as required by the Special Provision "Cleaning and Painting Contact Surface Areas of Existing Steel Structures".

Existing reinforcement shall be cleaned, straightened and incorporated into the new construction. Any reinforcement bars that are damaged during concrete removal operations shall be repaired or replaced using approved bar splicer or anchorage system. Cost included with Concrete Removal.

Joint openings shall be adjusted according to Article 520.04 of the Std. Specs. when the deck is poured at an ambient temperature other than 50°F.

Expansion joints shall be fabricated and installed according to the manufacturer's recommendations and as approved by the Engineer.

Expansion joints shall be fabricated to conform to the existing cross slopes of the bridge.

Protective Coat shall be applied from end to end of approaches and to the faces and tops of the new parapet concrete.

Slope wall shall be reinforced with welded-wire fabric, 6 in. x 6 in. - W4.0 x W4.0, weighing 58 pounds per 100 sq. ft.

Synthetic fibers shall be included in the bridge deck concrete overlay specified. See Special Provisions.

All new structural steel and bearing assembly shall be hot-dip galvanized. See Special Provisions for "Hot Dip Galvanizing for Structural Steel".

The contractor must not use the railroad right of way for storage of materials or equipment during construction. The railroad right of way must remain clear at all times. The contractor must plan and perform the work in a manner such that the railroad tracks at the project location remain fully capable of operating rail traffic throughout the work period and rail traffic is not delayed or otherwise impacted due to the work being performed.

MODEL: Default
FILE NAME: P:\Effingham\4552 - IDOT FTB 198-018_D4_VVAWork Order #10Y Rehab WO 10 RT2 General Data.dgn



CIVIL DESIGN, INC.
WBE / DBE
EFFINGHAM, IL
LICENSE #184.003222

USER NAME =	DESIGNED - RBT	REVISED -
	CHECKED - MJH	REVISED -
PLOT SCALE =	DRAWN - RBT	REVISED -
PLOT DATE =	CHECKED - MJH	REVISED -

**STATE OF ILLINOIS
DEPARTMENT OF TRANSPORTATION**

**GENERAL DATA
S.N. 048-0008 (W.B.) & 048-0007 (E.B.)**

SHEET 2 OF 34 SHEETS

F.A.I. RTE.	SECTION	COUNTY	TOTAL SHEETS	SHEET NO.
74	48[(26VB)BY-BY-1]BRR	KNOX	69	21
			CONTRACT NO. 68D83	
		ILLINOIS	FED. AID PROJECT	

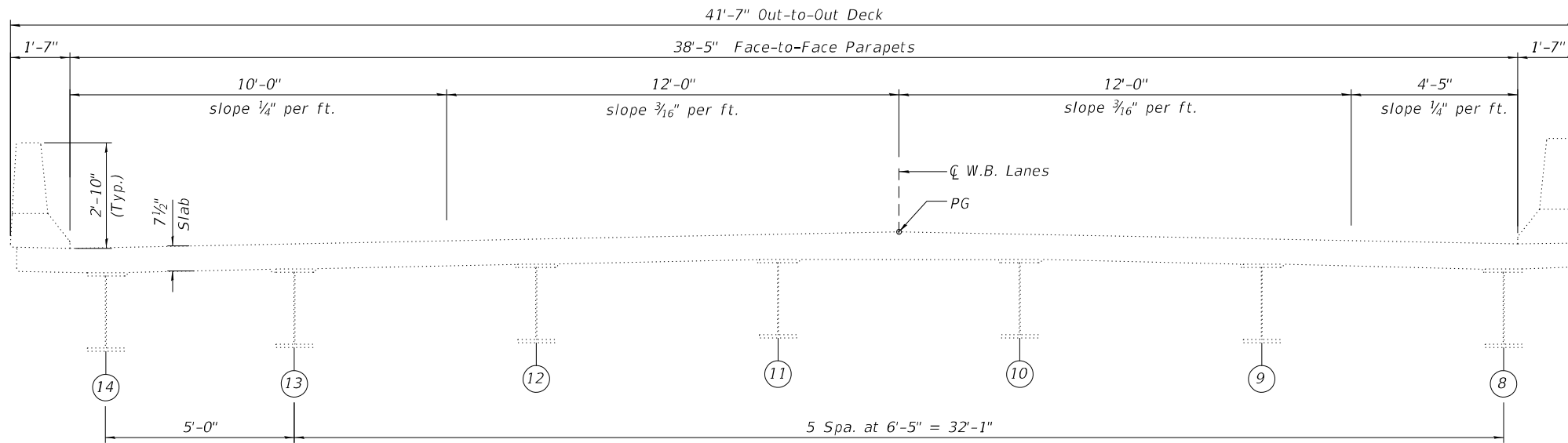

EXISTING CROSS SECTION

(Looking South)

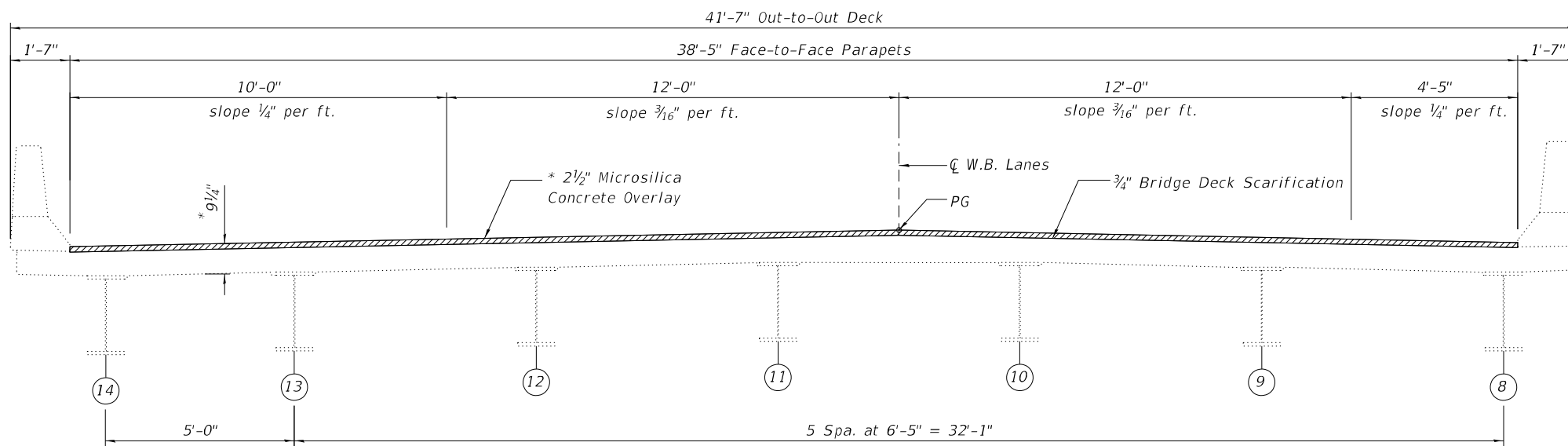

PROPOSED CROSS SECTION

(Looking South)

* Prior to 1/4" Diamond Grinding

MODEL: Default
 FILE NAME: P:\Effingham\4552 - IDOT FTB 198-018_D4_VVAWork Order #10\Rehab WO 10 RT13 Exist & Proposed 0008.dgn
 10/19/2023 3:51:54 PM



CIVIL DESIGN, INC.
 WBE | DBE
 EFFINGHAM, IL
 LICENSE # 184.003222

USER NAME =	DESIGNED - RBT	REVISED -
	CHECKED - MJH	REVISED -
PLOT SCALE =	DRAWN - RBT	REVISED -
PLOT DATE =	CHECKED - MJH	REVISED -

STATE OF ILLINOIS
 DEPARTMENT OF TRANSPORTATION

EXISTING AND PROPOSED TYPICAL CROSS SECTIONS
 S.N. 048-0008 (W.B.)

SHEET 3 OF 34 SHEETS

F.A.I. RTE.	SECTION	COUNTY	TOTAL SHEETS	SHEET NO.
74	48[(26VB)BY,BY-1]BRR	KNOX	69	22
			CONTRACT NO. 68D83	
		ILLINOIS	FED. AID PROJECT	

MODEL: Default
 FILE NAME: X:\Effingham\4852 - IDOT PTB 196-018_D4_VV\Work Order # 10\Correspondence\Sen\2023.10.16_IDOT (Revised Set)\CAD FILES\0480007-0480008-68D83-004-Stage_Constr.dgn
 10/18/2023 6:12:27 AM

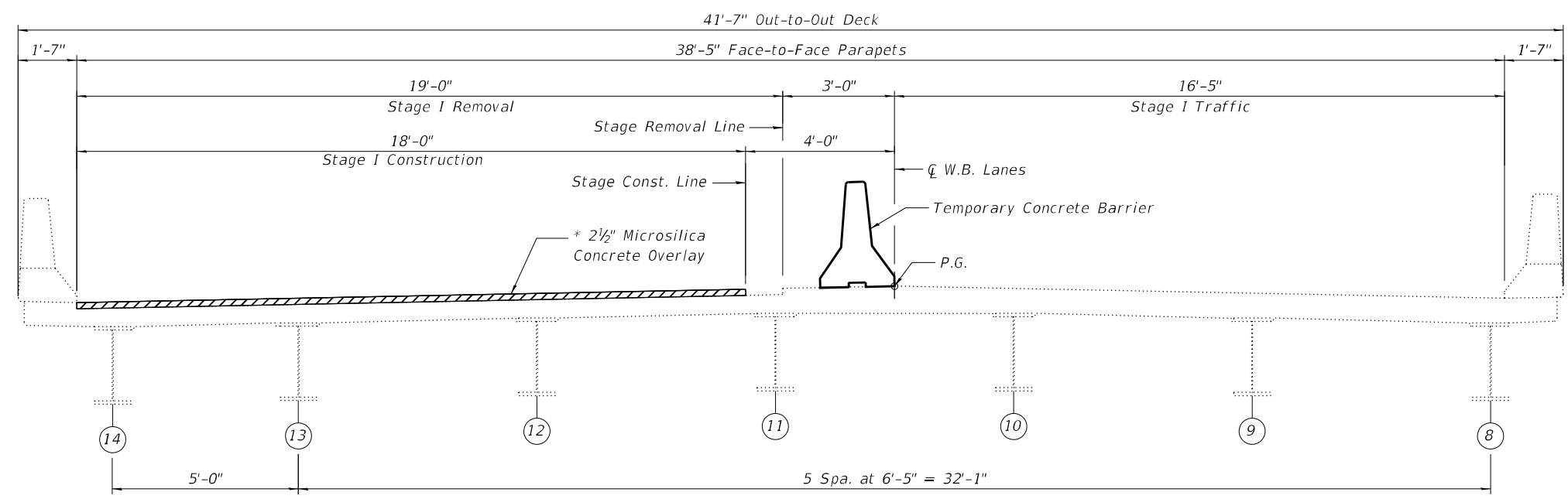

STAGE I CONSTRUCTION DETAILS
 (Looking South)

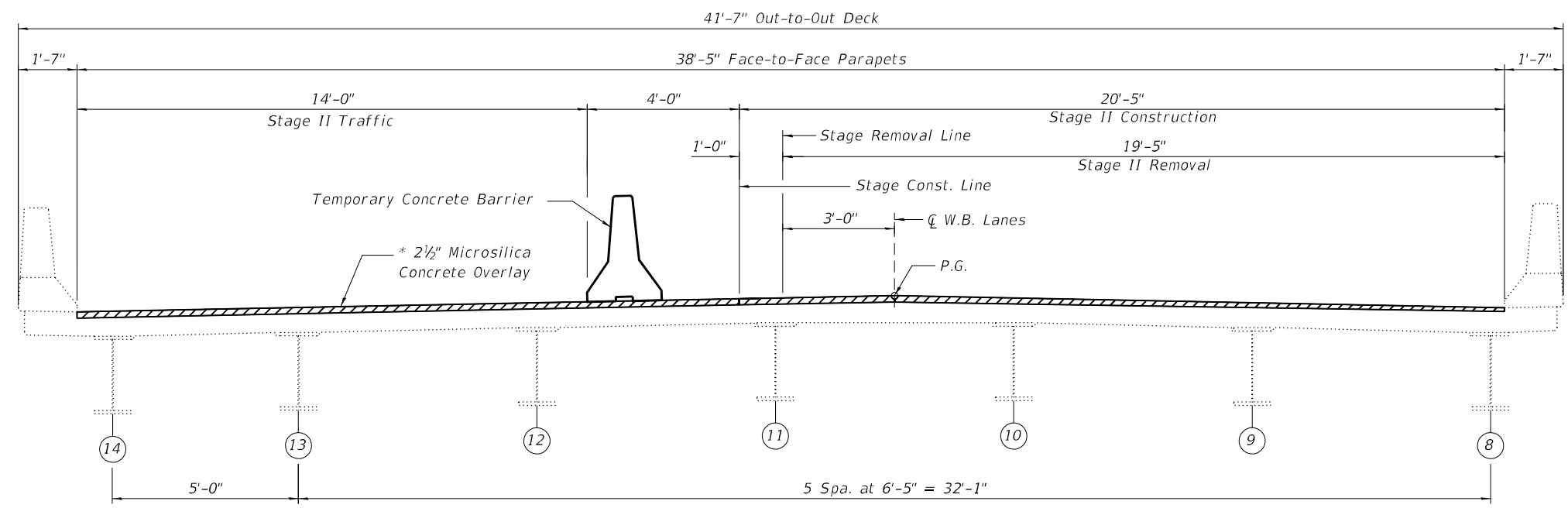

STAGE II CONSTRUCTION DETAILS
 (Looking South)

* (Prior to ¼" Diamond Grinding)



CIVIL DESIGN, INC.
 WBE / DBE
 EFFINGHAM, IL
 LICENSE # 184.003222

USER NAME =	DESIGNED - RBT	REVISED -
CHECKED - MJH	CHECKED - MJH	REVISED -
PLOT SCALE =	DRAWN - RBT	REVISED -
PLOT DATE =	CHECKED - MJH	REVISED -

STATE OF ILLINOIS
 DEPARTMENT OF TRANSPORTATION

STAGE CONSTRUCTION DETAILS
 S.N. 048-0008 (W.B.)

SHEET 4 OF 34 SHEETS

F.A.I. RTE.	SECTION	COUNTY	TOTAL SHEETS	SHEET NO.
74	48[(26VB)BY, BY-1]BRR	KNOX	69	23
CONTRACT NO. 68D83				
ILLINOIS		FED. AID PROJECT		

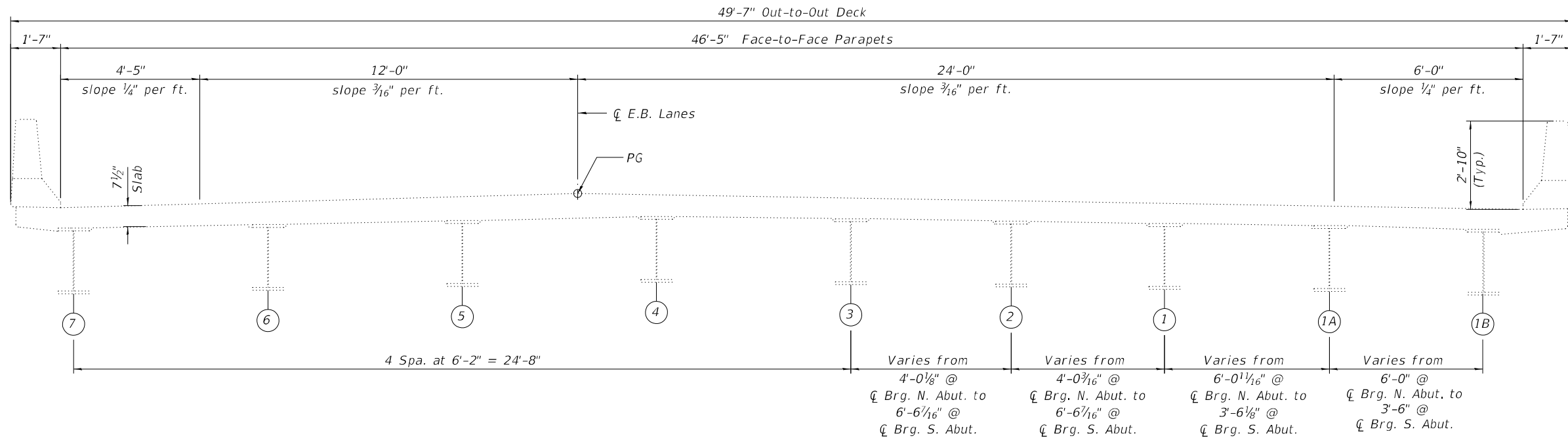

EXISTING CROSS SECTION
(Looking South)

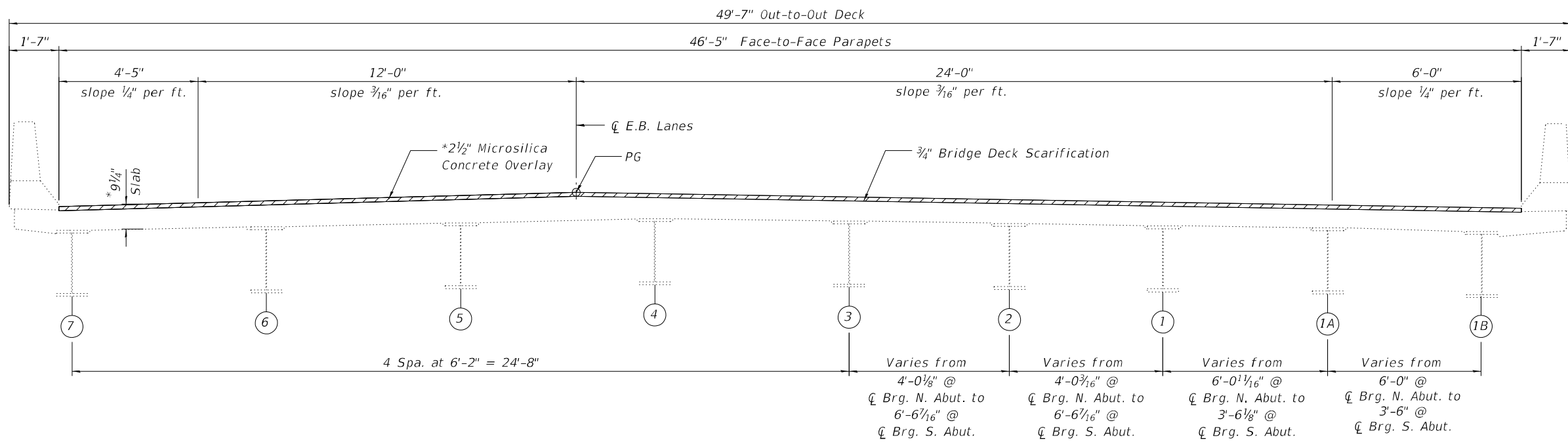

* (Prior to 1/4" Diamond Grinding)

PROPOSED CROSS SECTION
(Looking South)

MODEL: Default
FILE NAME: P:\Effingham\4852 - IDOT FTB 198-018_D4_VVAWork Order #10\Rehab WO 10 RT15 Exist & Proposed 0007.dgn
10/19/2023 3:51:56 PM



CIVIL DESIGN, INC.
WBE / DBE
EFFINGHAM, IL
LICENSE # 184.003222

USER NAME =	DESIGNED - RBT	REVISED -
	CHECKED - MJH	REVISED -
PLOT SCALE =	DRAWN - RBT	REVISED -
PLOT DATE =	CHECKED - MJH	REVISED -

STATE OF ILLINOIS
DEPARTMENT OF TRANSPORTATION

EXISTING AND PROPOSED TYPICAL CROSS SECTIONS
S.N. 048-0007 (E.B.)

SHEET 6 OF 34 SHEETS

F.A.I. RTE.	SECTION	COUNTY	TOTAL SHEETS	SHEET NO.
74	48[(26VB)BY.BY-1]BRR	KNOX	69	24
			CONTRACT NO. 68D83	
		ILLINOIS FED. AID PROJECT		

MODEL: Default
 FILE NAME: X:\Effingham\4852 - IDOT PTB 195-018_D4_VV\Work Order # 10\Correspondence\Sen\2023.10.16_IDOT (Revised Set)\CAD FILES\0480007-0480008-68D83-006-Stage_Constr.dgn
 10/18/2023 6:03:28 AM

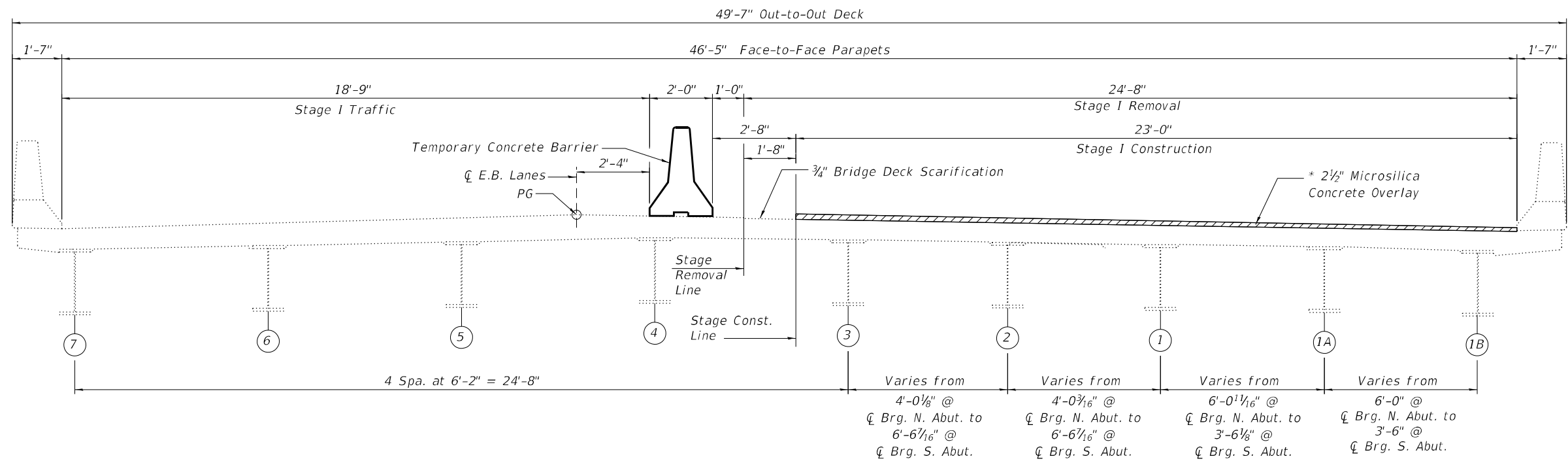

STAGE I CONSTRUCTION DETAILS
(Looking South)

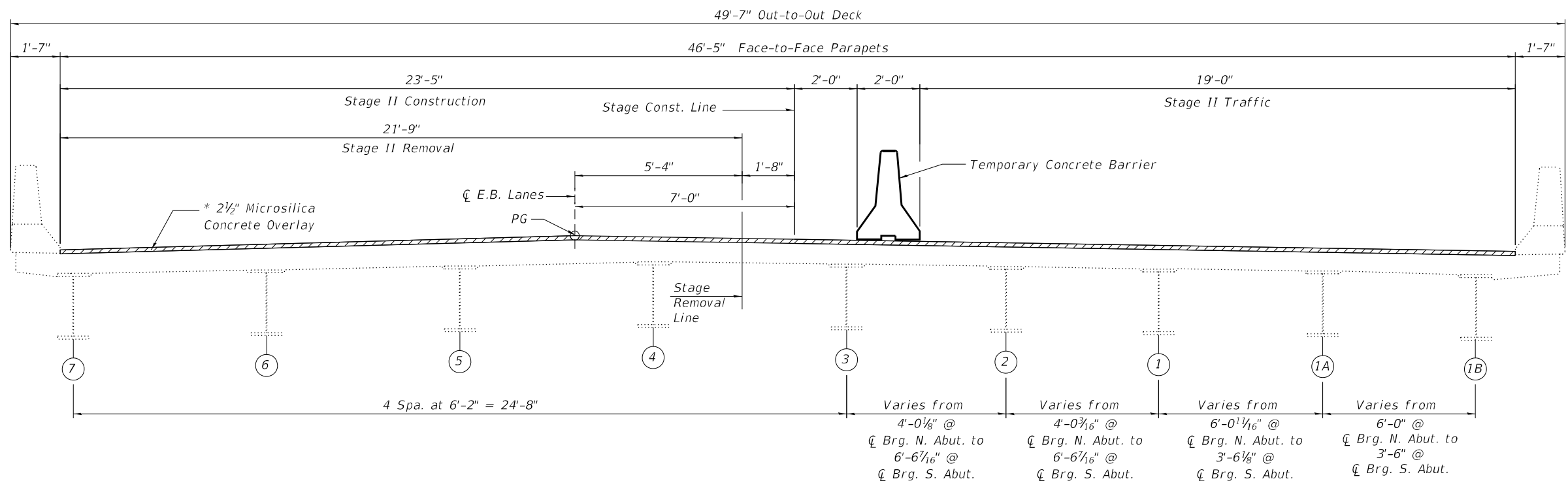

STAGE II CONSTRUCTION DETAILS
(Looking South)

* (Prior to 1/4" Diamond Grinding)



USER NAME =	DESIGNED - RBT	REVISIONS -
	CHECKED - MJH	REVISIONS -
PLOT SCALE =	DRAWN - RBT	REVISIONS -
PLOT DATE =	CHECKED - MJH	REVISIONS -

**STATE OF ILLINOIS
DEPARTMENT OF TRANSPORTATION**

**STAGE CONSTRUCTION DETAILS
S.N. 048-0007 (E.B.)**

SHEET 6 OF 34 SHEETS

F.A.I. RTE.	SECTION	COUNTY	TOTAL SHEETS	SHEET NO.
74	48[(26VB)BY, BY-1]BRR	KNOX	69	25
CONTRACT NO. 68D83				

ILLINOIS FED. AID PROJECT

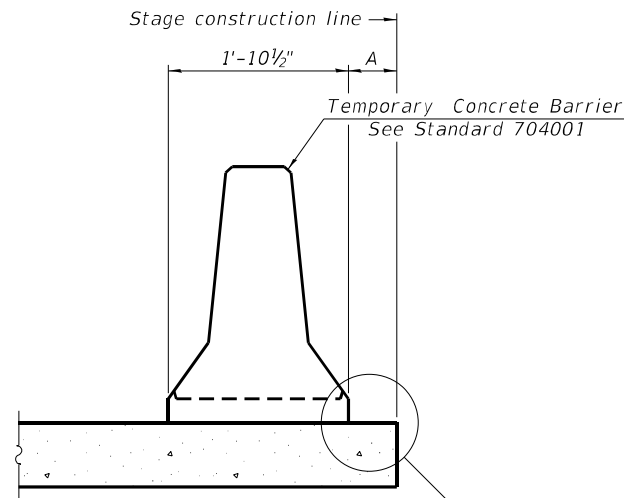

When "A" is 3'-1" or less, the temporary concrete barrier shall be restrained to the new slab according to Detail I, II or III. No restraint is required when "A" is greater than 3'-1".

NEW SLAB OR NEW DECK BEAM

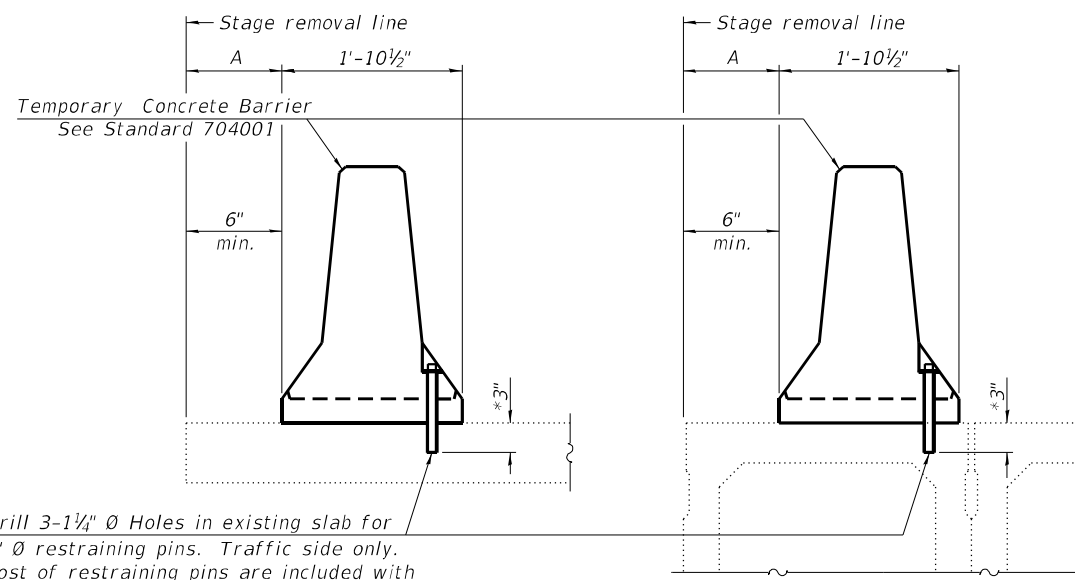

Drill 3-1/4" Ø Holes in existing slab for 1" Ø restraining pins. Traffic side only. Cost of restraining pins are included with Temporary Concrete Barrier. No restraint is required when "A" is greater than 3'-1".

EXISTING SLAB

* When hot-mix asphalt wearing surface is present, embedment shall be 3" plus the wearing surface depth.

EXISTING DECK BEAM

SECTIONS THRU SLAB OR DECK BEAM

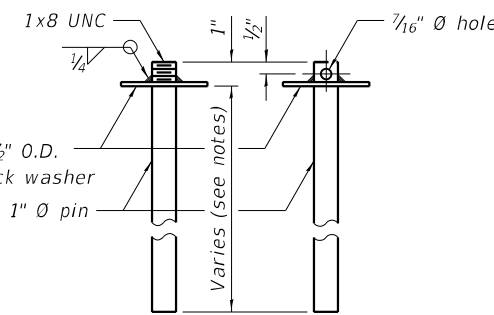

RESTRAINING PIN

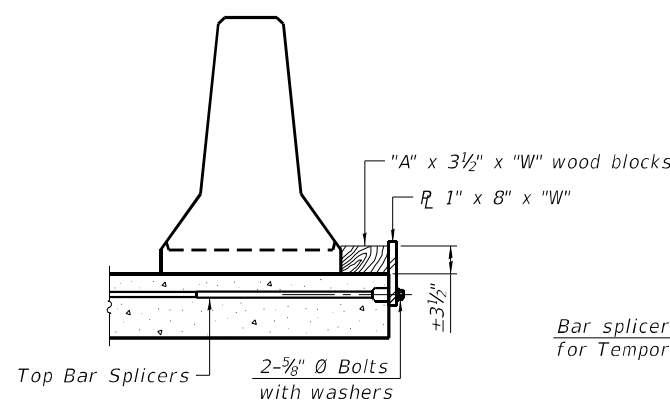

DETAIL I

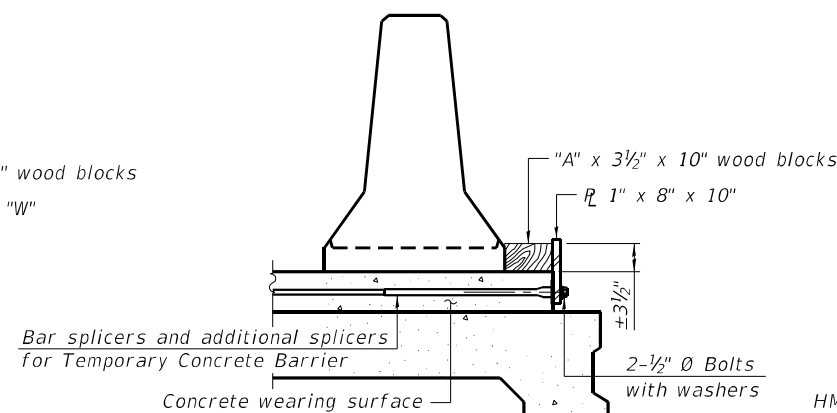

DETAIL II

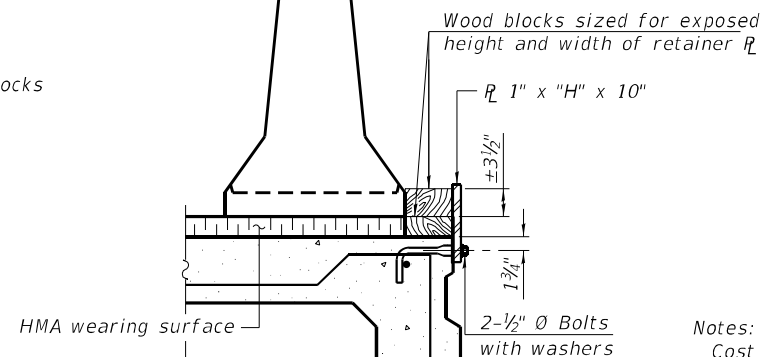

DETAIL III

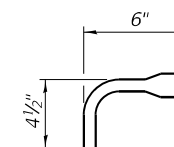

BAR SPLICER FOR #4 BAR - DETAIL III

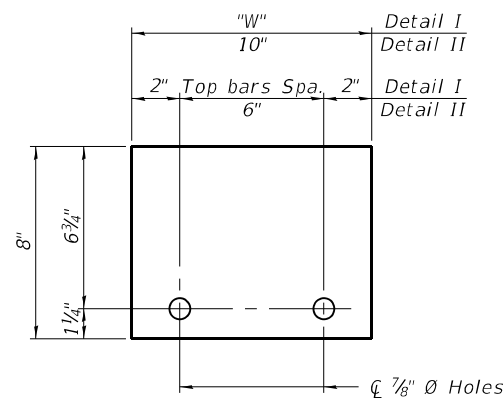

STEEL RETAINER R_L 1" x 8" x "W"
(Detail I and II)

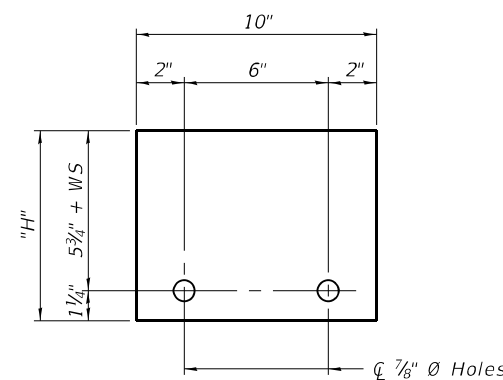

STEEL RETAINER R_L 1" x "H" x 10"
(Detail III)

Notes:
 Cost of retainer assembly is included with Temporary Concrete Barrier.
 A retainer assembly shall be located at the approximate $\frac{1}{2}$ of each temporary concrete barrier.
 The retainer plate shall not be removed until the concrete on the adjacent stage is ready to be poured. For Detail III applications the retainer plate shall not be removed until just prior to placing the adjacent beam.
 When the 'A' dimension is less than 1 1/2", the wood block shall be omitted and the barrier shall be placed in direct contact with the steel retainer plate. For deck beam applications the minimum required 'A' distance is 6" to accommodate the shear key clamping device.

Detail I - Installation for a new bridge deck or bridge slab.
 Detail II - Installation for a new deck beam with an initial concrete wearing surface. Additional bar splicers shall be provided at 6'-0" centers and paired with the bar splicers of the concrete wearing surface reinforcement to accommodate the installation of the retainer assemblies. The cost of the additional bar splicers is included with the concrete wearing surface.
 Detail III - Installation for a new deck beam with no initial wearing surface or with an initial hot-mix asphalt (HMA) wearing surface present. The deck beam directly beneath the temporary concrete barrier shall be fabricated with bar splicer inserts in the side of the beam, as detailed, to accommodate the installation of the retainer assemblies. A pair of bar splicers, 6" apart, shall be placed at 6'-0" centers along the length of the beam. The cost of the bar splicers is included with the deck beam.

RAILING CRITERIA

NCHRP 350 Test Level	3
Railing Weight (plf)	440

R-27 10-12-2021

MODEL: Default
 FILE NAME: P:\Effingham\4852 - IDOT RTE 198-018_D4_VV\Work Order #1017 Temporary Concrete Barrier.dgn
 10/19/2023 3:53:20 PM



USER NAME =	DESIGNED - RBT	REVISED -
PLOT SCALE =	CHECKED - MJH	REVISED -
PLOT DATE =	DRAWN - RBT	REVISED -
	CHECKED - MJH	REVISED -

STATE OF ILLINOIS
 DEPARTMENT OF TRANSPORTATION

TEMPORARY CONCRETE BARRIER
 S.N. 048-0008 (W.B.) & 048-0007 (E.B.)

SHEET 7 OF 34 SHEETS

F.A.I. RTE.	SECTION	COUNTY	TOTAL SHEETS	SHEET NO.
74	48([26VB]BY,BY-1]BRR	KNOX	69	26
			CONTRACT NO. 68D83	
ILLINOIS		FED. AID PROJECT		

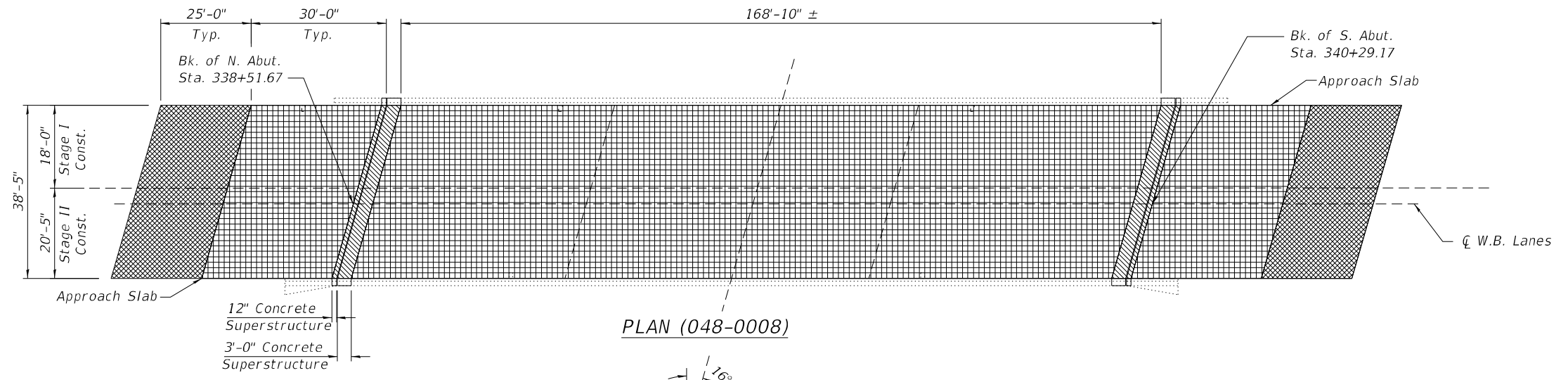
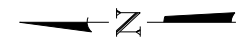

PLAN (048-0008)

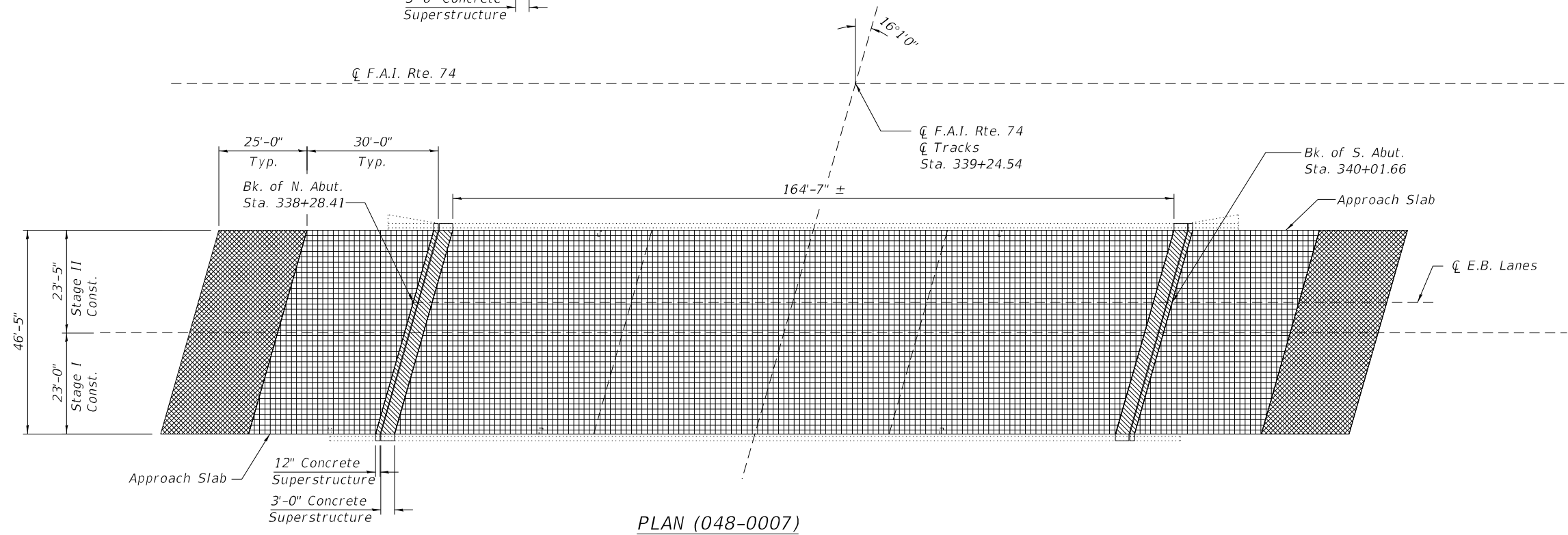

PLAN (048-0007)

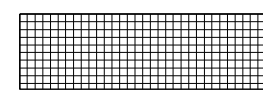

Bridge Deck Scarification, 3/4", Bridge Deck Microsilica Concrete Overlay, 2 1/2",
Diamond Grinding, 1/4" and Bridge Deck Grooving (Longitudinal).

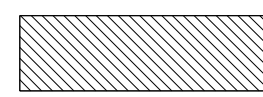

Diamond Grinding, 1/4" and Bridge Deck Grooving (Longitudinal).

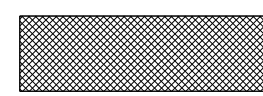

Diamond Grinding, 1/4"

BILL OF MATERIAL
(Deck & Approach)

Item	Unit	048-0008	048-0007	Total
Bridge Deck Scarification 3/4"	Sq. Yd.	967	1,146	2,113
Diamond Grinding (Bridge Section)	Sq. Yd.	1,091	1,324	2,415
Bridge Deck Microsilica Concrete Overlay 2 1/2"	Sq. Yd.	967	1,146	2,113
Bridge Deck Grooving (Longitudinal)	Sq. Yd.	628	925	1,553

MODEL: Default
FILE NAME: P:\Effingham\4852 - IDOT FTB 198-018_D4_VVAWork Order #101 Rehab WO 10 RT18 Wearing Surface 0008 0007.dgn
10/19/2023 3:54:44 PM



CIVIL DESIGN, INC.
WBE | DBE
EFFINGHAM, IL
LICENSE #184.003222

USER NAME =	DESIGNED - RBT	REVISIONS -
	CHECKED - MJH	REVISIONS -
PLOT SCALE =	DRAWN - RBT	REVISIONS -
PLOT DATE =	CHECKED - MJH	REVISIONS -

STATE OF ILLINOIS
DEPARTMENT OF TRANSPORTATION

WEARING SURFACE PLAN
S.N. 048-0008 (W.B.) & 048-0007 (E.B.)

SHEET 8 OF 34 SHEETS

F.A.I. RTE.	SECTION	COUNTY	TOTAL SHEETS	SHEET NO.
74	48[(26VB)BY,BY-1]BRR	KNOX	69	27
			CONTRACT NO. 68D83	
		ILLINOIS FED. AID PROJECT		

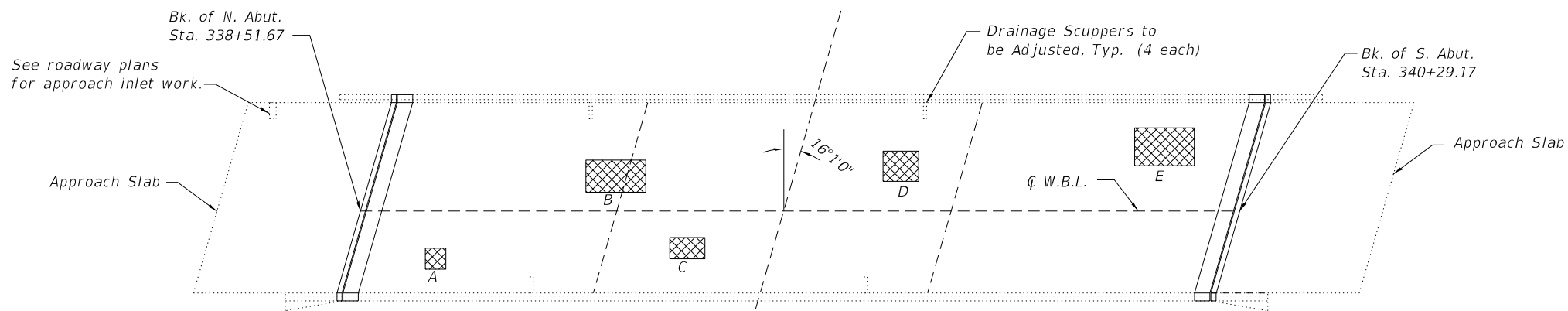
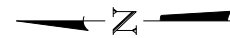

PLAN (048-0008)

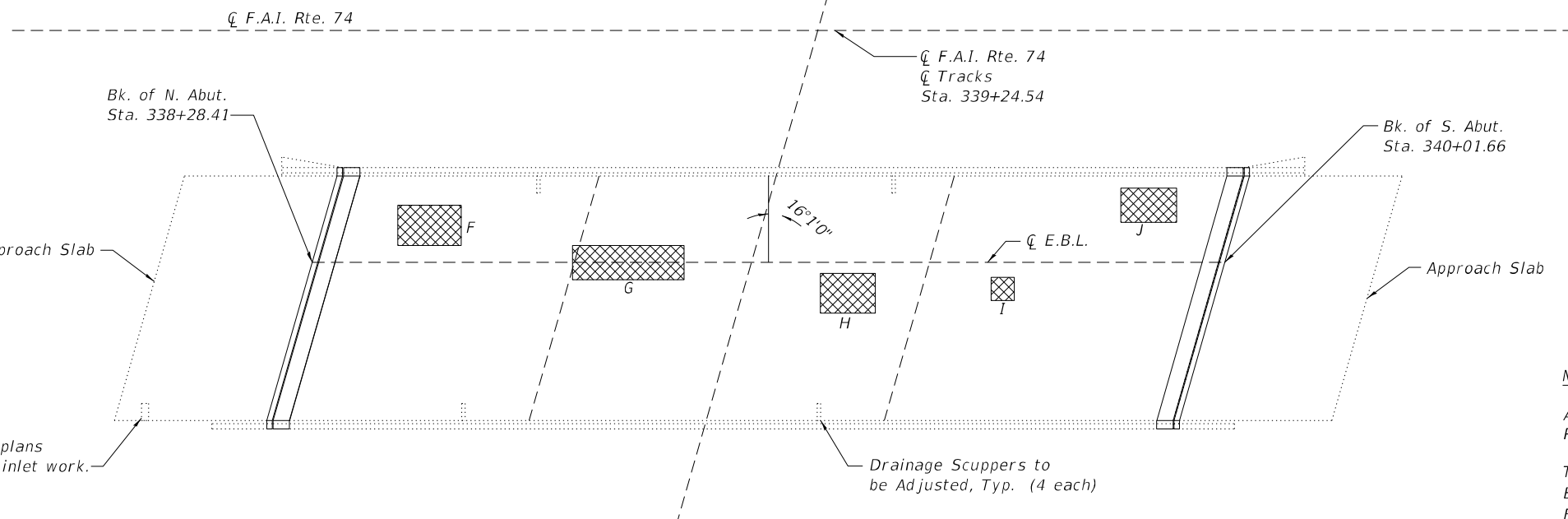

PLAN (048-0007)

Deck Slab Repair (Full Depth Type I)

NOTES:

An Estimated 3% of the Deck Area has been included should additional Deck Slab Repair (Full Depth, Type I) be required after Bridge Deck Scarification.

The actual sizes and locations of patching shall be determined by the Resident Engineer after 3/4" Concrete Removal before patching operations begin. The Engineer shall show the actual locations of deck repairs on As-Built plans.

Extreme care must be used when removing concrete near the top flange of the beams. The Contractor is responsible for any damage to the beams.

**Deck Slab Repair (Full Depth Type I)
048-0008, 048-0007**

Number	Length (ft)	Width (ft)	Area Sq. Yd.
A	5	5	2.8
B	8.5	7	6.6
C	6	7	4.7
D	5	5	2.8
E	7	7	5.4
F	7	7	5.4
G	8	6	5.3
H	8	8	7.1
I	5	5	2.8
J	7.5	7	5.8

BILL OF MATERIAL

Item	Unit	048-0008	048-0007	Total
Drainage Scuppers to be Adjusted	Each	4	4	8
Deck Slab Repair (Full Depth, Type I)	Sq. Yd.	22.3	26.5	48.8

MODEL: Default
FILE NAME: P:\Effingham\4852 - IDOT FTB 198-018_D4_VVA\Work Order #10\Rehab WO 10 RT19 Deck Slab Repair Plan 0008_0007.dgn



CIVIL DESIGN, INC.
WBE | DBE
EFFINGHAM, IL
LICENSE # 184.003222

USER NAME =	DESIGNED - RBT	REVISED -
	CHECKED - MJH	REVISED -
PLOT SCALE =	DRAWN - RBT	REVISED -
PLOT DATE =	CHECKED - MJH	REVISED -

STATE OF ILLINOIS
DEPARTMENT OF TRANSPORTATION

DECK SLAB REPAIR PLAN
S.N. 048-0008 (W.B.) & 048-0007 (E.B.)

SHEET 9 OF 34 SHEETS

F.A.I. RTE.	SECTION	COUNTY	TOTAL SHEETS	SHEET NO.
74	48[(26VB)BY,BY-1]BRR	KNOX	69	28
			CONTRACT NO. 68D83	
		ILLINOIS FED. AID PROJECT		

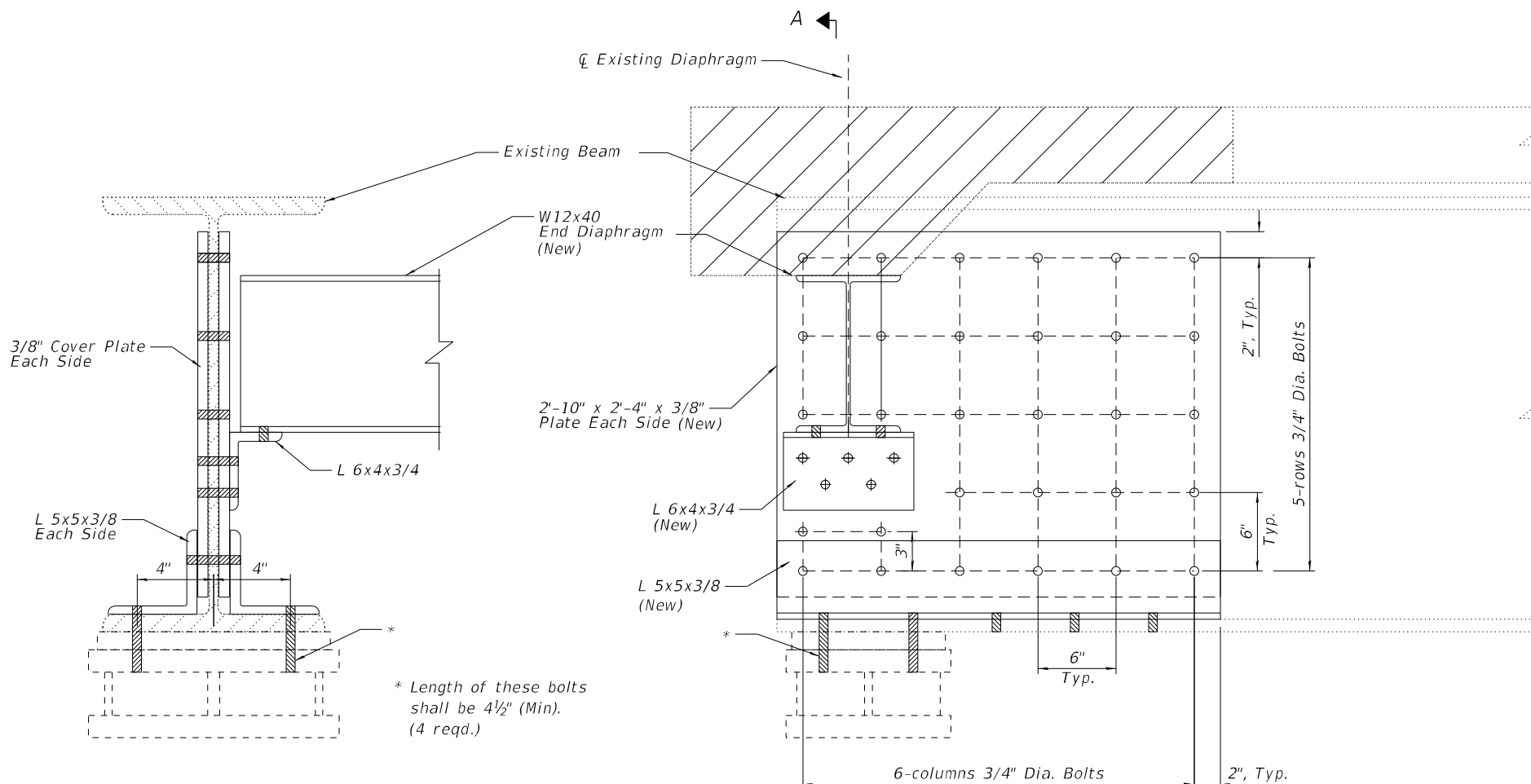

SECTION A-A

* Length of these bolts shall be 4 1/2" (Min). (4 reqd.)

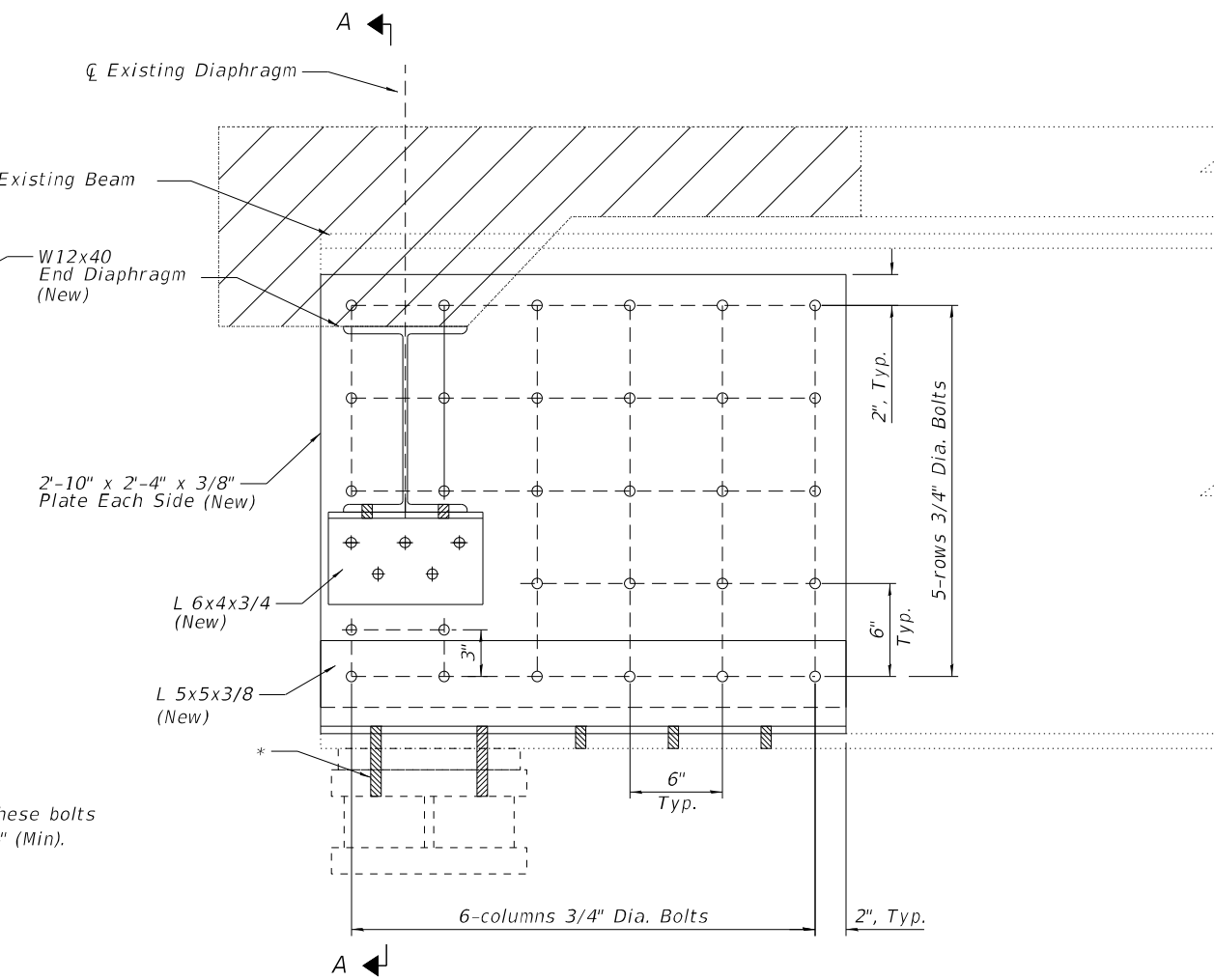

BEAM WEB REPAIR DETAIL
(Beam 7 at N. Abutment of 048-0007)

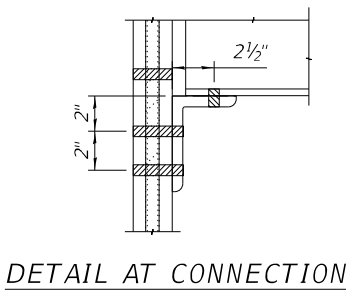

DETAIL AT CONNECTION

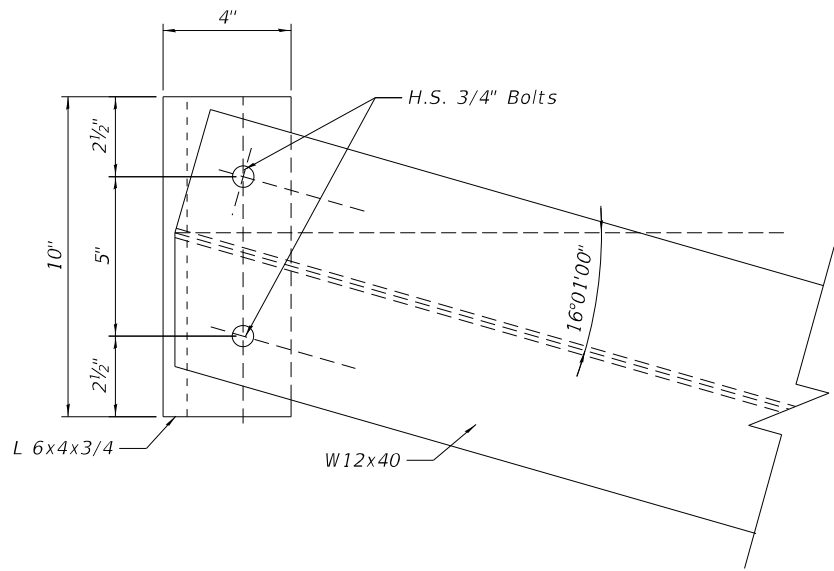

End Diaphragm Angle Plan

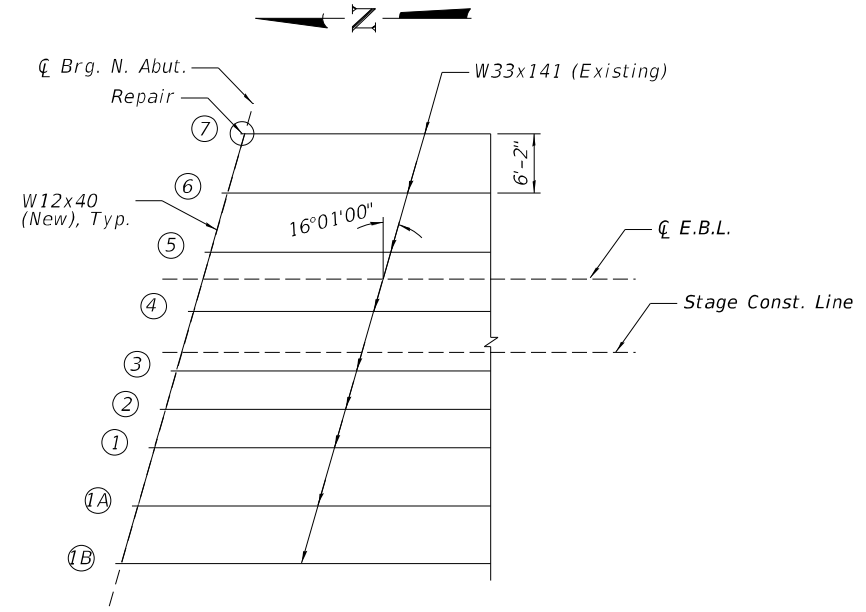

FRAMING PLAN
(Partial)

BILL OF MATERIAL

Item	Unit	Total
Structural Steel Removal	Pound	280
** Furnishing and Erecting Structural Steel	Pound	360
*** Structural Steel Repair	Pound	210

** New diaphragm and clip angles.
*** Web and bottom flange plates.

Notes:
All new fasteners shall be high strength bolts. Holes shall be 13/16" dia. for 3/4" dia. bolts, unless otherwise noted.
Use holes in new steel as template to field drill holes in existing steel.
Use holes in existing steel to remain as template to field drill holes in new steel.
Cost of field drilling shall be included with the cost of structural steel work being performed.
Holes in bottom flange of new end diaphragm shall be field drilled using existing holes in angle support as a template. The cost of field drilling shall be included in Furnishing and Erecting Structural Steel.
Existing end diaphragm and angle at exterior girder shall be replaced.
All structural steel shall conform to AASHTO Classification M-270 GR. 36, unless otherwise noted.
Existing structural steel that will be in contact with new structural steel shall be cleaned and painted prior to erection as required by special provision "Cleaning and Painting Contact Surface Areas of Existing Steel Structures"

MODEL: Default
FILE NAME: P:\Effingham\4852 - IDOT FTB 198-018_D4_VVAWork Order #10V Rehab WO 10 RT10 Beam End Strengthening 0007.dgn
10/19/2023 3:55:08 PM



CIVIL DESIGN, INC.
WBE / DBE
EFFINGHAM, IL
LICENSE #184.003222

USER NAME	DESIGNED	REVISIONS
RBT	RBT	
MJH	MJH	
RBT	RBT	
MJH	MJH	

STATE OF ILLINOIS
DEPARTMENT OF TRANSPORTATION

BEAM END STRENGTHENING
S.N. 048-0007 (E.B.)

SHEET 10 OF 34 SHEETS

F.A.I. RTE.	SECTION	COUNTY	TOTAL SHEETS	SHEET NO.
74	48[(26VB)BY,BY-1]BR	KNOX	69	29
CONTRACT NO. 68D83				
ILLINOIS FED. AID PROJECT				

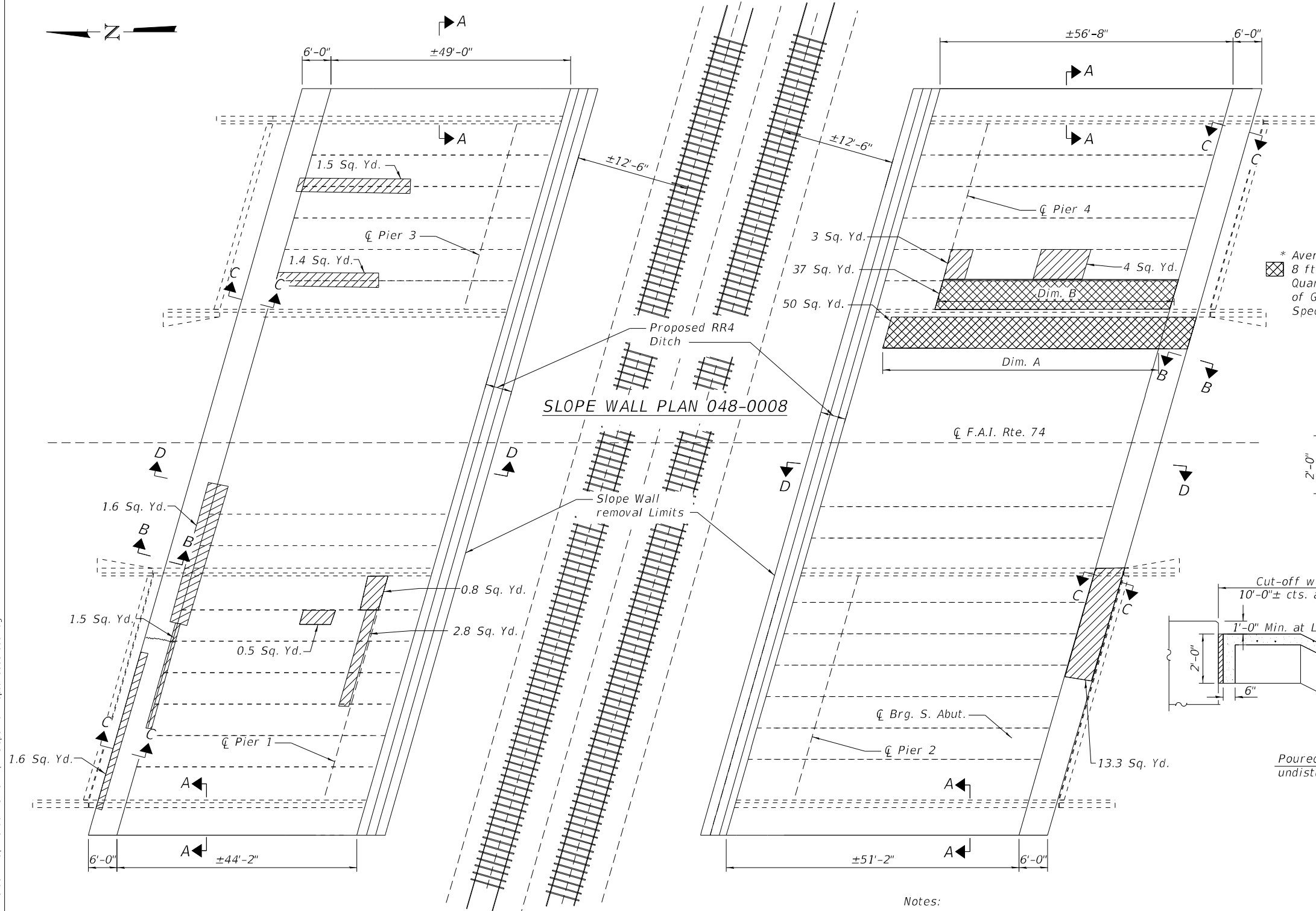
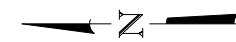

SLOPE WALL PLAN 048-0008

SLOPE WALL PLAN 048-0007

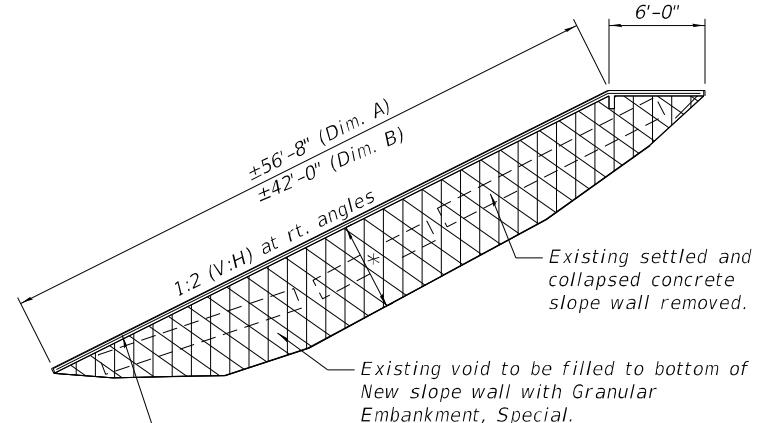

SLOPE WALL FILL DETAIL

* Average Fill depth of 8 ft. is considered for Quantity Calculation of Granular Embankment, Special.

Slope wall shall be reinforced with welded wire fabric (WWF) 6x6 galvanized-W4xW4, weighing 58 lbs per 100 sq. ft. Lap 6" min. to existing WWF.

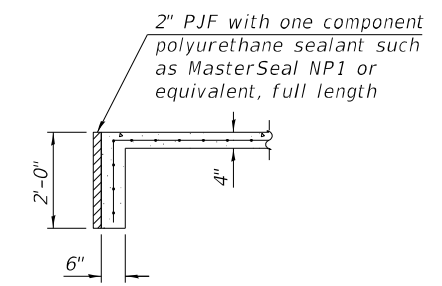

SECTION C-C

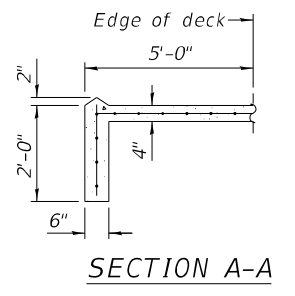

SECTION A-A

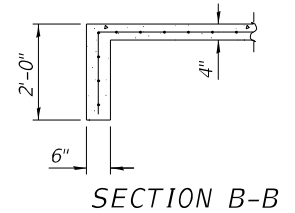

SECTION B-B

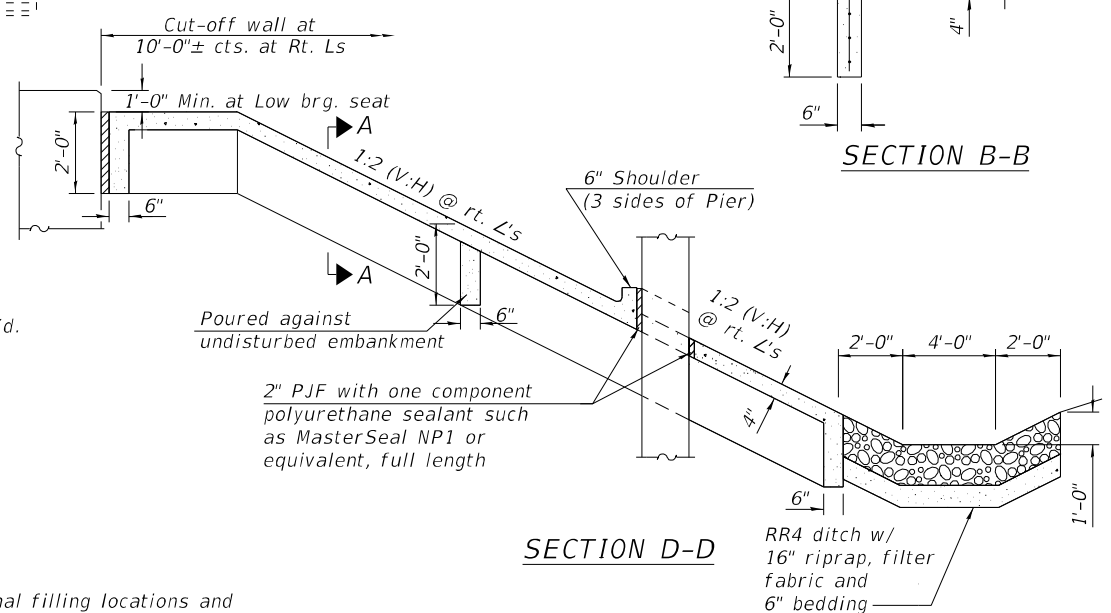

SECTION D-D

BILL OF MATERIAL

Item	Unit	048-0008	048-0007	Total
Stone Riprap, Class B4	Ton	125	148	273
Filter Fabric	Sq. Yd.	125	150	275
Slope Wall Removal	Sq. Yd.	1,191	1,218	2,409
Slope Wall 4 Inch	Sq. Yd.	1,050	1,062	2,112

Notes:

The Resident Engineer will determine final filling locations and quantities in the field before slope wall construction operations begin.

All material and debris in gutter at bottom of slope wall to be removed. Additionally, existing CLSM under slope wall panels may need removed or graded. Cost included with Slope Wall Removal.

Quantities and limits shown are estimated for bidding purposes only. The actual areas to be repaired and the type(s) to be used, will be determined by engineer in the field at the time of construction.

Slope wall shall be reinforced with welded wire fabric, 6 in x 6 in galvanized - W4.0 x W4.0 weighing 58 lbs per 100 sq. ft.

- Slope wall remove and replacement anticipated sequence of construction:
1. Remove all of concrete slope wall, including exist. paved ditch.
 2. Fill subgrade voids of the proposed slope wall replacement with Granular Embankment, Special level and compact.
 3. Install proposed Slope Wall 4 Inch.

Indicates estimated areas of slope wall that requires to be filled by Granular Embankment, Special. Avg. fill depth is 1'.

MODEL: Default
FILE NAME: P:\Effingham\4852 - IDOT FTB 198-018_D4_VVA\Work Order #10\Rehab WO 10 RT11 Slope wall Repair_0008_0007.dgn
10/19/2023 3:55:10 PM



CIVIL DESIGN, INC.
WBE / DBE
EFFINGHAM, IL
LICENSE #184.003222

USER NAME	DESIGNED	REVISIONS
RBT	RBT	
MJH	MJH	
RBT	RBT	
MJH	MJH	

STATE OF ILLINOIS
DEPARTMENT OF TRANSPORTATION

SLOPE WALL REMOVE AND REPLACE
S.N. 048-0008 (W.B.) S.N. 048-0007 (E.B.)

SHEET 11 OF 34 SHEETS

F.A.I. RTE.	SECTION	COUNTY	TOTAL SHEETS	SHEET NO.
74	48[(26VB)BY.BY-1]BR	KNOX	69	30

CONTRACT NO. 68D83
ILLINOIS FED. AID PROJECT

MODEL: Default
 FILE NAME: P:\Effingham\4852 - IDOT FTB 198-018_D4_VVAWork Order #10Y Rehab WO 10 RT12 Substructure Repair 0008 0007.dgn
 10/19/2023 3:55:19 PM

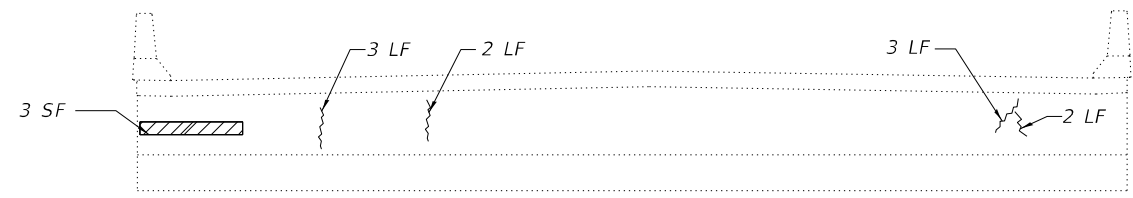

NORTH ELEVATION
(048-0008)

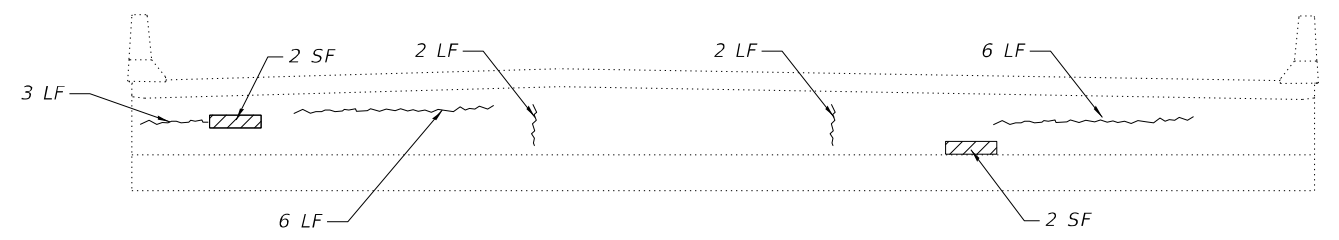

NORTH ELEVATION
(048-0007)



NORTH WING WALLS

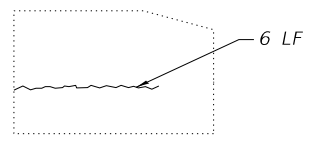

NORTH WING WALLS

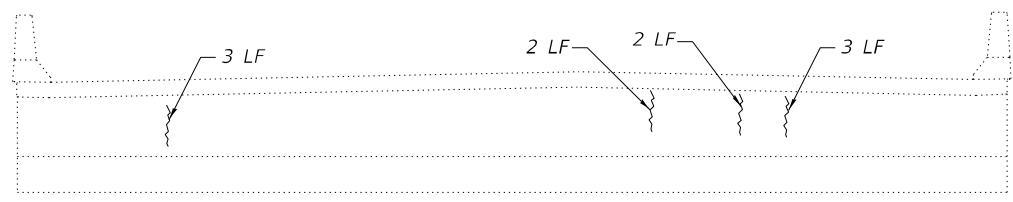
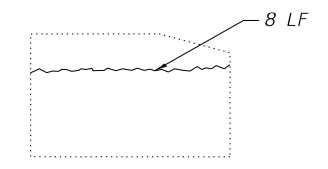

SOUTH ELEVATION
(048-0008)

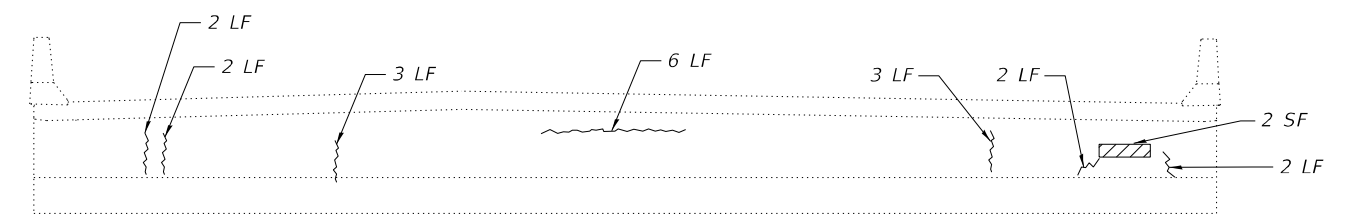

SOUTH ELEVATION
(048-0007)

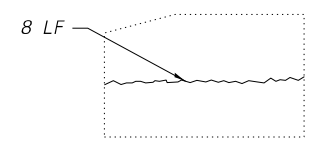

SOUTH WING WALLS

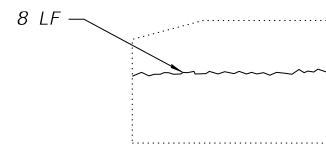

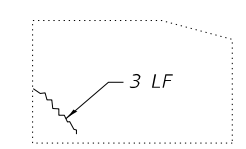

SOUTH WING WALLS



BILL OF MATERIAL

Structure	Item	Unit	Total
048-0008	Structural Repair of Concrete (Depth Equal to or Less than 5 inches)	Sq. Ft.	3
048-0008	Epoxy Crack Injection	Foot	34
048-0007	Structural Repair of Concrete (Depth Equal to or Less than 5 inches)	Sq. Ft.	6
048-0007	Epoxy Crack Injection	Foot	58

 Structural Repair of Concrete
(Depth Equal to or Less than 5 inches)

 Epoxy Crack Injection



CIVIL DESIGN, INC.
 WBE / DBE
 EFFINGHAM, IL
 LICENSE # 184.003222

USER NAME =	DESIGNED - RBT	REVISED -
	CHECKED - MJH	REVISED -
PLOT SCALE =	DRAWN - RBT	REVISED -
PLOT DATE =	CHECKED - MJH	REVISED -

STATE OF ILLINOIS
DEPARTMENT OF TRANSPORTATION

SUBSTRUCTURE REPAIR
S.N. 048-0008 (W.B.) S.N. 048-0007 (E.B.)

SHEET 12 OF 34 SHEETS

F.A.I. RTE.	SECTION	COUNTY	TOTAL SHEETS	SHEET NO.
74	48[(26VB)BY, BY-1]BRR	KNOX	69	31
			CONTRACT NO. 68D83	
ILLINOIS FED. AID PROJECT				

MODEL: Default
 FILE NAME: P:\Effingham\4852 - IDOT FTB 198-018_D4_VVAWork Order #10\Rehab WO 10 RT13 Superstructure Plan - Concrete Removal 0008.dgn
 10/19/2023 3:55:20 PM

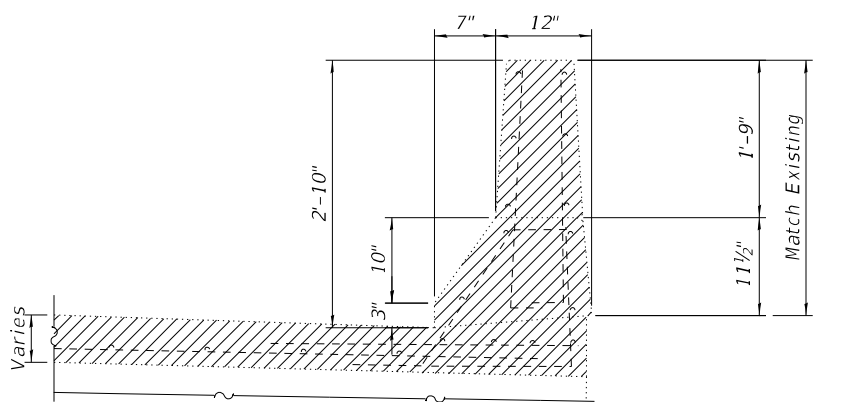
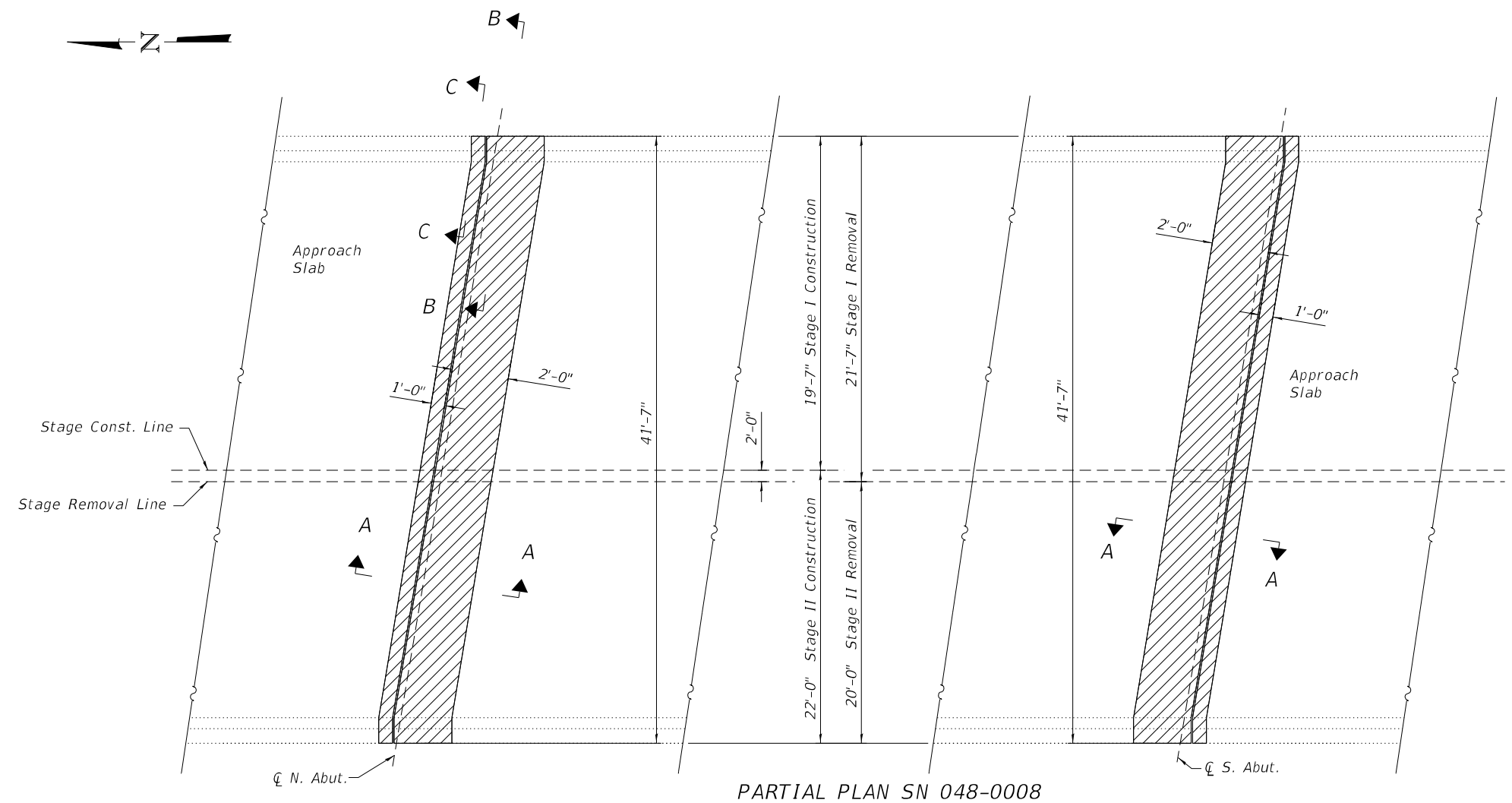

SECTION C-C

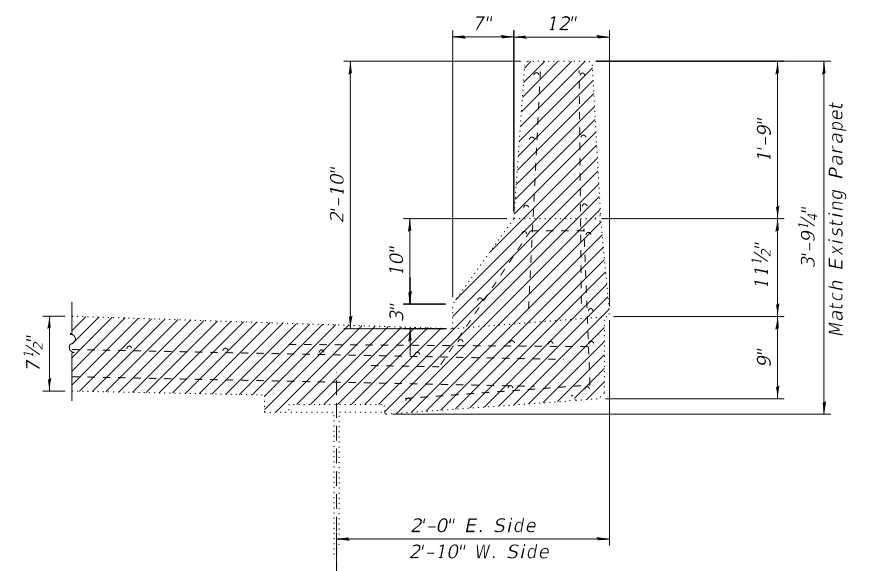

SECTION B-B

Indicates areas of concrete to be removed and replaced

NOTES:

Existing longitudinal reinforcement extending into the removal area shall be cleaned, straightened and incorporated into the new construction. Any reinforcement bars that are damaged during concrete removal, existing vertical reinforcement and existing transverse reinforcement shall be replaced using an approved bar splicer or anchorage system. Cost included with Concrete Removal.

The existing expansion joint system shall be removed completely, as well as any foreign material that has accumulated or been placed in the joint openings. The cost for this work is included in Concrete Removal and no additional compensation will be allowed.

For Deck Reinforcement Details, see Sheet 13 of 33.

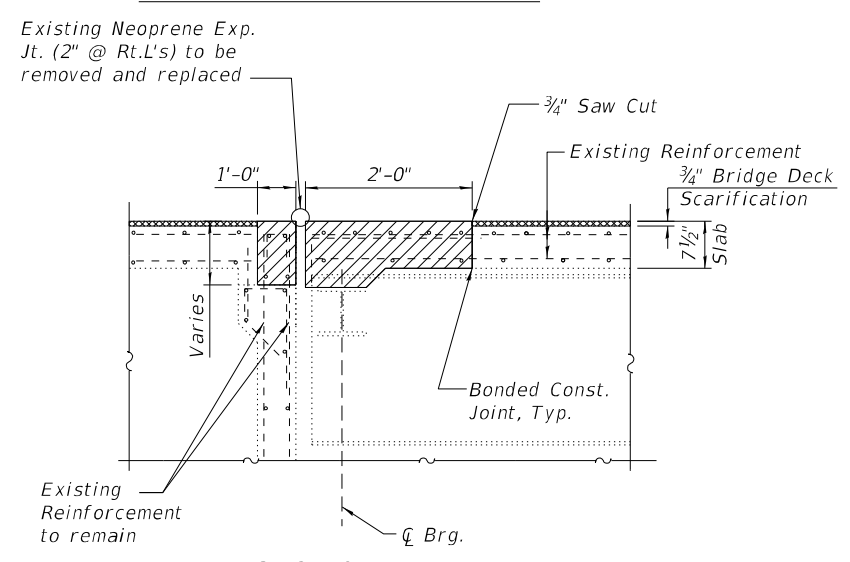

SECTION A-A

TYPICAL SECTION THRU. ABUTMENT

BILL OF MATERIAL

Structure	Item	Unit	Total
048-0008	Concrete Removal	Cu. Yd.	10.6



CIVIL DESIGN, INC.
 WBE / DBE
 EFFINGHAM, IL
 LICENSE #184.003222

USER NAME =	DESIGNED - RBT	REVISED -
	CHECKED - MJH	REVISED -
PLOT SCALE =	DRAWN - RBT	REVISED -
PLOT DATE =	CHECKED - MJH	REVISED -

STATE OF ILLINOIS
 DEPARTMENT OF TRANSPORTATION

SUPERSTRUCTURE REPAIR PLAN - CONCRETE REMOVAL DETAILS
 S.N. 048-0008 (W.B.)

SHEET 13 OF 34 SHEETS

F.A.I. RTE.	SECTION	COUNTY	TOTAL SHEETS	SHEET NO.
74	48[(26VB)BY, BY-1]BRB	KNOX	69	32
CONTRACT NO. 68D83			ILLINOIS FED. AID PROJECT	

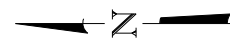

Note:
Any Reinforcement bars that are damaged during concrete removal operations shall be repaired or replaced using approved bar splicer or anchorage system. Cost included with Concrete Removal.

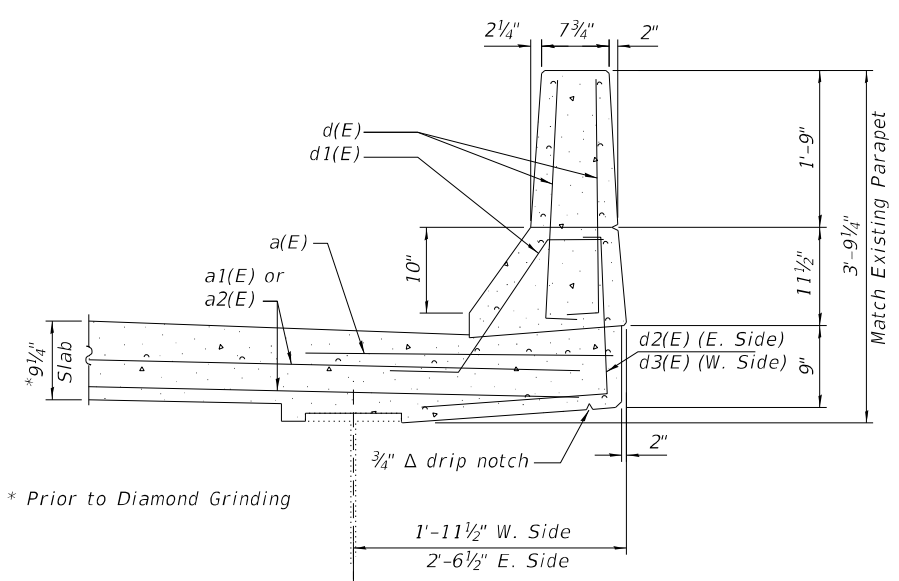
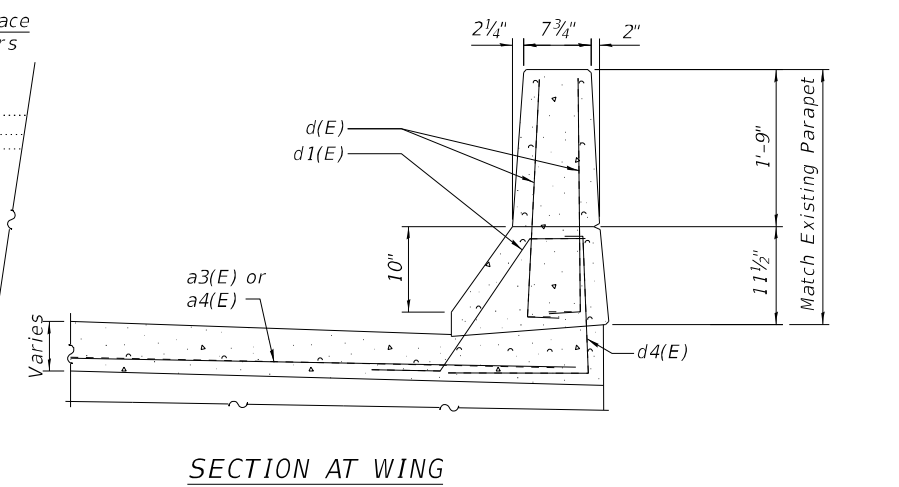
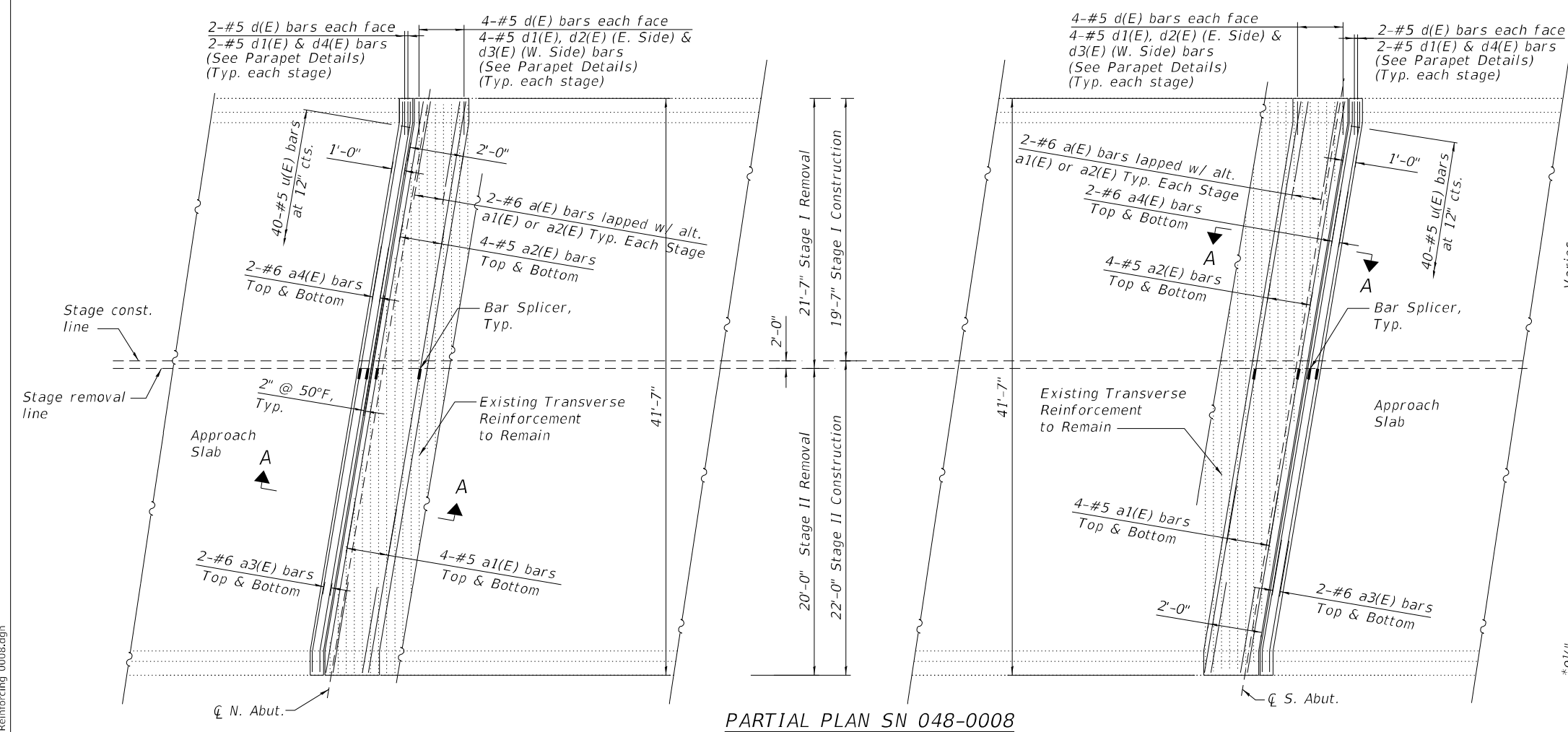

SECTION AT PARAPET

BILL OF MATERIAL

Bar	No.	Size	Length	Shape	
a(E)	8	#6	4'-0"	—	
a1(E)	16	#5	20'-11"	—	
a2(E)	16	#5	21'-4"	—	
a3(E)	8	#6	20'-11"	—	
a4(E)	8	#6	21'-4"	—	
d(E)	48	#5	3'-0"	—	
d1(E)	24	#5	2'-7"	✓	
d2(E)	8	#4	3'-7"]	
d3(E)	8	#4	3'-0"]	
d4(E)	8	#4	3'-7"]	
u(E)	80	#5	2'-9"	□	
Reinforcement Bars, Epoxy Coated				Pound	1,760
Concrete Superstructure				Cu. Yd.	12.8

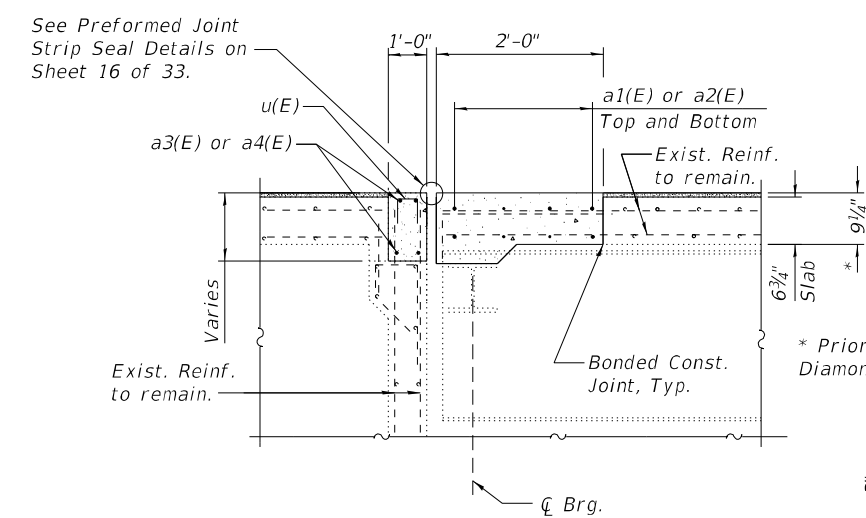

SECTION A-A
TYPICAL SECTION THRU. ABUTMENT

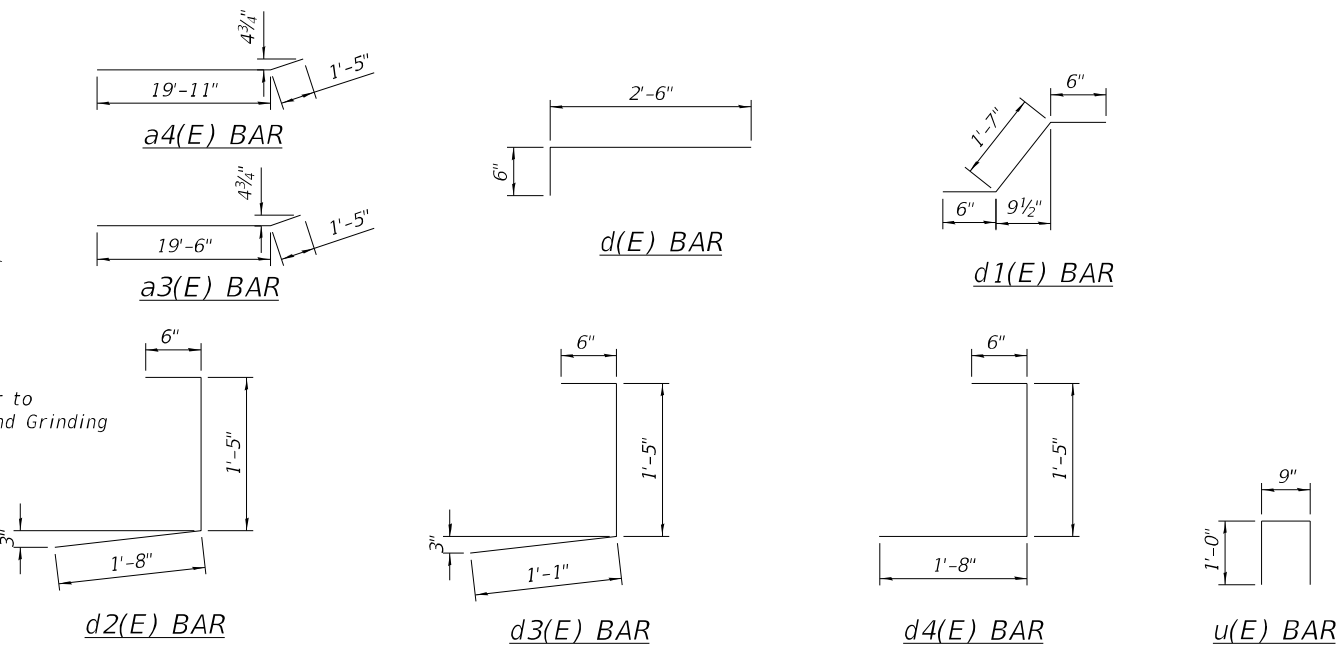

MODEL: Default
FILE NAME: P:\Effingham\4852 - IDOT FTB 198-018_D4_VVAWork Order #107 Rehab WO 10 RT14 Superstructure Plan - Deck Reinforcing 0008.dgn
10/19/2023 3:55:24 PM



USER NAME =	DESIGNED - RBT	REVISED -
PLOT SCALE =	CHECKED - MJH	REVISED -
PLOT DATE =	DRAWN - RBT	REVISED -
	CHECKED - MJH	REVISED -

STATE OF ILLINOIS
DEPARTMENT OF TRANSPORTATION

SUPERSTRUCTURE REPAIR PLAN - DECK REINFORCEMENT DETAILS
S.N. 048-0008 (W.B.)

F.A.I. R.T.E. = 74	SECTION = 48[(26VB)BY.BY-1]BR	COUNTY = KNOX	TOTAL SHEETS = 69	SHEET NO. = 33
			CONTRACT NO. 68D83	
ILLINOIS FED. AID PROJECT				

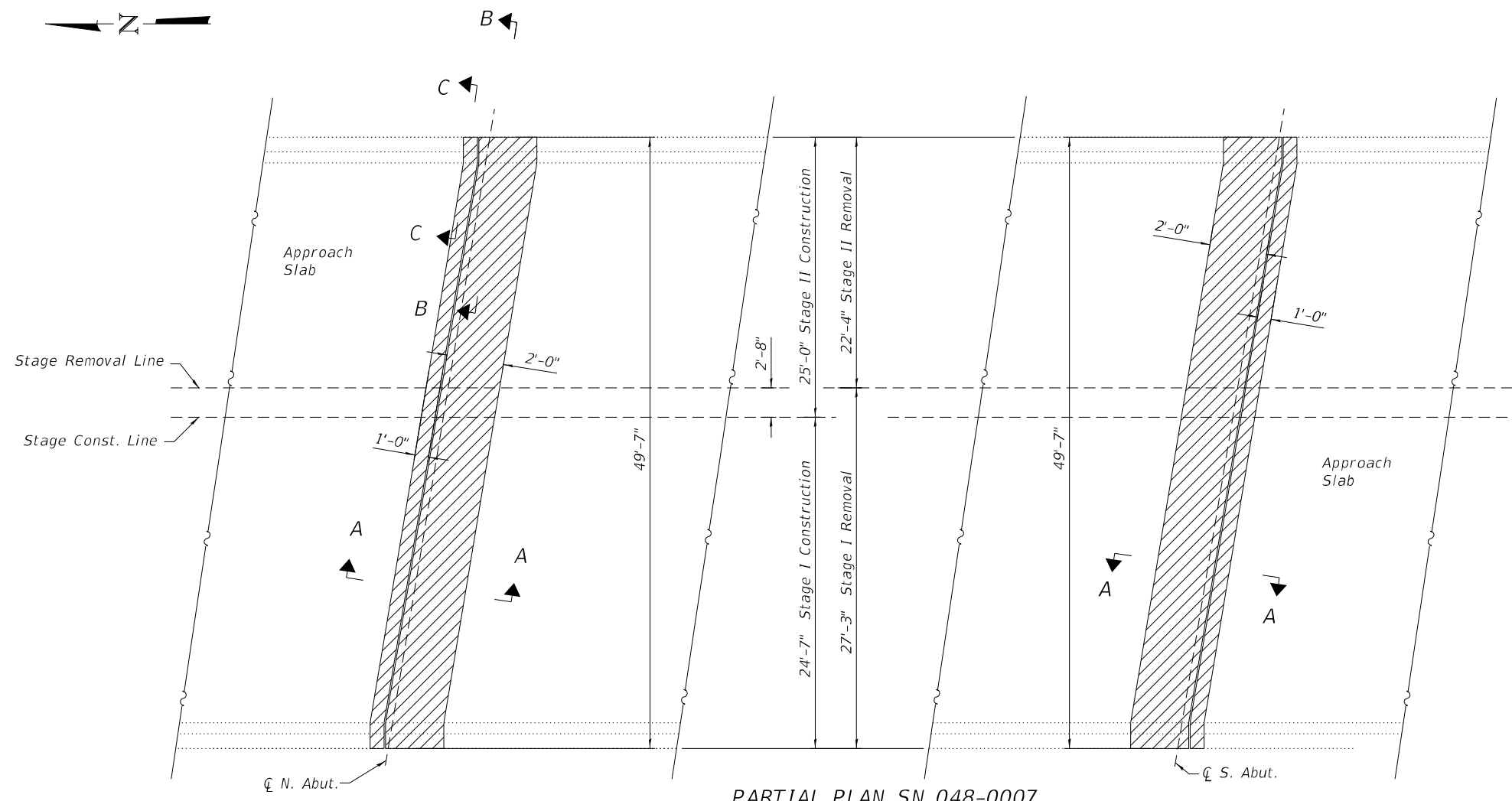
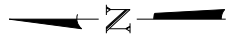

PARTIAL PLAN SN 048-0007

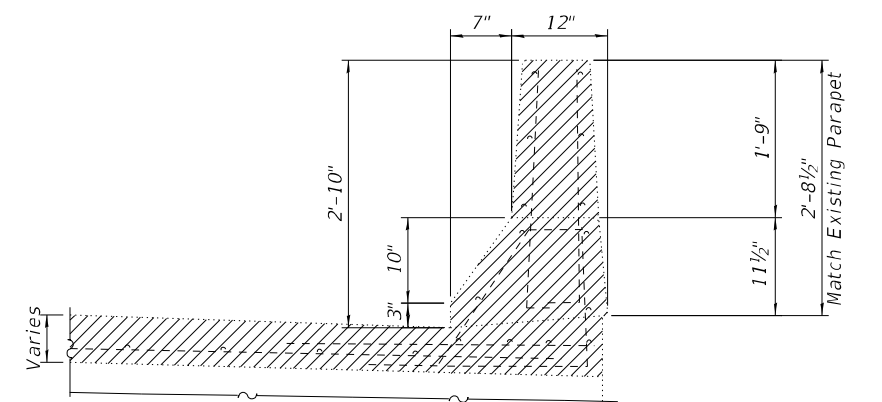

SECTION C-C

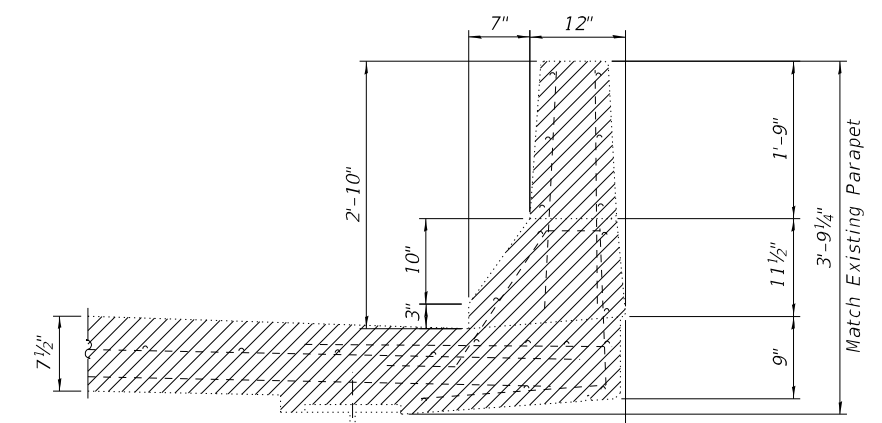

SECTION B-B

Indicates areas of concrete to be removed and replaced

NOTES:

Existing longitudinal reinforcement extending into the removal area shall be cleaned, straightened and incorporated into the new construction. Any reinforcement bars that are damaged during concrete removal, existing vertical reinforcement and existing transverse reinforcement shall be replaced using an approved bar splicer or anchorage system. Cost included with Concrete Removal.

The existing expansion joint system shall be removed completely, as well as any foreign material that has accumulated or been placed in the joint openings. The cost for this work is included in Concrete Removal and no additional compensation will be allowed.

For Deck Reinforcement Details, see Sheet 15 of 33.

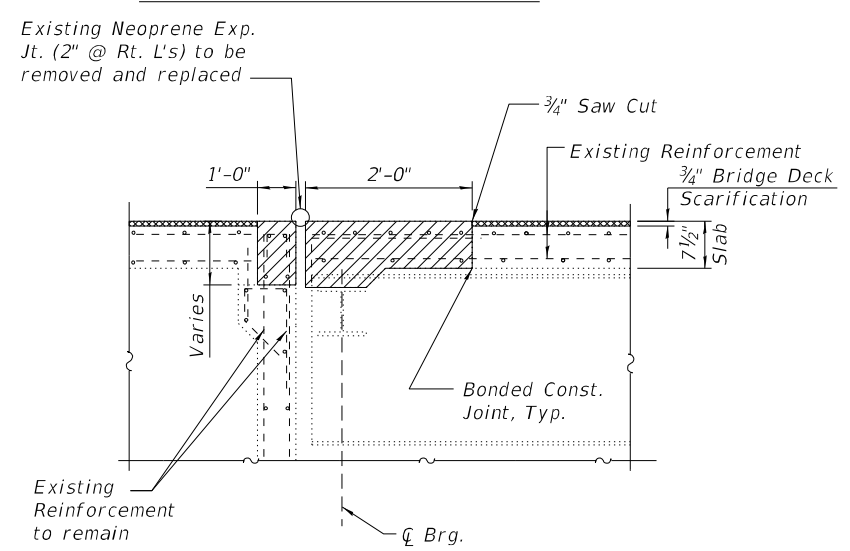

SECTION A-A
TYPICAL SECTION THRU. ABUTMENT

BILL OF MATERIAL

Structure	Item	Unit	Total
048-0007	Concrete Removal	Cu. Yd.	13.2

MODEL: Default
FILE NAME: P:\Effingham\4852 - IDOT FTB 198-018_D4_VVA\Work Order #10\RT15 Superstructure Plan - Concrete Removal - 0007.dgn



CIVIL DESIGN, INC.
WBE / DBE
EFFINGHAM, IL
LICENSE #184.003222

USER NAME =	DESIGNED - RBT	REVISED -
	CHECKED - MJH	REVISED -
PLOT SCALE =	DRAWN - RBT	REVISED -
PLOT DATE =	CHECKED - MJH	REVISED -

STATE OF ILLINOIS
DEPARTMENT OF TRANSPORTATION

SUPERSTRUCTURE REPAIR PLAN - CONCRETE REMOVAL DETAILS
S.N. 048-0007 (E.B.)

SHEET 15 OF 34 SHEETS

F.A.I. RTE.	SECTION	COUNTY	TOTAL SHEETS	SHEET NO.
74	48[(26VB)BY,BY-1]BRB	KNOX	69	34
			CONTRACT NO. 68D83	
ILLINOIS FED. AID PROJECT				

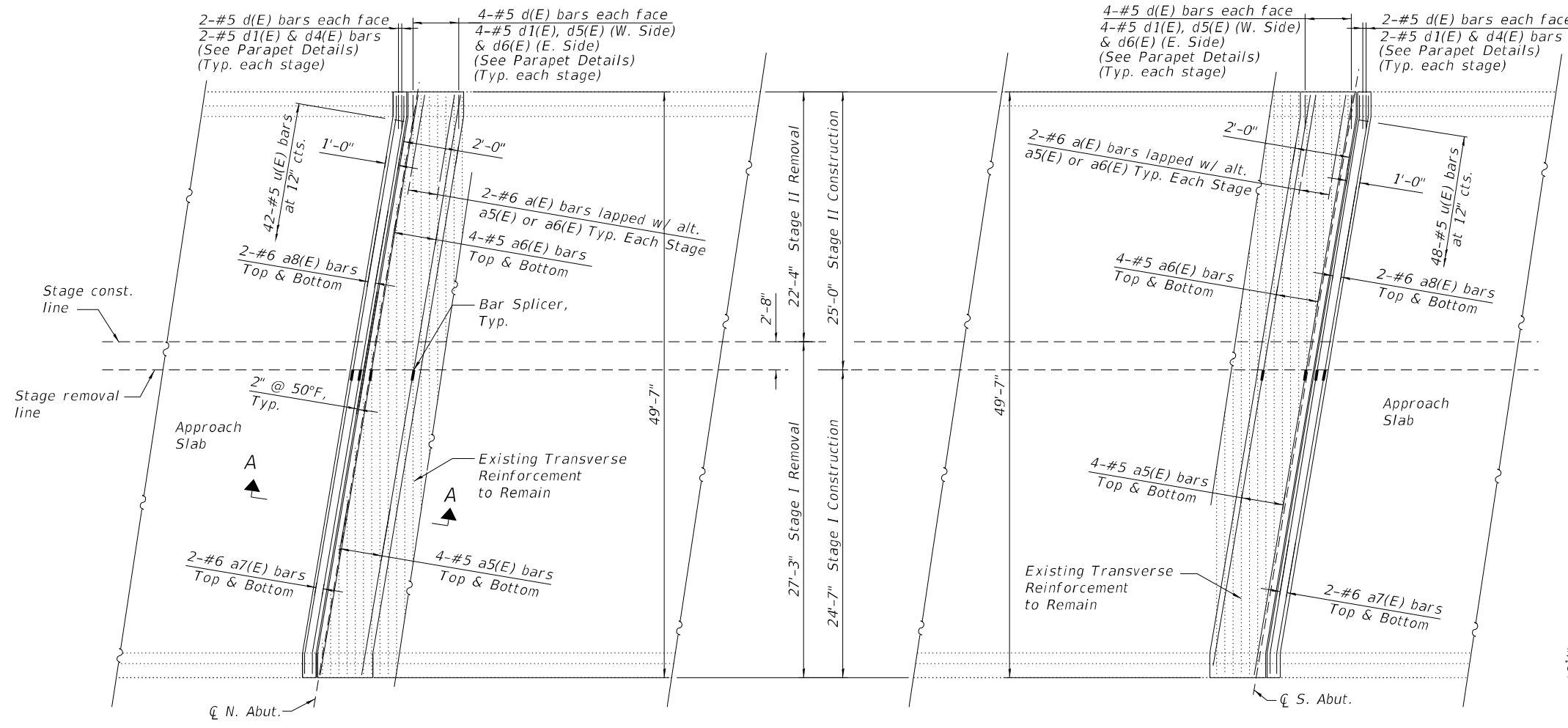
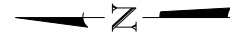

PARTIAL PLAN SN 048-0007

Note:
Any reinforcement bars that are damaged during concrete removal operations shall be repaired or replaced using approved bar splicer or anchorage system. Cost included with Concrete Removal.

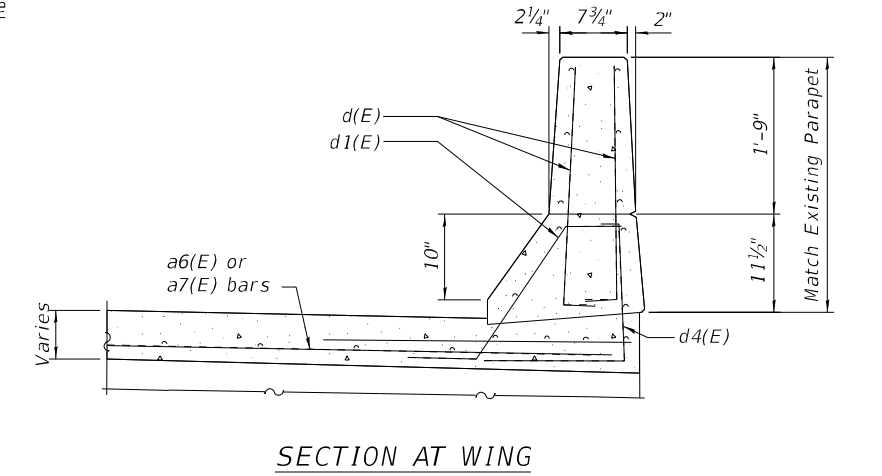

SECTION AT WING

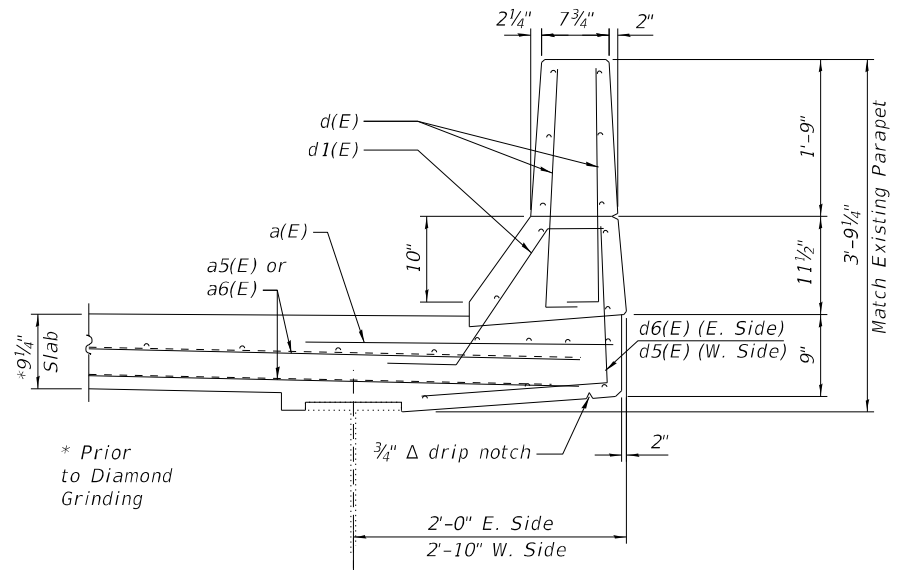

SECTION AT PARAPET

* Prior to Diamond Grinding

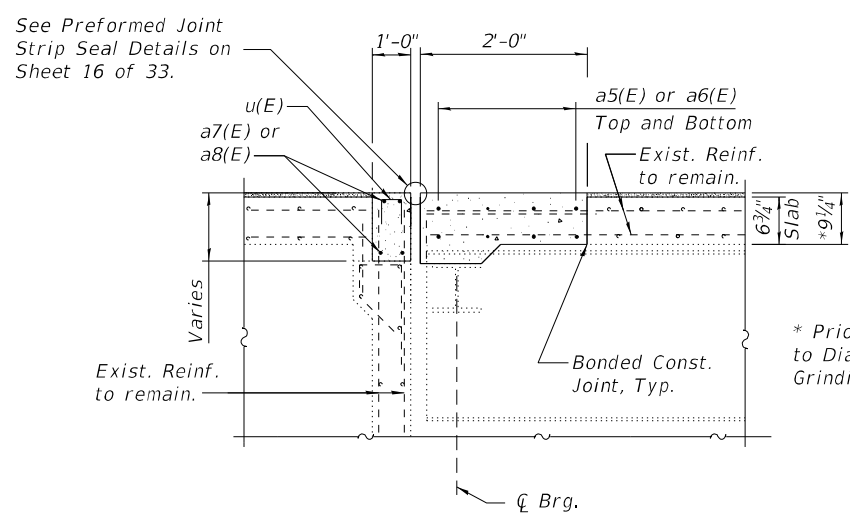

SECTION A-A

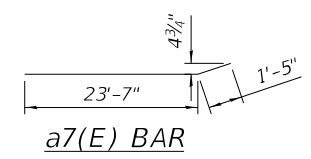

a7(E) BAR

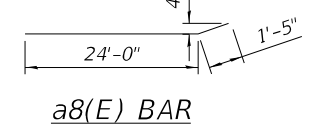

a8(E) BAR

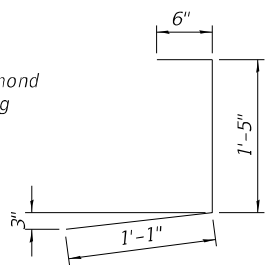

d6(E) BAR

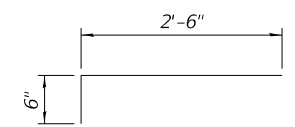

d(E) BAR

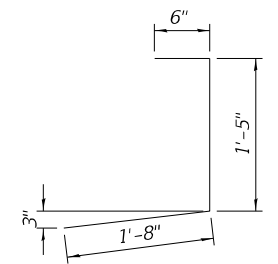

d5(E) BAR

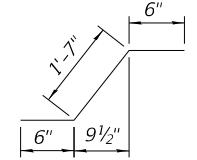

d1(E) BAR

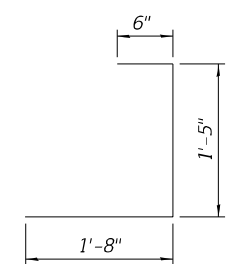

d4(E) BAR

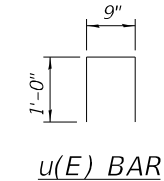

u(E) BAR

BILL OF MATERIAL

Bar	No.	Size	Length	Shape
a(E)	8	#6	4'-0"	—
a5(E)	16	#5	25'-0"	—
a6(E)	16	#5	25'-5"	—
a7(E)	8	#6	25'-0"	—
a8(E)	8	#6	25'-5"	—
d(E)	48	#5	3'-0"	—
d1(E)	24	#5	2'-7"	↙
d4(E)	8	#4	3'-7"	┌
d5(E)	8	#4	3'-7"	┌
d6(E)	8	#4	3'-0"	┌
u(E)	96	#5	2'-9"	□
Reinforcement Bars, Epoxy Coated			Pound	2,040
Concrete Superstructure			Cu. Yd.	15.8

MODEL: Default
FILE NAME: P:\Effingham\4852 - IDOT FTB 198-018_D4_VVAWork Order #107 Rehab WO 10 RT16 Superstructure Plan - Deck Reinforcing - 0007.dgn
CIVIL DESIGN, INC. WBE / DBE
EFFINGHAM, IL LICENSE #184.003222



USER NAME =	DESIGNED - RBT	REVISED -
PLOT SCALE =	CHECKED - MJH	REVISED -
PLOT DATE =	DRAWN - RBT	REVISED -
	CHECKED - MJH	REVISED -

STATE OF ILLINOIS
DEPARTMENT OF TRANSPORTATION

SUPERSTRUCTURE REPAIR PLAN - DECK REINFORCEMENT DETAILS
S.N. 048-0007 (E.B.)

SHEET 16 OF 34 SHEETS

F.A.I. RTE. 74	SECTION 48(126VB)BY.BY-1]BR	COUNTY KNOX	TOTAL SHEETS 69	SHEET NO. 35
ILLINOIS FED. AID PROJECT			CONTRACT NO. 68D83	

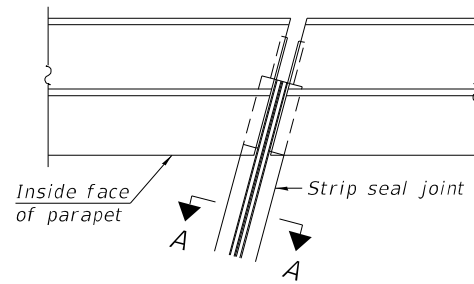

PLAN AT PARAPET

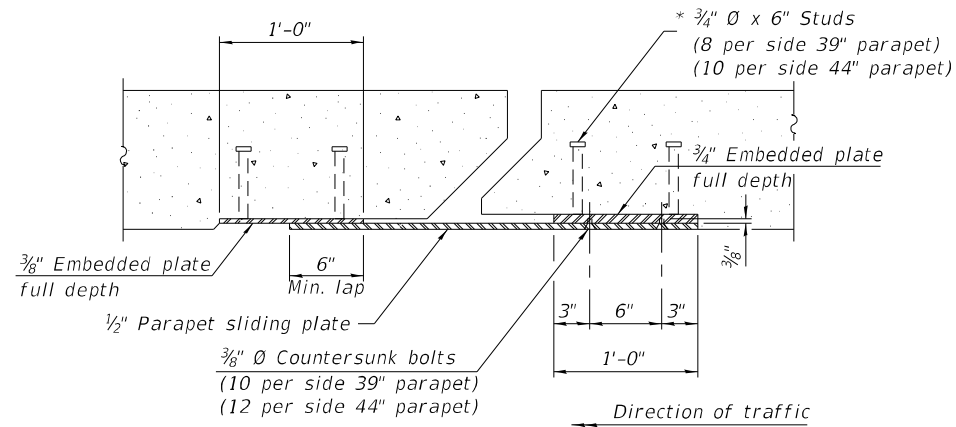

SECTION B-B

Notes:
 The strip seal shall be made continuous and shall have a minimum thickness of 1/4". The configuration of the strip seal shall match the configuration of the locking edge rails. Open or "webbed" strip seal gland configurations are not permitted. The gland shall be sized for a maximum rated movement of 4 inches.
 The locking edge rails depicted are configured for typical applications and are conceptual only. The actual configuration of the locking edge rails and matching strip seal may vary from manufacturer to manufacturer provided they fit the application and meet the minimum anchorage shown. Flanged edge rails, however, will not be allowed.
 The manufacturer's recommended installation methods shall be followed.
 All steel components shall be galvanized after fabrication according to Article 520.03 of the Standard Specifications.
 The Maximum space between locking edge rail segments shall be 3/16" and sealed with a suitable sealant; however, any rail joint within 10' measured perpendicular to the face of the curb or parapet shall be welded as shown in the locking edge rail splice detail.

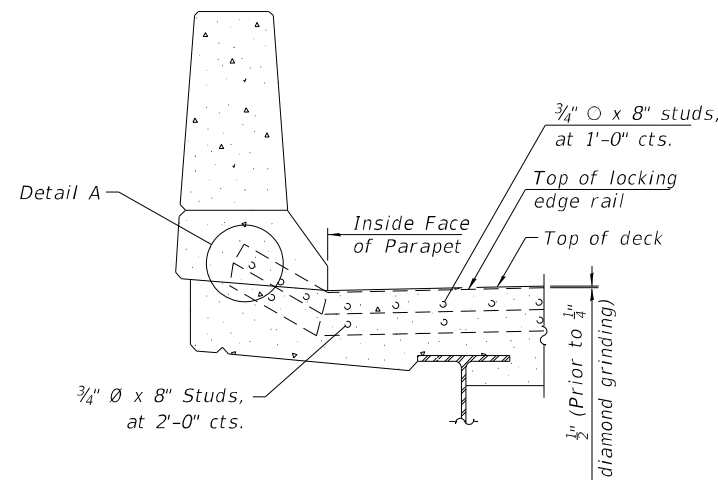

SECTION AT PARAPET

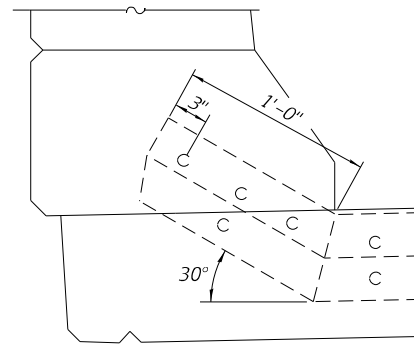

DETAIL A

Cost of parapet sliding plates, embedded plates, and anchorage studs included with Preformed Joint Strip Seal.
 The concrete opening below the strip seal will vary based on the locking edge rail chosen by the Contractor. Deck and parapet lengths shown elsewhere in the plans are dimensioned to the concrete opening, not the joint opening, and are based on the rolled locking edge rail. If the Contractor elects to use a different locking edge rail, dimensional adjustments may be required. One exception to this would be the strip seal joint at the end of the precast bridge approach slab. For these cases the pavement connector length shall be adjusted, not the length of the bridge approach slab.

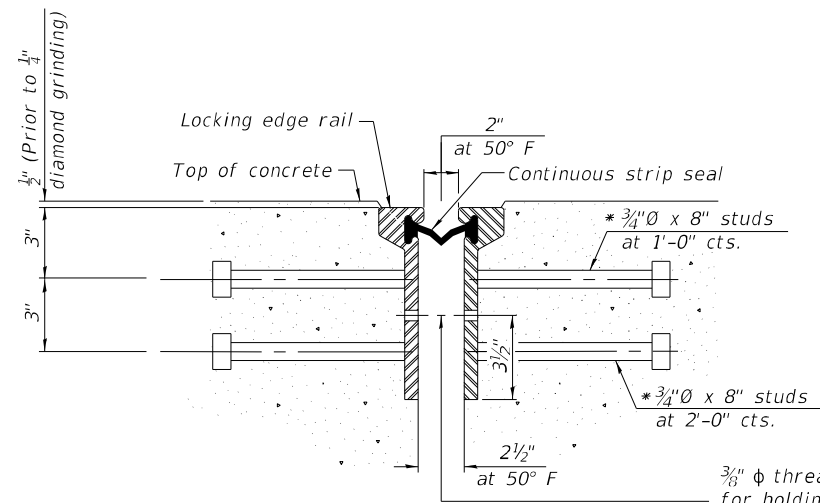

SHOWING ROLLED RAIL JOINT

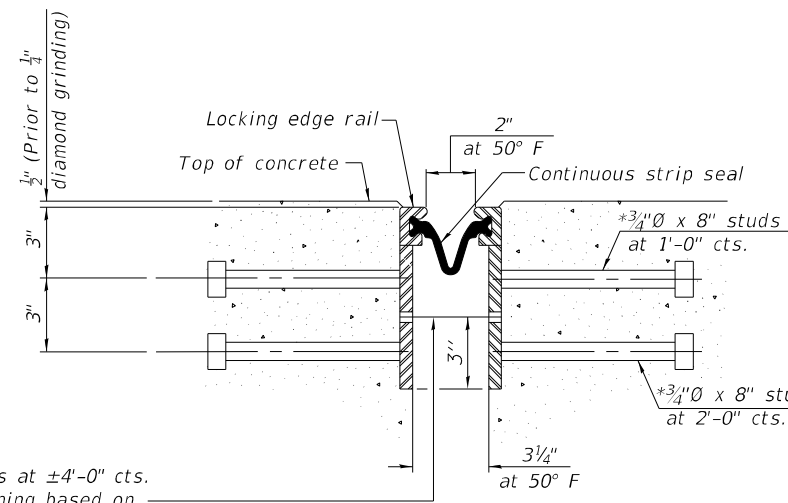

SHOWING WELDED RAIL JOINT

3/8" Ø threaded rods in 7/16" Ø holes at ±4'-0" cts. for holding the proper joint opening based on the temperature during the deck pour. Place to miss studs. All rods shall be burned, or sawed off flush with the plates after concrete is set.

SECTION A-A

* Granular or solid flux filled headed studs conforming to Article 1006.32 of the Std. Specs., automatically end welded.

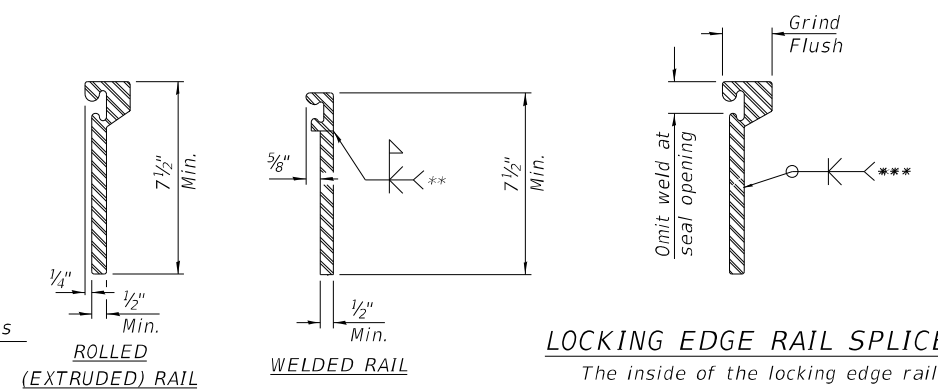

LOCKING EDGE RAILS

** Back gouge not required if complete joint penetration is verified by mock-up.

LOCKING EDGE RAIL SPLICE

The inside of the locking edge rail groove shall be free of weld residue. Rolled rail shown, welded rail similar.

BILL OF MATERIAL

Structure	Item	Unit	Total
048-0008	Preformed Joint Strip Seal	Foot	84
048-0007	Preformed Joint Strip Seal	Foot	102

MODEL: Default
 FILE NAME: P:\Effingham\4852 - IDOT FTB 198-018_D4_VVAWork Order #10V Rehab WO 10 RT17 Preformed Joint Strip Seal Detail 0008 0007.dgn
 10/19/2023 3:55:28 PM



CIVIL DESIGN, INC.
 WBE / DBE
 EFFINGHAM, IL
 LICENSE #184.003222

USER NAME	DESIGNED	REVISIONS
RBT	RBT	
MJH	MJH	
RBT	RBT	
MJH	MJH	

STATE OF ILLINOIS
 DEPARTMENT OF TRANSPORTATION

PREFORMED JOINT STRIP SEAL DETAILS
 S.N. 048-0008 (W.B.) S.N. 048-0007 (E.B.)

SHEET 17 OF 34 SHEETS

F.A.I. RTE.	SECTION	COUNTY	TOTAL SHEETS	SHEET NO.
74	48[(26VB)BY.BY-1]BR	KNOX	69	36
CONTRACT NO. 68D83				
ILLINOIS FED. AID PROJECT				

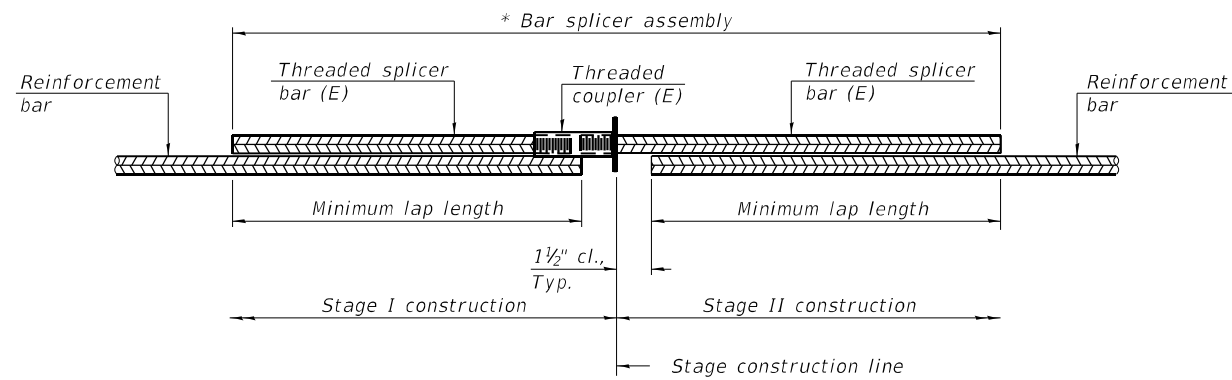

STANDARD BAR SPLICER ASSEMBLY PLAN

All components shall be provided from one supplier

Threaded splicer bar length = min. lap length + 1 1/2" + thread length

* Epoxy not required on Bar Splicer Assembly components used in conjunction with black bars.

Location	Size	No. Reqd.	Min. Lap Length
Deck End	#5	32	3'-6"
Abutments	#6	16	4'-0"

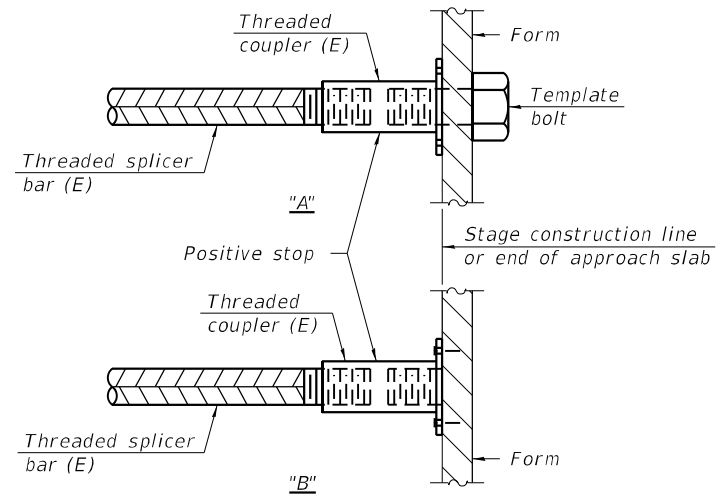

INSTALLATION AND SETTING METHODS

"A" : Set bar splicer assembly by means of a template bolt.

"B" : Set bar splicer assembly by nailing to wood forms or cementing to steel forms.

(E) : Indicates epoxy coating.

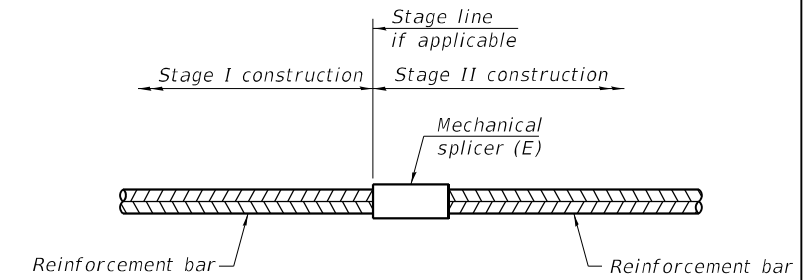

STANDARD MECHANICAL SPLICER

Notes:

- Splicer bars shall be deformed with threaded ends and have a minimum 60 ksi yield strength.
- All reinforcement shall be lapped and tied to the splicer bars.
- Bar splicer assemblies shall be epoxy coated according to the requirements for reinforcement bars. See Section 508 of the Standard Specifications.
- See approved list of bar splicer assemblies and mechanical splicers for alternatives.

MODEL: Default
FILE NAME: X:\Effingham\4852 - IDOT PTB 195-018_D4_VV\Work Order #10% Rehab WO 10 RT\18 Bar Splicer.dgn
12/5/2023 10:35:22 AM



CIVIL DESIGN, INC.
WBE / DBE
EFFINGHAM, IL
LICENSE # 184.003222

USER NAME =	DESIGNED - RBT	REVISOR -
CHECKED - MJH	REVISIONS -	
PLOT SCALE =	DRAWN - RBT	REVISIONS -
PLOT DATE =	CHECKED - MJH	REVISIONS -

STATE OF ILLINOIS
DEPARTMENT OF TRANSPORTATION

BAR SPLICER ASSEMBLY AND MECHANICAL SPLICER DETAILS
S.N. 048-0008 (W.B.) S.N. 048-0007 (E.B.)

SHEET 18 OF 34 SHEETS

F.A.I. RTE.	SECTION	COUNTY	TOTAL SHEETS	SHEET NO.
74	48[(26VB)BY, BY-1]BRR	KNOX	69	37
CONTRACT NO. 68D83				
ILLINOIS		FED. AID PROJECT		

Bench Mark: USC & GS Stand. Br. Disk on top of N.W. parapet wall I-74 E.B. over Main St. (S.N. 048-0009)
"Gale RM2" Elev. 801.55

STATE OF ILLINOIS
DEPARTMENT OF TRANSPORTATION

PROJECT NO.	SECTION	DATE	SHEET	SHEET NO.
F.A.I. 74	48-26VB	KNOX	120	23
BY&BY-1				12 SHEETS

Existing Structure: 048-0007(E.B.), 048-0008(W.B.), built as dual 3-span continuous wide flange structures in 1963 to carry F.A.I. 74 over the A.T.&S.F. Railroad. The bridges will be widened and rehabilitated in accordance with the scope of work shown. Stage construction shall be utilized to maintain one lane of traffic in each direction at all times. No salvage.

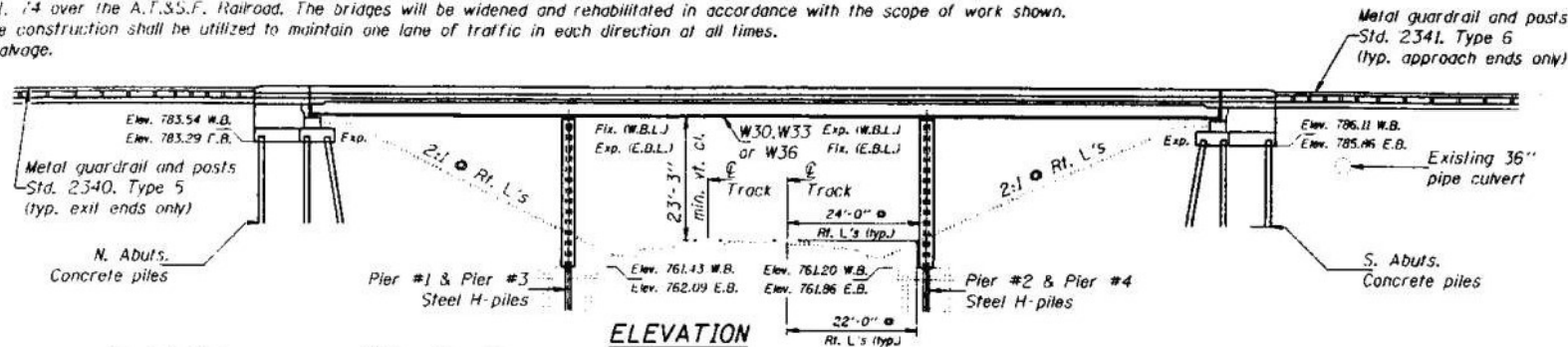

STATION 339+24.54
REBUILT IN BY
STATE OF ILLINOIS
F.A.I. RT. 74-***
F.A.I. PROJ. ACIM-74-2(13)44
LOADING HS20 & ALT.
STR. NO. 048-0007
NAME PLATE
Showing East Bound
See Std. 2113
***SEC. (48-26VB)BY&BY-1

STATION 339+24.54
REBUILT IN BY
STATE OF ILLINOIS
F.A.I. RT. 74-***
F.A.I. PROJ. ACIM-74-2(13)44
LOADING HS20 & ALT.
STR. NO. 048-0008
NAME PLATE
Showing West Bound
See Std. 2113
***SEC. (48-26VB)BY&BY-1

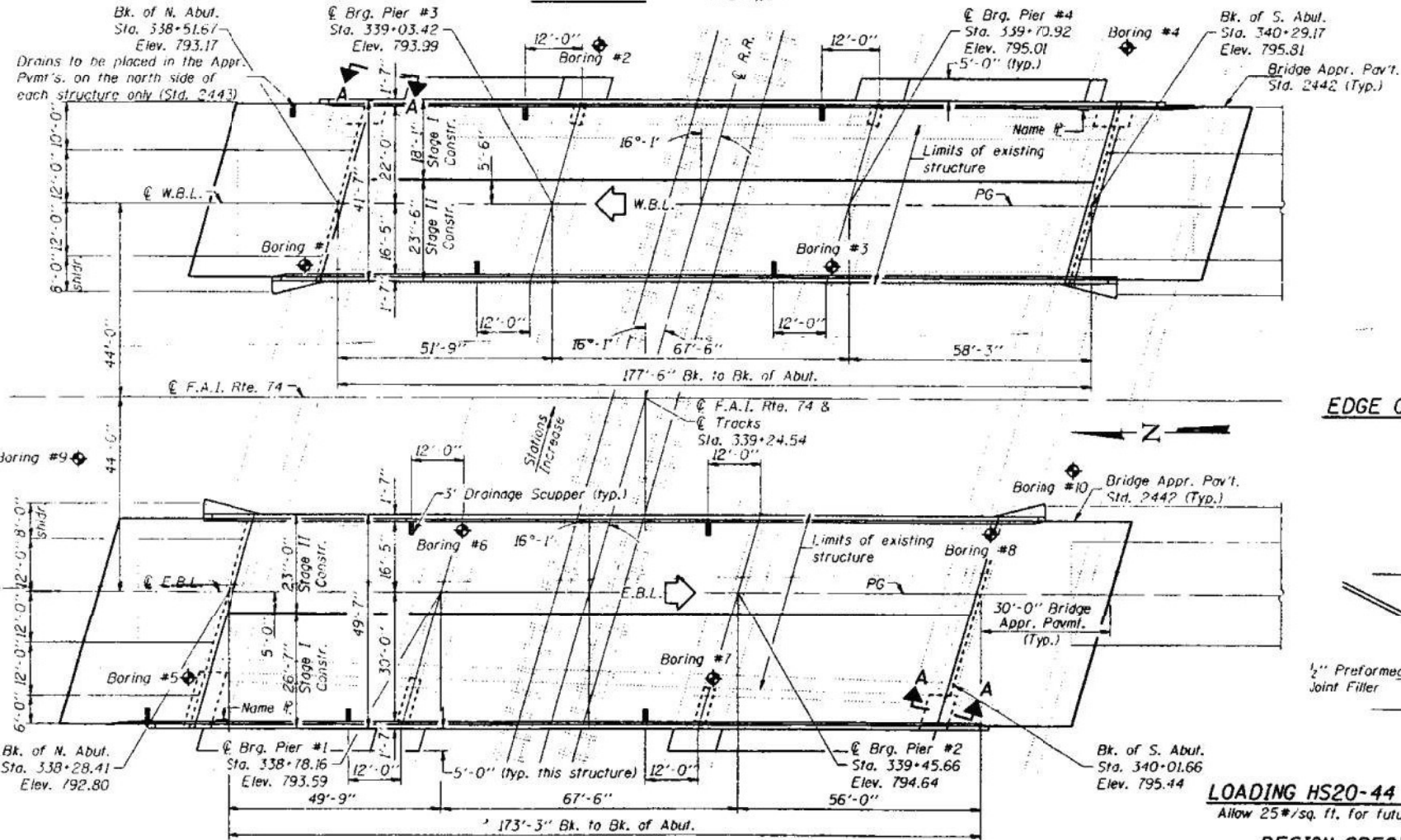

TOTAL BILL OF MATERIAL

ITEM	UNIT	SUPER	SUB	TOTAL
Concrete Removal	Cu. Yd.		23	23
Removal of Existing Concrete Deck	Each	2		2
Structure Excavation	Cu. Yd.		194	194
Concrete Superstructure	Cu. Yd.	479.5		479.5
Protective Coat	Sq. Yd.	320		320
Elastomeric Bearing Assembly Type I	Each	32		32
Elastomeric Bearing Assembly Type II	Each	16		16
Concrete Structures	Cu. Yd.		157.5	157.5
Structural Steel	L.S.	0.3		0.3
Reinforcement Bars, Epoxy Coated	Pound	106,410	17,990	124,400
Concrete Piles	DOT		394	394
Test Pile Concrete	Each		2	2
Steel Piles HP12 x 74	DOT		330	330
Test Pile Steel HP12 x 74	Each		1	1
Name Plates	Each	2		2
Bridge Seat Sealer	Sq. Ft.		377	377
Neoprene Expansion Joint 2"	DOT	185		185
Jack and Remove Existing Bearings	Each		39	39
Drainage Scuppers	Each	8		8
Protective Shield	Sq. Yd.	504		504
Bridge Deck Grooving	Sq. Yd.	1551		1551
Slope Wall (4")	Sq. Yd.		364	364
Structural Steel Removal	Pound	6660		6660
Cleaning and Painting Steel Bridge	L.S.	1		1
Power Tool Cleaning Residue Containment and Disposal	L.S.	1		1
Blasting Residue Containment and Disposal	L.S.	1		1
Bar Splicers	Each	1008	16	1024
Bituminous Concrete Surface Removal (Asbestos)	Sq. Yd.	1232		1232

SECTION A-A

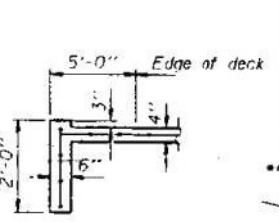

EDGE OF SLOPEWALL DETAIL

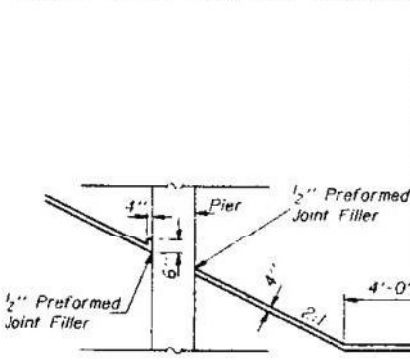

SECTION THRU SLOPEWALL

LOADING HS20-44 & ALTERNATE
Allow 25#/sq. ft. for future wearing surface.

DESIGN SPECIFICATIONS
1989 AASHTO and 1990, 1991 Interim Specifications
& Seismic Retrofitting Guidelines for Highway Bridges
Acceleration Coefficient = .04

DESIGN STRESSES
EXISTING
f_s = 20,000 psi Structural Steel (A36)
f_y = 40,000 psi (Reinforcement)
NEW CONSTRUCTION
f_s = 3,500 psi
f_y = 60,000 psi (Reinforcement)
f_s = 20,000 psi Structural Steel (M270 Grade 36)

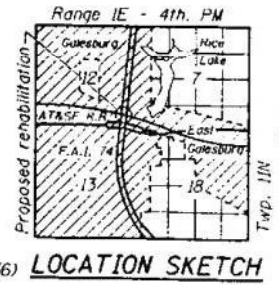

GENERAL PLAN
I-74 OVER A.T. & S.F. R.R.
F.A.I. RTE. 74-SEC. (48-26VB)BY&BY-1
KNOX COUNTY
STATION 339+24.54
STRUCTURE NO. 048-0007 & 0008

DESIGNED: [Signature]
CHECKED: [Signature]
DRAWN: SHANE SUMNER
CHECKED: [Signature]
EXAMINED: [Signature]
PASSED: [Signature]
Aug. 25, 1994

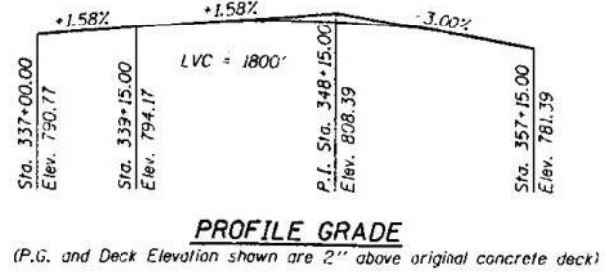

STATE OF ILLINOIS
DEPARTMENT OF TRANSPORTATION

EXISTING PLANS
S.N. 048-0008 (W.B.) & 048-0007 (E.B.)

SHEET 19 OF 34 SHEETS

F.A.I. RTE.	SECTION	COUNTY	TOTAL SHEETS	SHEET NO.
74	48(26VB)BY&BY-1	KNOX	69	38
CONTRACT NO. 68D83			ILLINOIS FED. AID PROJECT	

MODEL: Default
FILE NAME: P:\Effingham\4852 - IDOT FTB 198-018_D4_VVAWork Order #102 Rehab WO 10 RTU19 Existing GPE.dgn
10/19/2023 3:55:37 PM

MODEL: Default
 FILE NAME: P:\Effingham\4852 - IDOT FTB 198-018_D4_VVAWork Order #102 Rehab WO 10 RT20 Existing.dgn
 10/19/2023 3:56:28 PM

PROJECT NO.	SECTION	COUNTY	SHEET NO.	TOTAL SHEETS
48-26VB	BY&BY-1	KNOX	120	32

STATE OF ILLINOIS
 DEPARTMENT OF TRANSPORTATION

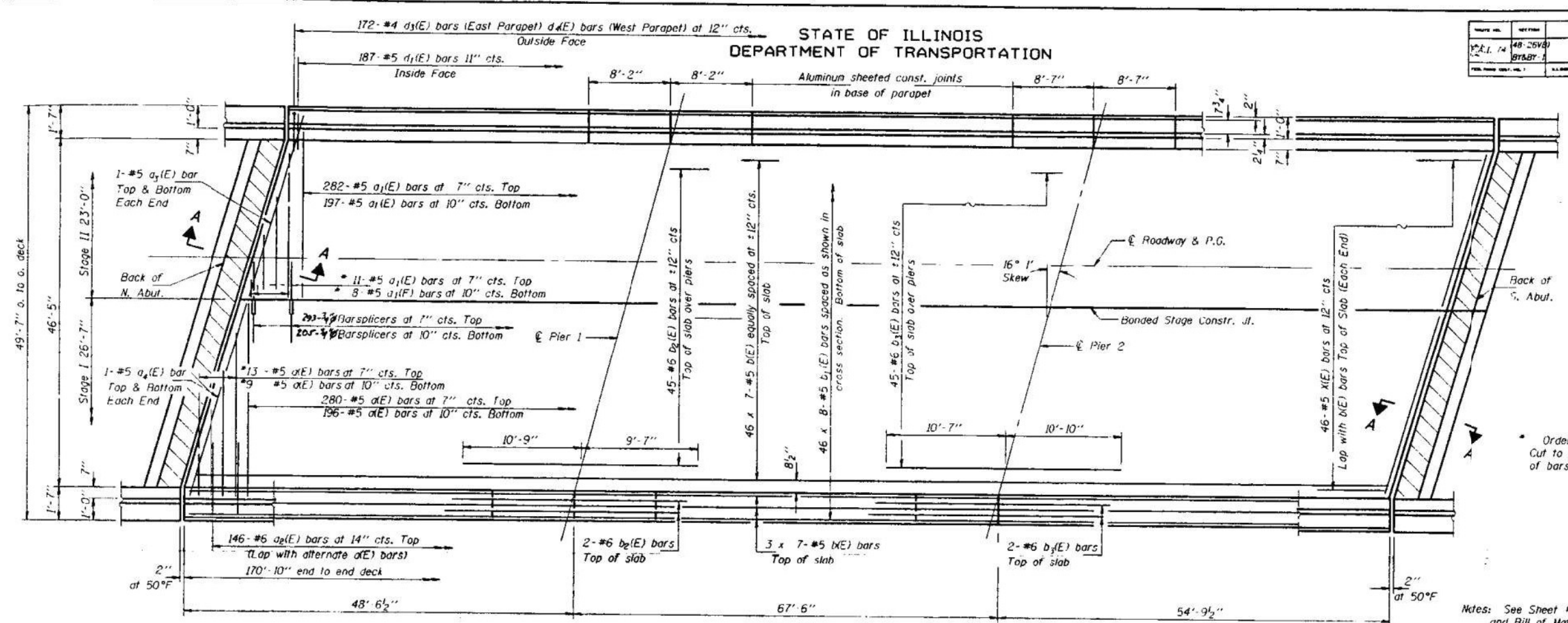

PLAN

* Order a₁(E) & a₂(E) bars full length. Cut to fit skew and use remainder of bars in opposite end.

Notes: See Sheet #11 of 42 for superstructure details and Bill of Material.
 Reinforcement bars designated (E) shall be epoxy coated.
 Bars indicated thus 20 x 3-#5 etc. indicates 20 lines of bars with 3 lengths per line.
 See Sheet #11 of 42 for parapet reinforcement. Hatched Area to be poured after Superstructure forms have been removed. Quantity of Concrete included with Concrete Superstructure.

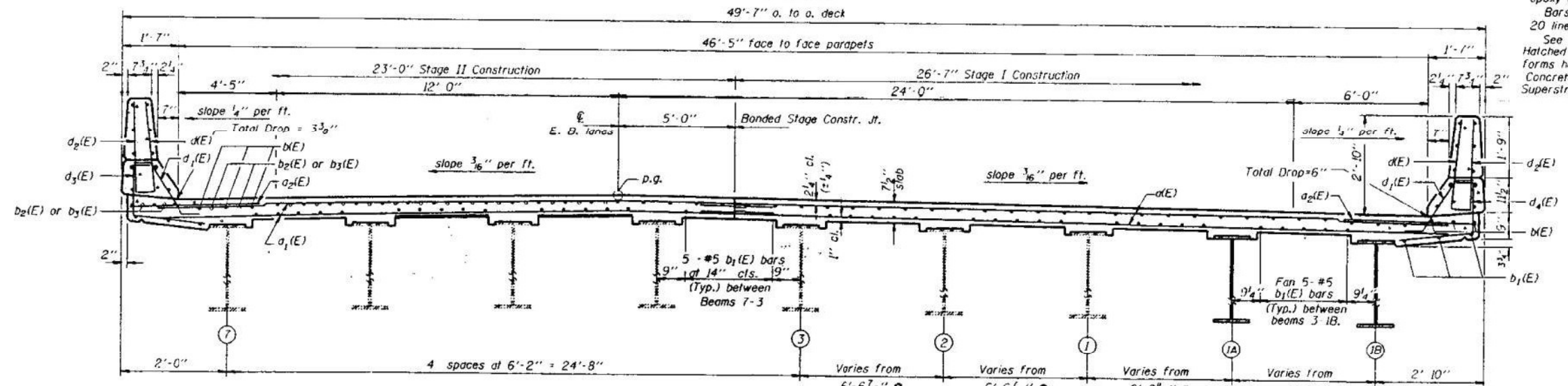

CROSS SECTION
 (Looking South)

MIN. BAR LAP
 #5 = 1'-8"

DESIGNED: RBT
 CHECKED: MJH
 DRAWN: SHANE SUMNER
 CHECKED: RBT
 EXAMINED: Ralph E. Anderson
 PASSED: Ralph E. Anderson
 Aug. 25, 1994

NEAR PIER

NEAR MIDSPAN

E. B. SUPERSTRUCTURE
 I-74 OVER A.T. & S.F. R.R.
 F.A.I. RTE. 74-SEC. (48-26VB)BY&BY-1
 KNOX COUNTY
 STATION 339+24.54

STATE OF ILLINOIS
 DEPARTMENT OF TRANSPORTATION

EXISTING PLANS
 S.N. 048-0008 (W.B.) & 048-0007 (E.B.)

USER NAME =	DESIGNED - RBT	REVISED -
PLOT SCALE =	CHECKED - MJH	REVISED -
PLOT DATE =	DRAWN - RBT	REVISED -
	CHECKED - MJH	REVISED -

F.A.I. RTE.	SECTION	COUNTY	TOTAL SHEETS	SHEET NO.
74	48(26VB)BY&BY-1	KNOX	69	39
			CONTRACT NO.	68D83
			ILLINOIS	FED. AID PROJECT

STATE OF ILLINOIS
DEPARTMENT OF TRANSPORTATION

PROJECT NO.	SECTION	COUNTY	SHEET NO.	TOTAL SHEETS
S.A. 74	48-26VB	KNOX	120	33
SHEET NO. 11				
42 SHEETS				

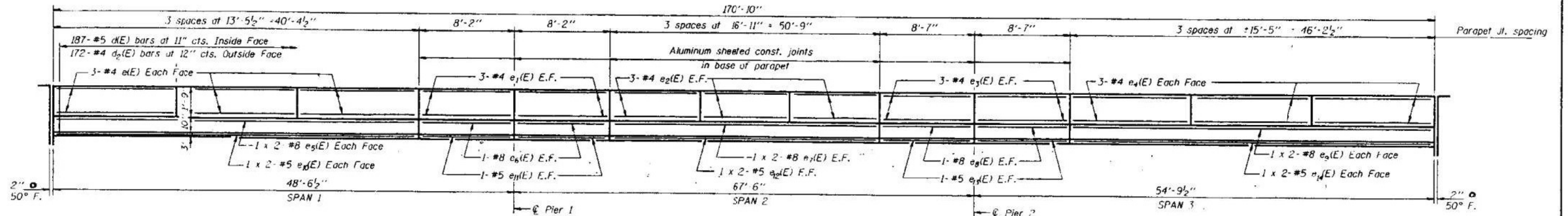

INSIDE ELEVATION OF PARAPET

SUPERSTRUCTURE
BILL OF MATERIAL

Bar No.	Size	Length	Shape
a(E)	#5	25'-5"	
a ₁ (E)	#5	21'-10"	
a ₂ (E)	#6	4'-0"	
a ₃ (E)	#5	23'-6"	
a ₄ (E)	#5	27'-2"	
a ₅ (E)	#5	2'-0"	
b(E)	#5	25'-10"	
b ₁ (E)	#5	22'-10"	
b ₂ (E)	#6	20'-4"	
b ₃ (E)	#6	21'-5"	
c(E)	#5	3'-0"	
c ₁ (E)	#5	2'-7"	
c ₂ (E)	#4	3'-0"	
c ₃ (E)	#4	3'-0"	
c ₄ (E)	#4	3'-10"	
d(E)	#4	13'-2"	
d ₁ (E)	#4	7'-11"	
d ₂ (E)	#4	16'-8"	
d ₃ (E)	#4	8'-4"	
d ₄ (E)	#4	15'-2"	
d ₅ (E)	#8	22'-4"	
d ₆ (E)	#8	2'-4"	
d ₇ (E)	#8	27'-7"	
d ₈ (E)	#8	8'-4"	
d ₉ (E)	#8	25'-5"	
d ₁₀ (E)	#5	21'-3"	
d ₁₁ (E)	#5	7'-11"	
d ₁₂ (E)	#5	26'-4"	
d ₁₃ (E)	#5	8'-4"	
d ₁₄ (E)	#5	24'-3"	
x(E)	#5	4'-1"	
Reinforcement Bars (Epoxy Coated)			Lbs. 56300
Concrete Superstructure			Cu. Yds. 254.1

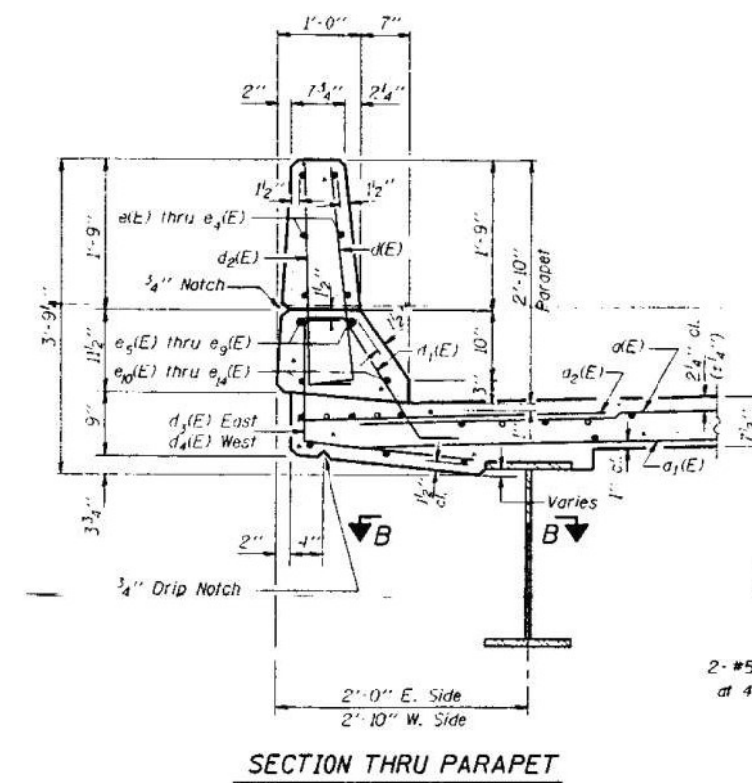

SECTION THRU PARAPET

MIN. BAR LAP
#5 bars = 2'-2"
#8 bars = 4'-6"

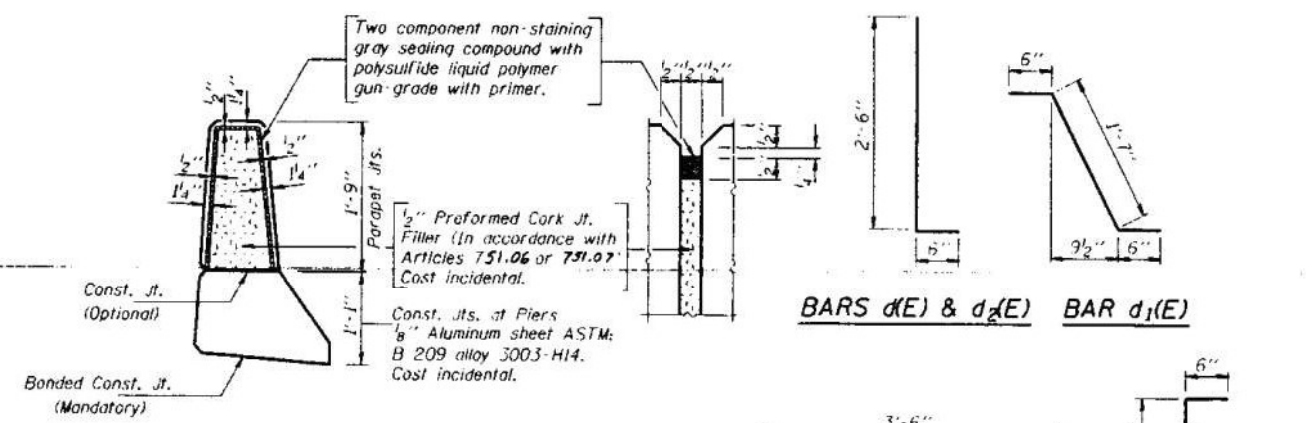

PARAPET JOINT DETAILS

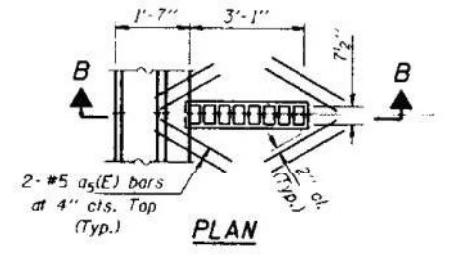

PLAN

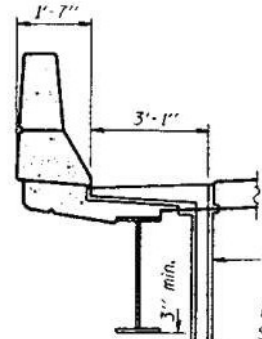

SECTION B-B

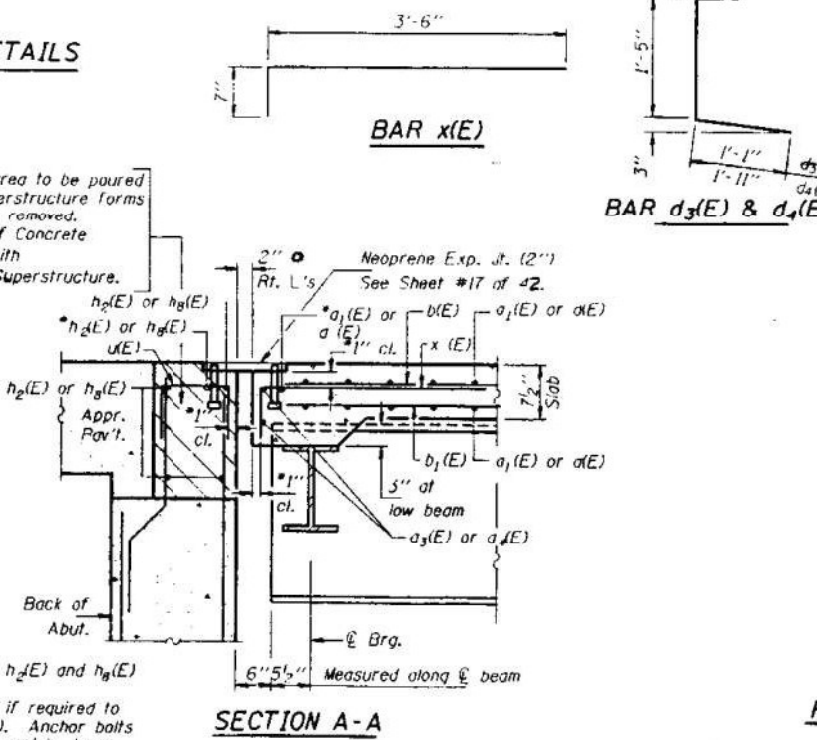

SECTION A-A

DESIGNED: [Signature]
CHECKED: [Signature]
DRAWN: SHANE SUMNER
CHECKED: [Signature]
S-2-D 12-31-87

EXAMINED: [Signature]
PASSED: [Signature]
APR 25, 1994

STATE OF ILLINOIS
DEPARTMENT OF TRANSPORTATION

EXISTING PLANS
S.N. 048-0008 (W.B.) & 048-0007 (E.B.)

F.A.I. RTE.	SECTION	COUNTY	TOTAL SHEETS	SHEET NO.
74	48(26VB)BY-1]BR	KNOX	69	40
CONTRACT NO. 68D83				

MODEL: Default
FILE NAME: P:\Effingham\4852 - IDOT FTB 198-018_D4_VVAWork Order #1042 Rehab WO 10 RT21 Existing.dgn
10/19/2023 3:57:20 PM



CIVIL DESIGN, INC.
WBE / DBE
EFFINGHAM, IL
LICENSE # 184.003222

USER NAME	DESIGNED	REVISIONS
	RBT	
PLOT SCALE	CHECKED	REVISIONS
	MJH	
PLOT DATE	DRAWN	REVISIONS
	RBT	
	CHECKED	REVISIONS
	MJH	

STATE OF ILLINOIS
DEPARTMENT OF TRANSPORTATION

PROJECT NO.	SECTION	COUNTY	SHEET NO.	TOTAL SHEETS
F.A.I. RTE. 74 (48-26VB) BY&BY-1	KNOX	120	34	12 SHEETS

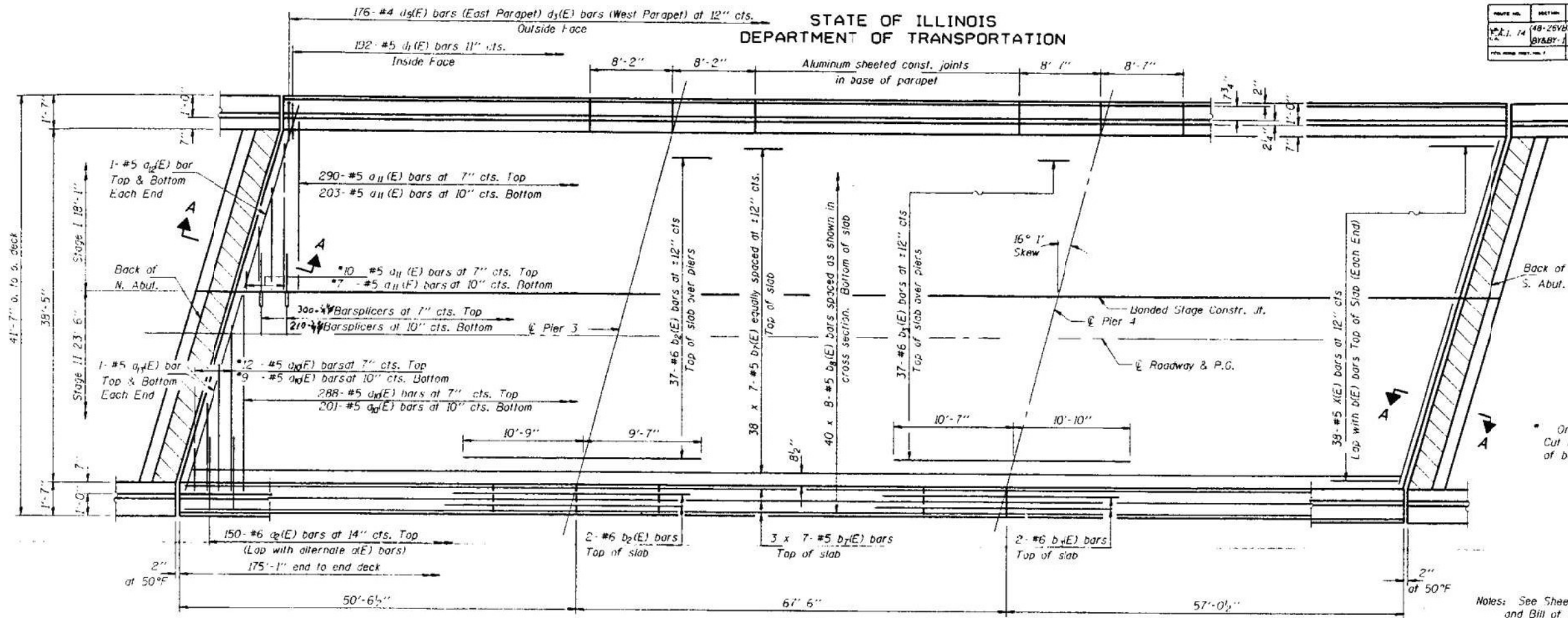

PLAN

Notes: See Sheet #13 of 42 for superstructure details and Bill of Material.
Reinforcement bars designated (E) shall be epoxy coated.
Bars indicated thus 30 x 3-#5 etc. indicates 20 lines of bars with 3 lengths per line.
See Sheet #13 of 42 for parapet reinforcement.
Hatched Area to be poured after Superstructure forms have been removed. Quantity of Concrete included with Concrete Superstructure.

MIN. BAR LAP
#5 - 1'-8"

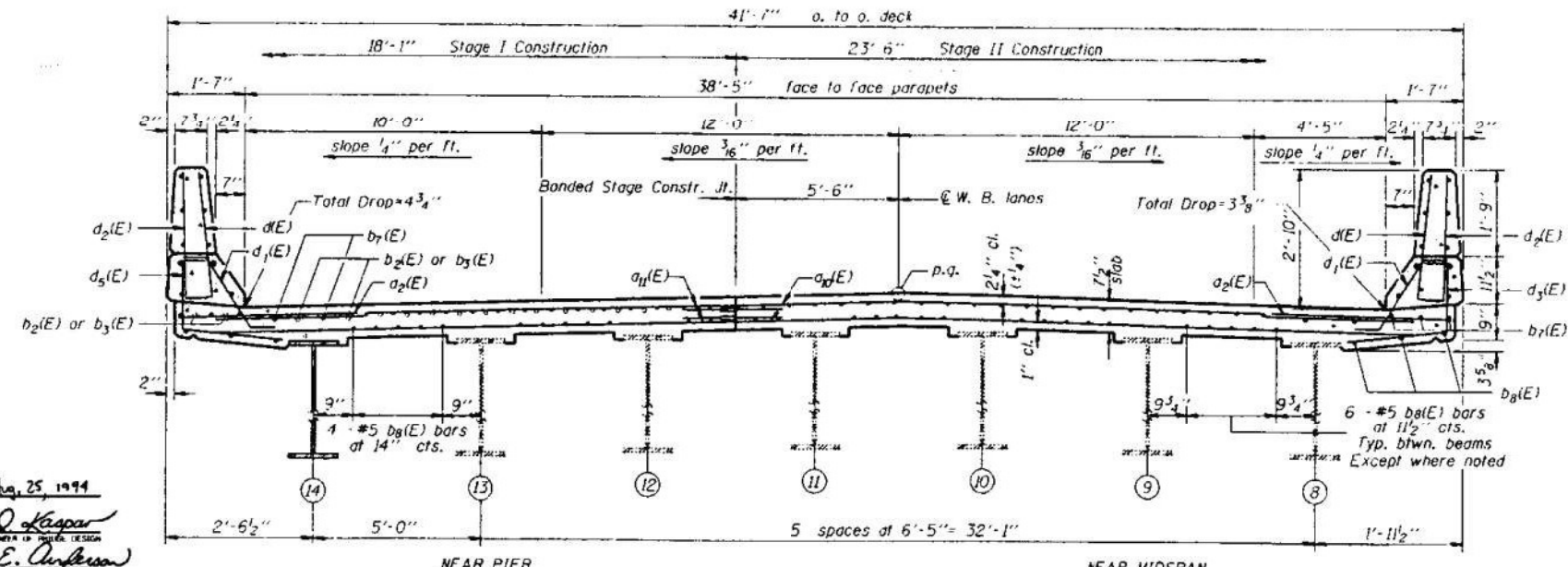

CROSS SECTION
(Looking South)

W. B. SUPERSTRUCTURE
I-74 OVER A.T. & S.F. R.R.
F.A.I. RTE. 74-SEC. (48-26VB)BY&BY-1
KNOX COUNTY
STATION 339+24.54

DESIGNED	PL 1012	EXAMINED	Aug 25, 1994
CHECKED	J.P. & V.M.	PASSED	Ralph E. Anderson
DRAWN	SHANE SUMNER		
CHECKED	J.P.		

S-1-L (>15°) 7-1-91

MODEL: Default
FILE NAME: P:\Effingham\4852 - IDOT FTB 198-018_D4_VVAWork Order #107 Rehab WO 10 RT22 Existing.dgn
10/19/2023 3:58:13 PM



CIVIL DESIGN, INC.
WBE / DBE
EFFINGHAM, IL
LICENSE #184.003222

USER NAME	DESIGNED	CHECKED	DRAWN	CHECKED
	RBT	MJH	RBT	MJH
PLOT SCALE				
PLOT DATE				

STATE OF ILLINOIS
DEPARTMENT OF TRANSPORTATION

EXISTING PLANS
S.N. 048-0008 (W.B.) & 048-0007 (E.B.)

SHEET 22 OF 34 SHEETS

F.A.I. RTE.	SECTION	COUNTY	TOTAL SHEETS	SHEET NO.
74	48(26VB)BY-1]BR	KNOX	69	41
			CONTRACT NO. 68D83	

ILLINOIS FED. AID PROJECT

STATE OF ILLINOIS
DEPARTMENT OF TRANSPORTATION

STATE NO.	SECTION	COUNTY	AREA	DATE	SHEET NO. 13
F.A.I. 74 (18-26VB)	BY&BY-1	KNOX	120	35	+2 SHEETS

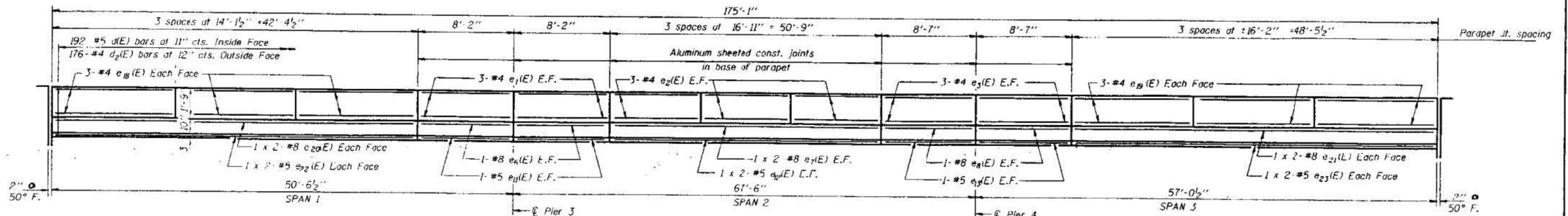

INSIDE ELEVATION OF PARAPET

SUPERSTRUCTURE
BILL OF MATERIAL

Bar	No.	Size	Length	Shape
a ₂ (E)	500	#6	4'-0"	
a ₃ (E)	32	#6	2'-0"	
a ₁₀ (E)	510	#5	22'-6"	
a ₁₁ (E)	510	#5	17'-1"	
a ₁₂ (E)	4	#5	18'-5"	
a ₁₃ (E)	4	#5	24'-1"	
b ₂ (E)	41	#6	20'-4"	
b ₃ (E)	41	#6	21'-5"	
b ₇ (E)	508	#5	26'-5"	
b ₈ (E)	320	#5	23'-4"	
d(E)	384	#5	3'-0"	
d ₁ (E)	384	#5	2'-7"	
d ₂ (E)	352	#4	3'-0"	
d ₃ (E)	176	#4	3'-0"	C
d ₄ (E)	176	#4	3'-7"	C
e ₁ (E)	24	#4	7'-11"	
e ₄ (E)	36	#4	3'-3"	
e ₅ (E)	24	#4	3'-4"	
e ₆ (E)	8	#8	7'-11"	
e ₇ (E)	8	#8	2'-7"	
e ₈ (E)	8	#8	8'-4"	
e ₁₁ (E)	8	#5	7'-11"	
e ₁₂ (E)	8	#5	26'-4"	
e ₁₃ (E)	8	#5	8'-4"	
e ₁₈ (E)	36	#4	15'-10"	
e ₁₉ (E)	36	#4	15'-11"	
e ₂₀ (E)	8	#8	23'-4"	
e ₂₁ (E)	8	#8	26'-5"	
e ₂₂ (E)	8	#5	22'-2"	
e ₂₃ (E)	8	#5	25'-3"	
x(E)	76	#5	4'-1"	
Reinforcement Bars (Epoxy Coated)				Lbs. 50,110
Concrete Superstructure				Cu. Yds. 225.4

MIN. BAR LAP

#5 bars = 2'-2"
#8 bars = 4'-6"

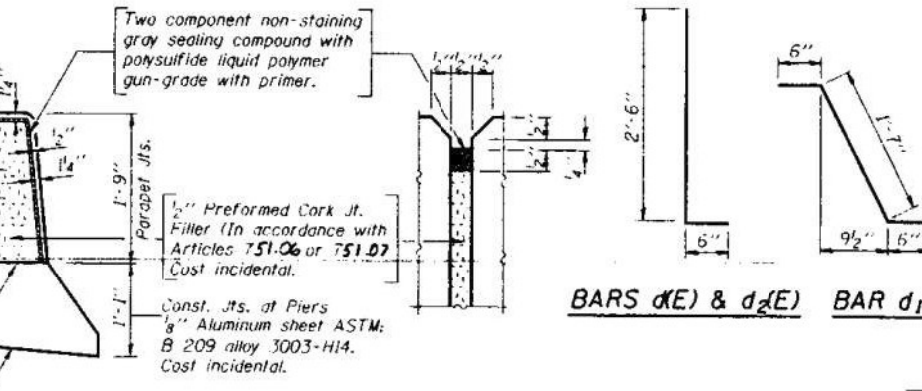

PARAPET JOINT DETAILS

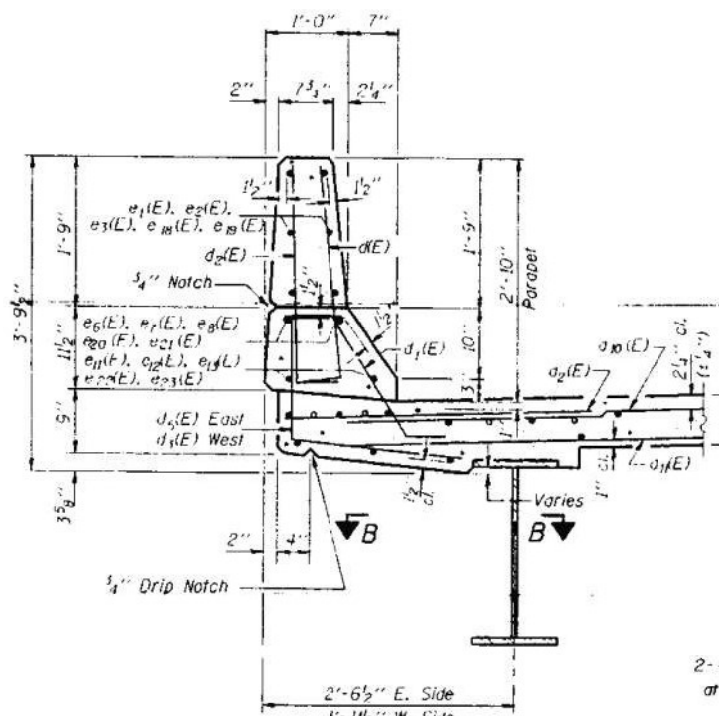

SECTION THRU PARAPET

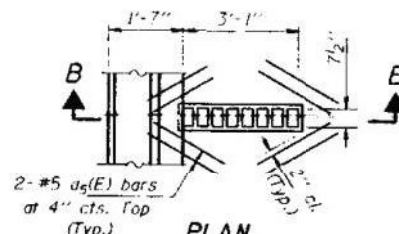

PLAN

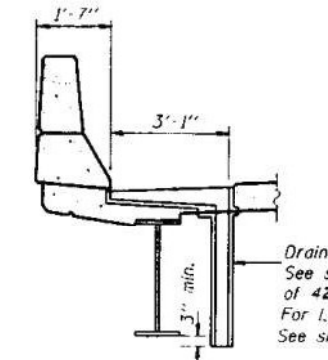

SECTION B-B

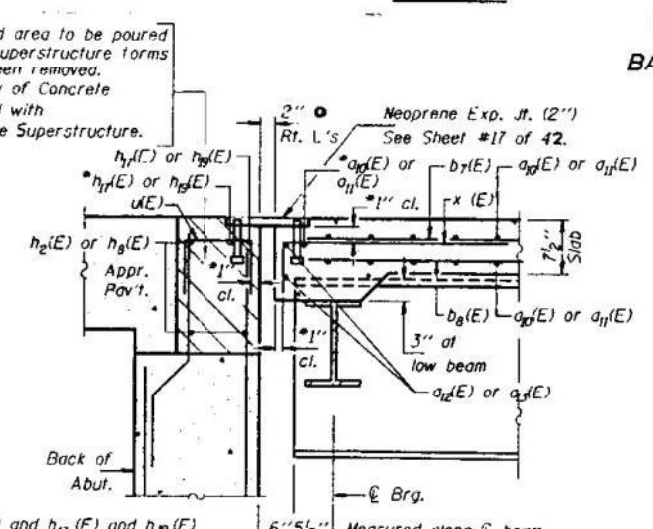

SECTION A-A

DESIGNED: *R.T. Summer*
CHECKED: *R.T. Summer*
DRAWN: *RHANE SUMMER*
CHECKED: *R.T. Summer*

EXAMINED: *Prof. J. Kaspar*
PASSED: *Ralph E. Anderson*

Aug. 25, 1974

S-2-D 12-31-87

Joint Size	"C" at 50° F	"D" at 50° F
2"	2"	1 1/2" Min.
2 1/2"	2 1/2"	1 3/4" Min.
4"	3"	2 1/2" Min.

INSTALLATION NOTES

- Install sponge mandrels into positions shown to form flap convolution.
- Install parapet or sidewalk piece (trim roadway flap to fit before applying epoxy).
- Install continuous seal in roadway.
- Install anchor blocks as indicated.

NOTE A: Maximum spacing of anchor bolts shall be 12" centers.

SKREW LIMITATIONS

The details of the anchor blocks and the elastomeric membrane in the parapet, as shown, are for up to 50° skews. For skews greater than 50°, the anchor blocks and the elastomeric membrane, installed in accordance with dimension "D", might require modifications to insure a minimum clearance of 1/2" from centerline of anchor studs to edge of parapet opening. The anchor blocks and the elastomeric membrane shall also be installed to the top of the parapet with the anchor studs spaced at 12" cts.

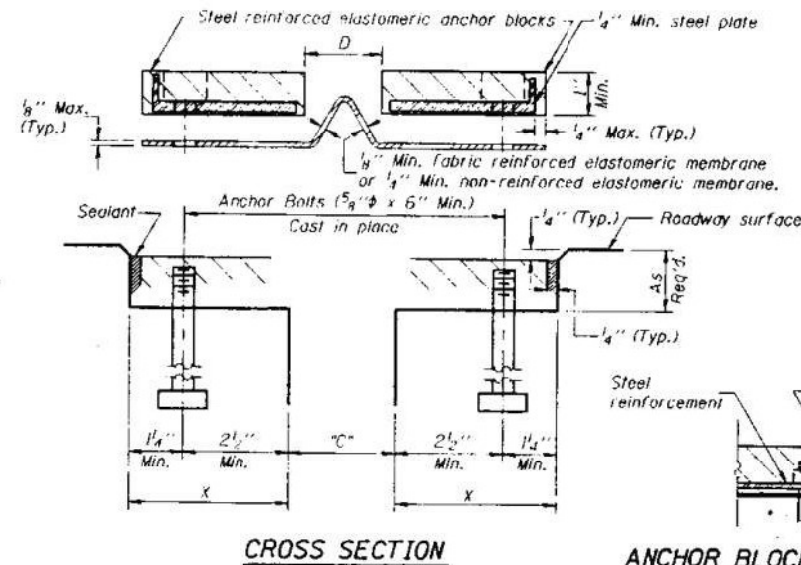
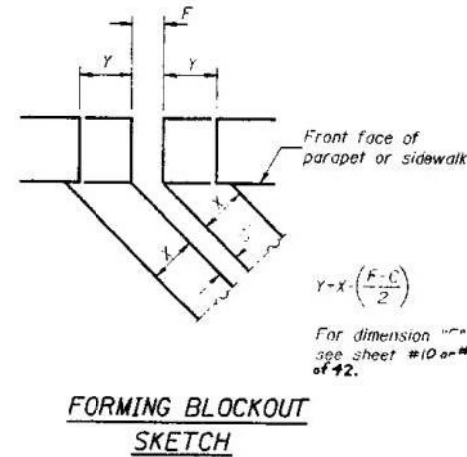

ANCHOR BLOCK REINFORCEMENT WITH ASPHALT SURFACE

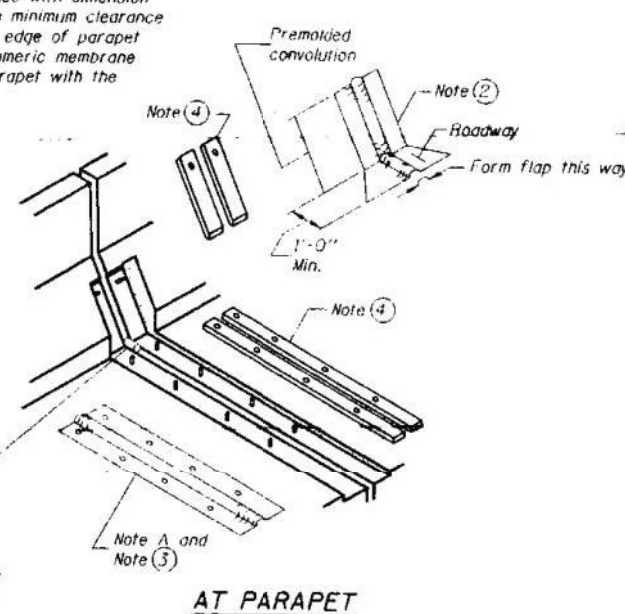

AT CURB

DESIGNED: Pat D. ...
 CHECKED: ...
 DRAWN: SHANE SUMNER
 CHECKED: ...
 EJ-CS 2-26-93

EXAMINED: ...
 PASSED: ...
 Aug. 25, 1994

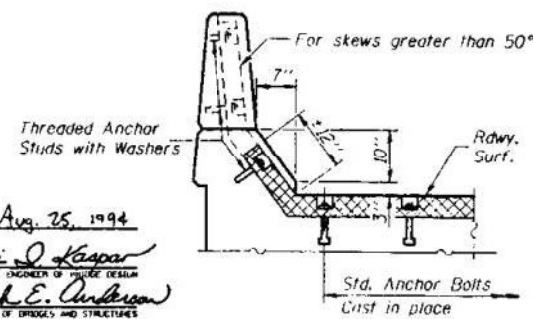

AT PARAPET

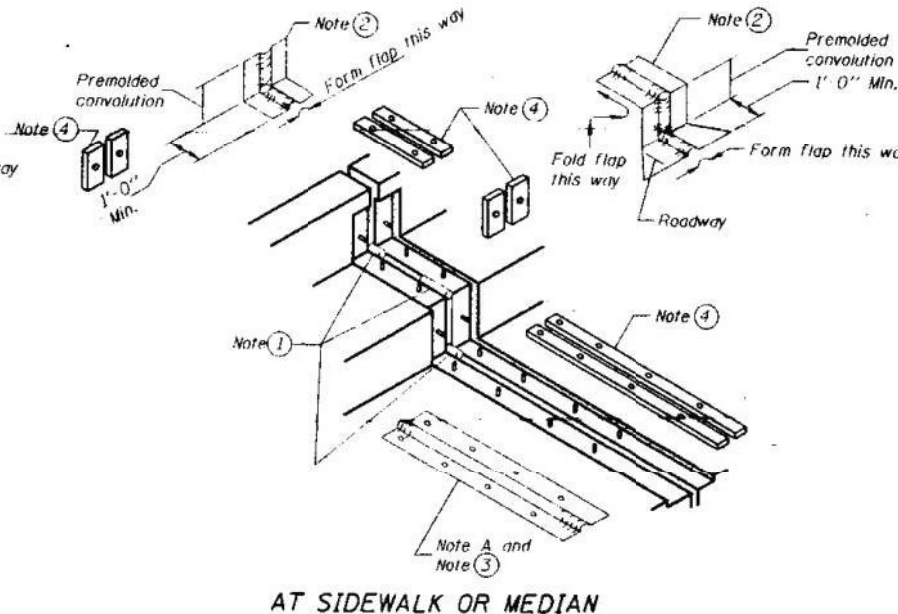

AT SIDEWALK OR MEDIAN

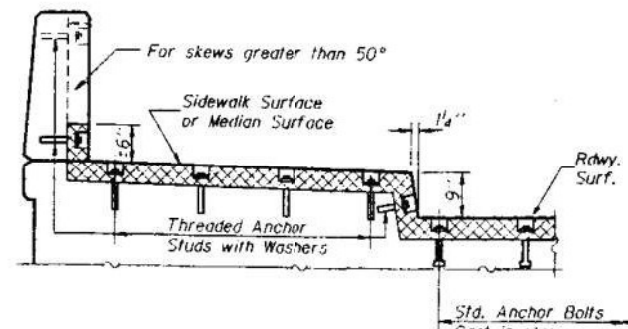

AT SIDEWALK OR MEDIAN TYPICAL END TREATMENTS

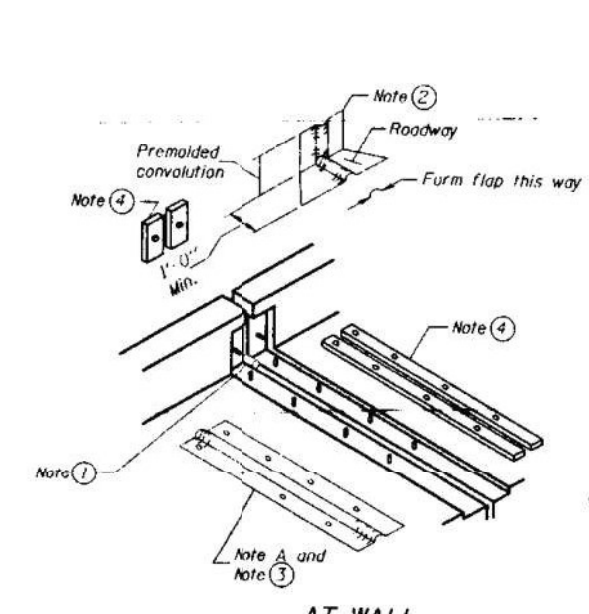

AT WALL

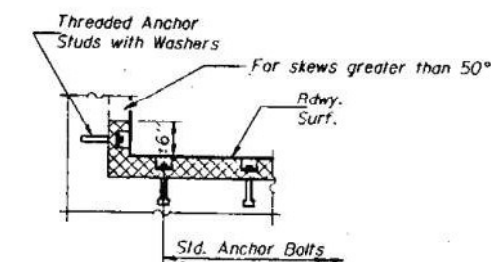

AT WALL

CONTINUOUS SEAL TYPE NEOPRENE EXPANSION JOINTS
 For 2", 2 1/2" and 4" Movement
I-74 OVER A.T. & S.F. R.R.
F.A.I. RTE. 74
SEC. (48-26VB)BY&BY-1
KNOX COUNTY
STATION 339+24.54

MODEL: Default
 FILE NAME: P:\Effingham\4852 - IDOT FTB 198-018_D4_VVAWork Order #1012 RT24 Existing.dgn
 10/19/2023 3:59:57 PM



CIVIL DESIGN, INC.
 WBE / DBE
 EFFINGHAM, IL
 LICENSE #184.003222

USER NAME =	DESIGNED - RBT	REVISED -
PLOT SCALE =	CHECKED - MJH	REVISED -
PLOT DATE =	DRAWN - RBT	REVISED -
	CHECKED - MJH	REVISED -

STATE OF ILLINOIS
 DEPARTMENT OF TRANSPORTATION

EXISTING PLANS
 S.N. 048-0008 (W.B.) & 048-0007 (E.B.)

SHEET 24 OF 34 SHEETS

F.A.I. RTE.	SECTION	COUNTY	TOTAL SHEETS	SHEET NO.
74	48(26VB)BY-1]BR	KNOX	69	43
			CONTRACT NO.	68D83
ILLINOIS FED. AID PROJECT				

STATE OF ILLINOIS
DEPARTMENT OF TRANSPORTATION

DATE	SECTION	COUNTY	SHEET	SHEET NO.
7/21/74	48-26VB	KNOX	120	52
PROJECT NO. 48-26VB(BY-1)				42 SHEETS

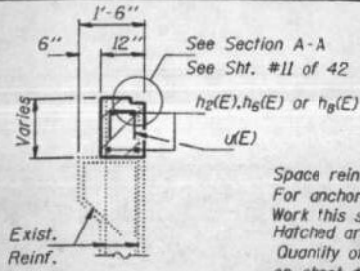

SECTION B-B

Space reinforcement in cap to miss anchor bolts.
For anchor bolt locations, see sht. #20 of 42.
Work this sheet with sht. #32 of 42.
Hatched area to be poured after superstructure forms have been removed.
Quantity of concrete included with Concrete Superstructure on sheet #11 of 42.
Clean and Straighten existing vertical reinforcement and incorporate into new construction.
Pour steps monolithically with cap.
All edges shall have standard 3/4" chamfer except as noted.

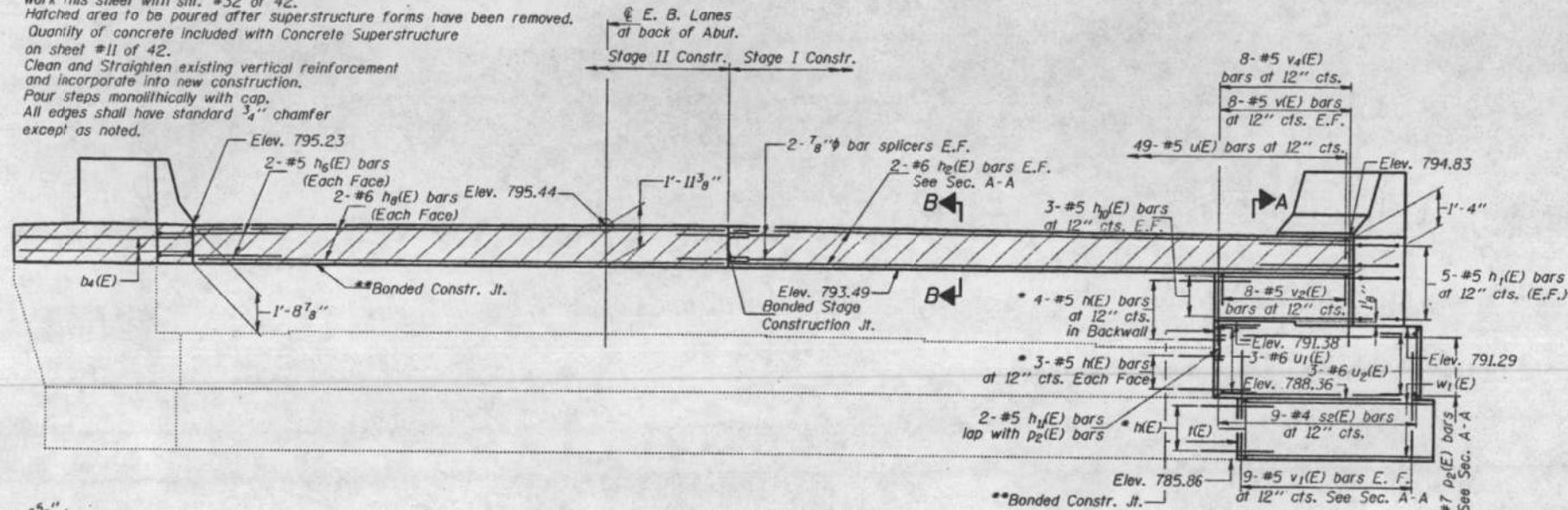

ELEVATION
(looking South)

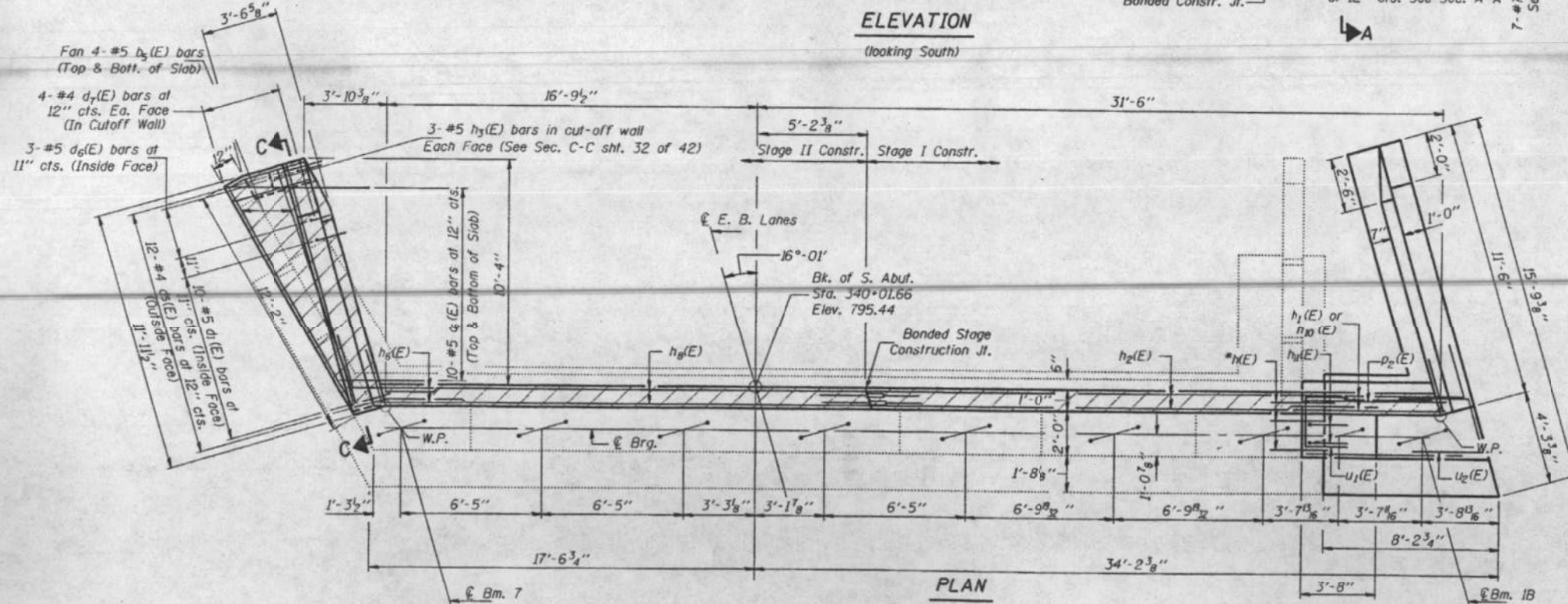

PLAN

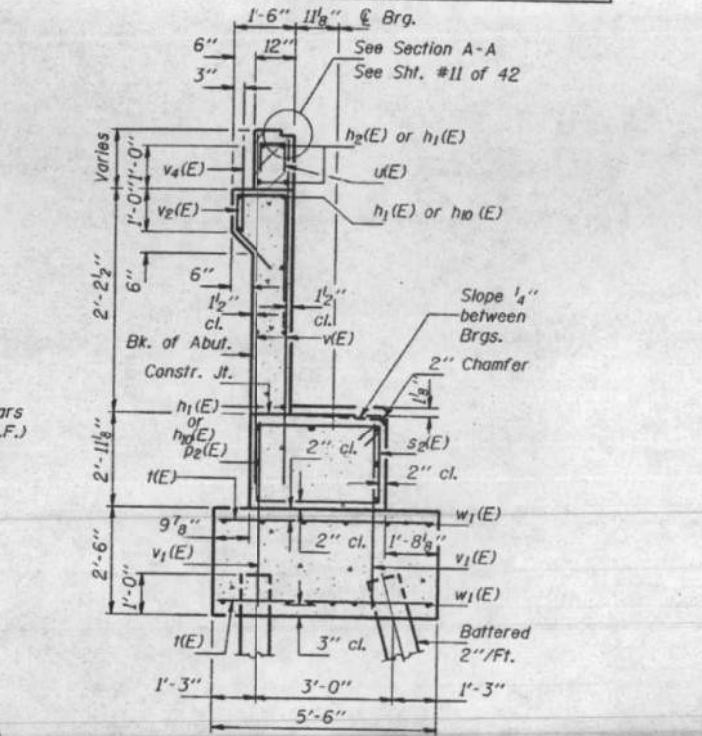

SECTION A-A

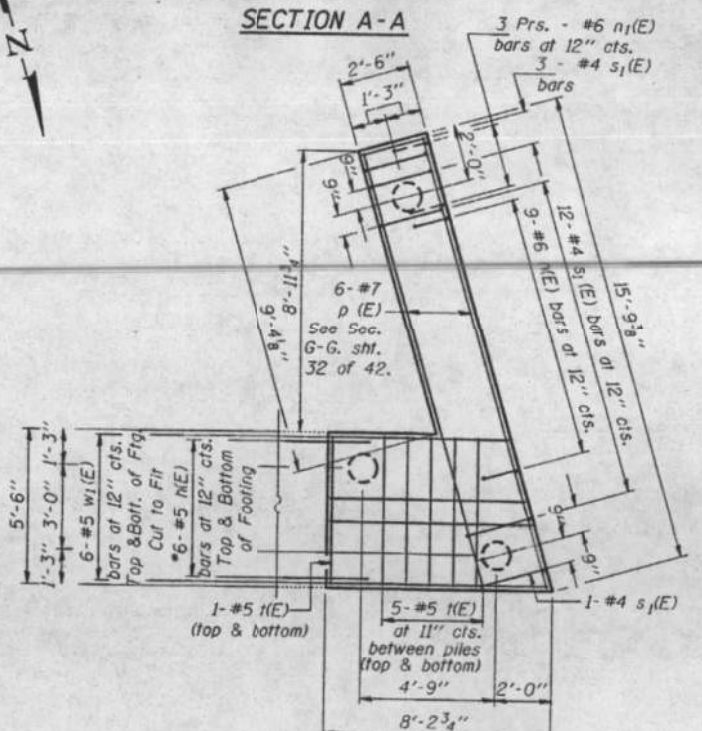

E. B. SOUTH ABUTMENT
I-74 OVER A.T. & S.F. R.R.
F.A.I. RTE. 74-SEC. (48-26VB)BY&BY-1
KNOX COUNTY
STATION 339+24.54

- Drill 7/8" x 9" Min. hole. Epoxy grout n(E) bars. Epoxy grout in accordance with Art. 584 of the Standard Specifications. The method of grout application shall be approved by the Engineer.
- Banded Construction Joint in accordance with Article 503.09(a)(2) of the Standard Specifications

PILE DATA

Type: Concrete
Capacity: 35 Tons
Est. Length: 46 Ft.
No. Required: 2 x 1 Test Pile

MIN. BAR LAPS

#5 (E) bars = 2'-2"

DESIGNED	EXAMINED
CHECKED	PASSED
DRAWN	
CHECKED	

Aug. 25, 1974

STATE OF ILLINOIS
DEPARTMENT OF TRANSPORTATION

EXISTING PLANS
S.N. 048-0008 (W.B.) & 048-0007 (E.B.)

F.A.I. RTE.	SECTION	COUNTY	TOTAL SHEETS	SHEET NO.
74	48(26VB)BY-1]BR	KNOX	69	45
CONTRACT NO. 68D83			ILLINOIS FED. AID PROJECT	



CIVIL DESIGN, INC.
WBE / DBE
EFFINGHAM, IL
LICENSE #184.003222

USER NAME	DESIGNED	REVISIONS
	CHECKED	REVISIONS
PLOT SCALE	DRAWN	REVISIONS
PLOT DATE	CHECKED	REVISIONS

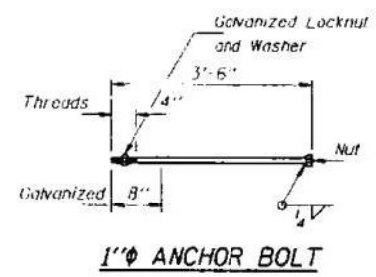

1" ANCHOR BOLT

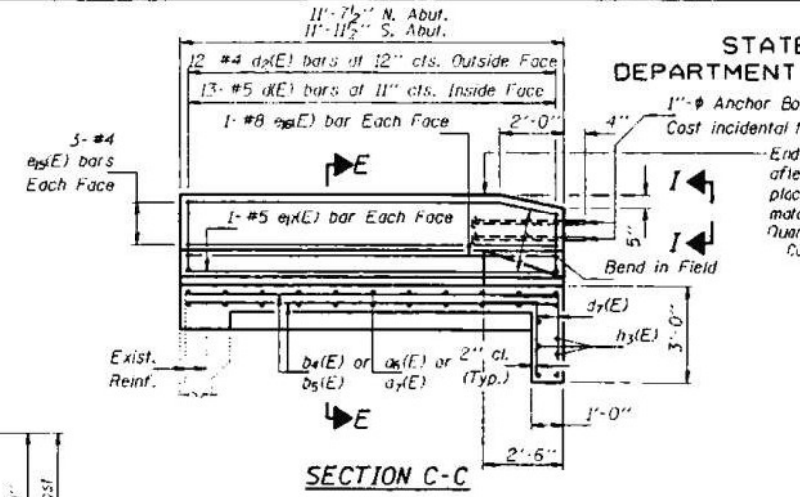

SECTION C-C

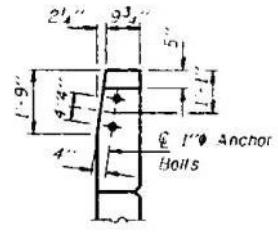

VIEW I-I

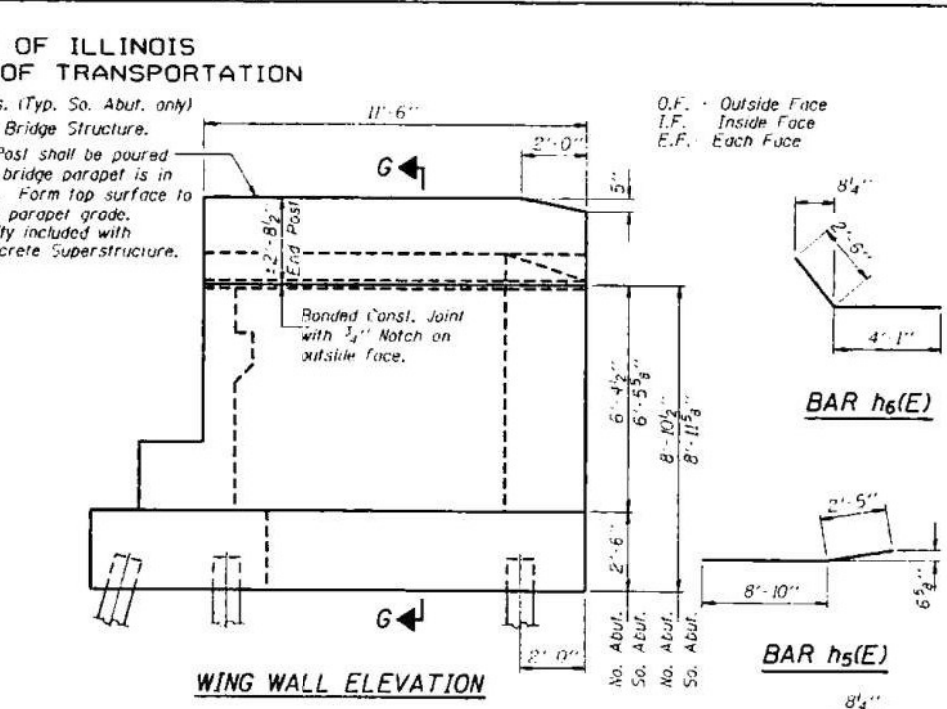

WING WALL ELEVATION

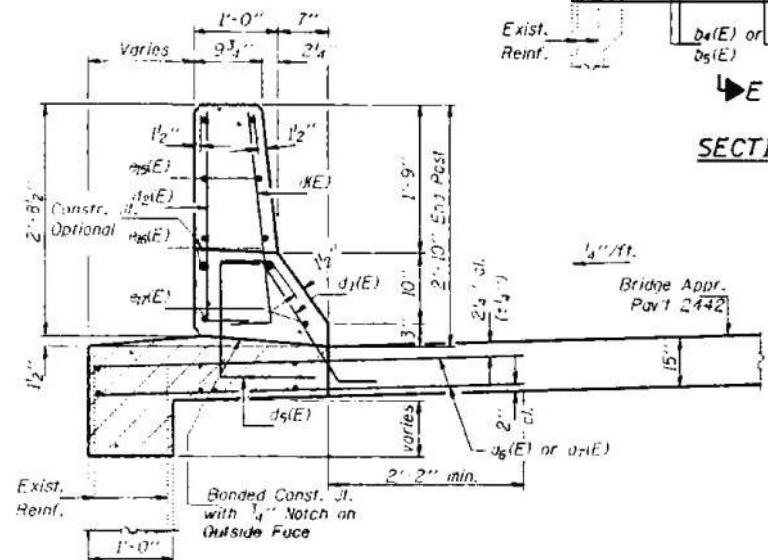

SECTION E-E

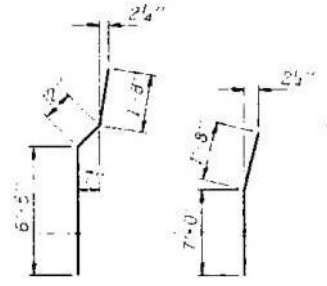

BAR v5(E) BAR v6(E)

BAR n(E)

BAR n1(E)

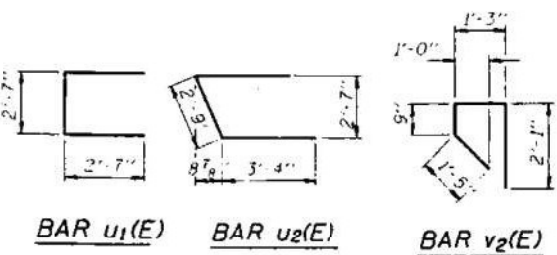

BAR u1(E)

BAR u2(E)

BAR v2(E)

BAR u3(E)

BAR u(E)

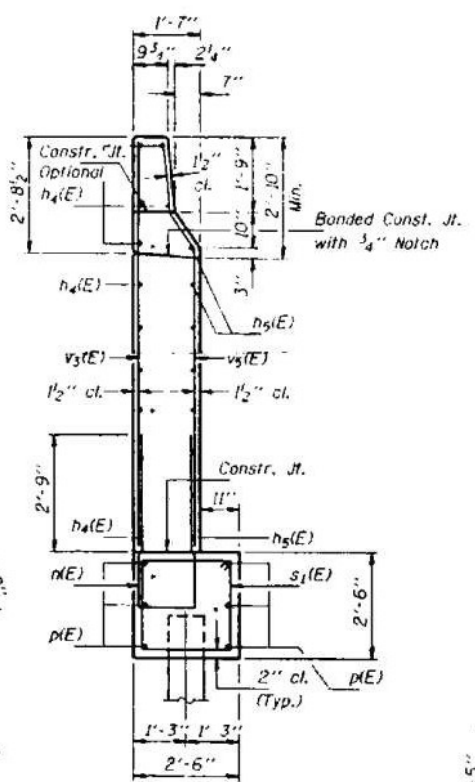

SECTION G-G

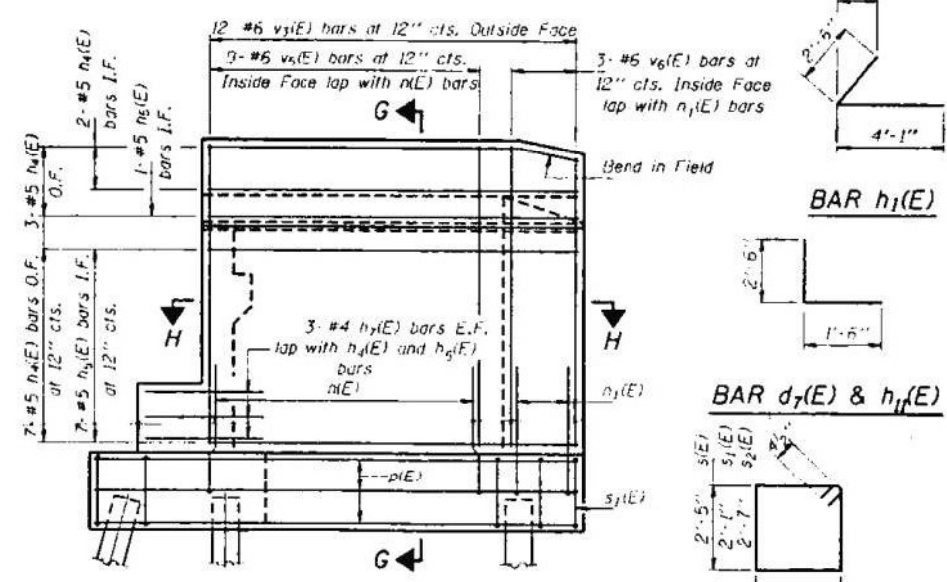

WING WALL ELEVATION Showing Reinforcement

BAR d7(E) & h1(E)

BARS s(E), s1(E) & s2(E)

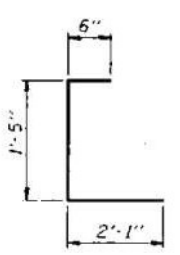

BAR d5(E)

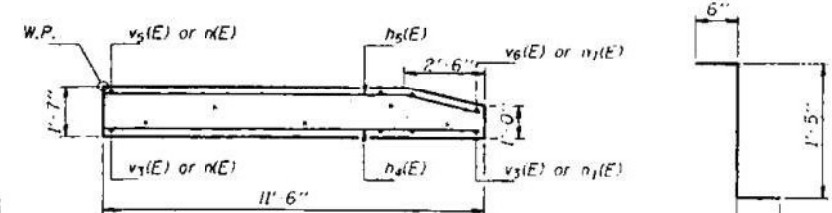

SECTION H-H

BAR d6(E)

For details of bars (RE) thru d2(E) see sheet #11 of 42.

TWO ABUTMENTS
 BILL OF MATERIAL

Bar	# N.A.	# S.A.	Size	Length	Shape	
a1(E)	22	20	#5	6'-9"		
a2(E)	22	20	#5	6'-11"		
b4(E)	8	8	#5	11'-4"		
b5(E)	13	13	#5	11'-3"		
c(E)	10	10	#5	3'-0"		
d1(L)	12	12	#4	3'-0"		
d2(E)	12	12	#4	4'-0"		
d3(E)	3	3	#5	6'-5"		
d4(E)	8	8	#4	1'-0"		
e5(E)	6	6	#4	1'-1"		
e6(E)	2	2	#8	11'-1"		
e7(E)	2	2	#5	11'-4"		
f(E)	22	22	#5	3'-0"		
g1(E)	4	10	#5	6'-7"		
g2(E)	4	4	#6	25'-10"		
h1(E)	6	6	#5	7'-9"		
h2(E)	12	12	#5	11'-3"		
h3(E)	8	8	#5	11'-3"		
h4(E)	10	4	#5	6'-7"		
h5(E)	6	6	#4	4'-2"		
h6(E)	4	4	#6	22'-1"		
h7(E)	6	6	#5	11'-6"		
h8(E)	2	2	#5	7'-0"		
h9(E)	2	2	#5	4'-3"		
i(E)	9	9	#6	2'-8"		
j1(E)	6	6	#6	4'-10"		
j2(E)	6	6	#7	14'-8"		
k(E)	7	7	#7	13'-3"		
k1(E)	7	7	#7	1'-10"		
l(E)	13	13	#4	10'-11"		
l1(E)	16	16	#4	9'-1"		
l2(E)	3	3	#4	1'-3"		
m(E)	22	22	#5	6'-2"		
n(E)	2	2	#5	5'-11"		
o(E)	49	49	#5	1'-11"		
p(E)	3	3	#6	2'-0"		
q(E)	3	3	#6	11'-6"		
r(E)	3	3	#6	8'-2"		
s(E)	24	16	#5	5'-11"		
s1(E)	28	18	#5	5'-0"		
s2(E)	12	11	#5	6'-6"		
t(E)	12	12	#6	9'-1"		
t1(E)	12	3	#5	2'-0"		
t2(E)	9	9	#6	9'-1"		
u(E)	3	3	#6	8'-8"		
v(E)	12	12	#5	12'-10"		
w1(E)	12	45	#5	8'-0"		
Concrete Structures					Cu. Yds.	31.4
Reinforcement Bars (Epoxy Coated)					Lbs.	6080
Concrete Piles					Foot	218
Test Piles Concrete					Each	2
Structure Excavation					Cu. Yds.	12

E. B. ABUTMENT DETAILS
 I-74 OVER A.T. & S.F. R.R.
 F.A.I. RTE. 74-SEC. (48-26VB)BY&BY-1
 KNOX COUNTY
 STATION 339+24.54

DESIGNED: [Signature]
 CHECKED: [Signature]
 DRAWN: [Signature]
 EXAMINED: [Signature]
 PASSED: [Signature]



STATE OF ILLINOIS
DEPARTMENT OF TRANSPORTATION

PROJECT NO.	48-26VB	SHEET NO.	55	TOTAL SHEETS	42 SHEETS
DATE	NOV 120	BY	55		

- Drill $\frac{1}{8}$ " ϕ x 9" Min. hole. Epoxy grout (NE) bars. Epoxy grout in accordance with Art 584 of the Standard Specifications. The method of grout application shall be approved by the Engineer.
- Bonded Construction Joint in accordance with Article 503.09(a)(2) of the Standard Specifications

E.F. Each Face

PILE DATA

Type: Concrete
Capacity: 35 tons
Est. Length: 46 Ft.
No. Required: 2

MIN. BAR LAPS

#5 (E) bars 2'-2"

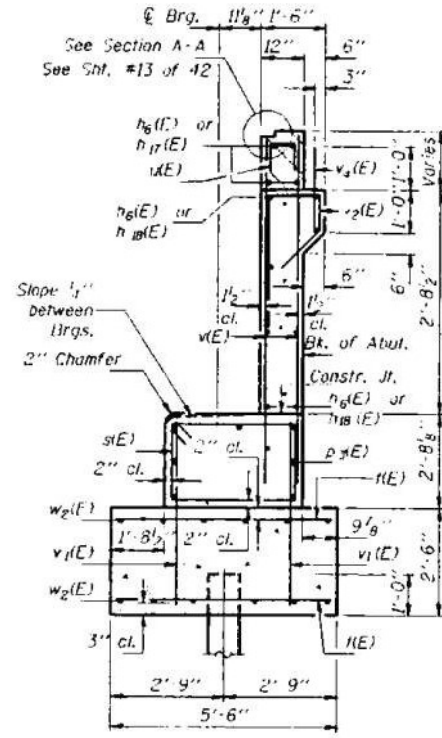

SECTION A-A

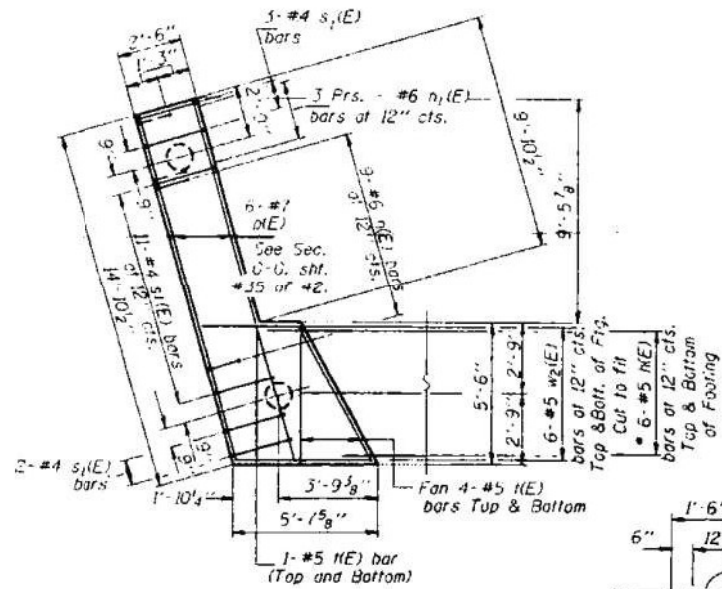

SECTION B-B

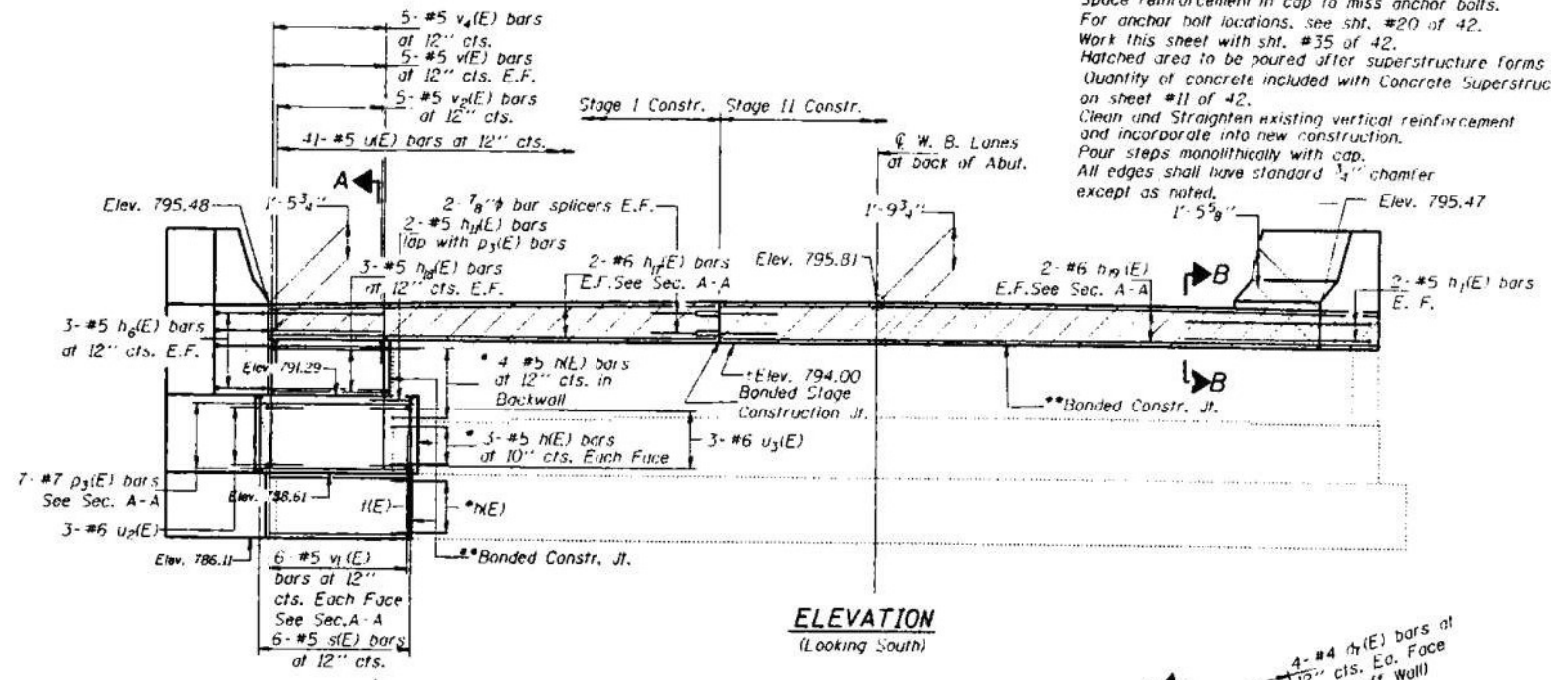

ELEVATION
(Looking South)

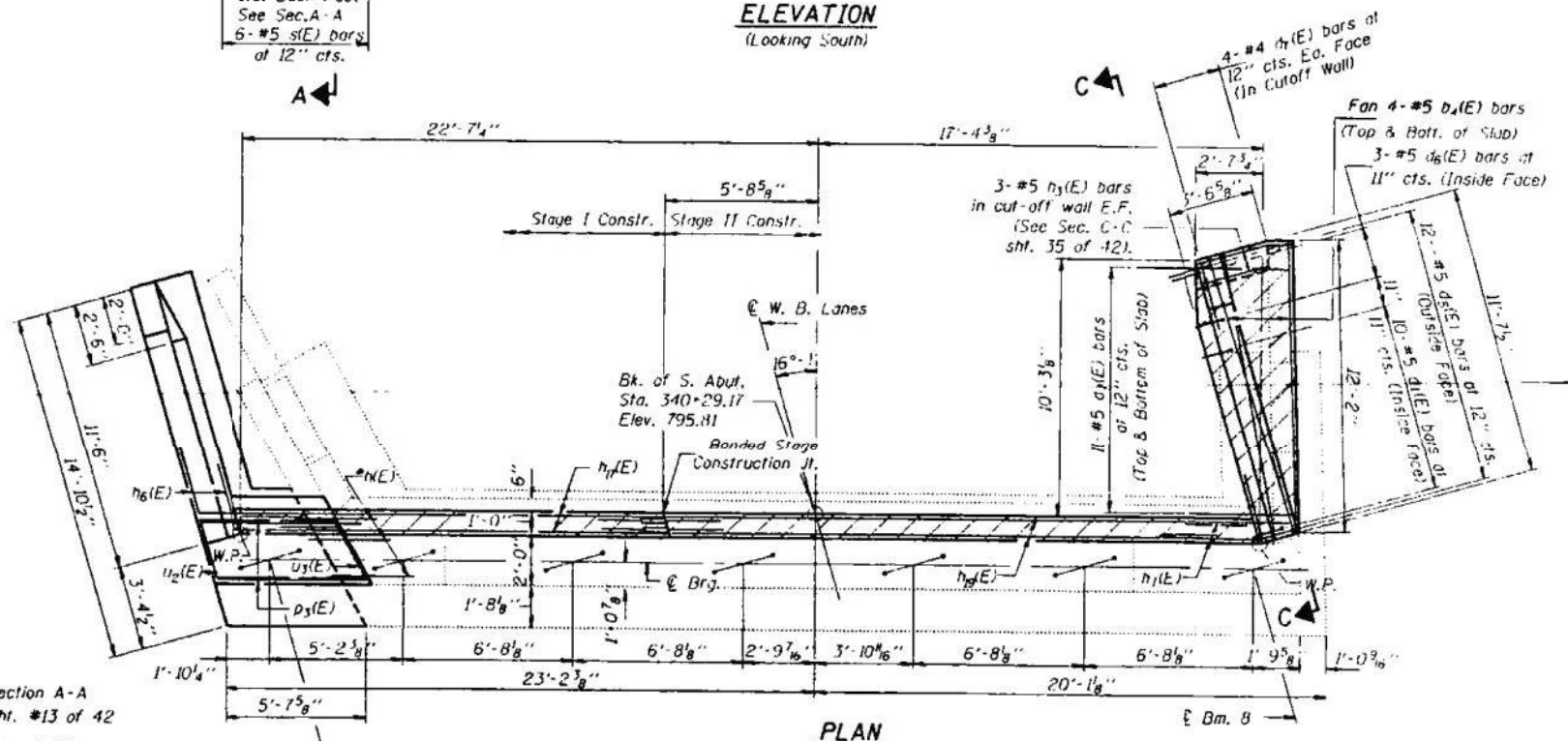

PLAN

Space reinforcement in cap to miss anchor bolts.
For anchor bolt locations, see sht. #20 of 42.
Work this sheet with sht. #35 of 42.
Hatched area to be poured after superstructure forms have been removed.
Quantity of concrete included with Concrete Superstructure on sheet #11 of 42.
Clean and Straighten existing vertical reinforcement and incorporate into new construction.
Pour steps monolithically with cap.
All edges shall have standard $\frac{1}{4}$ " chamfer except as noted.

W. B. SOUTH ABUTMENT
I-74 OVER A.T. & S.F. R.R.
F.A.I. RTE. 74-SEC. (48-26VB)BY&BY-1
KNOX COUNTY
STATION 339+24.54

DESIGNED	RBT
CHECKED	MJH
DRAWN	RBT
CHECKED	MJH

Aug. 25 1994
EXAMINED
PASSED

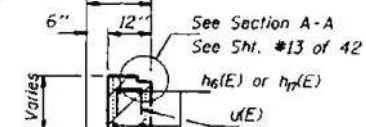

STATE OF ILLINOIS
DEPARTMENT OF TRANSPORTATION

EXISTING PLANS
S.N. 048-0008 (W.B.) & 048-0007 (E.B.)

F.A.I. RTE.	SECTION	COUNTY	TOTAL SHEETS	SHEET NO.
74	48(26VB)BY-1]BRR	KNOX	69	47
			CONTRACT NO. 68D83	

SHEET 28 OF 34 SHEETS

ILLINOIS FED. AID PROJECT



CIVIL DESIGN, INC.
WBE / DBE
EFFINGHAM, IL
LICENSE #184.003222

USER NAME	DESIGNED	REVISOR
	RBT	-
	CHECKED	MJH
	DRAWN	RBT
	CHECKED	MJH
PLOT SCALE		
PLOT DATE		

STATE OF ILLINOIS
DEPARTMENT OF TRANSPORTATION

PROJECT NO.	SECTION	COUNTY	SHEET	TOTAL SHEETS
F.A.I. 74 (48-26VB) BY&BY-1		KNOX	120	57
SHEET NO. 35				
12 SHEETS				

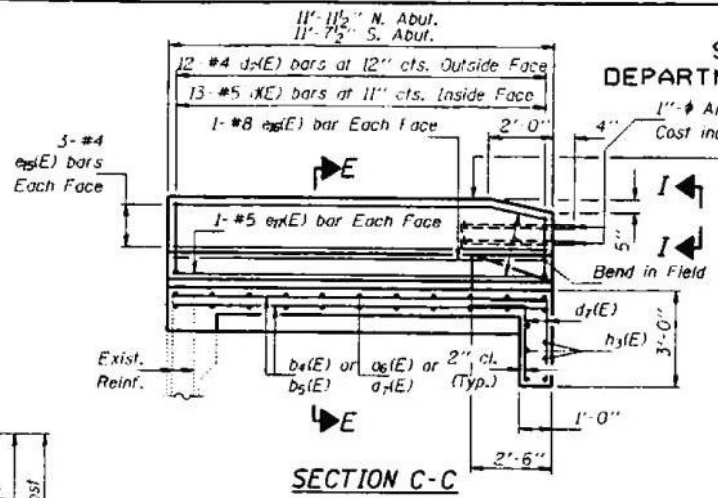
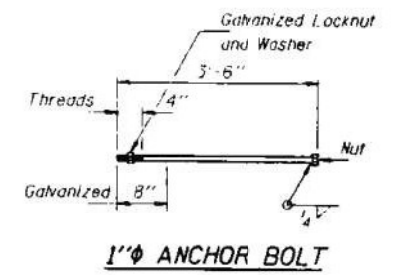

1" Anchor Bolts (Typ. No. Abut. only)
Cost incidental to Bridge Structure.
End Post shall be poured after bridge parapet is in place. Form top surface to match parapet grade. Quantity included with Concrete Superstructure.

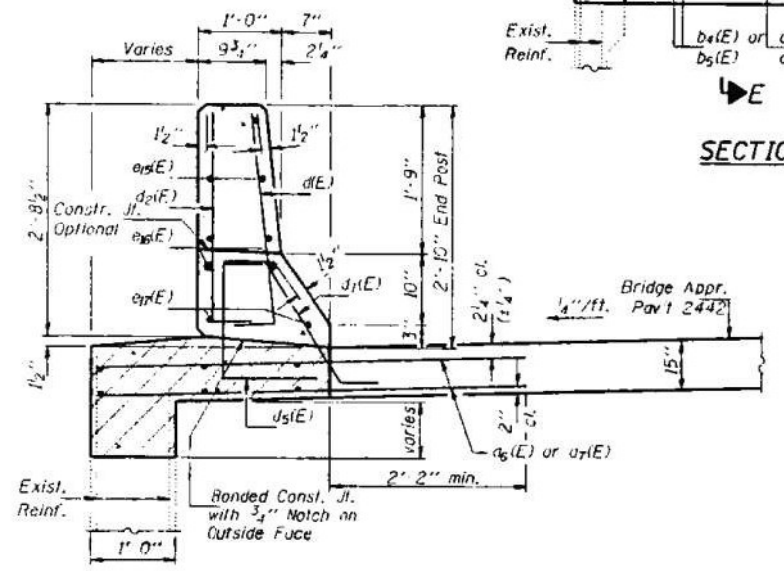
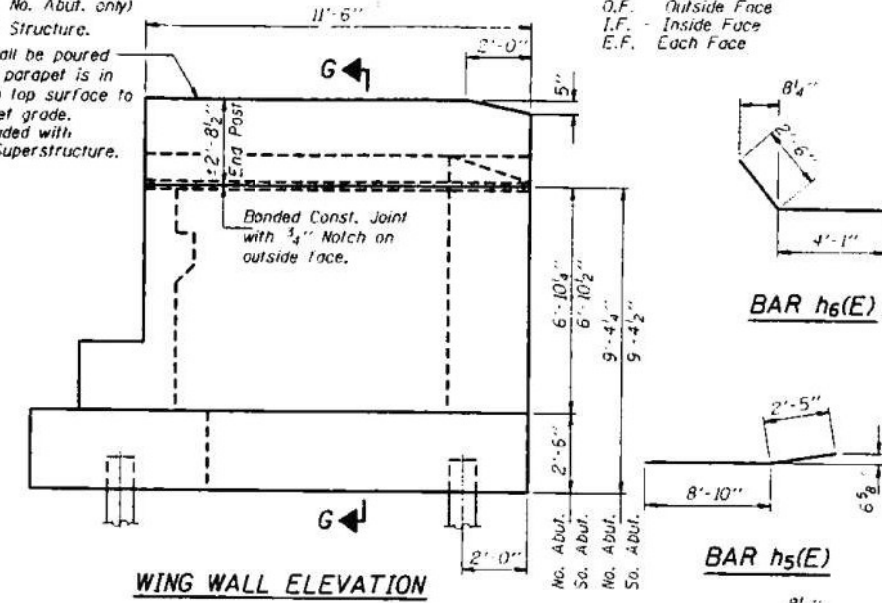

VIEW I-I

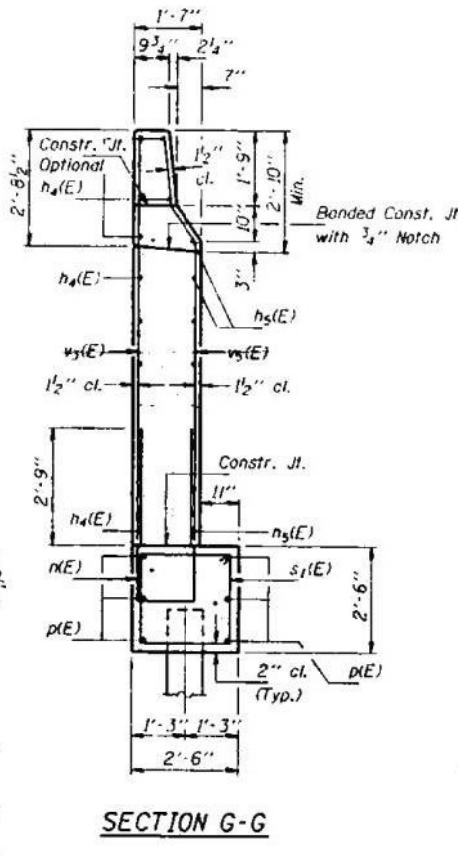
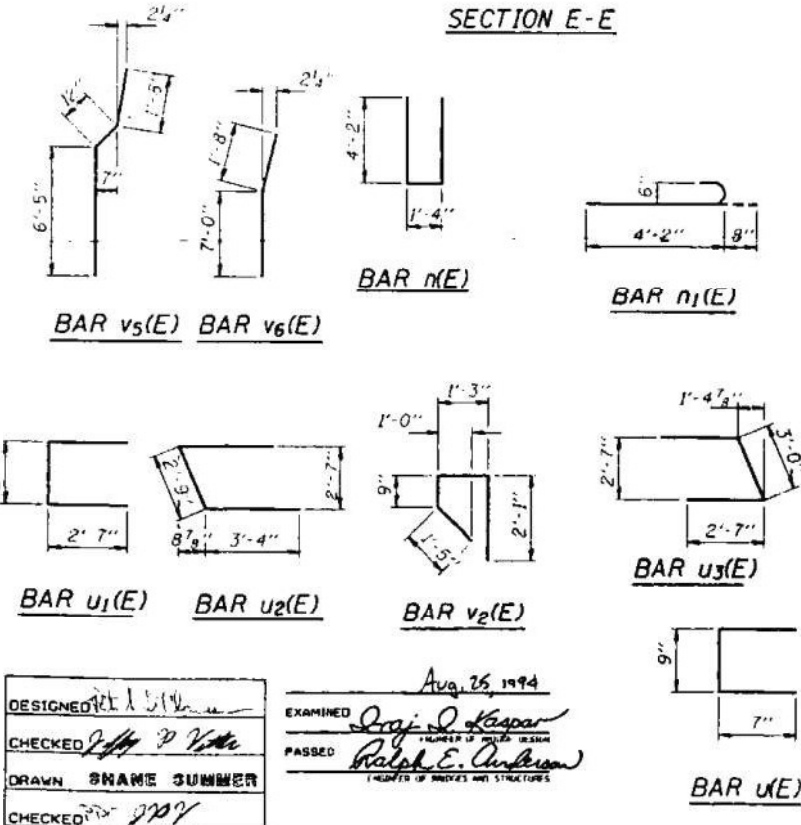
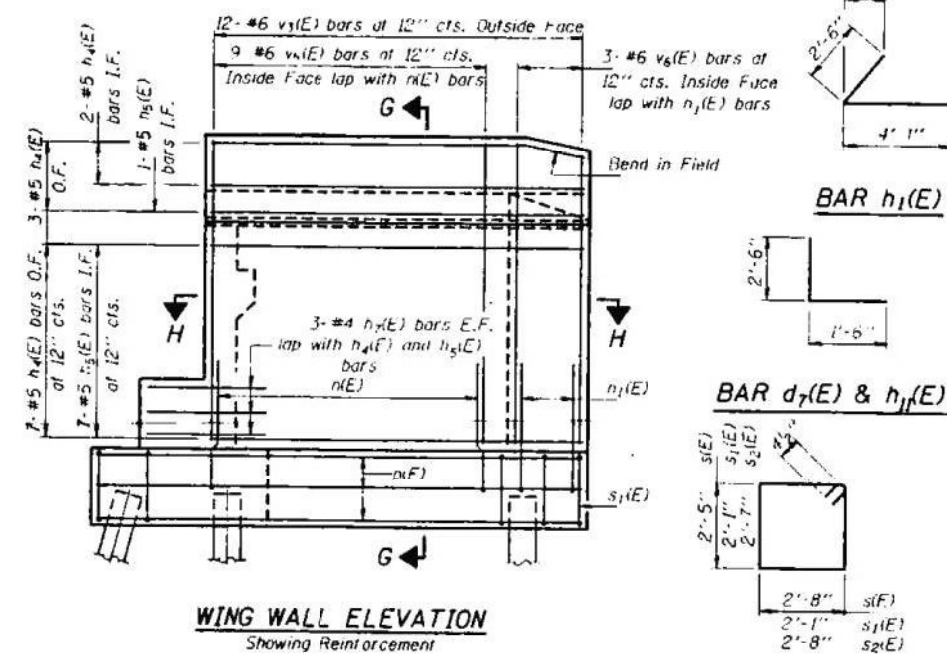

TWO ABUTMENTS
BILL OF MATERIAL

Bar	#N.A.	#S.A.	Size	Length	Shape
o6(E)	20		#5	6'-9"	
o7(E)		22	#5	6'-0"	
b4(E)		8	#5	11'-4"	
b4(E)	8		#5	11'-3"	
d1(E)	13	13	#5	3'-0"	
d1(F)	10	10	#5	2'-7"	
d2(E)	12	12	#4	3'-0"	
d3(E)	12	12	#4	4'-0"	
d4(E)	3	3	#5	2'-5"	
d4(E)	8	8	#4	4'-0"	
e6(E)	6	6	#4	11'-1"	
e6(E)	2	2	#8	11'-4"	
e7(E)	2	2	#5	11'-4"	
e8(E)	22	22	#5	3'-0"	
f1(E)	10	4	#5	6'-7"	
f1(E)	6	6	#5	2'-9"	
f2(E)	12	12	#5	11'-3"	
f3(E)	8	8	#5	11'-3"	
f4(E)	4	10	#5	6'-7"	
f5(E)	6	6	#4	4'-2"	
f6(E)	2	2	#5	4'-0"	
f7(E)	4	4	#5	16'-11"	
f8(E)	3	3	#5	3'-10"	
f9(E)	4	4	#5	22'-3"	
g(E)	9	9	#6	9'-8"	
h1(E)	6	6	#6	4'-10"	
h2(F)	6	6	#6	14'-8"	
h3(E)	7	7	#7	5'-1"	
s1(E)		6	#4	10'-11"	
s1(E)	16	16	#4	9'-1"	
s2(E)	6	6	#4	11'-3"	
h(E)	8	10	#5	5'-2"	
u(E)	41	41	#5	1'-11"	
u1(F)	3	3	#6	7'-9"	
u2(F)	3	3	#6	8'-5"	
u3(F)	3	3	#5	8'-2"	
v1(F)	8	10	#5	5'-11"	
v1(E)	12	12	#5	5'-0"	
v2(E)	4	5	#5	5'-6"	
v3(E)	12	12	#5	3'-1"	
v4(E)	4	5	#5	2'-0"	
v4(E)	9	9	#6	3'-1"	
v6(E)	3	3	#6	8'-8"	
w2(E)	12	12	#5	5'-4"	
Concrete Structures					
Reinforcement Bars (Epoxy Coated)					
Concrete Piles					
Structure Excavation					
			Cu. Yds.	22.5	
			Lbs.	5080	
			Foos	176	
			Cu. Yds.	55	

W. B. ABUTMENT DETAILS
I-74 OVER A.T. & S.F. R.R.
F.A.I. RTE. 74-SEC. (48-26VB)BY&BY-1
KNOX COUNTY
STATION 339+24.54

DESIGNED: [Signature]
CHECKED: [Signature]
DRAWN: SNAME SUMMER
CHECKED: [Signature]

EXAMINED: [Signature]
PASSED: [Signature]

Aug. 26, 1994

STATE OF ILLINOIS
DEPARTMENT OF TRANSPORTATION

EXISTING PLANS
S.N. 048-0008 (W.B.) & 048-0007 (E.B.)

F.A.I. RTE.	SECTION	COUNTY	TOTAL SHEETS	SHEET NO.
74	48(26VB)BY&BY-1]BR	KNOX	69	49
CONTRACT NO. 68D83				
ILLINOIS FED. AID PROJECT				

MODEL: Default
FILE NAME: P:\Effingham\4852 - IDOT FTB 198-018_D4_VVAWork Order #10Z Rehab WO 10 RT130 Existing.dgn
10/19/2023 4:05:12 PM

STATE OF ILLINOIS
DEPARTMENT OF TRANSPORTATION

PROJECT NO.	SECTION	COUNTY	SHEET	TOTAL SHEETS
F.A.I. RTE. 74 (48-26VB) BY&BY-1	KNOX	120	53	42 SHEETS

Space reinforcement in cap to miss anchor bolts.
For anchor bolt locations, see sht. #20 of 42.
Work this sheet with sht. #32 of 42.
Hatched area to be poured after superstructure forms have been removed.
Quantity of concrete included with Concrete Superstructure on sheet #11 of 42.
Clean and Straighten existing vertical reinforcement and incorporate into new construction.
Pour steps monolithically with cap.
All edges shall have standard 3/4" chamfer except as noted.

- Drill 7/8" x 9" Min. hole. Epoxy grout h(E) bars. Epoxy grout in accordance with Art 584 of the Standard Specifications. The method of grout application shall be approved by the Engineer.
- Bonded Construction joint in accordance with Article 503.00(a)(2) of the Standard Specifications

C.F. - Each Face

PILE DATA
Type: Concrete
Capacity: 55 Tons
Est. Length: 42 Ft.
No. Required: 5 * 1 Test Pile

MIN. BAR LAPS
#5 (E) bars = 2'-2"

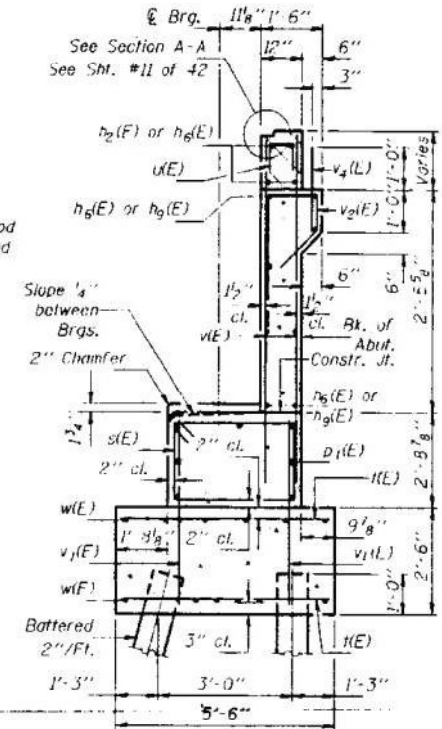

SECTION A-A

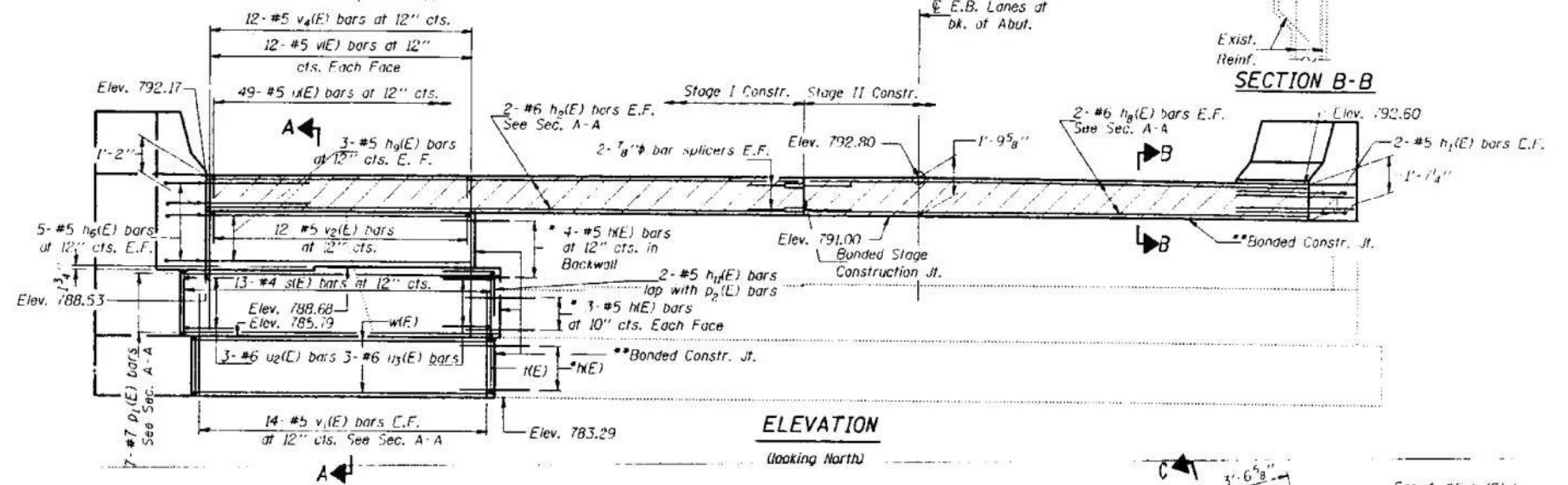

ELEVATION
(Looking North)

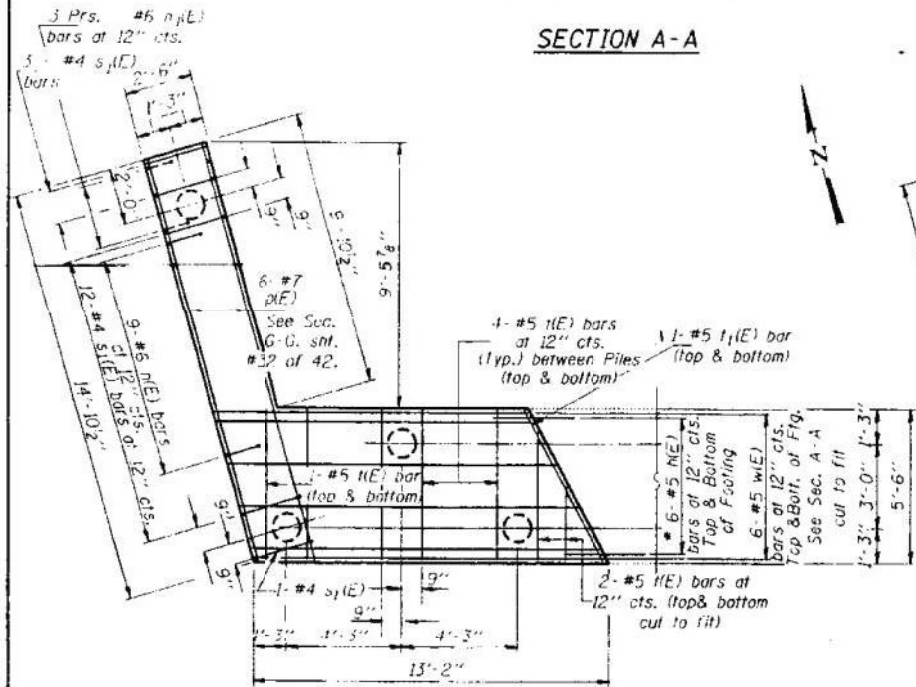

SECTION B-B

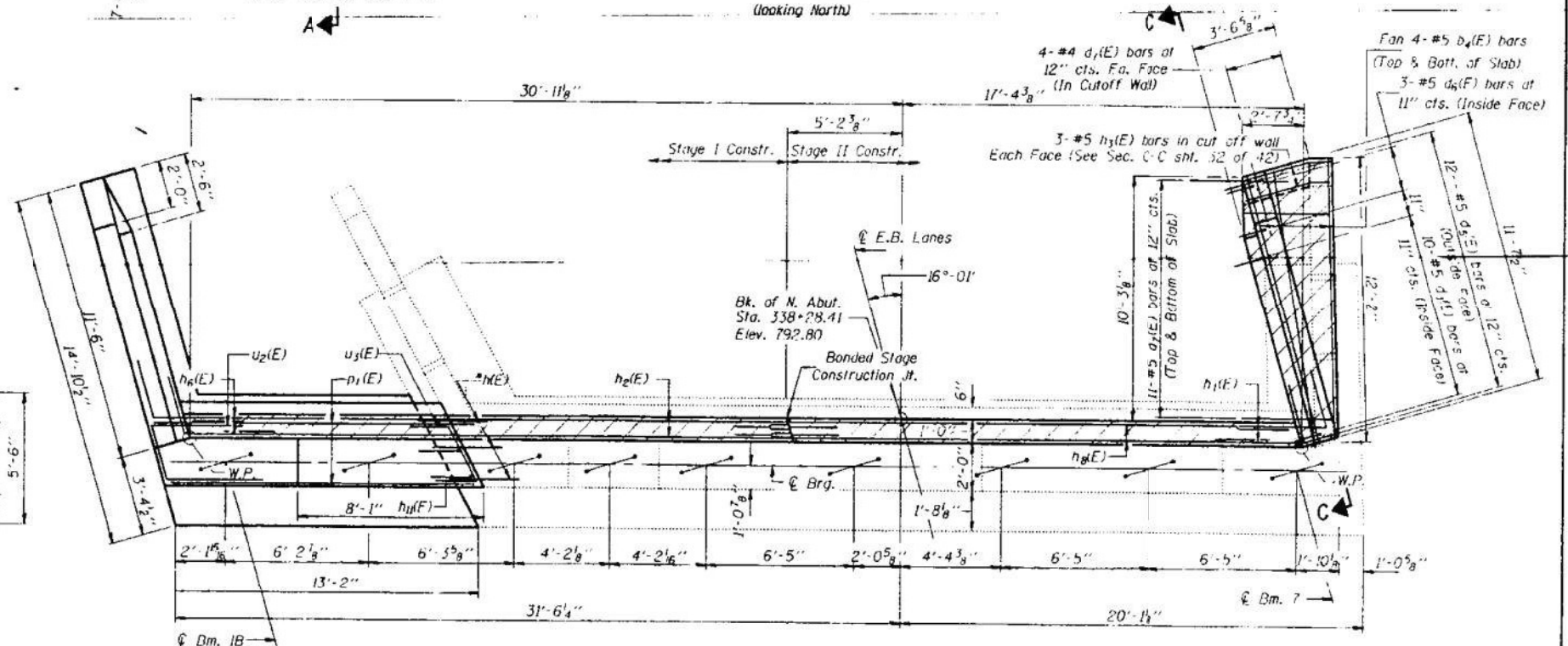

PLAN

DESIGNED: *[Signature]*
CHECKED: *[Signature]*
DRAWN: *[Signature]*
CHECKED: *[Signature]*

EXAMINED: *[Signature]*
PASSED: *[Signature]*

Aug. 25, 1994

E. B. NORTH ABUTMENT
I-74 OVER A.T. & S.F. R.R.
F.A.I. RTE. 74-SEC. (48-26VB)BY&BY-1
KNOX COUNTY
STATION 339+24.54

STATE OF ILLINOIS
DEPARTMENT OF TRANSPORTATION

EXISTING PLANS
S.N. 048-0008 (W.B.) & 048-0007 (E.B.)

F.A.I. RTE.	SECTION	COUNTY	TOTAL SHEETS	SHEET NO.
74	48((26VB)BY,BY-1)BRR	KNOX	69	50
			CONTRACT NO. 68D83	

SHEET 31 OF 34 SHEETS

ILLINOIS FED. AID PROJECT

MODEL: Default
FILE NAME: P:\Effingham\4852 - IDOT FTB 198-018_D4_VVAWork Order #102 Rehab WO 10 RT31 Existing.dgn



CIVIL DESIGN, INC.
WBE / DBE
EFFINGHAM, IL
LICENSE #184.003222

USER NAME	DESIGNED	REVISION
	RBT	
	CHECKED	MJH
	DRAWN	RBT
	CHECKED	MJH

10/19/2023 4:06:03 PM

STATE OF ILLINOIS
DEPARTMENT OF TRANSPORTATION

DATE	BY	CHECKED	SCALE	SHEET NO.
7.1.74	(48-26VB) BTBY-1	KNOX	120 58	42 SHEETS

Notes: Space reinforcement in cap to miss anchor bolts.
For anchor bolt locations, see sht. #19 of 42.
Pour steps monolithically with cap.
All edges shall have standard 3/4" chamfer except as noted.

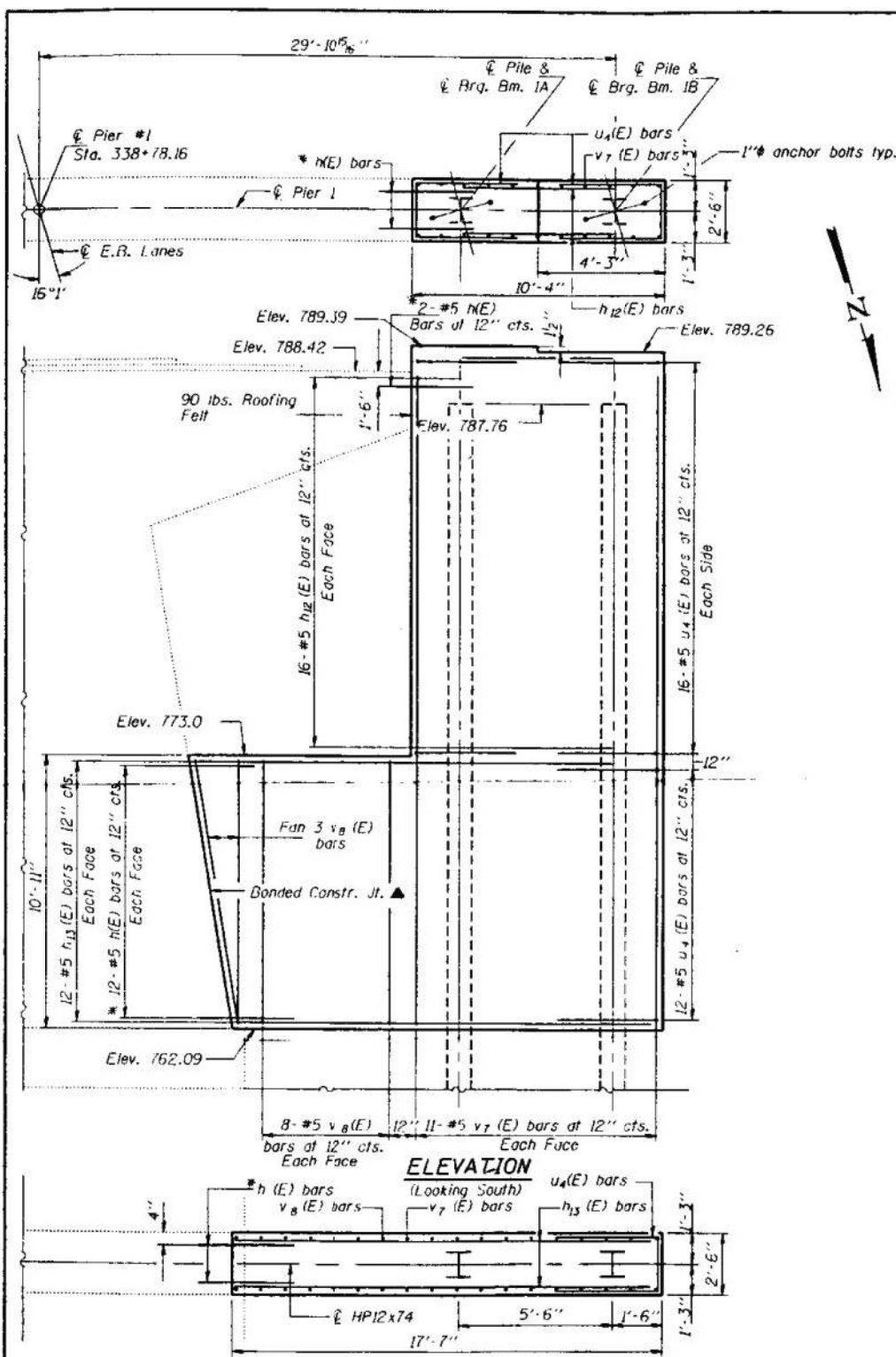

PIER 1

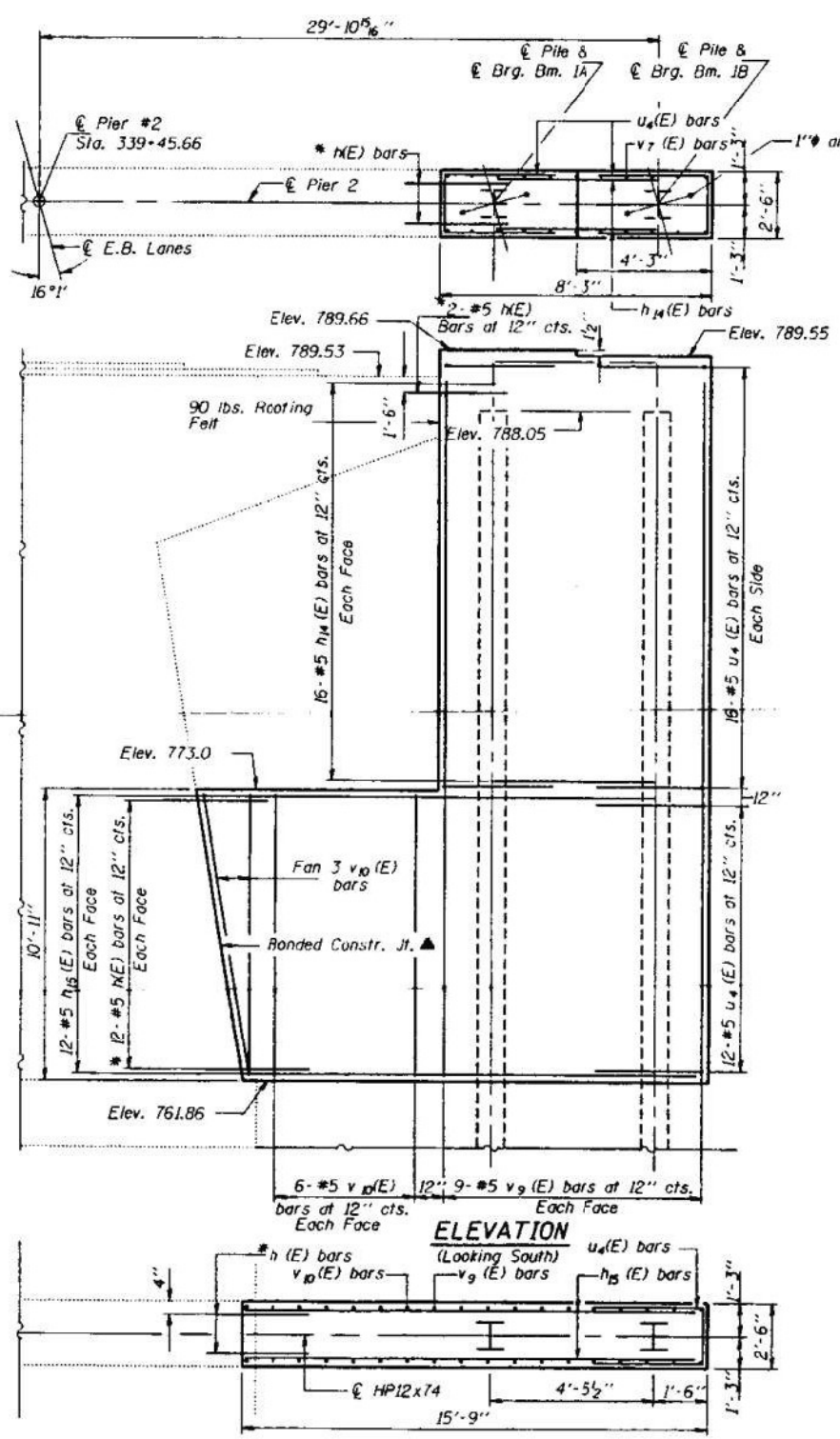

PIER 2

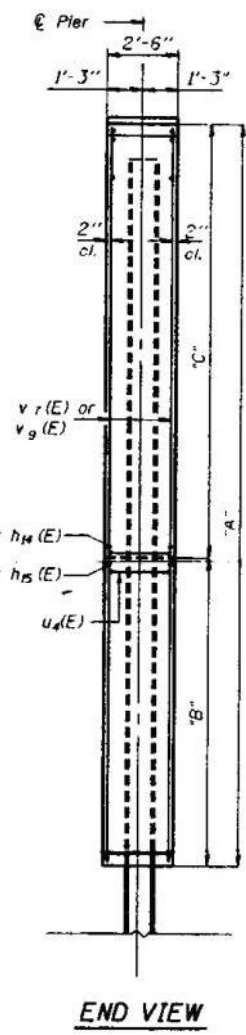

END VIEW

	A	B	C
Pier 1	27'-2"	10'-11"	16'-3"
Pier 2	27'-8 1/2"	11'-1 1/2"	16'-6 1/2"

PIER DIMENSIONS

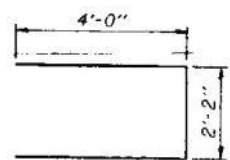

u4(E) BAR

BILL OF MATERIAL

Bar	No.	Size	Length	Shape
NE	52	#5	3'-0"	
h12(E)	32	#5	10'-0"	
h13(E)	24	#5	17'-4"	
h14(E)	32	#5	7'-11"	
h15(E)	24	#5	15'-6"	
v7(L)	22	#5	26'-10"	
v8(E)	18	#5	10'-7"	
v9(E)	18	#5	27'-4"	
v10(E)	18	#5	10'-10"	
u4(E)	88	#5	10'-2"	
Concrete Structures		Cu. Yd.	64.2	
Reinforcement Bars, Epoxy Coated		Lbs.	4,050	
Structure Excavation		Cu. Yd.	39	
Steel Piles HP12 x 74		Foot	198	
Test Piles HP12 x 74		Each	1	

Reinforcement Bars designated (E) shall be epoxy coated.

PILE DATA

Type: HP 12 x 74
Capacity: Drive to Refusal
Est. Length: 66'
No. Required: 1 + 1 Test Pile (Pier 1)
2 (Pier 2)

MIN. BAR LAPS

#5 (E) bars = 2'-2"

E.B.L. PIERS #1 & #2
I-74 OVER A.T. & S.F. R.R.
F.A.I. RTE. 74-SEC. (48-26VB)BY&BY-1
KNOX COUNTY
STATION 339+24.54

DESIGNED: [Signature]
CHECKED: [Signature]
DRAWN: SHANE SUMNER
CHECKED: [Signature]

EXAMINED: [Signature]
PASSED: [Signature]

Aug. 25, 1994

* Drill 7/8" x 9" Min. hole. Epoxy grout NE bars. Epoxy grout in accordance with Art. 584 of the Standard Specifications. The method of grout application shall be approved by the Engineer.
▲ Bonded Construction Joint in accordance with Article 503.09a(2) of the Standard Specifications

MODEL: Default
FILE NAME: P:\Effingham\4852 - IDOT FTB 198-018_D4_VVAWork Order #101 Rehab WO 10 RT132 Existing.dgn
10/19/2023 4:06:55 PM



CIVIL DESIGN, INC.
WBE / DBE
EFFINGHAM, IL
LICENSE #184.003222

USER NAME	DESIGNED	REVISION
	CHECKED	REVISION
	DRAWN	REVISION
	CHECKED	REVISION

STATE OF ILLINOIS
DEPARTMENT OF TRANSPORTATION

EXISTING PLANS
S.N. 048-0008 (W.B.) & 048-0007 (E.B.)

SHEET 32 OF 34 SHEETS

F.A.I. RTE.	SECTION	COUNTY	TOTAL SHEETS	SHEET NO.
74	48(26VB)BY-1]BR	KNOX	69	51
			CONTRACT NO. 68D83	

ILLINOIS FED. AID PROJECT

LIGHTING CONSTRUCTION NOTES

1.	THE LOCATION OF ALL UTILITIES AND PRIVATELY OWNED FACILITIES SHALL BE FIELD VERIFIED BY THE CONTRACTOR PRIOR TO THE INSTALLATION OF ANY COMPONENTS.
2.	THE CONTRACTOR SHALL BE RESPONSIBLE FOR LOCATING EXISTING IDOT ELECTRICAL FACILITIES AT HIS/HER OWN EXPENSE IF REQUIRED. THE CONTRACTOR SHALL ALSO BE LIABLE FOR ANY DAMAGE TO IDOT FACILITIES RESULTING FROM INACCURATE LOCATING.
3.	ELECTRICAL WORK SHALL CONFORM WITH NATIONAL, STATE, AND LOCAL CODES.
4.	THE CONTRACTOR SHALL PROVIDE ELECTRICAL CABLE SLACK IN ACCORDANCE WITH ARTICLES 817.04 AND 873.03.
5.	ALL SURPLUS MATERIALS SHALL BE DISPOSED OF IN ACCORDANCE WITH ARTICLE 202.03 OF THE STANDARD SPECIFICATIONS.
6.	THE CONTRACTOR SHALL VERIFY FIELD CONDITIONS PRIOR TO BIDDING. THERE WILL BE NO ADDITIONAL COMPENSATION PAID FOR CLAIMS THAT ARISE FROM A FAILURE TO FULLY INVESTIGATE EXISTING FIELD CONDITIONS.
7.	THE CONTRACTOR SHALL VERIFY LUMINAIRE VOLTAGE PRIOR TO ORDERING MATERIALS.
8.	ALL LIGHTING EQUIPMENT SHALL BE BONDED IN ACCORDANCE WITH NEC REQUIREMENTS.
9.	REMOVAL OF EXISTING ITEMS (LIGHT POLES, BREAKAWAY COUPLINGS, LUMINAIRES, WIRING, LIGHTING CONTROLLER, ETC.) WILL NOT BE PAID FOR SEPARATELY, BUT SHALL BE INCLUDED IN THE BID PRICE FOR THE PROPOSED ITEMS.
10.	THE CONTRACTOR SHALL FURNISH AND INSTALL NEW FUSEHOLDERS, FUSES, SURGE ARRESTORS, AND WIRING FOR EACH PROPOSED LUMINAIRE IN ACCORDANCE WITH HIGHWAY STANDARD 821101-02. THE COST OF THIS WORK SHALL BE INCLUDED IN THE PRICE OF THE PROPOSED LUMINAIRES.
11.	THE CONTRACTOR SHALL REMOVE THE HPS LAMPS FROM THE EXISTING FIXTURES PRIOR TO DISPOSAL. THE HPS LAMPS SHALL BE DISPOSED OF AT A CERTIFIED RECYCLING FACILITY. THE COST OF THIS WORK SHALL BE INCLUDED IN THE BID PRICE FOR THE PROPOSED LED LUMINAIRES.
12.	THE CONTRACTOR SHALL FURNISH AND INSTALL NEW BREAKWAY COUPLINGS IN ACCORDANCE WITH THE MANUFACTURER'S RECOMMENDATIONS. THE CONTRACTOR SHALL FURNISH ALL HARDWARE AND OTHER ITEMS REQUIRED FOR INSTALLATION OF THE BREAKAWAY COUPLINGS. THE COST OF THIS WORK SHALL BE INCLUDED IN THE PAY ITEM "BREAKAWAY DEVICE, COUPLING WITH STAINLESS STEEL SCREEN."
13.	THE CONTRACTOR SHALL FURNISH AND INSTALL NEW STAINLESS STEEL OR PERFORATED ALUMINUM SCREENING AROUND THE PROPOSED LIGHT POLES AS SHOWN IN THE PLANS. THE PROPOSED SCREEN SHALL BE SECURELY BANDED ON THE TOP AND BOTTOM OF THE BREAKAWAY COUPLINGS TO PREVENT RODENT ENTRY AND NO GAPS IN EXCESS OF 0.25 INCH WILL BE ALLOWED. THE COST OF THIS WORK SHALL BE INCLUDED IN THE PAY ITEM "BREAKAWAY DEVICE, COUPLING WITH STAINLESS STEEL SCREEN."
14.	THE CONTRACTOR SHALL FURNISH AND INSTALL NEW STAINLESS STEEL OR PERFORATED ALUMINUM SCREENING AROUND THE EXISTING LIGHT POLES AS SHOWN IN THE PLANS. THE PROPOSED SCREEN SHALL BE SECURELY BANDED ON THE TOP AND BOTTOM OF THE BREAKAWAY COUPLINGS TO PREVENT RODENT ENTRY AND NO GAPS IN EXCESS OF 0.25 INCH WILL BE ALLOWED. THE COST OF THIS WORK SHALL BE INCLUDED IN THE PAY ITEM "FURNISH AND INSTALL METAL SCREEN."
15.	EXISTING UNIT-DUCT, ELECTRIC SERVICE, ELECTRICAL CABLING LIGHTING CONTROLLER FOUNDATION, AND LIGHT POLE FOUNDATIONS SHALL BE RE-USED WITH THE PROPOSED LIGHTING INSTALLATION.
16.	THE CONTRACTOR SHALL FURNISH AND INSTALL THE PROPOSED LIGHTING CONTROLLER ON THE EXISTING CONCRETE FOUNDATION.
17.	THE EXISTING LIGHTING SYSTEM SHALL REMAIN IN OPERATION DURING THE INSTALLATION OF THE PROPOSED ITEMS.
18.	THE INSTALLATION OF STAINLESS STEEL SCREEN AROUND ANCHOR RODS AND NUTS SHALL BE DONE ACCORDING TO ARTICLE 1070.
19.	THE CONTRACTOR MAY ELECT TO FURNISH AND INSTALL PERFORATED ALUMINUM SCREENING IN LEIU OF STAINLESS STEEL SCREEN AT NO ADDITONAL COST TO THE DEPARTMENT.
20.	THE CONTRACTOR SHALL FURNISH AND INSTALL THE CCTV DOME CAMERA ASSEMBLY, CAMERA BRACKET AND ALL OTHER ITEMS REQUIRED FOR INSTALLATION AND OPERATION ON THE EXISTING CAMERA POLE, AS SHOWN IN THE PLANS. THE EXISTING CAT 5 CABLE WILL BE RE-USED. THIS WORK WILL NOT BE PAID FOR SEPARATELY, BUT SHALL BE INCLUDED IN THE BID PRICE FOR THE CLOSED CIRCUIT TELEVISION DOME CAMERA, HD.
21.	THE CONTRACTOR SHALL REMOVE AND DELIVER THE EXISTING CCTV CAMERA TO THE IDOT TRAFFIC BUILDING LOCATED AT 1025 W. DETWEILLER DR., PEORIA, IL. THE COST OF THIS WORK WILL NOT BE PAID FOR SEPARATELY, BUT SHALL BE INLCUDED IN THE BID PRICE FOR THE CLOSED CIRCUIT TELEVISION DOME CAMERA, HD.
22.	THE CONTRACTOR SHALL MAKE MINOR REPAIRS TO THE EXISTING CONDUIT ATTACHED TO STRUCTURE AND ASSOCIATED FITTINGS AS NEEDED. THIS WORK WILL BE PAID FOR AS EXTRA WORK IN ACCORDANCE WITH ARTICLE 109.04 OF THE STANDARD SPECIFICATIONS.

MODEL NUMBER
FILE NAME: SHEETS

USER NAME = \$USERS	DESIGNED -	REVISED -
	DRAWN -	REVISED -
PLOT SCALE = \$SCALES	CHECKED -	REVISED -
PLOT DATE = \$DATES	DATE -	REVISED -

**STATE OF ILLINOIS
DEPARTMENT OF TRANSPORTATION**

**LIGHTING CONSTRUCTION NOTES
I-74 & MAIN ST. INTERCHANGE - GALESBURG**

SCALE: SHEET OF SHEETS STA. TO STA.

F.A.I. RTE.	SECTION	COUNTY	TOTAL SHEETS	SHEET NO.
74	48(126VB)BY-BY-11BRR	KNOX	69	54
			CONTRACT NO. 68D83	
		ILLINOIS FED. AID PROJECT		

FOR REFERENCE ONLY

LEGEND	DESCRIPTION	UNIT	QUANTITY TOTALS
---	UNIT DUCT, 2-600 V. XLP #6, 1" POLYETHYLENE	LIN. FT.	5660
---	UNIT DUCT, 2-600 V. XLP #2, 1" POLYETHYLENE	LIN. FT.	1455
---	BARE COPPER WIRE, 1/C #6	LIN. FT.	7305
---	TRENCH & BACKFILL FOR ROADWAY LIGHTING	LIN. FT.	6344
---	CONDUIT ATTACHED TO STRUCTURE, 2" DIA. GALV. STEEL	LIN. FT.	50
---	ELECTRIC CABLE IN CONDUIT, 600 V. (XLP TYPE USE) 1/C #6	LIN. FT.	380
---	ELECTRIC CABLE IN CONDUIT, 600 V. (XLP TYPE USE) 1/C #12	LIN. FT.	2700
---	CONDUIT PUSHED, 2" DIA. INTERMEDIATE METAL	LIN. FT.	290
---	CONDUIT PUSHED, 3" DIA. INTERMEDIATE METAL	LIN. FT.	52
---	LIGHT POLE FOUNDATION	EACH	21
---	LIGHT POLE STEEL, 45' M.H. TENON MOUNT	EACH	18
---	LIGHT POLE STEEL, 45' M.H. TENON MOUNT-TWIN	EACH	3
---	LUMINAIRE, SODIUM VAPOR, MULTI-MOUNT, 250 WATT	EACH	24
---	CONTROL INSTALLATION TYPE CB-RCS-60-240 V.	EACH	1
---	SIGN LIGHTING (HPS)	LIN. FT.	94

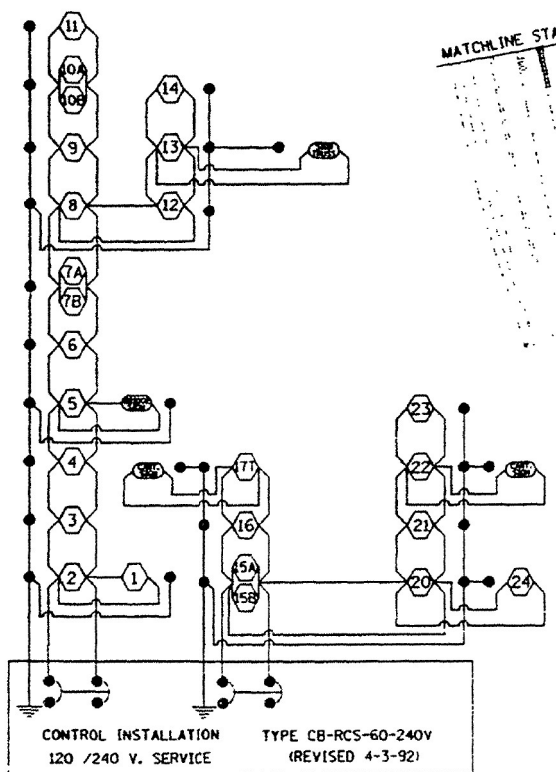
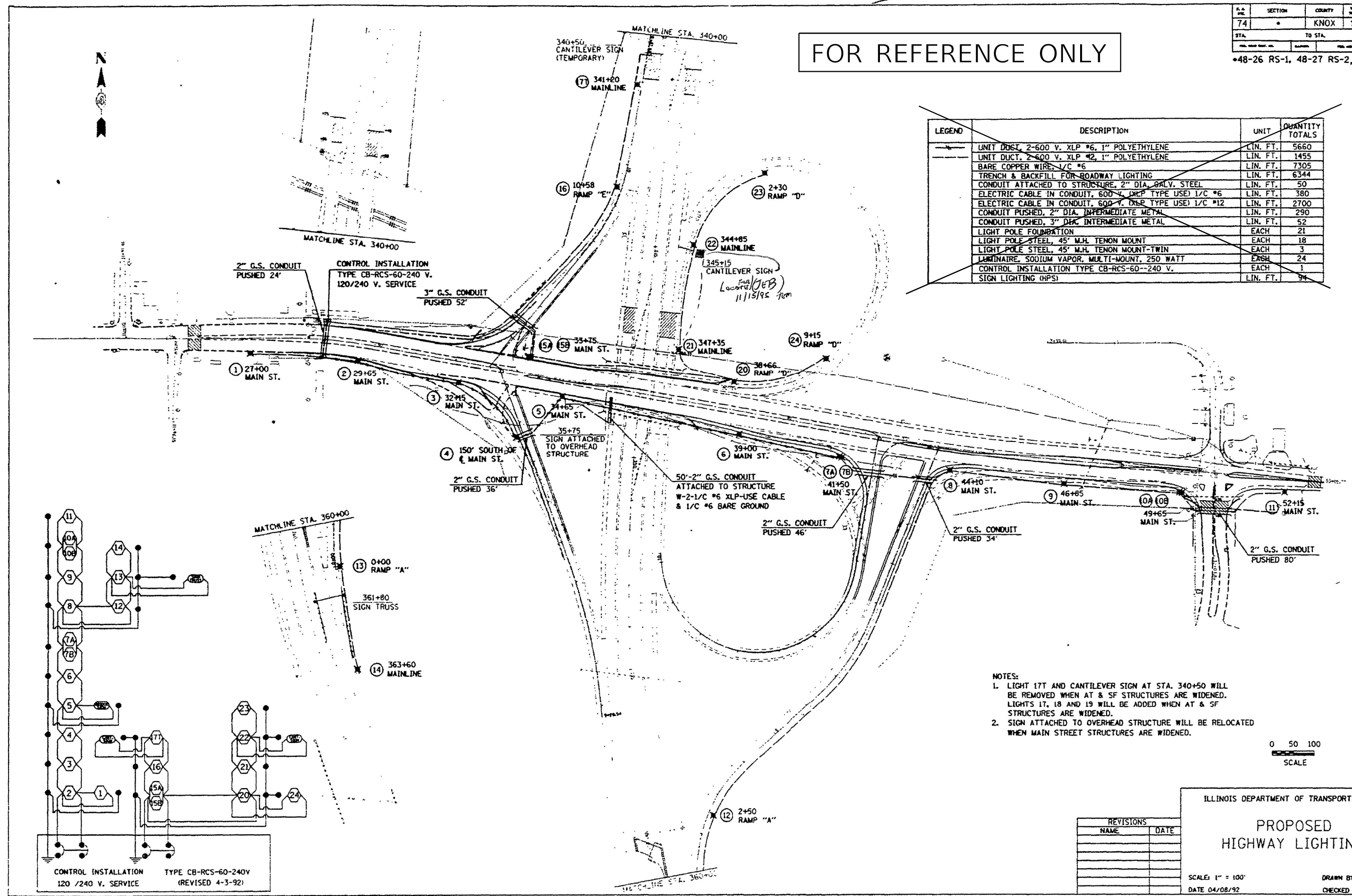

- NOTES:
- LIGHT 17T AND CANTILEVER SIGN AT STA. 340+50 WILL BE REMOVED WHEN AT & SF STRUCTURES ARE WIDENED. LIGHTS 17, 18 AND 19 WILL BE ADDED WHEN AT & SF STRUCTURES ARE WIDENED.
 - SIGN ATTACHED TO OVERHEAD STRUCTURE WILL BE RELOCATED WHEN MAIN STREET STRUCTURES ARE WIDENED.

0 50 100
SCALE

REVISIONS	
NAME	DATE

ILLINOIS DEPARTMENT OF TRANSPORTATION

PROPOSED HIGHWAY LIGHTING

SCALE: 1" = 100'

DATE 04/08/92

DRAWN BY CADDO
CHECKED BY:

NOTE:
THE CONTRACTOR SHALL VERIFY EXISTING FIELD CONDITIONS PRIOR TO BIDDING.

USER NAME = \$USERS	DESIGNED -	REVISED -
PLOT SCALE = \$SCALES	DRAWN -	REVISED -
PLOT DATE = \$DATES	CHECKED -	REVISED -
	DATE -	REVISED -

**STATE OF ILLINOIS
DEPARTMENT OF TRANSPORTATION**

EXISTING LIGHTING PLANS
I-74 & MAIN ST. INTERCHANGE - GALESBURG

SCALE: SHEET OF SHEETS STA. TO STA.

F.A.I. RTE.	SECTION	COUNTY	TOTAL SHEETS	SHEET NO.
74	48(26VB)BY-BY-1JBRR	KNOX	69	55
CONTRACT NO. 68DB3				
ILLINOIS FED. AID PROJECT				

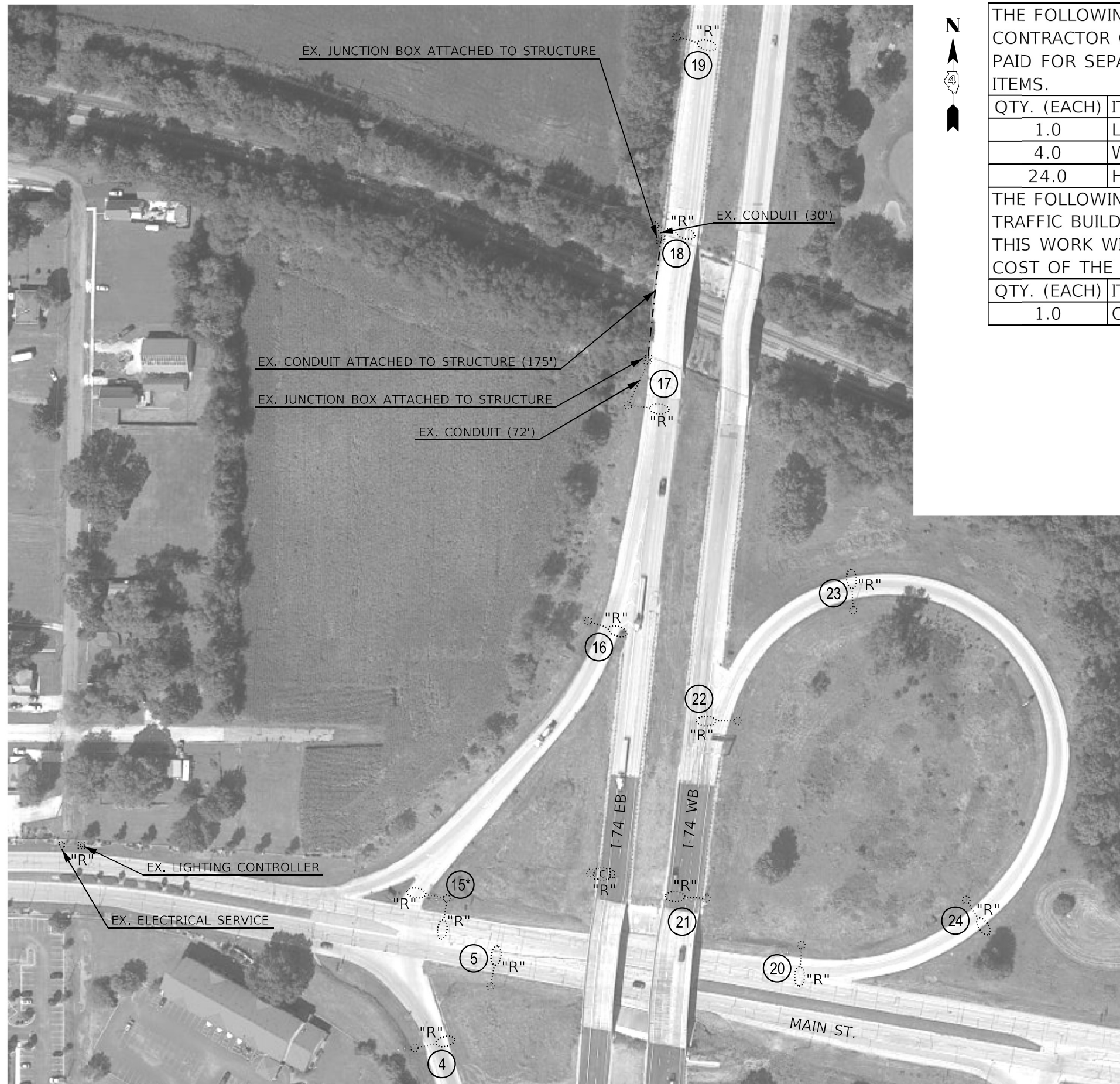

THE FOLLOWING ITEMS SHALL BE REMOVED AND DISPOSED OF BY THE CONTRACTOR OFF OF THE RIGHT-OF-WAY, THE COST OF THIS WORK WILL NOT BE PAID FOR SEPARATELY, BUT SHALL BE INCLUDED IN THE COST OF THE PROPOSED ITEMS.

QTY. (EACH)	ITEM
1.0	LIGHTING CONTROLLER CABINET (RE-USE EX. FOUNDATION)
4.0	WEATHERING STEEL LIGHT POLE (POLES 5, 6, 8, 15)
24.0	HPS LUMINAIRE

THE FOLLOWING ITEMS SHALL BE REMOVED AND DELIVERED TO THE IDOT TRAFFIC BUILDING AT 1025 W. DETWEILLER DR. PEORIA, IL 61615. THE COST OF THIS WORK WILL NOT BE PAID FOR SEPARATELY, BUT SHALL BE INCLUDED IN THE COST OF THE PROPOSED ITEMS.

QTY. (EACH)	ITEM
1.0	CCTV CAMERA

LEGEND

- EX. LIGHT POLE (TENON MOUNT) AND COUPLINGS ON EXISTING METAL FOUNDATION
- EX. LIGHT POLE (TWIN TENON MOUNT) AND COUPLINGS ON EXISTING METAL FOUNDATION
- EX. ELECTRIC SERVICE
- EX. LIGHTING CONTROLLER CABINET
- EX. JUNCTION BOX ATTACHED TO STRUCTURE
- EX. CONDUIT ATTACHED TO STRUCTURE
- EX. CONDUIT
- POLE IDENTIFICATION NUMBER
- INDICATES REMOVAL ITEM
- LIGHT POLE WITH 2 LUMINAIRES
- EX. CCTV CAMERA

USER NAME = \$USERS	DESIGNED -	REVISED -
	DRAWN -	REVISED -
PLOT SCALE = \$SCALES	CHECKED -	REVISED -
PLOT DATE = \$DATES	DATE -	REVISED -

**STATE OF ILLINOIS
DEPARTMENT OF TRANSPORTATION**







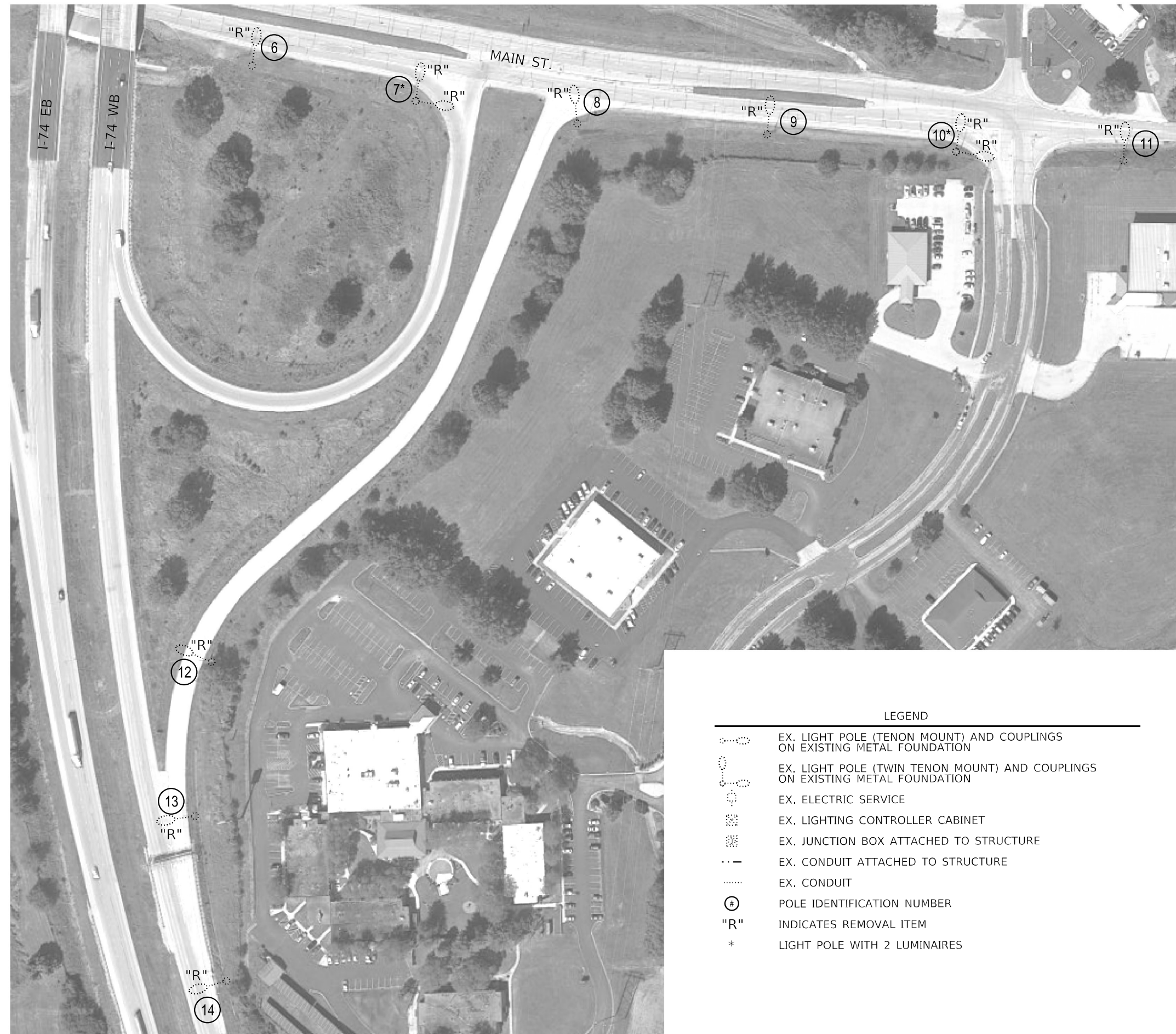



**PROPOSED LIGHTING REMOVAL PLANS
I-74 & MAIN ST. INTERCHANGE - GALESBURG**

SCALE: SHEET OF SHEETS STA. TO STA.

F.A.I. RTE.	SECTION	COUNTY	TOTAL SHEETS	SHEET NO.
74	48(126VB)BY.BY-11BRR	KNOX	69	56
				CONTRACT NO. 68D83
ILLINOIS FED. AID PROJECT				



LEGEND

-  EX. LIGHT POLE (TENON MOUNT) AND COUPLINGS ON EXISTING METAL FOUNDATION
-  EX. LIGHT POLE (TWIN TENON MOUNT) AND COUPLINGS ON EXISTING METAL FOUNDATION
-  EX. ELECTRIC SERVICE
-  EX. LIGHTING CONTROLLER CABINET
-  EX. JUNCTION BOX ATTACHED TO STRUCTURE
-  EX. CONDUIT ATTACHED TO STRUCTURE
-  EX. CONDUIT
-  POLE IDENTIFICATION NUMBER
-  INDICATES REMOVAL ITEM
-  LIGHT POLE WITH 2 LUMINAIRES

LIGHTING SHEET 4 OF 9

NOT TO SCALE

MODEL NUMBER NAME
FILE NAME: SHEETS

USER NAME = \$USERS	DESIGNED -	REVISED -
	DRAWN -	REVISED -
PLOT SCALE = \$SCALE\$	CHECKED -	REVISED -
PLOT DATE = \$DATE\$	DATE -	REVISED -

**STATE OF ILLINOIS
DEPARTMENT OF TRANSPORTATION**

**PROPOSED LIGHTING REMOVAL PLANS - CONTINUED
I-74 & MAIN ST. INTERCHANGE - GALESBURG**

SCALE: SHEET OF SHEETS STA. TO STA.

F.A.I. RTE.	SECTION	COUNTY	TOTAL SHEETS	SHEET NO.
74	48(126VB)BY.BY-11BRR	KNOX	69	57
			CONTRACT NO. 68D83	
ILLINOIS FED. AID PROJECT				

TOTAL BILL OF MATERIAL

I-74 & MAIN ST. INTERCHANGE - LIGHT POLE SCHEDULE

POLE NUMBER	VOLTAGE	EXISTING		PROPOSED					INSTALLATION NOTES	
		EX. POLE TYPE	LUMINAIRE TYPE	LIGHT POLE, GALVANIZED STEEL, 45 FT. M.H., TENON MOUNT (QTY.)	BREAKAWAY DEVICE, COUPLING WITH STAINLESS STEEL SCREEN	FURNISH AND INSTALL METAL SCREEN	LUMINAIRE, LED, ROADWAY, OUTPUT DESIGNATION H (QTY.)	LUMINAIRE MOUNTING BRACKET - SPECIAL (QTY.)		FOUNDATION
				EACH	EACH	EACH	EACH	EACH		
4	240V	WEATHERING STEEL	250W HPS			1.0	1.0	1.0	EX. METAL FOUNDATION	
5	240V	WEATHERING STEEL	250W HPS	1.0	4.0		1.0	1.0	EX. METAL FOUNDATION	
6	240V	WEATHERING STEEL	250W HPS	1.0	4.0		1.0	1.0	EX. METAL FOUNDATION	
7	240V	WEATHERING STEEL	250W HPS X 2			1.0	2.0	1.0	EX. METAL FOUNDATION	
8	240V	WEATHERING STEEL	250W HPS	1.0	4.0		2.0	1.0	EX. METAL FOUNDATION	
9	240V	WEATHERING STEEL	250W HPS			1.0	1.0	1.0	EX. METAL FOUNDATION	
10	240V	WEATHERING STEEL	250W HPS X 2			1.0	2.0	1.0	EX. METAL FOUNDATION	
11	240V	WEATHERING STEEL	250W HPS			1.0	1.0	1.0	EX. METAL FOUNDATION	
12	240V	WEATHERING STEEL	250W HPS			1.0	1.0	1.0	EX. METAL FOUNDATION	
13	240V	WEATHERING STEEL	250W HPS			1.0	1.0	1.0	EX. METAL FOUNDATION	
14	240V	WEATHERING STEEL	250W HPS			1.0	1.0	1.0	EX. METAL FOUNDATION	
15	240V	WEATHERING STEEL	250W HPS X 2	1.0	4.0		2.0	1.0	EX. METAL FOUNDATION	
16	240V	GALVANIZED STEEL	250W HPS			1.0	1.0	1.0	EX. METAL FOUNDATION	
17	240V	WEATHERING STEEL	250W HPS			1.0	1.0	1.0	EX. METAL FOUNDATION	
18	240V	WEATHERING STEEL	250W HPS				1.0	1.0	EX. METAL FOUNDATION	
19	240V	WEATHERING STEEL	250W HPS				1.0	1.0	EX. METAL FOUNDATION	
20	240V	WEATHERING STEEL	250W HPS			1.0	1.0	1.0	EX. METAL FOUNDATION	
21	240V	WEATHERING STEEL	250W HPS				1.0	1.0	EX. METAL FOUNDATION	
22	240V	WEATHERING STEEL	250W HPS			1.0	1.0	1.0	EX. METAL FOUNDATION	
23	240V	WEATHERING STEEL	250W HPS			1.0	1.0	1.0	EX. METAL FOUNDATION	
24	240V	GALVANIZED STEEL	250W HPS			1.0	1.0	1.0	EX. METAL FOUNDATION	
TOTAL				4.0	16.0	14.0	25.0	21.0		

FURNISH AND INSTALL NEW FUSEHOLDERS, FUSES, SURGE ARRESTORS, AND POLE WIRING FOR EACH PROPOSED LUMINAIRE IN ACCORDANCE WITH HIGHWAY STANDARD 821101-02. THIS WORK WILL BE INCLUDED IN THE COST OF THR PROPOSED LUMINAIRES.

MODEL NAME: ILM1M5
FILE NAME: ILM1M5.DWG

USER NAME = \$USERS	DESIGNED -	REVISED -
	DRAWN -	REVISED -
PLOT SCALE = \$SCALE\$	CHECKED -	REVISED -
PLOT DATE = \$DATE\$	DATE -	REVISED -

**STATE OF ILLINOIS
DEPARTMENT OF TRANSPORTATION**

**PROPOSED LIGHT POLE SCHEDULE
I-74 & MAIN ST. INTERCHANGE - GALESBURG**

SCALE: SHEET OF SHEETS STA. TO STA.

F.A.I. RTE.	SECTION	COUNTY	TOTAL SHEETS	SHEET NO.
74	48(126VB)BY.BY-11BRR	KNOX	69	58
CONTRACT NO. 68D83				
ILLINOIS FED. AID PROJECT				

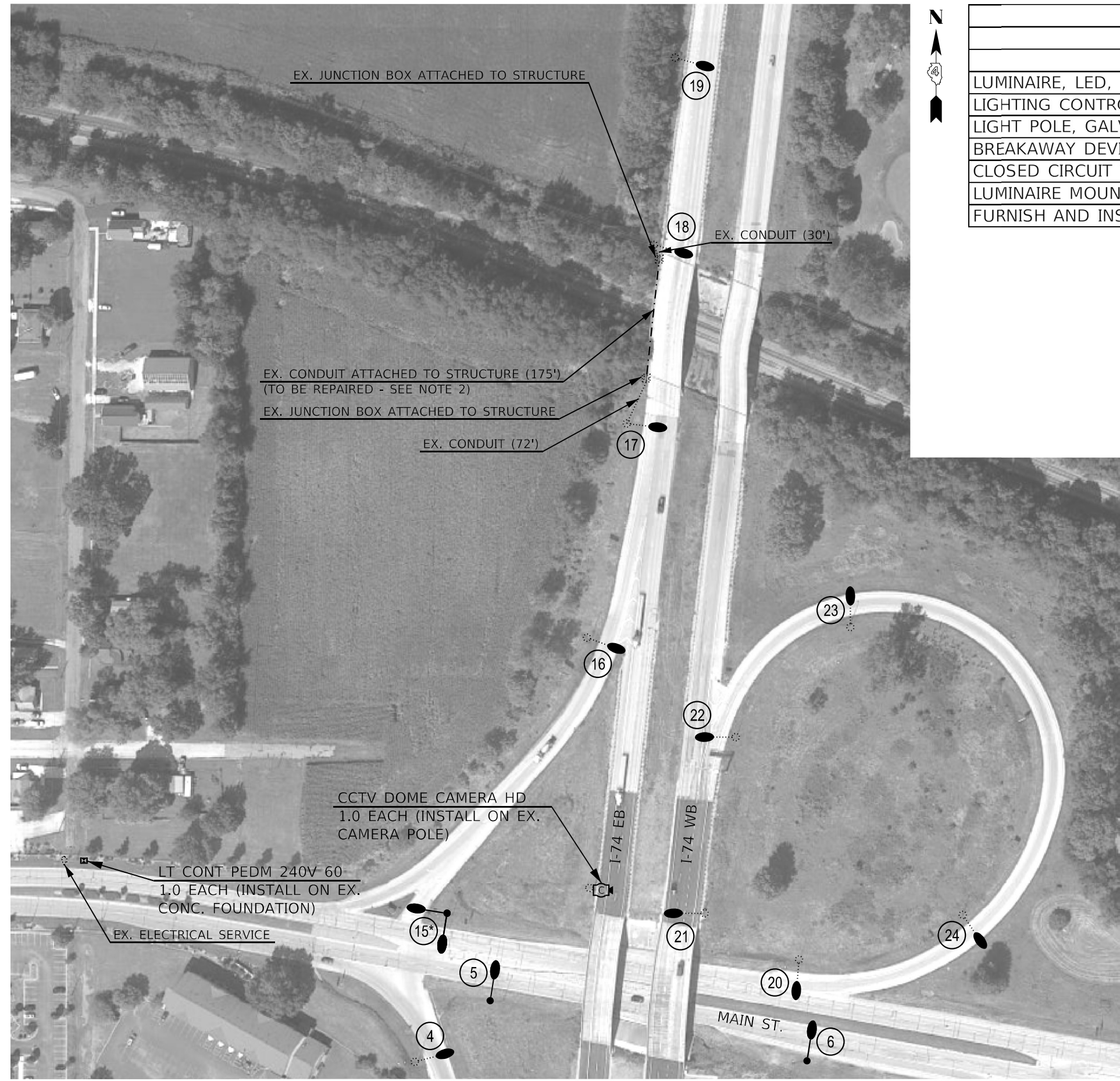

BILL OF MATERIALS		
I-74 & MAIN ST. INTERCHANGE (LIGHTING SHEET 5)		
ITEM DESCRIPTION	UNIT	QTY.
LUMINAIRE, LED, ROADWAY, OUTPUT DESIGNATION H	EACH	14.0
LIGHTING CONTROLLER, PEDESTAL MOUNTED, 240VOLT, 60AMP	EACH	1.0
LIGHT POLE, GALVANIZED STEEL, 45 FT. M.H., TENON MOUNT	EACH	3.0
BREAKAWAY DEVICE, COUPLING WITH STAINLESS STEEL SCREEN	EACH	12.0
CLOSED CIRCUIT TELEVISION DOME CAMERA, HD	EACH	1.0
LUMINAIRE MOUNTING BRACKET - SPECIAL	EACH	13.0
FURNISH AND INSTALL METAL SCREEN	EACH	7.0

NOTES:

1. THE CONTRACTOR SHALL FURNISH AND INSTALL THE CCTV DOME CAMERA ASSEMBLY, CAMERA BRACKET, AND ALL OTHER ITEMS REQUIRED FOR INSTALLATION AND OPERATION ON THE EXISTING CAMERA POLE, AS SHOWN IN THE PLANS. THE EXISTING CAT 5 CABLE WILL BE RE-USED. THIS WORK WILL NOT BE PAID FOR SEPARATELY, BUT SHALL BE INCLUDED IN THE BID PRICE FOR THE CLOSED CIRCUIT TELEVISION DOME CAMERA, HD.
2. THE CONTRACTOR SHALL MAKE MINOR REPAIRS TO THE EXISTING CONDUIT ATTACHED TO STRUCTURE AND ASSOCIATED FITTINGS AS NEEDED. THIS WORK WILL BE PAID FOR AS EXTRA WORK IN ACCORDANCE WITH ARTICLE 109.04 OF THE STANDARD SPECIFICATIONS.

LEGEND

- PROP. LIGHT POLE (GALVANIZED STEEL, TENON MOUNT), LUMINAIRE, LED, ROADWAY, OUTPUT DESIGNATION H (QTY. 1) AND COUPLINGS ON EXISTING METAL FOUNDATION
- PROP. LIGHT POLE (GALVANIZED STEEL, TENON MOUNT), LUMINAIRE, LED, ROADWAY, OUTPUT DESIGNATION H (QTY. 2) AND COUPLINGS ON EXISTING METAL FOUNDATION
- PROP. LUMINAIRE, LED, ROADWAY, OUTPUT DESIGNATION H (QTY. 1) ON EX. LIGHT POLE WITH PROP. METAL SCREEN
- PROP. LUMINAIRE, LED, ROADWAY, OUTPUT DESIGNATION H (QTY. 2) ON EX. LIGHT POLE WITH PROP. METAL SCREEN
- EX. ELECTRIC SERVICE
- PROP. LIGHTING CONTROLLER CABINET
- EX. JUNCTION BOX ATTACHED TO STRUCTURE
- EX. CONDUIT ATTACHED TO STRUCTURE (REPAIRED - SEE NOTE 2)
- EX. CONDUIT
- POLE IDENTIFICATION NUMBER
- LIGHT POLE WITH 2 LUMINAIRES
- PROP. CCTV DOME CAMERA HD

MODEL NUMBER: N/A
FILE NAME: SHEETS

USER NAME = \$USERS	DESIGNED -	REVISED -
PLOT SCALE = \$SCALES	DRAWN -	REVISED -
PLOT DATE = \$DATES	CHECKED -	REVISED -
	DATE -	REVISED -

**STATE OF ILLINOIS
DEPARTMENT OF TRANSPORTATION**





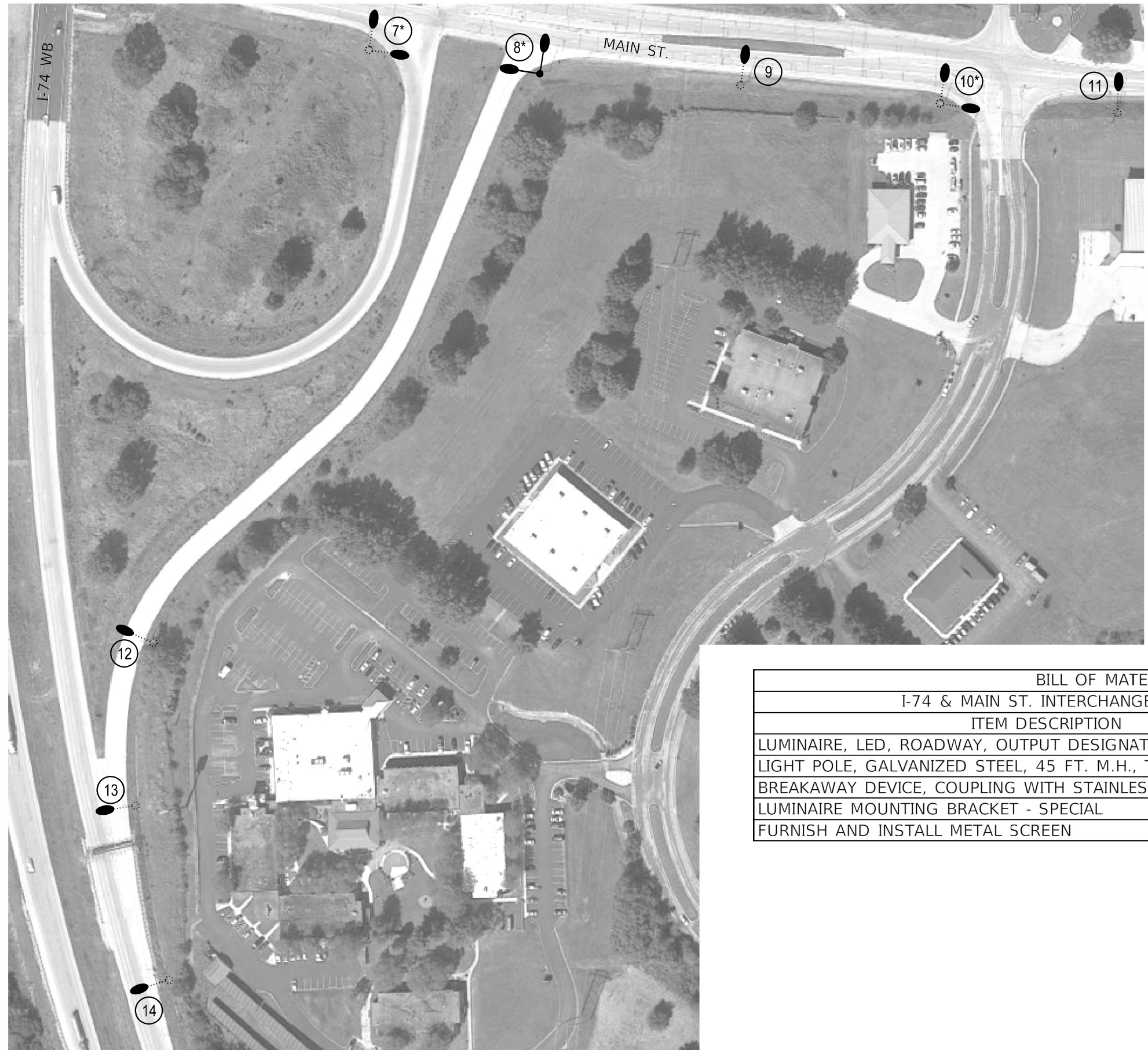

**PROPOSED LIGHTING PLANS
I-74 & MAIN ST. INTERCHANGE - GALESBURG**

F.A.I. RTE.	SECTION	COUNTY	TOTAL SHEETS	SHEET NO.
74	48(26VB)BY.BY-1JBRR	KNOX	69	59
CONTRACT NO. 68D83				
ILLINOIS FED. AID PROJECT				

SCALE: SHEET OF SHEETS STA. TO STA.



LEGEND

-  PROP. LIGHT POLE (GALVANIZED STEEL, TENON MOUNT), LUMINAIRE, LED, ROADWAY, OUTPUT DESIGNATION H (QTY. 1) AND COUPLINGS ON EXISTING METAL FOUNDATION
-  PROP. LIGHT POLE (GALVANIZED STEEL, TENON MOUNT) LUMINAIRE, LED, ROADWAY, OUTPUT DESIGNATION H (QTY. 2) AND COUPLINGS ON EXISTING METAL FOUNDATION
-  PROP. LUMINAIRE, LED, ROADWAY, OUTPUT DESIGNATION H (QTY. 1) ON EX. LIGHT POLE WITH PROP. METAL SCREEN
-  PROP. LUMINAIRE, LED, ROADWAY, OUTPUT DESIGNATION H (QTY. 2) ON EX. LIGHT POLE WITH PROP. METAL SCREEN
-  EX. CONDUIT
-  POLE IDENTIFICATION NUMBER
-  * LIGHT POLE WITH 2 LUMINAIRES

BILL OF MATERIALS		
I-74 & MAIN ST. INTERCHANGE (LIGHTING SHEET 6)		
ITEM DESCRIPTION	UNIT	QTY.
LUMINAIRE, LED, ROADWAY, OUTPUT DESIGNATION H	EACH	11.0
LIGHT POLE, GALVANIZED STEEL, 45 FT. M.H., TENON MOUNT	EACH	1.0
BREAKAWAY DEVICE, COUPLING WITH STAINLESS STEEL SCREEN	EACH	4.0
LUMINAIRE MOUNTING BRACKET - SPECIAL	EACH	8.0
FURNISH AND INSTALL METAL SCREEN	EACH	7.0

LIGHTING SHEET 7 OF 9

NOT TO SCALE

MODEL NUMBER NAME
FILE NAME: SHEETS

USER NAME = \$USERS	DESIGNED -	REVISED -
	DRAWN -	REVISED -
PLOT SCALE = \$SCALE\$	CHECKED -	REVISED -
PLOT DATE = \$DATE\$	DATE -	REVISED -

**STATE OF ILLINOIS
DEPARTMENT OF TRANSPORTATION**

PROPOSED LIGHTING PLANS - CONTINUED
I-74 & MAIN ST. INTERCHANGE - GALESBURG

SCALE: SHEET OF SHEETS STA. TO STA.

F.A.I. RTE.	SECTION	COUNTY	TOTAL SHEETS	SHEET NO.
74	48(26VB)BY.BY-11BRR	KNOX	69	60
CONTRACT NO. 68D83				
ILLINOIS FED. AID PROJECT				

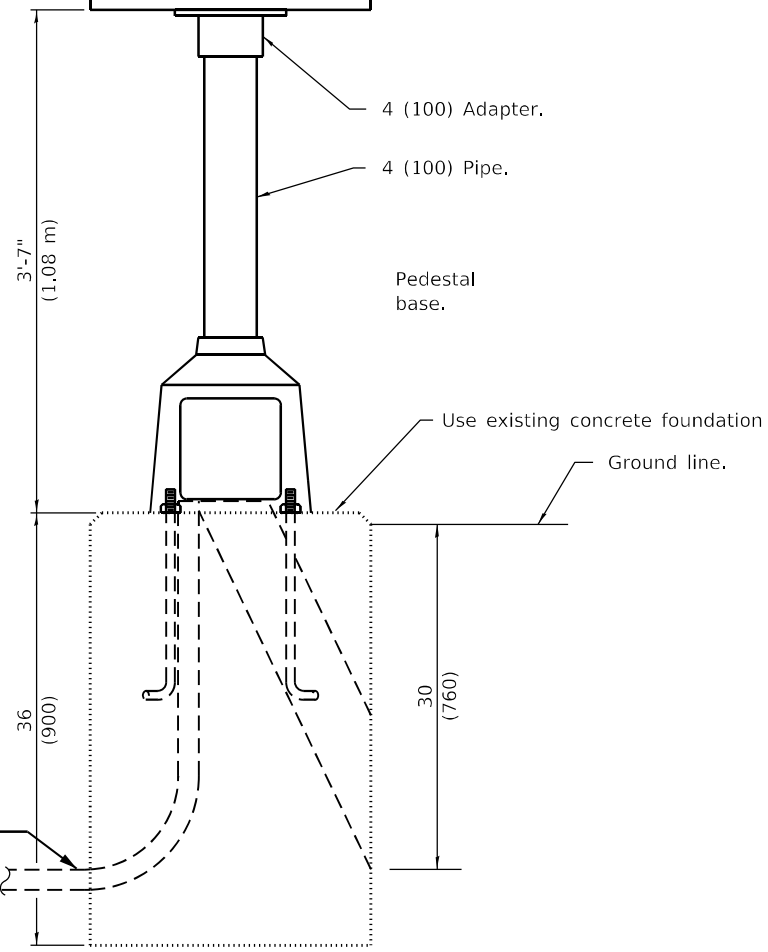
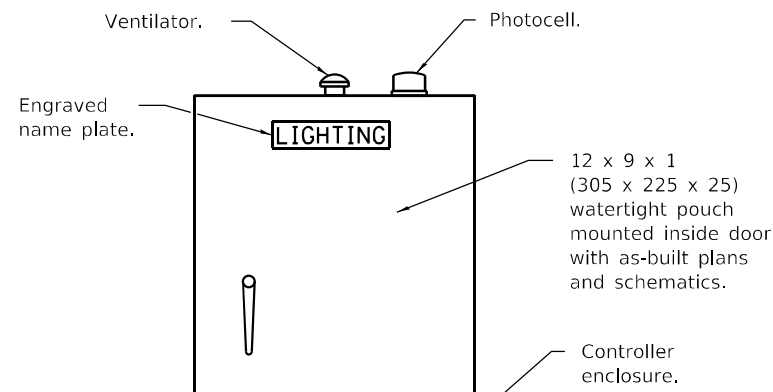

LIGHTING CONTROLLER

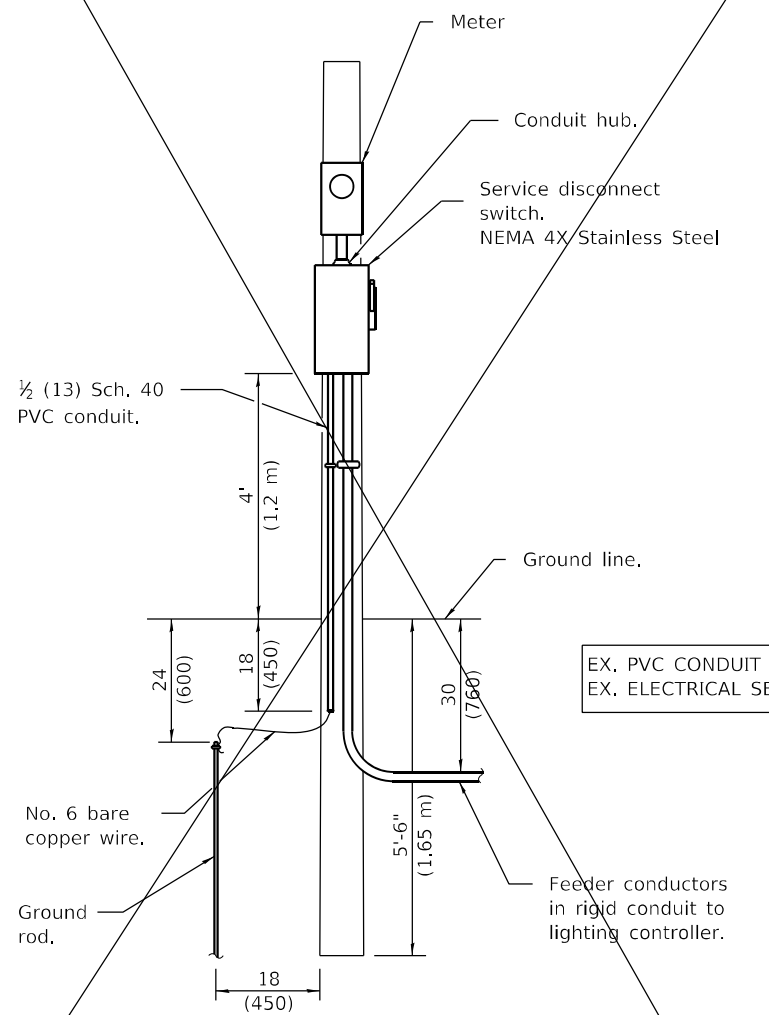

ELECTRIC SERVICE INSTALLATION

(Typical overhead service shown. Cut pole off for underground service and treat cut surface with preservative. Consult utility company standards for exact requirements.)
* Size larger as needed.

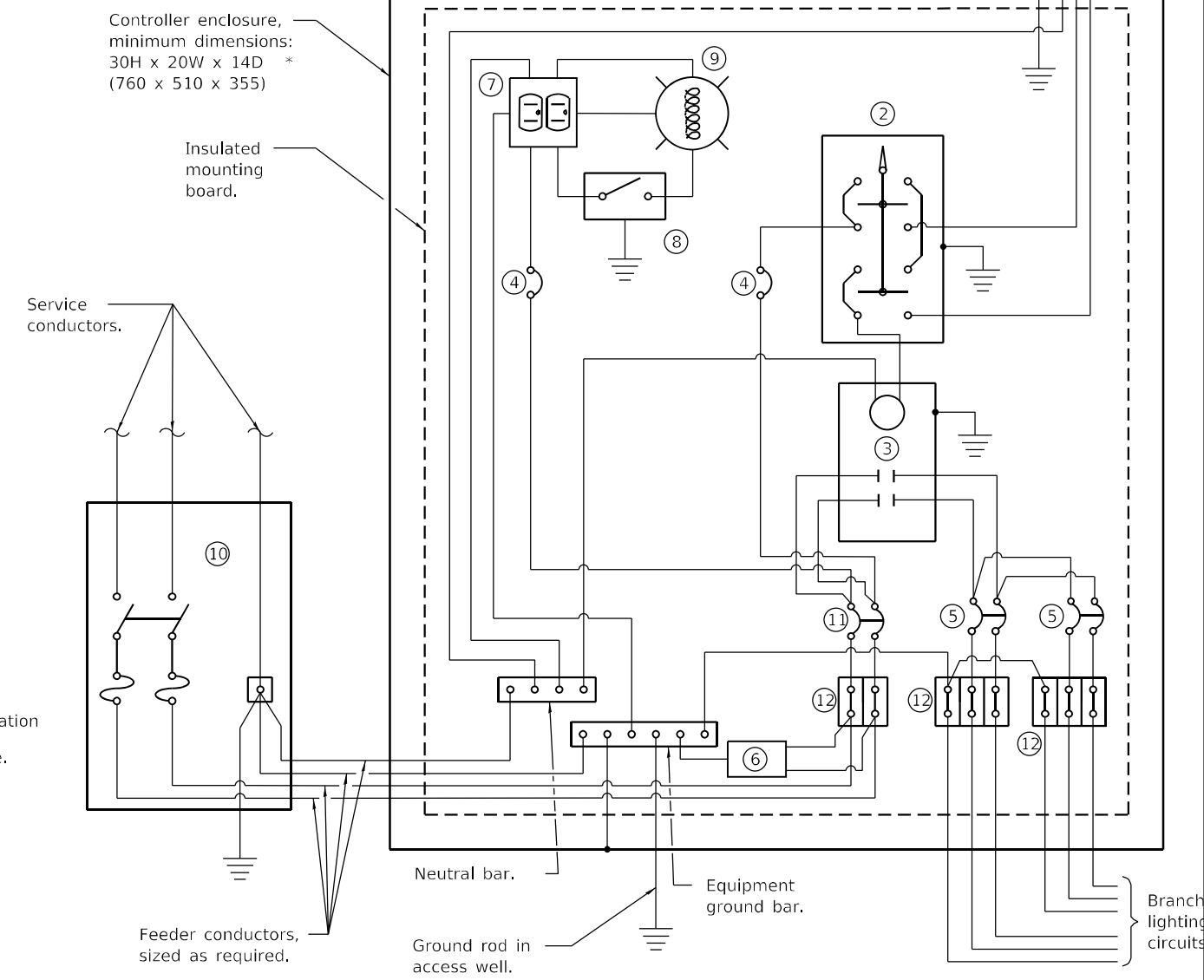

CONTROL SCHEMATIC

- ① Photocell with integral surge arrester.
 - ② HAND-OFF-AUTO selector switch.
 - ③ 60 amp*, electrically held contactor.
 - ④ 15 amp, 1-pole circuit breaker. (TO ITS CABINET)
 - ⑤ 30 amp*, 2-pole circuit breaker (QTY 2.0 PLUS 2 SPARE).
 - ⑥ Surge arrester.
 - ⑦ GFCI duplex receptacle.
 - ⑧ Single-pole, single-throw switch.
 - ⑨ LED light bulb, enclosed and gasketed with 800 lumen lamp.
 - ⑩ Service disconnect switch - 2-pole, 3-wire, 60 amp*, fused at 60 amp*, solid neutral in NEMA 4X enclosure having lockable external handle.
 - ⑪ 60 amp*, 2-pole circuit breaker.
 - ⑫ Terminal block sized for conductors as shown on plans.
- * Size larger as needed.

All dimensions are in inches (millimeters) unless otherwise shown.

MODEL NUMBER/NAME FILE NAME SHEETS

USER NAME = \$USERS	DESIGNED -	REVISED -
DRAWN -	REVISIONS -	
PLOT SCALE = \$SCALES	CHECKED -	REVISIONS -
PLOT DATE = \$DATES	DATE -	REVISIONS -

**STATE OF ILLINOIS
DEPARTMENT OF TRANSPORTATION**

PROPOSED LIGHTING CONTROLLER DETAIL

SCALE: SHEET OF SHEETS STA. TO STA.

F.A.I. RTE.	SECTION	COUNTY	TOTAL SHEETS	SHEET NO.
74	48(26VB)BY-BY-1JBRR	KNOX	69	61
CONTRACT NO. 68DB3				
ILLINOIS FED. AID PROJECT				

LUMINAIRE, LED, ROADWAY, OUTPUT DESIGNATION H

Project

Date	Contract Number	Section Number	County
08-21-2023	68D83		KNOX
Marked Route Number		Municipality	

Roadway

Lane Width	# of Lanes	Median Width	I.E.S Surface Classification	O-Zero Value
12 ft	3	N/A	R3	0.07

Structure

Mounting Height	Arm Length	Set Back	Number of Luminaires (Highmast & Sign Lighting Only)
45 ft	2 ft	18 ft	N/A

Luminaire

Description	I.E.S. Transverse Distribution	I.E.S. Lateral Distribution	
LUMINAIRE, LED, ROADWAY, OUTPUT DESIGNATION H	TYPE III	SHORT/MEDIUM	
Total Light Loss Factor (LLF)	BUG Rating	Shields	Dimming Protocol
0.7	U = 0	N/A	0-10V

Layout

Spacing (to Nearest 5 Ft)	Configuration (Opposite, Staggered, 1 Sided, or Median)
220 ft	SINGLE SIDED

Performance

Average Illuminance, E_{AVE} (fc)	Uniformity Ratio, E_{AVE}/E_{MIN}		
≥ 0.8	$\leq 3.0:1$		
Average Luminance, L_{AVE} (cd/m ²)	Uniformity Ratio, L_{AVE}/L_{MIN}	Uniformity Ratio, L_{MAX}/L_{MIN}	Veiling Luminance Ratio, L_v/L_{MIN}
≥ 0.5	$\leq 3.0:1$	$\leq 5.0:1$	≤ 0.3

Light Trespass

Distance to ROW (behind pole)	Max. Horizontal Illuminance at ROW, E_H	Max. Vertical Illuminance at ROW, E_V
N/A	N/A	N/A

Notes

1. Set Back is from Edge of Pavement (white line) except for sign luminaires when it is vertical and horizontal distance from the sign to the luminaire.
2. Lighting calculations shall be performed with all luminaires oriented toward and perpendicular to roadway.
3. Total Light Loss Factor (LLF) = the product of "Lumen Maintenance" (LLD) = 0.9, "Dirt Depreciation" (LDD) = 0.8, and "Equipment Factors" (EF) = 0.95.
4. Performance requirements shall be the minimum acceptable standards of photometric performance for the luminaire, based on the given conditions above.
5. Lighting calculations shall be performed in one direction only.
6. Compliance with performance criteria shall be held to one significant digit.

USER NAME = \$USERS	DESIGNED -	REVISED -	
	DRAWN -	REVISED -	
PLOT SCALE = \$SCALE\$	CHECKED -	REVISED -	
PLOT DATE = \$DATE\$	DATE -	REVISED -	

F.A.I. RTE.	SECTION	COUNTY	TOTAL SHEETS	SHEET NO.
74	48[(26VB)BY-BY-1]BRR	KNOX	69	62
CONTRACT NO. 68D83				
ILLINOIS FED. AID PROJECT				

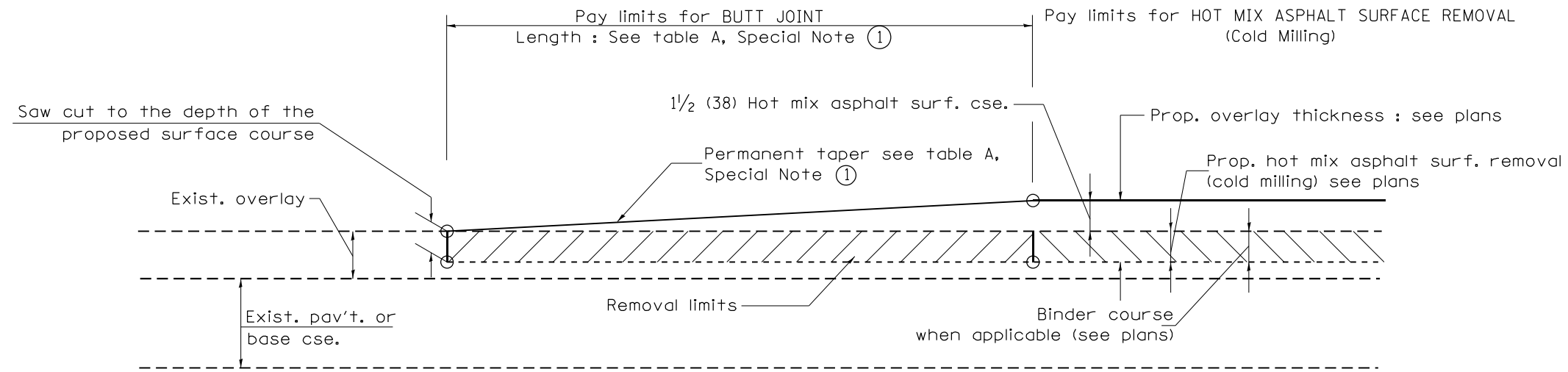

CASE 1 : WITH HOT MIX ASPHALT SURFACE REMOVAL (COLD MILLING)

**TABLE A
TAPER RATES**

SPECIAL NOTE NUMBER	ELEMENT	MAINLINE INTERSTATES & 4-LANE EXPRESSWAYS	ALL OTHERS
①	BUTT JOINT TAPER RATE	1:480	1:240
②	TEMPORARY RAMP TAPER RATE	1:80	1:40

GENERAL NOTES

1. The work shall be done in accordance with Article 406.08 and the Special Provision for Butt Joints.
2. The pavement surface to be removed may be either bituminous or P.C. concrete. The work shall be performed in accordance with Article 440.04 and the Special Provisions for Butt Joints.
3. The saw cut joints shall be primed just prior to the placing of bituminous material. The work will be in accordance with the applicable portions of Article 406.05.
4. The length of butt joint is based on the taper rate times change in cold milling depth within the butt joint pay limits, unless otherwise indicated.
5. Temporary ramps are paid for separately and not included in the cost of the butt joints.

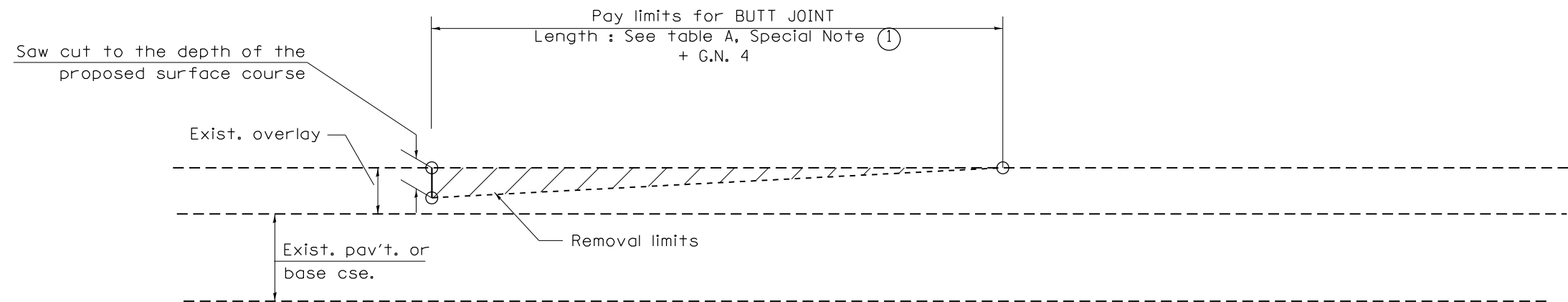

CASE 2 : NO HOT MIX ASPHALT SURFACE REMOVAL (COLD MILLING)

All dimensions are in inches (millimeters) unless otherwise noted.

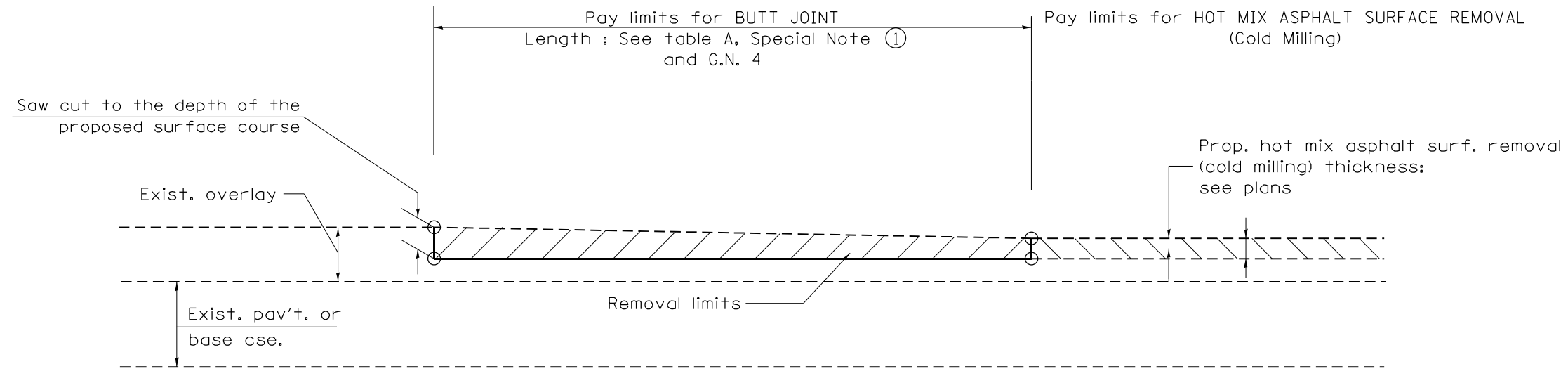

**CASE 3 : HOT MIX ASPHALT SURFACE REMOVAL (COLD MILLING)
TIE-IN TO EXISTING BITUMINOUS TAPER**

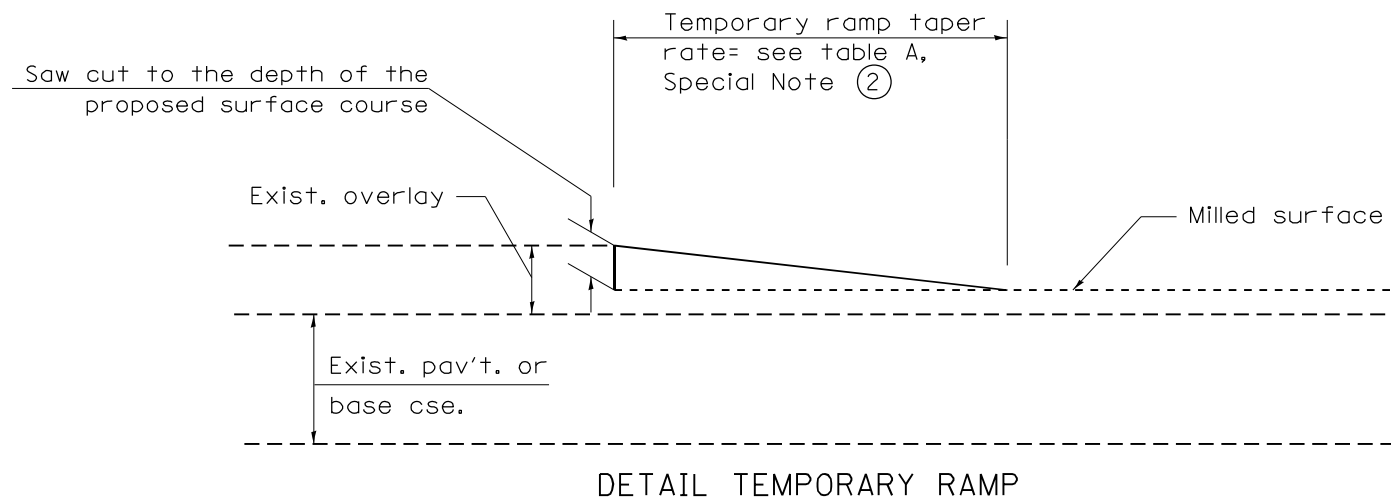

All dimensions are in inches (millimeters) unless otherwise noted.

STATE OF ILLINOIS DEPARTMENT OF TRANSPORTATION				BUTT JOINTS				SHT. 2 OF 3	
								CADD STD. 406101-D4	
F.A.I. RTE.	SECTION	COUNTY	TOTAL SHEETS	SHEET NO.	FED. ROAD DIST. NO. ILLINOIS FED. AID PROJECT				
74	48[(26VB)BY,BY-1]BRR	KNOX	69	64					

NOT TO SCALE

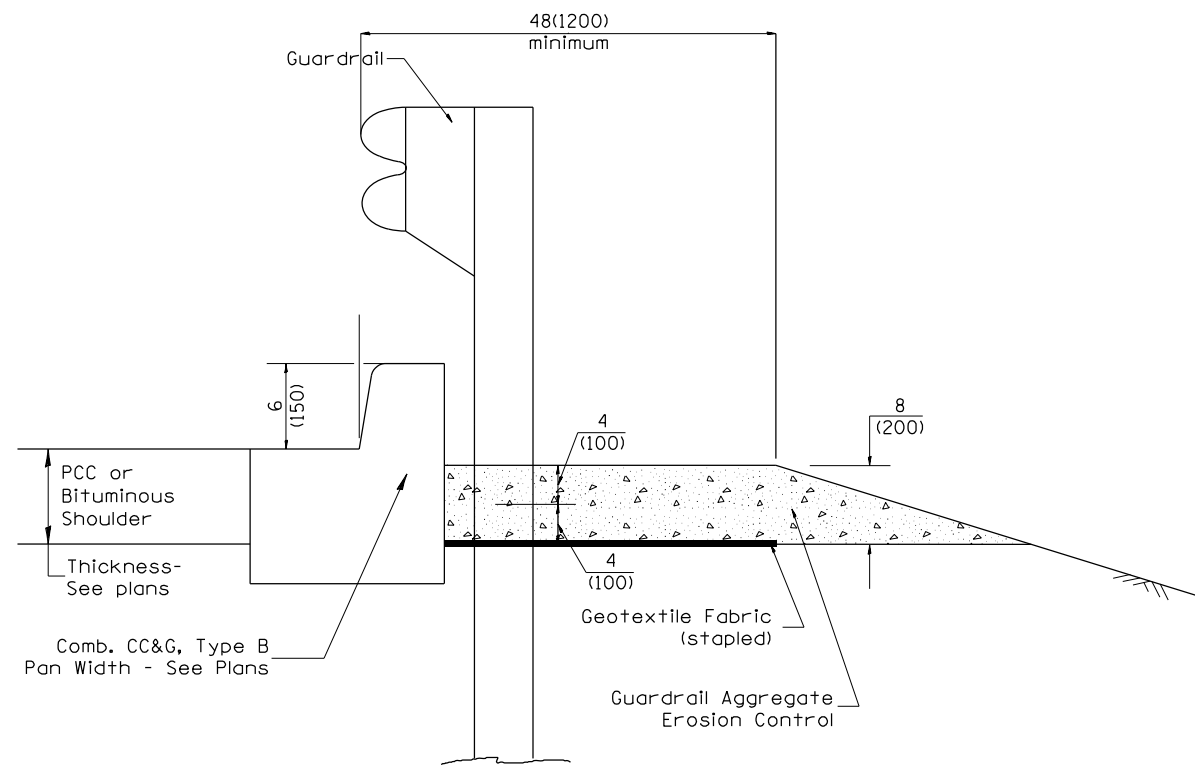

TYPICAL SECTION WITH COMBINATION CONCRETE CURB & GUTTER

GENERAL NOTES: GUARDRAIL AGGREGATE EROSION CONTROL

1. This work shall consist of grading as needed, furnishing and installing geotextile fabric and staples, and furnishing, placing and shaping crushed aggregate around and behind Steel Plate Beam Guardrail posts in accordance with Plan Details.
2. Before placing the aggregate and the Geotextile Fabric, weeds and grass shall be removed from the area to be covered.
3. After the area has been prepared, and in a dry condition, the Geotextile fabric shall be placed with a 12(300) minimum overlap. A knife cut for guardrail post installation is necessary.
4. The aggregate shall be deposited, compacted and shaped by either mechanical or hand methods, in a manner reasonably true to line and grade.
5. The Contractor shall have the option of placing the guardrail before or after the Geotextile Fabric and Aggregate are in place. If the guardrail is placed after the Geotextile Fabric and Aggregate, then any voids must be filled and the aggregate returned to line and grade.
6. Materials shall meet the following requirements:
 - A. The crushed aggregate shall be CA1 gradation in accordance with Article 1004.01(c) of the Standard Specifications.
 - B. The Geotextile Fabric shall be nonwoven fabric in accordance with Article 1080.02 of the Standard Specifications.

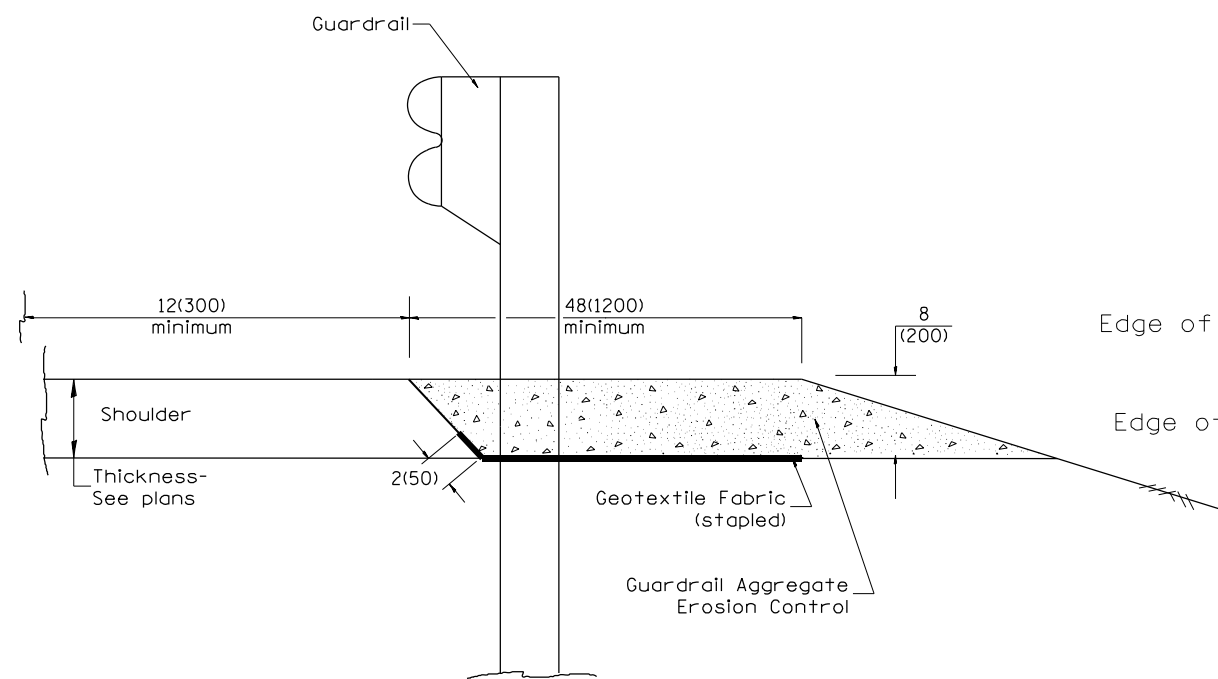

TYPICAL SECTION WITHOUT EROSION CONTROL CURB

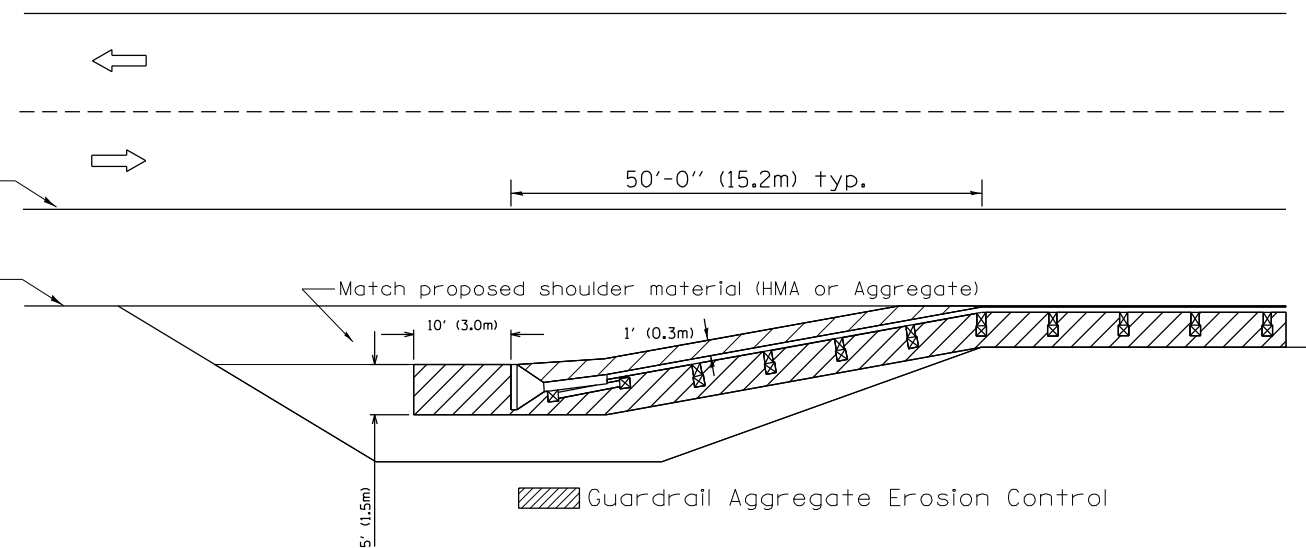

All dimensions are in inches (millimeters) unless otherwise noted.

03-07-11	ADDED DETAIL SHOWING PLAN VIEW	R.D.	5-30-18	CHANGE B CURB TO CC&G	R.D.
08-10-12	REVISED CURB "B" AND AGGREGATE	R.D.	07-16-19	SPELLING CORRECTIONS	R.D.
07-15-15	ADDRESSED SHOULDER INLET CURB	R.D.			
01-26-17	REVISED	R.D.			

**STATE OF ILLINOIS
DEPARTMENT OF TRANSPORTATION**

NOT TO SCALE

GUARDRAIL EROSION CONTROL TREATMENTS

SHT. 1 OF 2
CADD STD. 630101-D4

F.A.I. RTE.	SECTION	COUNTY	TOTAL SHEETS	SHEET NO.
74	48[26VB)BY,BY-1]BRR	KNOX	69	66
FED. ROAD DIST. NO. ILLINOIS FED. AID PROJECT			CONTRACT NO. 68D83	

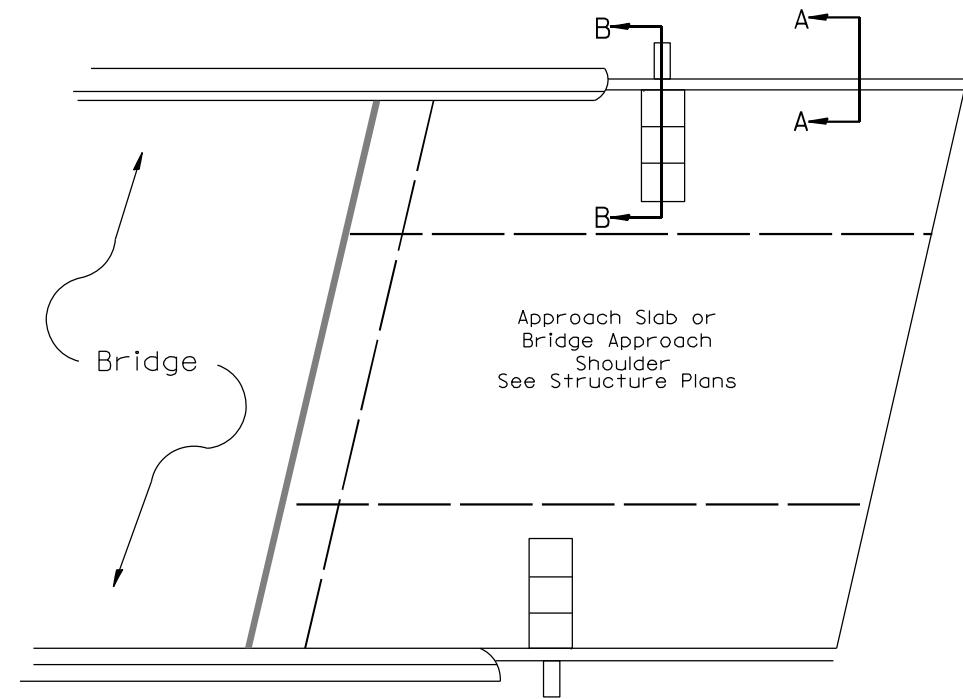
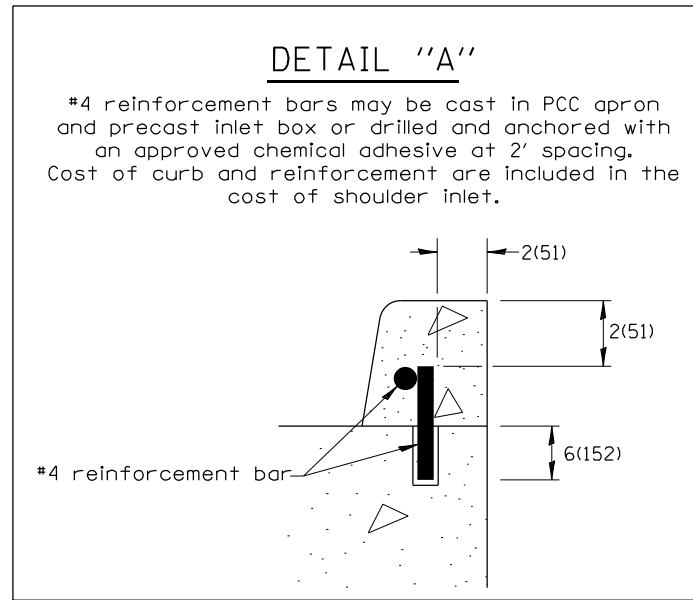

PLAN VIEW
APPROACH SLAB OR SHOULDER PLACEMENT

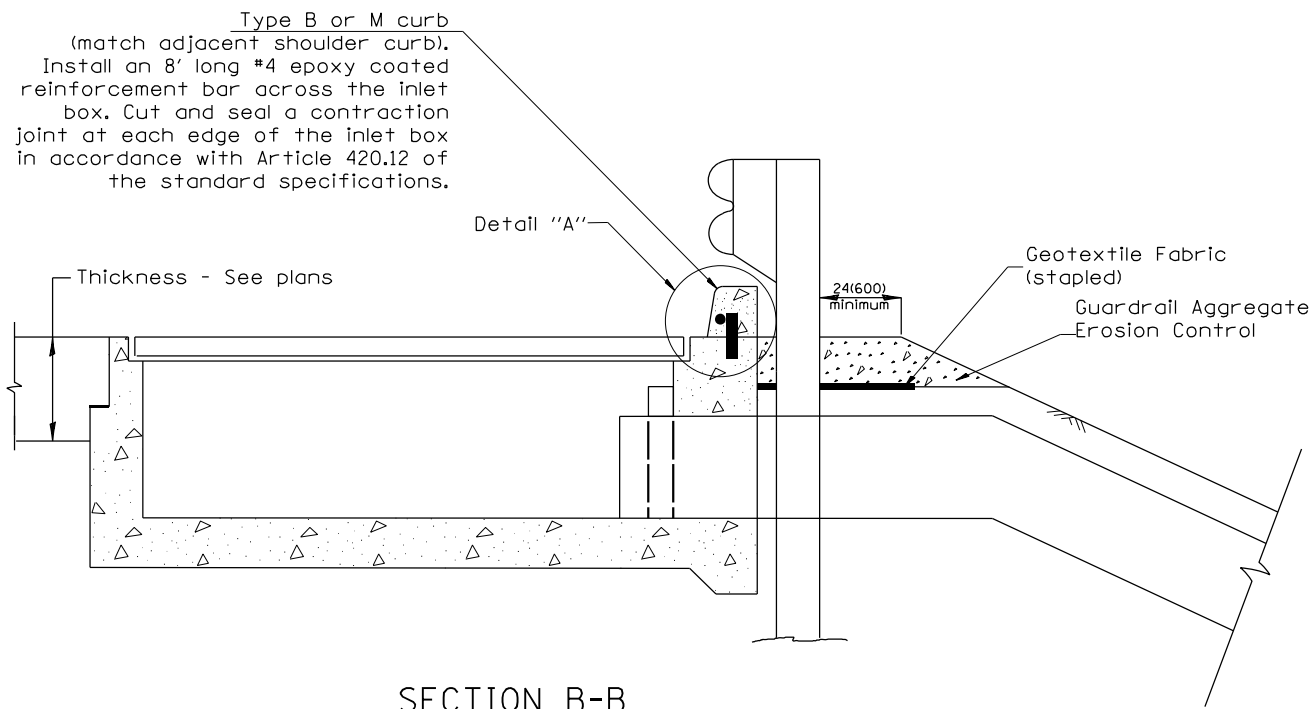

SECTION B-B
TYPICAL SECTION AT INLETS
TYPE E, F & G (HIGHWAY STANDARD 610001)

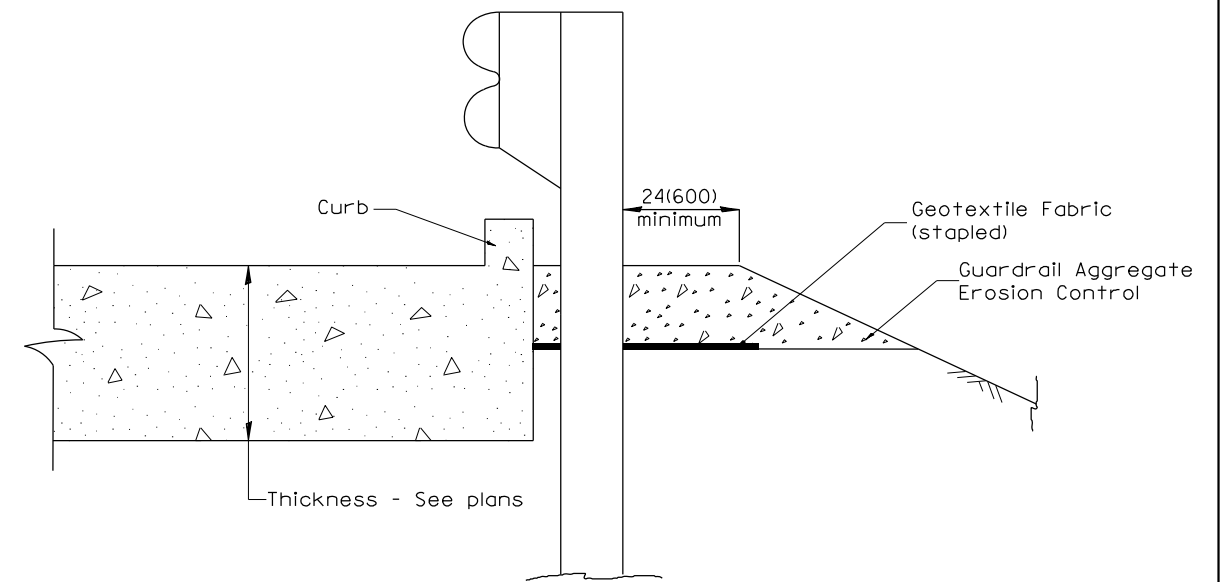

SECTION A-A
TYPICAL SECTION WITH BRIDGE APPROACH CURB

All dimensions are in inches (millimeters) unless otherwise noted.

STATE OF ILLINOIS				GUARDRAIL EROSION CONTROL TREATMENTS				TOTAL SHEETS	SHEET NO.
DEPARTMENT OF TRANSPORTATION				NOT TO SCALE				74	69
				SHT. 2 OF 2				CONTRACT NO. 68D83	
				CADD STD. 630101-D4				ILLINOIS FED. AID PROJECT	

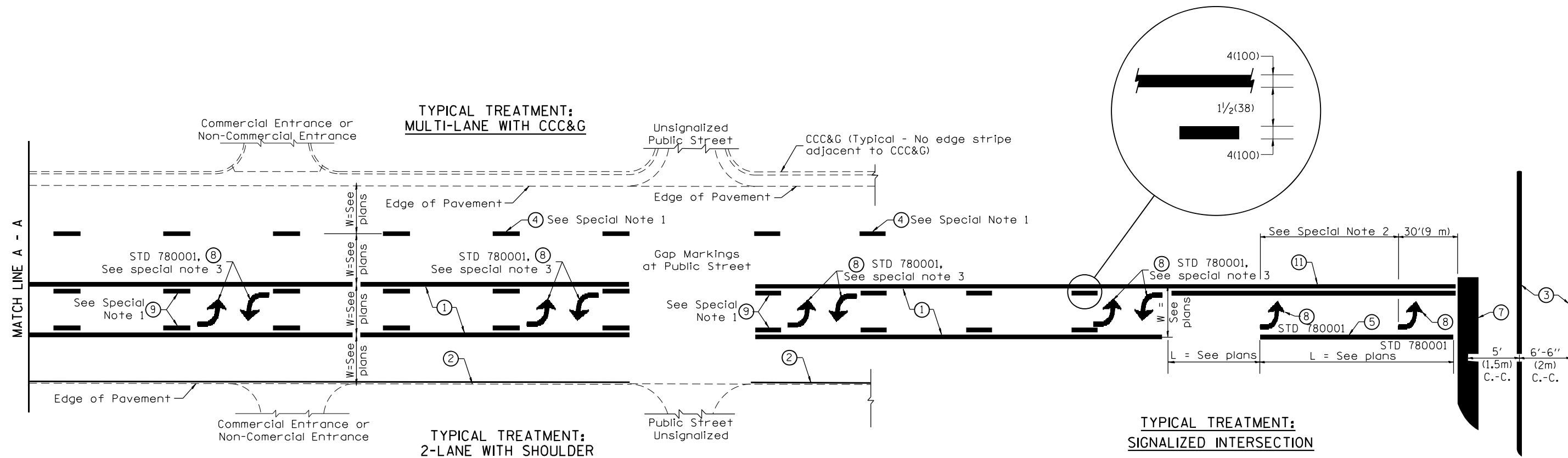

FLUSH PAVED MEDIAN: TWO-WAY LEFT TURN LANE WITH ONE-WAY LEFT TURN LANE AT SIGNALIZED INTERSECTION

TYPICAL PAVEMENT MARKING LEGEND

(Note: This is a District Standard Legend. Some elements may not apply to specific project.)

- ① 4(100) Solid (Yellow)
- ② 4(100) Solid (White)
- ③ 2-6(150) Crosswalk @ 6'-6" (2m)min C.-C. (White)
2-8(200) Crosswalk @ 6'-6" (2m)min C.-C. (White) (When traffic signals are present.)
- ④ 6(150) Skip-Dash (White) (See Special Note 1)
- ⑤ 8(200) Solid (White)
- ⑥ 12(300) Diagonal (White) (Item ⑥ is shown on Std. 780001)
- ⑦ 24(600) Stop Bar (White)
- ⑧ Letters & Arrows (See Std. 780001 and Special Notes 2 & 3)
- ⑨ 4(100) Skip-Dash (Yellow) (See Special Note 1)
- ⑩ 12(300) Diagonal (Yellow) (See Table A) ⑩
- ⑪ 4(100) Double Solid (Yellow) ⑪

SPECIAL NOTES

1. Skip-Dash markings will be centered between both ends of city blocks and shall be placed in alignment transversely across the pavement.
2. The following shall apply to arrows located in one-way left turn lanes:
 - A. A minimum of two (2) arrows is required.
 - B. The maximum spacing between arrows is 80' (24 m).
 - C. Arrows shall be evenly spaced if three (3) or more are required.
3. The following shall apply to arrow pairs located in two-way left turn lanes:
 - A. A minimum of two (2) arrow pairs is required.
 - B. The maximum spacing between arrow pairs is 200' (61 m).
 - C. Arrow pairs shall be evenly spaced if three (3) or more are required.
 - D. The spacing between Bi Directional Left Turn Arrows is 33' (10 m).

GENERAL NOTES

1. Refer to State Standard 780001 for additional Pavement Markings including letters & arrows.
2. See Plans for Pavement Markings adjacent to curbed islands and medians, and through lane reductions.
3. Refer to Article 780.13 for letter, number and symbol areas (sq. ft.)
4. Areas are grooved 1" beyond each edge for the following symbols:
Through Arrow= 14.8 sq. ft.
Large Left or Right Arrow= 21.9 sq. ft.
2 Arrow Combination Left (or Right) and Through= 34.9 sq. ft.
Wrong Way Arrow= 29.5 sq. ft.
Railroad Crossing Symbol= 69.8 sq. ft.
(For further information, refer to BDE Special Provision: Grooving for Recessed Pavement Markings)

01-01-97	RENUM. F-8.03, NEW REVISION BOX	T.P.	10-16-06	REVISED TO 2007 SPEC.	
02-07-97	ADD BI DIRECTIONAL DIMENSION	J.A.	2/29/16	ADDED GROOVING AREAS	R.D.
10-97	CORRECT BI DIRECTIONAL DIMENSION	J.A.	07-16-19	SPELLING CORRECTIONS	R.D.
08-02	ADD CROSSWALK DMNS. WITH T.S.	M.A.			

**STATE OF ILLINOIS
DEPARTMENT OF TRANSPORTATION**

NOT TO SCALE

TYPICAL PAVEMENT MARKINGS

SHT. 1 OF 2
CADD STD. 780001-D4

F.A.I. RTE.	SECTION	COUNTY	TOTAL SHEETS	SHEET NO.
74	48(26VB)BY,BY-1)BRR	KNOX	69	68
FED. ROAD DIST. NO. ILLINOIS FED. AID PROJECT			CONTRACT NO. 68D83	

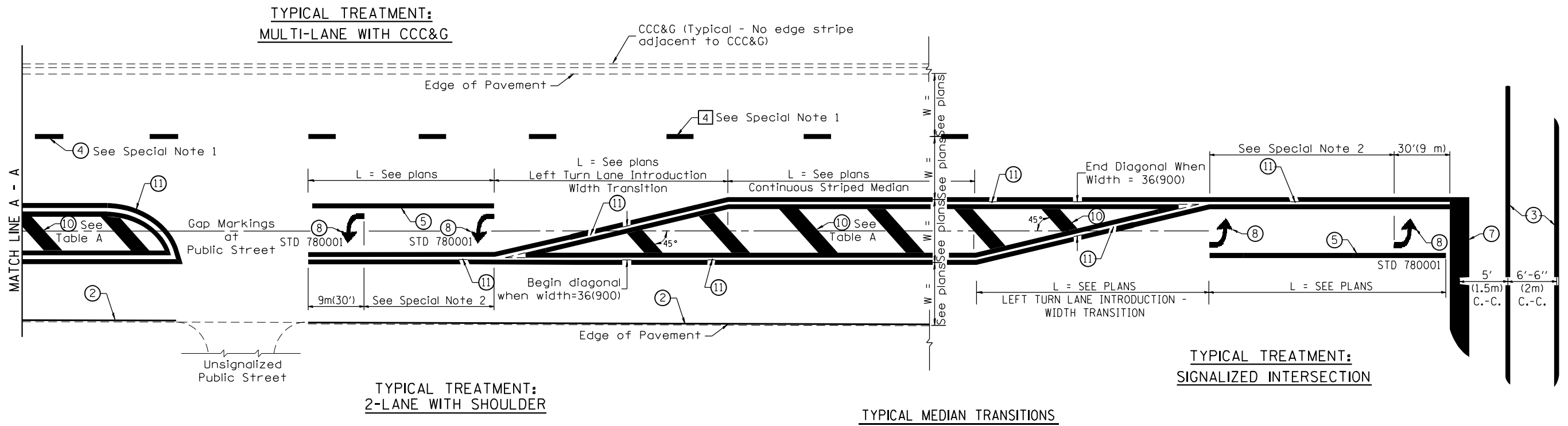

FLUSH PAVED MEDIAN: RESTRICTED LEFT TURN LANE

TABLE A
RECOMMENDED SPACING BETWEEN DIAGONAL LINES

SPEED LIMIT RANGE	INTERSECTION CHANNELIZATION (Includes Width Transitions for Median and Left Turn Lane Introductions)	
	CONTINUOUS	
Less Than 30 mph (50 km/h)	50' (15m)	15' (5m)
30 - 45 mph (50 - 70 km/h)	75' (23m)	20' (6m)
Over 45 mph (70 km/h)	150' (46m)	30' (9m)

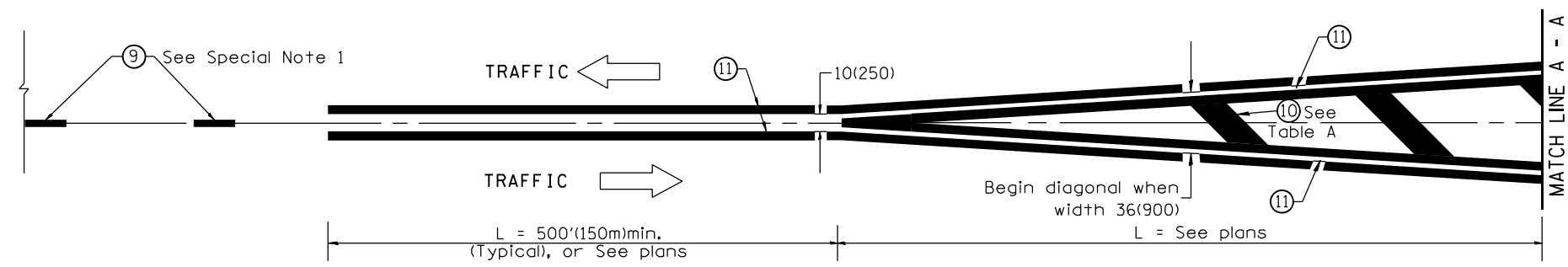

MEDIAN INTRODUCTION - WIDTH TRANSITIONS

All dimensions are in inches (millimeters) unless otherwise noted.